



Kawasaki Engine Conversion Kit

Suzuki-Powered Heavy-Duty Lawn Mowers with BBC

Model No. 119-7845

Installation Instructions

Installation

Loose Parts

Use the chart below to verify that all parts have been shipped.

Procedure	Description	Qty.	Use
2	Belt cover (74-1770)	1	Install the new engine.
	Engine (117-5220)	1	
	Decal (110-0520)	1	
	Screw (95-1727)	4	
	Blade retainer spacer (103-3795)	1	
	Tank bracket (115-0954-03)	1	
	Fuel tank cap (93-7198)	1	
	Screw (104-2628)	3	
	Fuel hose (109-0296)	1	
	Fuel filter (71-9280)	1	
	Clamp (2412-98)	4	
	Fuel hose (109-0650)	1	
	Cable tie (3290-378)	4	
	Blade bolt	1	
	BBC spacer	1	
Spring washer	2		
Throttle control (117-3543)	1		

1

Removing the Old Engine

No Parts Required

Procedure

Important: Save all fasteners that you removed for reuse unless otherwise noted.

1. Drain the fuel from the fuel tank.
2. Remove the old belt cover and discard it.
3. Remove and discard the throttle control cable.
4. Remove and discard the old fuel hose, fuel filter, and clamp.
5. Remove the blade and the BBC assembly.
6. Remove the belt from the driver pulley; inspect the belt for wear and replace it if necessary.

7. Remove the engine mounting bolts.
8. Remove the old engine from the mower housing.
9. Remove the fuel tank from the tank base and retain it for reuse.
10. Replace the fuel tank cap with a new cap provided in the kit; discard the old fuel tank cap.
11. Remove and discard the discharge tunnel door.
12. Clean the mower housing and check it for damage and wear.

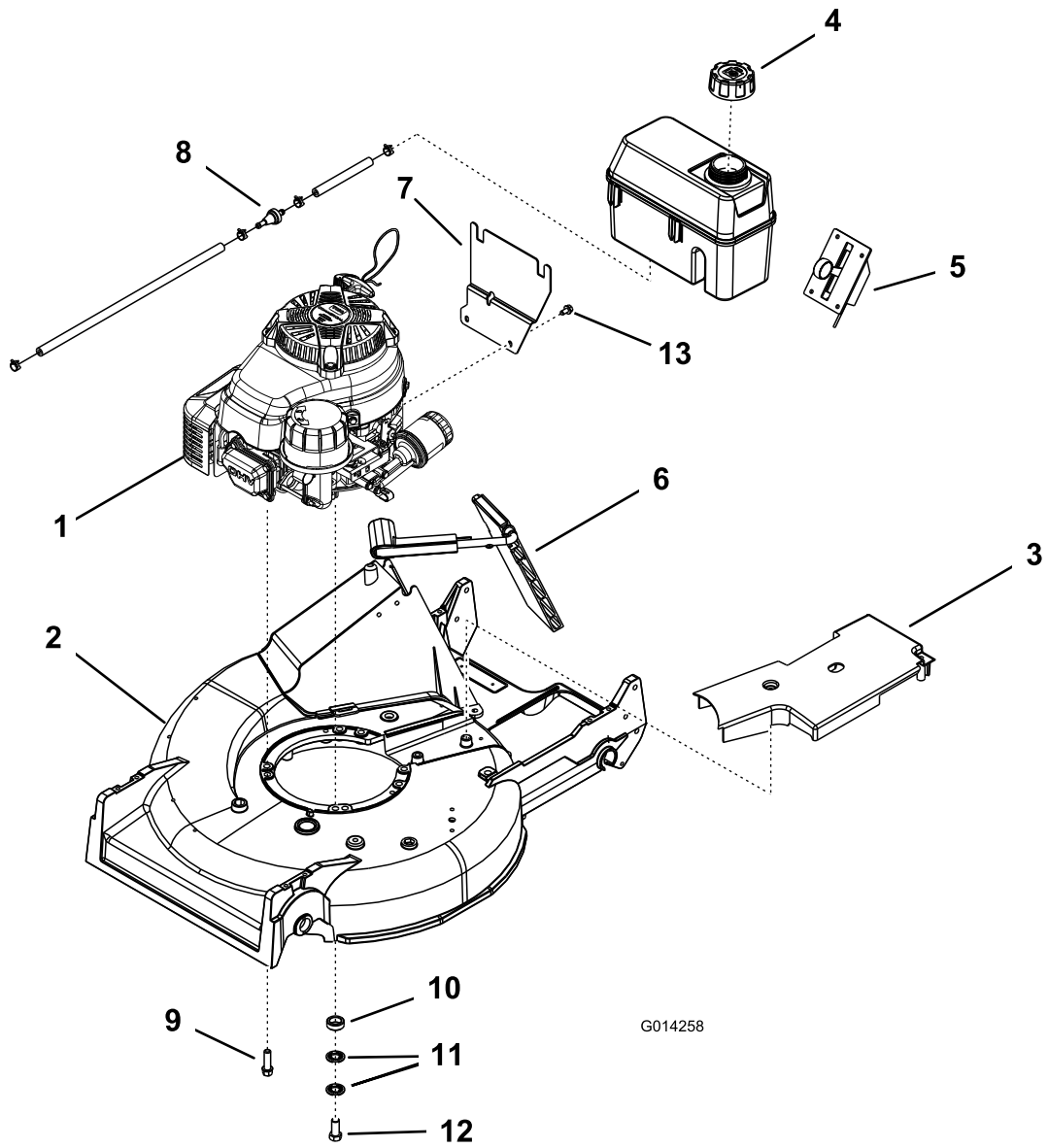

Figure 1

- | | |
|--|---|
| <ul style="list-style-type: none"> 1. Engine 2. Mower deck 3. Belt cover 4. Fuel tank cap 5. Throttle control 6. Discharge door 7. Tank bracket | <ul style="list-style-type: none"> 8. Fuel hose, fuel filter, and clamps 9. Engine mounting bolt (4) 10. Spacer 11. Spring washer 12. Blade bolt 13. Tank bracket screw |
|--|---|

2

Parts needed for this procedure:

1	Belt cover (74-1770)
1	Engine (117-5220)
1	Decal (110-0520)
4	Screw (95-1727)
1	Blade retainer spacer (103-3795)
1	Tank bracket (115-0954-03)
1	Fuel tank cap (93-7198)
3	Screw (104-2628)
1	Fuel hose (109-0296)
1	Fuel filter (71-9280)
4	Clamp (2412-98)
1	Fuel hose (109-0650)
4	Cable tie (3290-378)
1	Blade bolt
1	BBC spacer
2	Spring washer
1	Throttle control (117-3543)

Procedure

Note: Refer to Figure 1 for installing the new engine.

1. Install the new door on the discharge tunnel.
2. Install the tank bracket onto the engine using 3 screws (from the loose parts bag) and Loctite (242).

Note: Torque the screws to 70–120 in-lb.

3. Install the fuel tank onto the mounting bracket using 2 screws.

Note: Torque the screws to 40–50 in-lb.

4. Install the new engine on the mower housing.

Note: Torque the engine mounting bolts to 250–400 in-lb.

5. Install the BBC assembly.

Note: For information on installing the BBC assembly, refer to the *Walk Behind Power Mower Drive Systems Service Manual* (Form No. 492-4733).

6. Install the blade.

Note: Torque the blade nuts to 180–320 in-lb.

7. Attach the new fuel hose, fuel filter, and clamp to the engine and the fuel tank.

Note: The short hose attaches to the fuel tank.

8. Install and adjust the new throttle control cable.
9. Replace the belt cover.



Count on it.