



Count on it.

Parts Catalog

CE Kit Model 78531

48in E-Z Vac™ Bagger

Model No. 117-3827

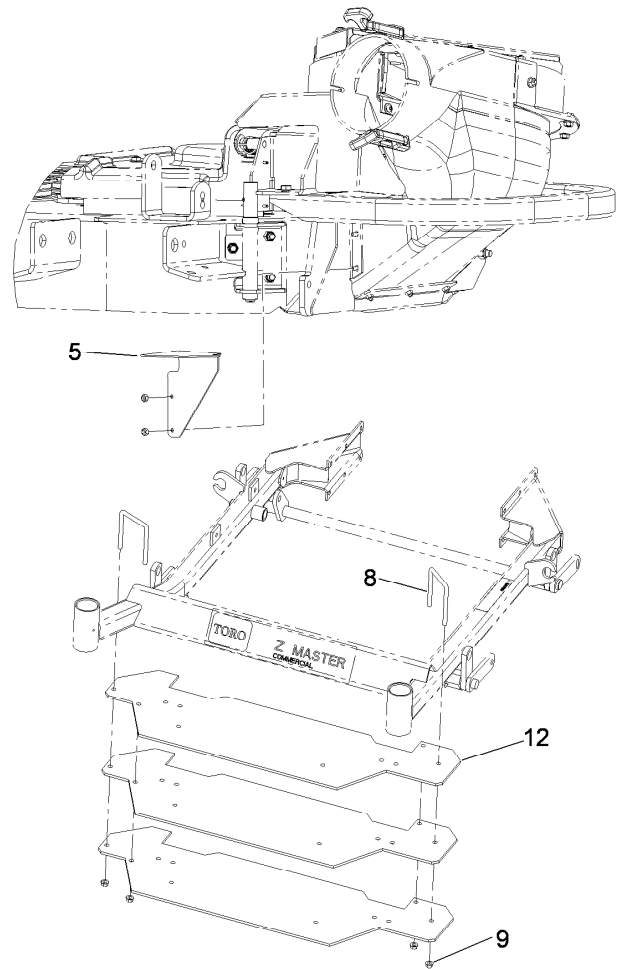
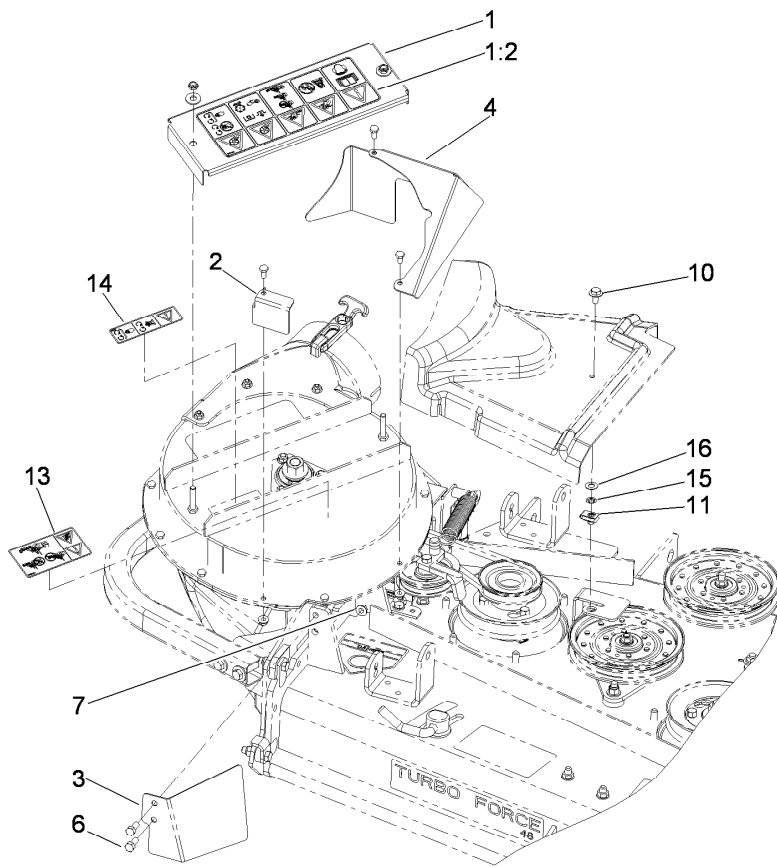

48 Inch E-Z Vac Bagger CE Kit No. 117-3827

Ref.	Part Number	Qty.	Description
1	117-0924	1	Cover-Bearing
1:2	117-0923	1	Decal-Danger
2	117-0926-03	1	Guard-Left
3	117-0927-03	1	Guard-Front
4	117-0928-03	1	Guard-Back
5	117-0929-03	1	Guard-Lower
6	322-43	2	Screw-HH
7	32128-25	2	Nut-HF
8	100-7067	2	U-Bolt

Ref.	Part Number	Qty.	Description
9	32128-21	4	Nut-HF
10	3234-7	1	Screw-HHF
11	94-2413	1	U-Nut
12	108-2770-01	3	Plate-Weight
13	117-0931	1	Decal-Warning
14	112-9028	1	Decal-Cover Missing
15	117-2749	1	Nut-Push
16	73-0041	1	Washer-Thrust