



CE Kit

for Model 78531 and 78541 48in E-Z Vac™ Bagger

Model No. 117-3827

Model No. 117-3828

Installation Instructions

Loose Parts

Use the chart below to verify that all parts have been shipped.

Procedure	Description	Qty.	Use
1	No parts required	–	Prepare the mower.
2	Warning decal Cover missing decal	1 1	Install the decals.
3	Blower cover Bolt (5/16 x 5/8 inch) U-nut Flat washer (5/16 inch) Push nut (5/16 inch)	1 1 1 1 1	Install the covers.
4	Left guard Back guard Front guard Lower guard Bolt (5/16 x 3/4 inch) Flange nut (5/16 inch)	1 1 1 1 2 2	Install the guards.
5	U-bolt (3/8 x 1 inch) Flange nut (3/8 inch) Weight	2 4 3	Install the mounting brackets.

1

Preparing the Mower

No Parts Required

Procedure

1. Thoroughly clean mower deck. All debris must be removed to ensure the kit will fit properly.
2. Repair all bent or damaged areas and replace any missing parts.

2

Installing the Decals

Parts needed for this procedure:

1	Warning decal
1	Cover missing decal

Procedure

1. Remove the existing blower cover (Figure 2). Save the hardware.
2. Clean the area where the decals will go (Figure 1).
3. Install the decals as shown in Figure 1.

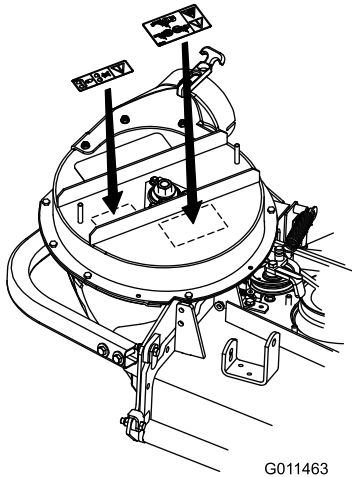

Figure 1

1. Cover missing decal
2. Warning decal

3

Installing the Covers

Parts needed for this procedure:

1	Blower cover
1	Bolt (5/16 x 5/8 inch)
1	U-nut
1	Flat washer (5/16 inch)
1	Push nut (5/16 inch)

Procedure

1. Remove the existing belt cover (Figure 2). Save all existing hardware
2. Remove the latch from the belt cover.
3. Drill a 11/32 inch diameter hole where the existing latch in the belt cover was installed (Figure 2).
4. Install the bolt (5/16 x 5/8 inch) into the cover and secure it to the belt cover with a washer (5/16 inch) and push nut (5/16 inch)(Figure 2).
5. Install the belt cover and tighten the bolt (5/16 x 5/8 inch) (Figure 2).
6. Install the U-nut into the belt cover bracket (Figure 2).
7. Install the new blower cover (Figure 2).

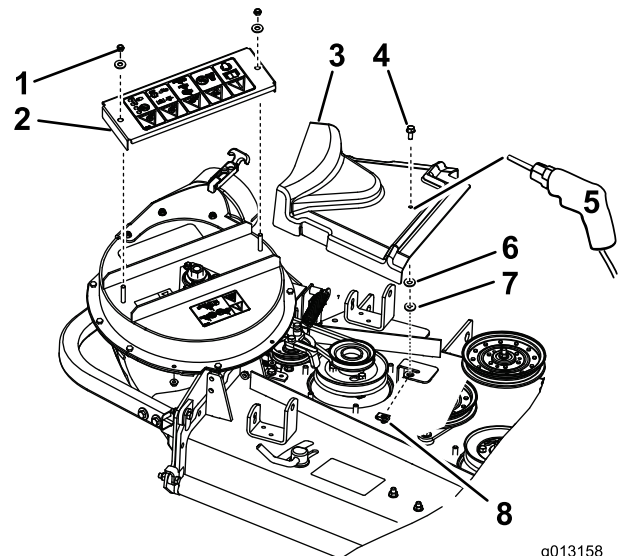

Figure 2

1. Existing hardware
2. New blower cover
3. Existing belt cover
4. Bolt (5/16 x 5/8 inch)
5. Drill a 11/32 inch diameter hole in the belt cover
6. Flat washer (5/16 inch)
7. Push nut (5/16 inch)
8. U-nut

4

Installing the Guards

Parts needed for this procedure:

1	Left guard
1	Back guard
1	Front guard
1	Lower guard
2	Bolt (5/16 x 3/4 inch)
2	Flange nut (5/16 inch)

Procedure

1. Remove the existing hardware around the blower for the left guard, lower guard and back guard (Figure 3). Save all existing hardware
2. Install the left guard with existing hardware (Figure 3).
3. Install the back guard with existing hardware (Figure 3).
4. Install the lower guard with existing hardware (Figure 3).
5. Install the front guard with a 2 bolts (5/16 x 3/4 inch) and 2 flange nuts (5/16 inch) (Figure 3).

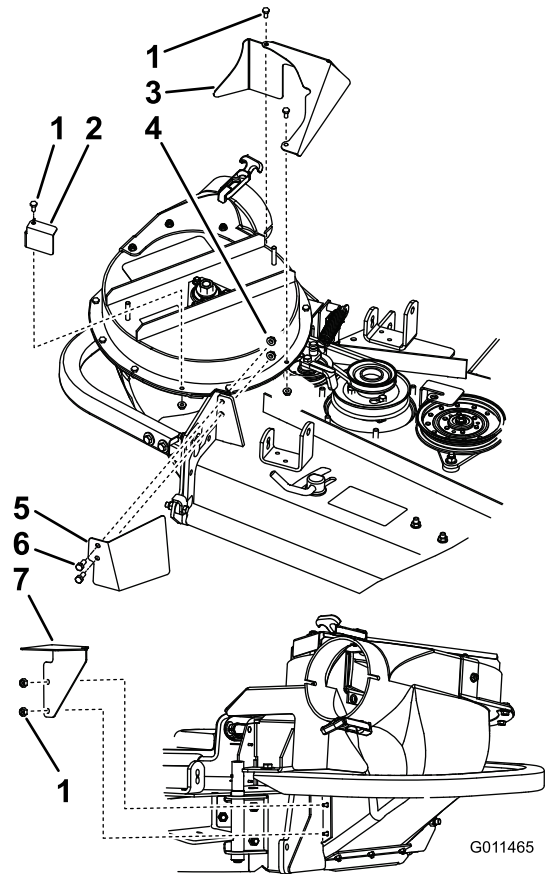

Figure 3

- | | |
|---------------------------|---------------------------|
| 1. Existing hardware | 5. Front guard |
| 2. Left guard | 6. Bolt (5/16 x 3/4 inch) |
| 3. Back guard | 7. Lower guard |
| 4. Flange nut (5/16 inch) | |

5

Installing the Mounting Brackets

Parts needed for this procedure:

2	U-bolt (3/8 x 1 inch)
4	Flange nut (3/8 inch)
3	Weight

Procedure

Do not use the weight that is shipped with the bagger.

Install the 3 weights under the footpan with 2 U-bolts and 4 flange nuts (3/8 inch) (Figure 4).

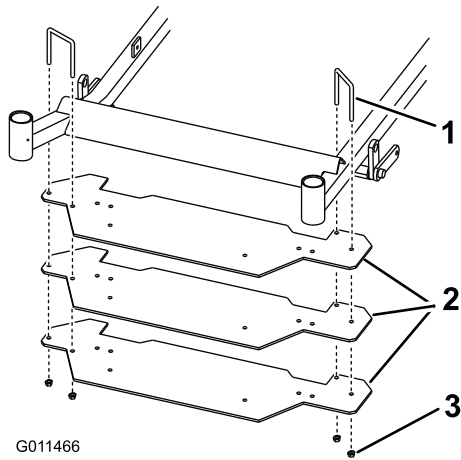

Figure 4

- 1. U-bolt
- 2. Weight
- 3. Flange nut