



Count on it.

Operator's Manual

**High-Torque Trencher Head
Compact Utility Loaders**

Model No. 22473—Serial No. 310000001 and Up

Model No. 22474—Serial No. 310000001 and Up

This product complies with all relevant European directives, for details please see the separate product specific Declaration of Conformity (DOC) sheet.

▲ DANGER

There may be buried power, gas, and/or telephone lines in the work area. Shock or explosion may occur if you dig into them.

Have the property or work area marked for buried lines and do not dig in marked areas. Contact your local marking service or utility company to have the property marked (for example, in the United States, call 811 for the nationwide marking service).

Introduction

The trencher heads are attachments designed for use on Toro compact utility loaders with a variety of booms and chains to dig trenches in soil to facilitate the burying of cabling and piping. They are not intended for use in cutting hard materials such as wood or concrete.

Read this information carefully to learn how to operate and maintain your product properly and to avoid injury and product damage. You are responsible for operating the product properly and safely.

You may contact Toro directly at www.Toro.com for product and accessory information, help finding a dealer, or to register your product.

Whenever you need service, genuine Toro parts, or additional information, contact an Authorized Service Dealer or Toro Customer Service and have the model and serial numbers of your product ready. Figure 1 identifies the location of the model and serial numbers on the product. Write the numbers in the space provided.

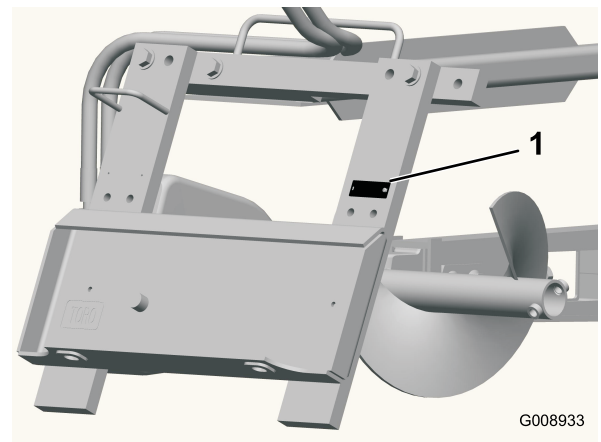

Figure 1

- 1. Model and serial number location

Model No. _____
Serial No. _____

This manual identifies potential hazards and has safety messages identified by the safety alert symbol (Figure 2), which signals a hazard that may cause serious injury or death if you do not follow the recommended precautions.



Figure 2

- 1. Safety alert symbol

This manual also uses 2 words to highlight information. **Important** calls attention to special mechanical information and **Note** emphasizes general information worthy of special attention.

Contents

Introduction.....	2
Safety	3
Stability Ratings.....	4
Safety and Instructional Decals	5
Setup.....	6
1 Installing the Boom and Digging Chain	6
2 Installing the Safety Bar.....	6
3 Installing the Spoils Auger.....	7
4 Checking the Bearing Case Lube Level.....	7
Product Overview	8

Specifications	8
Attachments/Accessories.....	8
Operation.....	9
Digging a Trench.....	9
Offsetting the Trencher	9
Transporting the Trencher on a Trailer	10
Operating Tips	10
Maintenance.....	11
Recommended Maintenance Schedule(s)	11
Greasing the Trencher	11
Servicing the Bearing Case Lube	11
Adjusting Digging Chain Tension	12
Flipping a Worn Boom	12
Replacing the Digging Teeth.....	13
Replacing the Drive Sprocket.....	13
Storage.....	14
Troubleshooting.....	15

Safety

Improper use or maintenance by the operator or owner can result in injury. To reduce the potential for injury, comply with these safety instructions and those in the traction unit *Operator’s Manual*. Always pay attention to the safety alert symbol, which means *Caution*, *Warning*, or *Danger*—personal safety instruction. Failure to comply with the instruction may result in personal injury or death.

⚠ DANGER

There may be buried power, gas, and/or telephone lines in the work area. Shock or explosion may occur if you dig into them.

Have the property or work area marked for buried lines and do not dig in marked areas. Contact your local marking service or utility company to have the property marked (for example, in the United States, call 811 for the nationwide marking service).

⚠ DANGER

The moving teeth and auger will severely cut hands, feet, or other body parts.

- Keep hands, feet, and any other part of your body or clothing away from moving teeth, auger, or other parts.
- Before adjusting, cleaning, repairing, or inspecting the trencher, lower the trencher to the ground, stop the engine, wait for all moving parts to stop, and remove the key.

⚠ WARNING

When the engine is off, attachments in the raised position can gradually lower. Someone nearby may be pinned or injured by the attachment as it lowers.

Always lower the attachment lift each time you shut off the traction unit.

⚠ WARNING

When going up or down hill, the machine could overturn if the heavy end is toward the downhill side. Someone may be pinned or seriously injured by the machine if it overturns.

Operate up and down slopes with the heavy end of the machine uphill. An attached trencher will make the front end heavy.

⚠ WARNING

If you do not fully seat the attachment locking pins in the attachment mount plate holes, the attachment could fall off of the traction unit severely injuring the operator or bystanders.

- Ensure that you fully seat the attachment locking pins through the holes in the attachment mount plate before lifting the attachment.
- Ensure that the attachment mount plate is free of any dirt or debris that may hinder the connection of the traction unit to the attachment.
- Refer to your traction unit *Operator's Manual* for detailed information on safely connecting an attachment to your traction unit.

⚠ WARNING

Lightning can cause severe injury or death. If lightning is seen or thunder is heard in the area, do not operate the machine; seek shelter.

⚠ CAUTION

Hydraulic fluid escaping under pressure can penetrate skin and cause injury. Fluid injected into the skin must be surgically removed within a few hours by a doctor familiar with this form of injury or gangrene may result.

- Keep your body and hands away from pin hole leaks or nozzles that eject high pressure hydraulic fluid.
- Use cardboard or paper to find hydraulic leaks, never use your hands.

⚠ CAUTION

Hydraulic couplers, hydraulic lines/valves, and hydraulic fluid may be hot and can burn you if you touch them.

- Wear gloves when operating the hydraulic couplers.
- Allow the traction unit to cool before touching hydraulic components.
- Do not touch hydraulic fluid spills.

Stability Ratings



To determine the degree of slope you can traverse with the trencher installed on a traction unit, find the stability rating for the hill position you want to travel in the appropriate table below, then find the degree of slope for the same rating and hill position in the Stability Data section of the traction unit *Operator's Manual*.

⚠ WARNING

Exceeding the maximum recommended slope can cause the traction unit to tip, crushing you or bystanders.

Do not drive the traction unit on a slope steeper than the maximum recommended slope, as determined in the following tables and the traction unit *Operator's Manual*.

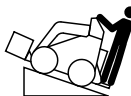
Important: If you have a traction unit other than a TX compact utility loader, use the counterweight on the traction unit when using the trencher. Failure to use the counterweight will cause the traction unit to become unstable.

Orientation	Stability Rating
Front Uphill 	C
Rear Uphill 	D
Side Uphill 	C

Safety and Instructional Decals



Safety decals and instructions are easily visible to the operator and are located near any area of potential danger. Replace any decal that is damaged or lost.

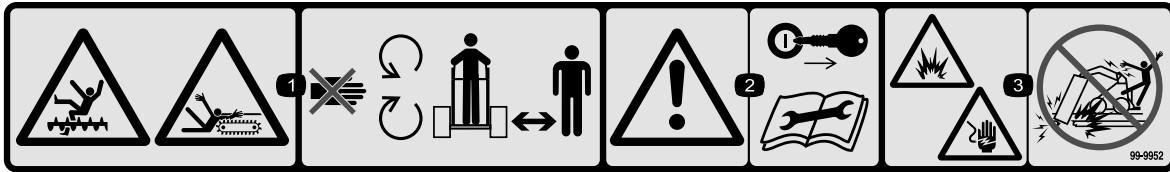

99-9952

1. Cutting hazard, chain and auger—stay away from moving parts and keep bystanders away from the machine.
2. Warning—stop the engine and remove the key before performing maintenance or repairs.
3. Explosion and/or electric shock hazard—do not dig in areas with buried gas or power lines.



99-9953

1. Explosion and/or electric shock hazard—do not dig in areas with buried gas or power lines.

Setup

1

Installing the Boom and Digging Chain

Parts needed for this procedure:

1	Boom assembly (sold separately)
1	Chain assembly (sold separately)

Procedure

1. Raise the trencher about 6 inches (15 cm) off of the ground.
2. Stop the engine and remove the key.
3. Remove the bolt and nut securing the spoils auger and remove the auger (Figure 3). Save the bolt and nut for future use.

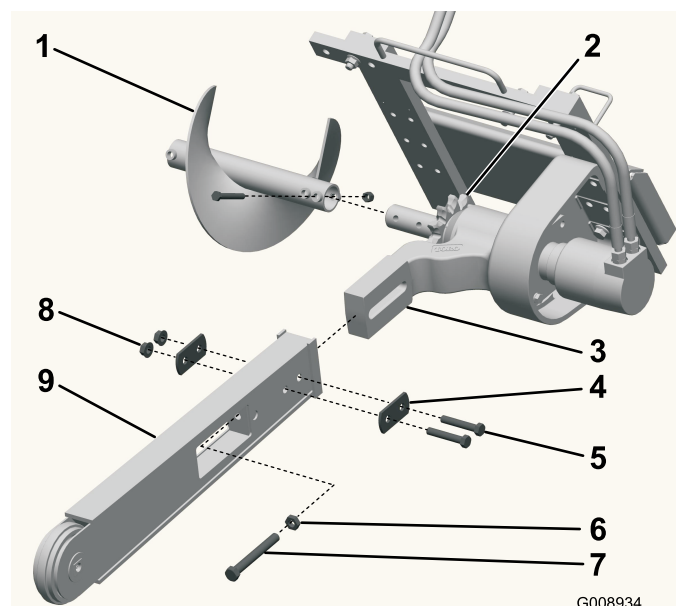

Figure 3

- | | |
|--------------------------|-------------------|
| 1. Spoils auger | 6. Jam nut |
| 2. Drive sprocket | 7. Adjusting bolt |
| 3. Arm on the drive head | 8. Nuts |
| 4. Double washer | 9. Boom |
| 5. Bolts | |

4. Remove the 2 bolts, nuts, and double washers from the sides of the boom (Figure 3).
5. Loosen the adjusting bolt and jam nut (Figure 3).
6. Slide the boom over the arm on the drive head.

7. Install the 2 bolts, nuts, and double washers removed previously through the boom and arm, but do not tighten them.
8. If the chain is not connected, connect the links by pressing or hammering the clevis pin supplied with the chain through the links.

Important: To avoid bending the chain links, place blocks under and between the links when hammering the clevis pin through.

9. Secure the clevis pin with the cotter pin supplied with the chain.
10. Loop the digging chain over the auger drive shaft and onto the drive sprocket, ensuring that the digging teeth point forward on the upper span.
11. Set the upper span of the chain into place on the trencher boom, then wrap the chain around the roller at the end of the boom.
12. Thread the adjustment bolt into the boom and turn it in until there is 1-1/2 to 2-1/2 inches (3.8 to 6.3 cm) of slack in the chain on the bottom span.
13. Thread the jam nut down the adjusting bolt and tighten it securely against the boom.
14. Torque the 2 bolts and nuts securing the boom to 135 to 165 ft-lb (183 to 223 N-m).

2

Installing the Safety Bar

Parts needed for this procedure:

1	Safety bar
1	Safety bar extension (with booms over 2 ft (61 cm) only)
2	Bolts (with booms over 2 ft (61 cm) only)
2	Locknuts (with booms over 2 ft (61 cm) only)

Procedure

1. Remove the 3 bolts, washers, and flange nuts from the upper left corner of the trencher frame (Figure 4).

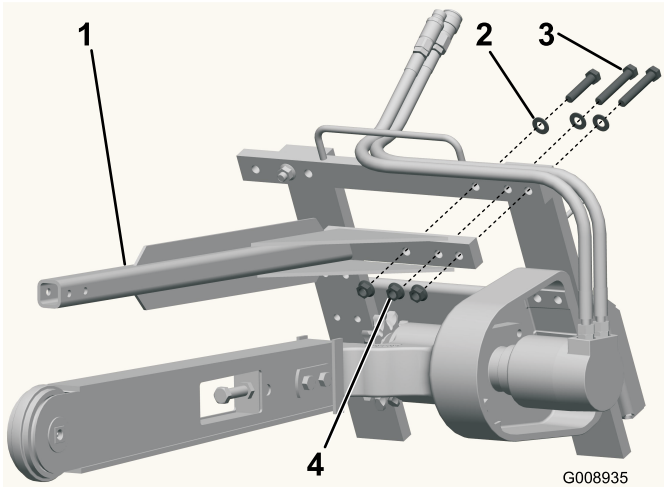

Figure 4

- | | |
|---------------|----------------|
| 1. Safety bar | 3. Bolts |
| 2. Washers | 4. Flange nuts |

2. Using the fasteners removed previously, install the trencher safety bar as illustrated in Figure 4.
3. Torque the bolts and nuts to 190 to 230 ft-lb (257 to 311 N-m).
4. If you have a boom over 2 ft (61 cm), secure the safety bar extension (supplied with the boom) over the end of the safety bar and secure it using the 2 bolts and locknuts supplied with the extension.

3

Installing the Spoils Auger

No Parts Required

Procedure

Before operating the trencher, install and position the spoils auger to work correctly with the digging chain configuration you are using. Failure to position the spoils auger correctly may damage the trencher.

1. To install and position the auger, use the bolt and nut removed from the auger previously to secure it in the correct holes, as described in the following list:

Note: Refer to Figure 5 when performing this procedure.

- 4 inch (10 cm) chain configuration

Using the hole closest to the auger blade in the end of the auger with two holes, connect the auger to the inner hole on the shaft.

- 6 inch (15 cm) chain configuration
Using the hole farthest from the auger blade in the end of the auger with two holes, connect the auger to the inner hole on the shaft.
- 8 inch (20 cm) chain configuration
Using the end of the auger with one hole, connect the auger to the inner hole on the shaft.
- 12 inch (25 or 30 cm) chain configuration
Using the end of the auger with one hole, connect the auger to the outer hole on the shaft.

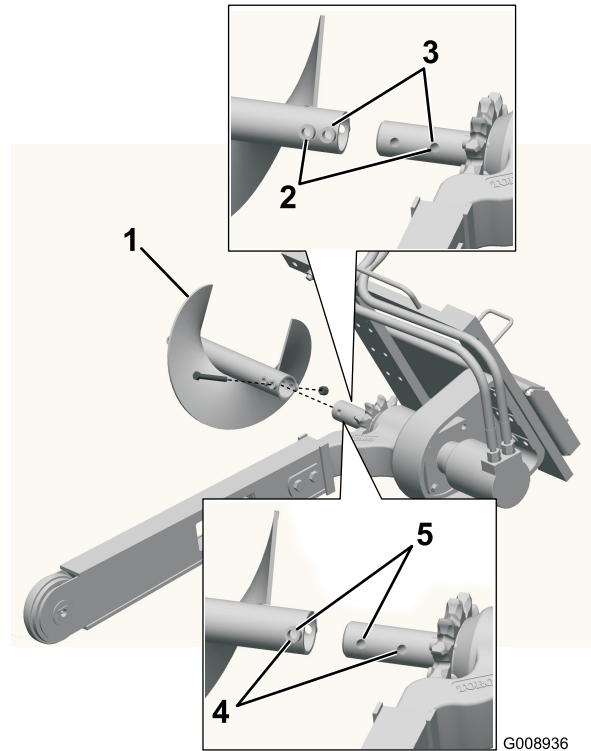

Figure 5

1. Auger
2. Connect these holes for a 4 inch (10 cm) chain
3. Connect these holes for a 6 inch (15 cm) chain
4. Connect these holes for a 8 inch (20 cm) chain
5. Connect these holes for a 12 inch (30 cm) chain

2. Torque the bolt and nut to 75 ft-lb (101 N-m).

4

Checking the Bearing Case Lube Level

No Parts Required

Procedure

Before operating the trencher, check to ensure that the bearing case is filled with gear lube.

1. Lower the trencher to the ground on a flat, level surface and tilt it so that the boom is parallel with the ground.
2. Stop the engine and remove the key.
3. Clean the area around the bearing case fill hole plug (Figure 6).

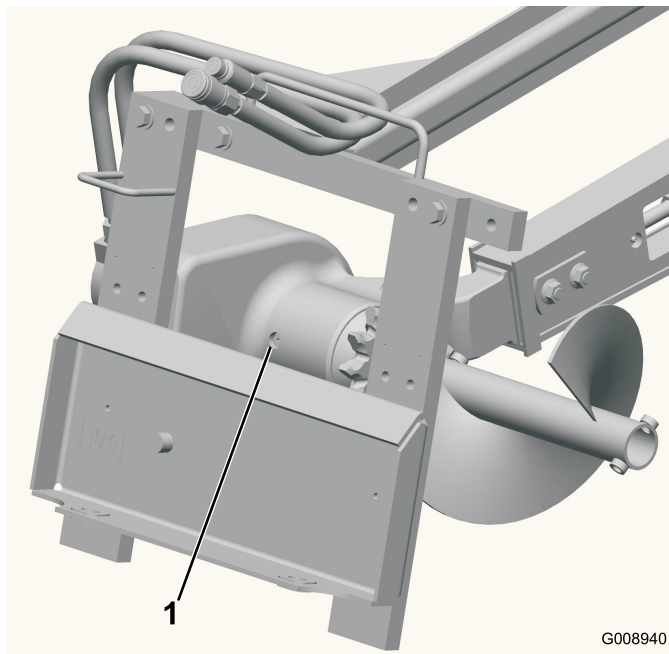

Figure 6

1. Bearing case fill hole plug

4. Remove the plug from the bearing case fill hole (Figure 6).
5. Look in the hole, the level should be up to the bottom of the hole; if not add gear lube until it comes out of the hole.
6. Replace the plug and torque it to 15 to 17 ft-lb (20 to 23 N-m).

Product Overview

Specifications

Note: Specifications and design are subject to change without notice.

Width, with 3 ft (91 cm) boom	35 inches (89 cm)
Length, with 3 ft (91 cm) boom	65 inches (165 cm)
Height, with 3 ft (91 cm) boom	24 inches (61 cm)
Weight, with 3 ft (91 cm) boom	390 lb (177 Kg)
Maximum trench depth, 2 ft (61 cm) boom	24 inches (61 cm) at a 65 degree boom angle
Maximum trench depth, 3 ft (91 cm) boom	36 inches (91 cm) at a 65 degree boom angle
Maximum trench depth, 4 ft (122 cm) boom	48 inches (122 cm) at a 65 degree boom angle

Attachments/Accessories

A selection of Toro approved attachments and accessories are available for use with the machine to enhance and expand its capabilities. Contact your Authorized Service Dealer or Distributor or go to www.Toro.com for a list of all approved attachments and accessories.

Operation

Refer to your traction unit *Operator's Manual* for more information on installing and removing attachments on your traction unit.

Important: Always use the traction unit to lift and move the attachment.

Digging a Trench

1. If your traction unit has a speed selector, set it to the slow (turtle position), then start the engine.
2. Pull the auxiliary hydraulics lever to the operator grip to engage the trencher.
3. Slowly lower the trencher to the ground so that the boom and chain are parallel to the ground.
4. Begin inserting the nose of the boom and chain into the ground by slowly raising the trencher a few inches off the ground while tilting the nose down into the ground gradually.
5. Once the trencher boom is in the ground at a 45 to 60 degree angle, slowly lower the trencher until the spoils auger is just above the ground.
6. Ensure that all parts of the trencher are functioning correctly.
7. Slowly move the traction unit rearward to extend the trench.

Note: If you move too fast, the trencher will stall. If it stalls, raise it slightly, slowly drive forward, or reverse the chain direction momentarily.

8. When finished, raise the trencher and boom out of the trench by tilting the attachment rearward, then stop the trencher by moving the auxiliary hydraulics lever into neutral.

Offsetting the Trencher

You can move the trencher to the right side of the trencher frame to allow you to trench close to buildings and other obstacles.

1. Lower the trencher to the ground, stop the engine, and disconnect the hydraulic lines from the trencher.

⚠ WARNING

Hydraulic fluid escaping under pressure can penetrate skin and cause injury. Fluid injected into the skin must be surgically removed within a few hours by a doctor familiar with this form of injury or gangrene may result.

- Keep your body and hands away from pin hole leaks or nozzles that eject high pressure hydraulic fluid.
 - Use cardboard or paper to find hydraulic leaks, never use your hands.
2. Remove the 6 bolts securing the trencher head to the frame (Figure 7).

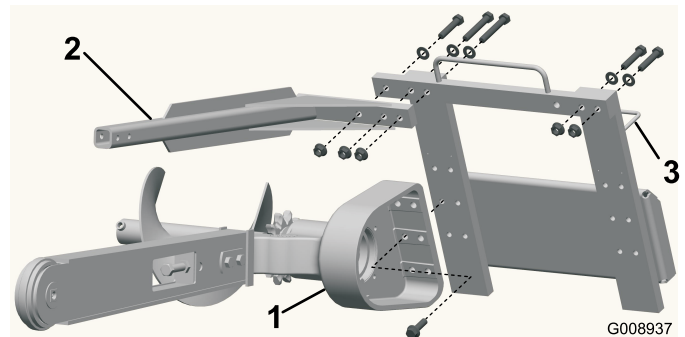

Figure 7

1. Trencher head (simplified for illustrative purposes)
2. Safety bar
3. Side hose guide for illustrative purposes

3. Move the frame to the left, aligning the holes in the right side of the frame with those in the head.
4. Attach the head to the frame with the 6 bolts removed previously (Figure 7).
5. Torque the bolts to 190 to 230 ft-lb (257 to 311 N-m).
6. Remove the 3 bolts, washers, and flange nuts from the safety bar and remove the bar (Figure 7).
7. Remove the 2 short bolts, washers, and flange nuts securing the right side of the upper frame and move them to the corresponding holes on the left (Figure 7).
8. Install the safety bar over the trencher chain using the 3 bolts, washers, and flange nuts removed previously (Figure 7).
9. Torque all 5 bolts and nuts to 190 to 230 ft-lb (257 to 311 N-m).
10. Move the hoses from the hose guide on top of the trencher to the hose guide on the left side (Figure 7).

Transporting the Trencher on a Trailer

Place the trencher on a trailer or truck capable of carrying it. Securely tie the trencher to the trailer or truck using tie straps appropriate for the weight of the trencher and for highway use.

Operating Tips

- Clean the area of trash, branches and rocks before trenching to prevent equipment damage.
- Always begin trenching with the slowest ground speed possible. Increase speed if conditions permit.
- Always use full throttle (maximum engine speed) when trenching.
- Always trench backwards (i.e., in reverse).
- Never transport the trencher with the loader arms raised. Keep the arms lowered and the trencher tilted up.
- When trenching, the spoils auger should just clear the original ground surface to obtain maximum soil removal.
- Trench at a 45 to 60 degree angle for best results.
- You will be able to dig a trench faster by controlling the depth with periodic adjustments of the loader arms.
- If your traction unit has a speed selector (present on some wheeled traction units), set it to the slow (turtle position).
- If your traction unit has a flow divider (present on some wheeled traction units), adjust it to approximately the 10 o'clock position.
- If the trencher binds in the soil, push the auxiliary hydraulics lever fully forward to reverse the chain direction. Once the chain is loose, pull the lever rearward again and continue trenching.
- If you need the finished trench to be cleaner than what is possible with the trencher, you can purchase a crumber from your dealer. The crumber mounts onto the trencher and scrapes the trench clean as you run the trencher.
- To improve the quality of trenches less than 24 inches (61 cm) deep, use a 24 inch (61 cm) boom on the trencher.

Maintenance

Recommended Maintenance Schedule(s)

Maintenance Service Interval	Maintenance Procedure
Before each use or daily	<ul style="list-style-type: none">• Grease the trencher.• Inspect the digging teeth and chain for excessive wear.
Every 25 hours	<ul style="list-style-type: none">• Check the gear lube level.• Adjust the digging chain tension.• Inspect the boom for wear.
Every 200 hours	<ul style="list-style-type: none">• Change the gear lube.
Before storage	<ul style="list-style-type: none">• Grease the trencher.• Check the gear lube level.• Paint chipped surfaces.

⚠ CAUTION

If you leave the key in the ignition switch, someone could start the engine. Accidental starting of the engine could seriously injure you or other bystanders.

Remove the key from the ignition switch before you do any maintenance.

Greasing the Trencher

Service Interval: Before each use or daily

Before storage

Grease 2 fittings, as shown in Figure 8 and Figure 9, every day and immediately after every washing.

Grease Type: General-purpose grease

1. Stop the engine and remove the key.
2. Clean the grease fittings with a rag.
3. Connect a grease gun to each fitting.
4. Pump grease into the fittings until grease begins to ooze out of the bearings.
5. Wipe up any excess grease.

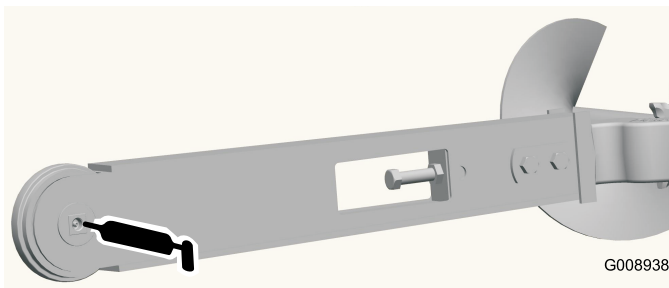

Figure 8

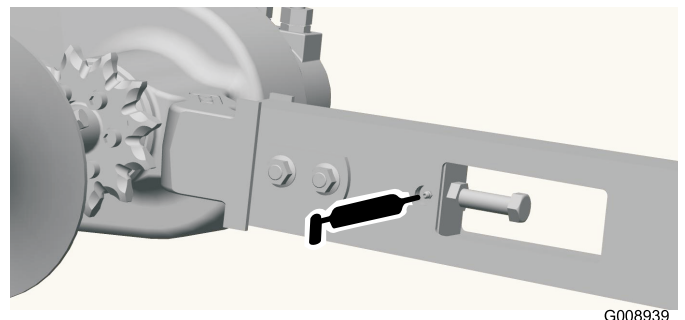

Figure 9

Servicing the Bearing Case Lube

Service Interval: Every 25 hours

Every 200 hours

Before storage

Gear lube type: SAE 90-140 API service GL-4 or GL-5

Refill capacity: 1 pint (1/2 l).

Checking the Bearing Case Lube

1. Lower the trencher to the ground on a flat, level surface and tilt it so that the boom is parallel with the ground.
2. Stop the engine and remove the key.
3. Clean the area around the bearing case fill hole plug (Figure 10).

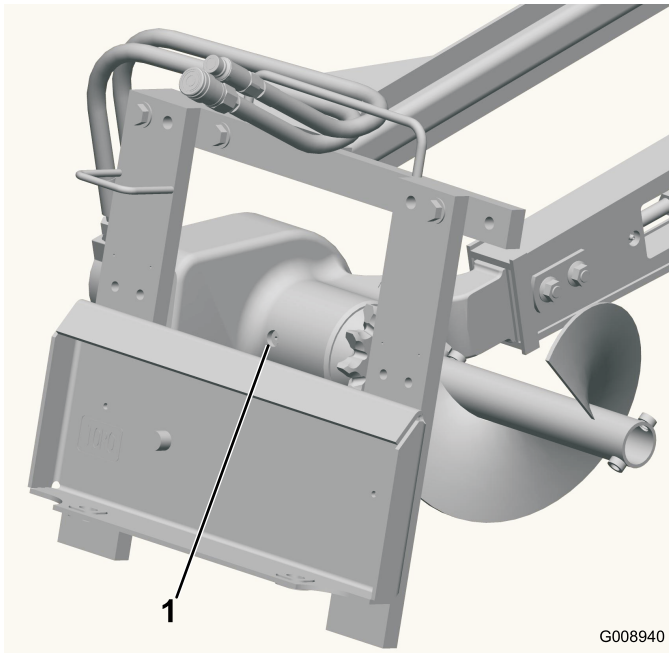

Figure 10

1. Bearing case fill hole plug

4. Remove the plug from the bearing case fill hole (Figure 10).
5. Look in the hole, the level should be up to the bottom of the hole; if not add gear lube until it comes out of the hole.
6. Replace the plug and torque it to 15 to 17 ft-lb (20 to 23 N-m).

Changing the Gear Lube

1. Clean the area around the bearing case fill hole plug (Figure 10).
2. Remove the plug from the bearing case fill hole (Figure 10).
3. Lift the trencher until the boom is vertical, draining the lube through the fill hole and into a pan.
4. Return the trencher to the ground.
5. Fill the bearing case with gear lube until it comes out of the fill hole.
6. Replace the plug and torque it to 15 to 17 ft-lb (20 to 23 N-m).

Adjusting Digging Chain Tension

Service Interval: Every 25 hours

With the trencher parallel to the ground, ensure that there are 1-1/2 to 2-1/2 inches (3.8 to 6.3 cm) between the bottom of the boom and the top of the bottom chain span. If not, adjust the chain using the following procedure:

Important: Do not over tighten the chain. Excess chain tension may damage drive components.

1. Loosen the 2 bolts and nuts securing the boom to the trencher arm (Figure 3).
2. Loosen the jam nut securing the adjustment bolt (Figure 3).
3. Turn the adjustment bolt in or out as needed to achieve the desired tension.
4. Tighten the jam nut.
5. Torque the 2 bolts and nuts securing the boom to 135 to 165 ft-lb (183 to 223 N-m).

Flipping a Worn Boom

Service Interval: Every 25 hours

Inspect the bottom of the boom for wear, if it is worn, complete the following:

Note: If you have already flipped the boom once, replace the boom when both sides are worn.

1. Remove the 2 bolts and nuts securing the boom to the trencher arm (Figure 3).
2. Loosen the jam nut on the adjusting bolt in the boom (Figure 3).
3. Loosen the adjusting bolt until you can remove the chain from the boom (Figure 3).
4. Remove the chain from the drive sprocket.
5. Remove the boom, flip it over so the bottom becomes the top (or if you have already flipped it once, replace it), and install the boom again.
6. Replace the nuts, bolts, and washers securing the boom.
7. Install the chain over the drive sprocket and front roller.
8. Adjust the chain tension as described in Adjusting the Digging Chain Tension.

Replacing the Digging Teeth

Service Interval: Before each use or daily

Due to the high amount of wear placed on the digging teeth, you will need to replace them periodically.

To replace a single tooth, remove the bolts securing the tooth to remove it, then install a new tooth in the same position. Torque the bolts securing the teeth to 27 to 33 ft-lb (37 to 45 N-m).

Replacing the Drive Sprocket

Overtime, the drive sprocket will wear, especially when used in sandy or clay soils. When this happens, the digging chain will begin to slip. If the chain slips, replace the drive sprocket, as follows:

1. Raise the trencher a few inches above the ground.
2. Stop the engine and remove the key.
3. Remove the spoils auger (Fig. 8).

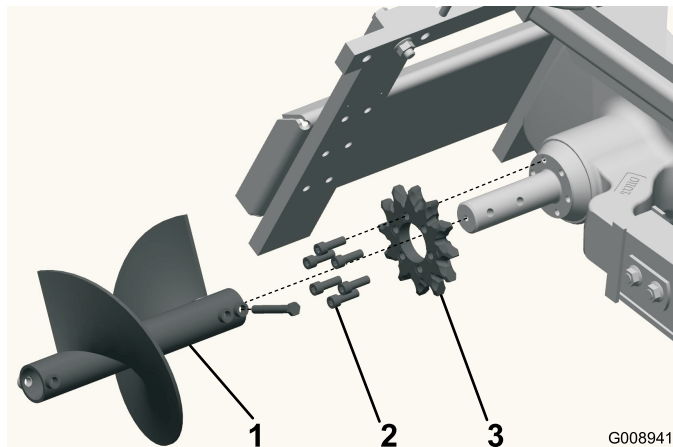

Figure 11

1. Spoils auger
2. Drive sprocket
3. Bolts

Important: The arrow on the sprocket face should be visible from the right side of the trencher and should point in a clockwise direction; if not, turn the sprocket around.

12. Thread the 6 bolts into the sprocket finger tight (Fig. 8).
13. Slowly begin tightening the bolts progressing around the sprocket until all bolts are torqued to 95 to 115 ft-lb (129 to 155 N-m).

Important: Tighten each bolt only half way first, working your way around the six bolts, then return to each bolt in turn and torque them to the specifications given in step 13.

14. Loop the chain over the auger drive shaft and onto the drive sprocket, ensuring that the teeth point forward on the upper span.
15. Set the upper span of the chain into place on the trencher boom, then wrap the chain around the roller at the end of the boom.
16. Thread the adjustment bolt into the boom and turn it in until there is 1-1/2 to 2-1/2 inches (3.8 to 6.3 cm) of slack in the chain on the bottom span.
17. Thread the jam nut down the adjusting bolt and tighten it securely against the boom.
18. Torque the 2 bolts and nuts securing the boom to 135 to 165 ft-lb (183 to 223 N-m).
19. Install the spoils auger; refer to Installing the Spoils Auger.

4. Loosen the 2 bolts and nuts securing the boom to the trencher arm (Fig. 2).
5. Loosen the jam nut on the adjusting bolt in the boom (Fig. 2).
6. Loosen the adjusting bolt until you can remove the chain from the boom (Fig. 2).
7. Remove the chain from the drive sprocket.
8. Remove the 6 bolts securing the drive sprocket (Fig. 8).
9. Remove and discard the drive sprocket (Fig. 8).
10. Clean the sprocket mounting surface on the trencher.
11. Slide the new sprocket onto the shaft as illustrated in Figure 8.

Storage

1. Before long term storage, brush the dirt from the attachment.
2. Check the condition of the digging chain. Adjust and lubricate the chain. Replace any worn or damaged teeth.
3. Check and tighten all bolts, nuts, and screws. Repair or replace any part that is damaged or worn.
4. Ensure that all hydraulic couplers are connected together to prevent contamination of the hydraulic system.
5. Paint all scratched or bare metal surfaces. Paint is available from your Authorized Service Dealer.
6. Store the trencher in a clean, dry garage or storage area. Cover the trencher to protect it and keep it clean.

Troubleshooting

Problem	Possible Cause	Corrective Action
The chain does not turn.	<ol style="list-style-type: none"> 1. A hydraulic coupler is not completely connected. 2. A hydraulic coupler is damaged. 3. There is an obstruction in a hydraulic hose 4. An auxiliary valve on the traction unit is not opening. 5. The boom end bearing failed. 6. The digging chain is too tight. 7. There is sand buildup in tooth root of the drive sprocket. 8. Hydraulic motor or chain drive failure 	<ol style="list-style-type: none"> 1. Check and tighten all couplers. 2. Check/replace couplers 3. Find and remove the obstruction. 4. Repair the valve. 5. Replace the bearing. 6. Adjust the digging chain. 7. Raise the trencher and run the chain backwards, then reduce the chain tension. 8. Contact your Authorized Service Dealer.
The trencher does not dig fast enough.	<ol style="list-style-type: none"> 1. Worn teeth 2. Wrong setting on flow divider and speed lever (applicable wheeled units only) 3. There is a restriction in a quick coupler or hose. 4. The hydraulic system is too hot. 5. The relief valve is set below specifications. 	<ol style="list-style-type: none"> 1. Replace any worn teeth. 2. Set the flow divider to the 10:00 position and the speed lever to the turtle position. 3. Check the hoses and couplers and repair any problems found. 4. Shutdown and allow the system to cool. 5. Contact your Authorized Service Dealer.
The chain turns in the wrong direction	<ol style="list-style-type: none"> 1. The auxiliary valve lever is in the wrong position. 2. The hydraulic hoses are reversed. 	<ol style="list-style-type: none"> 1. Move the auxiliary valve lever to the rearward position. 2. Disconnect hoses and switch positions.
The bearing case lube is contaminated.	<ol style="list-style-type: none"> 1. The fill plug is leaking. 2. O-ring failure on the motor. 3. Seal failure. 	<ol style="list-style-type: none"> 1. Look for moisture around the fill plug. If present, change the oil, and replace the plug and the plug o-ring. 2. Contact your Authorized Service Dealer. 3. Contact your Authorized Service Dealer.



Toro Compact Utility Equipment Warranty

A One-Year Limited Warranty

CUE Products

Conditions and Products Covered

The Toro® Company and its affiliate, Toro Warranty Company, pursuant to an agreement between them, jointly warrant your Toro Compact Utility Equipment ("Product") to be free from defects in materials or workmanship. The following time periods apply from the date of purchase:

Products	Warranty Period
Loaders, Trenchers and Attachments	1 year or 1000 operating hours, whichever occurs first
Kohler Engines	3 years
All other Engines	2 years

Where a warrantable condition exists, we will repair the Product at no cost to you including diagnosis, labor, and parts.

Instructions for Obtaining Warranty Service

If you think that your Toro Product contains a defect in materials or workmanship, follow this procedure:

1. Contact any Authorized Toro Compact Utility Equipment (CUE) Service Dealer to arrange service at their dealership. To locate a dealer convenient to you, access our website at www.Toro.com. You may also call our Toro Customer Care Department toll free at 888-865-5676 (U.S. customers) or 888-865-5691 (Canadian customers).
2. Bring the product and your proof of purchase (sales receipt) to the Service Dealer.
3. If for any reason you are dissatisfied with the Service Dealer's analysis or with the assistance provided, contact us at:

LCB Customer Care Department
 Toro Warranty Company
 8111 Lyndale Avenue South
 Bloomington, MN 55420-1196
 Toll Free: 888-865-5676 (U.S. customers)
 Toll Free: 888-865-5691 (Canada customers)

Owner Responsibilities

You must maintain your Toro Product by following the maintenance procedures described in the *Operator's Manual*. Such routine maintenance, whether performed by a dealer or by you, is at your expense. Parts scheduled for replacement as required maintenance ("Maintenance Parts"), are warranted for the period of time up to the scheduled replacement time for that part. Failure to perform required maintenance and adjustments can be grounds for disallowing a warranty claim.

Items and Conditions Not Covered

Not all product failures or malfunctions that occur during the warranty period are defects in materials or workmanship. This express warranty does not cover the following:

- Product failures which result from the use of non-Toro replacement parts, or from installation and use of add-on, modified, or unapproved accessories
- Product failures which result from failure to perform required maintenance and/or adjustments
- Product failures which result from operating the Product in an abusive, negligent or reckless manner
- Parts subject to consumption through use unless found to be defective. Examples of parts which are consumed, or used up, during normal Product operation include, but are not limited to, digging teeth, tines, spark plugs, tires, tracks, filters, chains, etc.
- Failures caused by outside influence. Items considered to be outside influence include, but are not limited to, weather, storage practices, contamination, use of unapproved coolants, lubricants, additives, or chemicals, etc.
- Normal "wear and tear" items. Normal "wear and tear" includes, but is not limited to, worn painted surfaces, scratched decals or windows, etc.
- Any component covered by a separate manufacturer's warranty
- Pickup and delivery charges

General Conditions

Repair by an Authorized Toro Compact Utility Equipment (CUE) Service Dealer is your sole remedy under this warranty.

Neither The Toro® Company nor Toro Warranty Company is liable for indirect, incidental or consequential damages in connection with the use of the Toro Products covered by this warranty, including any cost or expense of providing substitute equipment or service during reasonable periods of malfunction or non-use pending completion of repairs under this warranty. All implied warranties of merchantability and fitness for use are limited to the duration of this express warranty. Some states do not allow exclusions of incidental or consequential damages, or limitations on how long an implied warranty lasts, so the above exclusions and limitations may not apply to you.

This warranty gives you specific legal rights, and you may also have other rights which vary from state to state.

Except for the engine warranty coverage and the Emissions warranty referenced below, if applicable, there is no other express warranty. The Emissions Control System on your Product may be covered by a separate warranty meeting requirements established by the U.S. Environmental Protection Agency (EPA) or the California Air Resources Board (CARB). The hour limitations set forth above do not apply to the Emissions Control System Warranty. Refer to the California Emission Control Warranty Statement supplied with your Product or contained in the engine manufacturer's documentation for details.

Countries Other than the United States or Canada

Customers who have purchased Toro products exported from the United States or Canada should contact their Toro Distributor (Dealer) to obtain guarantee policies for your country, province, or state. If for any reason you are dissatisfied with your Distributor's service or have difficulty obtaining guarantee information, contact the Toro importer. If all other remedies fail, you may contact us at Toro Warranty Company.