



**Count on it.**

**Operator's Manual**

**Bore Drive Head Attachment**

**Compact Utility Loader**

**Model No. 22420—Serial No. 31000001 and Up**

**▲ DANGER**

There may be buried power, gas, and/or telephone lines in the work area. Shock or explosion may occur if you dig into them.

Have the property or work area marked for buried lines and do not dig in marked areas. Contact your local marking service or utility company to have the property marked (for example, in the United States, call 811 for the nationwide marking service).

This product complies with all relevant European directives, for details please see the separate product specific Declaration of Conformity (DOC) sheet.

# Introduction

The bore drive head is an attachment intended for use with Toro compact utility loaders to bore holes under paved surfaces and pull either wires or piping back through the hole under the pavement. It is intended for boring through soil and gravel. It is not designed to bore through rock, wood, or other hard materials.

Read this information carefully to learn how to operate and maintain your product properly and to avoid injury and product damage. You are responsible for operating the product properly and safely.

You may contact Toro directly at [www.Toro.com](http://www.Toro.com) for product and accessory information, help finding a dealer, or to register your product.

Whenever you need service, genuine Toro parts, or additional information, contact an Authorized Service Dealer or Toro Customer Service and have the model and serial numbers of your product ready. The model and serial numbers are printed on a plate located on the right side of the drive head. Write the numbers in the space provided.

<p><b>Model No.</b> _____</p> <p><b>Serial No.</b> _____</p>
--

This manual identifies potential hazards and has safety messages identified by the safety alert symbol (Figure 1), which signals a hazard that may cause serious injury or death if you do not follow the recommended precautions.



Figure 1

1. Safety alert symbol

This manual also uses 2 words to highlight information. **Important** calls attention to special mechanical information and **Note** emphasizes general information worthy of special attention.

# Contents

- Introduction..... 2
- Safety ..... 3
  - Stability Ratings..... 4
  - Safety and Instructional Decals ..... 4
- Product Overview ..... 5
  - Specifications ..... 5
  - Attachments/Accessories..... 5
- Operation..... 5
  - Installing Accessories ..... 5
  - Removing an Accessory..... 5
  - Boring a Hole..... 6
- Storage..... 8
- Troubleshooting..... 9

# Safety

Improper use or maintenance by the operator or owner can result in injury. To reduce the potential for injury, comply with these safety instructions and those in the traction unit *Operator's Manual*. Always pay attention to the safety alert symbol, which means *Caution*, *Warning*, or *Danger*—personal safety instruction. Failure to comply with the instruction may result in personal injury or death.

## ⚠ DANGER

There may be buried power, gas, and/or telephone lines in the work area. Shock or explosion may occur if you dig into them.

Have the property or work area marked for buried lines and do not dig in marked areas. Contact your local marking service or utility company to have the property marked (for example, in the United States, call 811 for the nationwide marking service).

## ⚠ DANGER

Rotating rod and bits can entangle loose clothing, hands, arms, legs, and feet, causing death or serious injury.

- Keep at least ten feet from rotating parts, unless you are operating the rod guide tool.
- Never use anything but the rod guide tool for starting the rod and boring bit.
- Keep extremities and other parts of your body or clothing away from rotating parts.
- Do not wear loose clothing or jewelry while operating or assisting with the boring unit.
- Always turn off the traction unit before changing accessories.

## ⚠ WARNING

When the engine is off, attachments in the raised position can gradually lower. Someone nearby may be pinned or injured by the attachment as it lowers.

Always lower the attachment lift each time you shut off the traction unit.

## ⚠ WARNING

If you do not fully seat the attachment locking pins in the attachment mount plate holes, the attachment could fall off of the traction unit severely injuring the operator or bystanders.

- Ensure that you fully seat the attachment locking pins through the holes in the attachment mount plate before lifting the attachment.
- Ensure that the attachment mount plate is free of any dirt or debris that may hinder the connection of the traction unit to the attachment.
- Refer to your traction unit *Operator's Manual* for detailed information on safely connecting an attachment to your traction unit.

## ⚠ WARNING

Lightning can cause severe injury or death. If lightning is seen or thunder is heard in the area, do not operate the machine; seek shelter.

## ⚠ CAUTION

Hydraulic couplers, hydraulic lines/valves, and hydraulic fluid may be hot and can burn you if you touch them.

- Wear gloves when operating the hydraulic couplers.
- Allow the traction unit to cool before touching hydraulic components.
- Do not touch hydraulic fluid spills.
- Do not service the attachment unless rod rotation is stopped, the auxiliary hydraulics lever is moved to neutral, and the engine of the traction unit is stopped.
- Never use bolts or pins in place of push button connectors.
- Always use 2 people to operate the attachment, one to operate the traction unit and the other to guide the boring unit with the guide tool.
- Always use the guide tool to align the boring unit.
- Never straddle or stand on the rod when the engine is running.

# Stability Ratings

To determine the degree of slope you can traverse with the attachment installed on a traction unit, find the stability rating for the hill position you want to travel in the appropriate table below, then find the degree of slope for the same rating and hill position in the Stability Data section of the traction unit *Operator's Manual*.



## ⚠ WARNING

Exceeding the maximum recommended slope can cause the traction unit to tip, crushing you or bystanders.

Do not drive the traction unit on a slope steeper than the maximum recommended slope, as determined in the following tables and the traction unit *Operator's Manual*.

**Important:** If you have a traction unit other than the TX, the bore drive head is rated for use without the counterweight. If you use the counterweight

with the boring unit, the traction unit will be less stable in the front and side uphill positions.

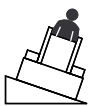
Orientation	Stability Rating
<b>Front Uphill</b> 	<b>D</b>
<b>Rear Uphill</b> 	<b>B</b>
<b>Side Uphill</b> 	<b>C</b>

# Safety and Instructional Decals



Safety decals and instructions are easily visible to the operator and are located near any area of potential danger. Replace any decal that is damaged or lost.



99-9945

1. Warning—read the *Operator's Manual*.
2. Entanglement hazard, shaft—keep bystander's a safe distance from the machine.
3. Explosion and electric shock hazard—do not dig in areas with buried gas or electrical lines; contact local power organizations before digging.

# Product Overview

## Specifications

**Note:** Specifications and design are subject to change without notice.

Width	24 inches (61 cm)
Length	22 inches (56 cm)
Height	25 inches (63.5 cm)
Weight	120 lb (54 Kg)
Boring diameter	1.25 to 3.5 inches (3.2 to 8.9 cm)

## Attachments/Accessories

A selection of Toro approved attachments and accessories are available for use with the machine to enhance and expand its capabilities. Contact your Authorized Service Dealer or Distributor or go to [www.Toro.com](http://www.Toro.com) for a list of all approved attachments and accessories.

# Operation

Refer to your traction unit *Operator's Manual* for more information on installing and removing attachments on your traction unit.

**Important:** Always use the traction unit to lift and move the attachment.

## Installing Accessories

Toro offers several different rods and bits for use with the attachment. Purchase accessories from your Toro dealer.

1. Stop the engine, wait for all moving parts to stop, and remove the key.
2. Slide the hex shaft of a rod, boring bit, or reamer into the socket. Align the hole in the socket with the push button connector (Figure 2).

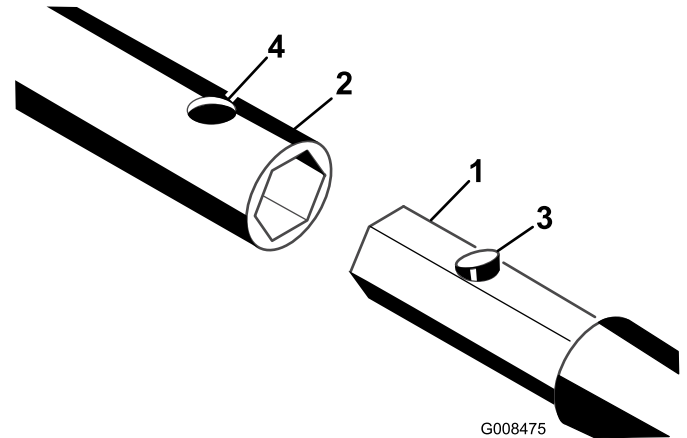

**Figure 2**

1. Accessory shaft
2. Socket
3. Push button connector
4. Hole

3. Press down the push button connector and push the shaft into the socket until the connector snaps into the hole in the socket (Figure 2).
4. Repeat steps 2 and 3.

## Removing an Accessory

1. Stop the engine, wait for all moving parts to stop, and remove the key.
2. Press the push button connector securing the accessory shaft in the socket and pull the accessory free of the socket.

# Boring a Hole

## Digging the Trenches

Before drilling under a walk or driveway, you must make an entrance and an exit trench on either side of the drilling area. Both trenches must be at least 6 inches wide and 18 inches deep. The entrance trench must be at least 7 feet long and the exit trench 3 to 6 feet long. The entrance trench should be perpendicular to the walk or driveway and the exit trench should be parallel to the walk or driveway. The exit trench should be centered across from the entrance trench (Figure 3).

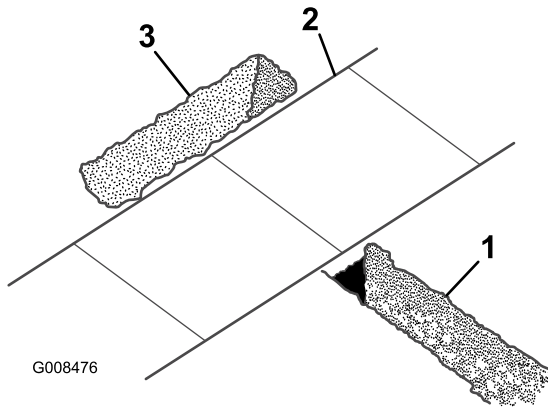

Figure 3

1. Entrance trench
2. Sidewalk
3. Exit trench

## Boring the Hole

**Important: Boring is a two person operation. Do not attempt to perform this operation by yourself.**

1. Position the traction unit with the drive head at the beginning of the trench and lower it to the appropriate depth.
2. Stop the engine and wait for all moving parts to stop.
3. Connect a rod and boring bit onto the drive head.
4. Connect the rod guide tool to the rod just behind the boring bit (Figure 4).

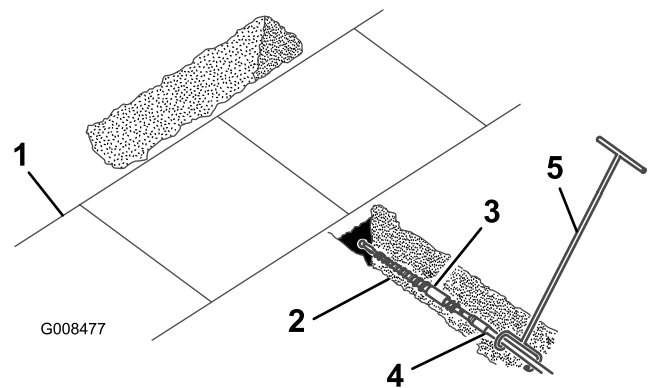

Figure 4

1. Sidewalk or driveway
2. Entrance trench
3. Boring bit
4. Rod
5. Rod guide tool

5. With the person guiding the boring bit positioned to the right of the trench (Figure 4), start the engine, move the pump selector valve to slow (turtle) (200 and 300 series traction units only), position the throttle to within the middle of the RPM range, and pull the auxiliary hydraulics lever rearward to start the forward rotation of the boring bit.
6. Slowly move the traction unit forward, while the person with the rod guide tool guides the boring bit into the soil (Figure 4).
7. Once the entire drill bit is in the soil, push the auxiliary hydraulics lever into neutral.
8. Stop the engine and wait for all moving parts to stop.
9. Check the grade of the rod.  
If the rod is not within the grade tolerances for the job being performed, start the engine and drive backward to pull the boring bit out of the soil, then repeat steps 5 through 9, making adjustments to correct the grade.
10. Remove the rod guide tool.
11. Start the engine and pull the auxiliary hydraulics lever rearward to start the boring bit.
12. Slowly move the traction unit forward as the boring bit digs into the soil.

**Important: Do not drive too fast, forcing the bit into the soil. Allow the bit to progress at its own rate. Never push or pull the bit through the soil when the drive head is not turning.**

13. When about 6 inches (15 cm) of rod are left showing in the entrance trench or when the boring bit completely enters and bores into the far side of the

exit trench, stop the traction unit, push the auxiliary hydraulics lever into neutral, and stop the engine.

14. If the boring bit has not yet entered the exit trench, complete the following:
  - A. Detach the rod from the drive head.
  - B. Start the engine and back up to the end of the entrance trench.
  - C. Stop engine and wait for all moving parts to stop.
  - D. Connect another rod and repeat steps 11 through 14.

## Reaming the Hole

1. With a shovel, carefully dig around the boring bit clearing it of soil until it can be removed (Figure 5).

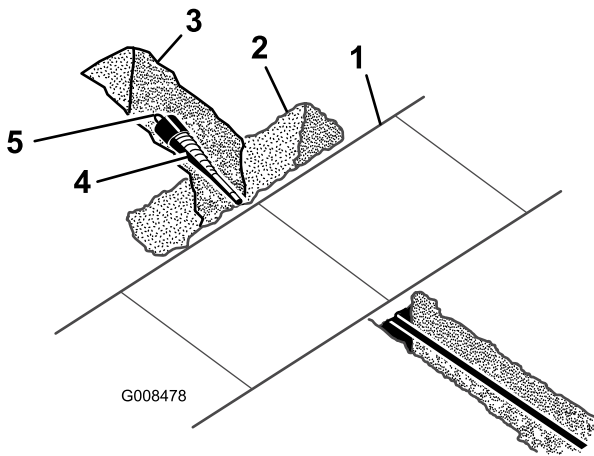

**Figure 5**

- |                               |           |
|-------------------------------|-----------|
| 1. Sidewalk or driveway       | 4. Reamer |
| 2. Exit trench                | 5. Swivel |
| 3. Shovel dug area around bit |           |

2. Remove the boring bit and attach the reamer (Figure 5).
3. Attach the cable or piping being installed to the swivel on the end of the reamer (Figure 5).
4. Start the engine and pull the auxiliary hydraulics lever rearward to start the reamer.
5. Slowly move the traction unit rearward as the reamer digs into the soil.

**Important: Do not drive too fast, forcing the reamer into the soil. Allow the reamer to progress at its own rate. Never push or pull the reamer through the soil when the drive head is not turning.**

6. When a rod coupling is about 6 inches (15 cm) into the entrance trench or when the reamer completely

enters the trench with about 6 inches (15 cm) of the cable or piping, stop the traction unit, pull the auxiliary hydraulics lever into neutral, and stop engine.

7. If the reamer has not yet entered the exit trench, complete the following:
  - A. Detach the rod from the drive head and rod still in the soil.
  - B. Start the engine and move to the front of the entrance trench.
  - C. Stop the engine and wait for all moving parts to stop.
  - D. Connect the drive head to the rod shaft in the soil.
  - E. Repeat steps 4 through 7.
8. With the reamer and cable/piping in the entrance trench, remove the cable or piping from the reamer.

# Storage

1. Before long term storage, wash the attachment with mild detergent and water to remove dirt and grime.
2. Check the condition of the hydraulic hoses. Replace any damaged hoses.
3. Ensure that all hydraulic couplers are connected together to prevent contamination of the hydraulic system.
4. Check and tighten all bolts, nuts, and screws. Repair or replace any damaged or worn part.
5. Paint all scratched or bare metal surfaces. Paint is available from your Authorized Service Dealer.
6. Store the attachment in a clean, dry garage or storage area. Cover it to protect it and keep it clean.



# Troubleshooting

Problem	Possible Cause	Corrective Action
The bore drive head will not rotate.	<ol style="list-style-type: none"><li data-bbox="586 212 1034 262">1. The hydraulic coupler is not completely connected</li><li data-bbox="586 279 964 304">2. A hydraulic coupler is damaged.</li><li data-bbox="586 338 1019 388">3. There is an obstruction in a hydraulic hose.</li><li data-bbox="586 401 906 426">4. A hydraulic hose is kinked.</li><li data-bbox="586 438 1027 489">5. The auxiliary valve on the traction unit is not opening.</li><li data-bbox="586 501 1027 527">6. A hydraulic motor is damaged or worn.</li></ol>	<ol style="list-style-type: none"><li data-bbox="1063 212 1430 237">1. Check and tighten all couplers.</li><li data-bbox="1063 279 1487 329">2. Check the couplers and replace any that are damaged.</li><li data-bbox="1063 338 1451 363">3. Find and remove the obstruction.</li><li data-bbox="1063 401 1365 426">4. Replace the kinked hose</li><li data-bbox="1063 438 1281 464">5. Repair the valve.</li><li data-bbox="1063 501 1398 527">6. Replace or repair the motor.</li></ol>

**Notes:**

**Notes:**



# Toro Compact Utility Equipment Warranty

A One-Year Limited Warranty

CUE Products

## Conditions and Products Covered

The Toro® Company and its affiliate, Toro Warranty Company, pursuant to an agreement between them, jointly warrant your Toro Compact Utility Equipment ("Product") to be free from defects in materials or workmanship. The following time periods apply from the date of purchase:

Products	Warranty Period
Loaders, Trenchers, Stump Grinders, Chippers, Log Splitters and Attachments Kohler Engines	1 year or 1000 operating hours, whichever occurs first
Kohler Engines	3 years
All other Engines	2 years

Where a warrantable condition exists, we will repair the Product at no cost to you including diagnosis, labor, and parts.

## Instructions for Obtaining Warranty Service

If you think that your Toro Product contains a defect in materials or workmanship, follow this procedure:

1. Contact any Authorized Toro Compact Utility Equipment (CUE) Service Dealer to arrange service at their dealership. To locate a dealer convenient to you, access our website at [www.Toro.com](http://www.Toro.com). You may also call our Toro Customer Care Department toll free at 888-865-5676 (U.S. customers) or 888-865-5691 (Canadian customers).
2. Bring the product and your proof of purchase (sales receipt) to the Service Dealer.
3. If for any reason you are dissatisfied with the Service Dealer's analysis or with the assistance provided, contact us at:

LCB Customer Care Department  
 Toro Warranty Company  
 8111 Lyndale Avenue South  
 Bloomington, MN 55420-1196  
 Toll Free: 888-865-5676 (U.S. customers)  
 Toll Free: 888-865-5691 (Canada customers)

## Owner Responsibilities

You must maintain your Toro Product by following the maintenance procedures described in the *Operator's Manual*. Such routine maintenance, whether performed by a dealer or by you, is at your expense. Parts scheduled for replacement as required maintenance ("Maintenance Parts"), are warranted for the period of time up to the scheduled replacement time for that part. Failure to perform required maintenance and adjustments can be grounds for disallowing a warranty claim.

## Items and Conditions Not Covered

Not all product failures or malfunctions that occur during the warranty period are defects in materials or workmanship. This express warranty does not cover the following:

- Product failures which result from the use of non-Toro replacement parts, or from installation and use of add-on, modified, or unapproved accessories
- Product failures which result from failure to perform required maintenance and/or adjustments
- Product failures which result from operating the Product in an abusive, negligent or reckless manner
- Parts subject to consumption through use unless found to be defective. Examples of parts which are consumed, or used up, during normal Product operation include, but are not limited to, teeth, tines, blades, spark plugs, tires, tracks, filters, chains, etc.
- Failures caused by outside influence. Items considered to be outside influence include, but are not limited to, weather, storage practices, contamination, use of unapproved coolants, lubricants, additives, or chemicals, etc.
- Normal "wear and tear" items. Normal "wear and tear" includes, but is not limited to, worn painted surfaces, scratched decals or windows, etc.
- Any component covered by a separate manufacturer's warranty
- Pickup and delivery charges

## General Conditions

Repair by an Authorized Toro Compact Utility Equipment (CUE) Service Dealer is your sole remedy under this warranty.

**Neither The Toro® Company nor Toro Warranty Company is liable for indirect, incidental or consequential damages in connection with the use of the Toro Products covered by this warranty, including any cost or expense of providing substitute equipment or service during reasonable periods of malfunction or non-use pending completion of repairs under this warranty. All implied warranties of merchantability and fitness for use are limited to the duration of this express warranty. Some states do not allow exclusions of incidental or consequential damages, or limitations on how long an implied warranty lasts, so the above exclusions and limitations may not apply to you.**

This warranty gives you specific legal rights, and you may also have other rights which vary from state to state.

Except for the engine warranty coverage and the Emissions warranty referenced below, if applicable, there is no other express warranty. The Emissions Control System on your Product may be covered by a separate warranty meeting requirements established by the U.S. Environmental Protection Agency (EPA) or the California Air Resources Board (CARB). The hour limitations set forth above do not apply to the Emissions Control System Warranty. Refer to the California Emission Control Warranty Statement supplied with your Product or contained in the engine manufacturer's documentation for details.

## Countries Other than the United States or Canada

Customers who have purchased Toro products exported from the United States or Canada should contact their Toro Distributor (Dealer) to obtain guarantee policies for your country, province, or state. If for any reason you are dissatisfied with your Distributor's service or have difficulty obtaining guarantee information, contact the Toro importer. If all other remedies fail, you may contact us at Toro Warranty Company.