



Count on it.

Operator's Manual

Auger Head and Universal Swivel Auger Head

for Compact Utility Loaders

Model No. 22805—Serial No. 310000001 and Up

Model No. 22806—Serial No. 310000001 and Up

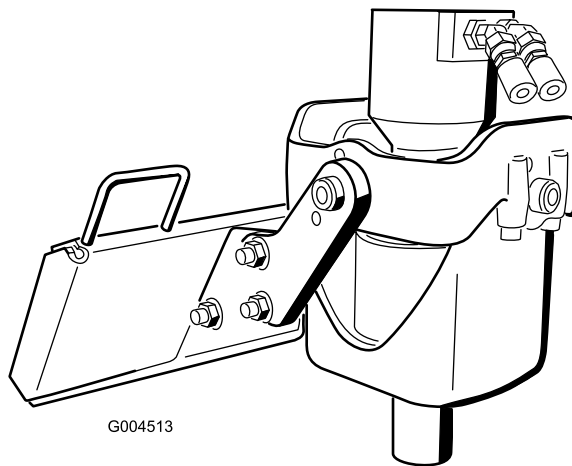

G004513

This product complies with all relevant European directives, for details please see the separate product specific Declaration of Conformity (DOC) sheet.

▲ DANGER

There may be buried power, gas, and/or telephone lines in the work area. Shock or explosion may occur if you dig into them.

Have the property or work area marked for buried lines and do not dig in marked areas. Contact your local marking service or utility company to have the property marked (for example, in the United States, call 811 for the nationwide marking service).

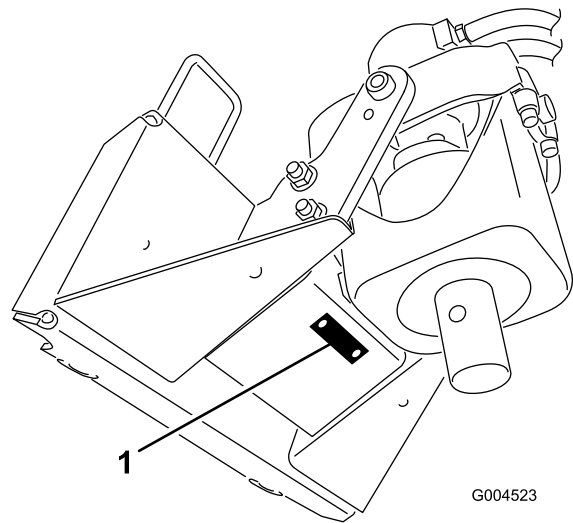

Figure 1

1. Model and serial number location

Model No. _____
Serial No. _____

Introduction

The machine is a hydraulically powered auger attachment for Toro compact utility loaders. It is designed to dig vertical holes in earth for the installation of posts, plants, and other construction and landscaping needs. It is not intended to drill holes in pavement, concrete, or ice.

Read this information carefully to learn how to operate and maintain your product properly and to avoid injury and product damage. You are responsible for operating the product properly and safely.

You may contact Toro directly at www.Toro.com for product and accessory information, help finding a dealer, or to register your product.

Whenever you need service, genuine Toro parts, or additional information, contact an Authorized Service Dealer or Toro Customer Service and have the model and serial numbers of your product ready. Figure 1 identifies the location of the model and serial numbers on the product. On augers and extensions, the model and serial number plate is located on the upper portion of the shaft. Write the numbers in the space provided.

This manual identifies potential hazards and has safety messages identified by the safety alert symbol (Figure 2), which signals a hazard that may cause serious injury or death if you do not follow the recommended precautions.



Figure 2

1. Safety alert symbol

This manual uses 2 other words to highlight information. **Important** calls attention to special mechanical information and **Note** emphasizes general information worthy of special attention.

Contents

- Introduction..... 2
- Safety 3
 - Stability Ratings..... 4
 - Safety and Instructional Decals 5
- Product Overview 5
 - Specifications 5
- Operation..... 6
 - Installing an Auger 6
 - Digging a Hole 7

Removing an Auger	8
Maintenance.....	9
Recommended Maintenance Schedule(s)	9
Greasing the Cradle Arm Pivot Points	9
Changing Planetary Gear Case Oil	9
Storage.....	10
Troubleshooting.....	11

Safety

Improper use or maintenance by the operator or owner can result in injury. To reduce the potential for injury, comply with these safety instructions and those in the traction unit *Operator’s Manual*. Always pay attention to the safety alert symbol, which means *Caution*, *Warning*, or *Danger*—personal safety instruction. Failure to comply with the instruction may result in personal injury or death.

▲ DANGER

Contact with a moving auger can cause entanglement, severe wounds, and/or death.

Keep all others at least 10 feet away from the auger during operation. Also, do not replace the supplied bolt which secures the auger to the drive head with a longer bolt as this may increase the chance for entanglement.

▲ DANGER

There may be buried power, gas, and/or telephone lines in the work area. Shock or explosion may occur if you dig into them.

Have the property or work area marked for buried lines and do not dig in marked areas. Contact your local marking service or utility company to have the property marked (for example, in the United States, call 811 for the nationwide marking service).

▲ WARNING

When the engine is off, attachments in the raised position can gradually lower. Someone nearby may be pinned or injured by the attachment as it lowers.

Always lower the attachment lift each time you shut off the traction unit.

▲ WARNING

When going up or down hill, the machine could overturn if the heavy end is toward the downhill side. Someone may be pinned or seriously injured by the machine if it overturns.

Operate up and down slopes with the heavy end of the machine uphill. An attached auger bit will make the front end heavy.

⚠ WARNING

Lightning can cause severe injury or death. If lightning is seen or thunder is heard in the area, do not operate the machine; seek shelter.

Stability Ratings

To determine the degree of slope you can traverse with the auger installed on a traction unit, find the stability rating for the hill position you want to travel in the appropriate table below, then find the degree of slope for the same rating and hill position in the Stability Data section of the traction unit *Operator's Manual*.



⚠ WARNING

Exceeding the maximum recommended slope can cause the traction unit to tip, crushing you or bystanders.

Do not drive the traction unit on a slope steeper than the maximum recommended slope, as determined in the following tables and the traction unit *Operator's Manual*.

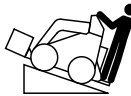

Stability with a 12 to 30 inch Auger

Important: If you have a traction unit other than a TX compact utility loader, use the counterweight on the traction unit when using the auger drive head with a large auger installed. Failure to use the counterweight will cause the traction unit to become unstable.

Orientation	Stability Rating
Front Uphill 	D
Rear Uphill 	D
Side Uphill 	C

Stability Without an Auger or with an Auger Smaller than 12 inches

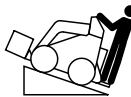
Important: If you have a traction unit other than a TX compact utility loader, do not use the counterweight on the traction unit when using the auger drive head without an auger or with an auger smaller than 12 inches. If you use the counterweight, the traction unit will be less stable in the front and side uphill positions.

Orientation	Stability Rating
Front Uphill 	D
Rear Uphill 	C
Side Uphill 	B

Safety and Instructional Decals



Safety decals and instructions are easily visible to the operator and are located near any area of potential danger. Replace any decal that is damaged or lost.

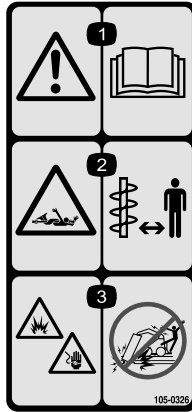

105-0326

1. Warning—read the *Operator's Manual*.
2. Entanglement hazard, auger—keep bystanders a safe distance from the auger.
3. Explosion and/or electric shock hazard—do not dig in areas with buried gas or power lines.

Product Overview

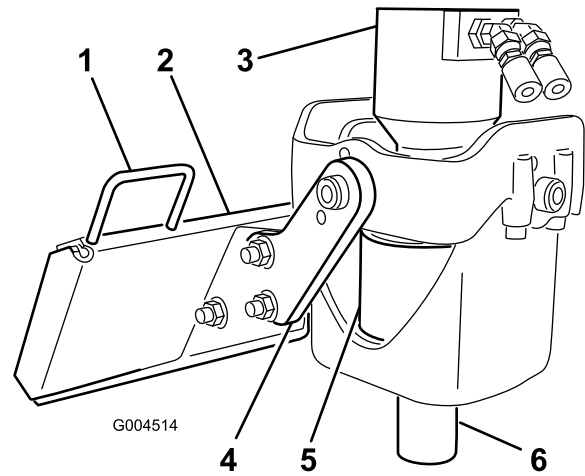

Figure 3

- | | |
|-------------------|----------------|
| 1. Hose guide | 4. Cradle arm |
| 2. Mounting plate | 5. Drive head |
| 3. Motor | 6. Drive shaft |

Specifications

Note: Specifications and design are subject to change without notice.

Model 22805	
Width	24.3 inches (62 cm)
Length	15.8 inches (40 cm)
Height	23.3 inches (59 cm)
Weight	182 lb (83 Kg)

Model 22806	
Width	24.3 inches (62 cm)
Length	16.5 inches (42 cm)
Height	23.4 inches (59 cm)
Weight	196 lb (89 Kg)

Operation

Refer to your traction unit *Operator's Manual* for more information on installing and removing attachments on your traction unit.

Note: Always use the traction unit to lift and move the attachment. To move an auger without the drive head, sling a strap over each end of the auger and hoist it to the desired location.

Installing an Auger

⚠ WARNING

The auger head swings freely in the cradle arms. Your hands or fingers could get pinched and severely injured or amputated if they are caught between the cradle arms and the swinging drive head.

Keep your hands and fingers away from the cradle arms.

1. If you are installing an auger on model 22806 drive head, position the drive head vertically, slide a bolt (1/2 x 2-1/2 inches) into the holes in the front cradle arms, and secure it lightly with a flange nut (1/2 inch) (Figure 4).

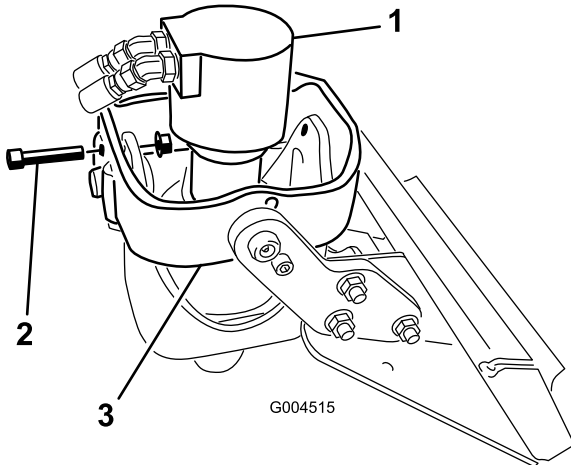

Figure 4

- | | |
|----------------------------|---------------------|
| 1. Drive head (front view) | 3. Front cradle arm |
| 2. Bolt | |

2. Raise the loader arms so the drive head clears the ground.
3. Stop the engine.
4. Manually rotate the auger drive head up, until you can slide a bolt (1/2 x 2-1/2 inches) into the hole in the cradle arm, securing the drive head.

Lightly secure the bolt with a flange nut (1/2 inch) (Figure 5).

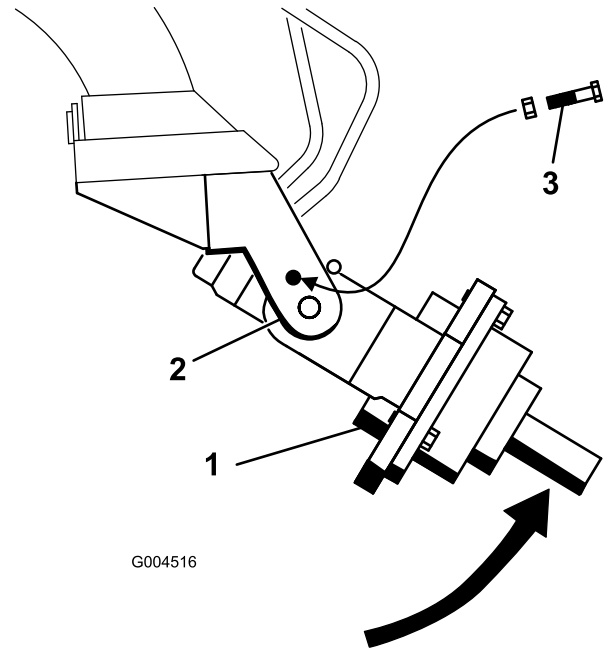

Figure 5

- | | |
|---------------|------------------------|
| 1. Drive head | 3. Bolt and flange nut |
| 2. Cradle arm | |

5. If using an extension with the auger, insert the end of the extension into the end of the auger and secure the auger to the extension with a bolt (7/8 x 4-1/2 inch) and nut (7/8 inch) (Figure 6).

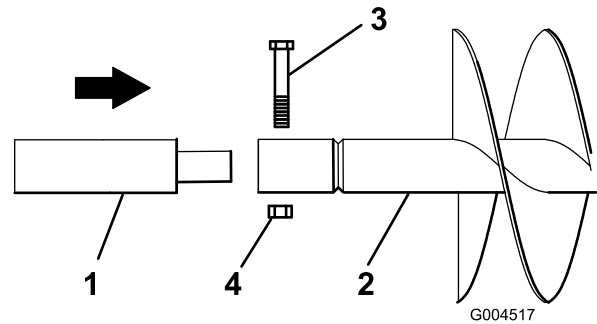

Figure 6

- | | |
|----------------|---------------------------|
| 1. Extension | 3. Bolt, 7/8 x 4-1/2 inch |
| 2. Auger shaft | 4. Nut, 7/8 inch |

6. Start the engine.
7. Maneuver the drive shaft into the end of the auger shaft or extension (if applicable) (Figure 7).

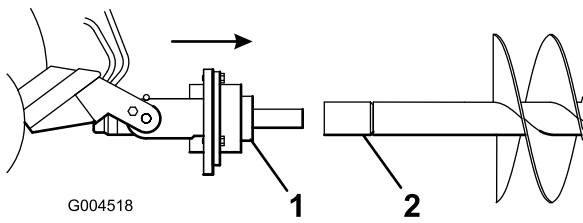

Figure 7

1. Drive head
2. Auger shaft

8. Stop the engine.
9. Secure the auger to the drive head with a bolt (7/8 x 4-1/2 inch) and nut (7/8 inch) (Figure 8).

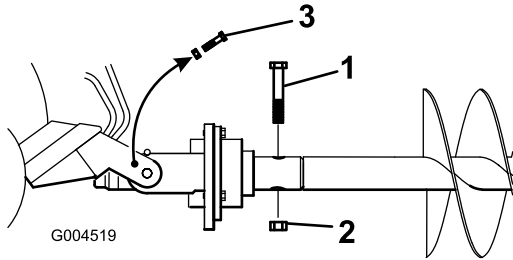

Figure 8

1. Bolt, 7/8 x 4-1/2 inches
2. Nut, 7/8 inch
3. Bolt(s) and nut(s)

10. Remove the bolts and nuts from the cradle arms that were installed in steps 1 (if applicable) and 4 (Figure 8).
11. Start the engine.
12. Raise the auger free of the ground (Figure 9).

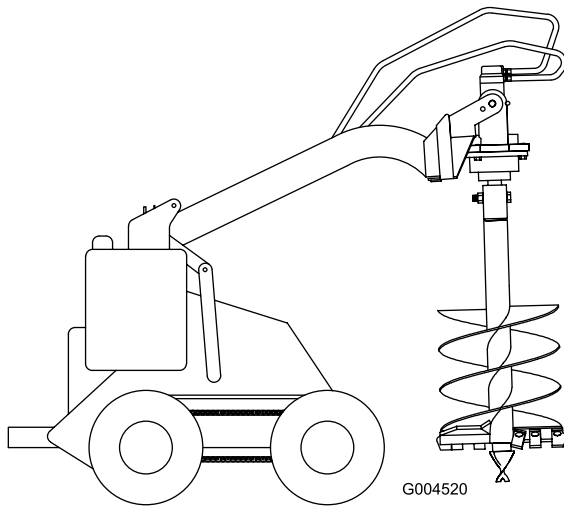

Figure 9

13. When the auger is vertical, tilt the attachment plate rearward, until the drive head contacts the attachment plate to stabilize the auger and keep it from swinging freely (Figure 9).

Digging a Hole

⚠ DANGER

There may be buried power, gas, and/or telephone lines in the work area. Shock or explosion may occur if you dig into them.

Have the property or work area marked for buried lines and do not dig in marked areas. Contact your local marking service or utility company to have the property marked (for example, in the United States, call 811 for the nationwide marking service).

Important: Before digging, ensure that the ground is free of any trash or debris.

Important: Do not use the auger unless the auger point and teeth are intact and in good condition.

1. Lower the auger to the soil at the site of the proposed hole.
2. Move the throttle lever to the Fast position.
3. If your traction unit has a speed selector lever, move it to the Slow position.
4. If your traction unit has a flow divider control, move it to the 10:00 o'clock position.
5. Pull the auxiliary hydraulics lever to the operator grip or reference bar to begin digging.
6. Lower the auger slowly as the soil is loosened. As you dig deeper, move the traction unit backward or forward as required to keep the auger vertical (Figure 10).

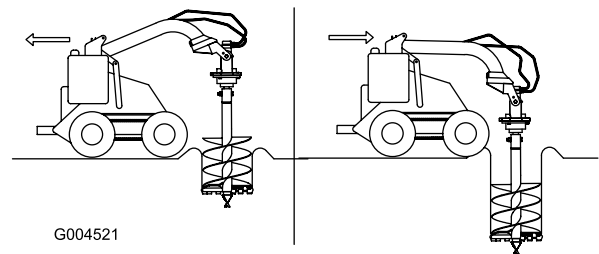

Figure 10

7. When the auger becomes full of soil, disengage the auger drive and lift the auger from the hole. Engage the auger drive to spin off the soil, then resume digging.

Note: Switching the auxiliary hydraulics lever rapidly from forward to reverse will help to shake off the soil.

⚠ DANGER

If you are using model 22806, excessive downward force may cause the bit to wobble uncontrollably which could tip the traction unit. You or bystanders could be pinned or seriously injured.

When using model 22806, do not use excessive downward pressure on the bit. Allow the bit to pull itself into the soil.

Removing an Auger

1. Raise the loader arms so the auger comes out of the hole.

Note: If you have a 24 inch extension installed between the drive head and the auger, it may be necessary to raise the auger as high as possible and then move the traction unit backward to pull the auger the rest of the way out of the hole.

2. Set the auger down in its storage location.
3. While lowering the arms, drive slowly backwards until the auger is horizontal.
4. Stop the engine.
5. Remove the bolt and nut securing the drive head to the auger or extension.
6. Start the engine and back the traction unit away from the auger.
7. If you used an extension, remove the bolt and nut securing it and pull it off of the auger.

Maintenance

Recommended Maintenance Schedule(s)

Maintenance Service Interval	Maintenance Procedure
After the first 50 hours	<ul style="list-style-type: none">• Change the planetary gear case oil.
Before each use or daily	<ul style="list-style-type: none">• Grease the cradle arm pivot points. (Grease all fittings immediately after every washing.)• Check the auger teeth and replace them if they are damaged or worn.
Every 1,000 hours	<ul style="list-style-type: none">• Change the planetary gear case oil.
Before storage	<ul style="list-style-type: none">• Check the auger teeth and replace them if they are damaged or worn.• Paint chipped surfaces.

⚠ CAUTION

If you leave the key in the ignition switch, someone could start the engine. Accidental starting of the engine could seriously injure you or other bystanders.

Remove the key from the ignition switch before you do any maintenance.

Greasing the Cradle Arm Pivot Points

Service Interval: Before each use or daily (Grease all fittings immediately after every washing.)

Grease Type: General-purpose grease

1. Stop the engine and remove the key.
2. Clean the grease fittings with a rag.
3. Connect a grease gun to each fitting.
4. Pump grease into the fittings until grease begins to ooze out of the bearings.
5. Wipe up any excess grease.

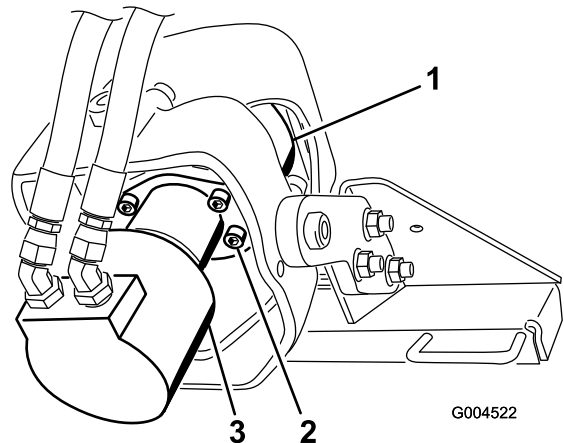

Figure 11

1. Planetary gear case
2. Bolts
3. Motor

Changing Planetary Gear Case Oil

Service Interval: After the first 50 hours
Every 1,000 hours

The planetary gear case requires 0.85 pints of a mild, extreme pressure lubricant, rated API-GL-5, number 80 or 90.

1. Support the drive head over an oil pan (Figure 11).

2. Remove the 4 bolts securing the motor and remove the motor, allowing all of the oil to drain into the pan.
3. When the oil is completely drained, turn the drive head so that the opening is facing the up.
4. Add 0.85 pints of a mild, extreme pressure lubricant, rated API-GL-5, number 80 or 90.
5. Replace the motor and secure it with the four bolts removed previously. Torque the bolts to 105 ft-lb (142 N-m)

Storage

1. Before long term storage, wash the attachment with mild detergent and water to remove dirt and grime.
2. Check and tighten all bolts, nuts, and screws. Repair or replace any damaged or worn part.
3. Ensure that all hydraulic couplers are connected together to prevent contamination of the hydraulic system.
4. Paint all scratched or bare metal surfaces. Paint is available from your Authorized Service Dealer.
5. Store the attachment in a clean, dry garage or storage area. Cover it to protect it and keep it clean.

Troubleshooting

Problem	Possible Cause	Corrective Action
The drive head does not operate.	<ol style="list-style-type: none">1. Hydraulic coupler not completely connected2. Defective hydraulic coupler3. An obstruction in a hydraulic hose4. Kinked hydraulic hose5. Contamination in the gearbox	<ol style="list-style-type: none">1. Check and tighten all couplers.2. Check couplers and replace any that are defective.3. Find and remove the obstruction.4. Replace the kinked hose5. Refer to your authorized service dealer.



Toro Compact Utility Equipment Warranty

A One-Year Limited Warranty

CUE Products

Conditions and Products Covered

The Toro® Company and its affiliate, Toro Warranty Company, pursuant to an agreement between them, jointly warrant your Toro Compact Utility Equipment ("Product") to be free from defects in materials or workmanship. The following time periods apply from the date of purchase:

Products	Warranty Period
Loaders, Trenchers and Attachments	1 year or 1000 operating hours, whichever occurs first
Kohler Engines	3 years
All other Engines	2 years

Where a warrantable condition exists, we will repair the Product at no cost to you including diagnosis, labor, and parts.

Instructions for Obtaining Warranty Service

If you think that your Toro Product contains a defect in materials or workmanship, follow this procedure:

1. Contact any Authorized Toro Compact Utility Equipment (CUE) Service Dealer to arrange service at their dealership. To locate a dealer convenient to you, access our website at www.Toro.com. You may also call our Toro Customer Care Department toll free at 888-865-5676 (U.S. customers) or 888-865-5691 (Canadian customers).
2. Bring the product and your proof of purchase (sales receipt) to the Service Dealer.
3. If for any reason you are dissatisfied with the Service Dealer's analysis or with the assistance provided, contact us at:

LCB Customer Care Department
Toro Warranty Company
8111 Lyndale Avenue South
Bloomington, MN 55420-1196
Toll Free: 888-865-5676 (U.S. customers)
Toll Free: 888-865-5691 (Canada customers)

Owner Responsibilities

You must maintain your Toro Product by following the maintenance procedures described in the *Operator's Manual*. Such routine maintenance, whether performed by a dealer or by you, is at your expense. Parts scheduled for replacement as required maintenance ("Maintenance Parts"), are warranted for the period of time up to the scheduled replacement time for that part. Failure to perform required maintenance and adjustments can be grounds for disallowing a warranty claim.

Items and Conditions Not Covered

Not all product failures or malfunctions that occur during the warranty period are defects in materials or workmanship. This express warranty does not cover the following:

- Product failures which result from the use of non-Toro replacement parts, or from installation and use of add-on, modified, or unapproved accessories
- Product failures which result from failure to perform required maintenance and/or adjustments
- Product failures which result from operating the Product in an abusive, negligent or reckless manner
- Parts subject to consumption through use unless found to be defective. Examples of parts which are consumed, or used up, during normal Product operation include, but are not limited to, digging teeth, tines, spark plugs, tires, tracks, filters, chains, etc.
- Failures caused by outside influence. Items considered to be outside influence include, but are not limited to, weather, storage practices, contamination, use of unapproved coolants, lubricants, additives, or chemicals, etc.
- Normal "wear and tear" items. Normal "wear and tear" includes, but is not limited to, worn painted surfaces, scratched decals or windows, etc.
- Any component covered by a separate manufacturer's warranty
- Pickup and delivery charges

General Conditions

Repair by an Authorized Toro Compact Utility Equipment (CUE) Service Dealer is your sole remedy under this warranty.

Neither The Toro® Company nor Toro Warranty Company is liable for indirect, incidental or consequential damages in connection with the use of the Toro Products covered by this warranty, including any cost or expense of providing substitute equipment or service during reasonable periods of malfunction or non-use pending completion of repairs under this warranty. All implied warranties of merchantability and fitness for use are limited to the duration of this express warranty. Some states do not allow exclusions of incidental or consequential damages, or limitations on how long an implied warranty lasts, so the above exclusions and limitations may not apply to you.

This warranty gives you specific legal rights, and you may also have other rights which vary from state to state.

Except for the engine warranty coverage and the Emissions warranty referenced below, if applicable, there is no other express warranty. The Emissions Control System on your Product may be covered by a separate warranty meeting requirements established by the U.S. Environmental Protection Agency (EPA) or the California Air Resources Board (CARB). The hour limitations set forth above do not apply to the Emissions Control System Warranty. Refer to the California Emission Control Warranty Statement supplied with your Product or contained in the engine manufacturer's documentation for details.

Countries Other than the United States or Canada

Customers who have purchased Toro products exported from the United States or Canada should contact their Toro Distributor (Dealer) to obtain guarantee policies for your country, province, or state. If for any reason you are dissatisfied with your Distributor's service or have difficulty obtaining guarantee information, contact the Toro importer. If all other remedies fail, you may contact us at Toro Warranty Company.