



Count on it.

Operator's Manual

Multi-Pro® 1250 Turf Sprayer

Model No. 41177—Serial No. 290001001 and Up

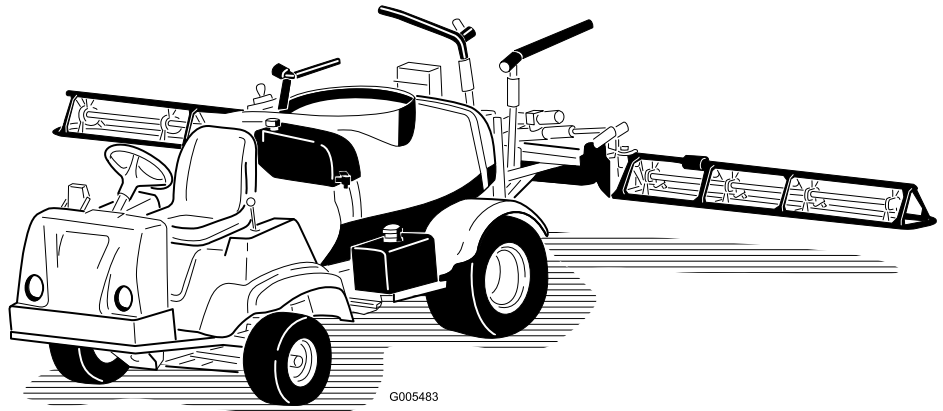

The Multi-Pro® turf sprayer is a dedicated turf spray application vehicle and is intended to be used by professional, hired operators in commercial applications. It is primarily designed for spraying on well-maintained lawns in parks, golf courses, sports fields, and on commercial grounds.

This product complies with all relevant European directives, for details please see the separate product specific Declaration of Conformity (DOC) sheet.

WARNING

CALIFORNIA Proposition 65 Warning

The engine exhaust from this product contains chemicals known to the State of California to cause cancer, birth defects, or other reproductive harm.

Important: This engine is not equipped with a spark arrester muffler. It is a violation of California Public Resource Code Section 4442 to use or operate the engine on any forest-covered, brush-covered, or grass-covered land. Other states or federal areas may have similar laws.

This spark ignition system complies with Canadian ICES-002.

The enclosed *Engine Owner's Manual* is supplied for information regarding the US Environmental Protection Agency (EPA) and the California Emission Control Regulation of emission systems, maintenance, and warranty. Replacements may be ordered through the engine manufacturer.

Introduction

Read this manual carefully to learn how to operate and maintain your product properly. The information in this manual can help you and others avoid injury and product damage. Although Toro designs and produces safe products, you are responsible for operating the product properly and safely. You may contact Toro directly at www.Toro.com for product and accessory information, help finding a dealer, or to register your product.

Whenever you need service, genuine Toro parts, or additional information, contact an Authorized Service Dealer or Toro Customer Service and have the model and serial numbers of your product ready. Figure 1 illustrates the location of the model and serial numbers on the product.

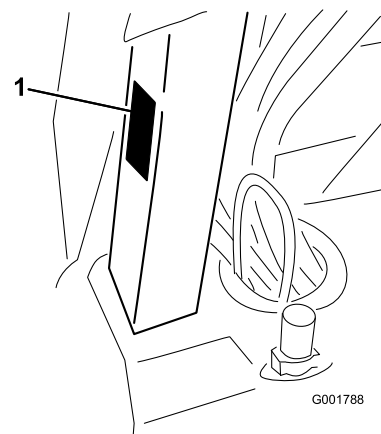

Figure 1

1. Location of the model and serial numbers

Model No. _____
Serial No. _____

This manual identifies potential hazards and has safety messages identified by the safety alert symbol (Figure 2), which signals a hazard that may cause serious injury or death if you do not follow the recommended precautions.



Figure 2

1. Safety alert symbol.

This manual uses two other words to highlight information. **Important** calls attention to special mechanical information and **Note** emphasizes general information worthy of special attention.

Contents

Introduction.....	2
Safety	4
Safe Operating Practices	4
Chemical Safety	4
Before Operating	5
While Operating.....	5
Maintenance.....	7
Sound Pressure.....	7
Hand-Arm Vibration.....	7
Whole Body Vibration.....	7
Safety and Instructional Decals	8
Setup.....	13

1 Installing the Anti-siphon Fill Receptacle	13	Checking the Brake Fluid.....	52
2 Installing the Spray Pro Monitor.....	14	Inspecting the Brakes	53
3 Checking the Boom Hinge Springs	15	Adjusting the Parking Brake.....	53
4 Adjusting the Booms to Level	16	Belt Maintenance.....	53
5 Completing the Setup: Learning more about your product.....	16	Servicing the Drive Belt	53
Product Overview	17	Adjusting the Steering Pump Belt.....	53
Controls	18	Hydraulic System Maintenance	54
Specifications	24	Checking the Transaxle/Hydraulic Fluid	54
Operation.....	25	Changing Transaxle/Hydraulic Fluid	54
Think Safety First.....	25	Replacing the Hydraulic Filter	55
Before Driving the Sprayer for the First Time	25	Spray System Maintenance.....	56
Pre-Starting Checks	26	Inspecting the Hoses	56
Driving the Sprayer.....	27	Pump Maintenance.....	56
New Sprayer Break-In	27	Adjusting the Boom Actuator	57
Operating the Sprayer.....	28	Emergency Manual Operation of the Boom Actuators	57
Filling the Fresh Water Tank	28	Inspecting the Nylon Pivot Bushings.....	58
Filling the Spray Tank	29	Cleaning	59
Operating the Booms	29	Cleaning the Flowmeter.....	59
Spraying	30	Cleaning the Suction Strainer	59
Spraying Tips	30	Storage.....	60
Cleaning the Sprayer.....	30	Troubleshooting.....	62
Calibrating the Spray Pro Monitor.....	33	Schematics	66
Calibrating the Boom Bypass Valves.....	35	Conditions and Products Covered.....	72
Pump	35	Instructions for Obtaining Warranty Service	72
Transporting the Sprayer	36	Owner Responsibilities.....	72
Towing the Sprayer.....	36	Items and Conditions Not Covered.....	72
Maintenance.....	37	Parts.....	72
Recommended Maintenance Schedule(s)	37	Note Regarding Deep Cycle Battery Warranty:	72
Daily Maintenance Checklist.....	38	Maintenance is at Owner's Expense.....	72
Notation for Areas of Concern	39	General Conditions	72
Premaintenance Procedures.....	40	Note regarding engine warranty:	72
Jacking the Sprayer	40	Countries Other than the United States or Canada	72
Lubrication.....	41		
Greasing the Sprayer.....	41		
Greasing the Boom Hinges.....	42		
Greasing the Actuator Rod Bearings	42		
Engine Maintenance.....	44		
Checking the Air Intake Screen	44		
Servicing the Air Cleaner	44		
Servicing the Engine Oil.....	45		
Changing the Spark Plugs	46		
Fuel System Maintenance	47		
Replacing the Fuel Filter	47		
Electrical System Maintenance.....	48		
Fuses.....	48		
Servicing the Battery.....	48		
Drive System Maintenance	50		
Maintaining the Primary Drive Clutch	50		
Inspecting the Wheels/Tires.....	51		
Adjusting the Front Wheel Toe-In.....	51		
Brake Maintenance.....	52		

Safety

Improper use or maintenance by the operator or owner can result in injury. To reduce the potential for injury, comply with these safety instructions and always pay attention to the safety alert symbol, which means CAUTION, WARNING, or DANGER—personal safety instruction. Failure to comply with the instruction may result in personal injury or death.

Supervisors, operators, and service persons should be familiar with the following standards and publications: (The material may be obtained from the address shown).

- Flammable and Combustible Liquids Code:
ANSI/NFPA 30
- National Fire Protection Association:
ANSI/NFPA #505; Powered Industrial Trucks
National Fire Prevention Association
Barrymarch Park Quincy, Massachusetts
02269 U.S.A.
- SAE J2258 Light Utility Vehicles
Society of Automotive Engineers
SAE World Headquarters 400 Commonwealth Drive
Warrendale, PA 15096-0001
- ANSI/UL 558; Internal Combustion
Engine Powered Industrial Trucks
American National Standards Institute, Inc.
1430 Broadway New York, New York 10018 U.S.A.
or Underwriters Laboratories 333 Pfingsten Road
Northbrook, Illinois 60062 U.S.A.

Safe Operating Practices

▲ WARNING

The sprayer is an off-highway vehicle only and is not designed, equipped, or manufactured for use on public streets, roads, or highways.

Supervisor's Responsibilities

- Make sure that operators are thoroughly trained and familiar with the *Operator's Manual*, Engine Manual, and all labels on the sprayer.
- Establish your own special procedures and work rules for unusual operating conditions (e.g. slopes too steep for sprayer operation).

Chemical Safety

▲ WARNING

Chemical substances used in the spray system may be hazardous and toxic to you, bystanders, animals, plants, soils or other property.

- **Carefully read and follow the chemical warning labels and Material Safety Data Sheets (MSDS) for all chemicals used and protect yourself according to the chemical manufacturer's recommendations. For example, use appropriate Personal Protective Equipment (PPE) including face and eye protection, gloves, or other equipment to guard against personal contact with the chemical.**
- **Keep in mind that there may be more than one chemical used and information on each should be assessed.**
- ***Refuse to operate or work on the sprayer if this information is not available!***
- **Before working on a spray system make sure the system has been triple rinsed and neutralized according to the recommendations of the chemical manufacturer(s).**
- **Verify there is an adequate supply of clean water and soap nearby, and immediately wash off any chemicals that contact you.**
- Obtain proper training before using or handling chemicals.
- Use the correct chemical for the job.
- Follow the chemical manufacturer's instructions for the safe application of the chemical.
- Handle chemicals in a well ventilated area.
- Wear goggles and other protective equipment as instructed by the chemical manufacturer. Ensure that as little skin as possible is exposed while using chemicals.
- Have clean water available especially when filling the spray tank.
- Do not eat, drink, or smoke while working with chemicals.
- Always wash your hands and other exposed areas as soon as possible after finishing the work.
- Properly dispose of unused chemicals and chemical containers as instructed by the chemical manufacturer and your local codes.
- Chemicals and fumes in the tanks are dangerous; never enter the tank or place your head over or in the opening.

Before Operating

- Operate the machine only after reading and understanding the contents of this manual.
- **Never** allow children to operate the sprayer.
- **Never** allow other adults to operate the sprayer without first reading and understanding the *Operator's Manual*. Only trained and authorized persons should operate this sprayer. Make sure that all operators are physically and mentally capable of operating the sprayer.
- This sprayer is designed to carry **only you**, the operator. **Never** carry any passengers on the sprayer.
- **Never** operate the sprayer when under the influence of drugs or alcohol. Even prescription drugs and cold medicines can cause drowsiness.
- Do not drive the sprayer when you are tired. Be sure to take occasional breaks. It is very important that you stay alert at all times.
- Become familiar with the controls and know how to stop the engine quickly.
- Keep all shields, safety devices, and decals in place. If a shield, safety device, or decal is malfunctioning, illegible, or damaged, repair or replace it before operating the machine.
- Always wear substantial shoes. Do not operate the machine while wearing sandals, tennis shoes, or sneakers. Do not wear loose fitting clothing or jewelry which could get caught in moving parts and cause personal injury.
- Wearing safety glasses, safety shoes, long pants, and a helmet is advisable and required by some local safety and insurance regulations.
- Avoid driving when it is dark, especially in unfamiliar areas. If you must drive when it is dark, be sure to drive cautiously, use the headlights, and even consider adding additional lights.
- Be extremely careful when operating around people. Always be aware of where bystanders might be and keep them away from the work area.
- Before operating the sprayer, always check the designated areas of the sprayer that are stated in the Pre-Starting Checks in the Operation section. If the machine does not function correctly or is damaged in any way, do **not** use the sprayer. Make sure that the problem is corrected before the sprayer or attachment is operated.
- Ensure that all fluid line connectors are tight and all hoses are in good condition before applying pressure to the system.
- Since gasoline is highly flammable, handle it carefully.

- Use an approved gasoline container.
- Do not remove the cap from the fuel tank when the engine is hot or running.
- Do not smoke while handling gasoline.
- Fill the fuel tank outdoors, and fill it to about 1 inch (25 mm) below the top of the tank (the bottom of the filler neck). Do not overfill it.
- Wipe up any spilled gasoline.

While Operating

▲ WARNING

Engine exhaust contains carbon monoxide, which is an odorless, deadly poison that can kill you.

Do not run engine indoors or in an enclosed area.

- The operator should remain seated whenever the sprayer is in motion. The operator should keep both hands on the steering wheel whenever possible. Keep your arms and legs within the sprayer body at all times.
- Always watch out for and avoid low overhangs such as tree limbs, door jambs, and overhead walkways. Make sure there is enough room over head to easily clear the sprayer and your head.
- Failure to operate the sprayer safely may result in an accident, tip over of the sprayer, and serious injury or death. Drive carefully. To prevent tipping or loss of control:
 - Use extreme caution, reduce speed, and maintain a safe distance around sand traps, ditches, creeks, ramps, unfamiliar areas, or any areas that have abrupt changes in ground conditions or elevation.
 - Watch for holes or other hidden hazards.
 - Use extra caution when operating the sprayer on wet surfaces, in adverse weather conditions, at higher speeds, or with a full load. Stopping time and distance will increase with a full load.
 - Avoid sudden stops and starts. Do not go from reverse to forward or forward to reverse without first coming to a complete stop.
 - Slow down before turning. Do not attempt sharp turns or abrupt maneuvers or other unsafe driving actions that may cause a loss of sprayer control.
 - Before backing up, look to the rear and ensure that no one is behind you. Back up slowly.
 - Watch out for traffic when you are near or crossing roads. Always yield the right of way

to pedestrians and other vehicles. This sprayer is **not** designed for use on streets or highways. Always signal your turns or stop early enough so that other people know what you plan to do. Obey all traffic rules and regulations.

- The electrical and exhaust systems of the sprayer can produce sparks capable of igniting explosive materials. Never operate the sprayer in or near an area where there is dust or fumes in the air which are explosive.
 - If you are ever unsure about safe operation, **stop work** and ask your supervisor.
 - Do not touch the engine or muffler while the engine is running or soon after it has stopped. These areas may be hot enough to cause burns.
 - If the machine ever vibrates abnormally, stop immediately, wait for all motion to stop, and inspect the sprayer for damage. Repair all damage before resuming operation.
 - Before getting off of the seat:
 1. Stop the movement of the machine.
 2. Place the range selector in Neutral and set the parking brake.
 3. Turn the ignition key to Off.
 4. Remove the ignition key.
- Important: Do not park the machine on an incline.**
- Lightning can cause severe injury or death. If lightning is seen or thunder is heard in the area, do not operate the machine; seek shelter.

Braking

- Slow down before you approach an obstacle. This gives you extra time to stop or turn away. Hitting an obstacle can damage the sprayer and its contents. More important, it can injure you.
- Gross Vehicle Weight (GVW) has a major impact on your ability to stop and/or turn. Heavy loads and attachments make a sprayer harder to stop or turn. The heavier the load, the longer it takes to stop.
- Turf and pavement are much more slippery when they are wet. It can take 2 to 4 times as long to stop on wet surfaces as on dry surfaces. If you drive through standing water deep enough to get the brakes wet, they will not work well until they are dry. After driving through water, you should test the brakes to make sure they work properly. If they do not, drive slowly while putting light pressure on the brake pedal. This will dry the brakes out.

Operating on Hills and Rough Terrain

Operating the sprayer on a hill may cause tipping or rolling of the sprayer, or the engine may stall and you could lose headway on the hill. This could result in personal injury.

- Do not accelerate quickly or slam on the brakes when backing down a hill, especially with a load.
- Never drive across a steep hill; always drive straight up or down or go around the hill.
- If the engine stalls or you begin to lose headway while climbing a hill, gradually apply the brakes and slowly back straight down the hill.
- Turning while traveling up or down hills can be dangerous. If you have to turn while on a hill, do it slowly and cautiously. Never make sharp or fast turns.
- Heavy loads affect stability. Reduce the weight of the load and your speed when operating on hills.
- Avoid stopping on hills, especially with a load. Stopping while going down a hill will take longer than stopping on level ground. If the sprayer must be stopped, avoid sudden speed changes, which may initiate tipping or rolling of the sprayer. Do not slam on the brakes when rolling backward, as this may cause the sprayer to overturn.
- The Toro Company strongly recommends installing the optional ROPS Kit when operating on hilly terrain. If you install a ROPS, always wear the seat belt when driving the sprayer.
- Reduce speed and load when operating on rough terrain, uneven ground, and near curbs, holes, and other sudden changes in terrain. Loads may shift, causing the sprayer to become unstable.

▲ WARNING

Sudden changes in terrain may cause abrupt steering wheel movement, possibly resulting in hand and arm injuries.

- Reduce your speed when operating on rough terrain and near curbs.
- Grip the steering wheel loosely around the perimeter. Keep your hands clear of the steering wheel spokes.

Loading

The weight of the cargo can change the sprayer center of gravity and sprayer handling. To avoid loss of control and personal injury, follow these guidelines:

- Reduce the weight of the load when operating on hills and rough terrain to avoid tipping or overturning of the sprayer.
- Liquid loads can shift. This shifting happens most often while turning, going up or down hills, suddenly changing speeds, or while driving over rough surfaces. Shifting loads can cause the sprayer to tip over.
- When operating with a heavy load, reduce your speed and allow for sufficient braking distance. Do not suddenly apply the brakes. Use extra caution on slopes.
- Be aware that heavy loads increase your stopping distance and reduce your ability to turn quickly without tipping over.

Maintenance

- Only permit qualified and authorized personnel to maintain, repair, adjust, or inspect the sprayer.
- Before servicing or making adjustments to the machine, stop the engine, set the parking brake, and remove the key from the ignition to prevent someone from accidentally starting the engine.
- To make sure that the entire machine is in good condition, keep all nuts, bolts, and screws properly tightened.
- To reduce the potential for fire, keep the engine area free of excessive grease, grass, leaves, and accumulation of dirt.
- Never use an open flame to check the level or leakage of fuel or battery electrolyte.
- If the engine must be running to perform a maintenance adjustment, keep your hands, feet, clothing, and any parts of your body away from the engine and any moving parts. Keep everyone away.
- Do not use open pans of fuel or flammable cleaning fluids when cleaning parts.
- **Do not adjust** the ground speed governor. To ensure safety and accuracy, have an Authorized Toro Distributor check the ground speed.
- Keep your body and hands away from pin hole leaks or nozzles that eject high pressure fluid. Use cardboard or paper to find leaks. Fluid escaping under pressure can penetrate skin and cause injury requiring surgery within a few hours by a qualified surgeon or gangrene may result.
- If major repairs are ever needed or assistance is required, contact an Authorized Toro Distributor.
- To be sure of optimum performance and safety, always purchase genuine Toro replacement parts and

accessories. Replacement parts and accessories made by other manufacturers could be dangerous. Altering this sprayer in any manner that may affect sprayer operation, performance, durability, or its use, may result in injury or death. Such use could void the product warranty.

Sound Pressure

This unit has a sound pressure level at the operator's ear of 82 dBA, which includes an Uncertainty Value (K) of 1 dBA.

Sound pressure level was determined according to the procedures outlined in ISO 11094.

Hand-Arm Vibration

Measured vibration level for right hand = 1.11 m/s²

Measured vibration level for left hand = 1.25 m/s²

Uncertainty Value (K) = 0.5 m/s²

Measured values were determined according to the procedures outlined in EN 1032.

Whole Body Vibration

Measured vibration level = 0.092 m/s²

Uncertainty Value (K) = 0.5 m/s²

Measured values were determined according to the procedures outlined in EN 1032.

Safety and Instructional Decals



Safety decals and instructions are easily visible to the operator and are located near any area of potential danger. Replace any decal that is damaged or lost.

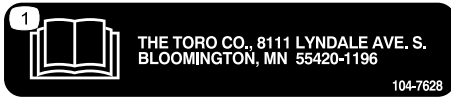

104-7628

1. Read the *Operator's Manual*.



100-8386

1. Fuel
2. Empty
3. Half-full
4. Full

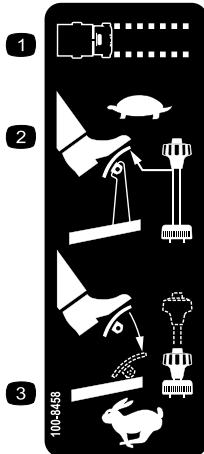

100-8458

1. Machine speed
2. To set the machine to a slow speed, reduce pressure on the accelerator and pull up on the speed limiter.
3. To set the machine to a fast speed, press the accelerator pedal and push down on the speed limiter.



117-2718



114-9576

1. Pinch point, hand—keep hand away from hinge.

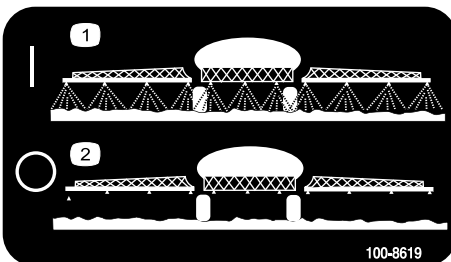

100-8619

1. Spray on
2. Spray off

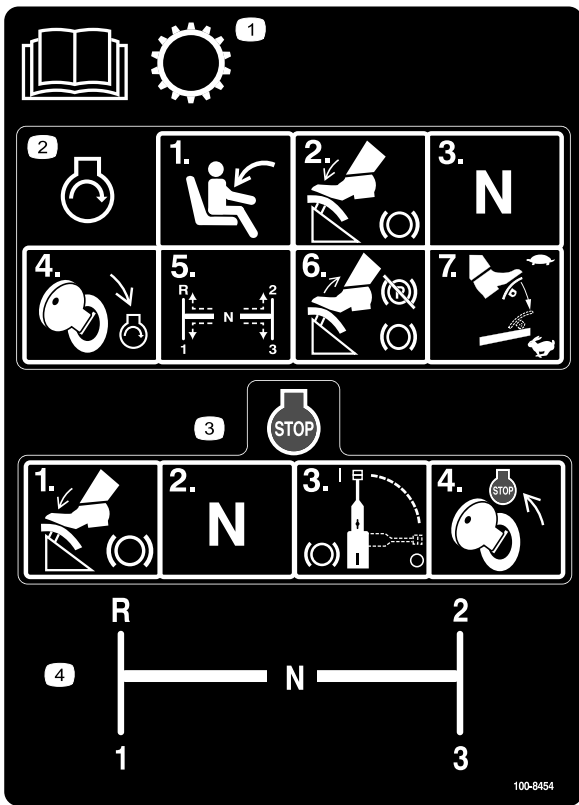

100-8454

1. Read the *Operator's Manual* for information on the transmission.
2. To start the engine, sit on the operator's seat, press the brake, set the range selector to Neutral, turn the ignition key to Engine-start, set the range selector to the desired gear, release the brake and parking brake, and press the accelerator pedal to the desired speed.
3. To stop the engine, press the brake, set the range selector to Neutral, set the parking brake, and turn the ignition key to Engine-stop.
4. Range selector gear pattern

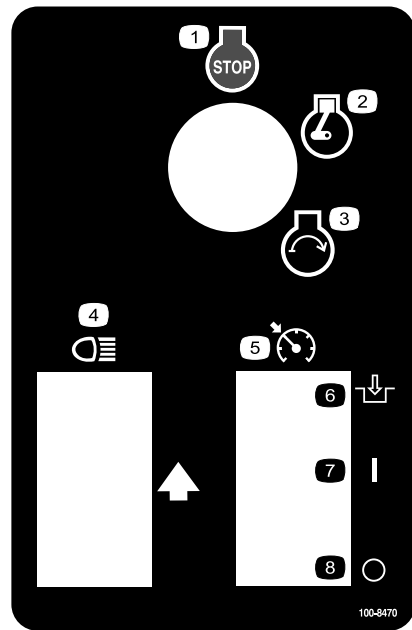

100-8470

- | | |
|-----------------|------------------------------|
| 1. Engine—stop | 5. Neutral engine speed lock |
| 2. Engine—run | 6. Engage |
| 3. Engine—start | 7. On |
| 4. Headlights | 8. Off |

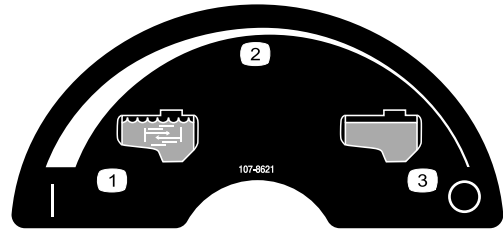

107-8621

- | | |
|--------------------------------|------------------|
| 1. Agitation on | 3. Agitation off |
| 2. Continuous variable setting | |

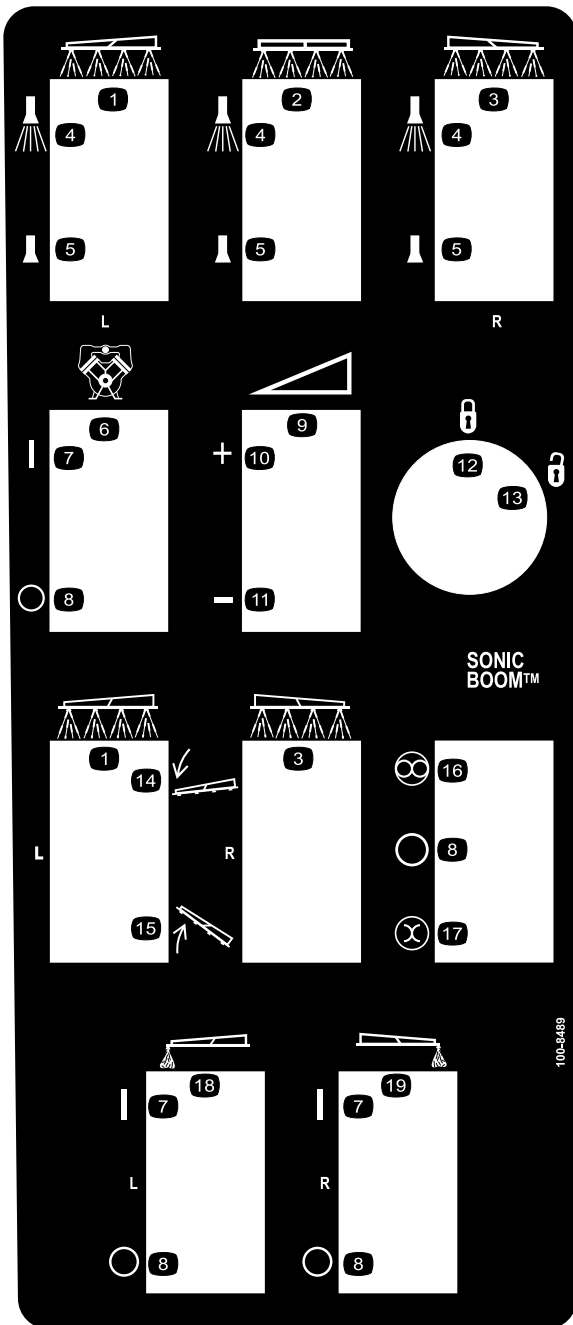

100-8489

- | | |
|--|----------------------------|
| 1. Left boom | 11. Decrease |
| 2. Center boom | 12. Locked |
| 3. Right boom | 13. Unlocked |
| 4. Spray on | 14. Lower the boom. |
| 5. Spray off | 15. Raise the boom. |
| 6. Pump | 16. Automatic |
| 7. On | 17. Manual |
| 8. Off | 18. Left boom foam marker |
| 9. Continuous variable setting, spray pressure | 19. Right boom foam marker |
| 10. Increase | |



106-5016

1. Warning—read the *Operator's Manual*.
2. Electric shock hazard, overhead power lines—stay away from overhead power lines.
3. Crushing hazard, boom—keep bystanders a safe distance from the machine.

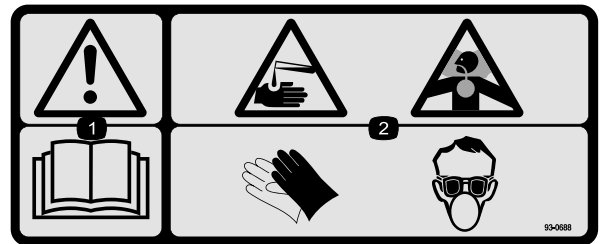

93-0688

1. Warning—read the *Operator's Manual*.
2. Caustic liquid/chemical burn and toxic gas inhalation hazards—wear hand, skin, eye, and respiratory protection.

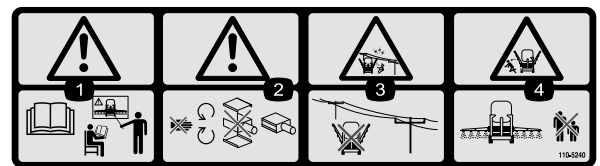

110-5240

1. Warning—read the *Operator's Manual* and receive training before operating.
2. Warning—stay away from moving parts, do not operate with covers removed.
3. Electric shock hazard, overhead power lines—stay away from overhead power lines.
4. Crushing hazard, boom—keep bystanders a safe distance from the machine.



110-5143

1. Warning—read the *Operator's Manual*.
2. Tipping Hazard—drive slowly over rough terrain and when turning.
3. Falling and arm/leg injury hazards—do not carry passengers and keep arms and legs inside of the vehicle at all times.
4. To stop the engine, press the brake, move the range selector to Neutral, set the parking brake, release the brake pedal, turn the ignition key to Engine-stop, and remove the key.

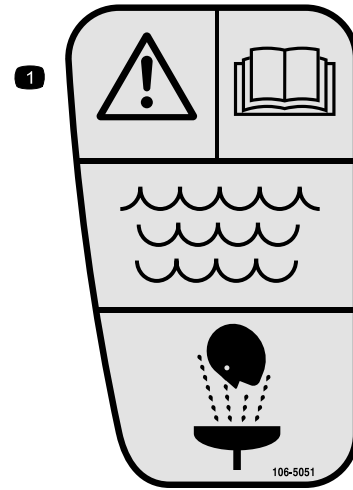

106-5051

1. Warning—read the *Operator's Manual*; use fresh, clean water for first-aid washing.

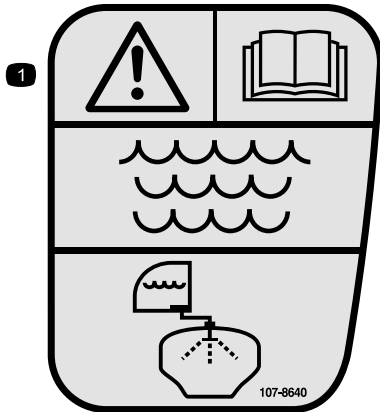

107-8640

1. Warning—read the *Operator's Manual*; use fresh, clean water for rinsing the tank.

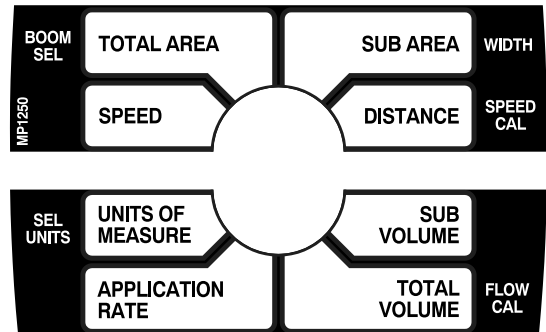

108-3307

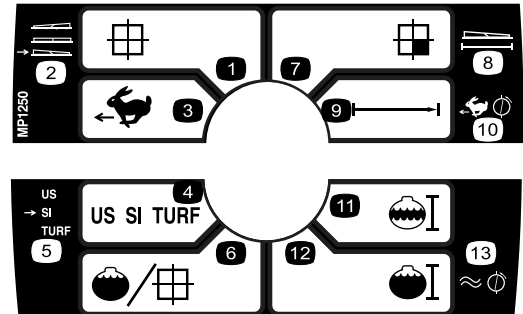

108-3309

- | | |
|---------------------|---------------------------|
| 1. Total area | 8. Width |
| 2. Boom select | 9. Distance |
| 3. Speed | 10. Speed calibration |
| 4. Units of measure | 11. Sub volume |
| 5. Select units | 12. Total volume |
| 6. Application rate | 13. Flowmeter calibration |
| 7. Sub area | |



106-1355

1. Warning—do not enter the tank.

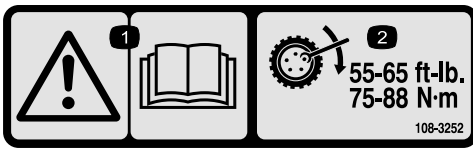

108-3252

1. Warning—read the *Operator's Manual*.
2. Torque lug nuts to 55-65 ft-lb (75-88 N·m).

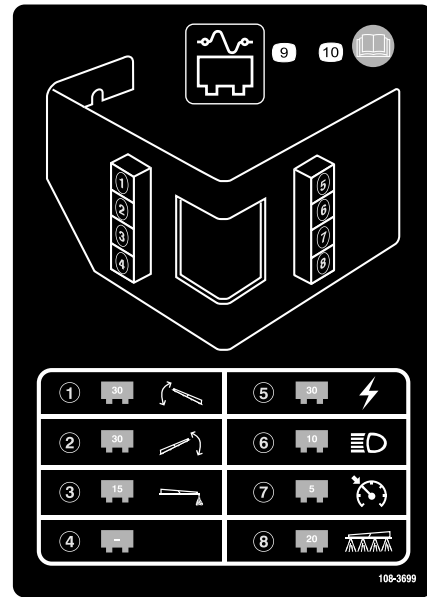

108-3699

1. 30 amp fuse, left boom actuator
2. 30 amp fuse, right boom actuator
3. 15 amp fuse, foam marker
4. Empty
5. 30 amp fuse, power
6. 10 amp fuse, headlights actuator
7. 5 amp fuse, cruise control actuator
8. 20 amp fuse, spray system
9. Fuse panel
10. Read the *Operator's Manual* for more information.

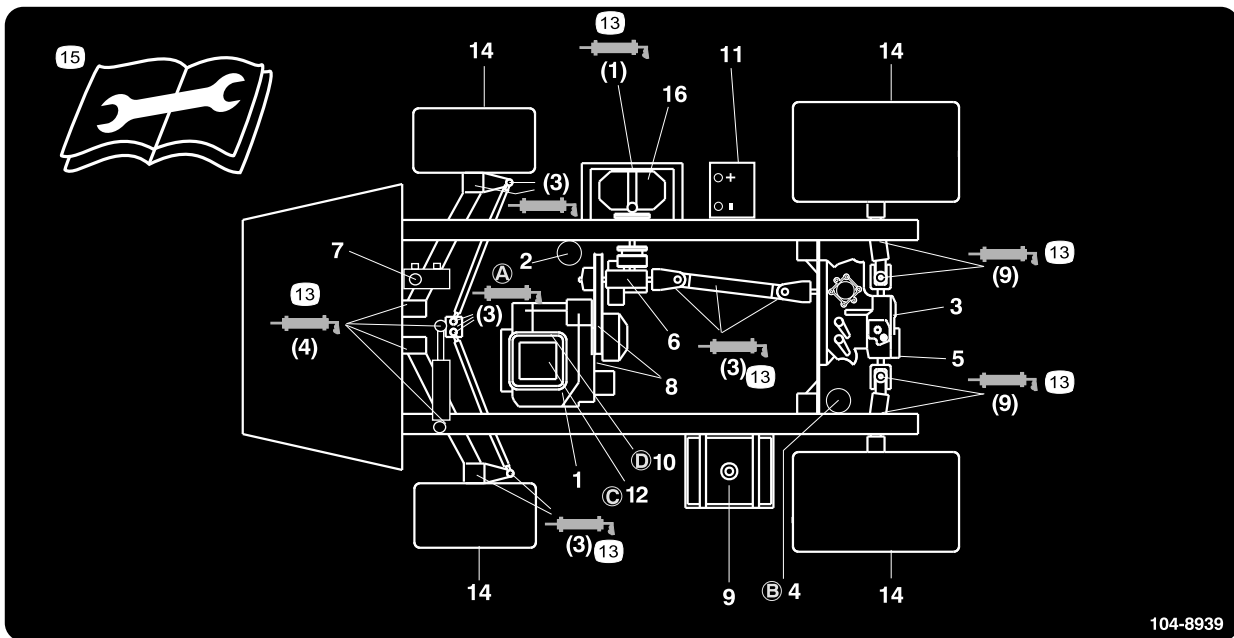

104-8939

- | | | | |
|---|------------------------------|------------------------|---|
| 1. Engine oil level (dipstick) | 5. Hydraulic strainer | 9. Fuel, unleaded only | 13. Grease |
| 2. Engine oil filter | 6. Gear box fluid level | 10. Fuel filter | 14. Tire pressure |
| 3. Transaxle/hydraulic fluid level (dipstick) | 7. Brake fluid | 11. Battery | 15. Read the instructions before servicing or performing maintenance. |
| 4. Transaxle hydraulic filter | 8. Belts, steering and drive | 12. Air cleaner | 16. Pump |

Setup

Loose Parts

Use the chart below to verify that all parts have been shipped.

Procedure	Description	Qty.	Use
1	90 degree fitting	1	Install the anti-siphon fill receptacle.
	Quick coupler	1	
	Hose adapter	1	
	Fill receptacle bracket	1	
	Flange-head bolt, 5/16 x 3/4 inch	1	
	Anti-siphon hose	1	
2	Spray Pro Monitor	1	Install the Spray-Pro monitor.
	Spray Pro Decal	1	
	Bracket	1	
	Flange-head bolt, 3/4 inch	2	
	Flange nut, 1/4 inch	2	
	Knob	2	
	Washer	2	
	Carriage bolt	2	
3	No parts required	–	Check the boom hinge springs.
4	No parts required	–	Adjust the booms to level.
5	Ignition key	1	Read the manuals and view the training material before operating the machine.
	Operator's Manual	1	
	Engine Operator's Manual	1	
	Parts Catalog	1	
	Operator Training Material	1	
	Registration Card	1	
	Pre-delivery Inspection Sheet	1	

Note: Determine the left and right sides of the machine from the normal operating position.

1

Installing the Anti-siphon Fill Receptacle

Parts needed for this procedure:

1	90 degree fitting
1	Quick coupler
1	Hose adapter
1	Fill receptacle bracket
1	Flange-head bolt, 5/16 x 3/4 inch
1	Anti-siphon hose

Procedure

1. Place the fill receptacle bracket over the threaded hole in the tank and secure it with a flange-head bolt (5/16 x 3/4 inch) (Figure 3).

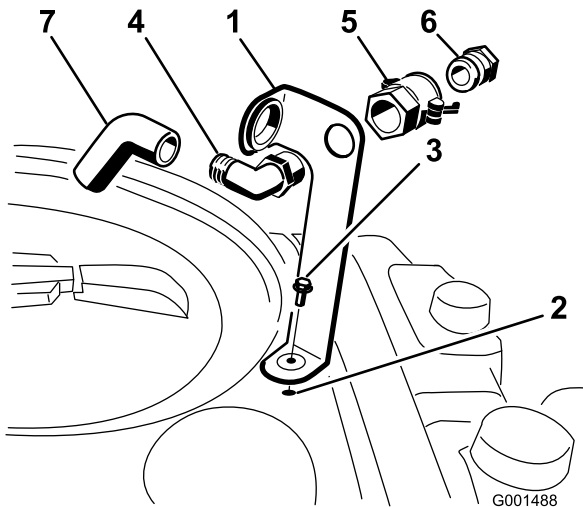

Figure 3

- | | |
|---------------------------------|---------------------|
| 1. Fill receptacle bracket | 5. Quick coupler |
| 2. Threaded hole in the tank | 6. Hose adapter |
| 3. Flange bolt, 5/16 x 3/4 inch | 7. Anti-siphon hose |
| 4. 90 degree elbow fitting | |

2. Place the threaded end of the 90 degree elbow fitting through the bracket and thread the quick coupler onto it, securing it to the bracket (Figure 3).

Note: Install the fitting with the open end pointing toward the large opening in the bracket and toward the tank opening so the water will arc into the tank when you fill it.

3. Install the hose adapter into the quick coupler (Figure 3).

4. Lock the adapter into place by swinging the levers toward the adapter and then secure them with the hairpin cotters (Figure 3).
5. Install the anti-siphon hose through the large opening on the bracket and onto the barbed end of the 90 degree elbow fitting (Figure 3).

Important: Do not lengthen the hose to allow contact with the tank fluids.

2

Installing the Spray Pro Monitor

Parts needed for this procedure:

1	Spray Pro Monitor
1	Spray Pro Decal
1	Bracket
2	Flange-head bolt, 3/4 inch
2	Flange nut, 1/4 inch
2	Knob
2	Washer
2	Carriage bolt

Procedure

1. Install the Spray Pro Decal to the monitor (Figure 4).

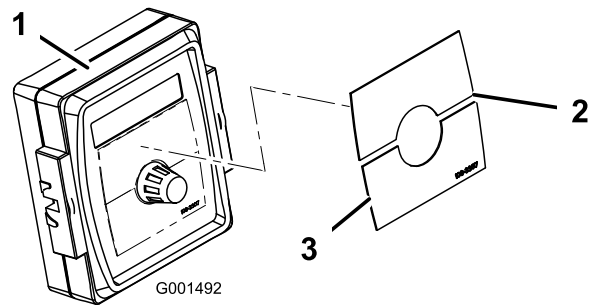

Figure 4

- | | |
|----------------------|----------------------|
| 1. Spray pro monitor | 3. Decal, Lower half |
| 2. Decal, Upper half | |

Note: Be sure to orient the decal as shown in Figure 20.

2. Install the monitor bracket on the dash (Figure 5) using 2 flange-head bolts (1/4 x 3/4 inch) and 2 flange nuts (1/4 inch).

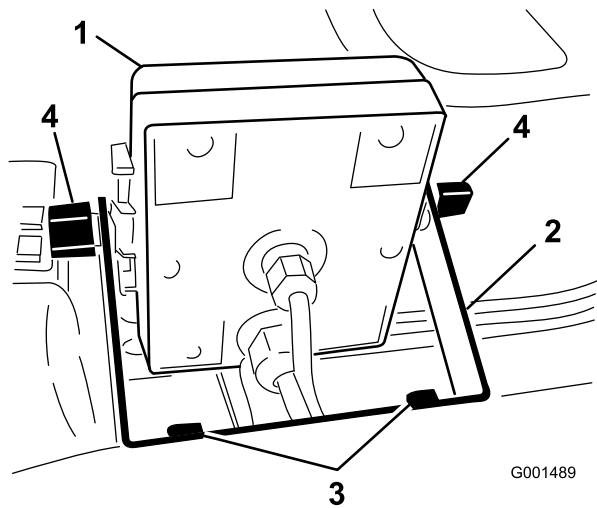

Figure 5

- | | |
|----------------------|--------------------------------------|
| 1. Spray Pro monitor | 3. Flange-head bolts, 1/4 x 3/4 inch |
| 2. Bracket | 4. Knob |

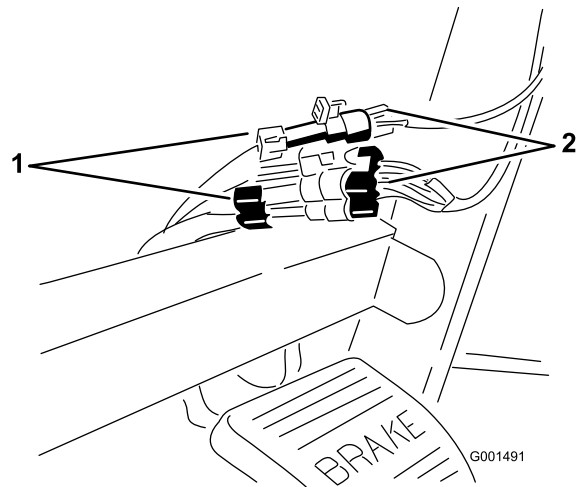

Figure 7

- | | |
|--------------------------------|--------------------------------|
| 1. Connectors from the sprayer | 2. Connectors from the monitor |
|--------------------------------|--------------------------------|

- Loosely install the 2 carriage bolts, rubber washers, and knobs on the bracket as illustrated in Figure Figure 5 and Figure 6.

Note: Install the carriage bolts and rubber washers inside of the bracket and the knobs on the outside.

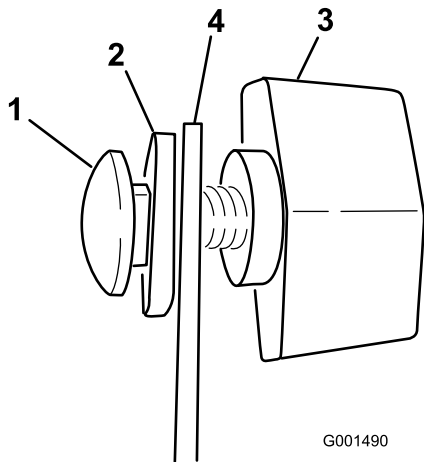

Figure 6

- | | |
|------------------|------------|
| 1. Carriage bolt | 3. Knob |
| 2. Rubber washer | 4. Bracket |

- Remove the large grommet from the hole in the dash and thread the cables on the monitor through the grommet and the dash.
- Install the grommet into the dash.
- Install the Spray Pro monitor over the carriage bolt heads (Figure 5) and tighten the knobs to secure it.
- Connect the Spray Pro wire connectors to the wire connectors located under the dash (Figure 7).

3

Checking the Boom Hinge Springs

No Parts Required

Procedure

Important: Operating the spray system with the boom hinge springs under the incorrect compression could damage the boom assembly. Measure the springs and use the jam nut to compress the springs to 1.56 inches if necessary.

The sprayer is shipped with the boom extensions swung forward to facilitate packaging of the machine. The springs are not fully tightened at the time of manufacture to allow the booms to be in this position for transit. Before operating the machine, the springs must be adjusted to the correct compression.

- If necessary, remove the packing components that secure the right and left extension booms during shipping.
- Support the booms while they are extended to the spray position.
- At the boom hinge, measure the compression of the upper and lower springs while the booms are in their extended position (Figure 8).
 - All springs must be compressed until they measure 1.56 inches.

- B. Use the jam nut to compress any spring that measure greater than 1.56 inches.

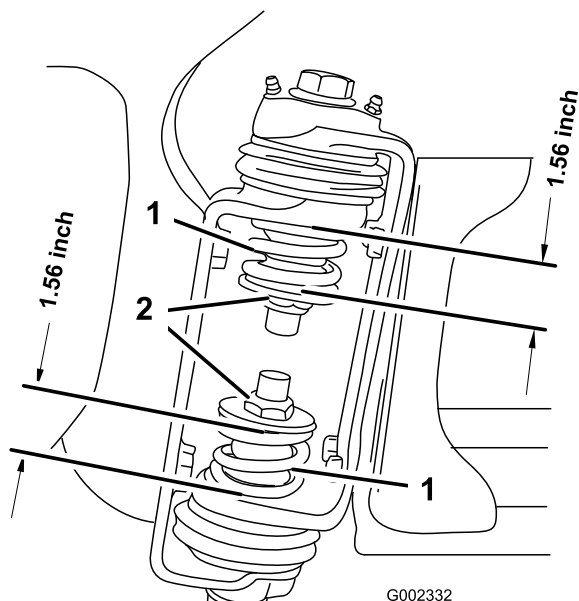

Figure 8

1. Boom hinge spring
2. Jam nut

4. Repeat the procedure for each spring on both boom hinges.
5. Move the booms into the transport “X” position. See Operating the Booms in Operation (page 25) for more information.

4

Adjusting the Booms to Level

No Parts Required

Procedure

1. At the operator’s position, turn the ignition key to On to energize the system.
2. Move the booms into position so that they are level with the ground.
3. Remove the key and exit the operator’s position.
4. At the hinge, adjust the position of the bumpers so the boom can not move past level with the ground. Take care to make sure the bumper is level.
5. Tighten the bolt and nut to lock the bumpers into the adjusted position. Torque the fasteners to 135-165 ft-lbs (183-223 N-m).

Note: The bumper may experience some compression over time. If the booms drop below level, use this procedure to readjust the bumper position needed.

5

Completing the Setup: Learning more about your product.

Parts needed for this procedure:

1	Ignition key
1	<i>Operator’s Manual</i>
1	<i>Engine Operator’s Manual</i>
1	<i>Parts Catalog</i>
1	Operator Training Material
1	Registration Card
1	Pre-delivery Inspection Sheet

Procedure

1. Read the manuals.
2. View the Operator training material.
3. Complete the registration card and return to Toro.
4. Store the documentation in a safe place.

Product Overview

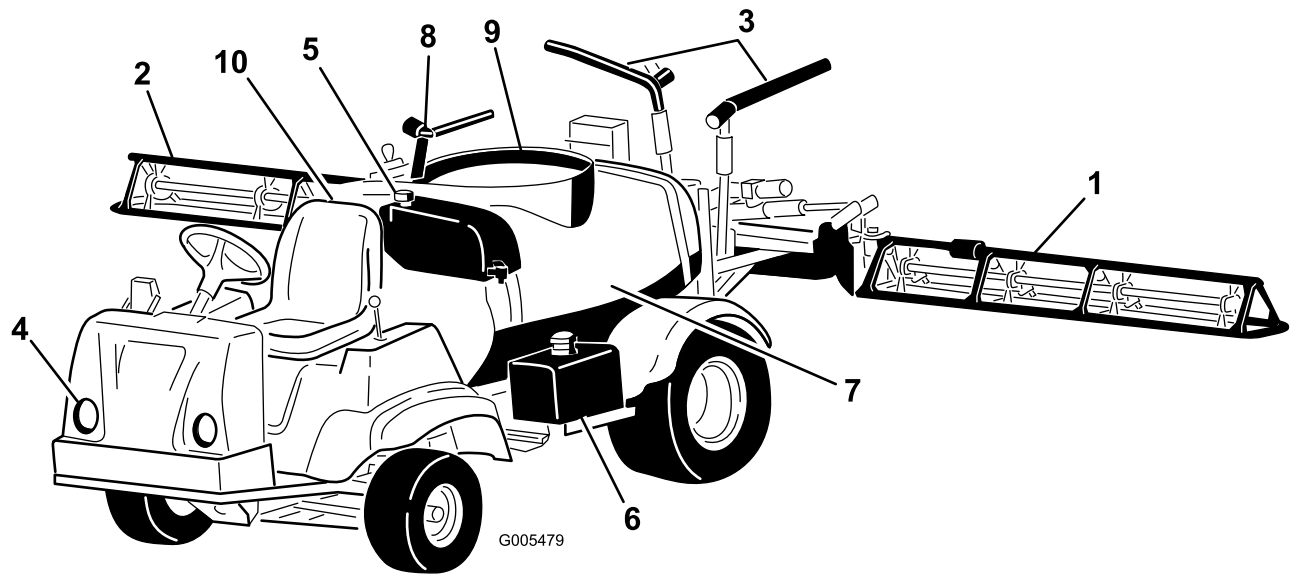

Figure 9

- | | | | |
|-------------------------|---------------------|---------------------------|-------------------------|
| 1. Left boom | 4. Headlight | 7. Chemical tank | 10. Operator's position |
| 2. Right boom | 5. Fresh water tank | 8. Anti-Siphon Receptacle | |
| 3. Boom transport cable | 6. Fuel tank | 9. Tank lid | |

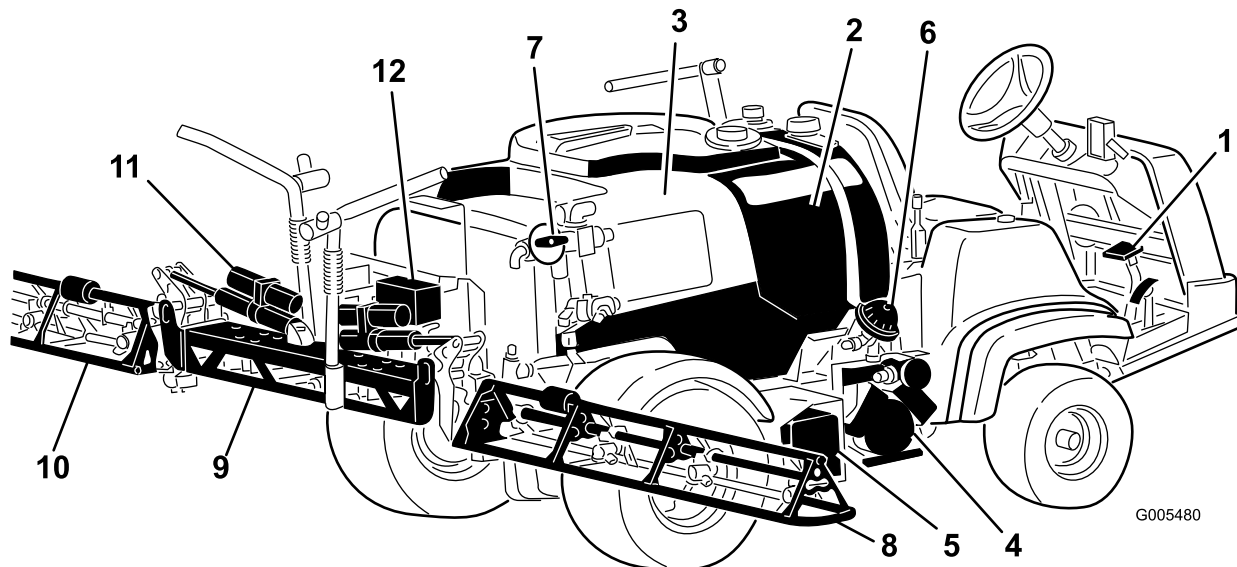

Figure 10

- | | | | |
|------------------|---------------------------|----------------------------|---------------------------|
| 1. Pedals | 4. Pump | 7. Agitation control valve | 10. Left boom |
| 2. Rinse tank | 5. Battery | 8. Right boom | 11. Boom control cylinder |
| 3. Chemical tank | 6. Pump pressure dampener | 9. Center boom | 12. Valve cluster |

Controls

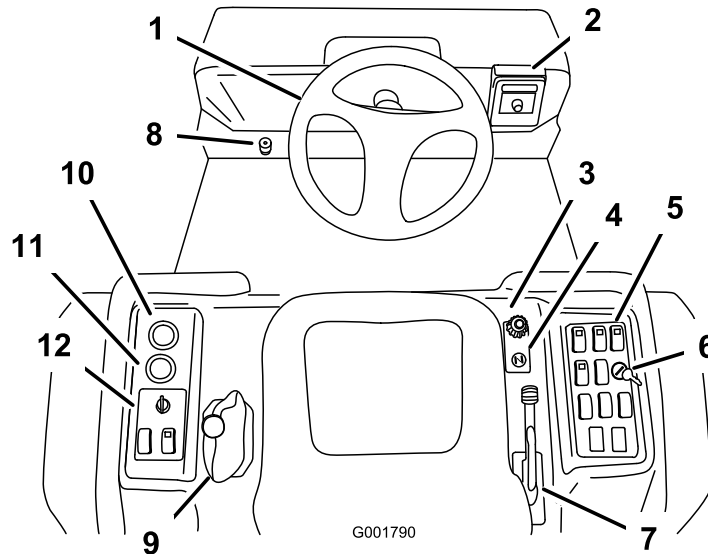

Figure 11

- | | | | |
|----------------------|------------------------|----------------------------|----------------------|
| 1. Steering wheel | 4. Choke | 7. Parking brake | 10. Voltmeter |
| 2. Spray-Pro monitor | 5. Sprayer controls | 8. Master boom foot switch | 11. Hour meter |
| 3. Speed limiter | 6. Rate lockout switch | 9. Range Selector | 12. Vehicle controls |

Accelerator Pedal

The accelerator pedal (Figure 12) gives you the ability to vary ground speed of the sprayer. Pressing the pedal increases ground speed. Releasing the pedal will slow the sprayer and the engine will idle.

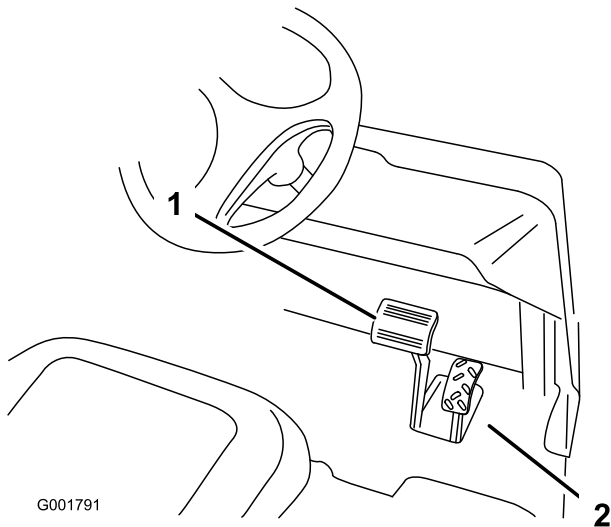

Figure 12

- | | |
|----------------|----------------------|
| 1. Brake pedal | 2. Accelerator pedal |
|----------------|----------------------|

Brake Pedal

Use the brake pedal to stop or slow the sprayer (Figure 12).

⚠ CAUTION

Brakes can become worn or can be adjusted incorrectly resulting in personal injury.

If brake pedal travels to within 1 inch (2.5 cm) of the sprayer floor board, the brakes must be adjusted or repaired.

Parking Brake

The parking brake is a large lever to the right of the seat. (Figure 13). Engage the parking brake whenever you plan on leaving the seat to prevent accidental movement of the sprayer. To engage the parking brake, pull up and back on the lever. To disengage, push it forward and down. If the sprayer is parked on a steep grade, apply the parking brake and place blocks at the downhill side of the wheels.

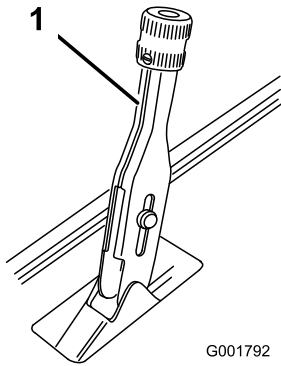

Figure 13

1. Parking brake lever

Speed Limiter

The speed limiter is a large knob located to the right of the seat (Figure 14). It allows you to set the maximum downward travel of the accelerator pedal, thereby limiting the maximum rpm of the engine. This indirectly limits the speed of the sprayer.

Note: The vehicle controls the application rate based on your speed and you do not need to keep a constant speed to apply at a constant rate.

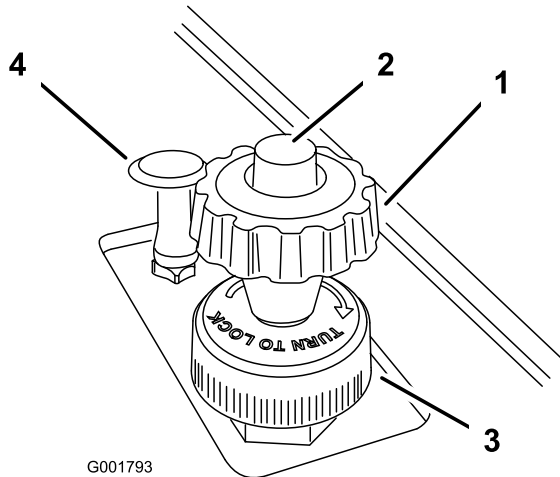

Figure 14

1. Speed limiter knob
2. Speed limiter button
3. Locking ring
4. Choke control

Choke Control

The choke control is a small knob to the right of the seat. (Figure 14). To start a cold engine, pull the choke control up. After the engine starts, regulate the choke to keep the engine running smoothly. As soon as possible, push the control down to the Off position. A warm engine requires little or no choking.

Range Selector

The range selector, located to the left of the seat, has 5 positions: 3 forward speeds, Neutral, and Reverse (Figure 15). The engine will start only when the range selector is in the Neutral position. You must also fully press the brake with the sprayer stopped to change ranges.

Important: Do not shift out of or change ranges while the vehicle is moving. Attempting to change ranges while the vehicle is moving can damage the transmission. Only stopping the sprayer completely, and fully engaging the brake will safely disengage the locking pin and allow the ranges to be changed.

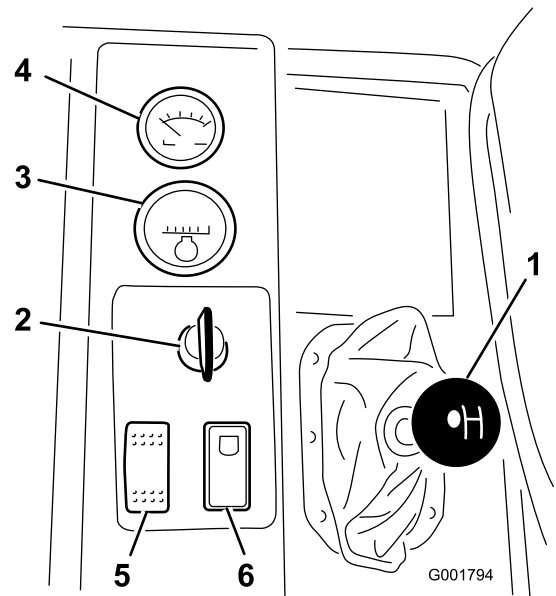

Figure 15

1. Range Selector
2. Ignition switch
3. Hour meter
4. Voltmeter
5. Headlight switch
6. Neutral engine speed lock switch

Ignition Switch

The ignition switch (Figure 15), used to start and stop the engine, has 3 positions: Stop, Run, and Start. Rotate the key clockwise to the Start position to start the engine and release it to the Run position when started. Rotate the key to the Stop position to stop the engine.

Hour Meter

The hour meter (Figure 15) indicates the total number of hours the engine has run. The hour meter starts to function whenever the key is turned to the Run position.

Voltmeter

The voltmeter (Figure 15) indicates the level of charge in the battery. When the battery is fully charged, the voltmeter will read in the center of the dial when the key is in the Run position with the engine off. When the engine is running the voltmeter needle should be to the right.

Headlight Switch

Toggle the switch to operate the headlights (Figure 15). Push it forward to turn the lights on and rearward to turn them off.

Neutral Engine Speed Lock Switch

When the range selector is in the Neutral position, you can use the accelerator pedal to speed up the engine, then push this switch forward to set the engine at that speed. This is necessary to run the chemical agitation while stationary or operating attachments such as the hand sprayer (Figure 15).

Important: The range selector must be in the neutral position for the switch to work.

Fuel Gauge

The fuel gauge is located on top of the fuel tank, on the right side of the machine and shows the amount of fuel in the tank.

Master Boom Switch

The master boom switch is located on the floor board of the machine cab and to the left of the operator. It allows you to start or stop the spray operation. Press the switch with your foot to enable or disable the spray system (Figure 16). When the master switch is off, the Spray Pro monitor screen reads "Hold."

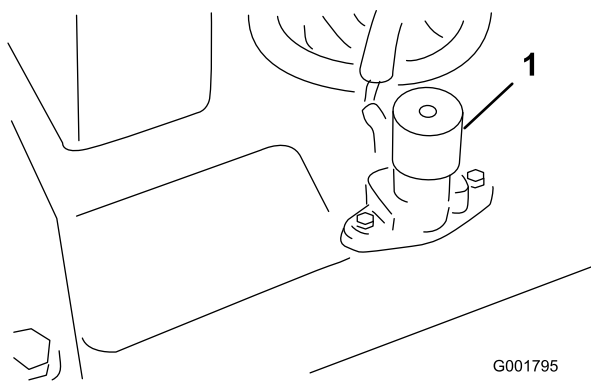

Figure 16

1. Master boom switch

Boom Switches

The boom switches are located at the front of the control panel to the right of the seat (Figure 17). Toggle each switch forward to turn the corresponding boom section on and rearward to turn them off. When the switch is turned on, a light on the switch illuminates. These switches will only affect the spray system when the master boom switch is on.

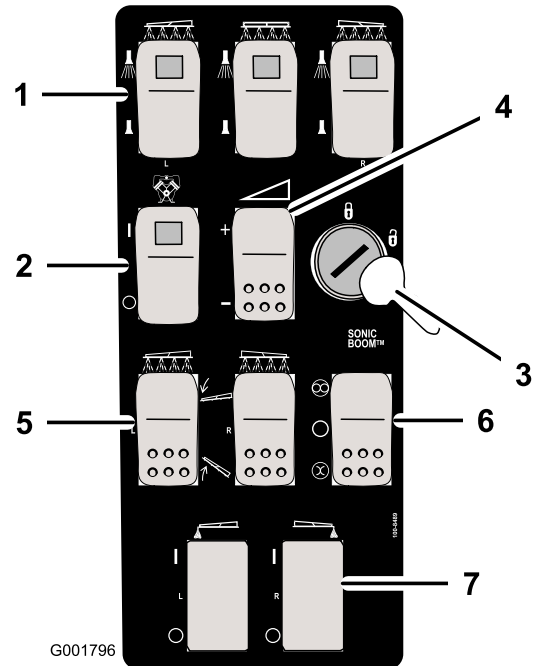

Figure 17

1. Boom switches, left, right and center
2. Pump switch
3. Rate lockout key
4. Application rate switch
5. Boom lift switch, left and right
6. Sonic boom switch
7. Foam marker switch, left and right

Pump Switch

The pump switch is located on the control panel to the right of the seat (Figure 17). Toggle this switch forward to run the pump or rearward to stop the pump.

Important: Only engage the pump switch when the engine is at low idle to avoid damaging the pump drive.

Application Rate Switch

The application rate switch is located on the control panel to the right of the seat (Figure 17). Press and hold the switch forward to increase the spray system pressure, or press and hold it rearward to decrease pressure.

Rate Lockout Key Switch

The rate lockout key switch is located on the control panel to the right of the seat (Figure 17). Turn the key counterclockwise to the locked position to disable the application rate switch, thereby keeping anyone from accidentally changing the application rate. Turn the key clockwise to the unlocked position to enable the application rate switch.

Important: Do not attempt to move the range selector while the rate lockout key is engaged. Forcing the selector while moving will damage lockout key components.

Boom Lift

The boom lift switches are used to raise the left and right boom respectively.

Sonic Boom (Optional)

The Sonic Boom switch is a rocker switch used to operate the Sonic Boom. Toggle switch forward for automatic, rearward for manual and center for Off.

Foam Marker Switch Locations (Optional)

If you install the electric boom lift, sonic boom, and foam marker kit, you will add switches to the control panel for controlling their operation. The sprayer comes with plastic plugs in these locations.

Rate Control Valve

This valve, located behind the tank (Figure 18), controls the amount of fluid that is routed to the booms by directing fluid flow to the booms or the bypass hose to the tank. You can control this valve in two ways: the application rate switch or manually. To control it manually, you need to disconnect the wire connector on the valve, then you can rotate the knob on top of the valve to manually obtain the desired pressure.

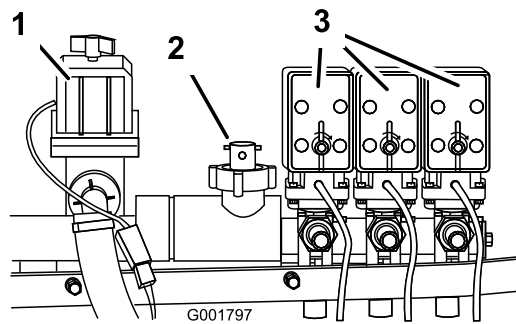

Figure 18

- 1. Rate control valve
- 2. Flowmeter
- 3. Boom valves

Flowmeter

The flowmeter measures the flow rate of the fluid for use by the Spray Pro™ system (Figure 18).

Boom Valves

These valves turn the three booms on or off (Figure 18). If you do not have a boom installed or do not want a boom to be able to be turned on, you can manually operate each valve by disconnecting the wire connector in the valve, then rotate the knob on the valve clockwise to turn the valve off or counterclockwise to turn it on.

Boom Bypass Valves

The boom bypass valves redirect the fluid flow for a boom to the tank when you turn off the boom section. You can adjust these valves to ensure that the boom pressure remains constant no matter how many booms are on. Refer to Calibrating the Boom Bypass Valves, in the Operation section.

Agitation Control Valve

This valve is located on the right side of the tank (Figure 19). Turn the knob on the valve to the 9 o'clock position to turn on the tank agitation and to the 3 o'clock position to turn off the tank agitation.

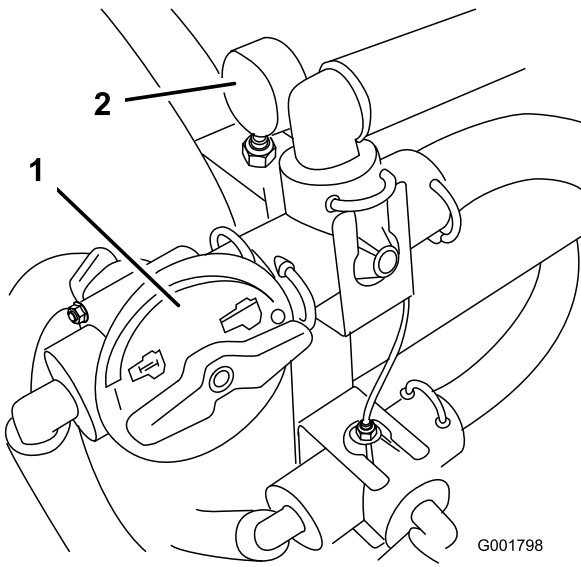

Figure 19

1. Agitation control valve 2. Pressure gauge

Pressure Gauge

The pressure gauge is located to the right of the tank (Figure 19). This gauge shows the pressure of the fluid in the system in psi and kPa. Use the gauge to adjust the by-pass valves whenever you change nozzles.

Anti-siphon Fill Receptacle

To the front of the tank cover is a hose receptacle with a threaded fitting, a 90 degree barbed fitting, and a short hose which you can direct toward the tank opening. This receptacle allows you to connect a water hose to it and fill the tank with water without contaminating the hose with the chemicals in the tank.

Important: Do not lengthen the hose to allow contact with the tank fluids.

Note: For agitation to work, the pump must be on and the engine must be running above an idle. If you stop the sprayer and need agitation on, place the range selector in the Neutral position, set the parking brake, press the accelerator pedal to the floor, turn the pump On and turn the neutral engine speed lock On.

Spray Pro™ Monitor

The Spray Pro monitor displays and monitors various system performance data such as vehicle speed and application rates. It does not control the application rate.

The monitor has an LCD screen that displays the data you select, a selection dial, and 4 buttons for calibrating the monitor (Figure 20).

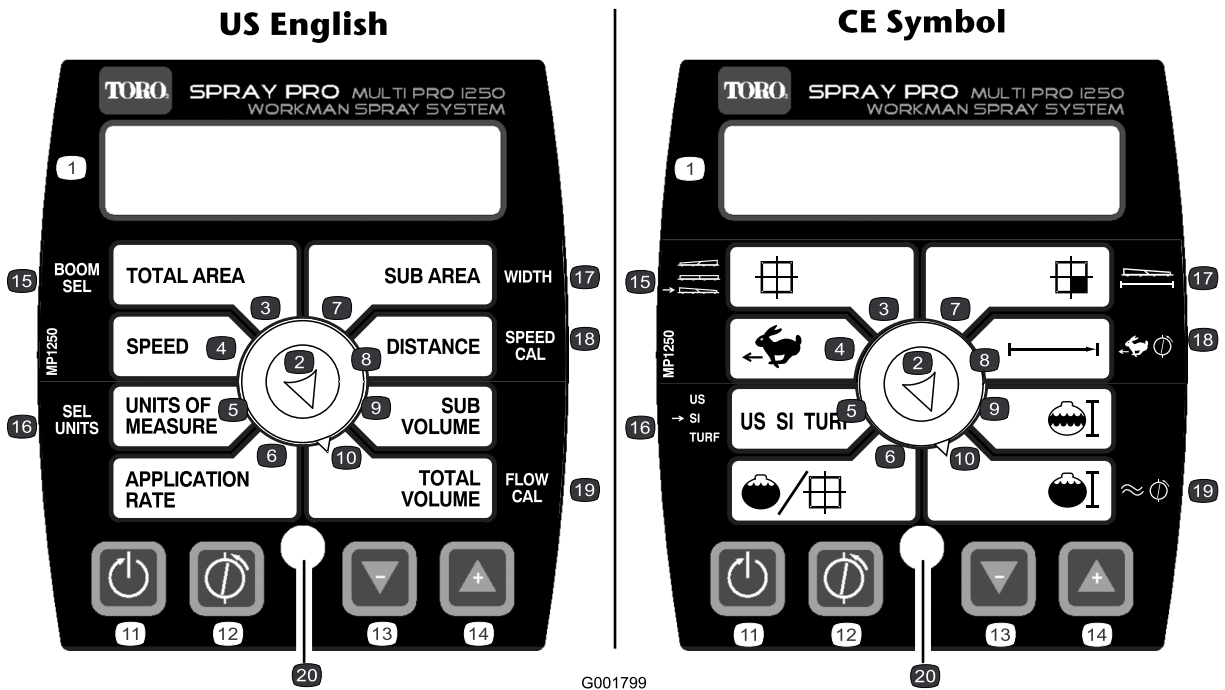

G001799

Figure 20

- | | | | |
|---------------------|---------------------|-----------------------------------|---------------------------|
| 1. LCD screen | 6. Application rate | 11. Reset, calibration button | 16. Select units |
| 2. Selection dial | 7. Sub Area | 12. Calibrate, calibration button | 17. Width |
| 3. Total area | 8. Distance | 13. Decrease, calibration button | 18. Speed calibration |
| 4. Speed | 9. Sub volume | 14. Increase, calibration button | 19. Flowmeter calibration |
| 5. Units of measure | 10. Total volume | 15. Boom selection | 20. LED |

Monitor Display Selection Dial

Use the dial to set the LCD screen display to the following:

- Total area**
 Displays the total acres (US), hectares (SI), or sq feet (TURF) that you have covered since you last pressed the Reset calibration button for this setting.
- Speed**
 Displays the ground speed in miles per hour (if the Units of Measure is set to US or TURF) or kilometers per hour (if the Units of Measure is set to SI).
- Units of Measure**
 Displays the current measurement unit selection as follows:
 - US (United States measuring system)
 - SI (metric system)
 - TURF (as US but the volumes are in US gallons per 1000 sq ft instead of US gallons per acre)

- Application Rate**
 Displays the application rate in US gallons per acre (US), liters pre hectare (SI), or US gallons per 1000 sq ft (TURF).
- Sub Area**
 Displays the total acres (US), hectares (SI), or sq feet (TURF) that you have covered since you last pressed the Reset calibration button for this setting, without affecting the Total Area display. If you press the Reset calibration button, the Sub Volume resets.
- Distance**
 Displays the distance you have traveled in feet (US and TURF) or meters (SI) since you last pressed the Reset calibration button for this setting.
- Sub Volume**
 Displays the total volume in US gallons (US and TURF) or liters (SI) that you have applied since you last pressed the Reset calibration button for this

setting, without affecting the Total Volume display. If you press the Reset calibration button, the Sub Area resets.

- **Total Volume**

Displays the total volume in US gallons (US and TURF) or liters (SI) that you have applied since you last pressed the Reset calibration button for this setting.

Calibration Buttons

The monitor has the following buttons:

- **Reset**

Resets the Total Volume, Sub Volume, Distance, Total Area, and Sub Area display settings to 0.

- **Calibrate**

Used to enter and exit the calibration mode.

- **Decrease**

Reduces values displayed on the screen during calibration.

- **Increase**

Increases values displayed on the screen during calibration.

Calibration Settings

- Boom Width
- Units of Measure
- Speed/Distance
- Flowmeter

Specifications

Note: Specifications and design are subject to change without notice.

Base weight	2,061 lb (934 kg)
Weight with standard spray system, empty, without operator	2,061 lb (934 kg)
Weight with standard spray system, full, without operator	3,661 lb (1,660 kg)
Maximum gross vehicle weight (GVW) (on level ground)	4,163 lb (1,888 kg)
Tank capacity (includes the CE 5% overflow)	175 US gallons (662 L)
Overall width with standard spray system booms stored in the X position	69 inches (175 cm)

Overall length with standard spray system	133 inches (337 cm)
Overall height with standard spray system	52 inches (132 cm)
Overall height with standard spray system to the top of the booms stored in the X position	91 inches (231 cm)
Ground clearance	4.5 inches (11.4 cm)
Wheel base	62 inches (157 cm)

Optional Equipment

The Toro Company has optional equipment and accessories that you can purchase separately and install on your sprayer. Contact your Authorized Service Dealer for a complete list of optional equipment that is currently available for your sprayer.

Operation

Note: Determine the left and right sides of the machine from the normal operating position.

Think Safety First

Please carefully read all of the safety instructions and decals in the safety section. Knowing this information could help you or bystanders avoid injury.

Before Driving the Sprayer for the First Time

Check the Engine Oil

The engine is shipped with oil in the crankcase; however, the level of oil must be checked before you first start the engine and after you have run it.

1. Position the machine on a level surface.
2. Remove the dipstick and wipe it with a clean rag (Figure 21). Insert the dipstick into the tube and make sure it is seated fully. Remove the dipstick and check the oil level.

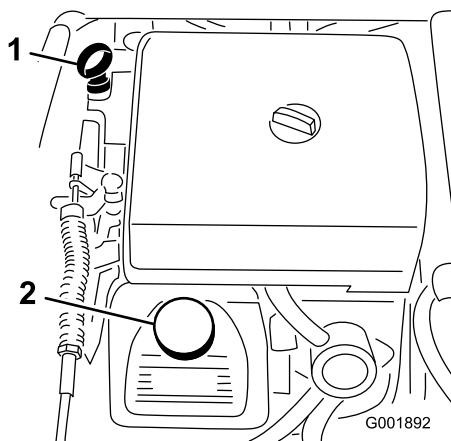

Figure 21

1. Dipstick
2. Filler cap

3. If the oil level is low, remove the filler cap from the valve cover (Figure 21) and pour oil into the opening until the oil level is up to the Full mark on the dipstick; refer to Servicing Engine Oil, the Engine Maintenance section, for the proper oil type and viscosity. Add the oil slowly and check the level often during this process. Do not overfill.
4. Install the dipstick firmly in place.

Check the Tire Pressure

Check the tire pressure every 8 hours or daily to ensure proper levels. Fill the tires to 18 psi (124 kPa). Also, check the tires for wear or damage.

Add Fuel

▲ DANGER

In certain conditions, gasoline is extremely flammable and highly explosive. A fire or explosion from gasoline can burn you and others and can damage property.

- Fill the fuel tank outdoors, in an open area, when the engine is cold. Wipe up any gasoline that spills.
- Never fill the fuel tank inside an enclosed trailer.
- Do not fill the fuel tank completely full. Add gasoline to the fuel tank until the level is 1/4 to 1/2 inch (6 to 13 mm) below the bottom of the filler neck. This empty space in the tank allows gasoline to expand.
- Never smoke when handling gasoline, and stay away from an open flame or where gasoline fumes may be ignited by a spark.
- Store gasoline in an approved container and keep it out of the reach of children. Never buy more than a 30-day supply of gasoline.
- Do not operate without entire exhaust system in place and in proper working condition.

⚠ DANGER

In certain conditions during fueling, static electricity can be released causing a spark which can ignite the gasoline vapors. A fire or explosion from gasoline can burn you and others and can damage property.

- Always place gasoline containers on the ground away from your vehicle before filling.
- Do not fill gasoline containers inside a vehicle or on a truck or trailer bed because interior carpets or plastic truck bed liners may insulate the container and slow the loss of any static charge.
- When practical, remove gas-powered equipment from the truck or trailer and refuel the equipment with its wheels on the ground.
- If this is not possible, then refuel such equipment on a truck or trailer from a portable container, rather than from a gasoline dispenser nozzle.
- If a gasoline dispenser nozzle must be used, keep the nozzle in contact with the rim of the fuel tank or container opening at all times until fueling is complete.

Recommended Gasoline

Use fresh, clean, unleaded regular gasoline suitable for automotive use (87 pump octane minimum). Leaded gasoline may be used if unleaded regular is not available.

Important: Never use gasoline containing methanol, gasoline containing more than 10% ethanol, gasoline additives, or white gas because engine fuel system damage could result.

Filling the Fuel Tank

The fuel tank capacity is approximately 5 US gallons (19 L).

Note: The fuel tank cap contains a gauge which shows the fuel level; check it frequently.

1. Shut the engine off and set the parking brake.
2. Clean the area around the fuel tank cap (Figure 22).

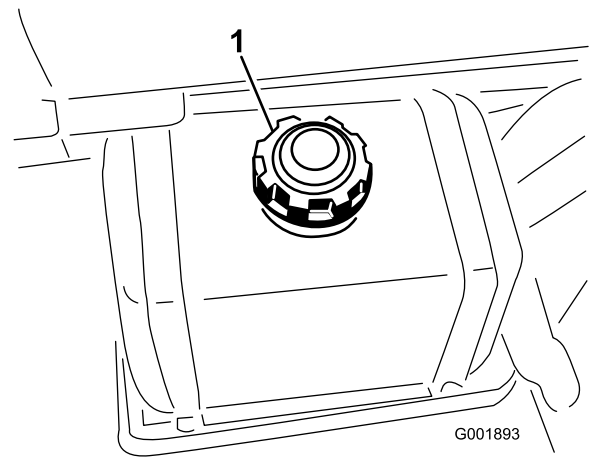

Figure 22

1. Fuel tank cap
3. Remove the fuel tank cap.
4. Fill the tank to about one inch below the top of the tank, (bottom of the filler neck). This space in the tank allows gasoline to expand. Do not overfill.
5. Install the fuel tank cap securely.
6. Wipe up any fuel that may have spilled.

Pre-Starting Checks

Check the following items each time you begin using the sprayer for the day:

- Check the tire pressure.
Note: These tires are different than car tires; they require less pressure to minimize turf compaction and damage.
- Check all fluid levels and add the appropriate amount of specified fluids, if any are found to be low.
- Check the brake pedal operation.
- Check to see that the lights are working.
- Turn the steering wheel to the left and right to check steering response.
- Check for oil leaks, loose parts, and any other noticeable malfunctions. Make sure the engine is off and all moving parts have stopped before checking for oil leaks, loose parts, and other malfunctions.

If any of the above items are not correct, notify your mechanic or check with your supervisor before taking the sprayer out for the day. Your supervisor may want you to check other items on a daily basis, so ask what your responsibilities are.

Driving the Sprayer

Starting the Engine

1. Sit in the Operator's seat, insert the key into the ignition switch, and rotate the key clockwise to the Run position.
2. Press the brake and move the range selector to the Neutral position.
3. Ensure that the pump switch is in the Off position.
4. If the engine is cold, pull the choke knob up.

Important: Do not use the choke if the engine is warm.

5. Turn the key to the Start position until the engine starts.

Important: Do not hold the key in the Start position for more than 10 seconds. If the engine has not started after 10 seconds, wait 1 minute before trying again. Do not attempt to push or tow the sprayer to start the engine.

6. Once the engine starts, push the choke knob down slowly.

Driving

1. Press the brake pedal.
2. Push the parking brake lever forward to release it.
3. Move the range selector into the desired range.
4. Press the accelerator pedal to drive or press the brake to stop.

Note: Stopping distance may vary depending on the sprayer load and speed.

Setting the Speed Limiter

1. Press down on the accelerator pedal to obtain the desired speed.
2. Press the button on top of the speed limiter knob and pull up on it until you feel it touch the accelerator pedal, then release the button (Figure 23).

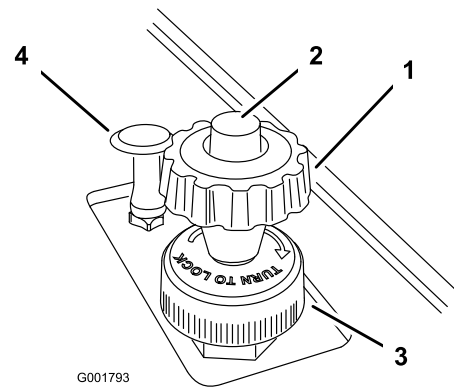

Figure 23

- | | |
|-------------------------|------------------|
| 1. Speed limiter knob | 3. Locking ring |
| 2. Speed limiter button | 4. Choke control |

3. To fine tune the setting, turn the knob in or out as needed.
4. Once you have it set, you can lock it at that setting by turning the locking ring at the base of the speed limiter clockwise until it stops (Figure 23). To release this lock, turn the locking ring counter clockwise until it is loose.
5. To release the speed limiter, press the button on the knob and lower it as far as possible.

Stopping the Engine

1. Press the brake to stop the sprayer.
2. Pull the parking brake lever up and back to set it.
3. Move the range selector out of gear into the Neutral position.
4. Turn the ignition key to the Stop position.
5. Remove the key from the switch to prevent accidental starting.

New Sprayer Break-In

To provide proper performance and long sprayer life, follow these guidelines for the first 100 operating hours:

- Check the fluid and engine oil levels regularly and be alert for indications of overheating in any component of the sprayer.
- After starting a cold engine, let it warm up for about 15 seconds before accelerating.
- Avoid hard braking situations for the first several hours of new sprayer break-in operation. New brake linings may not be at optimum performance until several hours of use has caused the brakes to become burnished (broken-in).
- Avoid racing the engine.

- Vary the sprayer speed during operation. Avoid fast starts and quick stops.
- Refer to the Maintenance section for any special low hour checks.

Adjusting the Booms to Level

The following procedure can be used to adjust the hardstops on the center boom to keep the left and right booms at level.

1. At the operator's position, turn the ignition key to On to energize the system.
2. Move the booms into position so that they are level with the ground.
3. Remove the key and exit the operator's position.
4. At the hinge, adjust the position of the bumpers so the boom can not move past level with the ground. Take care to make sure the bumper is level.
5. Tighten the bolt and nut to lock the bumpers into the adjusted position. Torque the fasteners to 135-165 ft-lbs (183-223 N-m).

Note: The bumper may experience some compression over time. If the booms drop below level, use this procedure to readjust the bumper position needed.

Operating the Sprayer

To operate the Multi-Pro Sprayer first fill the spray tank, then apply the solution to the work area, and finally clean the tank. It is important that you complete all three of these steps in succession to avoid damaging the sprayer. For example, do not mix and add chemicals in the spray tank at night and then spray in the morning. This would lead to separation of the chemicals and possible damage to the sprayer components.

⚠ CAUTION

Chemicals are hazardous and can cause personal injury.

- **Read the directions on the chemical labels before handling the chemicals and follow all manufacturer recommendations and precautions.**
- **Keep chemicals away from your skin. Should contact occur, wash the affected area thoroughly with soap and clean water.**
- **Wear goggles and any other protective equipment recommended by the chemical manufacturer.**

The Multi-Pro Sprayer has been specifically designed to have high durability in order to give it the long sprayer life you need. Different materials have been chosen for specific reasons at different locations on your sprayer to meet this goal. Unfortunately there is no single material which is perfect for all foreseeable applications.

Some chemicals are more aggressive than others and each chemical interacts differently with various materials. Some consistencies (e.g. wettable powders, charcoal) are more abrasive and lead to higher than normal wear rates. If a chemical is available in a formulation that would provide increased life to the sprayer, use this alternative formulation.

As always, remember to clean your sprayer thoroughly after all applications. This will do the most to ensure your sprayer has a long and trouble free life.

Filling the Fresh Water Tank

Always fill the fresh water tank with clean water before handling or mixing any chemicals.

The fresh water tank is located at the front, left side of the chemical tank (Figure 24). It supplies a source of fresh water for you to wash chemicals off of your skin, eyes, or other surfaces in the case of accidental exposure.

To open the fresh water tank spigot, turn the lever on the spigot.

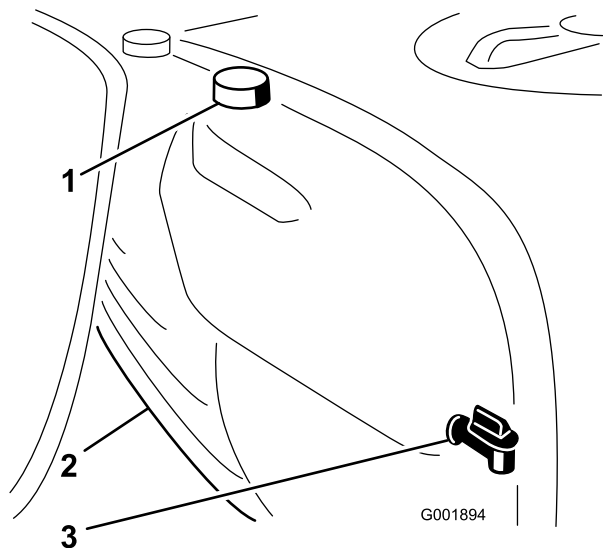

Figure 24

1. Fresh water tank
2. Filler cap
3. Spigot

Filling the Spray Tank

Important: Ensure that the chemicals you will be using are compatible for use with Viton (see the manufacturer's label; it should indicate if it is not compatible). Using a chemical that is not compatible with Viton will degrade the O-rings in the sprayer, causing leaks.

Important: Verify that the proper application rate has been set prior to filling the tank with chemicals.

1. Stop the sprayer on a level surface, move the range selector to the Neutral position, stop the engine, and set the parking brake.
2. Ensure that the tank drain valve is closed.
3. Determine the amount of water needed to mix the amount of chemical you need as prescribed by the chemical manufacturer.
4. Open the tank cover on the spray tank.

The tank cover is located in the center of the top of the tank (Figure 25). To open it, turn the front half of the cover counterclockwise and swing it open. You can remove the strainer inside for cleaning. To seal the tank, close the cover and rotate the front half clockwise.

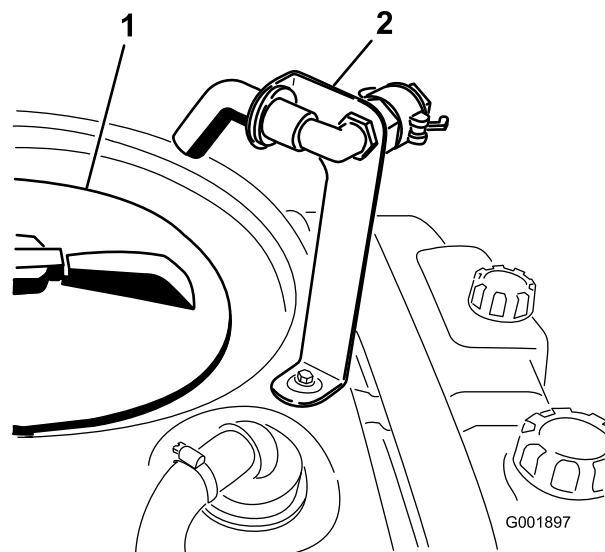

Figure 25

1. Tank cover
2. Anti-siphon fill receptacle

5. Add 3/4 of the required water to the spray tank using the anti-siphon fill receptacle.

Important: Always use fresh clean water in the spray tank. Do not pour concentrate into an empty tank.

6. Set the pump switch to the On position.
7. Start the engine, press the accelerator pedal to the floor, and set the neutral engine speed lock to the On position.
8. Set the master boom switch to the Off position. The Spray Pro monitor will display "HOLD".
9. Turn the agitation control valve to the 9 o'clock position to start agitation in the tank.
10. Add the proper amount of chemical concentrate to the tank, as directed by the chemical manufacturer.

Important: If you are using a wettable powder, mix the powder with a small amount of water to form a slurry before adding it to the tank

11. Add the remaining water to the tank.

Operating the Booms

The boom lift switches on the sprayer control panel allows you to move the booms between transport position and spray position without leaving the Operator's seat. It is recommended to change boom positions while the machine is stationary.

To change the boom position:

1. Stop the sprayer on level ground.

2. Use the boom lift switches to lower booms. Wait until the booms reach the full, extended spray position.
3. When the booms need to be retracted, stop the sprayer on level ground.
4. Use the boom lift switches to raise the booms. Raise the booms until they have moved completely into boom transport cradle forming the “X” transport position and the boom cylinders are fully retracted.
3. Set the individual boom switches, as needed, to the On positions.
4. Drive to the location where you will be spraying.
5. Turn the Spray Pro selection dial to the Application Rate position and use the application rate switch to achieve the desired rate. To do this:
 - A. Ensure the pump is On.
 - B. With the brake pressed, select the desired gear range then begin driving at maximum speed.
 - C. Verify the monitor displays the correct application rate. If needed, manipulate the application rate switch until the monitor displays the desired application rate.
 - D. Return to the location where spraying is to begin.

Important: To prevent damage to the boom actuator cylinder, make sure the actuators are fully retracted before transport.

The Boom Transport Cradle

The sprayer is equipped with a boom transport cradle that has a unique safety feature. In the event of accidental boom contact with a low overhead object while in the transport position, the boom(s) can be pushed out of the transport cradles. If this occurs, the booms will come to rest in a near horizontal position to the rear of the vehicle. While the booms will not be damaged due to this movement, they should be immediately put back into the transport cradle.

Important: The booms can be damaged by transporting them in any position other than the “X” transport position using the boom transport cradle.

To put the booms back into the transport cradle, lower the boom(s) to the spray position, and then raise the boom(s) back into the transport position. Make sure the boom cylinders are fully retracted to prevent actuator rod damage.

Spraying

Important: In order to ensure that your solution remains well mixed, use the agitation feature whenever you have solution in the tank. For agitation to work, the pump must be on and the engine must be running above an idle. If you stop the vehicle and need agitation on, place the range selector in the Neutral position, set the parking brake, press the accelerator pedal to the floor, turn on the pump, and turn the neutral engine speed lock On.

Note: This procedure assumes that the pump is on from the Filling the Spray Tank procedure.

1. Lower the booms into position.
2. Set the master boom switch to the Off position. The Spray Pro monitor will display “HOLD”.

7. When finished spraying, set the master boom switch to the Off position to turn off all booms, then set the pump switch to the Off position.
6. Set the master boom switch to the On position to begin spraying.

Note: When the tank is nearly empty, the agitation may cause foaming in the tank. In this case, turn the agitation control valve to the 3 o’clock position to turn it off. Alternatively, you can use an anti-foaming agent in the tank (if compatible with the chemical you are using).

Spraying Tips

- Do not overlap areas that you have previously sprayed.
- Watch for plugged nozzles. Replace all worn or damaged nozzles.
- Use the master boom switch to stop the spray flow before stopping the sprayer. Once stopped, place the range selector in neutral and use the neutral engine speed lock to hold the engine speed up to keep the agitation running.
- You will obtain better results if the sprayer is moving when you turn the booms on.
- Watch for changes in the application rate that may indicate that your speed has changed beyond the range of the nozzles or there is a problem with the spray system.

Cleaning the Sprayer

Important: You must always empty and clean the sprayer immediately after each use. Failure to do

so may cause the chemicals to dry or thicken in the lines, clogging the pump and other components.

Clean the spray system after **each** spraying session. To properly clean the spray system:

- Use three separate rinses.
- Use a minimum of 50 gallons for each rinse.
- Use the cleaners and neutralizers as recommended by the chemical manufacturers.
- Use pure clean water (no cleaners or neutralizers) for the **last** rinse.

The rinse tank is located at the front, right side of the chemical tank (Figure 26). If you install the optional Rinse Kit, you can fill this tank with fresh water and automatically rinse the main tank, boom supply lines and nozzles.

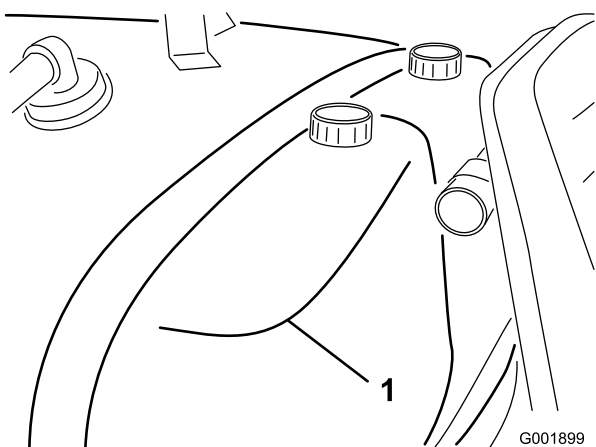

Figure 26

1. Rinse tank (for use with the optional rinse kit, 106-4842)

1. Stop the sprayer, set the parking brake, place the range selector in the Neutral position, and turn off the engine. The tank will drain to left side of the machine.
2. Locate the tank drain valve on the left side of the machine (Figure 27). The valve is on the frame in front of the fuel tank.

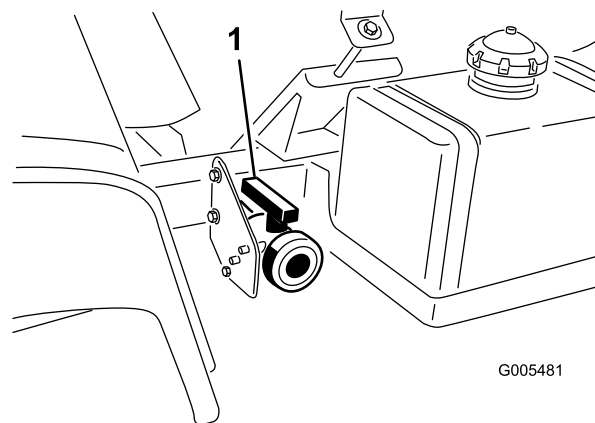

Figure 27

1. Tank drain handle

Open the valve to drain any unused material from the tank and dispose of it according to local codes and the material manufacturer's instructions (Figure 28). After draining, remove the lynch pin on the bracket securing the drain valve to the machine and let the valve rest on the ground. This allows any residual material in the line to drain.

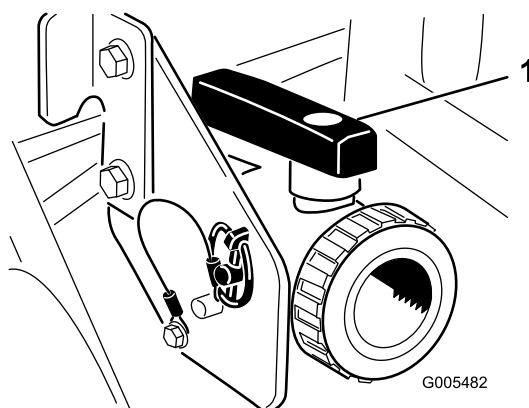
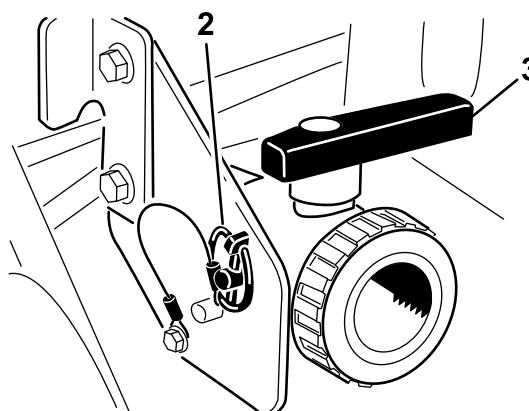

Figure 28

1. Valve open
2. Lynch pin
3. Valve closed

3. When the tank has drained completely, install the valve to frame with the lynch pin removed previously and close the drain valve (Figure 28).
4. Fill the tank with at least 50 US gallons (190 L) of clean fresh water and close the cover.

Note: You can use a cleaning/neutralizing agent in the water as needed. On the final rinse, use only clean, clear water.

5. Start the engine.
6. With the range selector in the Neutral position, press the accelerator pedal to the floor and set the neutral engine speed lock switch to the On position.
7. Ensure that the agitation control valve is in the On position.
8. Set the pump switch to the On position and use the application rate switch to increase the pressure to a high setting.
9. Set the master boom switch and boom control switches to the On positions to begin spraying.
10. Allow all of the water in the tank to spray out through the nozzles.
11. Check the nozzles to ensure that they are all spraying correctly.
12. Set the master boom switch to the Off position, set the pump switch to the Off position, and stop the engine.
13. Repeat steps 4 through 12 at least 2 more times to ensure that the spray system is fully cleaned. On the last cycle, run the last few gallons of water through the drain valve to clear the drain tubing.
14. Clean the strainer; refer to Cleaning the Suction Strainer in the Cleaning section.

Important: If you used wettable powder chemicals, clean the strainer after each tank.

15. Using a garden hose, spray off the outside of the sprayer with clean water.
16. Remove the nozzles and clean them by hand. Replace damaged or worn nozzles.

Calibrating the Spray Pro Monitor

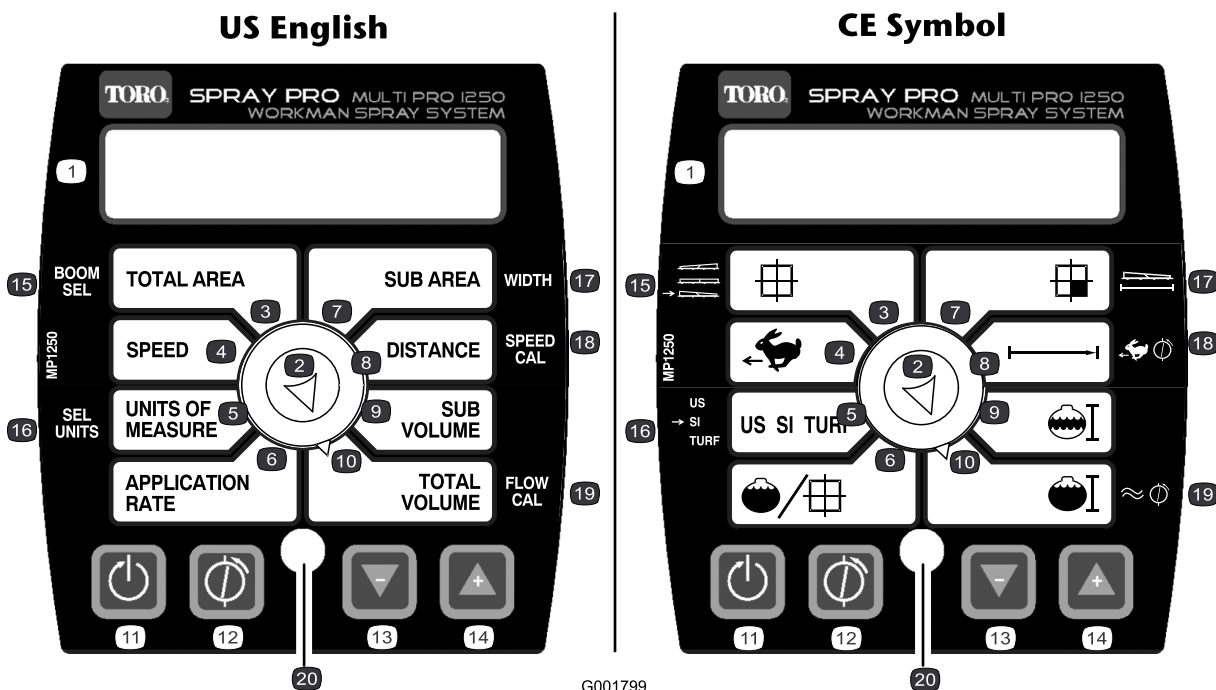

G001799

Figure 29

- | | | | |
|---------------------|---------------------|-----------------------------------|---------------------------|
| 1. LCD screen | 6. Application rate | 11. Reset, calibration button | 16. Select units |
| 2. Selection dial | 7. Sub Area | 12. Calibrate, calibration button | 17. Width |
| 3. Total area | 8. Distance | 13. Decrease, calibration button | 18. Speed calibration |
| 4. Speed | 9. Sub volume | 14. Increase, calibration button | 19. Flowmeter calibration |
| 5. Units of measure | 10. Total volume | 15. Boom selection | 20. LED |

The Spray Pro monitor has a calibration mode that allows you to change various settings to customize the display and calibrate the monitor to your needs. You can calibrate or change the following settings:

- Boom Width
- Units of Measure
- Speed
- Flowmeter

Setting the Boom Width

The default settings for the boom widths are 80 inches (2.03 m) for the right and left booms and 60 (1.524 m) for the center boom. This is based on 4 nozzles on the right and left booms and 3 on the center boom all spaced 20 inches (50.8 cm) apart. If you change the spacing of the nozzles, you should change the boom width to reflect your changes as follows:

1. Stop the sprayer and set the parking brake.
2. Set the master boom switch to the Off position. The monitor displays “HOLD”.

3. Press and hold the Calibrate button until the monitor displays “CAL HOLD” and the red light on the monitor illuminates.
4. Turn the selection dial to the Boom Select (or Total Area) position.
5. Use the Increase or Decrease calibration buttons to select the boom for which you wish to change the width, where 1 is the left boom, 2 is the center boom, and 3 is the right boom.
6. Turn the selection dial to the Width (or Sub Area) position.
7. Use the Increase or Decrease calibration buttons to change the boom width as needed.
8. Repeat steps 4 through 7 for the other booms as needed.
9. Press the Calibrate button until the red light turns off. You can also exit the calibration mode by driving the sprayer.

Setting the Units of Measure

The default setting for the units of measure is US. You can also change the units to SI (metric) or TURF.

1. Stop the sprayer and set the parking brake.
2. Set the master boom switch to the Off position. The monitor displays “HOLD”.
3. Press and hold the Calibrate button until the monitor displays “CAL HOLD” and the red light on the monitor illuminates.
4. Turn the selection dial to the Select Units (or Units of Measure) position.
5. Use the Increase or Decrease calibration buttons to select desired units of measure.
6. Press the Calibrate button until the red light turns off. You can also exit calibration mode by driving the sprayer.

Calibrating the Flowmeter

Note: Perform this calibration procedure each time nozzles are changed to ensure the greatest accuracy.

The Spray Pro monitor comes approximately calibrated for the flowmeter. Complete the following procedure to fine tune the flowmeter calibration:

1. Set the parking brake.
2. Fill the sprayer tank with a known quantity of water, at least 100 US gallons (380 L).

Note: Do not rely on the marks on the side of the tank for measuring the water for this procedure. They are approximate measurements, but not accurate enough for this calibration.

3. Set the pump switch to the On position to start the pump.
4. Set all three boom switches and the master boom switch to the On position. Run the booms only until the air is purged from the line, then turn them off using the master boom switch.
5. Turn the selection dial to the Total Volume position.
6. Press and hold the Reset calibration button until the display reads “0”.
7. Set the master boom switch to the On position and run the booms until all the water is out of the tank, then stop them using the master boom switch.
8. Compare the volume displayed on the monitor to the volume of water you put into the tank.
 - If the volumes are the same, you do not need to calibrate the monitor any further.
 - If the values are different, continue with the rest of this procedure.
9. With the selection dial set to the Total Volume position, press and hold the Calibrate button until the monitor displays “CAL HOLD” and the red light on the monitor illuminates.

The display will alternate between the total volume reading (“HOLD” shown) and the flow calibration value (“CAL HOLD” shown).

10. When the total volume value is displayed, use the Increase or Decrease calibration buttons to change it to the amount of water you put in the tank.
11. When the display begins alternating again, the flow calibration value will have changed; write this number down and save it. This is the calibration value for your sprayer.
12. Press the Calibrate button until the red light turns off. You can also exit calibration mode by driving the sprayer.

Calibrating the Speed Sensor

The Spray Pro comes approximately calibrated for the speed sensor. Complete the following procedure to fine tune the speed sensor calibration:

1. Check and fill all tires; refer to Checking Tire Pressure in the Drive System Maintenance section.
2. Fill the fresh water tank.
3. Fill the sprayer tank half-full of water.
4. Select a straight, flat track of ground that is similar to your turf conditions.

Note: Using a road or other paved surface could cause an inaccurate reading when you later drive the sprayer on turf.

5. Measure 500 feet (150 m), marking both the start and end points.
6. Position the sprayer at the starting point.
7. Set the pump and the master boom switches to the Off position. The monitor should display “HOLD”.
8. Turn the selection dial to the Distance position.
9. Press and hold the Reset calibration button until the display reads “0”.
10. Press the master boom switch to start the distance tracking with the monitor. Drive the machine from the start point you marked to the 500 feet (150 m) end point.
11. Stop at the end point, set the master boom switch to the Off position to stop the monitor.
12. Look at the distance displayed on the monitor.
 - If it reads “500 feet (150 m)”, you do not need to calibrate the monitor any further.
 - If it does not read “500 feet (150 m)”, continue with the rest of this procedure.
13. Set the parking brake.

14. With the selection dial set to the Distance position, press and hold the Calibrate button until the monitor displays “CAL HOLD” and the red light on the monitor illuminates.
The display will alternate between the distance value (“HOLD” shown) and the speed calibration value (“CAL HOLD” shown).
15. When the distance value is displayed, use the Increase or Decrease calibration buttons to change it to 500 feet (150 m).
16. When the display begins alternating again, the speed calibration value will have changed; write this number down and save it. This is the calibration value for your sprayer.
17. Press the Calibrate button until the red light turns off. You can also exit calibration mode by driving the sprayer.

Resetting an OFL Condition

If the monitor reads “OFL”, it indicates that you have exceeded the monitor screen dimensions. Press and hold the Reset calibration button to set the display to 0.

Calibrating the Boom Bypass Valves

Before using the sprayer for the first time or if the nozzles are changed, adjust the boom bypass valves so that the pressure and application rate remains the same for all booms when you turn one or more booms off.

Note: The boom bypass valves must be calibrated each time the nozzles are changed.

Select an open flat area to perform this procedure.

1. Fill the spray tank with clean water.
2. Put the extension booms down, if installed.
3. Set the parking brake and start the engine.
4. Set the dial on the Spray Pro monitor to Application Rate.
5. Place the range selector in the Neutral position.
6. Press the accelerator to the floor and set the neutral engine speed lock switch to the On position.
7. Set the pump switch to the On position to start the pump.
8. Set all three boom switches and the master boom switch to the On position.
9. Use the application rate switch to adjust the pressure as read on the pressure gauge until it is in the range

for the nozzles you installed on the booms (typically 40 psi/2.75 bar).

10. Record the reading on the pressure gauge.
11. Turn off one of the booms using the appropriate boom switch.
12. Adjust the boom bypass valve (Figure 30) under the boom control valve for the boom you turned off until the pressure reading on the gauge is the same as it was in step 9.

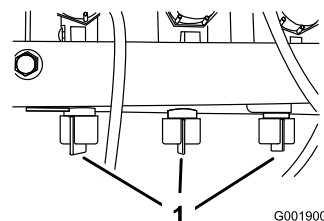

Figure 30

1. Boom bypass valves

13. Turn the boom on and off to verify the pressure does not change.
14. Repeat steps 11 through 13 for the other booms.
15. Drive the sprayer at the desired speed while spraying and turn each boom off individually. The pressure on the gauge should not change.

Pump

The pump is located near the front of the tank on the right side (Figure 31).

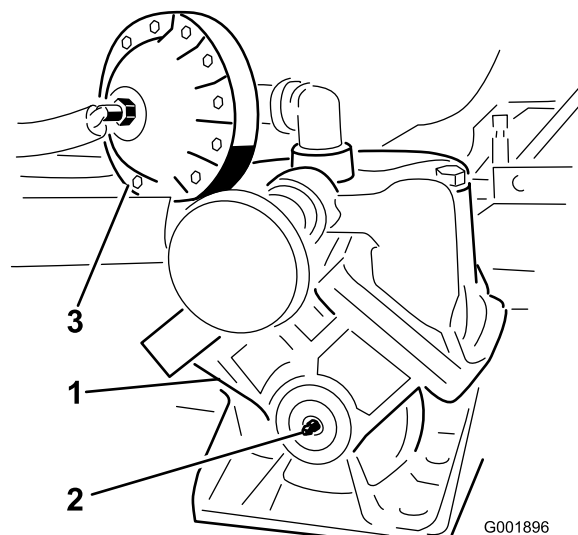

Figure 31

1. Pump
2. Grease fitting
3. Pressure dampener

Adjusting the Air Pressure in Dampener

The air pressure in the dampener on the pump is set at 15 psi (1 bar) by the manufacturer. The recommended pressure in the dampener is 1/3 of the spraying pressure. If using a spray pressure greater than 45 psi (3.1 bar) adjust the dampener accordingly.

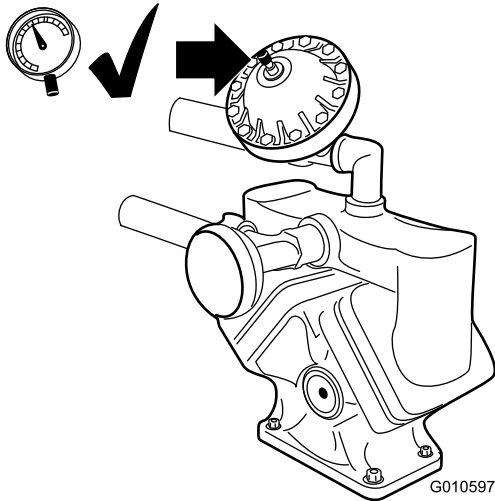

Figure 32

Towing the Sprayer

In case of an emergency, the sprayer can be towed for a short distance. However, we do not recommend this as a standard procedure.

▲ WARNING

Towing at excessive speeds could cause a loss of steering control, resulting in personal injury.

Never tow the sprayer faster than 5 mph (8 kph).

Towing the sprayer is a two person job. If the machine must be moved a considerable distance, transport it on a truck or trailer; refer to Transporting the Sprayer.

1. Affix a tow line to the frame.
2. Put the range selector in the Neutral position and release the parking brake.
3. Tow the sprayer at less than 5 mph (8 kph).

Transporting the Sprayer

For moving the sprayer long distances, use a trailer. Secure the sprayer to the trailer. Figure 33 illustrates the front tie-down points.

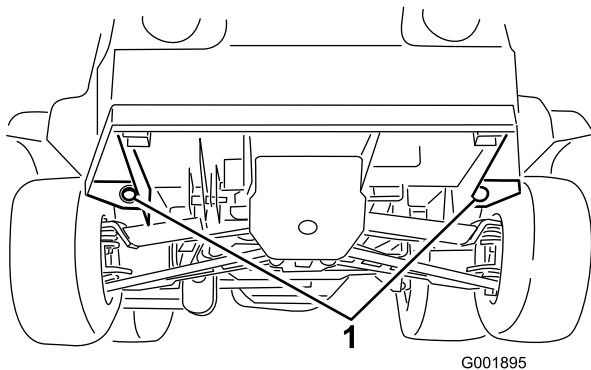

Figure 33

1. Tie down points

The rear tie-down points are two steel loops under the back of the frame just in front of the adjustable boom frame.

Maintenance

Note: Determine the left and right sides of the machine from the normal operating position.

Recommended Maintenance Schedule(s)

Maintenance Service Interval	Maintenance Procedure
After the first 8 hours	<ul style="list-style-type: none"> • Torque the wheel lug nuts. • Check the drive belt. • Check the steering pump belt tension. • Replace the hydraulic filter.
After the first 50 hours	<ul style="list-style-type: none"> • Change the engine oil.
Before each use or daily	<ul style="list-style-type: none"> • Check pump dampener pressure. • Check the engine rotating screen. • Check the engine oil. • Check the tire pressure. • Check pump dampener pressure. • Clean the suction strainer. (more often when using wettable powders)
Every 25 hours	<ul style="list-style-type: none"> • Clean and oil the foam air cleaner (more often in dusty, dirty conditions).
Every 50 hours	<ul style="list-style-type: none"> • Lubricate the pump. • Check the battery cable connections. • Check the battery electrolyte level.
Every 100 hours	<ul style="list-style-type: none"> • Lubricate all grease fittings. • Lubricate the boom hinges. • Clean the engine rotating screen (more often in dusty, dirty conditions). • Replace the paper air cleaner element (more often in dusty, dirty conditions). • Change the engine oil, including synthetic oil (more often when operating under heavy load or in high temperature). • Replace the engine oil filter. • Replace the fuel filter. • Check the operation of the Neutral gear shift position. • Torque the wheel lug nuts. • Inspect the condition and wear of the tires. • Check front wheel toe-in. • Inspect the brakes. • Check the steering pump belt tension.
Every 200 hours	<ul style="list-style-type: none"> • Change the spark plugs. • Check the shift cables. • Check the parking brake. • Check the drive belt. • Check the transaxle/hydraulic fluid. • Inspect all hoses and connections for damage and proper attachment.
Every 400 hours	<ul style="list-style-type: none"> • Grease the actuator rod bearings. • Complete all yearly maintenance procedure specified in the engine operator's manual. • Inspect the fuel lines. • Clean and lubricate the primary drive clutch. • Inspect the pump diaphragm and replace if necessary. (see an Authorized Toro Service Distributor) • Inspect the pressure dampener bladder and replace if necessary. (see an Authorized Toro Service Distributor) • Inspect the pump check valves and replace if necessary. (see an Authorized Toro Service Distributor) • Change the pump drive gearbox fluid. • Check boom actuator hydraulic oil for air bubbles. • Inspect the center boom nylon pivot bushings.

Maintenance Service Interval	Maintenance Procedure
	<ul style="list-style-type: none"> Inspect the O-rings in the valve assemblies and replace them if necessary.
Every 800 hours	<ul style="list-style-type: none"> Change the transaxle/hydraulic fluid and clean strainer. Replace the hydraulic filter.

Important: Refer to your engine *Operator's Manual* for additional maintenance procedures.

Daily Maintenance Checklist

Duplicate this page for routine use.

Maintenance Check Item	For the week of:						
	Mon.	Tues.	Wed.	Thurs.	Fri.	Sat.	Sun.
Check the brake and parking brake operation.							
Check the gear shift/neutral operation.							
Check the fuel level.							
Check the engine oil level.							
Check the transaxle oil level.							
Inspect the air filter.							
Inspect the engine cooling fins.							
Check any unusual engine noises.							
Check any unusual operating noises.							
Check the tire pressure.							
Check for fluid leaks.							
Check the instrument operation.							
Check the accelerator operation.							
Clean the suction strainer.							
Check toe-in.							
Lubricate all grease fittings. ¹							
Touch up and damaged paint.							

¹Immediately after every washing, regardless of the interval listed

Notation for Areas of Concern

Inspection performed by:		
Item	Date	Information
1		
2		
3		
4		
5		
6		
7		
8		
9		
10		
11		
12		

⚠ CAUTION

If you leave the key in the ignition switch, someone could accidentally start the engine and seriously injure you or other bystanders.

Remove the key from the ignition and disconnect the wire(s) from the spark plug(s) before you do any maintenance. Set the wire(s) aside so that it does not accidentally contact the spark plug(s).

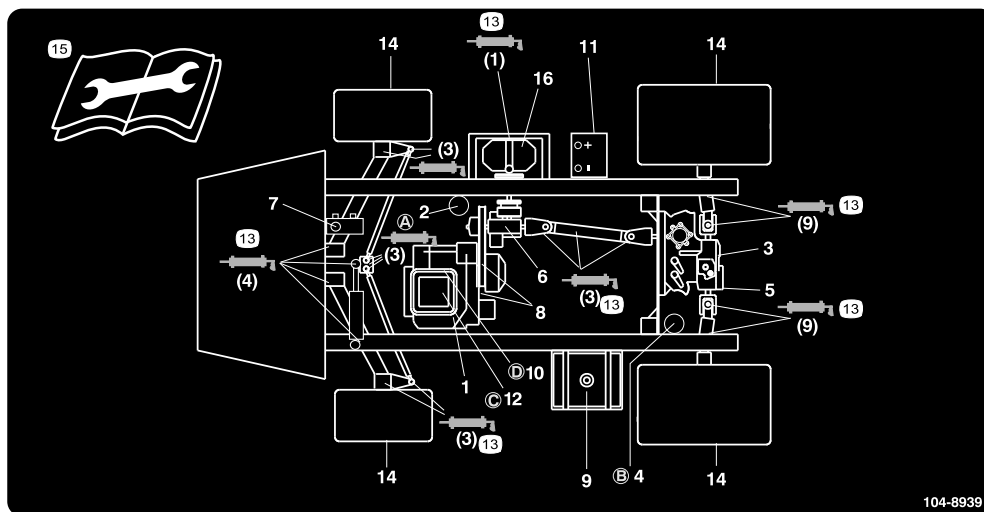

Figure 34
Service locations

- | | | | |
|---|------------------------------|------------------------|---|
| 1. Engine oil level (dipstick) | 5. Hydraulic strainer | 9. Fuel, unleaded only | 13. Grease |
| 2. Engine oil filter | 6. Gear box fluid level | 10. Fuel filter | 14. Tire pressure |
| 3. Transaxle/hydraulic fluid level (dipstick) | 7. Brake fluid | 11. Battery | 15. Read the instructions before servicing or performing maintenance. |
| 4. Transaxle hydraulic filter | 8. Belts, steering and drive | 12. Air cleaner | 16. Pump |

Premaintenance Procedures

Jacking the Sprayer

Whenever the engine is run for routine maintenance and/or engine diagnostics, the rear wheels of the sprayer should be 1 inch (25 mm) off of the ground with the rear axle supported on jack stands.

⚠ DANGER

A sprayer on a jack may be unstable and slip off of the jack, injuring anyone beneath it.

- Do not start the engine while the sprayer is on a jack.
- Always remove the key from the ignition before getting off of the sprayer.
- Block the tires when the sprayer is on a jack.

The jacking point at the front of the sprayer is under the A-arms (Figure 35)

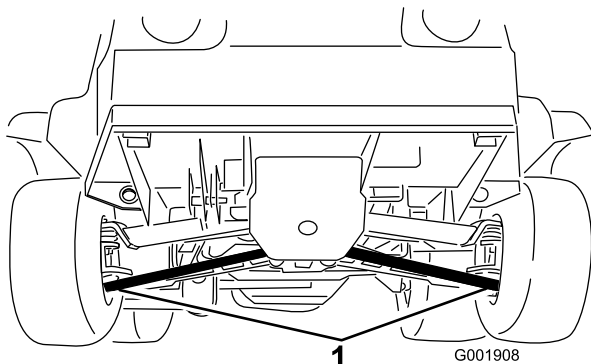

Figure 35

1. Front jacking points

The jacking point at the rear of the sprayer is on the rear frame support, between the angle welds (Figure 36).

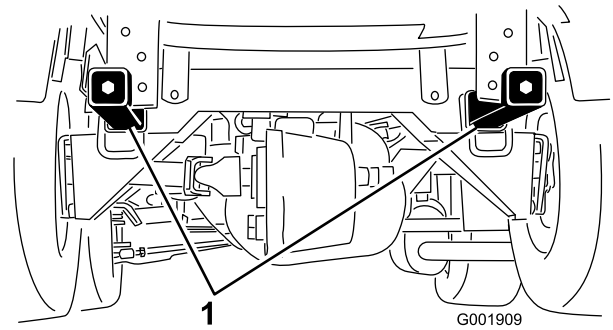

Figure 36

1. Rear jacking points

Lubrication

Greasing the Sprayer

Service Interval: Every 50 hours—Lubricate the pump.

Every 100 hours/Yearly (whichever comes first)—Lubricate all grease fittings.

Grease Type: No. 2 General Purpose Lithium Base Grease

1. Wipe the grease fitting clean so that foreign matter cannot be forced into the bearing or bushing.
2. Pump grease into the bearing or bushing.
3. Wipe off excess grease.

The grease fittings positions are illustrated by the following: Figure 38 through Figure 43.

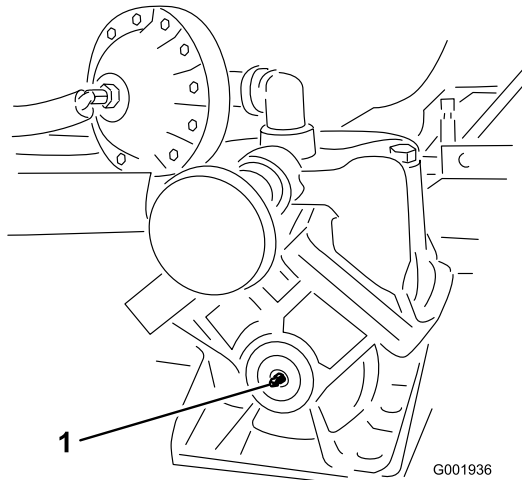

Figure 37

Pump (Do not over grease)

1. Grease point

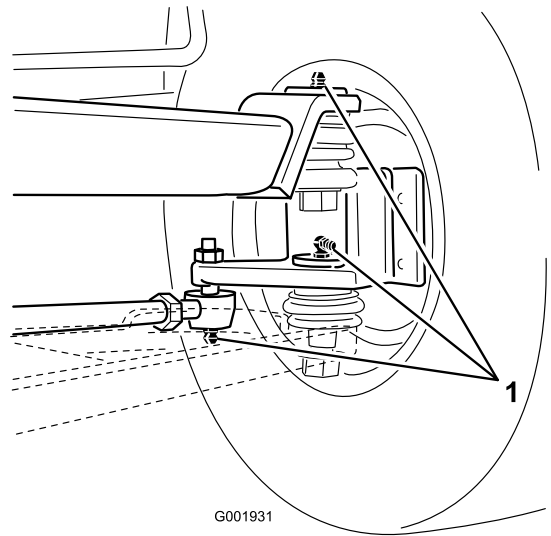

Figure 38

At the wheels, three on each side

1. Grease point

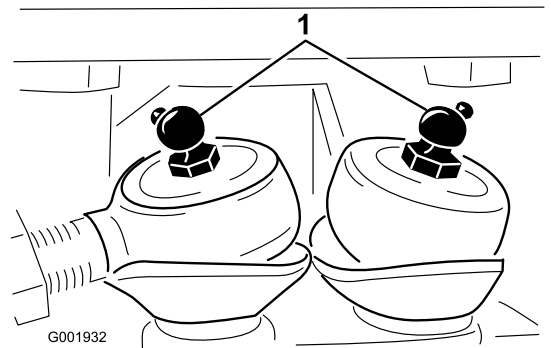

Figure 39

Steering rods

1. Grease point

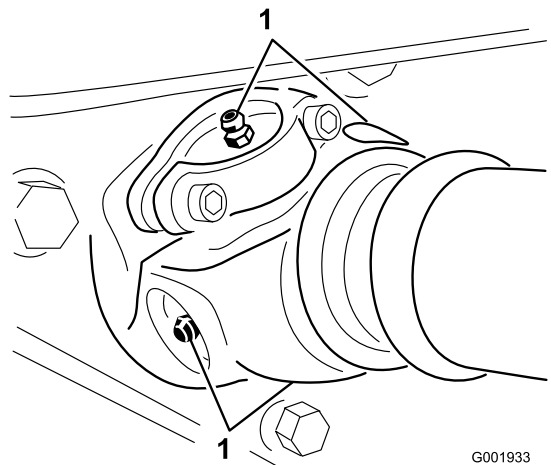

Figure 40

Pump drive, four, one each side

1. Grease point

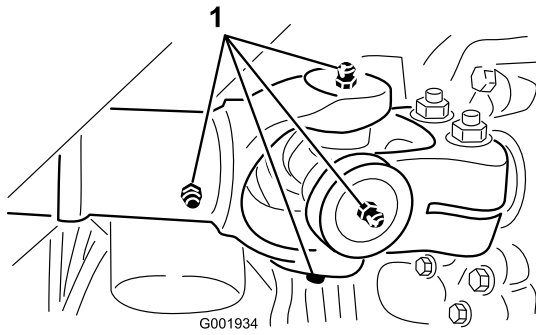

Figure 41

Drive axel at engine, five, one each side and slip joint

1. Grease point

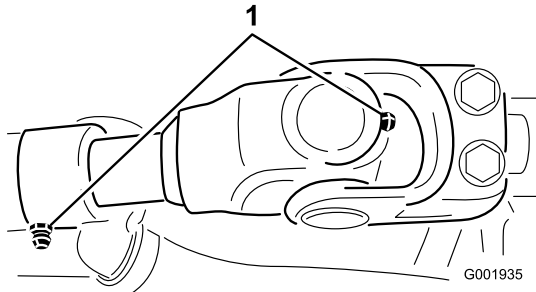

Figure 42

Drive axel at transmission

1. Grease point

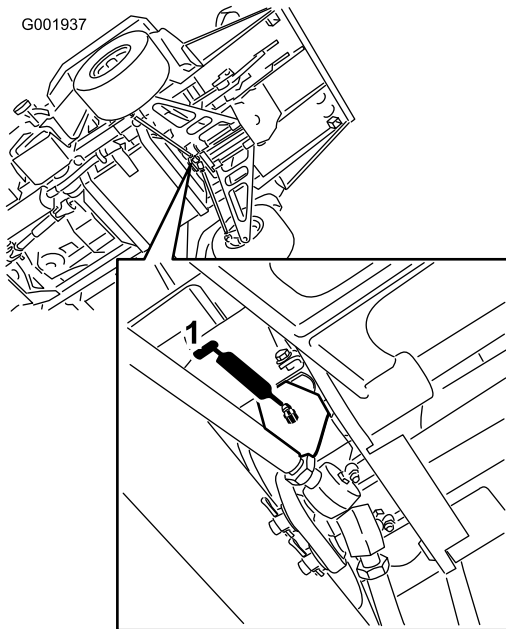

Figure 43

Steering pivot above steering rods

1. Grease point

Greasing the Boom Hinges

Service Interval: Every 100 hours

Important: If the boom hinge is washed with water, all water and debris must be cleared from the hinge assembly and fresh grease must be applied.

Grease Type: No. 2 general-purpose lithium base grease.

1. Wipe the grease fittings clean so that foreign matter cannot be forced into the bearing or bushing.
2. Pump grease into the bearing or bushing at each fitting Figure 44.

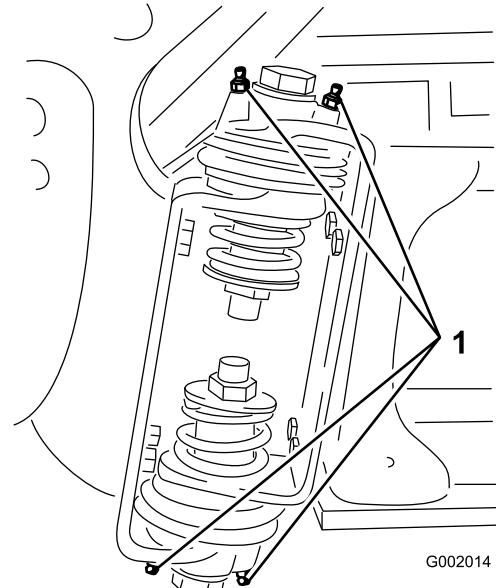

Figure 44

Right boom

1. Grease fitting
3. Wipe off excess grease.
4. Repeat the procedure for each boom pivot.

Greasing the Actuator Rod Bearings

Service Interval: Every 400 hours/Yearly (whichever comes first)

Grease Type: No. 2 general-purpose lithium base grease.

1. Extend the booms to the spray position.
2. Remove the cotter pin from the pivot pin (Figure 45).

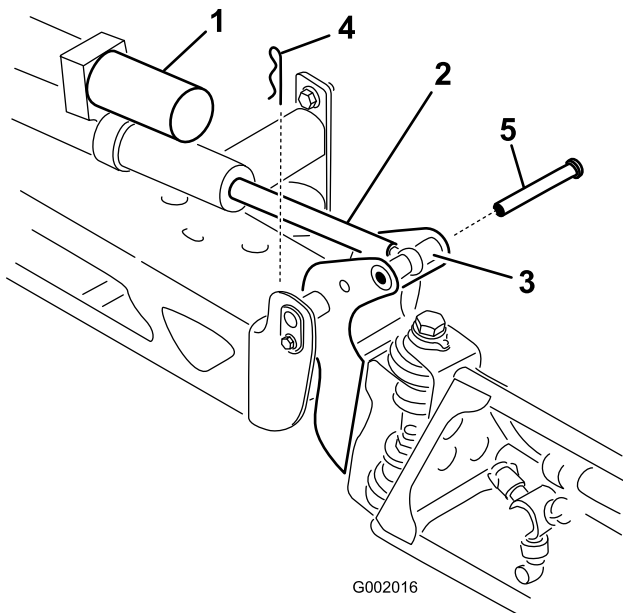

Figure 45

- | | |
|---------------------------|-----------|
| 1. Actuator | 4. Cotter |
| 2. Actuator rod | 5. Pin |
| 3. Boom pivot pin housing | |

7. With the pin in place, release the boom and secure the pin with the cotter removed previously.
8. Repeat the procedure for each actuator rod bearing.

3. Lift up on the boom and remove the pin (Figure 45). Slowly lower the boom to the ground.
4. Inspect the pin for any damage, replace if necessary.
5. Manipulate the actuator rod bearing end and apply grease into the bearing (Figure 46). Wipe off excess grease.

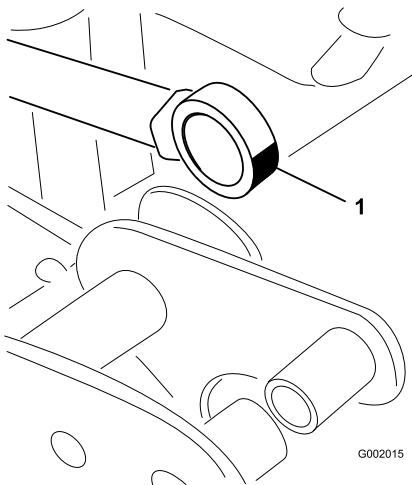

Figure 46
Right boom

1. Grease bearing

6. Raise the boom to align the pivot with the actuator rod. While holding the boom, insert the pin through both boom pivot and actuator rod (Figure 45).

Engine Maintenance

Checking the Air Intake Screen

Service Interval: Before each use or daily—Check the engine rotating screen.

Every 100 hours—Clean the engine rotating screen (more often in dusty, dirty conditions).

Check and clean as necessary the air intake screen on the front of the engine before each use or daily.

Servicing the Air Cleaner

Foam Element: Clean and oil after every 25 operating hours, or yearly, whichever occurs first.

Paper Element: Replace after every 100 operating hours or yearly, whichever occurs first.

Note: Service the air cleaner more frequently (every few hours) if operating conditions are extremely dusty or dirty.

Removing the Foam and Paper Elements

1. Set the parking brake, stop the pump, stop the engine, and remove the ignition key.
2. Release the latch on the back of the seat and lift the seat forward.
3. Clean around the air cleaner to prevent dirt from getting into the engine and causing damage (Figure 47).

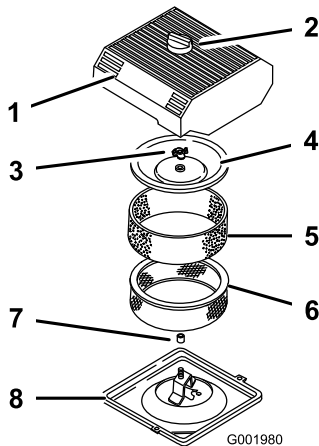

Figure 47

- | | |
|----------------------|---------------------|
| 1. Air cleaner cover | 5. Foam element |
| 2. Knob | 6. Paper element |
| 3. Cover nut | 7. Rubber seal |
| 4. Cover | 8. Air cleaner base |

4. Loosen the knob on the air cleaner cover and remove the cover (Figure 47).
5. Carefully slide the foam element off the paper element (Figure 47).
6. Unscrew the cover nut and remove the cover and paper element (Figure 47).

Cleaning the Foam Element

Service Interval: Every 25 hours/Yearly (whichever comes first)—Clean and oil the foam air cleaner (more often in dusty, dirty conditions).

1. Wash the foam element in liquid soap and warm water.
2. When the element is clean, rinse it thoroughly.
3. Dry the element by squeezing it in a clean cloth.
4. Put one or two ounces of oil on the element (Figure 48).

Important: Replace the foam element if it is torn or worn.

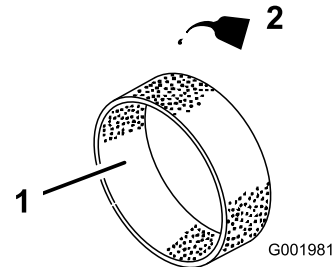

Figure 48

1. Foam element
2. Oil

5. Squeeze the element to distribute the oil.

Checking the Paper Element

Service Interval: Every 100 hours/Yearly (whichever comes first)—Replace the paper air cleaner element (more often in dusty, dirty conditions).

Inspect the paper element for tears, an oily film, damage to the rubber seal, excessive dirt, or other damage (Figure 49). If any of these conditions exist, replace the filter.

Important: Do not clean the paper element with pressurized air or liquids, such as solvent, gas, or kerosene.

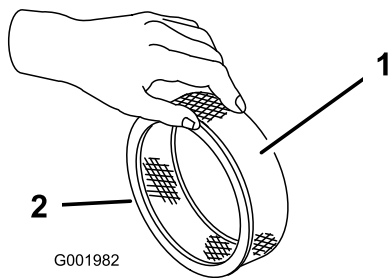

Figure 49

1. Paper element
2. Rubber seal

Important: To prevent engine damage, always operate the engine with the complete foam and paper air cleaner assembly installed.

Installing the Foam and Paper Elements

1. Carefully slide the foam element onto the paper air cleaner element (Figure 47).
2. Slide the air cleaner assembly and cover onto the long rod.
3. Install the cover nut finger-tight against the cover (Figure 47).

Note: Ensure that the rubber seal is flat against the air cleaner base and cover.

4. Install the air cleaner cover and knob (Figure 47).
5. Close and latch the seat.

Servicing the Engine Oil

Crankcase Capacity is 2.1 qt (2.0 l) with the filter.

Use high-quality engine oil that meets the following specifications:

- API classification Level required: SJ, JK, SL, or higher.
- Preferred oil: SAE 10W30 (above 0 degrees F)
- Alternate oil: SAE 5W30 (below 32 degrees F)

Toro Premium Engine Oil is available from your distributor in either 10W30 or 5W30 viscosity. See the *Parts Catalog* for part numbers.

Check the Engine Oil

Service Interval: Before each use or daily

Every 400 hours/Yearly (whichever comes first)

The engine is shipped with oil in the crankcase; however, the level of oil must be checked before you first start the engine and after you have run it.

1. Position the machine on a level surface.
2. Remove the dipstick and wipe it with a clean rag (Figure 50). Insert the dipstick into the tube and make sure it is seated fully. Remove the dipstick and check the oil level.

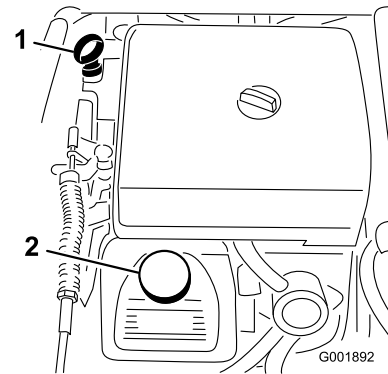

Figure 50

1. Dipstick
2. Filler cap

3. If the oil level is low, remove the filler cap from the valve cover (Figure 50) and pour oil into the opening until the oil level is up to the Full mark on the dipstick. Add the oil slowly and check the level often during this process. Do not overfill.
4. Install the dipstick firmly in place.

Changing the Engine Oil

Service Interval: After the first 50 hours—Change the engine oil.

Every 100 hours—Change the engine oil, including synthetic oil (more often when operating under heavy load or in high temperature).

1. Start the engine and let it run for five minutes. This warms the oil so it drains better.
2. Set the parking brake, stop the pump, stop the engine, and remove the ignition key.
3. Release the latch on the back of the seat and lift the seat forward.

▲ CAUTION

Components under the seat will be hot if the sprayer has been running. If you touch hot components you may be burned.

Allow the sprayer to cool before performing maintenance or touching components under the hood.

4. Place a pan below the oil drain.
5. Remove the drain plug (Figure 51).

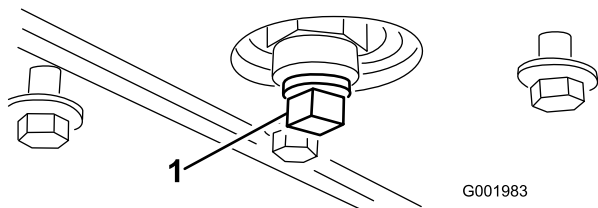

Figure 51

1. Oil drain plug

6. When the oil has drained completely, replace the drain plug and torque it to 10 ft-lb (13.6 N-m).
7. Dispose of the used oil at a certified recycling center.
8. Slowly pour approximately 80% of the specified amount of oil into the oil filler tube (Figure 50).
9. Check the oil level.
10. Slowly add additional oil to bring the oil level to the full mark on the dipstick.

Important: Overfilling the crankcase with oil may cause engine damage.

Changing the Engine Oil Filter

Service Interval: Every 100 hours

1. Drain the oil from the engine; refer to Changing the Engine Oil.
2. Remove the oil filter (Figure 52).

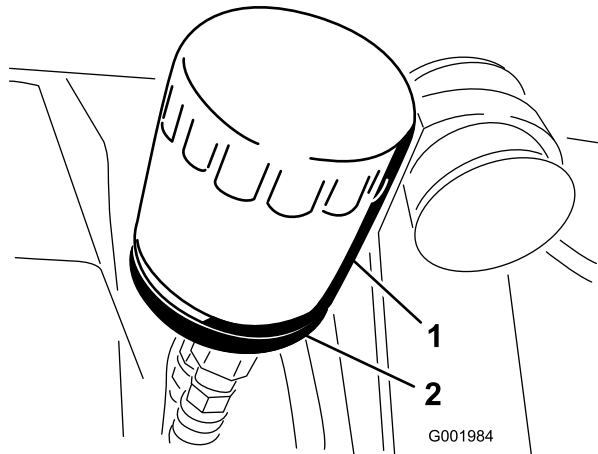

Figure 52

1. Oil filter
2. Filter adapter

3. Wipe the filter adapter gasket surface.
4. Apply a thin coat of new oil to the rubber gasket on the replacement filter.
5. Install the replacement oil filter to the filter adapter. Turn the oil filter clockwise until the rubber gasket contacts the filter adapter, then tighten the filter an additional 1/2 turn (Figure 52).

6. Fill the crankcase with the correct type of new oil; refer to Changing the Engine Oil, steps 8 through 10.
7. Dispose of the used oil filter at a certified recycling center.

Changing the Spark Plugs

Service Interval: Every 200 hours

Type: Champion RC-12YC (or equivalent)

Air Gap: 0.030 inch (0.76 mm)

Make sure the air gap between the center and side electrodes is correct before installing the spark plugs. Use a spark plug wrench for removing and installing the spark plugs and a gapping tool/feeler gauge to check and adjust the air gap.

Removing the Spark Plug

1. Set the parking brake, stop the pump, stop the engine, and remove the ignition key.
2. Release the latch on the back of the seat and lift the seat forward.
3. Pull the wires off the spark plugs (Figure 53).
4. Clean around the spark plugs to prevent dirt from falling into the engine and potentially causing damage.
5. Remove the spark plugs and metal washers.

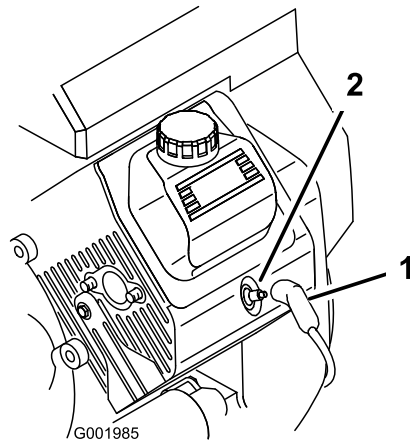

Figure 53

1. Spark plug wire
2. Spark plug

Checking the Spark Plugs

1. Look at the center of the spark plugs (Figure 54).

If you see a light brown or gray coating on the insulator, the engine is operating properly. A black

coating on the insulator usually means the air cleaner is dirty.

Important: Do not clean the spark plugs. Always replace a spark plug when it has a black coating, worn electrodes, an oily film, or cracks.

2. Check the gap between the center and side electrodes (Figure 54) and bend the side electrode, if the gap is not correct.

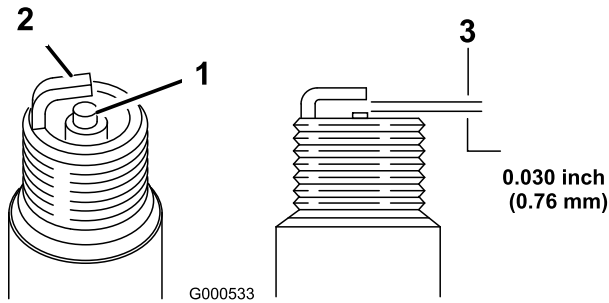

Figure 54

1. Center electrode insulator
2. Side electrode
3. Air gap (not to scale)

Installing the Spark Plugs

1. Install the spark plugs and metal washers.
2. Tighten the spark plugs to 18 to 22 ft-lb (24.4 to 29.8 N-m).
3. Push the wires onto the spark plugs (Figure 53).
4. Close and latch the seat.

Fuel System Maintenance

Replacing the Fuel Filter

Service Interval: Every 100 hours—Replace the fuel filter.

Every 400 hours/Yearly (whichever comes first)—Inspect the fuel lines.

1. Set the parking brake, stop the pump, stop the engine, and remove the ignition key.
2. Release the latch on the back of the seat and lift the seat forward.
3. Clamp off the hose on either side of the fuel filter to prevent gas from pouring out of the hoses when you remove the filter.
4. Place a drain pan under the filter.
5. Squeeze the ends of the hose clamps together and slide them away from the filter (Figure 55).
6. Remove the filter from the fuel lines.

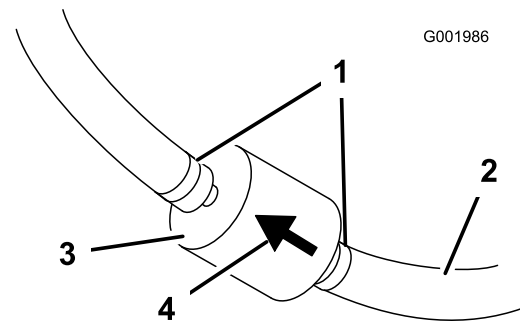

Figure 55

1. Hose clamp
2. Fuel line
3. Filter
4. Flow direction arrow

7. Install a new filter and move the hose clamps close to the filter.

Ensure that the flow direction arrow points toward the engine.

Electrical System Maintenance

Fuses

There are 2 fuse blocks and 1 empty slot in the electrical system. They are located beneath the seat (Figure 56).

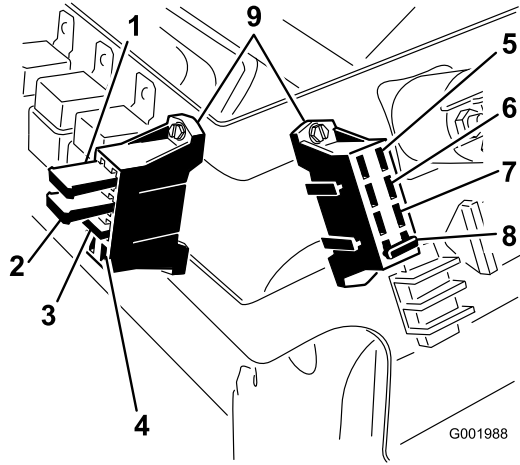

Figure 56

- | | |
|--|-------------------|
| 1. Left boom actuator thermal breaker | 6. Headlights |
| 2. Right boom actuator thermal breaker | 7. Cruise control |
| 3. Foam marker | 8. Spray system |
| 4. Open slot | 9. Fuse blocks |
| 5. Power | |

Servicing the Battery

WARNING

CALIFORNIA Proposition 65 Warning

Battery posts, terminals, and related accessories contain lead and lead compounds, chemicals known to the State of California to cause cancer and reproductive harm. Wash hands after handling.

Important: Do not jump start the sprayer.

Always keep the battery clean and fully charged. Use a paper towel to clean the battery and battery box. If the battery terminals are corroded, clean them with a solution of four parts water and one part baking soda. Apply a light coating of grease to the battery terminals to prevent corrosion.

Voltage: 12 volt with 280 cold cranking Amps @ 0 degrees F

Removing the Battery

1. Position the sprayer on a level surface, set the parking brake, stop the pump, stop the engine, and remove the ignition key.
2. Loosen the knobs on the sides of the battery box and remove the battery cover (Figure 57).

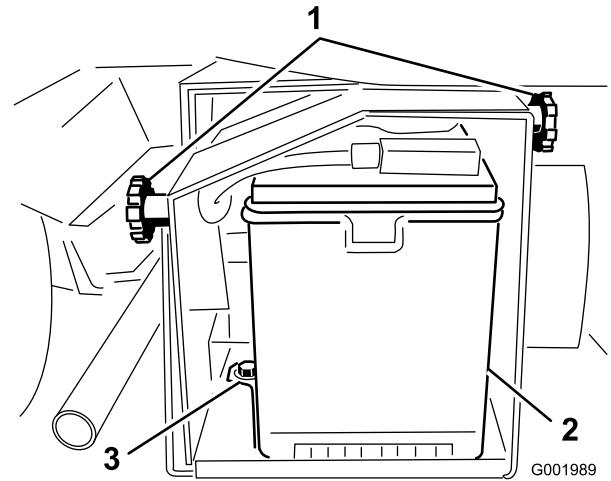

Figure 57

- | | |
|------------|-------------|
| 1. Knobs | 3. Retainer |
| 2. Battery | |

3. Disconnect the negative (black) ground cable from the battery post.

▲ WARNING

Incorrect battery cable routing could damage the sprayer and cables causing sparks. Sparks can cause the battery gasses to explode, resulting in personal injury.

- Always disconnect the negative (black) battery cable before disconnecting the positive (red) cable.
- Always reconnect the positive (red) battery cable before reconnecting the negative (black) cable.

⚠ WARNING

Battery terminals or metal tools could short against metal sprayer components causing sparks. Sparks can cause the battery gasses to explode, resulting in personal injury.

- When removing or installing the battery, do not allow the battery terminals to touch any metal parts of the sprayer.
 - Do not allow metal tools to short between the battery terminals and metal parts of the sprayer.
 - Always keep the battery strap in place to protect and secure the battery.
4. Disconnect the positive (red) cable from the battery post.
 5. Remove the battery retainer and fasteners (Figure 57).
 6. Remove the battery.

Installing the Battery

Service Interval: Every 50 hours—Check the battery cable connections.

1. Set the battery on the battery box so that the battery posts are toward the front of the sprayer.
2. Install the battery retainer and secure it with the fasteners you removed previously (Figure 57).

Important: Always keep the battery retainer in place to protect and secure the battery.

3. Connect the positive (red) cable to the positive (+) battery post and the negative (black) cable to the negative (-) battery post using the bolts and wing nuts. Slide the rubber boot over the positive battery post.
4. Install the battery cover and secure it with the 2 knobs (Figure 57).

Checking the Electrolyte Level

Service Interval: Every 50 hours

Note: When the machine is in storage check the battery electrolyte level every 30 days.

1. Loosen the knobs on the sides of the battery box and remove the battery cover (Figure 57).
2. Remove the filler caps. If the electrolyte is not up to the fill line, add the required amount of distilled water; refer to Adding Water to the Battery.

⚠ DANGER

Battery electrolyte contains sulfuric acid which is a deadly poison and causes severe burns.

- Do not drink electrolyte or allow it to contact your skin, eyes or clothing. Wear safety glasses to shield your eyes and rubber gloves to protect your hands.
- Fill the battery where clean water is always available for flushing the skin.

Adding Water to the Battery

The best time to add distilled water to the battery is just before you operate the machine. This lets the water mix thoroughly with the electrolyte solution.

1. Clean the top of the battery with a paper towel.
2. Remove the filler caps from the battery and slowly fill each cell with distilled water until the level is up to the fill line. Replace the filler caps.

Important: Do not overfill the battery.

Electrolyte will overflow onto other parts of the sprayer and severe corrosion and deterioration will result.

Charging the Battery

Important: Always keep the battery fully charged (1.260 specific gravity). This is especially important to prevent battery damage when the temperature is below 32 degrees F (0 degrees C).

1. Remove the battery from the chassis; refer to Removing the Battery.
2. Check the electrolyte level; refer to Checking the Electrolyte Level.
3. Connect a 3 to 4 amp battery charger to the battery posts. Charge the battery at a rate of 3 to 4 amperes for 4 to 8 hours (12 volts). Do not overcharge the battery.

⚠ WARNING

Charging the battery produces gasses that can explode.

Never smoke near the battery and keep sparks and flames away from battery.

4. Install the battery in the chassis; refer to Installing the Battery.

Storing the Battery

If the machine will be stored for more than 30 days, remove the battery and charge it fully. Either store

it on the shelf or on the machine. Leave the cables disconnected if it is stored on the machine. Store the battery in a cool atmosphere to avoid quick deterioration of the charge in the battery. To prevent the battery from freezing, make sure it is fully charged.

Drive System Maintenance

Maintaining the Primary Drive Clutch

Service Interval: Every 400 hours/Yearly (whichever comes first)—Clean and lubricate the primary drive clutch.

1. Stop the engine, remove the key, and set the parking brake.
2. Raise the front end of the sprayer and support it on jack stands.

⚠ DANGER

A sprayer on a jack may be unstable and slip off of the jack, injuring anyone beneath it.

- Do not start the engine while the sprayer is on a jack.
 - Always remove the key from the ignition before getting off of the sprayer.
 - Block the tires when the sprayer is on a jack.
3. Disconnect the hose located on the lower-front face of the tank (Figure 58).

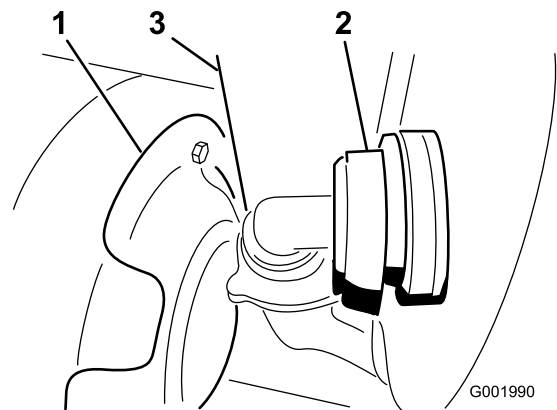

Figure 58

- | | |
|-----------------|----------------|
| 1. Clutch cover | 3. Heat shield |
| 2. Hose | |

4. Remove the 3 bolts securing the cover to the clutch and remove the cover (Figure 59).

Note: You may need to push the heat shield (Figure 58) back as you remove the cover.

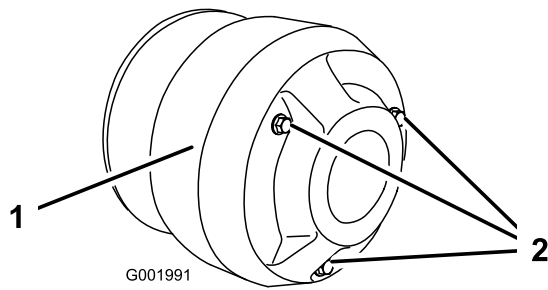

Figure 59

1. Cover 2. Bolts

⚠ CAUTION

The dust in the clutch will become airborne and could damage your eyes or you could inhale it causing breathing difficulties.

Wear safety goggles and a dust mask or other eye and respiratory protection when performing this procedure.

5. Lubricate the moving parts in the areas circled in Figure 60 using Toro Dry Lubricant Spray, available through your Authorized Toro Dealer or Distributor.

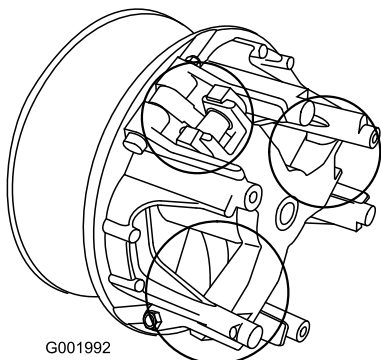

Figure 60

6. Install the clutch cover and secure it with the 3 bolts removed previously.
7. Connect the hose on the front of the tank (Figure 58).

Inspecting the Wheels/Tires

Service Interval: Before each use or daily—Check the tire pressure.

After the first 8 hours—Torque the wheel lug nuts.

Every 100 hours—Torque the wheel lug nuts.

Every 100 hours—Inspect the condition and wear of the tires.

Check the tire pressure every 8 hours or daily to ensure proper levels. Fill the tires to 18 psi (124 kPa). Also, check the tires for wear or damage.

Check the wheels to ensure that they are mounted securely after the first 8 operating hours and then every 100 hours thereafter. Torque the front bolts to 50-55 ft-lb (68-74 N-m) and the rear lug nuts to 40-60 ft-lb (54-81 N-m).

Check the tire condition at least every 100 hours of operation. Operating accidents, such as hitting curbs, can damage a tire or rim and also disrupt wheel alignment, so inspect tire condition after an accident.

Adjusting the Front Wheel Toe-In

Service Interval: Every 100 hours/Yearly (whichever comes first)

The toe-in should be 0 to 1/4 inch (0 to 6 mm).

1. Fill the tank with approximately 80 US gallons (303 L) of water.
2. Check and fill all tires; refer to Checking Tire Pressure.
3. Drive the sprayer back and forth a few times to relax the A-arms, then drive it forward at least 10 ft (3 m).
4. Measure the distance between both of the front tires at the axle height at both the front and rear of the front tires (Figure 61). A fixture or alignment gauge is needed for the rear measurement of the front tires at axle height. Use the same fixture or alignment gauge to accurately measure the front of the front tires at axle height (Figure 61).

The front of the tires should be 0 to 1/4 inch (0 to 6 mm) closer than the back side of the front tires.

Brake Maintenance

Checking the Brake Fluid

The brake fluid reservoir is shipped from the factory filled with DOT 3 brake fluid. Check the level before starting the engine each day.

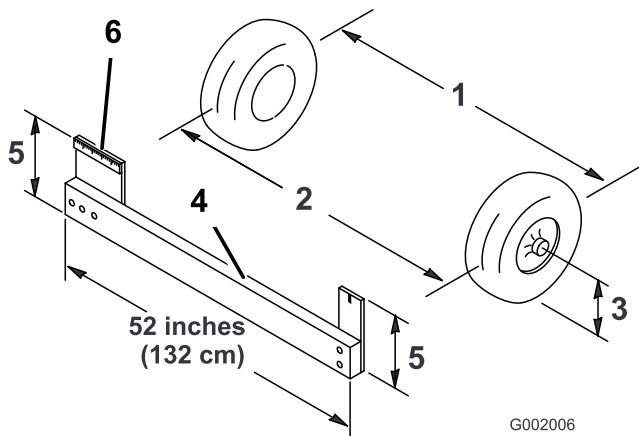

Figure 61

1. Tire center line-back
2. Tire center line-front
3. Axle center line
4. Fixture
5. Axle center line distance
6. 6 inches (15 cm) ruler

5. If the measurement does not fall within the specified range, loosen the jam nuts at both ends of the tie rods (Figure 62).

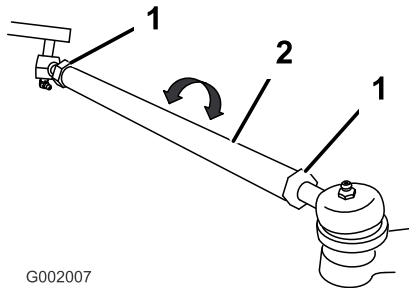

Figure 62

1. Jam nut
2. Tie rod

6. Rotate both tie rods to move the front of the tire inward or outward.

Note: The tie rods should be the same length when you are finished.

7. Tighten the tie rod jam nuts when the adjustment is correct.
8. Ensure that there is full travel of the steering wheel in both directions.

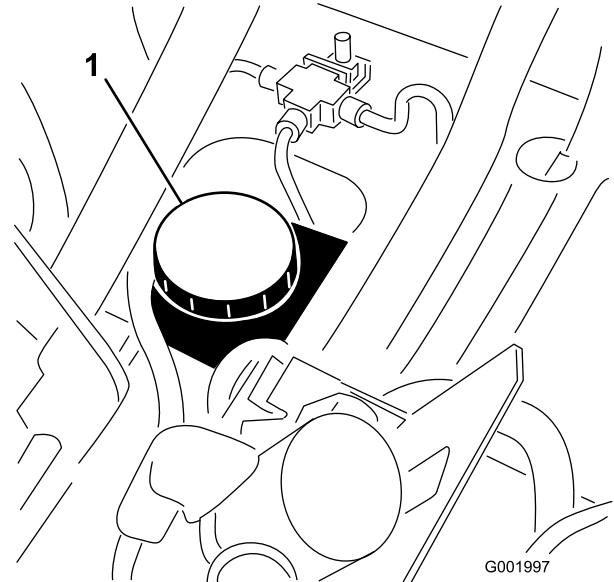

Figure 63

1. Brake fluid reservoir

1. Position the sprayer on a level surface, set the parking brake, stop the pump, stop the engine, and remove the ignition key.
2. The fluid level should be up to the Full line on the reservoir (Figure 64).

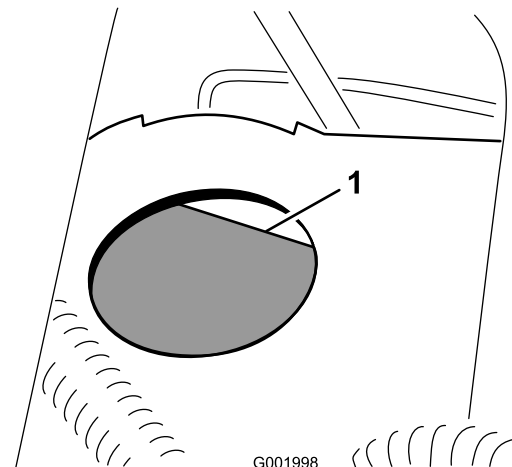

Figure 64

1. Full line

3. If the fluid level is low, clean the area around the reservoir cap, remove the cap, and fill the reservoir to the proper level. Do not overfill.

Inspecting the Brakes

Service Interval: Every 100 hours

The brakes are a critical safety component of the sprayer. Inspect them as follows:

- Inspect the brake shoes for wear or damage. If the lining (brake pad) thickness is less than 1/16 inch (1.6 mm), replace the brake shoes.
- Inspect the backing plate and other components for signs of excessive wear or deformation. If any deformation is found, replace the appropriate components.

Adjusting the Parking Brake

Service Interval: Every 200 hours—Check the parking brake.

1. Loosen the set screw securing the knob to the parking brake lever (Figure 65).

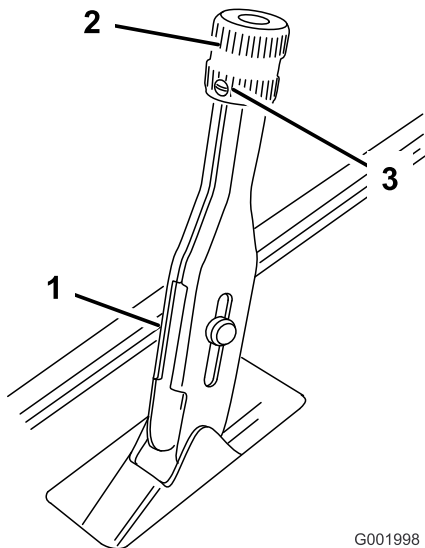

Figure 65

1. Parking brake lever
2. Knob
3. Set screw

2. Rotate the knob until a force of 35-45 lb is required to actuate lever.
3. Tighten the set screw.

Belt Maintenance

Servicing the Drive Belt

Checking the Drive Belt

Service Interval: After the first 8 hours
Every 200 hours

1. Position the sprayer on a level surface, set the parking brake, move the range selector to the Neutral position, stop the pump, stop the engine, and remove the ignition key.
2. Rotate and inspect the drive belt for excessive wear or damage. Replace the belt if necessary.

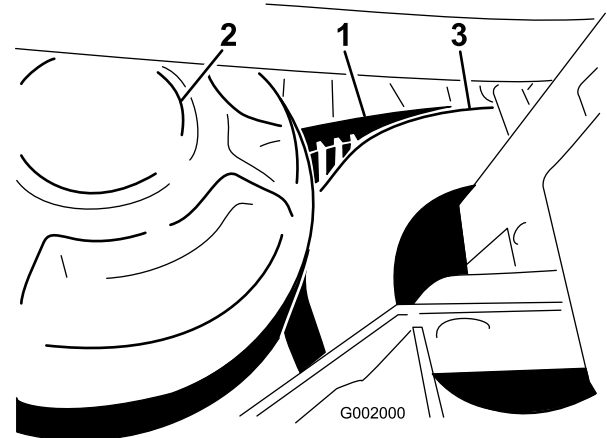

Figure 66

1. Drive belt
2. Primary clutch
3. Secondary clutch

Replacing the Drive Belt

1. Rotate and route the belt over the secondary clutch (Figure 66).
2. Remove the belt from the primary clutch.
3. Place the new belt over the primary clutch.
4. Rotate and install it over the secondary clutch.

Adjusting the Steering Pump Belt

Service Interval: After the first 8 hours
Every 100 hours

The belt should flex 1/4 inch (5 mm) when 5 lb of force (22 N) is applied midway on the top span.

1. Park the machine on a level surface, set the parking brake, turn the ignition off, and remove the key.
2. Loosen the steering pump mounting bolts (Figure 67).

Hydraulic System Maintenance

Checking the Transaxle/Hydraulic Fluid

Service Interval: Every 200 hours

1. Position the sprayer on a level surface, set the parking brake, stop the pump, stop the engine, and remove the ignition key.
2. Remove the transaxle dipstick and wipe it with a clean rag (Figure 68).

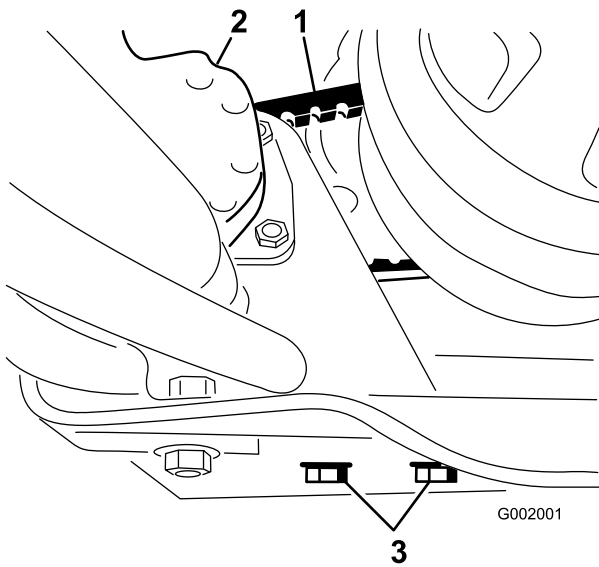

Figure 67

1. Steering pump belt
2. Steering pump
3. Steering pump mounting bolts

3. Move the pump until the belt flexes 1/4 inch (5 mm) with 5 lb. of force (22 N) then tighten the mounting bolts, starting with the bolt closest to the engine crankshaft.

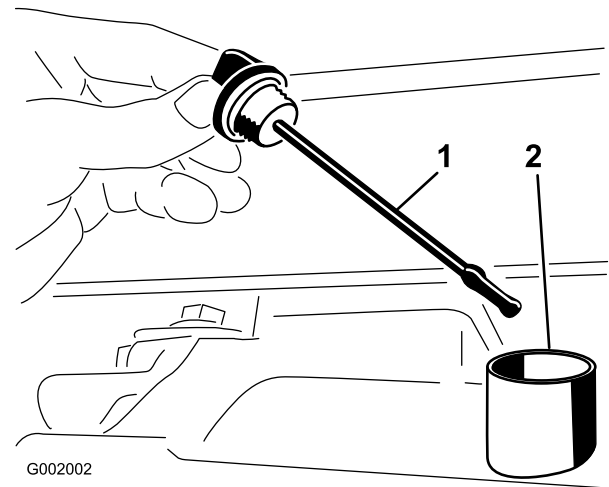

Figure 68

1. Dipstick
2. Fill hole

Important: Be very careful not to get dirt or other contaminants into the opening when checking the transmission oil.

3. Insert the dipstick into the tube and make sure it is seated fully. Remove the dipstick and check the oil level.
4. The transaxle fluid level should be at the top of the flat portion of the dipstick. If it is not, fill the reservoir with the appropriate fluid; refer to Changing the Transaxle/Hydraulic Fluid.
5. Install the dipstick firmly in place.

Changing Transaxle/Hydraulic Fluid

Service Interval: Every 800 hours/Yearly (whichever comes first)

1. Position the sprayer on a level surface, set the parking brake, stop the pump, stop the engine, and remove the ignition key.

- Place a drain pan under the drain plug of the reservoir.
- Remove the drain plug from the side of the reservoir and let the hydraulic fluid flow into the drain pan (Figure 69).

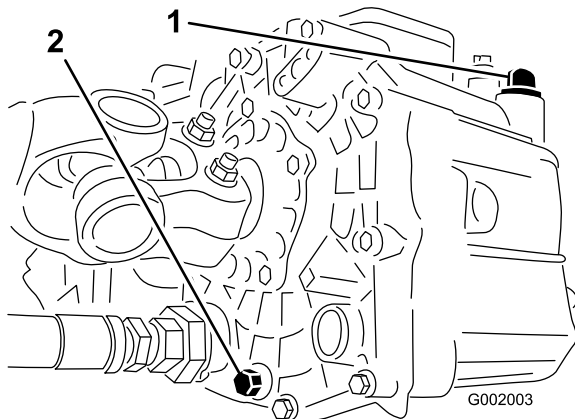

Figure 69

- Hydraulic dipstick
- Drain plug

- Note the orientation of the hydraulic hose and 90 degrees fitting connected to the strainer.
- Remove the hydraulic hose and 90 degrees fitting (Figure 70).

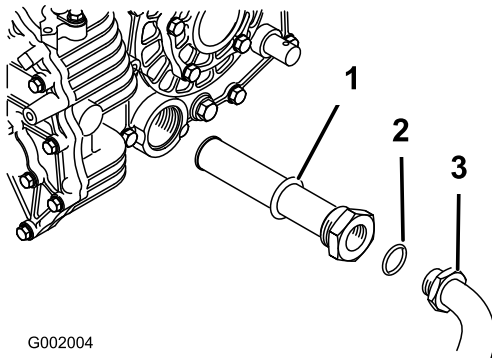

Figure 70

- Hydraulic strainer
- O-ring
- 90 degrees fitting

- Remove the strainer and clean it by back flushing it with a clean degreaser.
- Allow the strainer to air dry.
- Install the strainer when the oil is draining.
- Install the hydraulic hose and 90 degrees fitting to the strainer.
- Install and tighten the drain plug.
- Fill the reservoir with approximately 7.5 qt. of Dexron III ATF.

Important: Use only the hydraulic fluids specified. Other fluids could cause system damage.

- Start the engine and drive the sprayer to fill the hydraulic system. Recheck the oil level and replenish it, if required.

Replacing the Hydraulic Filter

Service Interval: After the first 8 hours

Every 800 hours/Yearly (whichever comes first)

Use the Toro replacement filter (Part No. 54-0110).

Important: Use of any other filter may void the warranty on some components.

- Position the sprayer on a level surface, set the parking brake, stop the pump, stop the engine, and remove the ignition key.
- Clean the area around the filter mounting area.
- Place a drain pan under the filter.
- Remove the filter (Figure 71).

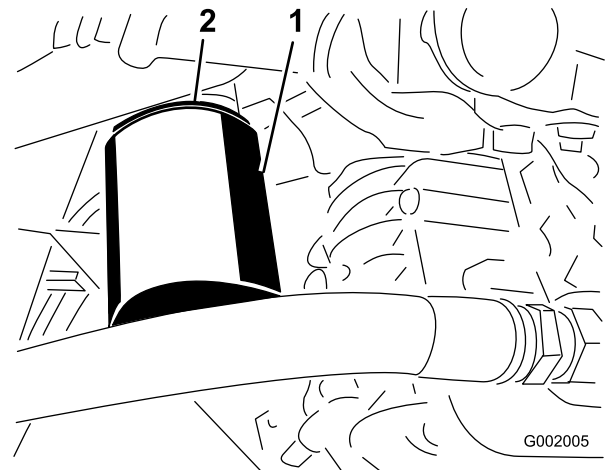

Figure 71

- Hydraulic filter
- Gasket

- Lubricate the new filter gasket.
- Ensure that the filter mounting area is clean.
- Screw the filter on until the gasket contacts the mounting plate, then tighten the filter one-half turn.
- Start the engine and let it run for about two minutes to purge air from the system. Stop the engine and check the hydraulic oil level and for leaks.

Spray System Maintenance

⚠ WARNING

Chemical substances used in the spray system may be hazardous and toxic to you, bystanders, animals, plants, soils or other property.

- Carefully read and follow the chemical warning labels and Material Safety Data Sheets (MSDS) for all chemicals used and protect yourself according to the chemical manufacturer's recommendations. For example, use appropriate Personal Protective Equipment (PPE) including face and eye protection, gloves, or other equipment to guard against personal contact with the chemical.
- Keep in mind that there may be more than one chemical used and information on each should be assessed.
- *Refuse to operate or work on the sprayer if this information is not available!*
- Before working on a spray system make sure the system has been triple rinsed and neutralized according to the recommendations of the chemical manufacturer(s).
- Verify there is an adequate supply of clean water and soap nearby, and immediately wash off any chemicals that contact you.

Inspecting the Hoses

Service Interval: Every 200 hours—Inspect all hoses and connections for damage and proper attachment.

Examine each hose in the spray system for cracks, leaks or other damage. At the same time, inspect the connections and fittings for similar damage. Replace any hoses and fittings if damaged.

Pump Maintenance

Inspecting the Pump

Service Interval: Every 400 hours/Yearly (whichever comes first)—Inspect the pump diaphragm and replace if necessary. (see an Authorized Toro Service Distributor)

Every 400 hours/Yearly (whichever comes first)—Inspect the pressure

dampener bladder and replace if necessary. (see an Authorized Toro Service Distributor)

Every 400 hours/Yearly (whichever comes first)—Inspect the pump check valves and replace if necessary. (see an Authorized Toro Service Distributor)

Note: The following machine components are considered parts subject to consumption through use unless found defective and are not covered by the Warranty associated with this machine.

Have an Authorized Toro Service Distributor check following internal pump components for damage:

- Pump diaphragm
- Pressure dampener bladder
- Pump check valves assemblies

Replace any components if necessary.

Adjusting the Air Pressure in Dampener

The air pressure in the dampener on the pump is set at 15 psi (1 bar) by the manufacturer. The recommended pressure in the dampener is 1/3 of the spraying pressure. If using a spray pressure greater than 45 psi (3.1 bar) adjust the dampener accordingly.

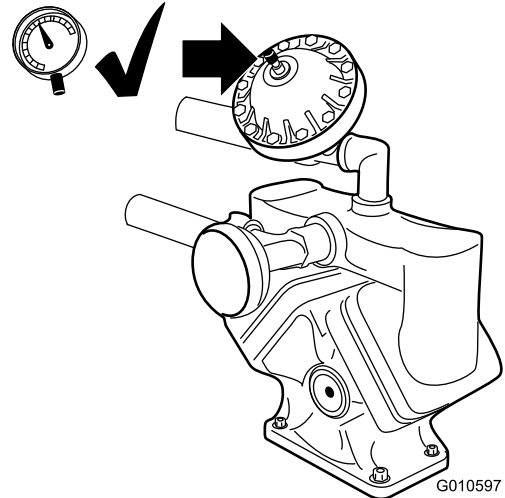

Figure 72

Changing the Pump Drive Gearbox Fluid

Service Interval: Every 400 hours/Yearly (whichever comes first)

1. Position the sprayer on a level surface, set the parking brake, stop the pump, stop the engine, and remove the ignition key.

- Place a pan under the drain plug on the pump drive gear box (Figure 73).

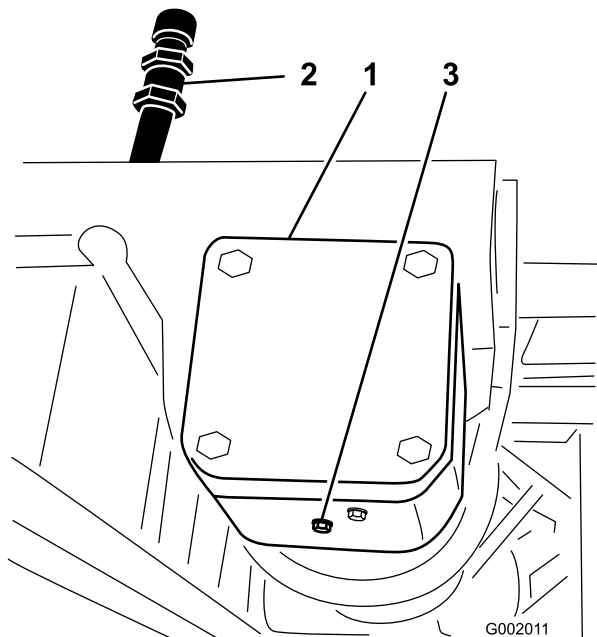

Figure 73

- | | |
|-----------------------|---------------|
| 1. Pump drive gearbox | 3. Drain plug |
| 2. Fill tube | |

- Remove the fill plug and drain plug (Figure 73), allowing the oil to drain into the pan.
- Install and tighten the drain plug when the fluid stops draining.
- Add approximately 1 quart (1 L) of Mobil SHC 634 Synthetic Lubricant to the fill tube.

Important: Use only Mobil SHC 634 Synthetic Lubricant or equivalent synthetic fluid in the gear box. Non-synthetic oils may break down causing damage to the pump gearbox.

- Install the fill plug.

Adjusting the Boom Actuator

Service Interval: Every 400 hours—Check boom actuator hydraulic oil for air bubbles.

- Position the sprayer on a level surface, lower the booms into the spray position.
- Set the parking brake, stop the pump, stop the engine, and remove the ignition key
- Attempt to lift the boom by applying a moderate amount of pressure (just enough to lift the boom manually) while observing the actuator rod. If the actuator rod exhibits movement refer to below.
- Repeat the procedure for the opposing boom.

If the actuator rod exhibits an axial movement (travels into or out of the cylinder) greater than 0.085-0.100 inch (2.16-2.54 mm), you may wish to bleed the air from the hydraulic oil.

Refer to the *Service Manual* for instructions on how to bleed air from the actuators or contact an Authorized Toro Service Distributor.

Emergency Manual Operation of the Boom Actuators

Note: Determine the left and right sides of the machine from the normal operating position.

⚠ DANGER

Use of the manual relief valve may cause the boom to move suddenly and cause injury to you or others.

- Take caution and adjust the manual relief valve slowly.
- Ensure the surrounding area is clear and no one is inside the operating range of the boom.

⚠ CAUTION

Adjusting the manual relief valve with electrical power present could cause the actuator operate irregularly and cause injury to you or others.

Do not use the manual relief valve while electrical power is being supplied to the actuator.

In case of an emergency such that the boom must be moved and no 12V DC power source is available, the manual relief valve can be used to relieve pressure within the actuator and allow the booms to be moved manually.

Important: The manual valve must not be loosened more than 4 turns. Turning the valve more than 4 turns may cause the valve to come off completely allowing hydraulic oil to spill out.

- Locate the manual relief valve on the actuator for each boom. The manual relief valve is the smaller valve and is only on one side of the actuator body (Figure 74).

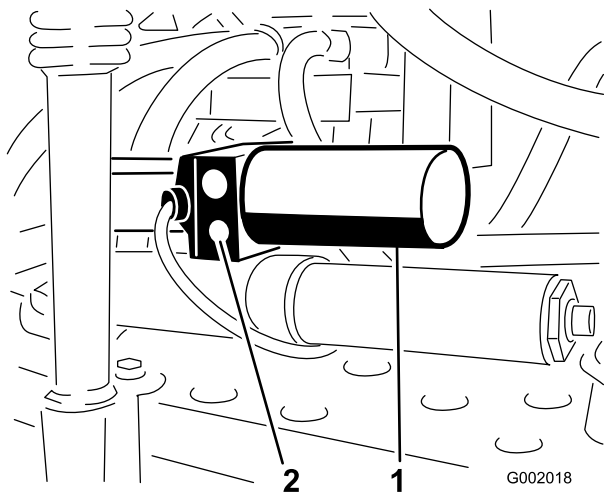

Figure 74

1. Actuator, right boom
2. Manual relief valve

Note: Due to the opposing orientation of actuators in respect to each other the manual relief valve is on the forward face of the left boom actuator and the rear face of the right boom actuator.

2. Use a hexagonal wrench to loosen the manual relief valve **no more** than 2-3 turns. The cylinder should start stroking manually or by external pressure at this time.
3. Once the original position of the actuator is recovered, close the manual relief valve. Torque the valve to 1.1-2.1 ft-lb (1.5-2.9 N-m).

Inspecting the Nylon Pivot Bushings

Service Interval: Every 400 hours/Yearly (whichever comes first)

1. Position the sprayer on a level surface, set the parking brake, stop the pump, stop the engine, and remove the ignition key.
2. Extend the booms to the spray position and support the booms using stands or straps from a lift.
3. With the weight of the boom supported, remove the bolt and nut securing the pivot pin to the boom assembly (Figure 75). Remove the pivot pin.

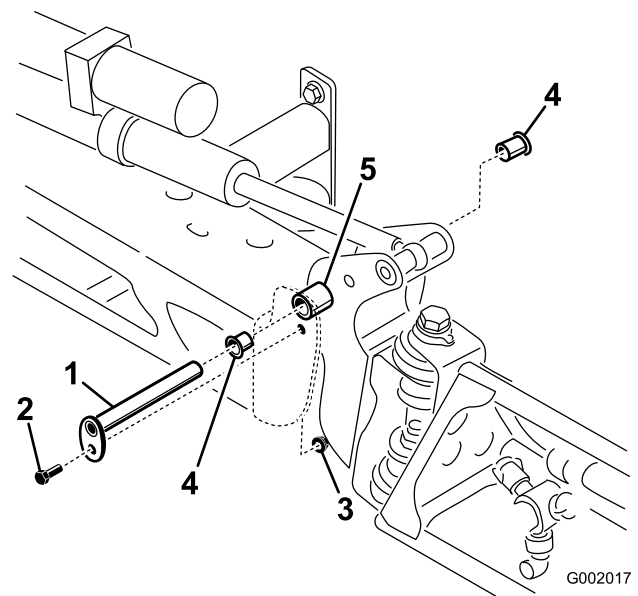

Figure 75

1. Pivot pin
2. Bolt
3. Nut
4. Nylon bushing
5. Pivot bracket

4. Remove the boom and pivot bracket assembly from the center frame to access the nylon bushings.
5. Remove and inspect the nylon bushings from the front and back sides of the pivot bracket (Figure 75). Replace any damaged bushings.
6. Place a small amount of oil on the nylon bushings and install them into pivot bracket.
7. Install the boom and pivot bracket assembly into the center frame, aligning the openings (Figure 75).
8. Install the pivot pin and secure it with the bolt and nut removed previously.

Repeat the procedure for each boom.

Cleaning

Cleaning the Flowmeter

Service Interval: Every 400 hours/Yearly (whichever comes first)

Occasionally, the flowmeter may need to be cleaned to remove an obstruction.

Note: Make sure the pump is off when performing this procedure.

1. Disconnect the flowmeter wire from wiring harness.
2. Remove the retaining cap from the flowmeter body (Figure 76).

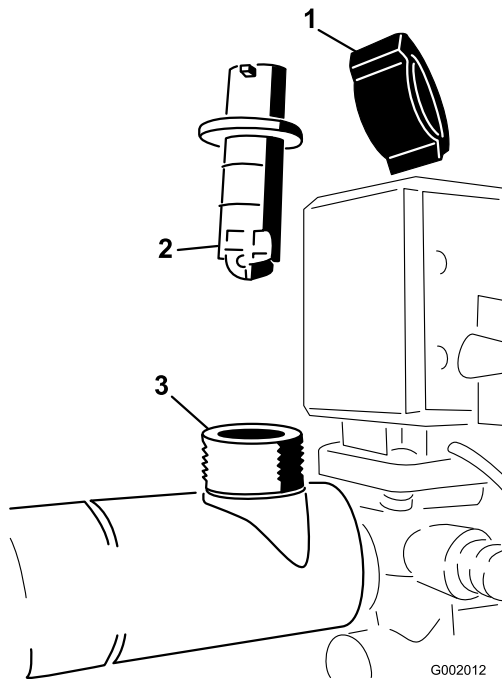

Figure 76

1. Retaining cap
2. Paddle wheel assembly
3. Flowmeter body

wheel assembly into the body in any other orientation.

6. Install the retaining cap.
7. Connect the wire to the flowmeter.

Cleaning the Suction Strainer

Service Interval: Before each use or daily (more often when using wettable powders)

1. Remove the retainer from the red fitting attached to the large hose on the top of the tank.

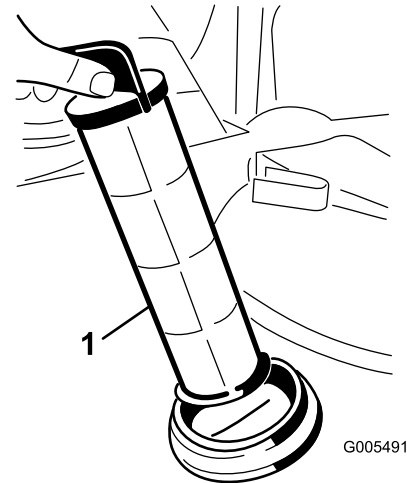

Figure 77

1. Suction strainer

3. Carefully pull the paddle wheel assembly from the body.
4. Use warm water, a soft-bristled brush, and a mild detergent as necessary to clean the flowmeter body and paddle wheel. Remove any small metallic debris.

Important: Do not use solvents or fuel to clean the flowmeter.

5. Install the paddle wheel assembly into the flowmeter body.

Important: The paddle wheel assembly will only fit into the body one way, in a detent slot on the side of the body. Do not force the paddle

2. Disconnect the hose from the tank.
3. Pull the strainer out of the hole.
4. Clean the strainer with clean running water.
5. Replace the strainer, seating it fully into the hole.
6. Connect the hose to the top of the tank and secure it with the retainer.

Storage

1. Position the sprayer on a level surface, set the parking brake, stop the pump, stop the engine, and remove the ignition key.
2. Clean dirt and grime from the entire machine, including the outside of the engine's cylinder head fins and blower housing.

Important: You can wash the machine with mild detergent and water. Do not use high pressure water to wash the machine. Pressure washing may damage the electrical system or wash away necessary grease at friction points. Avoid excessive use of water, especially near the control panel, lights, engine, and the battery.

3. Clean the spray system; refer to the Cleaning the Sprayer section in Operation.
4. Add a rust inhibiting, non-alcohol based, RV antifreeze solution to the system and run the pump for a few minutes to circulate it through the system, then drain the spray system as completely as possible.
5. Use the boom lift switches to raise the booms. Raise the booms until they have moved completely into boom transport cradle forming the "X" transport position and the boom cylinders are fully retracted. Make sure the boom cylinders are fully retracted to prevent actuator rod damage.
6. Inspect the brakes; refer to Inspecting the Brakes in the Brake Maintenance section.
7. Service the air cleaner; refer to Servicing the Air Cleaner in the Engine Maintenance section.
8. Grease the sprayer; refer to the Lubrication section.
9. Change the crankcase oil; refer to Servicing Engine Oil in the Engine Maintenance section.
10. Check the tire pressure; refer to Checking the Tire Pressure in the Drive System Maintenance section.
11. For storage over 30 days, prepare the fuel system as follows:

- A. Add a petroleum based stabilizer/conditioner to fuel in the tank.

Follow mixing instructions from stabilizer manufacturer. (1 oz. per gallon). Do not use an alcohol based stabilizer (ethanol or methanol).

Note: A fuel stabilizer/conditioner is most effective when mixed with fresh gasoline and used at all times.

- B. Run the engine to distribute conditioned fuel through the fuel system (5 minutes).

- C. Stop the engine, allow it to cool, and drain the fuel tank.
- D. Restart the engine and run it until it stops.
- E. Choke the engine.
- F. Start and run the engine until it will not start again.
- G. Dispose of fuel properly. Recycle as per local codes.

Important: Do not store stabilizer/conditioned gasoline over 90 days

12. Remove the spark plugs and check their condition; refer to Changing Spark Plugs in the Engine Maintenance section.
13. With the spark plugs removed from the engine, pour two tablespoons of engine oil into the spark plug hole.
14. Use the electric starter to crank the engine and distribute the oil inside the cylinder.
15. Install the spark plugs and tighten to recommended torque; refer to Changing Spark Plugs in the Engine Maintenance section.

Note: Do not install the wire on the spark plug(s).

16. Remove the battery from the chassis, check the electrolyte level, and charge it fully; refer to Servicing the Battery in the Electrical System Maintenance section.

Note: Do not connect the battery cables to the battery posts during storage.

Important: The battery must be fully charged to prevent it from freezing and being damaged at temperatures below 32 degreesF (0 degreesC). A fully charged battery maintains its charge for about 50 days at temperatures lower than 40 degreesF (4 degreesC). If the temperatures will be above 40 degreesF (4 degreesC), check the water level in the battery and charge it every 30 days.

17. Check and tighten all bolts, nuts, and screws. Repair or replace any part that is damaged.
18. Check the condition of all spray hoses, replacing any that are damaged or worn.
19. Tighten all hose fittings.
20. Paint all scratched or bare metal surfaces.

Paint is available from your Authorized Service Dealer.

21. Store the machine in a clean, dry garage or storage area.
22. Remove the ignition key and put it in a safe place out of the reach of children.
23. Cover the machine to protect it and keep it clean.

Troubleshooting

Troubleshooting the Engine and Vehicle

Problem	Possible Cause	Corrective Action
The starter does not crank.	<ol style="list-style-type: none"> 1. The range selector is in a gear other than Neutral. 2. The electrical connections are corroded or loose. 3. A fuse is blown or loose. 4. The battery is discharged. 5. The safety interlock system is malfunctioning. 6. A broken starter or starter solenoid. 7. Seized internal engine components. 	<ol style="list-style-type: none"> 1. Press the brake pedal and move the range selector to the Neutral position. 2. Check the electrical connections for good contact. 3. Correct or replace fuse. 4. Charge or replace the battery. 5. Contact your Authorized Service Dealer. 6. Contact your Authorized Service Dealer. 7. Contact your Authorized Service Dealer.
The engine cranks, but will not start.	<ol style="list-style-type: none"> 1. The fuel tank is empty. 2. Dirt, water, or stale fuel is in the fuel system. 3. Clogged fuel line. 4. The spark plug lead is disconnected. 5. A spark plug is damaged or dirty. 6. The kill relay is not energized. 7. The ignition is broken. 	<ol style="list-style-type: none"> 1. Fill with fresh fuel. 2. Drain and flush the fuel system; add fresh fuel. 3. Clean or replace. 4. Reconnect the spark plug. 5. Replace the spark plug. 6. Contact your Authorized Service Dealer. 7. Contact your Authorized Service Dealer.
The engine starts, but does not keep running.	<ol style="list-style-type: none"> 1. The fuel tank vent is restricted. 2. Dirt or water in the fuel system. 3. The fuel filter is clogged. 4. A fuse is blown or loose. 5. The fuel pump is broken. 6. The carburetor is broken. 7. Loose wires or poor connections. 8. The cylinder head gasket is broken. 	<ol style="list-style-type: none"> 1. Replace the fuel cap. 2. Drain and flush the fuel system; add fresh fuel. 3. Replace the fuel filter. 4. Correct or replace fuse. 5. Contact your Authorized Service Dealer. 6. Contact your Authorized Service Dealer. 7. Check and tighten wire connections. 8. Contact your Authorized Service Dealer.
The engine runs, but knocks or misses.	<ol style="list-style-type: none"> 1. Dirt, water, or stale fuel is in the fuel system. 2. A spark plug lead is loose. 3. A spark plug is broken. 4. Loose wires or poor connections. 5. Engine overheating. 	<ol style="list-style-type: none"> 1. Drain and flush the fuel system; add fresh fuel. 2. Reconnect the spark plug lead. 3. Replace the spark plug. 4. Check and tighten wire connections. 5. See Engine Overheats.

Problem	Possible Cause	Corrective Action
The engine will not idle.	<ol style="list-style-type: none"> 1. The fuel tank vent is restricted. 2. Dirt, water, or stale fuel is in the fuel system. 3. A spark plug is damaged or broken. 4. Carburetor idle passages are plugged. 5. The idle speed adjusting screw is incorrectly set. 6. The fuel pump is broken. 7. Low compression. 8. The air cleaner element is dirty. 	<ol style="list-style-type: none"> 1. Replace the fuel cap. 2. Drain and flush the fuel system; add fresh fuel. 3. Replace the spark plug. 4. Contact your Authorized Service Dealer. 5. Contact your Authorized Service Dealer. 6. Contact your Authorized Service Dealer. 7. Contact your Authorized Service Dealer. 8. Clean or replace.
The engine overheats.	<ol style="list-style-type: none"> 1. The crankcase oil level is incorrect. 2. Excessive loading. 3. The air intake screens are dirty. 4. The cooling fins and air passages under the engine blower housing and/or the rotating air intake screen are plugged. 5. The fuel mixture is lean. 	<ol style="list-style-type: none"> 1. Fill or drain to the full mark. 2. Reduce load; use lower ground speed. 3. Clean with every use. 4. Clean with every use. 5. Contact your Authorized Service Dealer.
The engine loses power.	<ol style="list-style-type: none"> 1. The crankcase oil level is incorrect. 2. The air cleaner element is dirty. 3. Dirt, water, or stale fuel is in the fuel system. 4. The engine is overheated. 5. A spark plug is damaged or dirty. 6. The vent hole in the fuel tank vent fitting is plugged. 7. Low compression. 	<ol style="list-style-type: none"> 1. Fill or drain to the full mark. 2. Clean or replace. 3. Drain and flush the fuel system; add fresh fuel. 4. See Engine Overheats. 5. Replace the spark plug. 6. Replace the fuel cap. 7. Contact your Authorized Service Dealer.
Abnormal vibration or noise.	<ol style="list-style-type: none"> 1. The engine mounting bolts are loose. 2. There is a problem with the engine. 	<ol style="list-style-type: none"> 1. Tighten the engine mounting bolts. 2. Contact your Authorized Service Dealer.
The machine will not operate or is sluggish in either direction because the engine bogs down or stalls.	<ol style="list-style-type: none"> 1. The parking brake is set. 	<ol style="list-style-type: none"> 1. Release the parking brake.
The machine will not operate in either direction.	<ol style="list-style-type: none"> 1. The range selector is in the Neutral position. 2. The parking brake was not released or the parking brake is not releasing. 3. The transmission is broken. 4. The control linkage needs adjustment or replacement. 5. The drive shaft or wheel hub key has been damaged. 	<ol style="list-style-type: none"> 1. Press the brake and shift the range selector into a gear. 2. Release the parking brake or check the linkage. 3. Contact your Authorized Service Dealer. 4. Contact your Authorized Service Dealer. 5. Contact your Authorized Service Dealer.

Troubleshooting the Spray System

Problem	Possible Cause	Corrective Action
A boom section does not spray.	<ol style="list-style-type: none"> 1. The electrical connection on the boom valve is dirty or disconnected. 2. Blown fuse 3. Pinched hose 4. A boom by-pass valve is improperly adjusted. 5. Damaged boom valve 6. Damaged electrical system 	<ol style="list-style-type: none"> 1. Turn the valve off manually. Disconnect the electrical connector on the valve and clean all leads, then reconnect it. 2. Check the fuses and replace them as necessary. 3. Repair or replace the hose. 4. Adjust the boom by-pass valves. 5. Contact your Authorized Service Dealer. 6. Contact your Authorized Service Dealer.
A boom section does not turn off.	<ol style="list-style-type: none"> 1. The valve is damaged. 	<ol style="list-style-type: none"> 1. Stop the spray system and pump and turn off the sprayer. Remove the retainer from under the boom valve and pull out the motor and stem. Inspect all parts and replace any that appear damaged.
A boom valve is leaking	<ol style="list-style-type: none"> 1. An O-ring is deteriorated. 	<ol style="list-style-type: none"> 1. Stop the spray system and pump and turn off the sprayer. Disassemble the valve and replace the O-rings.
A pressure drop occurs when you turn on a boom.	<ol style="list-style-type: none"> 1. The boom bypass valve is improperly adjusted. 2. There is an obstruction in the boom valve body. 3. A nozzle filter is damaged or clogged. 	<ol style="list-style-type: none"> 1. Adjust the boom bypass valve. 2. Remove the inlet and outlet connections to the boom valve and remove any obstructions. 3. Remove and inspect all nozzles.
Boom actuator is not operating properly.	<ol style="list-style-type: none"> 1. A thermal breaker in the fuse block responsible for powering the actuator has tripped due to overheating. 2. A thermal breaker in the boom actuator responsible for powering the actuator has tripped or malfunctioned. 	<ol style="list-style-type: none"> 1. Wait for the system to cool down before resuming operation. If the thermal breakers trip repeatedly, contact your Authorized Service Dealer. 2. Contact your Authorized Service Dealer.

Troubleshooting the Spray Pro Monitor

Problem	Possible Cause	Corrective Action
The monitor does not function.	<ol style="list-style-type: none"> 1. The monitor cable is loose or disconnected. 2. The monitor or cable is damaged. 	<ol style="list-style-type: none"> 1. Connect the monitor cable. 2. Contact your Authorized Service Dealer.
The Speed is always 0 or erratic.	<ol style="list-style-type: none"> 1. The monitor cable is loose. 2. The speed sensor is not calibrated correctly. 3. The speed sensor is damaged. 	<ol style="list-style-type: none"> 1. Connect the monitor cable. 2. Calibrate the speed sensor. 3. Contact your Authorized Service Dealer.
The Area is inaccurate.	<ol style="list-style-type: none"> 1. The sprayer width is not correctly entered. 2. The speed sensor is not calibrated correctly. 3. The speed sensor is damaged. 	<ol style="list-style-type: none"> 1. Check and set the appropriate Width in the calibration mode. 2. Calibrate the speed sensor. 3. Contact your Authorized Service Dealer.

Problem	Possible Cause	Corrective Action
The Distance is inaccurate.	<ol style="list-style-type: none"> 1. The speed sensor is not calibrated correctly. 2. The speed sensor is damaged. 	<ol style="list-style-type: none"> 1. Calibrate the speed sensor. 2. Contact your Authorized Service Dealer.
The monitor does not display Application Rate or Total Volume.	<ol style="list-style-type: none"> 1. The monitor cable is loose. 2. The flow meter is dirty or clogged. 3. The flow meter is not calibrated correctly. 4. The flow meter is damaged. 	<ol style="list-style-type: none"> 1. Connect the monitor cable. 2. Clean the flow meter. 3. Calibrate the flow meter. 4. Contact your Authorized Service Dealer.
The Total Volume is inaccurate.	<ol style="list-style-type: none"> 1. The flow meter is dirty or clogged. 2. The flow meter is not calibrated correctly. 3. The flow meter is damaged. 	<ol style="list-style-type: none"> 1. Clean the flow meter. 2. Calibrate the flow meter. 3. Contact your Authorized Service Dealer.
The monitor displays 6553.5 when in the Application Rate setting.	<ol style="list-style-type: none"> 1. The monitor is not receiving data from the speed sensor. 	<ol style="list-style-type: none"> 1. Contact your Authorized Service Dealer.
The monitor is erratic in operation.	<ol style="list-style-type: none"> 1. A two-way radio is too close to the monitor or its cables. 	<ol style="list-style-type: none"> 1. Keep two-way radios away from the monitor and its cables.
The displayed measurements do not make sense.	<ol style="list-style-type: none"> 1. The Units of Measurement is set to a system other than what you expect. 	<ol style="list-style-type: none"> 1. Check the Units of Measurement to ensure that it is set correctly.
The monitor reads "OFL."	<ol style="list-style-type: none"> 1. The data has exceeded the maximum allowed. 	<ol style="list-style-type: none"> 1. Press and hold the [Reset] button to clear the monitor.

Schematics

G002328

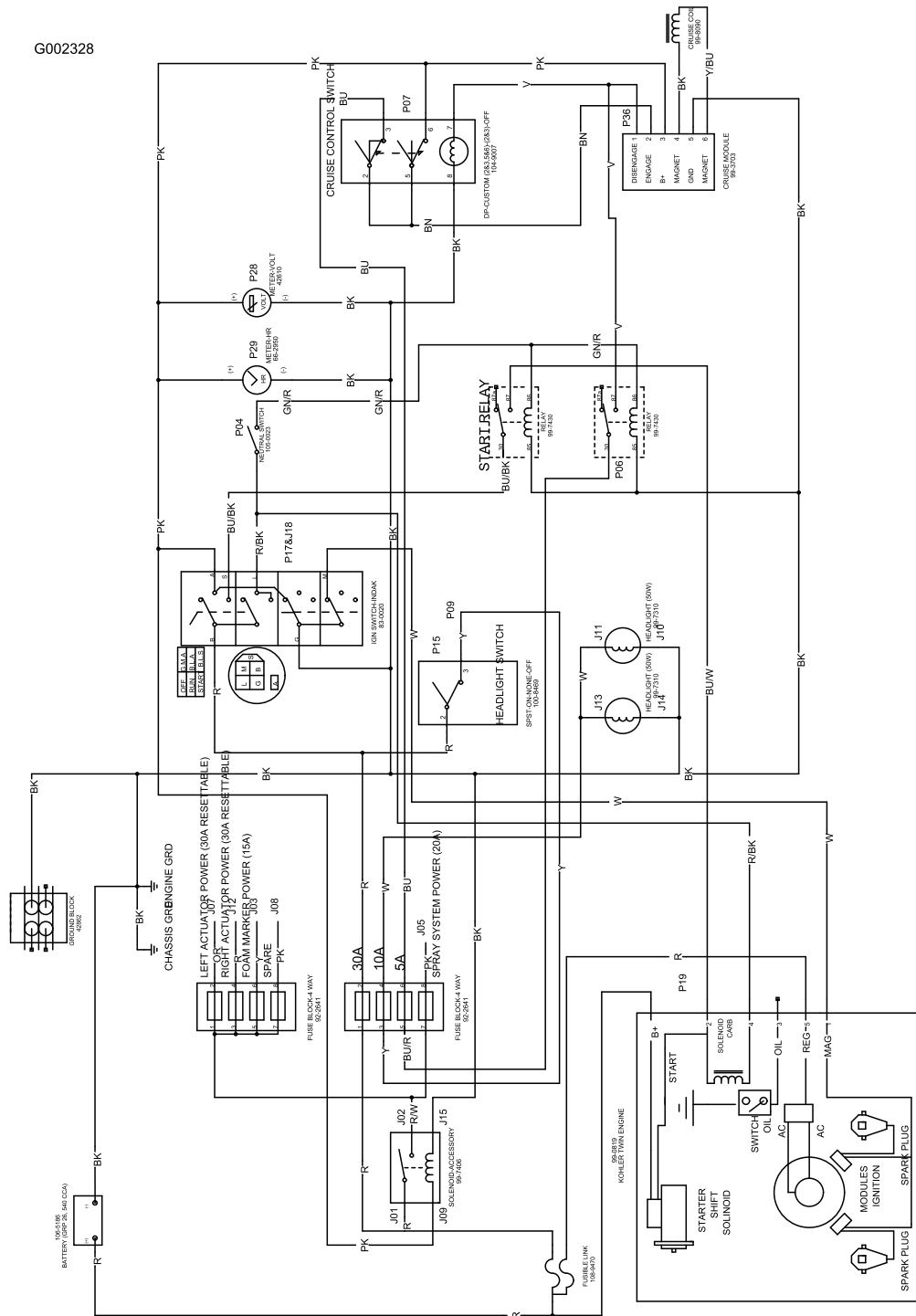

Electrical, vehicle (Rev. B)

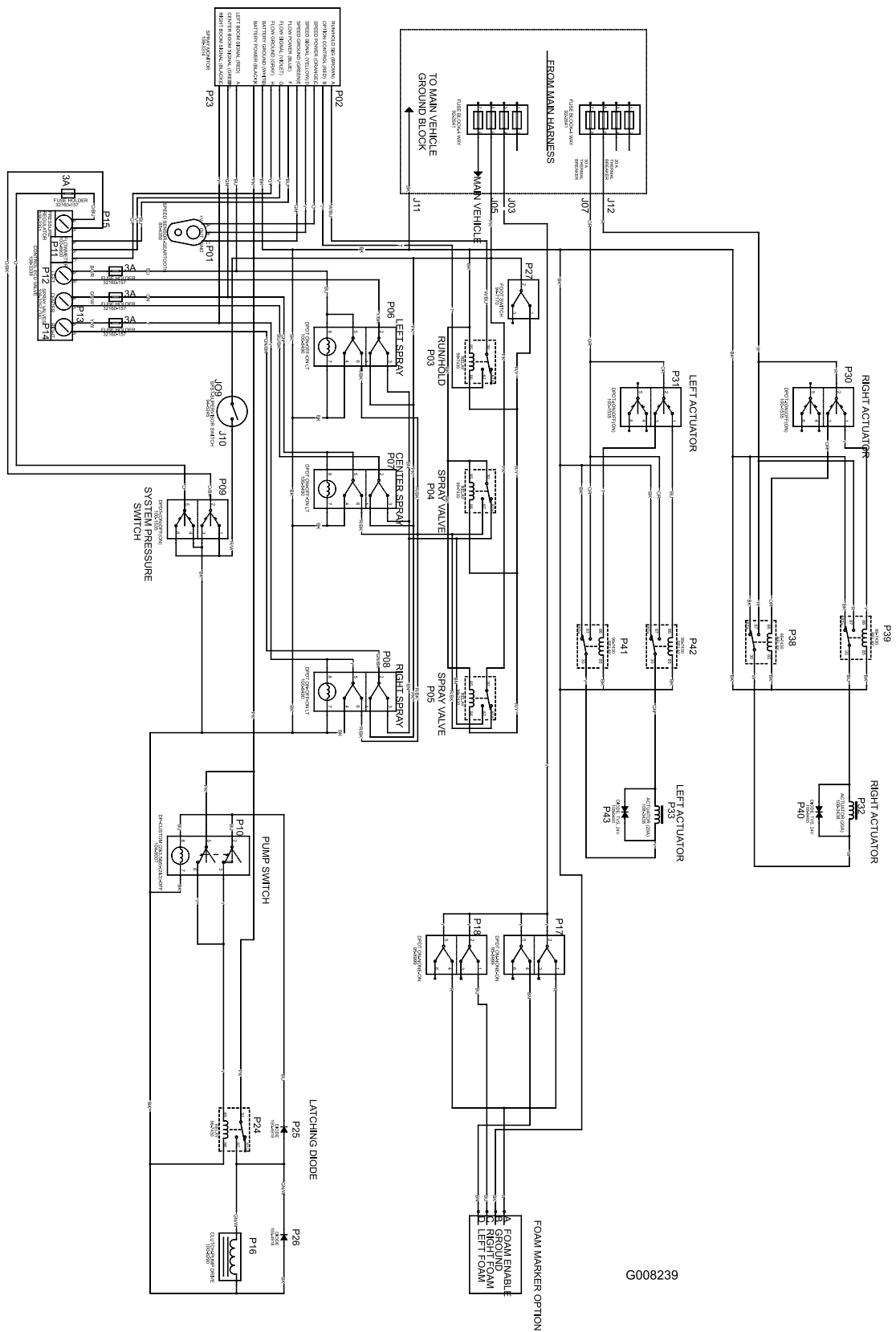

G008239

Electrical, spray system (Rev. A)

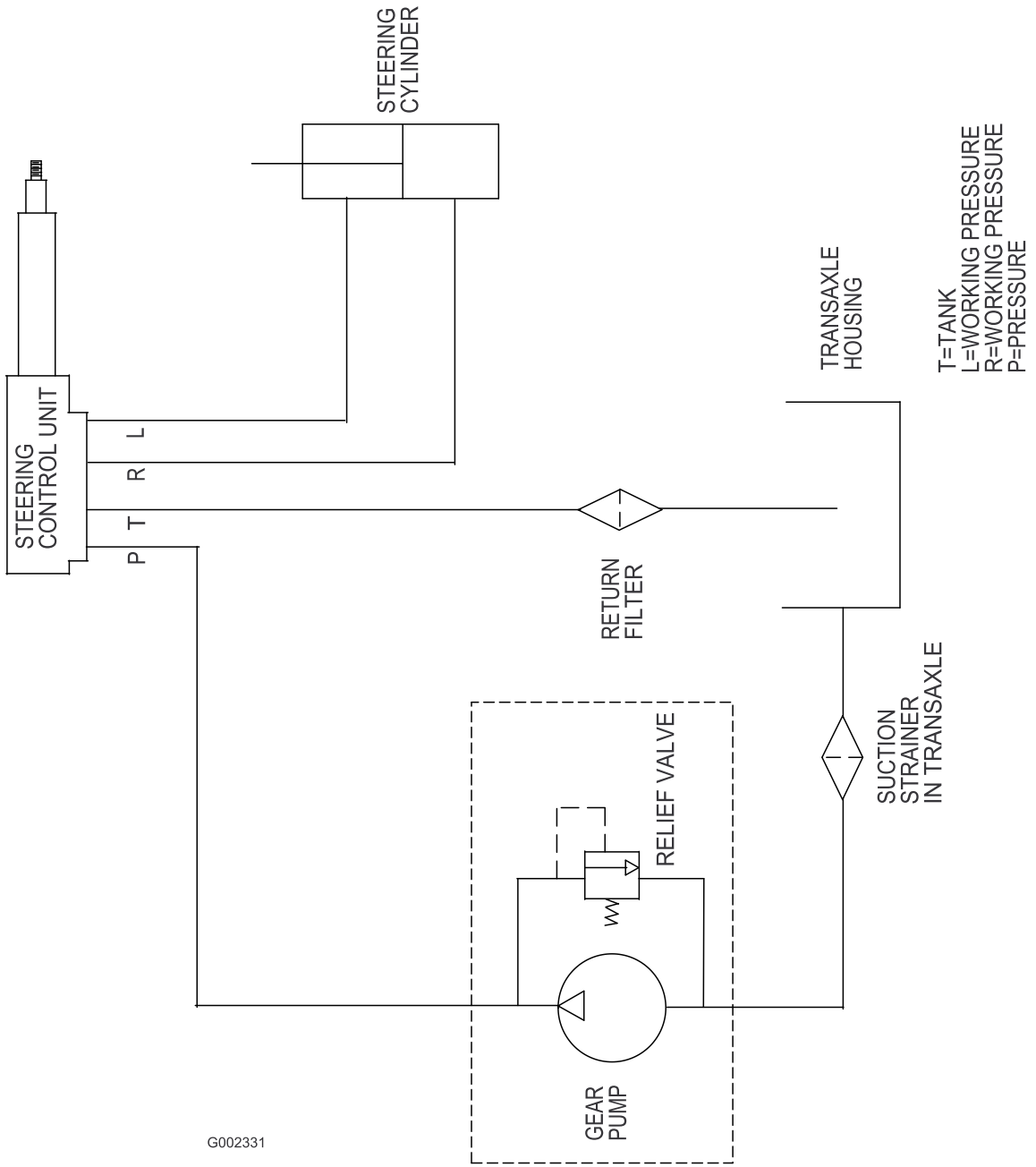

T=TANK
 L=WORKING PRESSURE
 R=WORKING PRESSURE
 P=PRESSURE

G002331

Hydraulic (Rev. A)

MP 1250 FLOW DIAGRAM

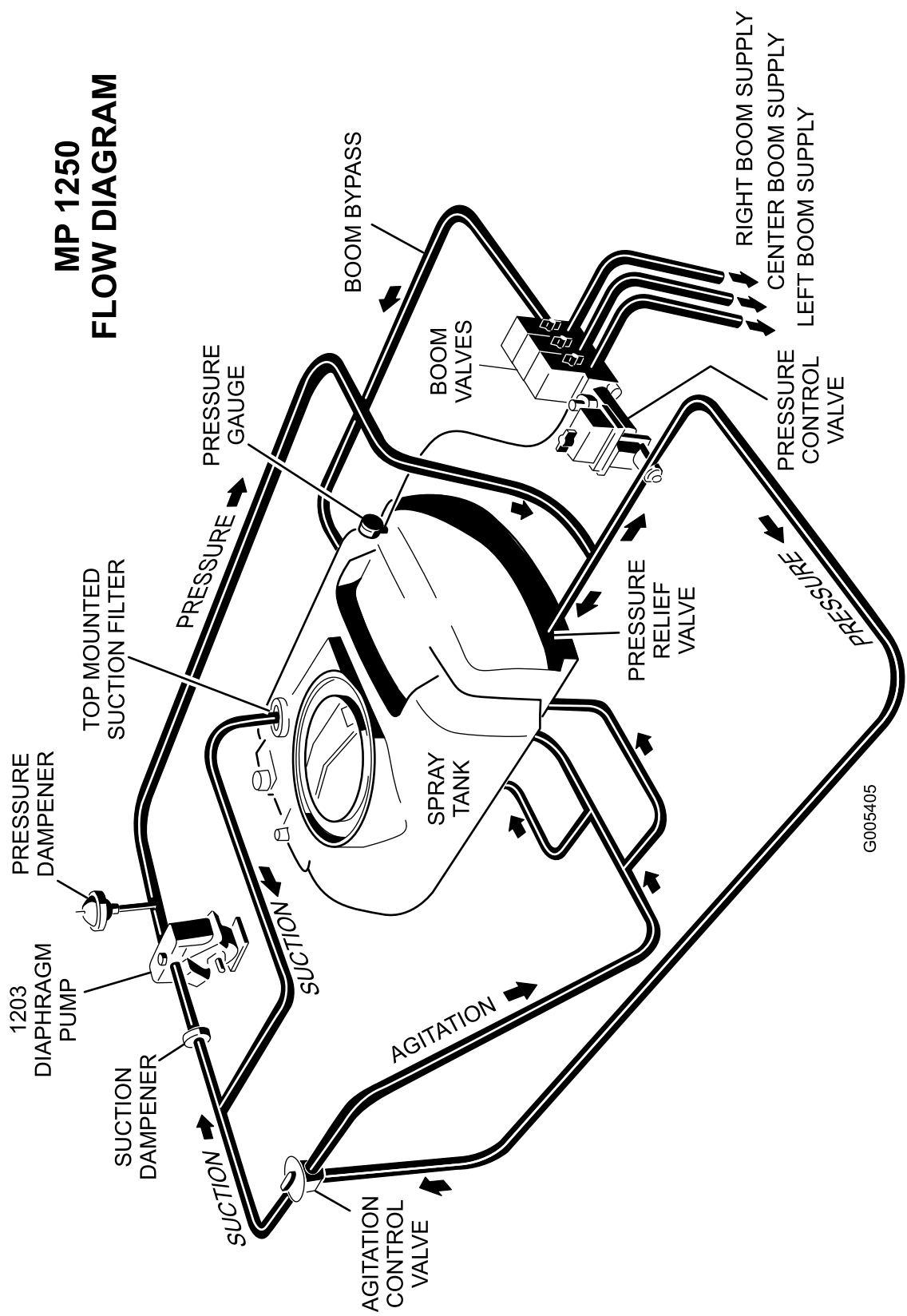

G005405

Flow Diagram (Rev. A)

Notes:

Notes:

The Toro Total Coverage Guarantee

A Limited Warranty

Conditions and Products Covered

The Toro® Company and its affiliate, Toro Warranty Company, pursuant to an agreement between them, jointly warrant your Toro Commercial product ("Product") to be free from defects in materials or workmanship for two years or 1500 operational hours*, whichever occurs first. This warranty is applicable to all products with the exception of Aerators (refer to separate warranty statements for these products). Where a warrantable condition exists, we will repair the Product at no cost to you including diagnostics, labor, parts, and transportation. This warranty begins on the date the Product is delivered to the original retail purchaser.

* Product equipped with an hour meter.

Instructions for Obtaining Warranty Service

You are responsible for notifying the Commercial Products Distributor or Authorized Commercial Products Dealer from whom you purchased the Product as soon as you believe a warrantable condition exists. If you need help locating a Commercial Products Distributor or Authorized Dealer, or if you have questions regarding your warranty rights or responsibilities, you may contact us at:

Commercial Products Service Department
Toro Warranty Company
8111 Lyndale Avenue South
Bloomington, MN 55420-1196
E-mail: commercial.warranty@toro.com

Owner Responsibilities

As the Product owner, you are responsible for required maintenance and adjustments stated in your Operator's Manual. Failure to perform required maintenance and adjustments can be grounds for disallowing a warranty claim.

Items and Conditions Not Covered

Not all product failures or malfunctions that occur during the warranty period are defects in materials or workmanship. This warranty does not cover the following:

- Product failures which result from the use of non-Toro replacement parts, or from installation and use of add-on, or modified non-Toro branded accessories and products. A separate warranty may be provided by the manufacturer of these items.
- Product failures which result from failure to perform recommended maintenance and/or adjustments. Failure to properly maintain your Toro product per the Recommended Maintenance listed in the *Operator's Manual* can result in claims for warranty being denied.
- Product failures which result from operating the Product in an abusive, negligent or reckless manner.
- Parts subject to consumption through use unless found to be defective. Examples of parts which are consumed, or used up, during normal Product operation include, but are not limited to, brakes pads and linings, clutch linings, blades, reels, bed knives, tines, spark plugs, castor wheels, tires, filters, belts, and certain sprayer components such as diaphragms, nozzles, and check valves, etc.
- Failures caused by outside influence. Items considered to be outside influence include, but are not limited to, weather, storage practices, contamination, use of unapproved coolants, lubricants, additives, fertilizers, water, or chemicals, etc.

Countries Other than the United States or Canada

Customers who have purchased Toro products exported from the United States or Canada should contact their Toro Distributor (Dealer) to obtain guarantee policies for your country, province, or state. If for any reason you are dissatisfied with your Distributor's service or have difficulty obtaining guarantee information, contact the Toro importer. If all other remedies fail, you may contact us at Toro Warranty Company.

- Normal noise, vibration, wear and tear, and deterioration.
- Normal "wear and tear" includes, but is not limited to, damage to seats due to wear or abrasion, worn painted surfaces, scratched decals or windows, etc.

Parts

Parts scheduled for replacement as required maintenance are warranted for the period of time up to the scheduled replacement time for that part. Parts replaced under this warranty are covered for the duration of the original product warranty and become the property of Toro. Toro will make the final decision whether to repair any existing part or assembly or replace it. Toro may use remanufactured parts for warranty repairs.

Note Regarding Deep Cycle Battery Warranty:

Deep cycle batteries have a specified total number of kilowatt-hours they can deliver during their lifetime. Operating, recharging, and maintenance techniques can extend or reduce total battery life. As the batteries in this product are consumed, the amount of useful work between charging intervals will slowly decrease until the battery is completely worn out. Replacement of worn out batteries, due to normal consumption, is the responsibility of the product owner. Battery replacement may be required during the normal product warranty period at owner's expense.

Maintenance is at Owner's Expense

Engine tune-up, lubrication cleaning and polishing, replacement of Items and Conditions Not Covered filters, coolant, and completing Recommended Maintenance are some of the normal services Toro products require that are at the owner's expense.

General Conditions

Repair by an Authorized Toro Distributor or Dealer is your sole remedy under this warranty.

Neither The Toro Company nor Toro Warranty Company is liable for indirect, incidental or consequential damages in connection with the use of the Toro Products covered by this warranty, including any cost or expense of providing substitute equipment or service during reasonable periods of malfunction or non-use pending completion of repairs under this warranty. Except for the Emissions warranty referenced below, if applicable, there is no other express warranty.

All implied warranties of merchantability and fitness for use are limited to the duration of this express warranty. Some states do not allow exclusions of incidental or consequential damages, or limitations on how long an implied warranty lasts, so the above exclusions and limitations may not apply to you.

This warranty gives you specific legal rights, and you may also have other rights which vary from state to state.

Note regarding engine warranty:

The Emissions Control System on your Product may be covered by a separate warranty meeting requirements established by the U.S. Environmental Protection Agency (EPA) and/or the California Air Resources Board (CARB). The hour limitations set forth above do not apply to the Emissions Control System Warranty. Refer to the Engine Emission Control Warranty Statement printed in your *Operator's Manual* or contained in the engine manufacturer's documentation for details