



**Count on it.**

**Operator's Manual**

**Greensmaster® Flex 18 or Flex 21  
Walk-Behind Mower**

**Model No. 04202 (Cutting Unit)—Serial No. 310000001  
and Up**

**Model No. 04206 (Cutting Unit)—Serial No. 310000001  
and Up**

**Model No. 04207 (Cutting Unit)—Serial No. 310000001  
and Up**

**Model No. 04208 (Cutting Unit)—Serial No. 310000001  
and Up**

**Model No. 04019 (Traction Unit)—Serial No. 310000001  
and Up**

**Model No. 04024 (Traction Unit)—Serial No. 310000001  
and Up**

**Model No. 04025 (Traction Unit)—Serial No. 310000001  
and Up**

This product complies with all relevant European directives, for details please see the separate product specific Declaration of Conformity (DOC) sheet.

## Warning

### CALIFORNIA Proposition 65 Warning

The engine exhaust from this product contains chemicals known to the State of California to cause cancer, birth defects, or other reproductive harm.

**Important:** This engine is not equipped with a spark arrester muffler. It is a violation of California Public Resource Code Section 4442 to use or operate the engine on any forest-covered, brush-covered, or grass-covered land. Other states or federal areas may have similar laws.

This spark ignition system complies with Canadian ICES-002.

## Introduction

This machine is a walk-behind, reel-blade lawn mower intended to be used by professional, hired operators in commercial applications. It is primarily designed for cutting grass on well-maintained lawns in parks, golf courses, sports fields, and on commercial grounds. It is not designed for cutting brush, mowing grass and other growth alongside highways, or for agricultural uses.

Read this information carefully to learn how to operate and maintain your product properly and to avoid injury and product damage. You are responsible for operating the product properly and safely.

You may contact Toro directly at [www.Toro.com](http://www.Toro.com) for product and accessory information, help finding a dealer, or to register your product.

Whenever you need service, genuine Toro parts, or additional information, contact an Authorized Service Dealer or Toro Customer Service and have the model and serial numbers of your product ready. Figure 1 and Figure 2 identify the location of the model and serial numbers on the product. Write the numbers in the space provided.

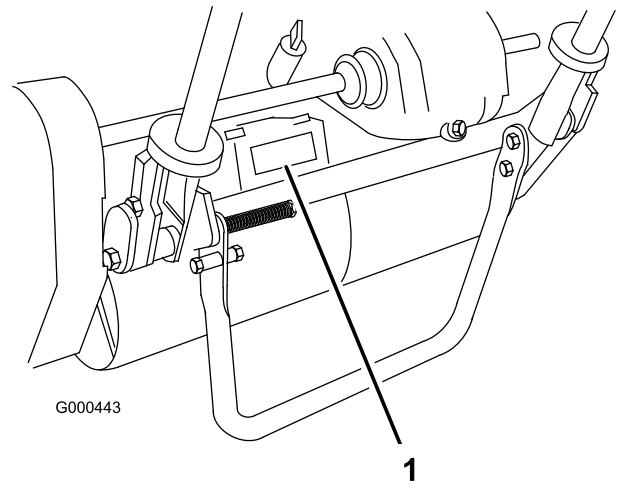

Figure 1

1. Location of the model and serial numbers-Traction unit

Traction unit:

Model No. \_\_\_\_\_

Serial No. \_\_\_\_\_

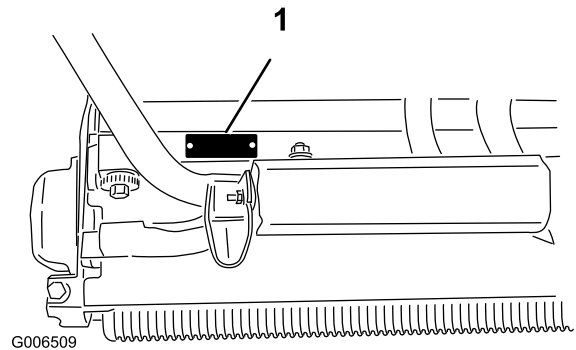

Figure 2

1. Location of the model and serial numbers-Cutting Unit

Cutting unit:

Model No. \_\_\_\_\_

Serial No. \_\_\_\_\_

This manual identifies potential hazards and has safety messages identified by the safety alert symbol (Figure 3), which signals a hazard that may cause serious injury or death if you do not follow the recommended precautions.



Figure 3

1. Safety alert symbol.

This manual uses two other words to highlight information. **Important** calls attention to special mechanical information and **Note** emphasizes general information worthy of special attention.

# Contents

Introduction.....	2
Safety.....	4
Safe Operating Practices.....	4
Toro Mower Safety.....	5
Sound Power Level-Flex 18.....	6
Sound Pressure Level-Flex 18.....	6
Vibration Level-Flex 18.....	6
Sound Power Level-Flex 21.....	6
Sound Pressure Level-Flex 21.....	7
Vibration Level-Flex 21.....	7
Safety and Instructional Decals.....	7
Setup.....	9
1 Installing the Cutting Unit to the Traction Unit.....	10
2 Installing the Handle.....	10
3 Installing the Kickstand for Flex 18 Mowers Only.....	11
4 Adjusting the Handle.....	12
5 Installing the Transport Wheels.....	12
6 Checking Fluid Levels.....	13
7 Installing the Grass Basket.....	13
Product Overview.....	14
Controls.....	14
Specifications.....	15
Attachments/Accessories.....	15
Operation.....	16
Think Safety First.....	16
Checking the Engine Oil Level.....	16
Filling the Fuel Tank.....	16
Checking the Interlock Switch Operation.....	17
Starting and Stopping the Engine.....	17
Transport Operation.....	18
Preparing to Mow.....	18
Mowing Operation.....	18
Maintenance.....	20
Recommended Maintenance Schedule(s).....	20
Daily Maintenance Checklist.....	21
Engine Maintenance.....	22
Engine Oil.....	22

Servicing the Air Cleaner.....	23
Replacing the Spark Plug.....	23
Fuel System Maintenance.....	24
Cleaning the Fuel Filter.....	24
Electrical System Maintenance.....	25
Servicing the Interlock Switch.....	25
Drive System Maintenance.....	25
Checking the Transmission Fluid Level.....	25
Changing the Transmission Fluid.....	26
Brake Maintenance.....	26
Adjusting the Service/Parking Brake.....	26
Belt Maintenance.....	27
Adjusting the Belts.....	27
Controls System Maintenance.....	30
Adjusting the Traction Control.....	30
Adjusting the Reel Control.....	30
Cutting Unit Maintenance.....	31
Separating the Cutting Unit from the Traction Unit.....	31
Adjusting the Rear Roller.....	31
Adjusting the Bedknife to the Reel.....	32
Adjusting the Height of Cut.....	33
Adjusting the Cut-Off Bar.....	34
Setting the Machine to Match Turf Conditions.....	35
Servicing the Bedbar.....	36
Backlapping the Reel.....	37
Storage.....	38

# Safety

This machine meets or exceeds CEN standard EN 836:1997, ISO standard 5395:1990, and ANSI B71.4-2004 specifications in effect at the time of production when the Operator Presence Kit, Part No. 105-5333 is installed.

Improper use or maintenance by the operator or owner can result in injury. To reduce the potential for injury, comply with these safety instructions and always pay attention to the safety alert **▲** symbol, which means CAUTION, WARNING, or DANGER-“personal safety instruction.” Failure to comply with the instruction may result in personal injury or death.

## Safe Operating Practices

The following instructions are from the CEN standard EN 836:1997, ISO standard 5395:1990, and ANSI B71.4-2004.

### Training

- Read the Operator’s Manual and other training material carefully. Be familiar with the controls, safety signs, and the proper use of the equipment.
- Never allow children or people unfamiliar with these instructions to use or service the mower. Local regulations may restrict the age of the operator.
- Never mow while people, especially children, or pets are nearby.
- Keep in mind that the operator or user is responsible for accidents or hazards occurring to other people or their property.
- The owner/user can prevent and is responsible for accidents or injuries occurring to himself or herself, other people, or property.

### Preparation

- While mowing, always wear substantial footwear, long trousers, hard hat, safety glasses, and ear protection. Long hair, loose clothing, or jewelry may get tangled in moving parts. Do not operate the equipment when barefoot or wearing open sandals.
- Thoroughly inspect the area where the equipment is to be used and remove all objects which may be thrown by the machine.
- Warning-Fuel is highly flammable. Take the following precautions:
  - Store fuel in containers specifically designed for this purpose.

- Refuel outdoors only and do not smoke while refuelling.
- Add fuel before starting the engine. Never remove the cap of the fuel tank or add fuel while the engine is running or when the engine is hot.
- If fuel is spilled, do not attempt to start the engine but move the machine away from the area of spillage and avoid creating any source of ignition until fuel vapors have dissipated.
- Replace all fuel tanks and container caps securely.
- Replace faulty silencers.
- Evaluate the terrain to determine what accessories and attachments are needed to properly and safely perform the job. Only use accessories and attachments approved by the manufacturer.
- Check that operator’s presence controls, safety switches and shields are attached and functioning properly. Do not operate unless they are functioning properly.

### Operation

- Do not operate the engine in a confined space where dangerous carbon monoxide fumes can collect.
- Mow only in daylight or in good artificial light.
- Before attempting to start the engine, disengage all blade attachment clutches, shift into neutral, and engage the parking brake.
- Stay alert for holes in the terrain and other hidden hazards.
- Watch out for traffic when crossing or near roadways.
- Stop the blades rotating before crossing surfaces other than grass.
- When using any attachments, never direct discharge of material toward bystanders nor allow anyone near the machine while in operation.
- Never operate the machine with damaged guards, shields, or without safety protective devices in place. Be sure all interlocks are attached, adjusted properly, and functioning properly.
- Do not change the engine governor settings or overspeed the engine. Operating the engine at excessive speed may increase the hazard of personal injury.
- Before leaving the operator’s position:
  - stop on level ground;
  - disengage the power take-off and lower the attachments;

- change into neutral and set the parking brake;
- stop the engine.
- Disengage drive to attachments when transporting or not in use.
- Stop the engine and disengage drive to attachment
  - before refuelling;
  - before removing the grass catcher/catchers;
  - before making height adjustment unless adjustment can be made from the operator’s position.
  - before clearing blockages;
  - before checking, cleaning or working on the mower;
  - after striking a foreign object or if an abnormal vibration occurs. Inspect the mower for damage and make repairs before restarting and operating the equipment.
- Reduce the throttle setting before stopping engine and, if the engine is provided with a fuel shut-off valve, turn the valve off at the conclusion of mowing.
- Keep hands and feet away from the cutting unit.
- Slow down and use caution when making turns and crossing roads and sidewalks. Stop reels if not mowing.
- Do not operate the mower under the influence of alcohol or drugs
- Lightning can cause severe injury or death. If lightning is seen or thunder is heard in the area, do not operate the machine; seek shelter.
- Use care when loading or unloading the machine into a trailer or truck
- Use care when approaching blind corners, shrubs, trees, or other objects that may obscure vision.
- Keep all parts in good working condition and all hardware and hydraulic fittings tightened. Replace all worn or damaged parts and decals.
- If the fuel tank has to be drained, do this outdoors.
- Be careful during adjustment of the machine to prevent entrapment of the fingers between moving blades and fixed parts of the machine.
- Disengage drives, disengage the cutting unit, set parking brake, stop engine and disconnect spark plug wire. Wait for all movement to stop before adjusting, cleaning or repairing.
- Clean grass and debris from cutting unit, drives, mufflers, and engine to help prevent fires. Clean up oil or fuel spillage.
- Carefully release pressure from components with stored energy.
- Disconnect battery and remove spark plug wire before making any repairs. Disconnect the negative terminal first and the positive last. Reconnect positive first and negative last.
- Use care when checking the reel. Wear gloves and use caution when servicing them.
- Keep hands and feet away from moving parts. If possible, do not make adjustments with the engine running.

## Maintenance and Storage

- Keep all nuts, bolts and screws tight to be sure the equipment is in safe working condition.
- Never store the equipment with fuel in the tank inside a building where fumes may reach an open flame or spark.
- Allow the engine to cool before storing in any enclosure.
- To reduce the fire hazard, keep the engine, silencer, battery compartment and fuel storage area free of grass, leaves, or excessive grease.
- Check the grass catcher frequently for wear or deterioration.

## Toro Mower Safety

The following list contains safety information specific to Toro products or other safety information that you must know that is not included in the CEN, ISO, or ANSI standard.

This product is capable of amputating hands and feet and throwing objects. Always follow all safety instructions to avoid serious injury or death.

Use of this product for purposes other than its intended use could prove dangerous to user and bystanders.

- Know how to stop the engine quickly.
- Do not operate the machine while wearing tennis shoes or sneakers.
- Wearing safety shoes and long pants is advisable and required by some local ordinances and insurance regulations.
- Handle gasoline carefully. Wipe up any spills.
- Check the safety interlock switches daily for proper operation. If a switch should fail, replace the switch before operating the machine.
- Always stand behind the handle when starting and operating the machine.

- To start and stop the engine:
  - Open fuel shut-off valve.
  - Verify that the traction and reel drive control levers on handle are in Neutral position.
  - Move the on/off switch, located on the control panel, to ON position, set choke to full choke position (cold start) and throttle to half throttle.
  - Pull starter cord to start engine.
  - Move throttle to Slow and on/off switch to Off position to stop engine.
- To transport mower from one area to another:
  - Install transport wheels.
  - Disengage reel drive.
  - Start engine.
  - Press down on handle to raise front of mower and engage traction drive.
- Before beginning mowing operation:
  - Disengage traction drive.
  - Stop engine.
  - Remove transport wheels.
  - Start engine
  - Engage reel drive.
- Using the machine demands attention. To prevent loss of control:
  - Do not drive close to sand traps, ditches, creeks, or other hazards.
  - Reduce speed when making sharp turns. Avoid sudden stops and starts.
  - When near or crossing roads, always yield the right-of-way.
- The grass basket must be in place, during the mowing operation, for maximum safety. Shut the engine off before emptying the basket.
- Do not touch the engine, muffler, or exhaust pipe while the engine is running or soon after it has stopped because these areas could be hot enough to cause burns.
- When a person or pet appears unexpectedly in or near the mowing area, stop mowing. Careless operation, combined with terrain angles, ricochets, or improperly positioned guards can lead to thrown object injuries. Do not resume mowing until the area is cleared.
- If the engine must be running to perform a maintenance adjustment, keep hands, feet, clothing, and any parts of the body away from the cutting unit, attachments and any moving parts. Keep everyone away.
- To ensure safety and accuracy, have an Authorized Toro Distributor check the maximum engine speed with a tachometer. Maximum governed engine speed should be 3600 RPM.
- If major repairs are ever needed or if assistance is desired, contact an Authorized Toro Distributor.
- Use only Toro-approved attachments and replacement parts. The warranty may be voided if used with unapproved attachments.

## Sound Power Level-Flex 18

This unit has a guaranteed sound power level of 96 dBA, which includes an Uncertainty Value (K) of 1 dBA.

Sound power level was determined according to the procedures outlined in EN 11094.

## Sound Pressure Level-Flex 18

This unit has a sound pressure level at the operator's ear of 84 dBA, which includes an Uncertainty Value (K) of 1 dBA.

Sound pressure level was determined according to the procedures outlined in EN 836.

## Vibration Level-Flex 18

### Hand-Arm

Measured vibration level for right hand = 2.36 m/s<sup>2</sup>

Measured vibration level for left hand = 2.47 m/s<sup>2</sup>

Uncertainty Value (K) = 0.5 m/s<sup>2</sup>

Measured values were determined according to the procedures outlined in EN 836.

## Sound Power Level-Flex 21

This unit has a guaranteed sound power level of 97 dBA, which includes an Uncertainty Value (K) of 1 dBA.

Sound power level was determined according to the procedures outlined in EN 11094.

## Maintenance and Storage

- Check all fuel lines for tightness and wear on a regular basis. Tighten or repair them as needed.

## Sound Pressure Level-Flex 21

This unit has a sound pressure level at the operator's ear of 92 dBA, which includes an Uncertainty Value (K) of 1 dBA.

Sound pressure level was determined according to the procedures outlined in EN 836.

## Vibration Level-Flex 21

### Hand-Arm

Measured vibration level for right hand = 2.36 m/s<sup>2</sup>

Measured vibration level for left hand = 2.47 m/s<sup>2</sup>

Uncertainty Value (K) = 0.5 m/s<sup>2</sup>

Measured values were determined according to the procedures outlined in EN 836.

## Safety and Instructional Decals



Safety decals and instructions are easily visible to the operator and are located near any area of potential danger. Replace any decal that is damaged or lost.

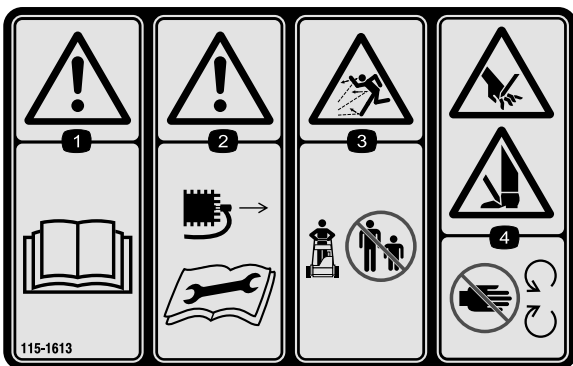

115-1613

1. Warning—read the *Operator's Manual*.
2. Warning—remove the spark plug wire before performing any maintenance on the machine.
3. Thrown object hazard—keep bystanders a safe distance from the machine.
4. Cutting, dismemberment hazard of hand or foot—stay away from moving parts.



115-1615

1. Warning—do not touch the hot surface.

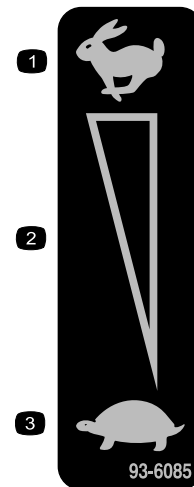

93-6085

1. Fast
2. Continuous variable setting
3. Slow

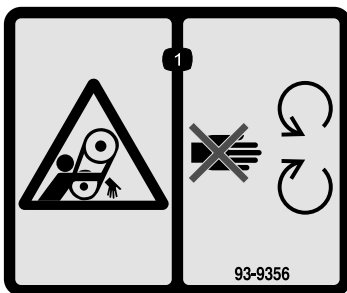

93-9356

1. Entanglement hazard—stay away from moving parts.



112-9408

1. Engine—stop
2. Engine—run

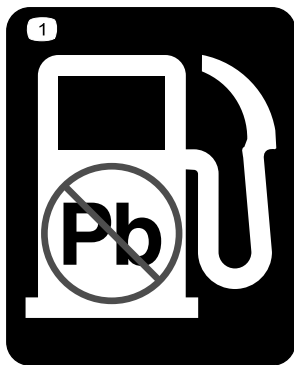

93-9886

1. Use unleaded gasoline.

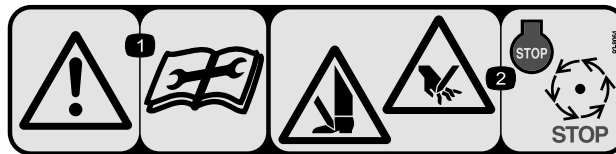

93-8064

1. Warning—read the instructions before servicing or performing maintenance.
2. Cutting hazard of hand or foot—stop the engine and wait for moving parts to stop.

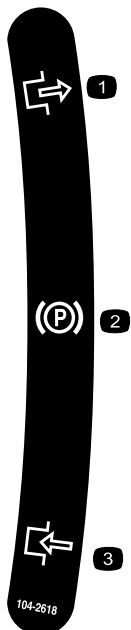

104-2618

1. Parking brake
2. Disengage
3. Engage

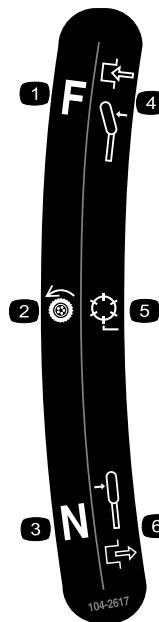

104-2617

1. Traction drive
2. Reel drive
3. Neutral
4. Forward
5. Lever engaged
6. Lever disengaged



105-2411

1. Transmission oil



115-1614

1. Warning—read the *Operator's Manual*.
2. Warning—do not operate the machine unless you are trained.
3. Thrown object hazard—keep bystanders a safe distance from the machine.
4. Warning—stay away from moving parts; keep all guards in place.



# Setup

## Loose Parts

Use the chart below to verify that all parts have been shipped.

Procedure	Description	Qty.	Use
<b>1</b>	Bolt, M10 x 25mm	2	
<b>2</b>	Handle	1	Install the handle.
<b>3</b>	Kickstand assembly Spring Small spacer Large spacer Large bolt (M8–1.25 x 100) Small bolt (M8–1.25 x 030) Locknut (M8 x 1.25) Washer (M8)	1 1 1 1 1 1 2 2	Install the kickstand for Flex 18 Mowers Only.
<b>4</b>	No parts required	–	Adjust the handle.
<b>5</b>	Transport wheels (Optional Transport Wheel Kit, Model 04123)	2	Install the transport wheels.
<b>6</b>	No parts required	–	Check the engine oil and transmission fluid levels
<b>7</b>	Grass basket	1	Install the grass basket.

## Media and Additional Parts

Description	Qty.	Use
Operator's Manual	1	Read or view before operating the machine
Engine Operator's Manual	1	
Parts Catalog	1	
Operator Training Material	1	
Certificate of Compliance	1	

**Note:** Determine the left and right sides of the machine from the normal operating position.

# 1

## Installing the Cutting Unit to the Traction Unit

### Parts needed for this procedure:

2	Bolt, M10 x 25mm
---	------------------

1. Place the mower on its drums on a level surface.
2. Lower kick stand. Insert a 1/4" dia. pin or equivalent into frame hole above kick stand mounting bolt (Figure 4).

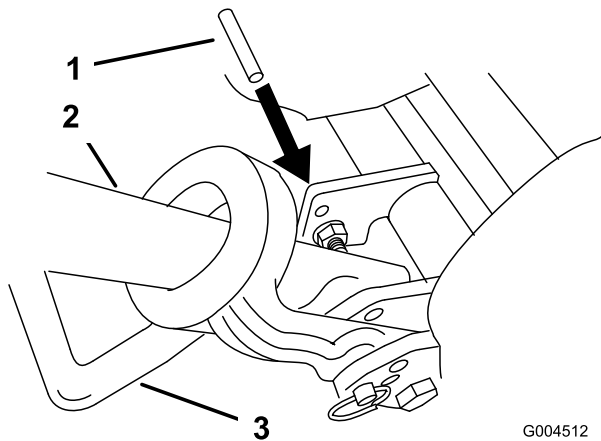

Figure 4

1. 1/4" Pin
2. Handle
3. Kick stand

3. Push the cutting unit under the traction unit and then to the left to engage the transmission coupling (Figure 5).

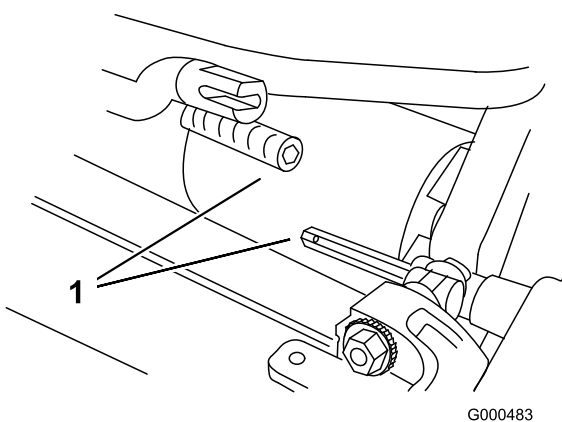

Figure 5

1. Transmission coupling

4. Rotate the traction unit frame (Figure 6) forward until it engages the cutting unit pivot arms.
5. Secure the traction unit frame to the cutting unit pivot arms with (2) M10 x 25mm bolts (Figure 6)

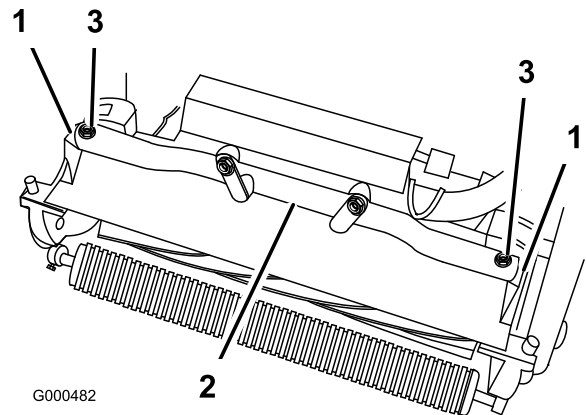

Figure 6

1. Cutting unit pivot arms
2. Traction unit frame
3. Bolts

**Note:** When tightening the pivot arm mounting fasteners, use an adjustable end wrench to hold the pivot arm parallel to the side plate (Figure 7)

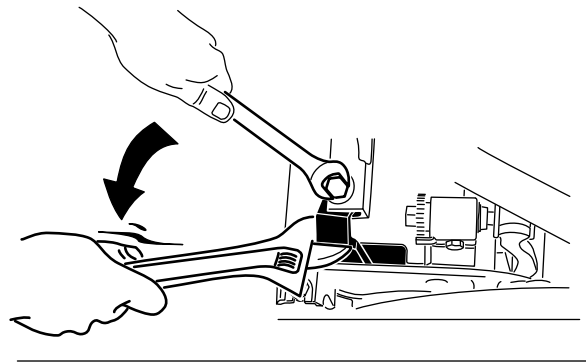

Figure 7

# 2

## Installing the Handle

### Parts needed for this procedure:

1	Handle
---	--------

### Procedure

1. Remove the flange lock nut from the bolt and pivot pin on each side of the mower (Figure 8).

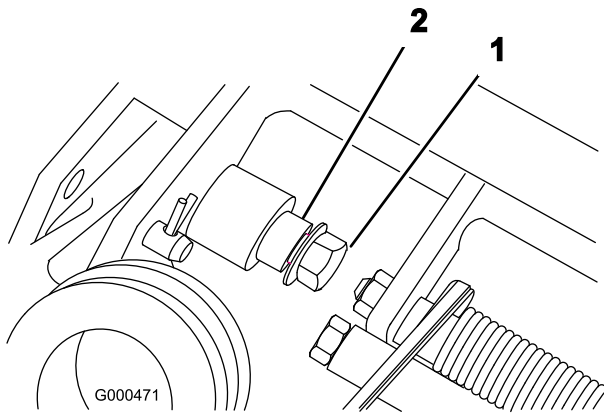

Figure 8

1. Flange lock nut
2. Pivot pin

2. Insert the handle ends through the slots in the handle support arms (Figure 9).

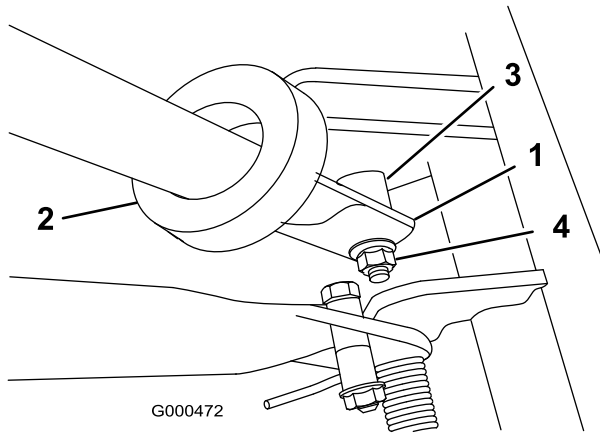

Figure 9

1. Left handle end
2. Support arm
3. Pivot pin
4. Locknut

3. Squeeze the handle ends inward and install them on the step of the pivot pin (Figure 9).

4. Secure the handle to the bolt and pivot pin with the flange lock nut (Figure 9).
5. Locate cable tie loosely securing throttle cable to wire harness. Position cable tie approximately one inch behind transmission and tighten cable tie.

# 3

## Installing the Kickstand for Flex 18 Mowers Only

### Parts needed for this procedure:

1	Kickstand assembly
1	Spring
1	Small spacer
1	Large spacer
1	Large bolt (M8-1.25 x 100)
1	Small bolt (M8-1.25 x 030)
2	Locknut (M8 x 1.25)
2	Washer (M8)

### Procedure

1. Position the kickstand between the tabs on the rear of the frame.
2. Install a washer (M8) onto the small bolt (M8-1.25 x 030). Install the right side of the kickstand to the frame with the bolt and washer, the small spacer, and locknut (M8-1.25) (Figure 10). Ensure the bolt is installed from the inside of the frame as shown in Figure 10.
3. Install a washer (M8) onto the large bolt (M8-1.25 x 100).
4. Install the spacer into the spring and install the large bolt (M8-1.25 x 100) into the spacer.

**Important:** When installing the spring, place one end of the spring under the rear frame (Figure 10).

5. Install the left side of the kickstand to the frame with the bolt and washer, the large spacer and spring, and locknut (M8-1.25) (Figure 10). Ensure the bolt is installed from the inside of the frame as shown in Figure 10.

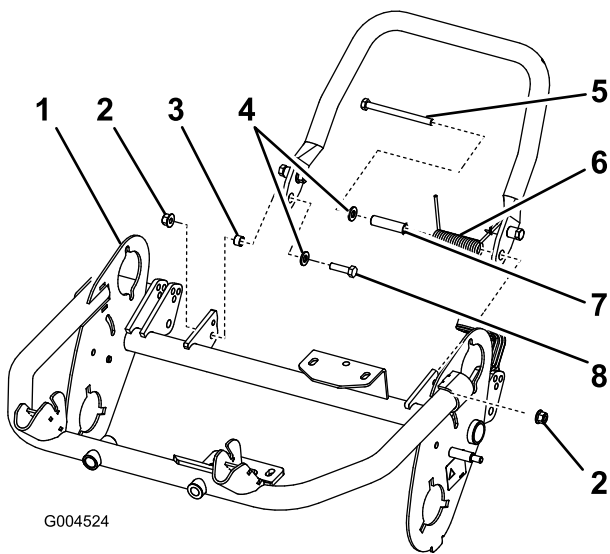

**Figure 10**

1. Left handle end
2. Locknut (M8-1.25)
3. Small spacer
4. Washer (M8)
5. Large bolt (M8-1.25 x 100)
6. Spring
7. Large spacer
8. Small bolt (M8-1.25 x 030)

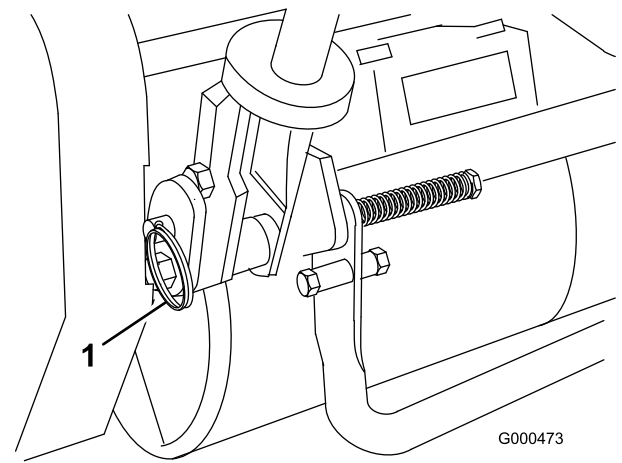

**Figure 12**

1. Ring pins
2. While supporting handle, remove ring pins from each side and raise or lower handle to desired operating position (Figure 12).
3. Reinstall ring pins and hair pin cotters.

6. Place a nut runner over the end of the spring pointing towards the rear and move the end of the spring over and under the kickstand spacer (Figure 11).

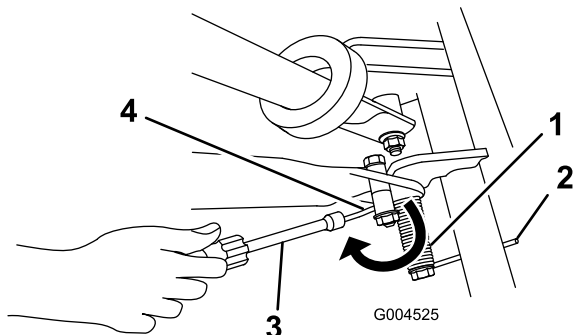

**Figure 11**

1. Spring
2. Spring end under the frame
3. Nut runner
4. Move the spring end under the kickstand spacer.

# 4

## Adjusting the Handle

### No Parts Required

### Procedure

1. Remove hairpin cotters from ring pins on each side of mower (Figure 12).

# 5

## Installing the Transport Wheels

### Parts needed for this procedure:

2	Transport wheels (Optional Transport Wheel Kit, Model 04123)
---	--

### Procedure

1. Push kick stand down with foot and pull up on handle support until kick stand has rotated forward, over center (Figure 13).

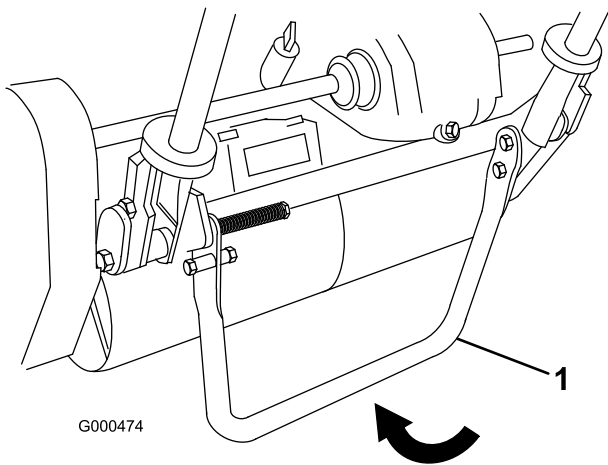

**Figure 13**

1. Kick stand

2. Press wheel locking clip toward the center of wheel and slide wheel onto hex shaft (Figure 14).

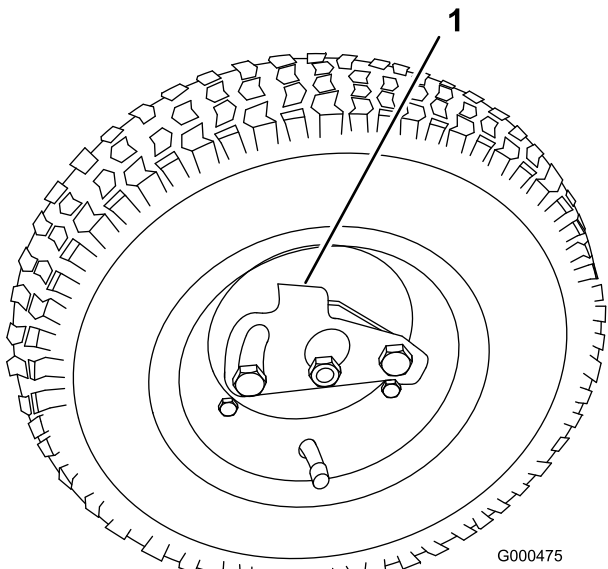

**Figure 14**

1. Locking clip

3. Rotate wheel back and forth until it slides completely onto axle and locking clip is secured in groove on axle shaft.
4. Repeat procedure on opposite side of machine.
5. Inflate the tires to 12-15 psi.
6. Carefully lift up on handle support to release kick stand.

## 6

### Checking Fluid Levels

#### No Parts Required

#### Procedure

1. Check the engine oil level, refer to Checking the Engine Oil Level.
2. Check the transmission fluid level, refer to Checking the Transmission Fluid Level.

## 7

### Installing the Grass Basket

#### Parts needed for this procedure:

1	Grass basket
---	--------------

#### Procedure

Grasp basket by top lip and slide basket frame into the receivers (Figure 15).

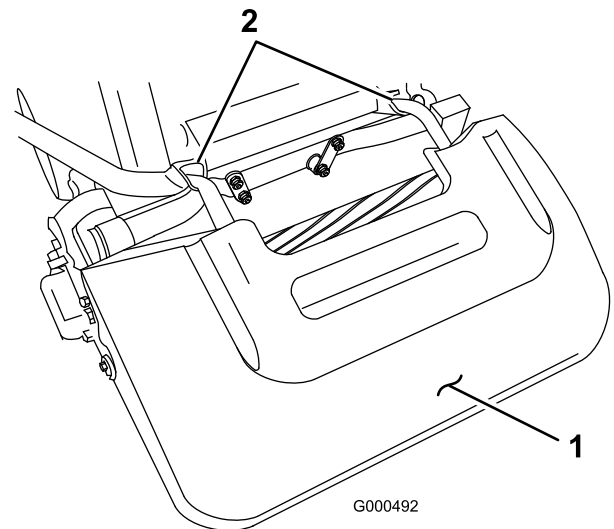

**Figure 15**

1. Grass basket
2. Basket receivers

# Product Overview

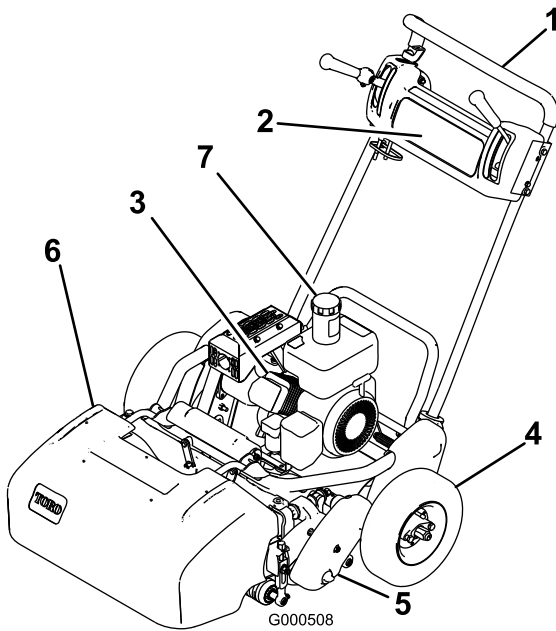

**Figure 16**

- |                     |                 |
|---------------------|-----------------|
| 1. Handle           | 5. Cutting unit |
| 2. Control panel    | 6. Grass basket |
| 3. Engine           | 7. Fuel tank    |
| 4. Transport wheels |                 |

## Controls

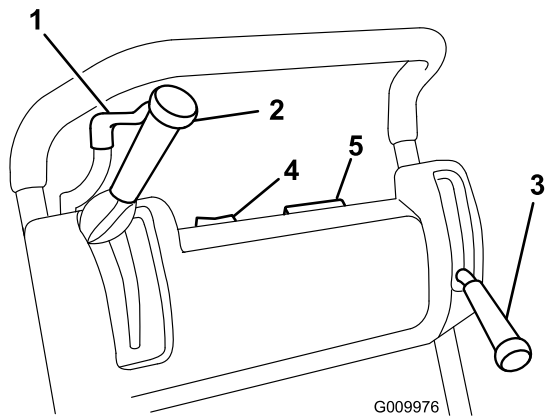

**Figure 17**

- |   |                  |
|---|------------------|
| 1. Throttle control                       | 4. On/off switch |
| 2. Traction & reel drive engagement lever | 5. Hour meter    |
| 3. Service/parking brake                  |                  |

## Throttle Control

The throttle control (Figure 17) is located on rear right side of control panel. Lever connects to and operates throttle linkage to carburetor. Engine speed can be varied from 2400 RPM to 3600 RPM.

## Traction and Reel Drive Engagement Lever

The traction and reel drive engagement lever (Figure 17) is located on front right side of control panel. Traction lever has two positions: Neutral and Forward. Pushing lever forward engages traction drive.

The reel drive lever has two positions: Engage and Disengage. Move top of lever to the left to engage reel or back to neutral to disengage reel.

## Service/Parking Brake

The service/parking brake (Figure 17) is located on left front side of control panel. Pulling the lever back over center will set the parking brake. Brake must be released before traction drive is engaged.

## On/Off Switch

The on/off switch (Figure 17) is located on top of control panel. Move switch to On position to start engine and Off to stop engine.

## Hour Meter

The hour meter (Figure 17), located on top of the control panel, indicates the total hours of machine operation.

## Operator Presence Control

The optional operator presence control must be engaged before engaging the traction lever or the engine will stop.

## Choke Lever

The choke lever (Figure 18) is located on left front of engine. Lever has two positions: Run and Choke. Move the choke lever to the half-open position when starting a cold engine. After engine starts move lever to Run position.

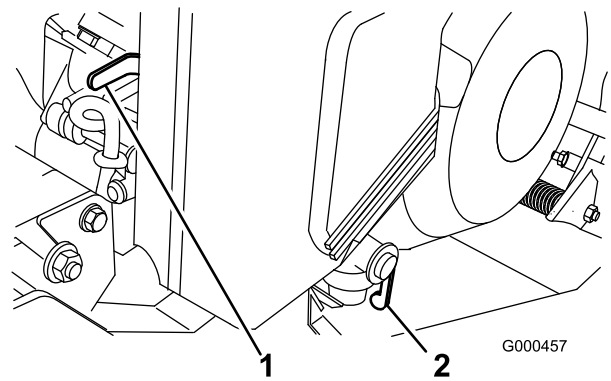

**Figure 18**

- |                |                        |
|----------------|------------------------|
| 1. Choke lever | 2. Fuel shut-off valve |
|----------------|------------------------|

## Fuel Shut-Off Valve

The fuel shut-off valve (Figure 18) is located on left front of engine. Valve has two positions: Closed and Open. Move lever to closed position when storing or transporting machine. Open valve before starting engine.

## Recoil Starter

Pull recoil starter handle (Figure 19) to start engine.

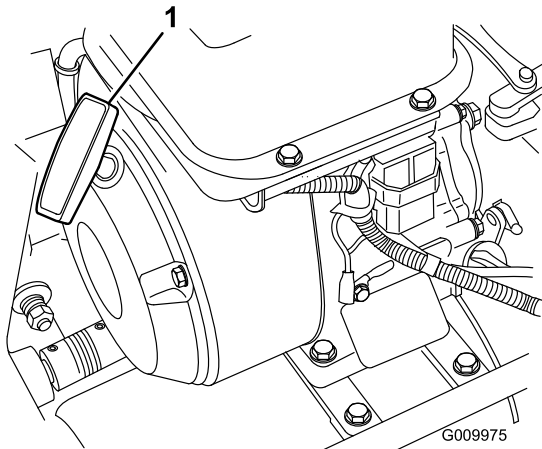

Figure 19

1. Recoil starter

## Kickstand

The kickstand (Figure 20) is mounted to rear of machine and is used to raise rear of machine for installation or removal of transport wheels.

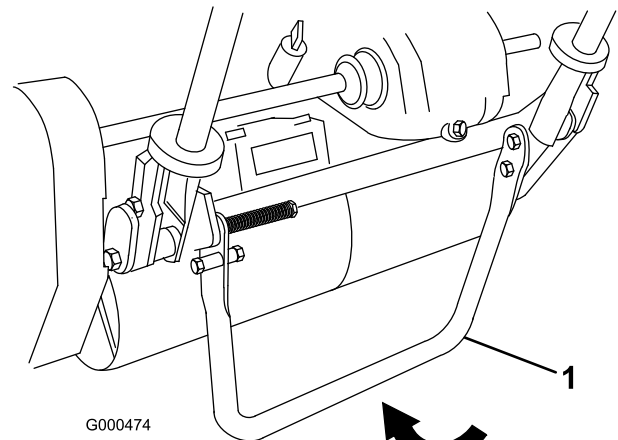

Figure 20

1. Kick stand

## Specifications

	Flex 21	Flex 18
Width	35-1/2 inches (90.1 cm)	32 inches (81.3 cm)
Height	41-1/4 inches (104.8 cm)	41-1/2 inches (105.4 cm)
Length with basket	61-1/2 inches (156.2 cm)	61 inches (155 cm)
Net weight	Model 04024-185 lb (84 kg) Model 04202-82 lb (37 kg) Model 04025-185 lb (84 kg) Model 04208-89 lb (40 kg)	Model 04019-175 lb (79 kg) Model 04206-82 lb (37 kg) Model 04207-89 lb (40 kg)
Width of cut	21 inches (53.3 cm)	18 inches (45.7 cm)
Height of cut	1/16 to 19/64 inches (1.5 to 7.5 mm) with Micro-Cut bedknife	1/16 to 19/64 inches (1.5 to 7.5 mm) with Micro-Cut bedknife
Clip frequency	11 blade (standard): .14 inch	11 blade (standard): .14 inch

## Attachments/Accessories

A selection of Toro approved attachments and accessories are available for use with the machine to enhance and expand its capabilities. Contact your Authorized Service Dealer or Distributor or go to [www.Toro.com](http://www.Toro.com) for a list of all approved attachments and accessories.

# Operation

**Note:** Determine the left and right sides of the machine from the normal operating position.

## Think Safety First

Please carefully read all of the safety instructions and decals in the safety section. Knowing this information could help you or bystanders avoid injury.

## Checking the Engine Oil Level

Check the engine oil level before each use or every 8 operating hours, refer to Checking the Engine Oil Level.

## Filling the Fuel Tank

**Important:** Never use methanol, gasoline containing methanol, gasohol containing more than 10% ethanol, gasoline additives, premium gasoline, or white gas because the fuel system could be damaged. Do not mix oil with gasoline.

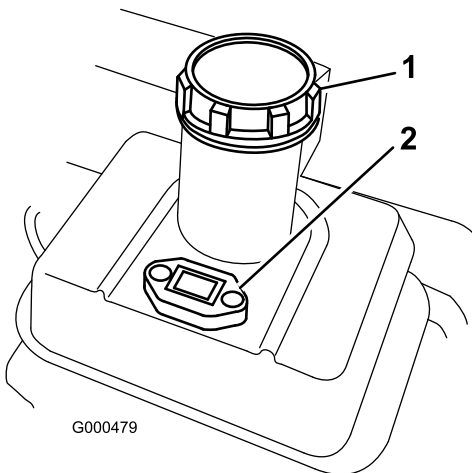

Figure 21

1. Fuel tank cap

2. Fuel gauge



**Gasoline is harmful or fatal if swallowed. Long-term exposure to vapors can cause serious injury and illness.**

- Avoid prolonged breathing of vapors.
- Keep face away from nozzle and gas tank or conditioner opening.
- Keep gas away from eyes and skin.



**In certain conditions, gasoline is extremely flammable and highly explosive. A fire or explosion from gasoline can burn you and others and can damage property.**

- Fill the fuel tank outdoors, in an open area, when the engine is cold. Wipe up any gasoline that spills.
- Do not fill the fuel tank completely full. Add gasoline to the fuel tank until the level is 1 inch (25 mm) below the bottom of the filler neck. This empty space in the tank allows gasoline to expand.
- Never smoke when handling gasoline, and stay away from an open flame or where gasoline fumes may be ignited by a spark.
- Store gasoline in an approved container and keep it out of the reach of children. Never buy more than a 30-day supply of gasoline.
- Always place gasoline containers on the ground away from your vehicle before filling.
- Do not fill gasoline containers inside a vehicle or on a truck or trailer bed because interior carpets or plastic truck bed liners may insulate the container and slow the loss of any static charge.
- When practical, remove gas-powered equipment from the truck or trailer and refuel the equipment with its wheels on the ground.
- If this is not possible, then refuel such equipment on a truck or trailer from a portable container, rather than from a gasoline dispenser nozzle.
- If a gasoline dispenser nozzle must be used, keep the nozzle in contact with the rim of the fuel tank or container opening at all times until fueling is complete.

1. Clean around fuel tank cap and remove cap from tank (Figure 21). Using unleaded gasoline, fill fuel tank no higher than to bottom of filter screen. Do not overfill.
2. Install fuel tank cap and wipe up any spilled gasoline.



# Checking the Interlock Switch Operation



If safety interlock switches are disconnected or damaged the machine could operate unexpectedly causing personal injury.

- Do not tamper with the interlock switches.
- Check the operation of the interlock switches daily and replace any damaged switches before operating the machine.

## Traction Interlock Switch

1. Push kick stand down with foot and pull up on handle support until kick stand has rotated forward, over center (Figure 22).

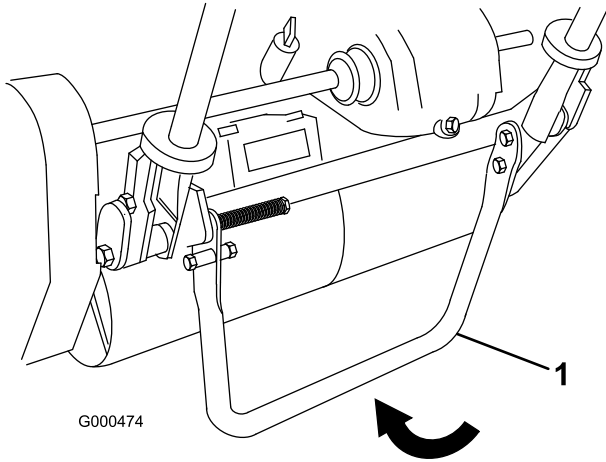

Figure 22

1. Kick stand
- 
2. Place traction lever into Engage position and engine controls in starting position.
  3. Attempt to start engine. Engine should not start. If engine starts, the interlock switch needs service. Correct the problem before operating. Refer to Servicing Interlock Switch.
  4. Carefully lift up on handle to release kick stand.

## Brake Interlock Switch

1. Push kick stand down with foot and pull up on handle support until kick stand has rotated forward, over center (Figure 22).
2. Start the engine.
3. Move the brake lever to the Engage position.

4. Move traction lever into Engage position, engine must shut off.
5. If the engine does not shut off, the interlock switch needs service. Correct the problem before operating.
6. Carefully lift up on handle to release kick stand.

## Starting and Stopping the Engine

**Note:** For illustrations and descriptions of the controls referenced in this section, refer to the Controls section in Operation.

### Starting the Engine

**Note:** Make sure spark plug wire is installed on spark plug.

1. Make sure traction and reel drive levers are in Disengaged position.  
**Note:** Engine will not start if traction lever is in the engaged position.
2. Open the fuel shut-off valve on the engine.
3. Move the on/off switch to the On position.
4. Move the throttle control to the Fast position.
5. Move the choke lever to the half-open position when starting a cold engine. The choke may not be required when starting a warm engine.
6. Pull the recoil starter handle out until positive engagement results, then pull it vigorously to start the engine. Open the choke as engine warms up.

**Important:** Do not pull recoil rope to its limit or let go of starter handle when rope is pulled out because rope may break or recoil assembly may be damaged.

### Stopping the Engine

1. Move the traction and reel drive controls to the Disengaged position, the throttle control to Slow, and the on/off switch to Off.
2. Pull the molded spark plug wire off of the spark plug to prevent the possibility of accidental starting before storing machine.
3. Close the fuel shut-off valve before storing or transporting mower in a vehicle.

## Transport Operation

**Note:** Do not run the mower engine while transporting it in a transport trailer because damage can occur to the mower.

If optional transport wheels are not going to be installed, proceed to step 4.

1. Push kick stand down with foot and pull up on handle support until kick stand has rotated forward, over center.
2. Install the transport wheels.
3. To release kickstand, pull up on handle and lower rear of mower onto transport wheels.
4. Ensure traction and reel drive controls are in Disengage position and start engine.
5. Set throttle control to Slow, tip front of machine up gradually engage traction drive and slowly increase engine speed.
6. Adjust throttle to operate mower at desired ground speed and transport mower to desired destination.

## Preparing to Mow

1. Return traction control lever to Disengage, throttle to Slow and stop engine.
2. Push kick stand down with foot and pull up on handle support until kick stand has rotated forward, over center.
3. Remove transport wheels.
4. Release kickstand.

## Mowing Operation

Proper use of the machine provides the smoothest turf cutting available.

**Important:** Grass clippings act as a lubricant when mowing. Excessive operation of the cutting unit with the absence of grass clippings can damage the cutting unit.

## Prior to Mowing

Be sure the mower is carefully adjusted and is set evenly on both sides of the reel. Improper mower adjustment is magnified in the appearance of the clipped turf. Remove all foreign objects from turf prior to mowing. Make sure everyone, especially children and pets, are clear of the work area.

## Method of Mowing

The greens should be mowed in a straight back and forth direction across the green. Avoid circular mowing or turning the mower on greens areas since scuffing may occur. Turning the mower should be done off the green by raising the cutting reel (pushing the handle down) and turning on the traction drum. Mowing should be done at a normal walking pace. Fast speeds saves very little time and will result in an inferior mowing job.

To assist in maintaining a straight line across the green and to keep the machine an equal distance from the edge of the previous cut, use the alignment stripes on the basket (Figure 23).

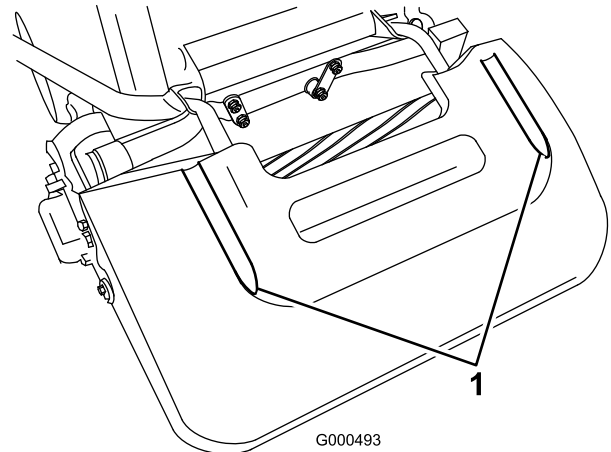

**Figure 23**

1. Alignment stripes

## Control Operation

To operate the controls while mowing:

1. Start the engine, set the throttle at reduced speed, push down on handle to raise cutting unit, move traction lever to Engaged position and transport mower onto collar of green (Figure 24).
2. Move traction lever to Disengaged position and Engage reel drive lever (Figure 24).

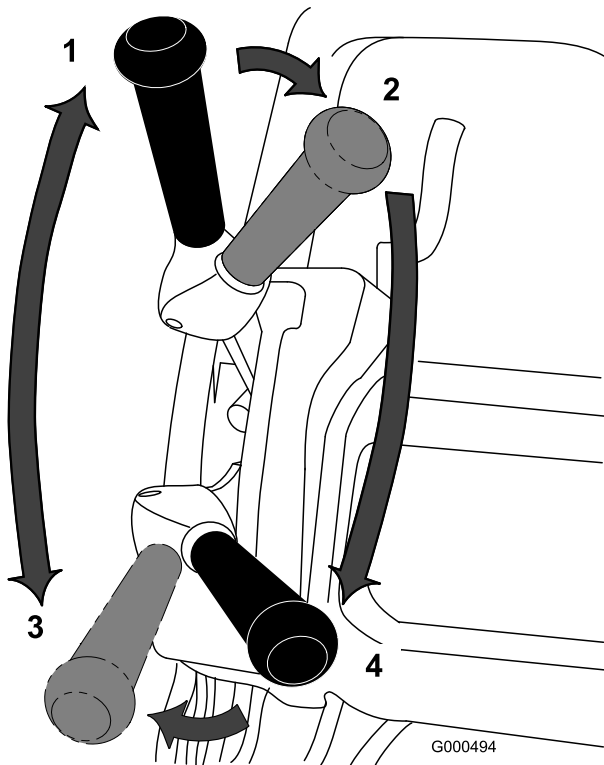

**Figure 24**

- |  |  |
|--|--|
| 1. Traction drive -neutral                 | 3. Traction drive-engaged (transport)  |
| 2. Traction drive neutral & reel drive off | 4. Traction drive & reel drive engaged |

- 
3. Move traction lever to Engaged position, increase throttle speed until the mower is traveling at the desired ground speed, drive the mower out onto the green area, lower the front of the mower down and commence operation (Figure 24).

## After Mowing

1. Drive off green, move reel drive and traction control levers to Disengage and stop the engine.
2. Empty the grass catcher of clippings, install grass catcher and commence transport operation.

# Maintenance

**Note:** Determine the left and right sides of the machine from the normal operating position.

## ***Recommended Maintenance Schedule(s)***

<b>Maintenance Service Interval</b>	<b>Maintenance Procedure</b>
After the first 8 hours	<ul style="list-style-type: none"><li>• Change the engine oil.</li></ul>
After the first 25 hours	<ul style="list-style-type: none"><li>• Clean the fuel filter.</li><li>• Change the transmission fluid.</li></ul>
Before each use or daily	<ul style="list-style-type: none"><li>• Check the engine oil level.</li></ul>
Every 25 hours	<ul style="list-style-type: none"><li>• Clean the air cleaner (more often in dirty or dusty conditions).</li></ul>
Every 50 hours	<ul style="list-style-type: none"><li>• Change the engine oil.</li><li>• Clean the fuel filter.</li><li>• Check the transmission fluid level.</li></ul>
Every 100 hours	<ul style="list-style-type: none"><li>• Check the paper air filter element and replace as required (more often in dirty or dusty conditions).</li><li>• Check the spark plug.</li></ul>
Every 800 hours	<ul style="list-style-type: none"><li>• Change the transmission fluid. (Or 2 years, whichever occurs first)</li></ul>
Before storage	<ul style="list-style-type: none"><li>• Paint chipped surfaces.</li></ul>

**Important:** Refer to your engine operator's manual for additional maintenance procedures.

# Daily Maintenance Checklist

**Important:** Duplicate this page for routine use.

Maintenance Check Item	For the week of:						
	Mon.	Tues.	Wed.	Thurs.	Fri.	Sat.	Sun.
Check the safety interlock operation.							
Check the parking brake operation.							
Check that pivot joints operate freely.							
Check the fuel level.							
Check the engine oil level.							
Check the air filter.							
Clean the engine cooling fins.							
Check for unusual engine noises.							
Check for unusual operating noises.							
Check the reel-to-bedknife adjustment.							
Check the height-of-cut adjustment.							
Touch up damaged paint.							

Notation for Areas of Concern		
Inspection performed by:		
Item	Date	Information

# Engine Maintenance

## Engine Oil

The crankcase must be filled with approximately 20 fluid ounces of proper viscosity oil before starting. The engine uses any high-quality oil having the American Petroleum Institute - API - "service classification" SF, SG, SH or SJ. Oil viscosity - weight - must be selected according to ambient temperature. Figure 25 illustrates the temperature/viscosity recommendations.

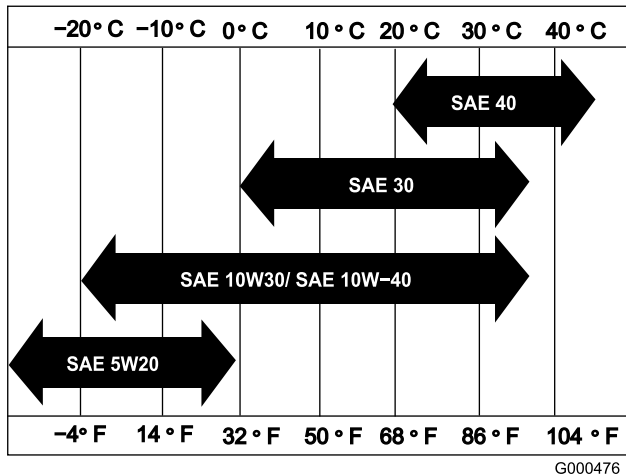

Figure 25

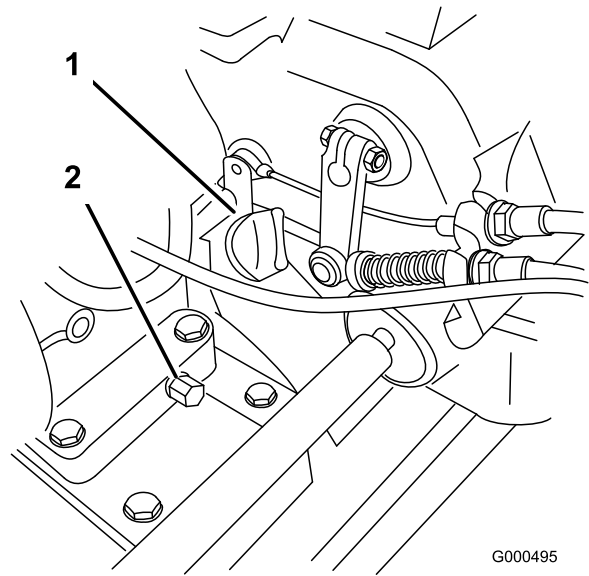

Figure 26

1. Oil level gauge
2. Drain plug

2. Remove oil level gauge by rotating it counterclockwise.
3. Wipe oil level gauge clean and insert it into filler port. Do not screw into port. Then remove and check level of oil. If level is low, add only enough oil to raise level until it is between the "H" and "L" marks on the gauge (Figure 27). Recheck level of oil. Do not overfill.

**Note:** Using multi-grade oils (5W-20, 10W-30, and 10W-40) will increase oil consumption. Check the oil level more frequently when using them.

## Checking the Engine Oil Level

**Service Interval:** Before each use or daily

**Note:** The best time to check the engine oil is when the engine is cool before it has been started for the day. If it has already been run, allow the oil to drain back down to the sump for at least 10 minutes before checking. If the oil level is at or below the "L" mark on the dipstick, add oil to bring the oil level to the "H" mark. **DO NOT OVERFILL.** If the oil level is between the "H" and "L" marks, no oil addition is required.

1. Remove the transport wheels (if installed), position the mower so the engine is level and clean around oil level gauge (Figure 26).

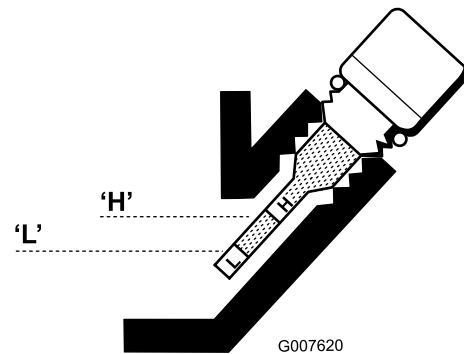

Figure 27

4. Reinstall oil level gauge and wipe up any spilled oil.

## Changing the Engine Oil

**Service Interval:** After the first 8 hours

Every 50 hours

1. Start and run engine for a few minutes to warm the engine oil.
2. Place a drain pan at rear of machine under drain plug (Figure 26). Remove drain plug.

3. Push down on handle to tip mower and engine backward, allowing all oil to run into drain pan.
4. Install drain plug and refill crankcase with the specified oil; refer to Checking the Oil Level.

## Servicing the Air Cleaner

**Service Interval:** Every 25 hours

Every 100 hours

1. Make sure wire is off spark plug.
2. Remove wing nuts securing air cleaner cover to air cleaner and remove cover. Clean cover thoroughly (Figure 28).

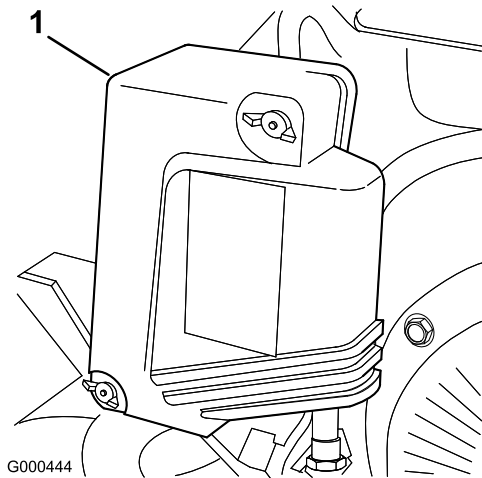

**Figure 28**

1. Air cleaner cover

3. If foam element is dirty, remove it from paper element (Figure 29). Clean thoroughly.
  - A. Wash foam element in a solution of liquid soap and warm water. Squeeze to remove dirt, but do not twist because the foam may tear.
  - B. Dry by wrapping in a clean rag. Squeeze rag and foam element to dry, but do not twist because the foam may tear.
  - C. Saturate element with clean engine oil. Squeeze element to remove excess oil and to distribute oil thoroughly. An oil damp element is desirable.

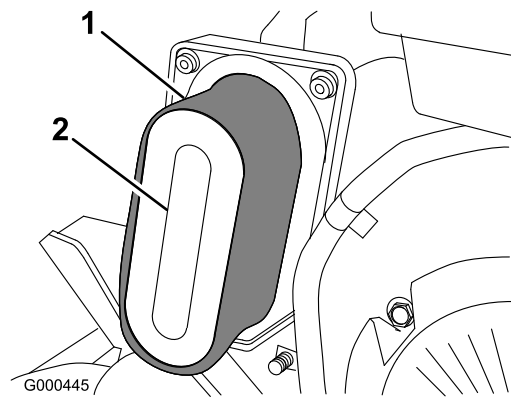

**Figure 29**

1. Foam element
2. Paper element

4. When servicing foam element, check condition of paper element. Replace as required.

**Note:** Do not use compressed air to clean the paper element.

5. Install foam element, paper element, and air cleaner cover.

**Important:** Do not operate the engine without the air cleaner element because extreme engine wear and damage will likely result.

## Replacing the Spark Plug

**Service Interval:** Every 100 hours

Use an NGK BPR 5ES spark plug or equivalent. Correct air gap is 0.028-0.032 inch.

1. Pull molded wire off spark plug (Figure 30).

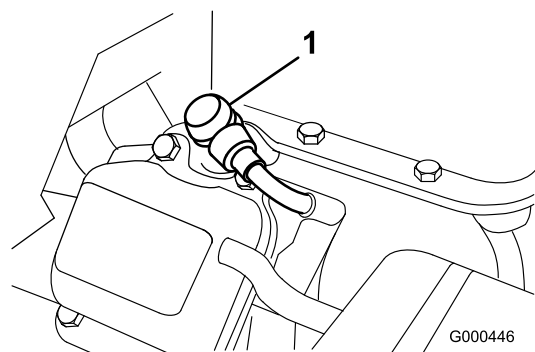

**Figure 30**

1. Spark plug wire

2. Clean around spark plug and remove plug from cylinder head.

**Important:** Replace a cracked, fouled, or dirty spark plug. Do not sand blast, scrape, or clean

electrodes because engine damaged could result from grit entering the cylinder.

3. Set air gap at 0.028-0.032 inch (Figure 31). Install correctly gapped spark plug and tighten firmly to 17 ft.-lb.

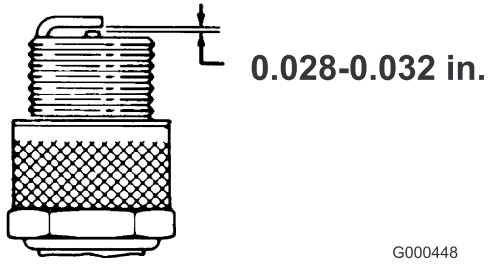

Figure 31

G000448

# Fuel System Maintenance

## Cleaning the Fuel Filter

**Service Interval:** After the first 25 hours  
Every 50 hours

1. Close fuel shut off valve and unscrew bowl from filter body (Figure 32).

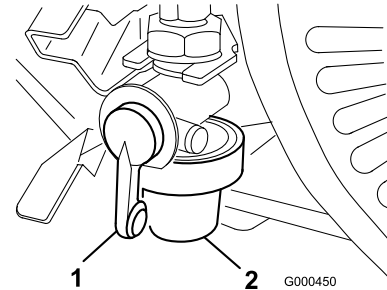

Figure 32

G000450

1. Shut-off valve
2. Bowl

2. Clean bowl and filter in clean gasoline and install.



# Electrical System Maintenance

## Servicing the Interlock Switch

Use the following procedure if the switch needs adjustment or replacement.

1. Make sure the engine is off and traction lever is Disengaged.
2. Engage traction lever until it contacts neutral stop (Figure 33).

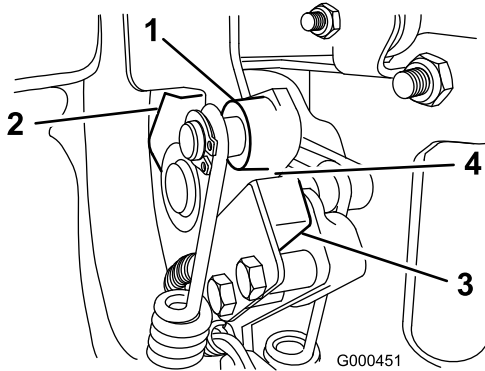

Figure 33

- |                   |                     |
|-------------------|---------------------|
| 1. Traction lever | 3. Interlock switch |
| 2. Neutral stop   | 4. .032" Gap        |

- 
3. Loosen interlock switch mounting fasteners (Figure 33).
  4. Place a .032" thick shim between the traction lever and the interlock switch (Figure 33).
  5. Tighten interlock switch mounting fasteners. Recheck gap. The traction lever must not contact the switch.
  6. Engage traction lever and verify that the switch loses continuity. Replace if required.

# Drive System Maintenance

## Checking the Transmission Fluid Level

**Service Interval:** Every 50 hours

The transmission is filled at the factory with approximately 94 fluid ounces of Mobil Dexron III automatic transmission fluid.

**Note:** The seals used in the transmission are internally lubricated with grease. During initial operation of mower, slight weeping of grease from these seals will occur. Wipe off excess grease.

**Important:** Use only Mobil Dexron III or equivalent transmission fluids. Other fluids could cause system damage.

1. Place the mower on its drums on a level surface.
2. Remove the check plug from the right-hand side of the transmission (Figure 34).

The oil level should come to the bottom of the fill hole. If it does not, remove the fill plug from the top of the transmission and add enough of the proper oil type until the level reaches the bottom of the check hole. Do not remove the vent pipe.

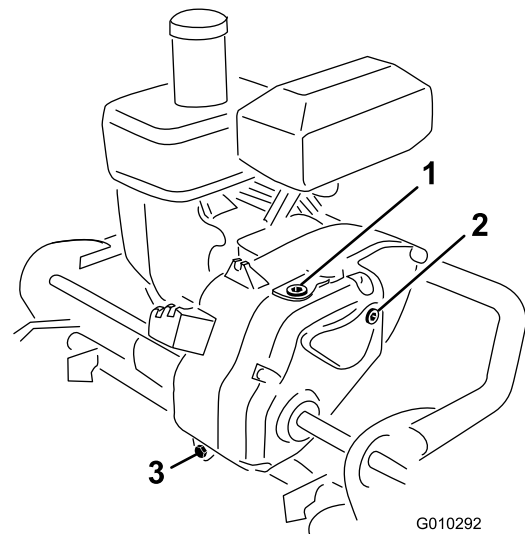

Figure 34

- |               |               |
|---------------|---------------|
| 1. Fill plug  | 3. Drain plug |
| 2. Check plug |               |

- 
3. Install the plugs.

# Changing the Transmission Fluid

**Service Interval:** After the first 25 hours

Every 800 hours (Or 2 years, whichever occurs first)

**Important:** Use only Mobil Dexron III or equivalent transmission fluids. Other fluids could cause system damage.

1. Place a drain pan at the rear of the machine.
2. Remove the drain plug from the rear of the transmission (Figure 35).

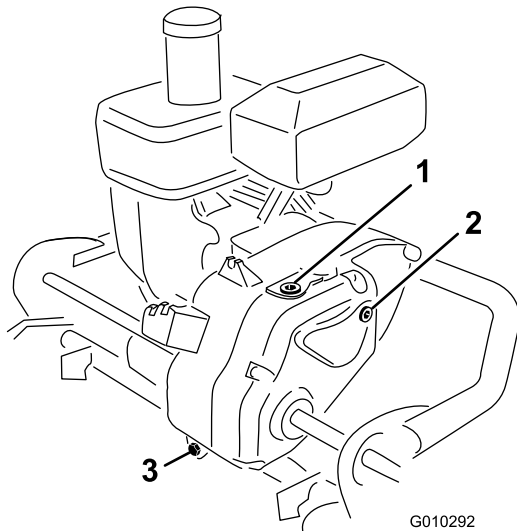

**Figure 35**

1. Fill plug
2. Check plug
3. Drain plug

3. Push down on the handle and tip the machine back. Remove the check plug from the right-hand side of the transmission (Figure 35).
4. When the fluid is drained, install the drain plug.
5. Place the mower on its drums on a level surface.
6. Remove the fill plug from the top of the transmission (Figure 35). Do not remove the vent pipe.
7. Fill the transmission with approximately 94 fluid ounces of the proper type of transmission fluid until the level reaches the bottom of the check hole; refer to Checking the Transmission Fluid.
8. Install the fill and check plugs.

# Brake Maintenance

## Adjusting the Service/Parking Brake

If service/park brake slips when operated, an adjustment is required.

1. Move service/parking brake lever to Off position.
2. To increase cable tension, loosen front cable jam nut and tighten back cable jam nut (Figure 36) until a force of 11–14 lb. is required to engage brake. Force to be measured at lever knob. Do not over adjust, or brake band may drag.

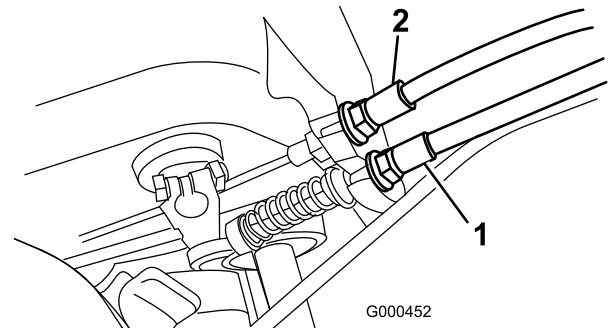

**Figure 36**

1. Traction cable
2. Service/parking brake cable

# Belt Maintenance

## Adjusting the Belts

Make sure belts are properly tensioned to assure proper operation of the machine and unnecessary wear. Check belts frequently.

### Reel Drive Belt (Reel)

1. Remove the belt cover mounting fasteners and belt cover to expose belt (Figure 37).

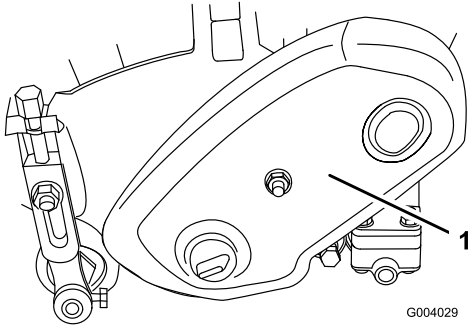

**Figure 37**

1. Belt cover

2. Check tension by depressing belt (Figure 38) at mid span of pulleys with  $4 \pm 1$  lb. of force. Belt should deflect  $3/16$  to  $5/16$  inch (4.8 to 7.9 mm). If the deflection is incorrect, proceed to next step.

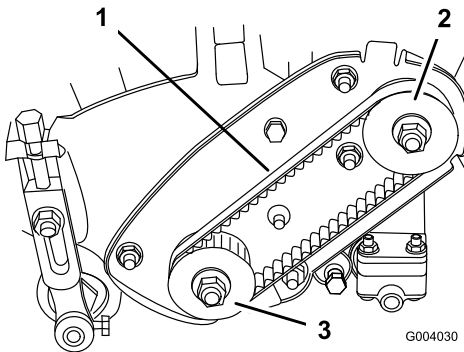
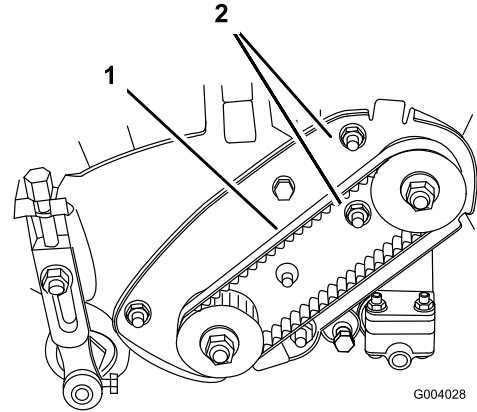

**Figure 38**

1. Reel drive belt
2. Drive pulley
3. Driven pulley

3. To adjust belt tension:

- A. Loosen the bearing housing mounting nuts (Figure 39).



**Figure 39**

1. Reel drive belt
2. Bearing housing mounting nuts

- B. Using a  $3/8$  inch drive torque wrench, rotate the bearing housing with 35-40 in.-lb. of torque to set belt tension (Figure 40)

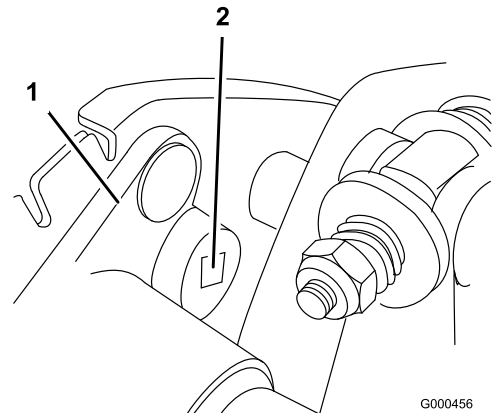

**Figure 40**

1. Bearing housing
2.  $3/8$ " Torque wrench here

- C. While holding the torque wrench setting, tighten the bearing housing mounting nuts (Figure 39). Do not over-tension belt.

- D. Install belt cover.

## Reel Drive Belt (Transmission coupler)

1. Remove the belt cover mounting fasteners and belt cover to expose belt (Figure 41).

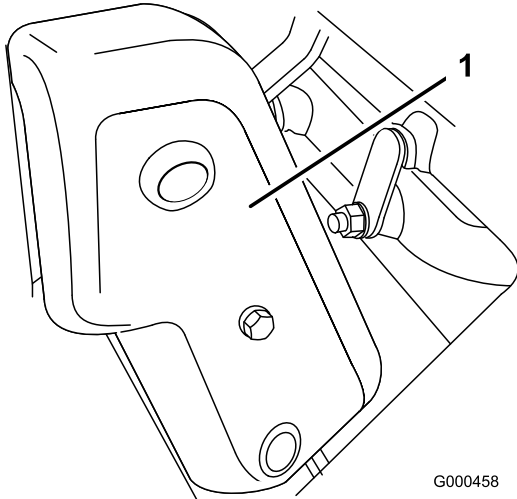

**Figure 41**

1. Belt cover

2. Check tension by depressing belt (Figure 42) at mid span of pulleys with  $4 \pm 1$  lb. of force. Belt should deflect  $3/16$  to  $5/16$  inch (4.8 to 7.9 mm). If the deflection is incorrect, proceed to next step.

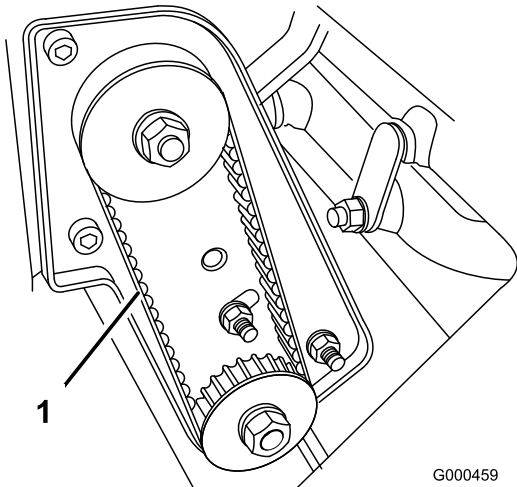
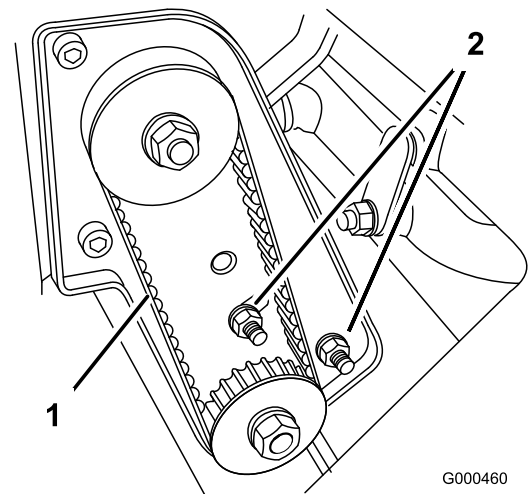

**Figure 42**

1. Reel drive belt

3. To adjust belt tension:

- A. Loosen the bearing housing mounting nuts (Figure 43).



**Figure 43**

1. Reel drive belt
2. Bearing housing mounting nuts

- B. Using a  $3/8$  inch drive torque wrench, rotate the bearing housing with 35-40 in.-lb. of torque to set belt tension (Figure 44).

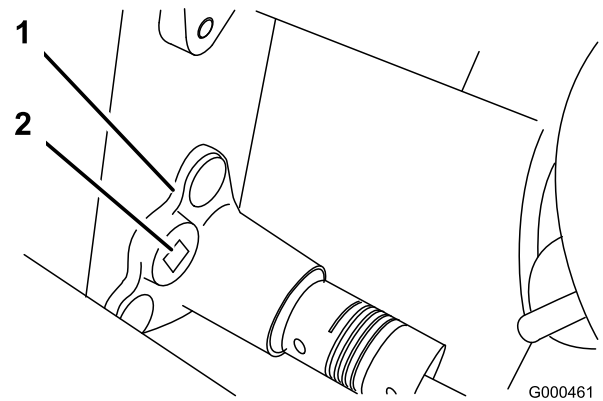

**Figure 44**

1. Bearing housing
2.  $3/8$ " Torque wrench here

- C. While holding the torque wrench setting, tighten the bearing housing mounting nuts (Figure 43). Do not over-tension belt.

- D. Install belt cover.

## Traction Drive Belt

1. Remove belt cover mounting fasteners and belt cover to expose belt (Figure 45).

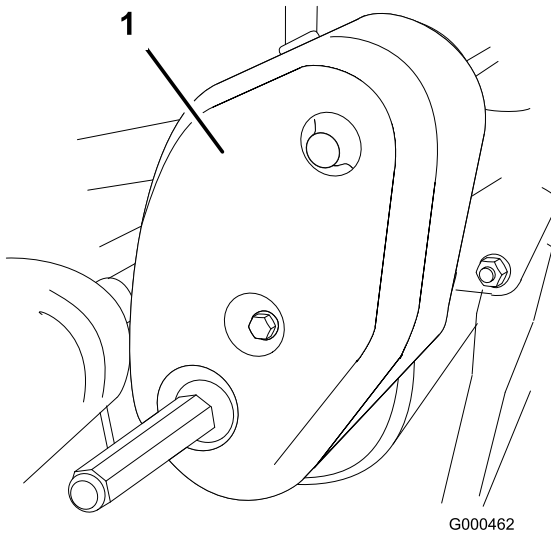

**Figure 45**

1. Traction drive belt cover

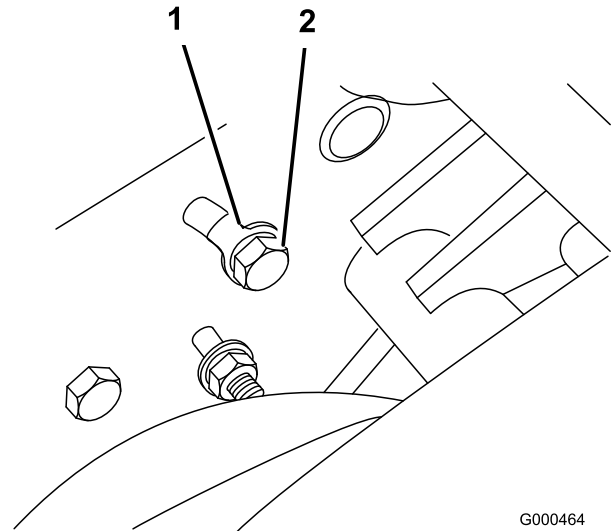

**Figure 47**

1. Tang washer
2. Idler bracket bolt

2. Check tension by depressing belt (Figure 46) at mid span of pulleys with  $4 \pm 1$  lb of force. Belt should deflect  $3/16$  to  $5/16$  inch (4.8 to 7.9 mm). If the deflection is incorrect, proceed to next step.

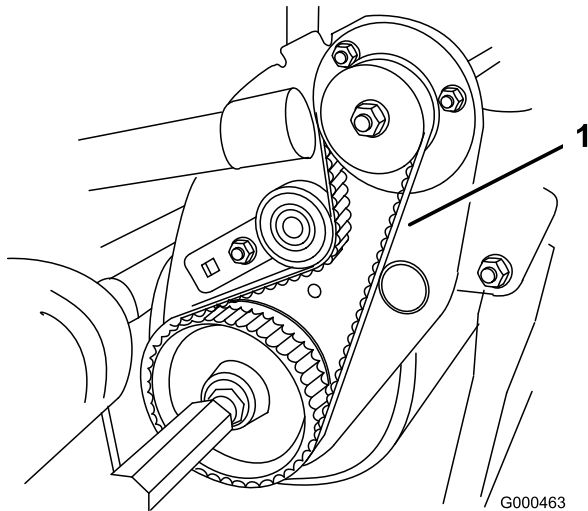

**Figure 46**

1. Traction drive belt

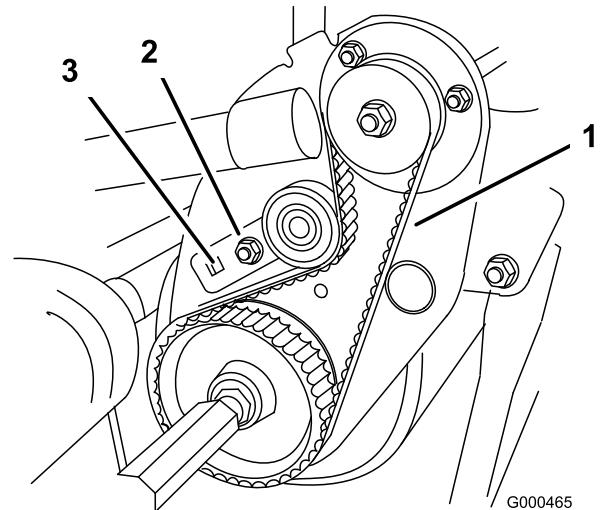

**Figure 48**

1. Traction drive belt
2. Idler bracket
3. 3/8 inch Torque wrench here

3. To adjust belt tension:

- A. On back side of side plate, loosen the bolt securing the idler bracket to the side plate (Figure 47).

- C. Install the belt cover.

# Controls System Maintenance

## Adjusting the Traction Control

If traction control does not engage or it slips during operation, an adjustment is required.

1. Move traction control to Disengaged position.
2. To increase cable tension, loosen front cable jam nut and tighten back cable jam nut (Figure 49) until a force of 10-13 lbs. is required to engage traction control.

Measure the force at the control knob.

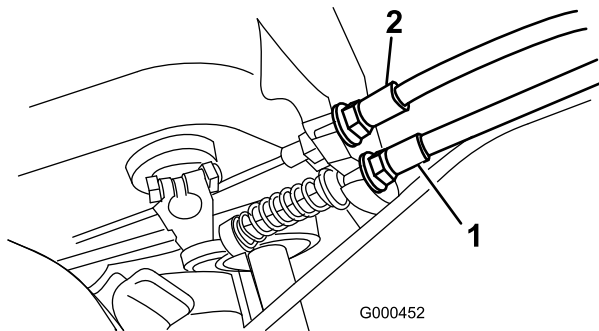

Figure 49

1. Traction cable
2. Service/parking brake cable

3. Tighten front cable jam nut.
4. Check control operation.

## Adjusting the Reel Control

If reel control does not engage or it slips during operation, an adjustment is required.

1. Make sure traction control is properly adjusted; refer to Adjusting the Traction Control.
2. To increase cable tension, loosen front cable jam nut and tighten back cable jam nut (Figure 50) (located on top of gear box) until the reel cable force adds 7 to 10 lbs. of additional handle force measured at the control knob.

**Note:** If traction control handle force is 12 lbs., the combined traction and reel force should be 19 to 22 lbs.

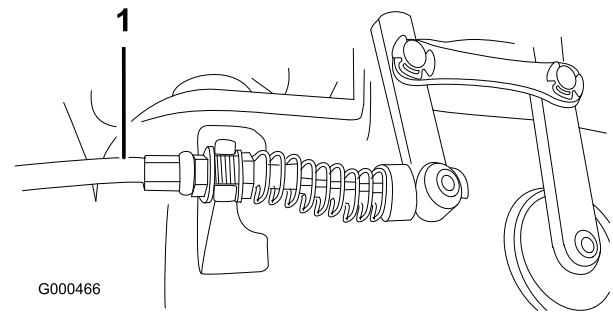

Figure 50

1. Reel control cable
3. Tighten front cable jam nut.
4. Check control operation.

# Cutting Unit Maintenance

## Separating the Cutting Unit from the Traction Unit

1. Place the mower on its drums on a level surface.
2. Lower kick stand. Insert a 1/4" dia. pin or equivalent into frame hole above kick stand mounting bolt (Figure 51).

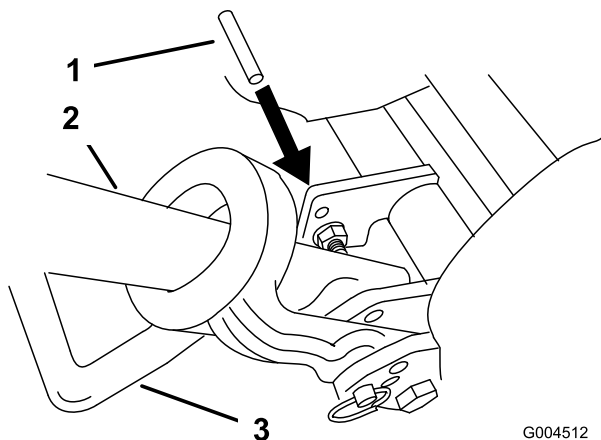

Figure 51

1. 1/4" Pin
2. Handle
3. Kick stand

3. Remove grass basket.
4. Remove (2) bolts securing cutting unit pivot arms to traction unit frame tube (Figure 52).

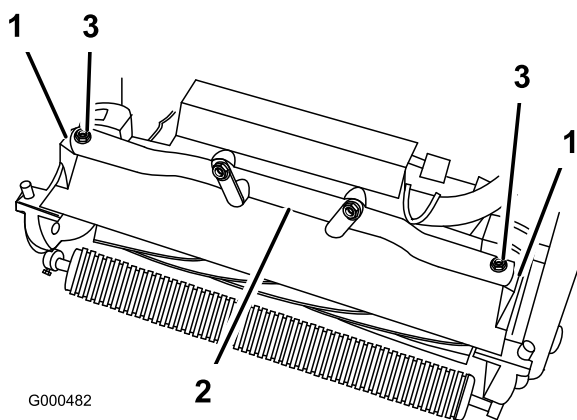

Figure 52

1. Cutting unit pivot arms
2. Traction unit frame tube
3. Bolts

5. Rotate pivot arms forward (Figure 52) and rest traction unit on restrained kickstand.
6. Pull cutting unit forward about 2 inch (51 mm) and then to the right to disengage the transmission coupling (Figure 53).

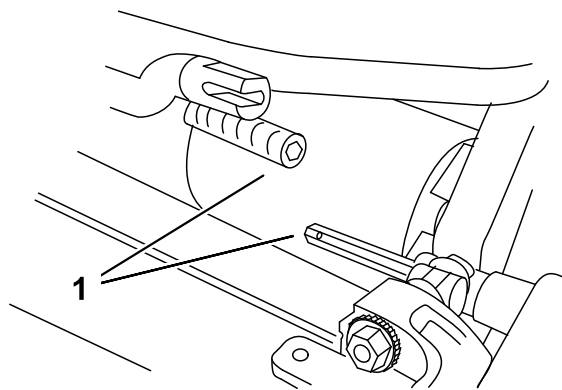

Figure 53

1. Transmission coupling

7. Reverse procedure to install cutting unit.

**Note:** When tightening the pivot arm mounting fasteners, use an adjustable end wrench to hold the pivot arm parallel to the side plate (Figure 54).

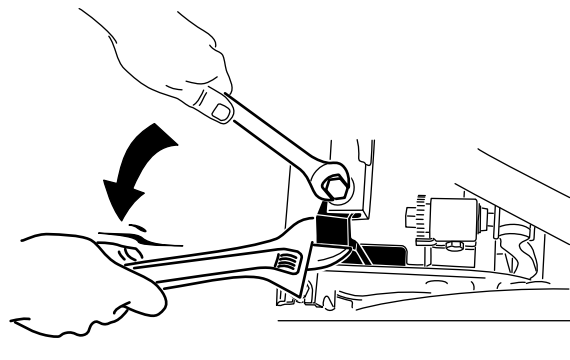
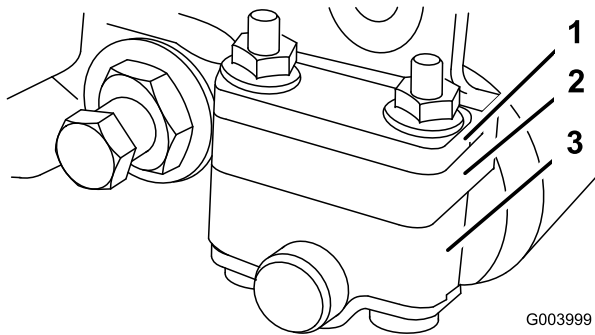

Figure 54

## Adjusting the Rear Roller

1. Adjust the rear roller brackets to the low or high position depending on desired height of cut range (Figure 55 and Figure 56).
  - Position the spacer above the sideplate mounting flange (factory setting) when height of cut settings range from 1/16 to 1/4" (Fig. 10).



**Figure 55**

1. Spacer
2. Sideplate mounting flange
3. Roller bracket

- Position the spacer below the sideplate mounting flange when height of cut settings range from 1/8" to 1" (Figure 56).

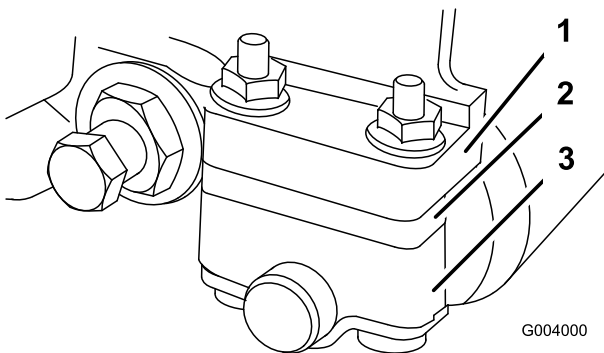
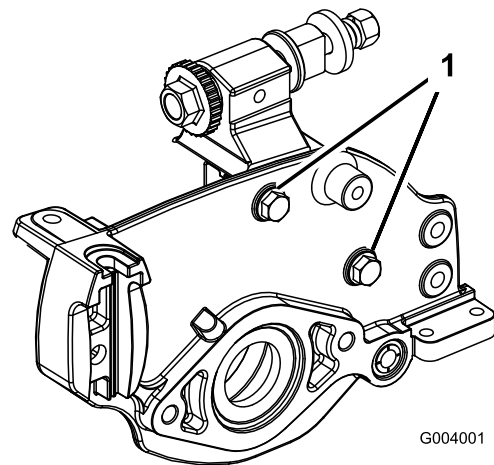

**Figure 56**

1. Sideplate mounting flange
2. Spacer
3. Roller bracket

2. To adjust rear roller proceed as follows:
  - Raise rear of cutting unit and place a block under bedknife.
  - Remove (2) nuts securing each roller bracket and spacer to each sideplate mounting flange.
  - Lower roller and screws from sideplate mounting flanges and spacers.
  - Place spacers onto screws on roller brackets.
  - Re-secure roller bracket and spacers to underside of sideplate mounting flanges with nuts previously removed.
3. Verify that the bedknife to reel contact is correct. Tip mower to expose front and rear rollers and bedknife.

**Note:** The position of the rear roller to the reel is controlled by the machining tolerances of the assembled components and paralleling is not required. A limited amount of adjustment is possible by setting the cutting unit on a surface plate and loosening the sideplate mounting bolts (Figure 57). Adjust and re-tighten bolts.



**Figure 57**

1. Sideplate mounting bolts

**Important:** Whenever the cutting unit has to be tipped to expose bedknife/reel, prop up rear of cutting unit to make sure nuts on back end of bedbar adjusting screws are not resting on work surface.

## Adjusting the Bedknife to the Reel

Bedknife to reel adjustment is accomplished by loosening or tightening bedbar adjusting screws, located on top of mower.

1. Position machine on a flat, level work surface.
2. Make sure reel contact is removed by turning bedbar adjusting screws counterclockwise (Figure 58).

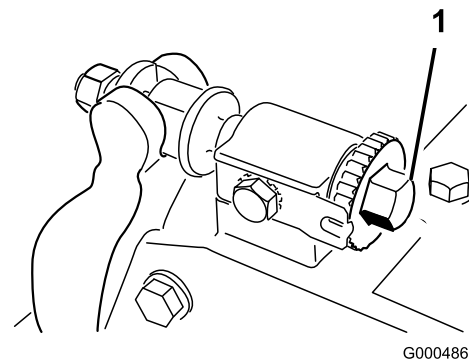

**Figure 58**

1. Bedbar adjusting screw

3. Tilt mower on back to expose bedknife and reel.
4. At one end of reel, insert a long strip of newspaper between reel and bedknife (Figure 59). While slowly rotating reel forward, turn bedbar adjusting screw clockwise (on same end of reel) (Figure 58), one click at a time, until paper is pinched lightly, when inserted



from the front, parallel to the bedknife. A slight drag will be noted as the paper is pulled.

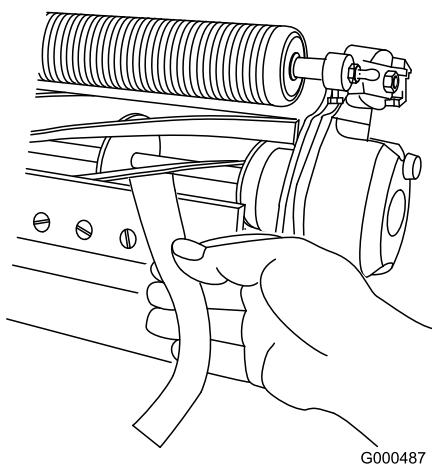

Figure 59

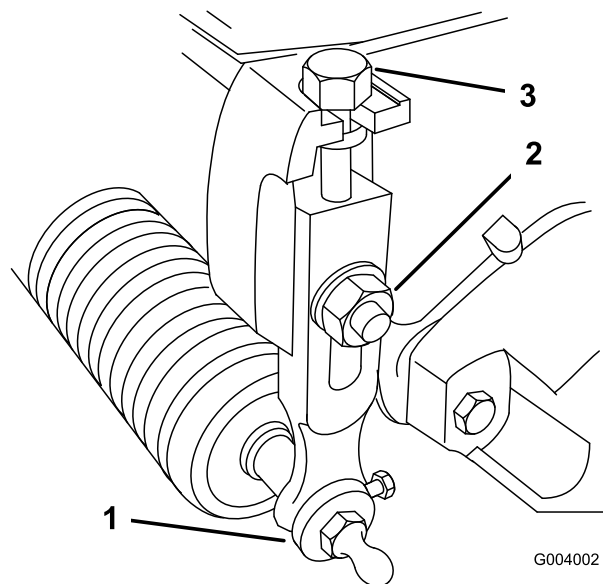

Figure 60

- |                        |                    |
|------------------------|--------------------|
| 1. Rear roller bracket | 3. Locknut         |
| 2. Height-of-cut arm   | 4. Adjusting screw |

**Note:** Each time adjusting screw is rotated one click clockwise, the bedknife moves .0007 inch closer to reel. Do not overtighten the adjusting screws.

5. Check for light contact at other end of reel using paper and adjust as required.
6. After adjustment is accomplished, check to see if reel can pinch paper when inserted from the front and cut paper when inserted at a right angle to the bedknife (Figure 59). It should be possible to cut paper with minimum contact between the bedknife and the reel blades. Should excessive reel drag be evident it will be either necessary to backlap or regrind the cutting unit to achieve the sharp edges needed for precision cutting (see Toro reel sharpening manual).

## Adjusting the Height of Cut

For heights of cut greater than .500", the high height of cut kit must be installed.

1. Loosen locknuts securing height-of-cut arms to cutting unit side plates (Figure 60).

2. Loosen nut on gauge bar (Figure 61) and set adjusting screw to desired height-of-cut. Distance between bottom of screw head and face of bar is height-of-cut.

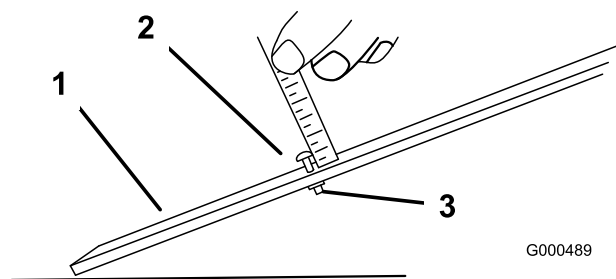
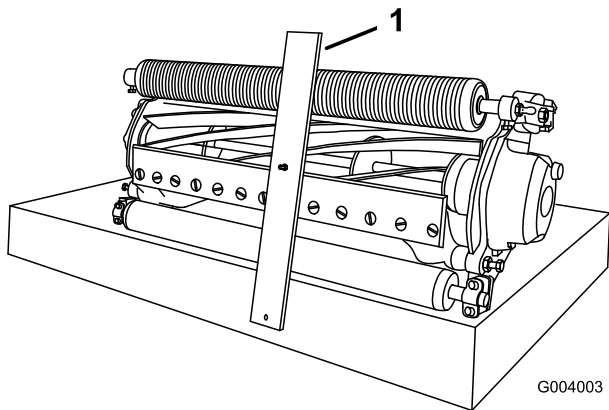

Figure 61

- |                           |        |
|---------------------------|--------|
| 1. Gauge bar              | 3. Nut |
| 2. Height adjusting screw |        |

3. Hook screw head on cutting edge of bedknife and rest rear end of bar on rear roller (Figure 62).
4. Rotate adjusting screw until roller contacts front of gauge bar. Adjust both ends of roller until entire roller is parallel to the bedknife.

**Important:** When set properly, the rear and front rollers will contact the gauge bar and the screw will be snug against the bedknife. This ensures that the height-of-cut is identical at both ends of the bedknife.



**Figure 62**

5. Tighten nuts to secure adjustment. Do not overtighten nut. Tighten enough to remove play from washer.

**Note:** Use the following chart to determine which bedknife is best suited for the desired height of cut.

## Adjusting the Cut-Off Bar

Adjust cut-off bar to assure clippings are cleanly discharged from the reel area:

1. Loosen screws securing top bar (Figure 63) to cutting unit.

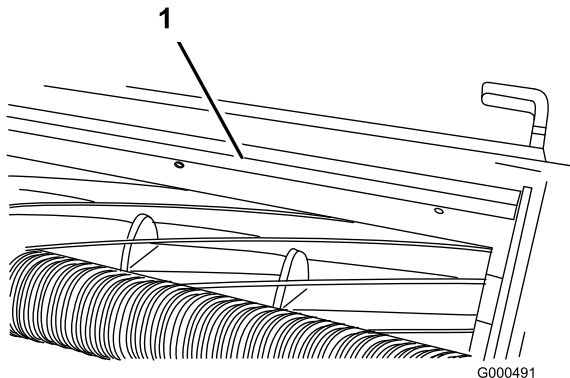

**Figure 63**

1. Cut-off bar

2. Insert .060 inch feeler gauge between top of reel and bar and tighten screws. Ensure bar and reel are equal distance apart across complete reel.

**Note:** The bar is adjustable to compensate for changes in turf conditions. The bar should be adjusted closer to reel when turf is extremely dry. By contrast, adjust bar further away from reel when turf conditions are wet. The bar should be parallel to reel to ensure optimum performance and should be adjusted whenever reel is sharpened on a reel grinder.

# Setting the Machine to Match Turf Conditions

**Note:** Use the following table to set the machine to match turf conditions.

Flex Greensmower Cutting Unit Set-up Matrix				
<b>Bedbars: Standard and Optional</b>				
Part Number	Description	Mower	Aggressiveness	Comments
106-2468-01	Standard	Flex 21	Less	Standard
99-3794-03	Aggressive	Flex 21	More	
110-2282-01	Standard	Flex 18	Less	Standard
110-2281-03	Aggressive	Flex 18	More	
<b>Bedknives: Standard and Optional</b>				
Part Number	Description	Mower	Height of Cut Range	Comments
93-4262	Microcut	Flex 21	0.062 - 0.125 inches	Standard (11 Blade)
115-1880	EdgeMax Microcut	Flex 21	0.062 - 0.125 inches	Standard (14 Blade)
93-4263	Tournament	Flex 21	0.125 -0.250 inches	
115-1881	EdgeMax Tournament	Flex 21	0.125 -0.250 inches	Longer Wearing
93-4264	Low Cut	Flex 21	0.250 inches and up	
108-4303	Extended Microcut	Flex 21	0.062 - 0.125 inches	Less Aggressive
98-7261	Microcut	Flex 18	0.062 - 0.125 inches	Standard (11 Blade)
117-1530'	EdgeMax Microcut	Flex 18	0.062 - 0.125 inches	Standard (14 Blade)
98-7260	Tournament	Flex 18	0.125 -0.250 inches	
117-1532'	EdgeMax Tournament	Flex 18	0.125 -0.250 inches	Longer Wearing
110-2300	Extended Microcut	Flex 18	0.062 - 0.125 inches	Less Aggressive
110-2301	Low Cut	Flex 18	0.250 inches and up'	
<b>Rollers: Standard and Optional</b>				
Part Number	Description	Mower	Diameter/Material	Comments
107-9037	Narrow Wiehle	Flex 21	2.5 inches Aluminum	Standard Front
107-9038	Wide Wiehle	Flex 21	2.5 inches Aluminum	More Penetration
107-9039	Full Roller	Flex 21	2.5 inches Steel	Least Penetration
107-9036	Rear Roller	Flex 21	2.0 inches Aluminum	Standard Rear
106-6945	Rear Roller	Flex 21	2.0 inches Steel	Steel Rear
93-9045	Anti Scalp Wiehle	Flex 21	2.5 inches Aluminum 1-7/8 inches longer	More edge support
110-2304	Narrow Wiehle	Flex 18	2.5 inches Aluminum	Standard Front
110-2305	Wide Wiehle	Flex 18	2.5 inches Aluminum	More Penetration
110-2306	Full Roller	Flex 18	2.5 inches Steel	Least Penetration
110-2303	Rear Roller	Flex 18	2.0 inches Aluminum	Standard Rear

**Note:** Use the following table and Figure 64 to set the rate of clip.

Clip (Refer to Figure 64 for pulley locations.)				
Drive pulley number of teeth	Driven pulley number of teeth	14 Blade Clip inch (mm)	11 Blade Clip inch (mm)	8 Blade Clip inch (mm)
27 (standard)	22 (standard)	0.112 (2.9)	0.143 (3.6)	0.197 (5.0)
22	22	0.138 (3.5)	0.176 (4.5)	0.241 (6.1)
22	27	0.172 (4.4)	0.219 (5.6)	0.301 (7.7)

The reel is shipped with one 27 tooth and one 22 tooth pulley. To get a .16 inch clip, you must purchase a 22 tooth pulley. The clip can only be changed on the reel drive (Figure 64). Do not change the drive ratio on the gearbox pulleys.

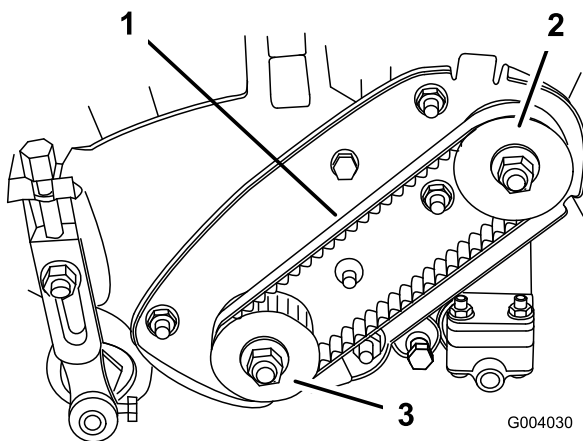

**Figure 64**

- 1. Reel drive belt
- 2. Drive pulley
- 3. Driven pulley

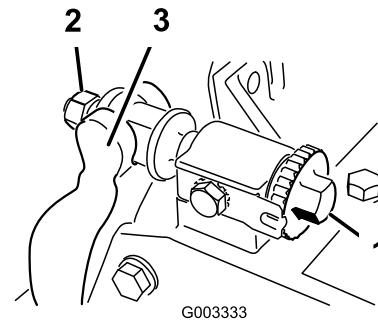

**Figure 65**

- 1. Bedbar adjusting screw
- 2. Spring tension nut
- 3. Bedbar
- 4. Jam nut
- 5. Bedbar bolt

2. Back out the spring tension nut, until the washer is no longer tensioned against the bedbar (Figure 66).
3. On each side of the machine, loosen the jam nut securing the bedbar bolt (Figure 66).

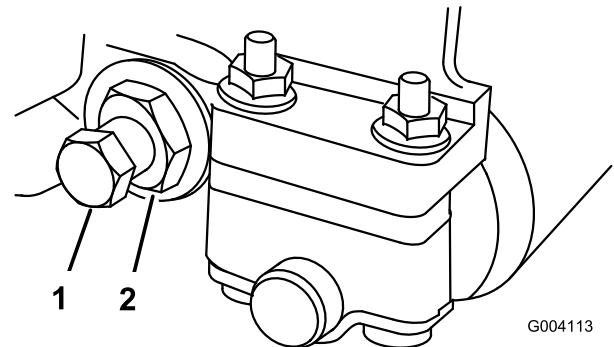

**Figure 66**

- 1. Bedbar bolt
- 2. Nut

## Servicing the Bedbar

### Removing the Bedbar

1. Turn the bedbar adjuster screw, counterclockwise, to back the bedknife away from reel (Figure 65).

4. Remove each bedbar bolt allowing bedbar to be pulled downward and removed from machine. Account for 2 nylon and 2 stamped steel washers on each end of bedbar (Figure 67).

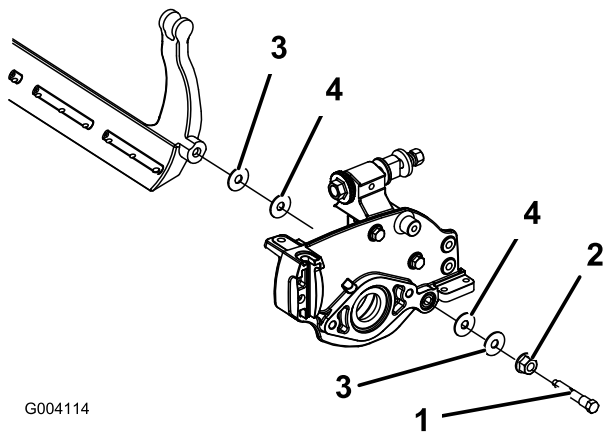

**Figure 67**

- |                 |                 |
|-----------------|-----------------|
| 1. Bedbar bolt  | 3. Nut          |
| 2. Steel washer | 4. Nylon washer |

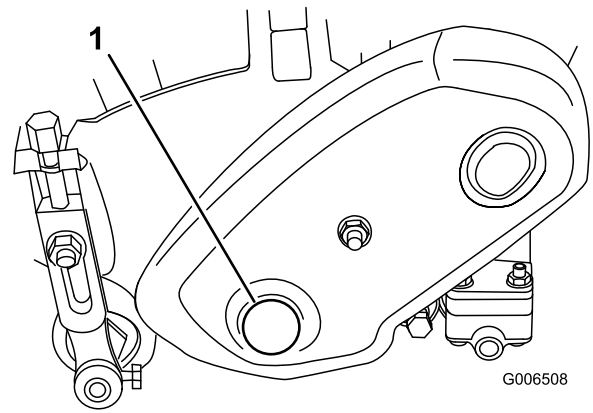

**Figure 68**

1. Reel drive cover plug

## Assembling the Bedbar

1. Install bedbar, positioning mounting ears between washer and bedbar adjuster.
2. Secure bedbar to each side plate with bedbar bolts (jam nuts on bolts) and 8 washers. A nylon washer is to be positioned on each side of side plate boss. Place a steel washer outside each of the nylon washers. Torque bolts to 240-320 in.-lb.
3. Tighten the jam nut until the end play is removed from the outside thrust washers. Do not overtighten.

**Note:** It is acceptable that the inside thrust washers on the cutting unit may remain loose.

4. Tighten spring tension nut until spring is collapsed, then back off 1/2 turn.
5. Adjust bedbar; refer to Adjusting the Bedknife to the Reel.

## Backlapping the Reel

1. Remove plug from the reel drive cover on the left side of reel assembly (Figure 68)

2. Insert a 18 mm socket onto hex flange nut on left end of reel shaft.
3. Backlap according to the procedure in the Toro Sharpening Reel and Rotary Mowers Manual, Form No. 80-300 PT.



**Contact with the reel or other moving parts can result in personal injury.**

- Stay away from the reel while backlapping.
- Never use a short handled paint brush for backlapping. Part No. 29-9100 Handle assembly complete or individual parts are available from your local Authorized Toro Distributor.

**Note:** For a better cutting edge, run a file across the front face of the bedknife when the lapping operation is completed. This will remove any burrs or rough edges that may have built up on the cutting edge.

4. Reinstall plug when backlap operation is completed.

# Storage

1. Remove grass clippings, dirt, and grime from the external parts of the entire machine, especially the engine. Clean dirt and chaff from the outside of the engine's cylinder head fins and blower housing.

**Important:** You can wash the machine with mild detergent and water. Do not pressure wash the machine. Avoid excessive use of water, especially near the shift lever plate, and engine.

2. For long-term storage (more than 90 days) add stabilizer/conditioner additive to fuel in the tank.
  - A. Run the engine to distribute conditioned fuel through the fuel system (5 minutes).
  - B. Either stop engine, allow it to cool, and drain the fuel tank, or operate the engine until it stops.
  - C. Restart the engine and run it until it stops. Repeat, on Choke, until the engine will not restart.
  - D. Dispose of fuel properly. Recycle as per local codes.

**Note:** Do not store stabilizer/conditioned gasoline over 90 days.

3. Check and tighten all bolts, nuts, and screws. Repair or replace any part that is damaged or defective.
4. Paint all scratched or bare metal surfaces. Paint is available from your Authorized Service Dealer.
5. Store the machine in a clean, dry garage or storage area. Cover the machine to protect it and keep it clean.

**Notes:**



## Toro General Commercial Products Warranty

### A Two-Year Limited Warranty

#### Conditions and Products Covered

The Toro Company and its affiliate, Toro Warranty Company, pursuant to an agreement between them, jointly warrant your Toro Commercial Product ("Product") to be free from defects in materials or workmanship for two years or 1500 operational hours\*, whichever occurs first. This warranty is applicable to all products with the exception of Aerators (refer to separate warranty statements for these products). Where a warrantable condition exists, we will repair the Product at no cost to you including diagnosis, labor, parts, and transportation. This warranty begins on the date the Product is delivered to the original retail purchaser.

\* Product equipped with hour meter

#### Instructions for Obtaining Warranty Service

You are responsible for notifying the Commercial Products Distributor or Authorized Commercial Products Dealer from whom you purchased the Product as soon as you believe a warrantable condition exists. If you need help locating a Commercial Products Distributor or Authorized Dealer, or if you have questions regarding your warranty rights or responsibilities, you may contact us at:

Toro Commercial Products Service Department  
Toro Warranty Company  
8111 Lyndale Avenue South  
Bloomington, MN 55420-1196  
952-888-8801 or 800-952-2740  
E-mail: commercial.warranty@toro.com

#### Owner Responsibilities

As the Product owner, you are responsible for required maintenance and adjustments stated in your *Operator's Manual*. Failure to perform required maintenance and adjustments can be grounds for disallowing a warranty claim.

#### Items and Conditions Not Covered

Not all product failures or malfunctions that occur during the warranty period are defects in materials or workmanship. This warranty does not cover the following:

- Product failures which result from the use of non-Toro replacement parts, or from installation and use of add-on, or modified non-Toro branded accessories and products. A separate warranty may be provided by the manufacturer of these items.
- Product failures which result from failure to perform recommended maintenance and/or adjustments. Failure to properly maintain your Toro product per the Recommended Maintenance listed in the *Operator's Manual* can result in claims for warranty being denied.
- Product failures which result from operating the Product in an abusive, negligent or reckless manner.
- Parts subject to consumption through use unless found to be defective. Examples of parts which are consumed, or used up, during normal Product operation include, but are not limited to, brake pads and linings, clutch linings, blades, reels, rollers and bearings (sealed or greasable), bed knives, aerator crankshaft and stomper arm bearings, tines, spark plugs, castor wheels and bearings, tires, filters, belts, and certain sprayer components such as diaphragms, nozzles, and check valves, etc.

- Failures caused by outside influence. Conditions considered to be outside influence include, but are not limited to, weather, storage practices, contamination, use of unapproved coolants, lubricants, additives, fertilizers, water, or chemicals, etc.
- Normal noise, vibration, wear and tear, and deterioration.
- Normal "wear and tear" includes, but is not limited to, damage to seats due to wear or abrasion, worn painted surfaces, scratched decals or windows, etc.

#### Parts

Parts scheduled for replacement as required maintenance are warranted for the period of time up to the scheduled replacement time for that part. Parts replaced under this warranty are covered for the duration of the original product warranty and become the property of Toro. Toro will make the final decision whether to repair any existing part or assembly or replace it. Toro may use remanufactured parts for warranty repairs.

#### Note Regarding Deep Cycle Battery Warranty:

Deep cycle batteries have a specified total number of kilowatt-hours they can deliver during their lifetime. Operating, recharging, and maintenance techniques can extend or reduce total battery life. As the batteries in this product are consumed, the amount of useful work between charging intervals will slowly decrease until the battery is completely worn out. Replacement of worn out batteries, due to normal consumption, is the responsibility of the product owner. Battery replacement may be required during the normal product warranty period at owner's expense.

#### Maintenance is at Owner's Expense

Engine tune-up, lubrication cleaning and polishing, replacement of filters, coolant, and completing recommended maintenance are some of the normal services Toro products require that are at the owner's expense.

#### General Conditions

Repair by an Authorized Toro Distributor or Dealer is your sole remedy under this warranty.

**Neither The Toro Company nor Toro Warranty Company is liable for indirect, incidental or consequential damages in connection with the use of the Toro Products covered by this warranty, including any cost or expense of providing substitute equipment or service during reasonable periods of malfunction or non-use pending completion of repairs under this warranty. Except for the Emissions warranty referenced below, if applicable, there is no other express warranty. All implied warranties of merchantability and fitness for use are limited to the duration of this express warranty.**

Some states do not allow exclusions of incidental or consequential damages, or limitations on how long an implied warranty lasts, so the above exclusions and limitations may not apply to you. This warranty gives you specific legal rights, and you may also have other rights which vary from state to state.

#### Note regarding engine warranty:

The Emissions Control System on your Product may be covered by a separate warranty meeting requirements established by the U.S. Environmental Protection Agency (EPA) and/or the California Air Resources Board (CARB). The hour limitations set forth above do not apply to the Emissions Control System Warranty. Refer to the Engine Emission Control Warranty Statement supplied with your product or contained in the engine manufacturer's documentation for details.

#### Countries Other than the United States or Canada

Customers who have purchased Toro products exported from the United States or Canada should contact their Toro Distributor (Dealer) to obtain guarantee policies for your country, province, or state. If for any reason you are dissatisfied with your Distributor's service or have difficulty obtaining guarantee information, contact the Toro importer.