



# 53cm Super Bagger Lawn Mower

Model No. 20899—Serial No. 310000001 and Up

Operator's Manual

## Introduction

This rotary-blade, walk-behind lawn mower is intended to be used by residential homeowners. It is designed primarily for cutting grass on well-maintained lawns on residential properties. It is not designed for cutting brush or for agricultural uses.

Read this information carefully to learn how to operate and maintain your product properly and to avoid injury and product damage. You are responsible for operating the product properly and safely.

You may contact Toro directly at [www.Toro.com](http://www.Toro.com) for product and accessory information, help finding a dealer, or to register your product.

Whenever you need service, genuine Toro parts, or additional information, contact an Authorized Service Dealer or Toro Customer Service and have the model and serial numbers of your product ready. Figure 1 identifies the location of the model and serial numbers on the product.

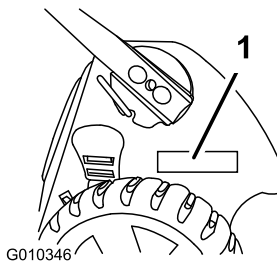

Figure 1

1. Model and serial number plate

Write the product model and serial numbers in the space below:

Model No. _____
Serial No. _____

This manual identifies potential hazards and has safety messages identified by the safety alert symbol (Figure 2), which signals a hazard that may cause serious

injury or death if you do not follow the recommended precautions.



Figure 2

1. Safety alert symbol

This manual uses 2 words to highlight information. **Important** calls attention to special mechanical information and **Note** emphasizes general information worthy of special attention.

### WARNING

#### CALIFORNIA Proposition 65 Warning

The engine exhaust from this product contains chemicals known to the State of California to cause cancer, birth defects, or other reproductive harm.

**Important:** This engine is not equipped with a spark arrester muffler. It is a violation of California Public Resource Code Section 4442 to use or operate the engine on any forest-covered, brush-covered, or grass-covered land. Other states or federal areas may have similar laws.

This spark ignition system complies with Canadian ICES-002.

The enclosed *Engine Owner's Manual* is supplied for information regarding the US Environmental Protection Agency (EPA) and the California Emission Control Regulation of emission systems, maintenance, and warranty. Replacements may be ordered through the engine manufacturer.

For models with stated engine horsepower, the gross horsepower of the engine was laboratory rated by the engine manufacturer in accordance with SAE J1940. As configured to meet safety, emission, and operating requirements, the actual engine horsepower on this class of lawn mower will be significantly lower.

# Safety

**Improperly using or maintaining this mower can result in injury. To reduce the potential for injury, comply with these safety instructions.**

Toro designed and tested this mower for reasonably safe service; however, failure to comply with the following instructions may result in personal injury.

**To ensure maximum safety, best performance, and to gain knowledge of the product, it is essential that you and any other operator of the mower read and understand the contents of this manual before the engine is ever started. Pay particular attention to the safety alert symbol (Figure 2) which means Caution, Warning, or Danger—“personal safety instruction.” Read and understand the instruction because it has to do with safety. Failure to comply with the instruction may result in personal injury.**

## General Lawn Mower Safety

The following instructions have been adapted from the ISO standard 5395.

This cutting machine is capable of amputating hands and feet and throwing objects. Failure to observe the following safety instructions could result in serious injury or death.

### Training

- Read the instructions carefully. Be familiar with the controls and the proper use of the equipment.
- Never allow children or people unfamiliar with these instructions to use the mower. Local regulations can restrict the age of the operator.
- Keep in mind that the operator or user is responsible for accidents or hazards occurring to other people or their property.
- Understand explanations for all pictograms used on the mower or in the instructions.

### Gasoline

**WARNING**-Gasoline is highly flammable. Take the following precautions.

- Store fuel in containers specifically designed for this purpose.
- Refuel outdoors only and do not smoke while refueling.
- Add fuel before starting the engine. Never remove the cap of the fuel tank or add gasoline while the engine is running or when the engine is hot.

- If gasoline is spilled, do not attempt to start the engine but move the mower away from the area of spillage and avoid creating any source of ignition until gasoline vapors have dissipated.
- Replace all fuel tank and container caps securely.

### Preparation

- While mowing, always wear substantial footwear and long trousers. Do not operate the equipment when barefoot or wearing open sandals.
- Thoroughly inspect the area where the equipment is to be used and remove all stones, sticks, wires, bones and other foreign objects.
- Before using, always visually inspect to see that guards, and safety devices, such as deflectors and/or grass catchers, are in place and working correctly.
- Before using, always visually inspect to see that the blades, blade bolts and cutter assembly are not worn or damaged. Replace worn or damaged blades and bolts in sets to preserve balance.

### Starting

- Do not tilt mower when starting the engine unless the mower has to be tilted for starting. In this case, do not tilt it more than absolutely necessary and lift only the part, which is away from the operator.
- Start the engine carefully according to instructions and with feet well away from the blade(s) and not in front of the discharge chute.

### Operation

- Never mow while people, especially children, or pets are nearby.
- Mow only in daylight or in good artificial light.
- Stay alert for holes in the terrain and other hidden hazards.
- Do not put hands or feet near or under rotating parts. Keep clear of the discharge opening at all times.
- Never pick up or carry a lawn mower while the engine is running.
- Use extreme caution when reversing or pulling a pedestrian controlled lawn mower towards you.
- Walk, never run.
- Slopes:
  - Do not mow excessively steep slopes.
  - Exercise extreme caution when on slopes.
  - Mow across the face of slopes, never up and down and exercise extreme caution when changing direction on slopes.

- Always be sure of your footing on slopes.
- Reduce speed on slopes and in sharp turns to prevent overturning or loss of control.
- Stop the blade if the lawn mower has to be tilted for transportation when crossing surfaces other than grass and when transporting the lawn mower to and from the area to be mowed.
- Do not operate the engine in a confined space where dangerous carbon monoxide fumes can collect.
- Stop the engine
  - whenever you leave the lawn mower.
  - before refueling.
  - before removing the grass catcher.
  - before making height adjustment unless adjustment can be made from the operator's position.
- Stop the engine and disconnect the spark-plug wire.
  - before clearing blockages or unclogging chute.
  - before checking, cleaning or working on the lawn mower.
  - after striking a foreign object, inspect the lawn mower for damage and make repairs before restarting and operating the lawn mower.
  - if lawn mower starts to vibrate abnormally (check immediately).
- Lightning can cause severe injury or death. If you see lightning or hear thunder in the area, do not operate the machine; seek shelter.
- Watch out for traffic when crossing or near roadways.
- Replace worn or damaged parts for safety.
- Replace faulty silencers.
- If the fuel tank has to be drained, do this out-doors.
- Do not change the engine governor settings or overspeed the engine. Operating an engine at excessive speed can increase the hazard of personal injury.
- On multibladed lawn mowers, take care as rotating one blade may cause others to rotate.
- Be careful during adjustment of the lawn mower to prevent entrapment of the fingers between moving blades and fixed parts of the lawn mower.
- **To ensure the best performance and safety, purchase only genuine Toro replacement parts and accessories. Do not use *will fit* parts and accessories; they may cause a safety hazard.**

## Maintenance and Storage

- Keep all nuts, bolts and screws tight to be sure the equipment is in safe working condition.
- Do not use pressure cleaning equipment on machine.
- Never store the equipment with gasoline in the tank and inside a building where fumes can reach an open flame or spark.
- Allow the engine to cool before storing in any enclosure.
- To reduce the fire hazard, keep the engine, silencer, battery compartment and gasoline storage area free of grass, leaves, or excessive grease.
- Check grass catcher components and the discharge guard frequently and replace with manufacturer's recommended parts, when necessary.

## Sound Pressure

This unit has a sound pressure level at the operator's ear of 89 dBA, which includes an Uncertainty Value (K) of 1 dBA. The sound pressure level was determined according to the procedures outlined in EN 836.

## Sound Power

This unit has a guaranteed sound power level of 98 dBA, which includes an Uncertainty Value (K) of 1 dBA. The sound power level was determined according to the procedures outlined in ISO 11094.

## Hand-Arm Vibration

Measured vibration level for the left hand = 3.8 m/s<sup>2</sup>

Measured vibration level for the right hand = 4.1 m/s<sup>2</sup>

Uncertainty Value (K) = 2.1 m/s<sup>2</sup>

The measured values were determined according to the procedures outlined in EN 836.

# Safety and Instructional Decals

**Important:** Safety and instruction decals are located near areas of potential danger. Replace damaged decals.

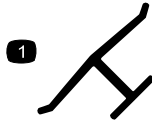

**Manufacturer's Mark**

1. Indicates the blade is identified as a part from the original machine manufacturer.

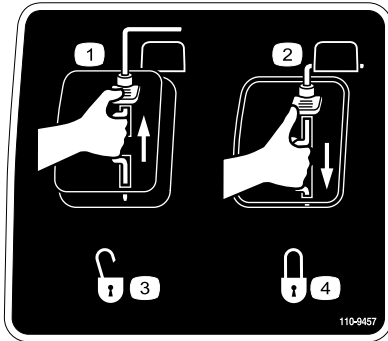

**110-9457**

- |                      |             |
|----------------------|-------------|
| 1. Engine switch Off | 3. Unlocked |
| 2. Engine switch On  | 4. Locked   |

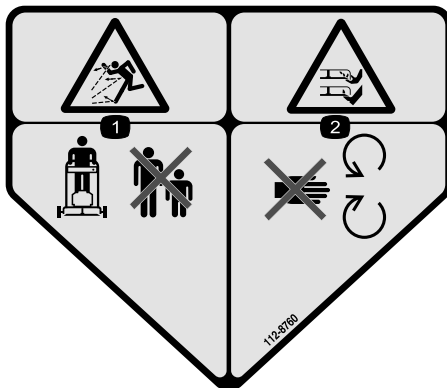

**112-8760**

1. Thrown object hazard—stay a safe distance from the machine.
2. Cutting/dismemberment of hand or foot—stay away from moving parts.

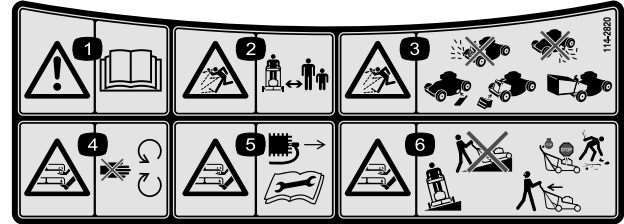

**114-2820**

- |                                                                                                                                                                                    |                                                                                                                                                                                                                             |
|------------------------------------------------------------------------------------------------------------------------------------------------------------------------------------|-----------------------------------------------------------------------------------------------------------------------------------------------------------------------------------------------------------------------------|
| 1. Warning—read the <i>Operator's Manual</i> .                                                                                                                                     | 4. Cutting/dismemberment hazard of hand or foot, mower blade—stay away from moving parts.                                                                                                                                   |
| 2. Thrown object hazard—keep bystanders a safe distance from the machine.                                                                                                          | 5. Cutting/dismemberment hazard of hand or foot, mower blade—remove the ignition key and read the instructions before servicing or performing maintenance.                                                                  |
| 3. Thrown object hazard—do not operate the mower without the rear discharge plug or bag in place; do not operate the mower without the side discharge cover or deflector in place. | 6. Cutting/dismemberment hazard of hand or foot, mower blade—do not operate up and down slopes; operate side to side on slopes; stop the engine before leaving the operating position; and look behind you when backing up. |

# Setup

## 1

### Unfolding the Handle

#### No Parts Required

#### Procedure

1. Move the handle rearward and hold the upper handle in place (Figure 3).

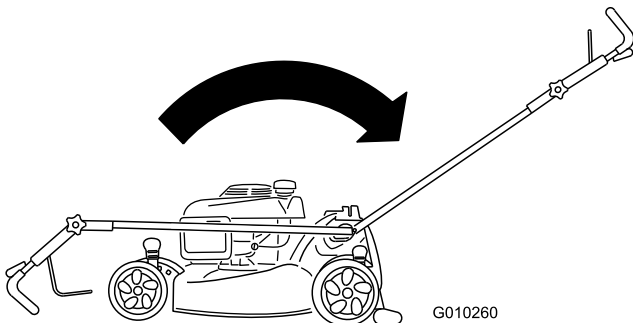

Figure 3

**Note:** The handle will click into position.

2. Tighten the upper handle knob as tight as you can (Figure 4).

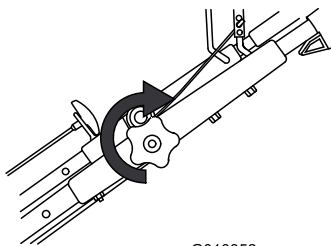

Figure 4

## 2

### Filling the Engine with Oil

#### Parts needed for this procedure:

0.58 quart (0.55 l)	SAE 30 detergent oil with an API service classification of SH, SJ, SL, or higher (not supplied with the mower).
---------------------	-----------------------------------------------------------------------------------------------------------------

#### Procedure

**Important:** Your mower *does not* come with oil in the engine.

1. Remove the dipstick (Figure 5).

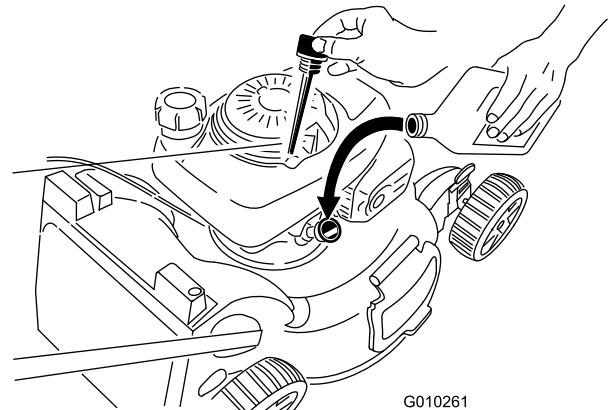
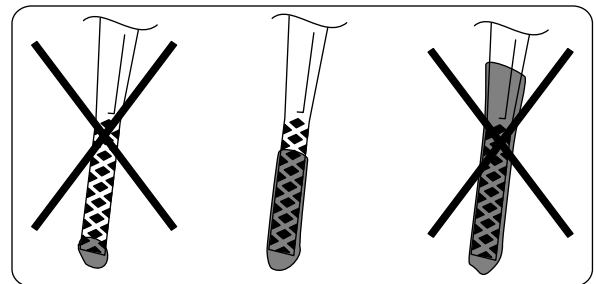

Figure 5

2. **Slowly** pour oil into the oil fill tube, periodically checking the level with the dipstick, until the dipstick indicates that the engine is full as illustrated in Figure 5. **Do not overfill.** (Max. fill: 0.58 quart (0.55 l), **type: SAE 30 detergent oil** with an API service classification of SH, SJ, SL, or higher.)

**Note:** If you overfill the engine, pour some oil out of it as directed in Changing the Engine Oil.

3. Install the dipstick securely.

**Important:** *Change the engine oil after the first 5 operating hours; change it yearly thereafter. Refer to Changing the Engine Oil.*

# 3

## Install the Mulch Plug or Grass Bag

### No Parts Required

### Procedure

You must correctly install the mulch plug (for mulching or side-discharging) or grass bag (for bagging) or **the engine will not start.**

The mower has a safety switch, located at the bottom of a channel on the top, right rear of the mower, that prevents the mower from operating without a mulch plug or grass bag. This prevents the mower from throwing debris at the operator through the rear chute.

For the switch to detect the presence of the mulch plug, the top of the mulch plug lever must **lie fully** in the **bottom of the channel** (Figure 6).

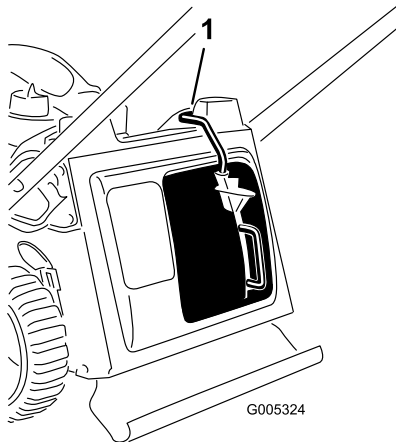

Figure 6

1. Top of mulch plug lever in switch channel

1. Insert the mulch plug into the mower, if it isn't already installed (Figure 7).

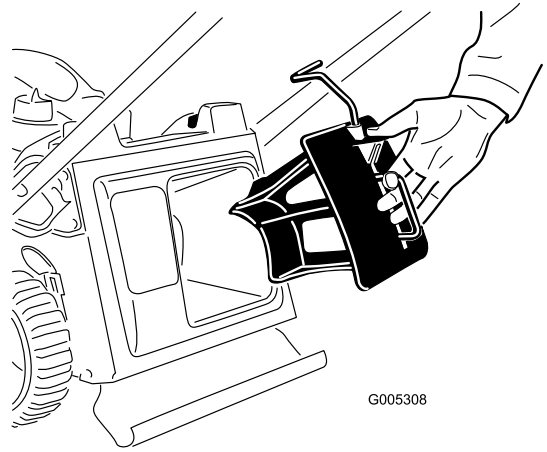

Figure 7

2. Squeeze the button on the lever with your thumb and fully insert the mulch plug into the opening (Figure 8).

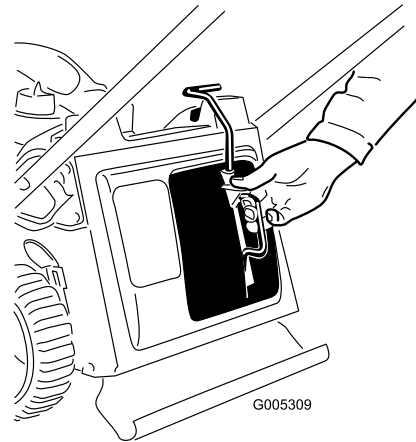

Figure 8

3. Release the button on the lever and ensure that the top of the lever is lies fully in the switch channel (Figure 9). **If the top of the lever is not in the switch channel, your mower will not start!**

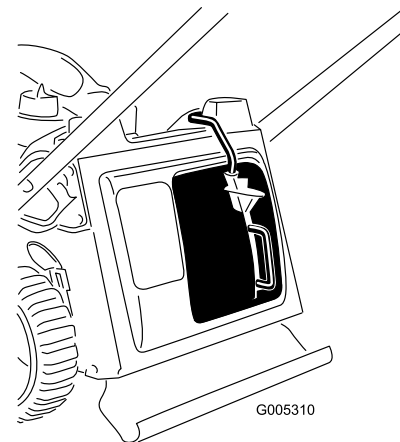
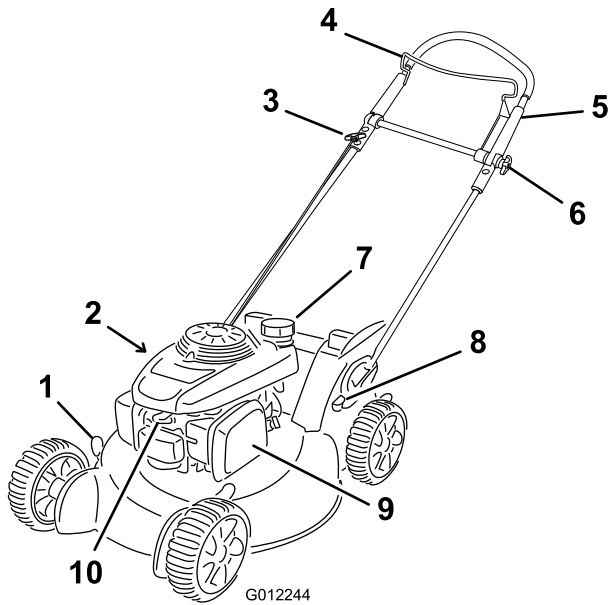

Figure 9

**Note:** If the lever does not latch properly, disconnect the wire from the spark plug and check for and remove any debris buildup in the tunnel.

## Product Overview



G012244

**Figure 10**

- |                                  |                      |
|----------------------------------|----------------------|
| 1. Cutting height lever          | 6. Upper handle knob |
| 2. Oil fill/Dipstick (not shown) | 7. Fuel tank cap     |
| 3. Recoil start handle           | 8. Foot pedal        |
| 4. Blade control bar             | 9. Air filter        |
| 5. Upper handle                  | 10. Spark plug       |

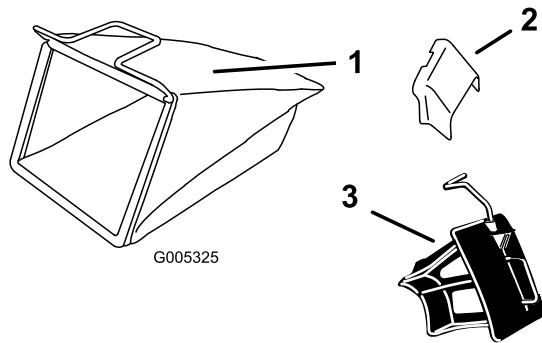

G005325

**Figure 11**

- |                         |                           |
|-------------------------|---------------------------|
| 1. Grass bag            | 3. Mulch plug (installed) |
| 2. Side discharge chute |                           |

## Specifications

Model	Weight	Length	Width	Height
20899	80 lb (36 kg)	63 in (159 cm)	22 in (57 cm)	43 in (109 cm)

## Operation

### Filling the Fuel Tank

#### **⚠ DANGER**

Gasoline is extremely flammable and explosive. A fire or explosion from gasoline can burn you and others.

- To prevent a static charge from igniting the gasoline, place the container and/or mower directly on the ground before filling, not in a vehicle or on an object.
- Fill the tank outdoors when the engine is cold. Wipe up spills.
- Do not handle gasoline when smoking or around an open flame or sparks.
- Store gasoline in an approved fuel container, out of the reach of children.

Fill the fuel tank with fresh unleaded regular gasoline from a major name-brand service station (Figure 12).

**Important:** To reduce starting problems, add fuel stabilizer to the fuel all season, mixing it with gasoline less than 30 days old.

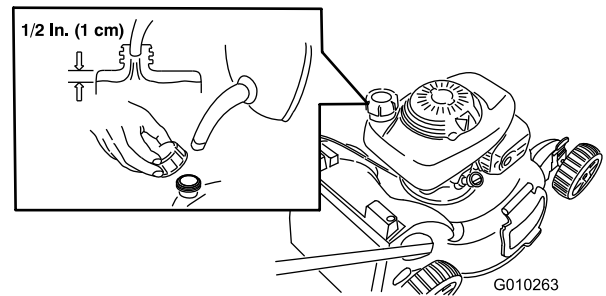

G010263

**Figure 12**



# Checking the Engine Oil Level

**Service Interval:** Before each use or daily

1. Remove the dipstick, wipe it clean, and insert it into the oil filler neck, **but do not screw it in** (Figure 13).

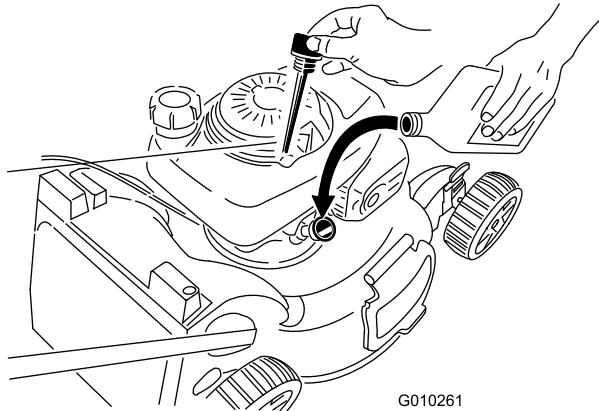
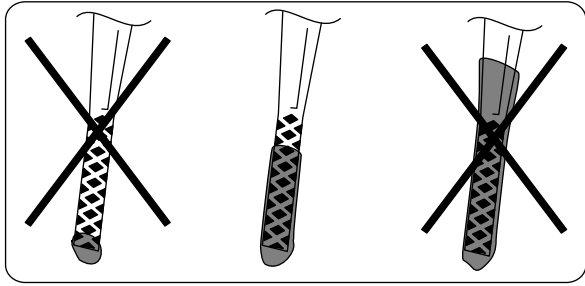

Figure 13

2. Remove the dipstick and check the oil level (Figure 13).

If there is no oil on the dipstick, **slowly** pour oil into the oil fill tube, periodically checking the level with the dipstick, until the dipstick indicates that the engine is full as illustrated in Figure 13. **Do not overfill.** (Max. fill: 0.58 quart (0.55 l), type: SAE 30 detergent oil with an API service classification of SH, SJ, SL, or higher.)

**Note:** If you overfill the engine, pour some oil out of it as directed in Changing the Engine Oil.

3. Install the dipstick securely.

# Adjusting the Cutting Height

## ⚠ WARNING

Adjusting the cutting height may bring you into contact with the moving blade, causing serious injury.

- Stop the engine and wait for all moving parts to stop.
- Do not put your fingers under the housing when adjusting the cutting height.

Adjust the cutting height as desired. Set all four wheels to the same height.

**Note:** To raise the mower, move all 4 cutting height levers forward; to lower the mower, move them rearward.

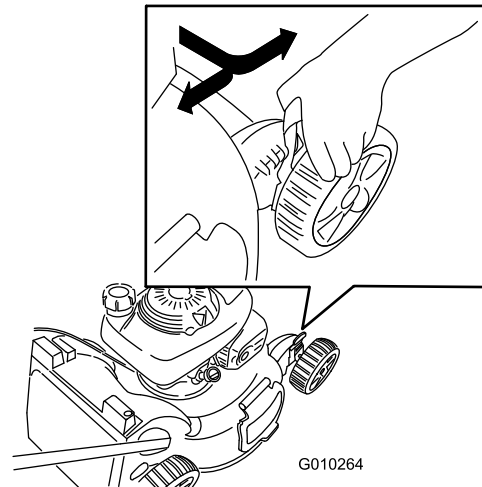

Figure 14

# Adjusting the Upper Handle Height

You may raise or lower the upper handle to a position comfortable for you.

**Note:** You cannot raise the upper handle higher than the angle of the lower handle.

1. Loosen the upper handle knob (Figure 15).

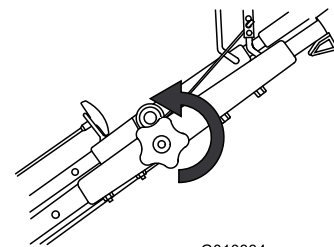
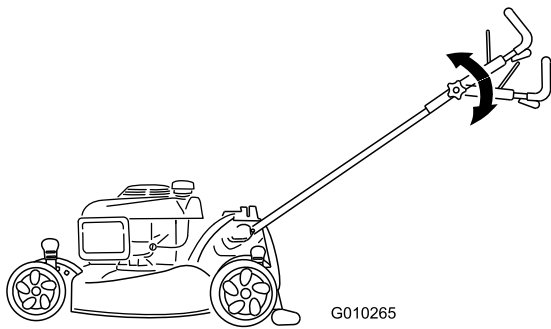
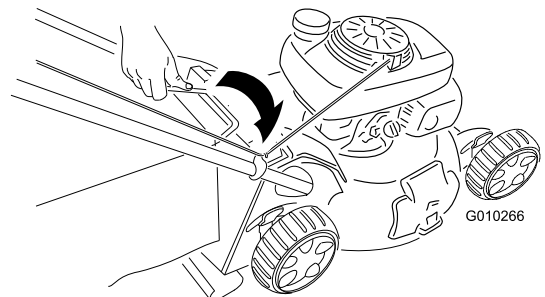

Figure 15

2. Move the upper handle to the desired position (Figure 16).

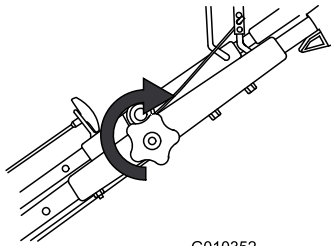

**Figure 16**



**Figure 19**

3. Tighten the upper handle knob as tight as you can (Figure 17).



**Figure 17**

2. Turn the fuel valve lever to the On position (Figure 20).

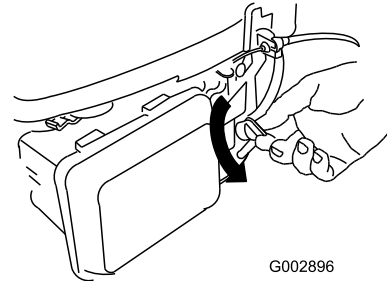
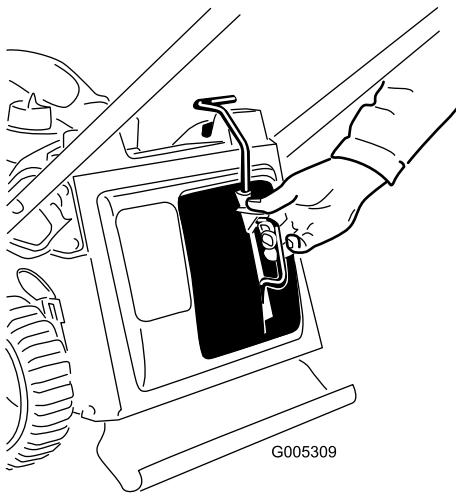

**Figure 20**

## Starting the Engine

**Important:** The mower has a safety switch that prevents you from starting the mower unless you first install the mulch plug or the grass bag securely on the mower.

1. Install the mulch plug (Figure 18) or the grass bag (Figure 19) on the mower.



**Figure 18**

3. Hold the blade control bar against the handle and pull the recoil starter (Figure 21).

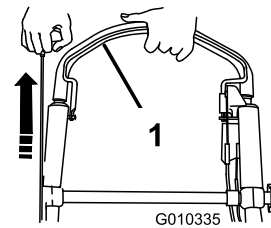

**Figure 21**

1. Blade control bar

**Note:** If the mower does not start, contact an Authorized Service Dealer.

## Using the Self-propel Drive

To operate the self-propel drive, simply walk with your hands on the upper handle and your elbows at your sides, and the mower will automatically keep pace with you (Figure 22).

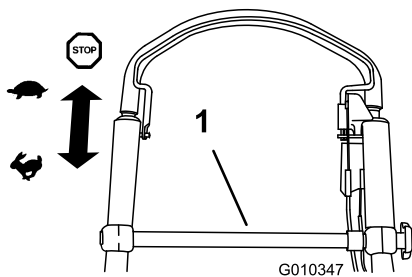

Figure 22

1. Nudge here

**Note:** If, when backing up after self-propelling, the mower does not roll backward freely, nudge the mower forward about an inch or two without engaging the self-propel drive (Figure 22), then pull the mower backward.

## Stopping the Engine

**Service Interval:** Before each use or daily

To stop the engine, release the blade control bar (Figure 23).

**Important:** When you release the blade control bar, both the engine and blade should stop within 3 seconds. If they do not stop properly, stop using your mower immediately and contact an Authorized Service Dealer.

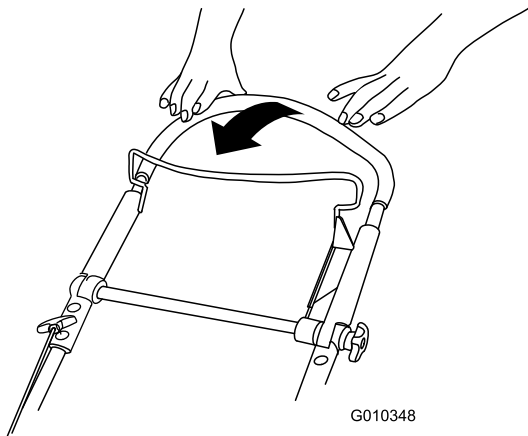

Figure 23

## Mulching the Clippings

Your mower comes from the factory ready to mulch the grass and leaf clippings back into the lawn.

If the grass bag is on the mower, remove it (refer to Removing the Grass Bag) before mulching the clippings. If the side discharge chute is on the mower, remove it and lock the side discharge door (refer to Removing the Side Discharge Chute) before mulching the clippings.

**Important:** The mower has a safety switch that prevents you from starting the mower unless you first install the mulch plug securely on the mower (Figure 24).

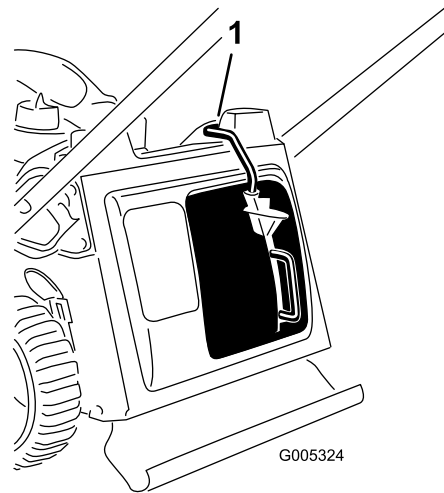

Figure 24

1. Top of mulch plug lever in switch channel

## Bagging the Clippings

Use the grass bag when you want to collect grass and leaf clippings from the lawn.

If the side discharge chute is on the mower, remove it and lock the side discharge door (refer to Removing the Side Discharge Chute) before bagging the clippings.

### ⚠ WARNING

A worn grass bag could allow small stones and other similar debris to be thrown in the operator's or bystander's direction and result in serious personal injury or death to the operator or bystanders.

Check the grass bag frequently. If it is damaged, install a new Toro replacement bag.

### ⚠ WARNING

The blade is sharp; contacting the blade can result in serious personal injury.

Stop the engine and wait for all moving parts to stop before leaving the operating position.

## Installing the Grass Bag

1. Remove the mulch plug (Figure 25).

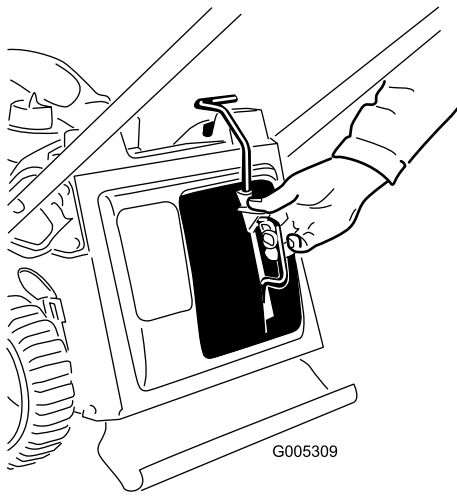

Figure 25

## Removing the Grass Bag

1. Route the starter rope around the lower rope guide (Figure 28).

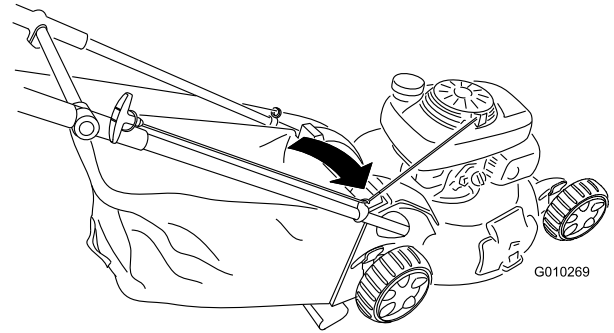

Figure 28

2. Route the starter rope around the lower rope guide (Figure 26).

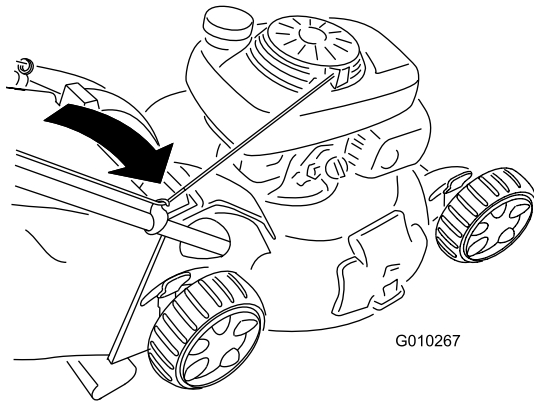

Figure 26

2. Lift the grass bag handle out from the grooves at the top of the mower and remove the bag from the mower (Figure 29).

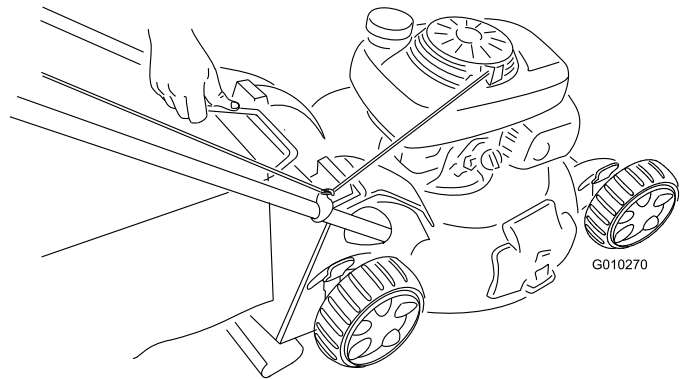

Figure 29

**Note:** The lower rope guide releases the starter rope when you pull the recoil start handle.

3. Insert the grass bag handle into the grooves at the top of the mower (Figure 27).

**Important:** The mower has a safety switch that prevents you from starting the mower unless you first install the grass bag securely on the mower.

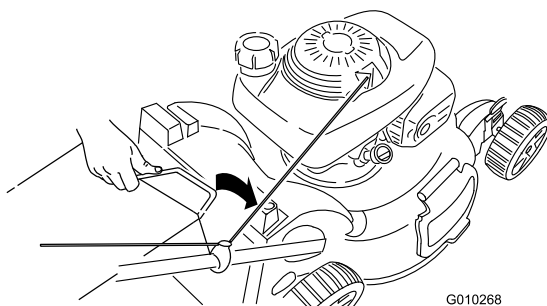

Figure 27

3. Insert the mulch plug (Figure 30).

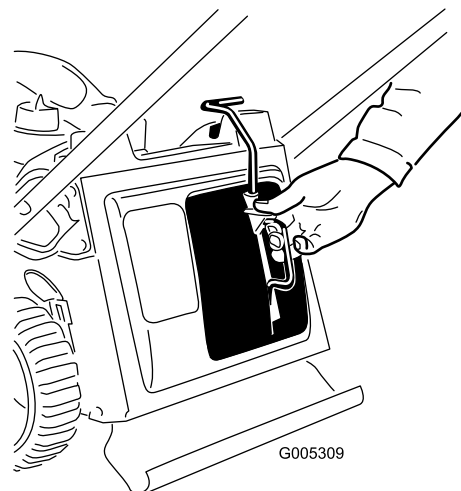

Figure 30

## Side-discharging the Clippings

Use the side discharge for cutting very tall grass.

If the bag is on the mower, remove it and insert the mulch plug (refer to Removing the Grass Bag) before side-discharging the clippings.

**Important:** The mower has a safety switch that prevents you from starting the mower unless you first install the mulch plug securely on the mower (refer to Mulching the Clippings).

## Installing the Side Discharge Chute

1. Unlock the side discharge door (Figure 31).

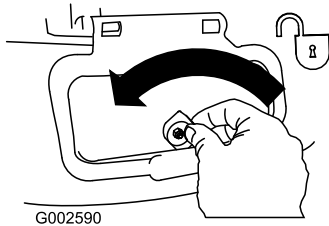

Figure 31

2. Lift open the side discharge door (Figure 32).

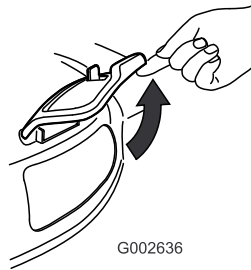

Figure 32

3. Install the side discharge chute and close the door onto the chute (Figure 33).

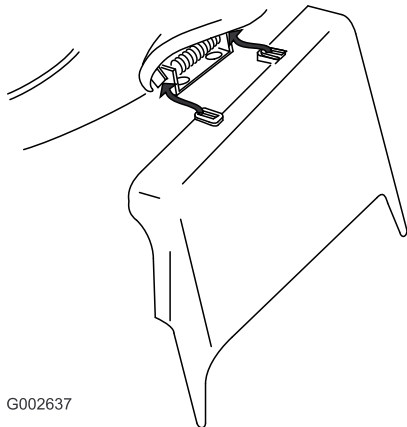

Figure 33

## Removing the Side Discharge Chute

To remove the side discharge chute, reverse the steps above.

**Important:** Lock the side discharge door after you close it (Figure 34).

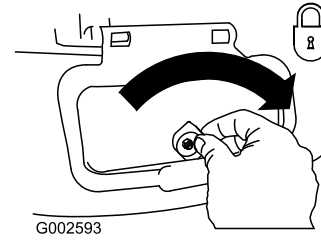

Figure 34

## Operating Tips

### General Mowing Tips

- Clear the area of sticks, stones, wire, branches, and other debris that the blade could hit.
- Avoid striking solid objects with the blade. Never deliberately mow over any object.
- If the mower strikes an object or starts to vibrate, immediately stop the engine, disconnect the wire from the spark plug, and examine the mower for damage.
- For best performance, install a new blade before the cutting season begins.
- Replace the blade when necessary with a Toro replacement blade.

### Cutting Grass

- Cut only about a third of the grass blade at a time. Do not cut below the 2 inch (51 mm) setting unless the grass is sparse or it is late fall when grass growth begins to slow down. Refer to Adjusting the Cutting Height.
- When cutting grass over 6 inches (15 cm) tall, mow at the highest cutting height setting and walk slower; then mow again at a lower setting for the best lawn appearance. If the grass is too long, the mower may plug and cause the engine to stall.
- Mow only dry grass or leaves. Wet grass and leaves tend to clump on the yard and can cause the mower to plug or the engine to stall.

## ⚠ WARNING

Wet grass or leaves can cause serious injury if you slip and contact the blade. Mow only in dry conditions.

- Alternate the mowing direction. This helps disperse the clippings over the lawn for even fertilization.
- If the finished lawn appearance is unsatisfactory, try one or more of the following:
  - Replace the blade or have it sharpened.
  - Walk at a slower pace while mowing.
  - Raise the cutting height on your mower.
  - Cut the grass more frequently.
  - Overlap cutting swaths instead of cutting a full swath with each pass.

- Set the cutting height on the front wheels one notch lower than the rear wheels. For example, set the front wheels at 2 inches (51 mm) and the rear wheels at 2-1/2 inches (64 mm).

## Cutting Leaves

- After cutting the lawn, ensure that half of the lawn shows through the cut leaf cover. You may need to make more than one pass over the leaves.
- If there are more than 5 inches (13 cm) of leaves on the lawn, set the front cutting height one or two notches higher than the rear cutting height.
- Slow down your mowing speed if the mower does not cut the leaves finely enough.

# Maintenance

**Note:** Determine the left and right sides of the machine from the normal operating position.

## Recommended Maintenance Schedule(s)

Maintenance Service Interval	Maintenance Procedure
After the first 5 hours	<ul style="list-style-type: none"><li>• Change the engine oil.</li></ul>
Before each use or daily	<ul style="list-style-type: none"><li>• Check the engine oil level.</li><li>• Ensure that the engine stops within 3 seconds after releasing the blade control bar.</li><li>• Check the air cleaner for dirt and /or damage and clean or replace it if necessary.</li><li>• Clean grass clippings and dirt from under the mower.</li></ul>
Before storage	<ul style="list-style-type: none"><li>• Empty the fuel tank before repairs as directed and before annual storage.</li></ul>
Yearly	<ul style="list-style-type: none"><li>• Clean the air filter (more frequently in dusty operating conditions).</li><li>• Change the engine oil.</li><li>• Lubricate the upper handle.</li><li>• Replace the blade or have it sharpened (more frequently if the edge dulls quickly).</li><li>• Refer to your Engine Operator's Manual for any additional yearly maintenance procedures.</li></ul>

**Important:** Refer to your *Engine Operator's Manual* for additional maintenance procedures.

## Preparing for Maintenance

1. Stop the engine and wait for all moving parts to stop.
2. Disconnect the spark plug wire from the spark plug (Figure 35) before performing any maintenance procedure.

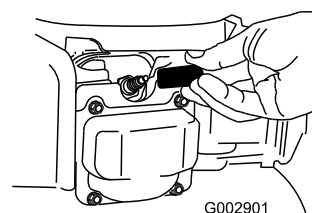

**Figure 35**

3. After performing the maintenance procedure(s), connect the spark plug wire to the spark plug.

**Important:** Before tipping the mower to change the oil or replace the blade, allow the fuel tank to run dry through normal usage. If you must tip the mower prior to running out of fuel, use a hand fuel pump to remove the fuel. Always tip the mower onto its side with the air filter up.

**⚠ WARNING**

Tipping the mower may cause the fuel to leak. Gasoline is flammable, explosive and can cause personal injury.

Run the engine dry or remove the gasoline with a hand pump; never siphon.

## Servicing the Air Cleaner

**Service Interval:** Before each use or daily  
Yearly

1. Press down on the latch tabs on top of the air cleaner cover (Figure 36).

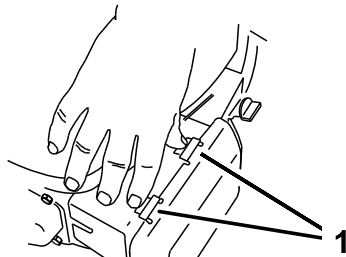

G002902

**Figure 36**

1. Latch tabs

- 
2. Open the cover.
  3. Remove the air filter (Figure 37).

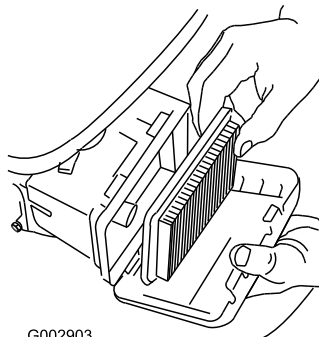

G002903

**Figure 37**

- 
4. If the air filter is damaged or is wet with oil or fuel, replace it.
  5. If the air filter is dirty, tap it on a hard surface several times or blow compressed air less than 30 psi (207

kPa) through the side of the filter that faces the engine.

**Note:** Do not brush the dirt off the filter; brushing forces dirt into the fibers.

6. Remove dirt from the air cleaner body and cover using a moist rag. **Do not wipe dirt into the air duct.**
7. Install the filter into the air cleaner.
8. Close the cover.

## Changing the Engine Oil

**Service Interval:** After the first 5 hours  
Yearly

**Change the engine oil after the first 5 operating hours;** change it yearly thereafter.

Run the engine a few minutes before changing the oil to warm it. Warm oil flows better and carries more contaminants.

1. Perform the pre-maintenance procedures; refer to Preparing for Maintenance.
2. Remove the dipstick (Figure 38).

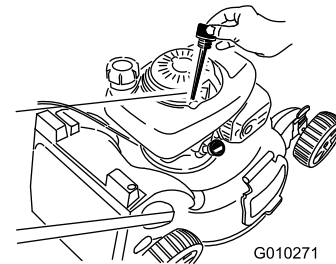

G010271

**Figure 38**

- 
3. Tip the mower onto its side, with the air filter up, to drain the used oil out through the oil fill tube (Figure 39).

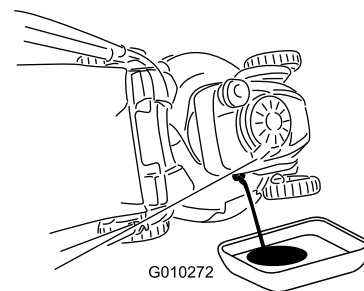

G010272

**Figure 39**

- 
4. **Slowly** pour oil into the oil fill tube, periodically checking the level with the dipstick, until the dipstick

indicates that the engine is full as illustrated in Figure 40. **Do not overfill.** (Max. fill: 0.58 quart (0.55 l), type: SAE 30 detergent oil with an API service classification of SH, SJ, SL, or higher.)

**Note:** If you overfill the engine, pour some oil out of it.

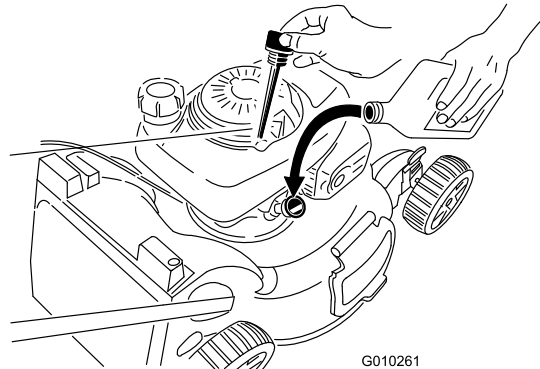
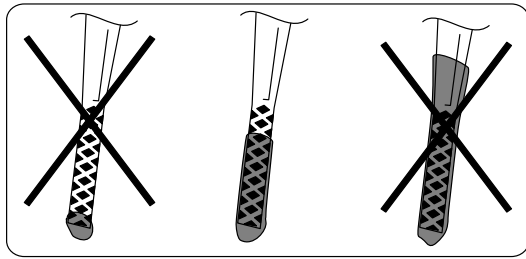

**Figure 40**

5. Install the dipstick securely.
6. Dispose of the used oil properly at a local recycling center.

## Lubricating the Upper Handle

**Service Interval:** Yearly

Lubricate the left and right sides of the upper handle with a low-viscosity silicone spray lubricant yearly or as needed.

1. Spray the outer plastic end of the inner handle (Figure 41).

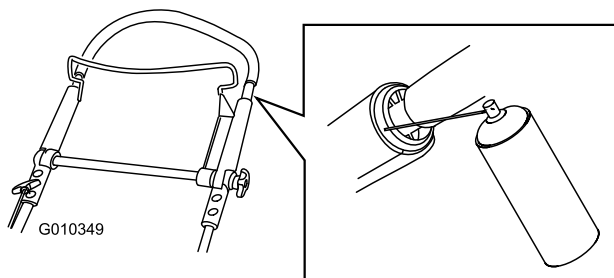

**Figure 41**

**Note:** Use the straw that comes with the spray can to direct the spray.

2. Push the upper handle fully down and spray the inner plastic surface of the outer handle (Figure 42).

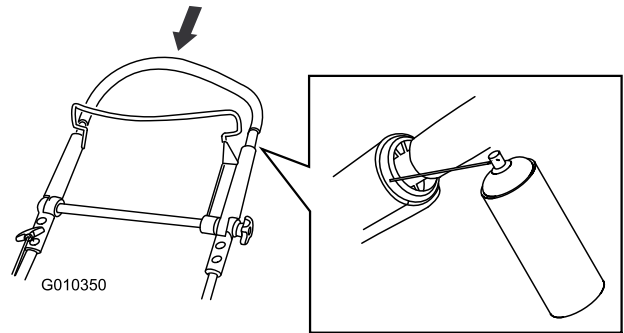
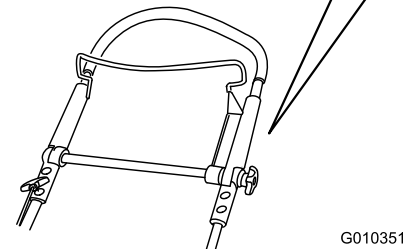
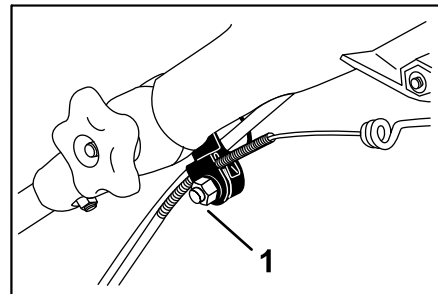

**Figure 42**

## Adjusting the Self-propel Drive

If your mower does not self-propel properly, adjust the self-propel drive cable.

1. Loosen the nut on the cable mount (Figure 43).

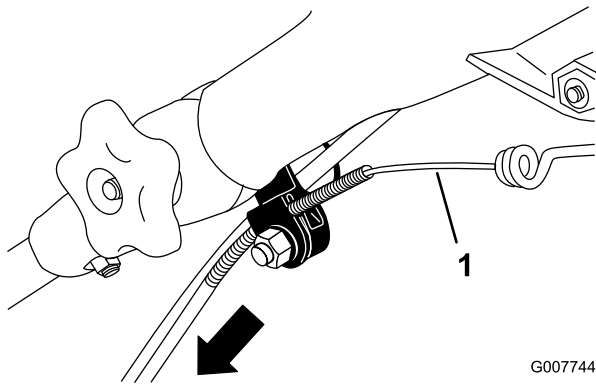

**Figure 43**

1. Cable mount
2. Pull the upper handle back fully rearward.
 

**Note:** If the handle does not move smoothly, refer to Lubricating the Upper Handle.
3. Pull the cable jacket downward until you remove the slack in the exposed cable (Figure 44).



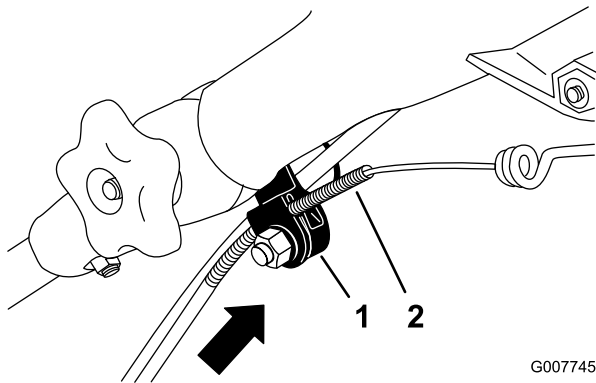

**Figure 44**

1. Exposed cable

4. Push the cable jacket upward 1/8 inch (3 mm).

**Note:** You can place a ruler against the upper side of the black cable mount and measure how far the upper end of the cable jacket moves (Figure 45).



**Figure 45**

1. Cable mount
2. Cable jacket

**Note:** Moving the cable jacket upward decreases the ground speed; moving the jacket downward increases the ground speed.

5. Tighten the nut firmly.
6. Start the mower and check the adjustment.

**Note:** If the self-propel drive is not properly adjusted, repeat this procedure.

## Replacing the Blade

**Service Interval:** Yearly

**Important:** *You will need a torque wrench to install the blade properly. If you do not have a torque wrench or are uncomfortable performing this procedure, contact an Authorized Service Dealer.*

Examine the blade whenever you run out of gasoline. If the blade is damaged or cracked, replace it immediately.

If the blade edge is dull or nicked, have it sharpened or replace it.

### **▲ WARNING**

**The blade is sharp; contacting the blade can result in serious personal injury.**

**Wear gloves when servicing the blade.**

1. Disconnect the spark plug wire from the spark plug. Refer to Preparing for Maintenance.
2. Tip the mower onto its side, with the air filter up.
3. Use a block of wood to hold the blade steady (Figure 46).

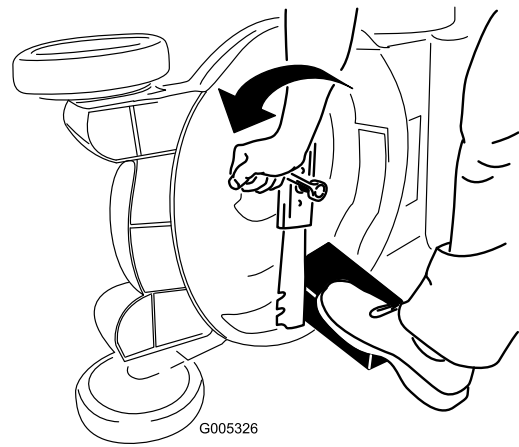

**Figure 46**

4. Remove the blade, saving all mounting hardware (Figure 46).
5. Install the new blade and all mounting hardware (Figure 47).

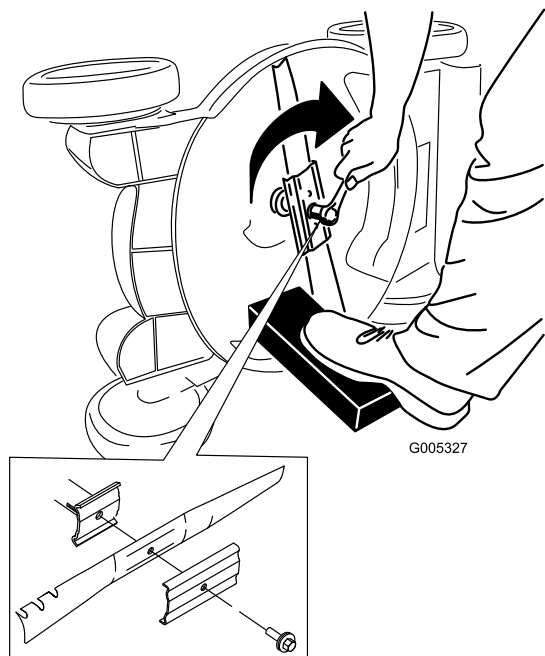

Figure 47

**Important:** Position the curved ends of the blade to point toward the mower housing.

- Use a torque wrench to tighten the blade bolt to 60 ft-lb (82 N-m).

**Important:** A bolt torqued to 60 ft-lb (82 N-m) is very tight. While holding the blade with a block of wood, put your weight behind the ratchet or wrench and tighten the bolt securely. This bolt is very difficult to overtighten.

## Cleaning the Mower

**Service Interval:** Before each use or daily

### ⚠ WARNING

The mower may dislodge material from under the mower housing.

- Wear eye protection.
  - Stay in the operating position (behind the handle).
  - Do not allow bystanders in the area.
- With the engine running on a flat paved surface, spray a stream of water in front of the **right** rear wheel (Figure 48).  
The water will splash into the path of the blade, cleaning out the clippings.

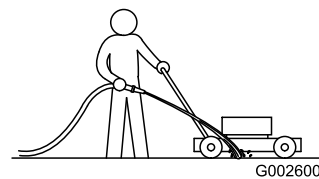

Figure 48

- When no more clippings come out, stop the water and move the mower to a dry area.
- Run the engine for a few minutes to dry the housing to prevent it from rusting.

## Storage

Store the mower in a cool, clean, dry place.

## Preparing the Mower for Storage

### ⚠ WARNING

Gasoline vapors can explode.

- Do not store gasoline more than 30 days.
  - Do not store the mower in an enclosure near an open flame.
  - Allow the engine to cool before storing it.
- On the last refueling of the year, add fuel stabilizer to the fuel as directed by the engine manufacturer.
  - Run the mower until the engine stops from running out of fuel.
  - Prime the engine and start it again.
  - Allow the engine to run until it stops. When you can no longer start the engine, it is sufficiently dry.
  - Disconnect the wire from the spark plug and connect the wire onto the retaining post.
  - Remove the spark plug, add 1 oz. (30 ml) of oil through the spark plug hole, and pull the starter rope **slowly** several times to distribute oil throughout the cylinder to prevent cylinder corrosion during the off-season.
  - Install the spark plug and tighten it with a torque wrench to 15 ft-lb (20 N-m).
  - Tighten all nuts, bolts, and screws.

## Folding the Handle

### Upright Position

- Step on the foot pedal and hold it down (Figure 49).

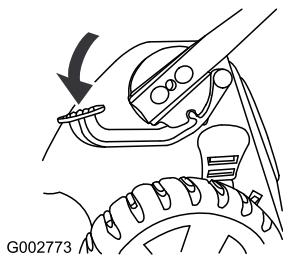

**Figure 49**

- 
2. Move the handle to the upright position (Figure 50).

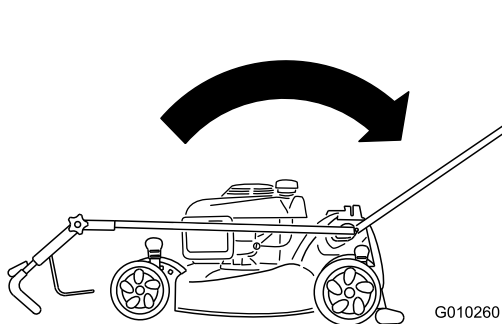
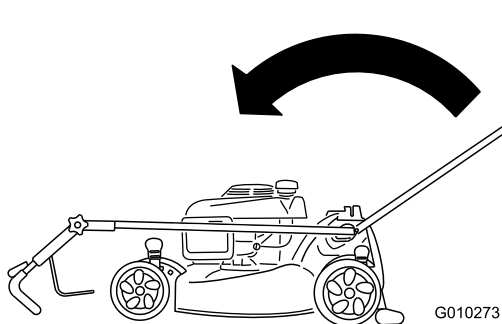

**Figure 50**

---

## Forward Position

1. With the handle in the upright position, step on the foot pedal and hold it down.
2. Move the handle all the way forward and loosen the upper handle knob (Figure 51).



**Figure 51**

- 
3. To unfold the handle, refer to Unfolding the Handle.

---

## Removing the Mower from Storage

Connect the wire to the spark plug.



**The Toro Total Coverage Guarantee**  
 A 5-Year Full Warranty (45 Day Limited Warranty for Commercial Use)  
**The Toro GTS Starting Guarantee**  
 A 5-Year Full Warranty (Not Applicable for Commercial Use)

Super Recycler®  
 Super Bagger  
 Walk Power Mowers

**Conditions and Products Covered**

The Toro Company and its affiliate, Toro Warranty Company, pursuant to an agreement between them, jointly promise to repair the Toro Products listed below if used for residential purposes\* if it is defective in materials or workmanship or if it stops functioning due to the failure of a component; or if the Toro GTS (Guaranteed to Start) engine will not start on the first or second pull, provided the routine maintenance required in the *Operator's Manual* have been performed.

This warranty covers the cost of parts and labor, but you must pay transportation costs.

The following time periods apply from the date of purchase:

Products	Warranty Period
Super Recycler® Mowers	5 year full warranty
Super Bagger Mowers	5 year full warranty
GTS (Guaranteed to Start)	5 year full warranty
Accessories (for above mowers)	5 year full warranty
Battery	1 year full warranty

**Limited Warranty for Commercial Use**

Gas-powered Toro Products used for commercial, institutional, or rental use, are warranted for 45 days against defects in materials or workmanship. Components failing due to normal wear are not covered by this warranty.

The Toro GTS (Guaranteed to Start) Starting Guarantee does not apply when the product is used commercially\*.

**Instructions for Obtaining Warranty Service**

If you think that your Toro Product contains a defect in materials or workmanship, follow this procedure:

1. Contact any Authorized Toro Service Dealer to arrange service at their dealership. To locate a dealer convenient to you, refer to the *Yellow Pages* of your telephone directory (look under "Lawn Mowers") or access our web site at [www.Toro.com](http://www.Toro.com). You may also call the numbers listed in item #3 to use the 24-hour Toro Dealer locator system.
2. Bring the product and your proof of purchase (sales receipt) to the Service Dealer. The dealer will diagnose the problem and determine if it is covered under warranty.
3. If for any reason you are dissatisfied with the Service Dealer's analysis or with the assistance provided, contact us at:

Customer Care Department, RLC Division  
 Toro Warranty Company  
 8111 Lyndale Avenue South  
 Bloomington, MN 55420-1196  
 Toll free at 888-865-5688 (U.S. customers)  
 Toll free at 888-865-5705 (Canadian customers)

**Owner Responsibilities**

You must maintain your Toro Product by following the maintenance procedures described in the *Operator's Manual*. Such routine maintenance, whether performed by a dealer or by you, is at your expense.

**Countries Other than the United States or Canada**

Customers who have purchased Toro products exported from the United States or Canada should contact their Toro Distributor (Dealer) to obtain guarantee policies for your country, province, or state. If for any reason you are dissatisfied with your Distributor's service or have difficulty obtaining guarantee information, contact the Toro importer. If all other remedies fail, you may contact us at Toro Warranty Company.

\*Residential purposes means use of the product on the same lot as your home. Use at more than one location, or institutional or rental use, is considered commercial use, and the commercial use warranty would apply.

**Items and Conditions Not Covered**

There is no other express warranty except for special emission system coverage and engine warranty coverage on some products. This express warranty does not cover the following:

- Cost of regular maintenance service or parts, such as filters, fuel, lubricants, oil changes, spark plugs, air filters, blade sharpening or worn blades, cable/linkage adjustments, or brake and clutch adjustments
- Any product or part which has been altered or misused and requires replacement or repair due to accidents or lack of proper maintenance
- Repairs necessary due to failure to use fresh fuel (less than one month old), or failure to properly prepare the unit prior to any period of non-use over one month
- Pickup and delivery charges
- Operational misuse, neglect, or accidents
- Repairs or attempted repairs by anyone other than an Authorized Toro Service Dealer
- Repairs or adjustments to correct starting difficulties due to the following:
  - failure to follow proper maintenance procedures
  - rotary mower blade striking an object
  - contaminants in the fuel system
  - improper fuel (consult your *Operator's Manual* if in doubt)
  - failure to drain the fuel system prior to any period of non-use over one month
- Special operational conditions where starting may require more than two pulls:
  - first time starts after extended period of non-use over one month or seasonal storage
  - cool temperature starts such as those found in early spring and late autumn
  - improper starting procedures - if you are having difficulty starting your unit, please check the *Operator's Manual* to ensure that you are using the correct starting procedures. This can save an unnecessary visit to an Authorized Toro Service Dealer.

**General Conditions**

All repairs covered by these warranties must be performed by an Authorized Toro Service Dealer using Toro approved replacement parts. Repair by an Authorized Toro Service Dealer is your sole remedy under this warranty.

**Neither The Toro Company nor Toro Warranty Company is liable for indirect, incidental, or consequential damages in connection with the use of the Toro Products covered by these warranties, including any cost or expense of providing substitute equipment or service during reasonable periods of malfunction or non-use pending completion of repairs under these warranties.**

Some states do not allow exclusions of incidental or consequential damages, or limitations on how long an implied warranty lasts, so the above exclusions may not apply to you.

This warranty gives you specific legal rights, and you may also have other rights which vary from state to state.