



## Multi-Pro<sup>®</sup> 1250 Turf Sprayer

Model No. 41163 - 240000001 and up.

### Parts Catalog

---

#### Ordering Replacement Parts

To order replacement parts, please supply the part number, the quantity, and the description of each part desired.

#### Understanding Reference Numbers

Each identified part in an illustration has a reference number. The reference number for a part also appears in the parts list, along with other information about the part.

This catalog uses two special reference number formats, one to indicate parts in a service assembly and another to indicate the quantity of a given part in an illustration.

#### Service Assembly Reference Numbers

Parts in service assemblies have reference numbers in the form a:b. The a represents the reference number of the entire service assembly and the b represents a sequential number unique to each part within the service assembly.

For example, a wheel assembly might be identified by reference number 6, the tire by 6:1, the valve by 6:2, and the wheel by 6:3. When you order the assembly identified by reference number 6, you receive all parts identified by reference numbers 6:1, 6:2, and 6:3. However, you may also order any part individually. Reference numbers of this type appear in illustrations and in part lists.

#### Reference Numbers Indicating Quantity

In an illustration, if a reference number indicates more than one part, the reference number has the form nX y. The n represents the quantity of the part, the X is the multiplication symbol, and the y represents the reference number.

For example, in an illustration, the reference number 2X 37 means that two of the parts identified by reference number 37 are indicated.

# Contents

<b>Description</b>	<b>Page</b>	<b>Description</b>	<b>Page</b>
Front Suspension Assembly	..... 4	Sprayer Component Assembly No.1	..... 43
Hydraulic Cylinder Assembly No. 100-8278	..... 5	Sprayer Component Assembly No. 2	..... 44
Engine Cover Assembly	..... 6	Tank Drain Assembly	..... 45
Seat Support Assembly	..... 8	Top Mounted Suction Assembly	..... 46
Brake and Accelerator Pedal Assembly	..... 9	Lower Sprayer Component Assembly	..... 47
Master Cylinder Assembly No. 94-3800	..... 10	Safety Valve Assembly No. 100-6820	..... 48
Rear Fender and Battery Mount Assembly	..... 11	Hose Assemblies No. 1	..... 49
Right Hand Boom Mount Assembly No. 106-4960	..... 13	Hose Assemblies No. 2	..... 50
Left Hand Boom Mount Assembly	..... 14	Transaxle Case Assembly Transaxle Assembly No. 104-9078	..... 51
EVC Control Valve Assembly	..... 15	Transaxle Gear Shaft Assembly Transaxle Assembly No. 104-9078	..... 52
Fresh Water Tank Assembly	..... 17	Countershaft Assembly Transaxle Assembly No. 104-9078	..... 53
Main Tank Assembly	..... 18	Shift Fork Assembly Transaxle Assembly No. 104-9078	..... 54
Lid Assembly	..... 19	Differential Gear Assembly Transaxle No. 104-9078	..... 55
Shifter Assembly	..... 20	Vehicle Electrical Schematic	..... 56
Parking Brake and Console Assembly	..... 21	Vehicle Hydraulic System	..... 57
Front Wheel Assembly	..... 22	Spray System Electrical Schematic	..... 58
Front Brake Assembly No. 100-8285	..... 23	Spray System Flow Diagram	..... 59
Transaxle Installation Assembly	..... 24	Crankshaft Assembly Kohler CH20S-64647	..... 60
Rear Wheel Assembly	..... 25	Crankcase Assembly Kohler CH20S-64647	..... 61
Rear Brake Assembly No. 93-7125 (Right) and 93-7126 (Left)	..... 26	Oil Pan / Lubrication Assembly Kohler CH20S-64647	..... 62
Driveshaft Assembly No. 98-2918	..... 27	Head / Valve / Breather Assembly Kohler CH20S-64647	..... 63
Engine Installation Assembly	..... 28	Ignition / Electrical Assembly Kohler CH20S-64647	..... 64
Gearbox Assembly No. 99-0663	..... 30	Blower Housing and Baffle Assembly Kohler CH20S-64647	..... 65
Drive Pulley Assembly No. 100-8289	..... 31	Starting System Kohler CH20S-64647	..... 66
Steering Pump Assembly No. 100-8302	..... 32	Fuel System Assembly Kohler CH20S-64647	..... 67
Driver Clutch Assembly No. 100-8288	..... 33	Engine Control Kohler CH20S-64647	..... 68
Pump Installation Assembly	..... 34	Air Intake / Filtration Assembly Kohler CH20S-64647	..... 69
Pump Assembly No. 106-5121	..... 35	Exhaust Assembly Kohler CH20S-64647	..... 70
Hydraulic Brake Line Assembly	..... 36		
Tank and Saddle Assembly	..... 37		
Throttle Linkage Assembly	..... 38		
Exhaust Assembly	..... 39		
Electrical Panel Assembly	..... 40		
Hydraulic Hose Routing Assembly	..... 41		
Steering Control Assembly No. 92-3502	..... 42		

## Part Description Abbreviations

Part descriptions in this catalog may include the following abbreviations.

AR. ....	as required	HWHTF. ....	hex washer head thread forming
ASM. ....	assembly	HYD. ....	hydraulic
BBC. ....	blade brake clutch	LH. ....	left hand
CARR. ....	carriage	NI. ....	nylon insert
CCW. ....	counter clock wise	NPTF. ....	national pipe thread fine
CW. ....	clockwise	PFH. ....	phillips flat head
DEG. ....	degrees	PPH. ....	phillips pan head
ECM. ....	electronic control module	PPHTF. ....	phillips pan head thread forming
EXT. ....	external	PRH. ....	phillips round head
FH. ....	flat head	PTH. ....	phillips truss head
GA. ....	gauge	PTO. ....	power-take-off
HD. ....	heavy-duty	RH. ....	right hand
HF. ....	hex flange	ROPS. ....	roll-over protection system
HH. ....	hex head	SFH. ....	slotted fillister head
HHF. ....	hex head flange	SHH. ....	slotted hex head
HHFTF. ....	hex head flange thread forming	SHWH. ....	slotted hex washer head
HJ. ....	hex jam	SPH. ....	slotted pan head
HLH. ....	hex lag head	SQH. ....	square head
HOC. ....	height-of-cut	SRH. ....	slotted round head
HSBH. ....	hex socket button head	STD. ....	standard
HSFH. ....	hex socket flat head	TAP. ....	self tapping
HSH. ....	hex socket head	TTH. ....	torx truss head
HWH. ....	hex washer head		

## Footnotes

- ❶ Not illustrated
- ❷ Not serviced separately
- ❸ Obtain Parts From Kohler

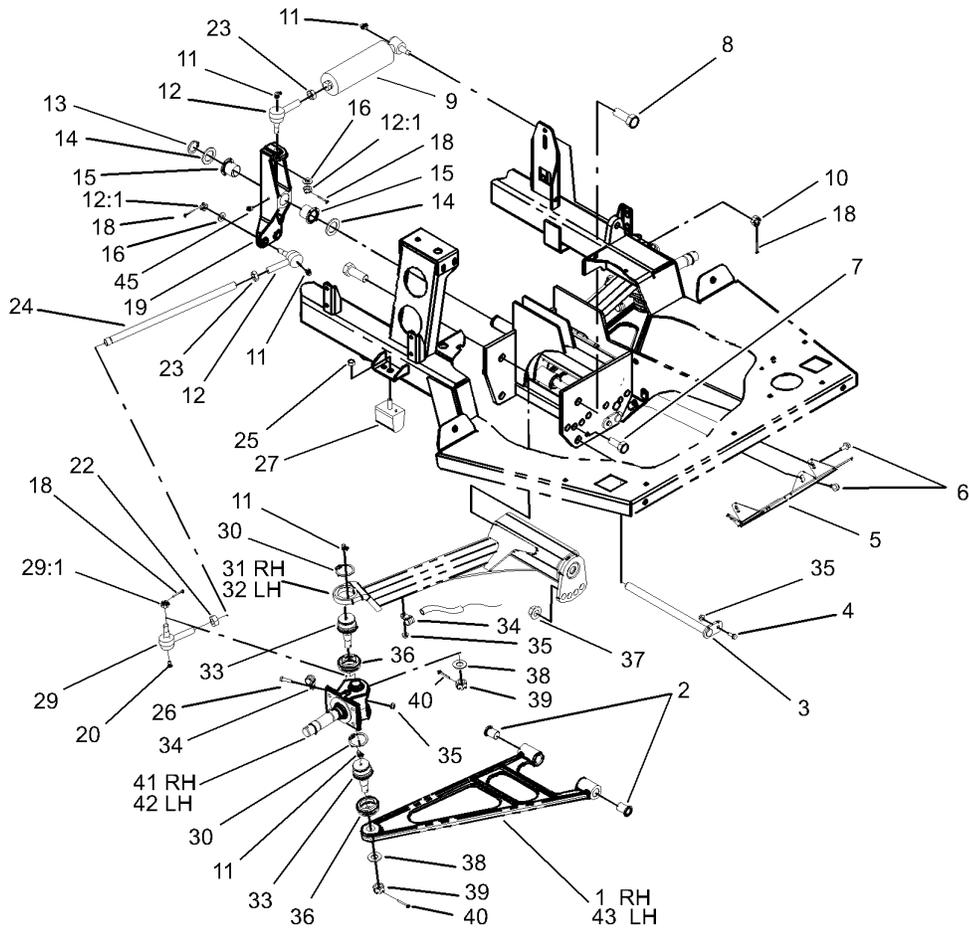

## Front Suspension Assembly

Ref	Part No.	Qty.	Description
1	100-6744-03	1	RH A-Arm ASM
2	100-8541	4	Bushing-A Arm
3	100-8544	2	Pivot Pin ASM
4	3234-4	2	Screw-HHF
5	100-7060-03	1	Plate-Skid
6	3234-5	4	Screw-HHF
7	327-4	2	Screw-HH
8	328-24	4	Screw-HH
9	100-8278	1	Cylinder-Steering
10	32136-13	1	Nut-SHH
11	302-60	8	Fitting-Grease, 90 DEG
12	112772	3	Joint-Ball, RH
12:1	915031	1	Nut
13	100-6785	1	Ring-Retaining
14	3-6781	2	Washer-Thrust
15	256-318	2	Bearing-Nyliner
16	3256-25	3	Washer-Flat
18	3272-11	6	Pin-Cotter
19	100-6774-03	1	Pivot-Steering
20	302-5	2	Fitting-Grease
22	3218-21	2	Nut-Jam
23	3220-11	3	Nut-Jam
24	100-8534-03	2	Tie Rod-Steering
25	48-9520	2	Nut

Ref	Part No.	Qty.	Description
26	321-6	2	Screw-HH
27	87-3470	2	Bumper-Axle, Rear
29	112771	2	Joint-Ball, LH
29:1	915031	1	Nut
30	32151-104	4	Ring-Retaining, External
31	100-8414	1	RH Axle ASM
32	100-8413	1	LH Axle ASM
33	87-1430	4	Joint-Ball
34	2412-134	4	Clamp-R
35	32128-33	6	Nut-HF
36	87-2420	4	Seal-Joint, Ball
37	32128-50	2	Nut-Flange
38	3256-27	4	Washer-Flat
39	32136-2	4	Nut-SHH
40	3272-17	4	Pin-Cotter
41	100-6738	1	Spindle-RH
42	100-6739	1	Spindle-LH
43	100-6745-03	1	LH A-Arm ASM
45	302-11	1	Fitting-Lube, 45 DEG



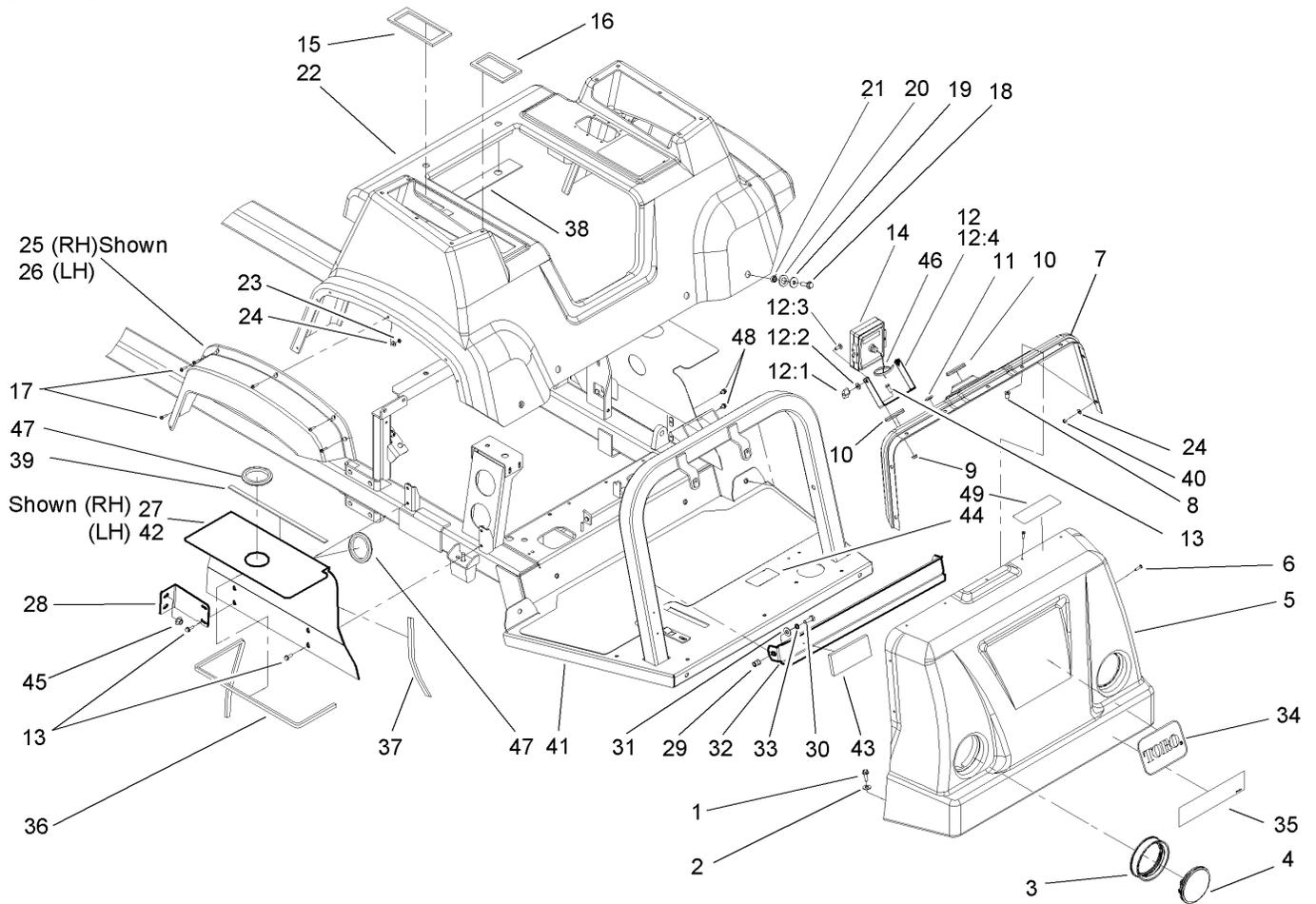

## Engine Cover Assembly

Ref	Part No.	Qty.	Description
1	3234-17	5	Screw-HHF
2	3256-3	5	Washer-Flat
3	99-7311	2	Mount-Headlight
4	99-7310	2	Headlight
5	100-8281	1	Hood-Front, Console
6	3250-25	9	Screw-PPH
7	100-6777	1	Dash Panel ASM
8	100-8450	15	Nut-Well
9	32128-33	2	Nut-HF
10	40764	2	Grommet
11	94-7290	1	Plug-Hole
12	100-6735	1	Monitor Mounting Bracket Kit
12:1	99-0667	2	Knob
12:2	99-0730	2	Washer-Rubber
12:3	106-4868	2	Screw-CARR
12:4	99-0576	1	Bracket
13	3234-4	8	Screw-HHF
14	104-8991	1	Monitor-Spray
15	100-8436	1	Seal-Foam
16	100-8437	1	Seal-Foam
17	3250-13	12	Screw-PPH
18	3234-24	6	Screw-HHF
19	356308	6	Washer-Special
20	100-8468	6	Washer-Rubber

Ref	Part No.	Qty.	Description
21	100-8464	6	Spacer
22	100-6776	1	Seat Base ASM
23	3217-26	12	Nut-Hex
24	3256-49	16	Washer-Flat
25	94-7074	1	Flare-Fender, RH
26	94-7075	1	Flare-Fender, LH
27	100-8443-03	1	Panel-Shield, RH
28	100-8623	2	Bracket-Engine Cover Support, Rear
29	92-3788	2	Insert
30	323-6	2	Screw-HH
31	3256-4	2	Washer-Flat
32	100-6731-03	1	Shield-Headlight
33	3253-21	2	Washer-Lock
34	62-5550	1	Decal
35	106-5128	1	Decal
36	100-8423	2	Trim-Shield, Top
37	100-8444	2	Trim-Shield, Front And Rear
38	100-8463	1	Seal-Foam
39	100-8499	2	Seal-Foam
40	3296-21	4	Nut-Lock, NI
41	100-8622	1	Tread-Floor
42	100-8448-03	1	Panel-Shield, LH
43	106-4872	2	Pad-Foam, Headlight



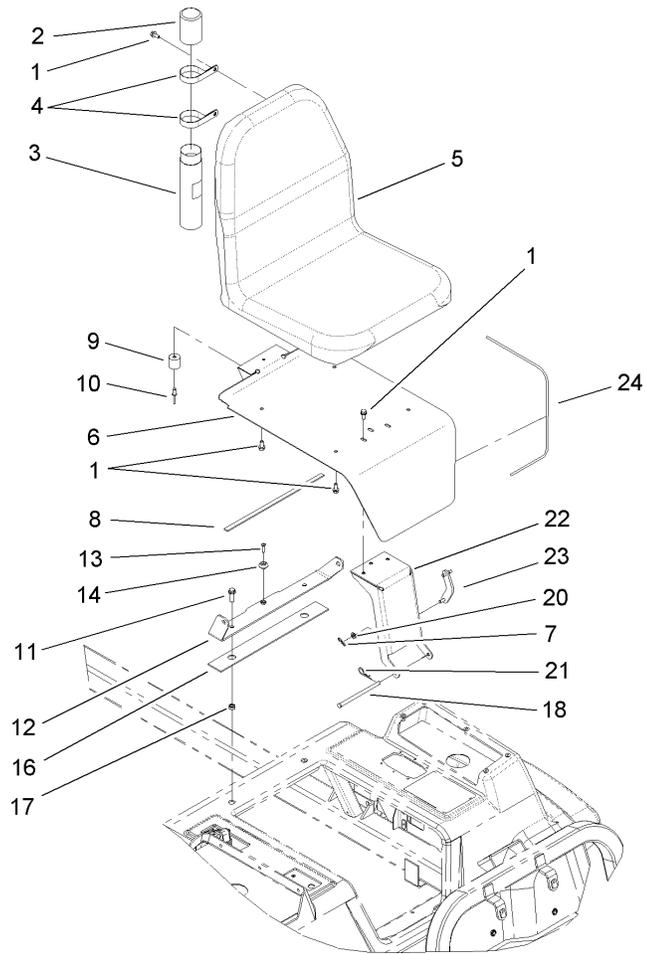

### Seat Support Assembly

Ref	Part No.	Qty.	Description
1	3234-5	9	Screw-HHF
2	104-7048	1	Cap-Housing
3	104-7050	1	Tube-Manual
4	2412-133	2	R-Clamp
5	104-4620	1	Seat
6	106-4856-03	1	Bracket-Seat
7	3290-307	1	Pin-Hair
8	100-8499	1	Seal-Foam
9	99-7830	1	Rubber Receptical ASM
10	3290-412	1	Rivet
11	3234-24	2	Screw-HHF
12	107-8614-03	1	Bracket-Seatbelt
13	32108-5	1	Screw-FH
14	99-7833	1	Post-Holding
16	100-8463	1	Seal-Foam
17	100-8464	2	Spacer
18	100-8501	1	Pin-Clevis
20	3256-23	1	Washer-Flat
21	9335054	1	Pin-Hair
22	106-4958-03	1	Bracket-Hinge
23	106-5171	1	Prop-Seat
24	100-8500	1	Trim-Seat

--	--	--	--

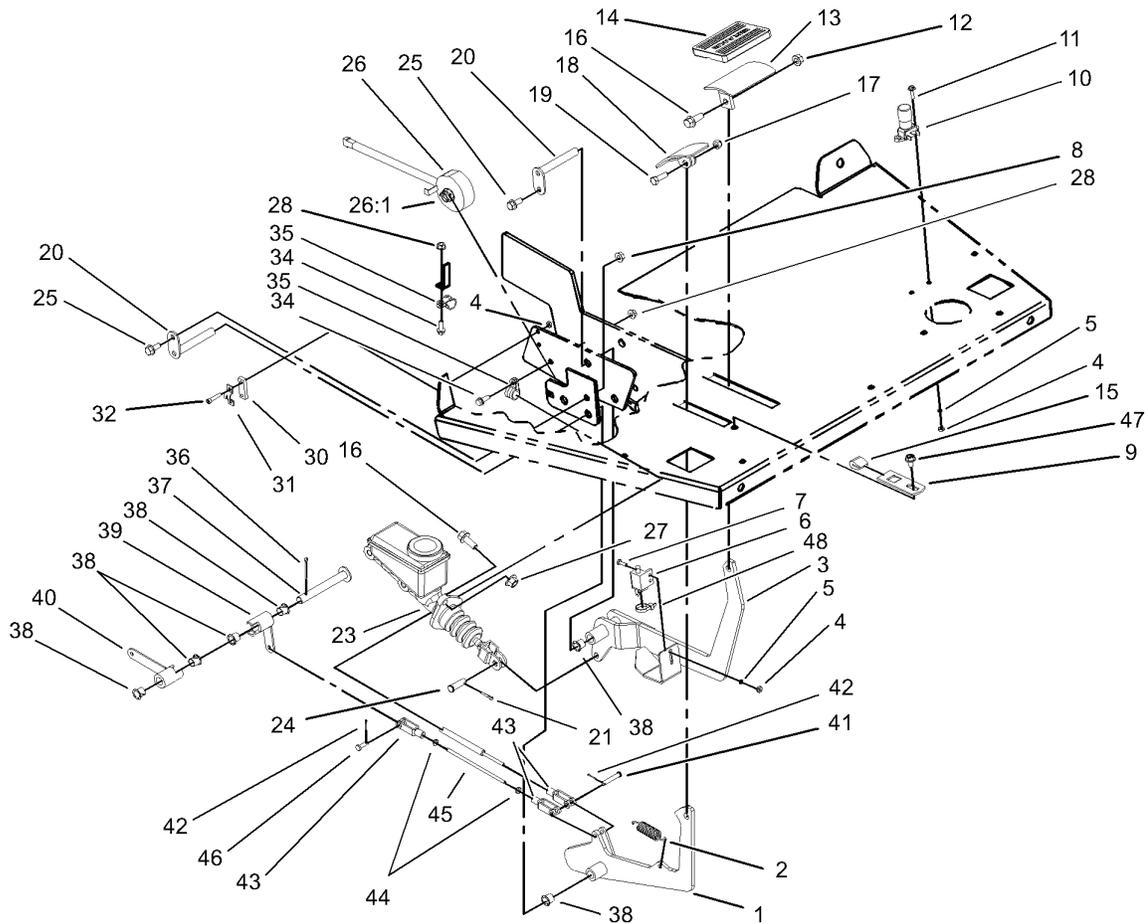

## Brake and Accelerator Pedal Assembly

Ref	Part No.	Qty.	Description
1	100-8367-03	1	Accelerator-Lever
2	67-1450	1	Spring-Idler
3	100-8553-03	1	Brake-Lever
4	3217-26	6	Nut-Hex
5	3253-17	4	Washer-Lock
6	92-0305	1	Switch
7	3290-134	2	Screw
8	32128-20	2	Nut-HF
9	104-8791-03	1	Plate-Pedal, Stop
10	94-7170	1	Switch-Floor
11	32105-13	2	Screw-HWH
12	32128-21	1	Nut-HF
13	100-8422-03	1	Pedal Bracket ASM
14	7-3900	1	Pad-Brake
15	100-6702	3	Stop-Lever, Pedal
16	3234-11	3	Screw-HHF
17	32153-3	1	Nut-Hex, Side Deform
18	93-8969-03	1	Pedal
19	322-5	1	Screw-HH
20	100-8554	2	Pin-Pivot
21	3272-10	1	Pin-Cotter
23	94-3800	1	Master Cylinder ASM
24	283-2	1	Pin-Clevis
25	3234-5	2	Screw-HHF

Ref	Part No.	Qty.	Description
26	99-8090	1	Magnet ASM
26:1	93-6601	1	Spring-Compression
27	32128-43	2	Nut-Flange
28	32128-33	2	Nut-HF
30	100-8561	1	Plate-Spacer
31	100-8560	1	Bracket-Throttle
32	3274-81	2	Screw-HSH
34	3234-4	2	Screw-HHF
35	2412-134	2	Clamp-R
36	3272-12	1	Pin-Cotter
37	100-8517	1	Pivot Pin ASM
38	256-257	8	Bushing-Nyliner
39	100-8515	1	Arm-Actuator, Short
40	100-8512	1	Arm-Actuator, Long
41	283-66	1	Pin-Clevis
42	3272-1	3	Pin-Cotter
43	282-28	4	Clevis-Adjustable
44	3219-14	4	Nut-Hex
45	100-8562	1	Rod-Threaded
46	283-67	2	Pin-Clevis
47	3234-28	1	Screw-HHF
48	3290-379	4	Tie-Cable



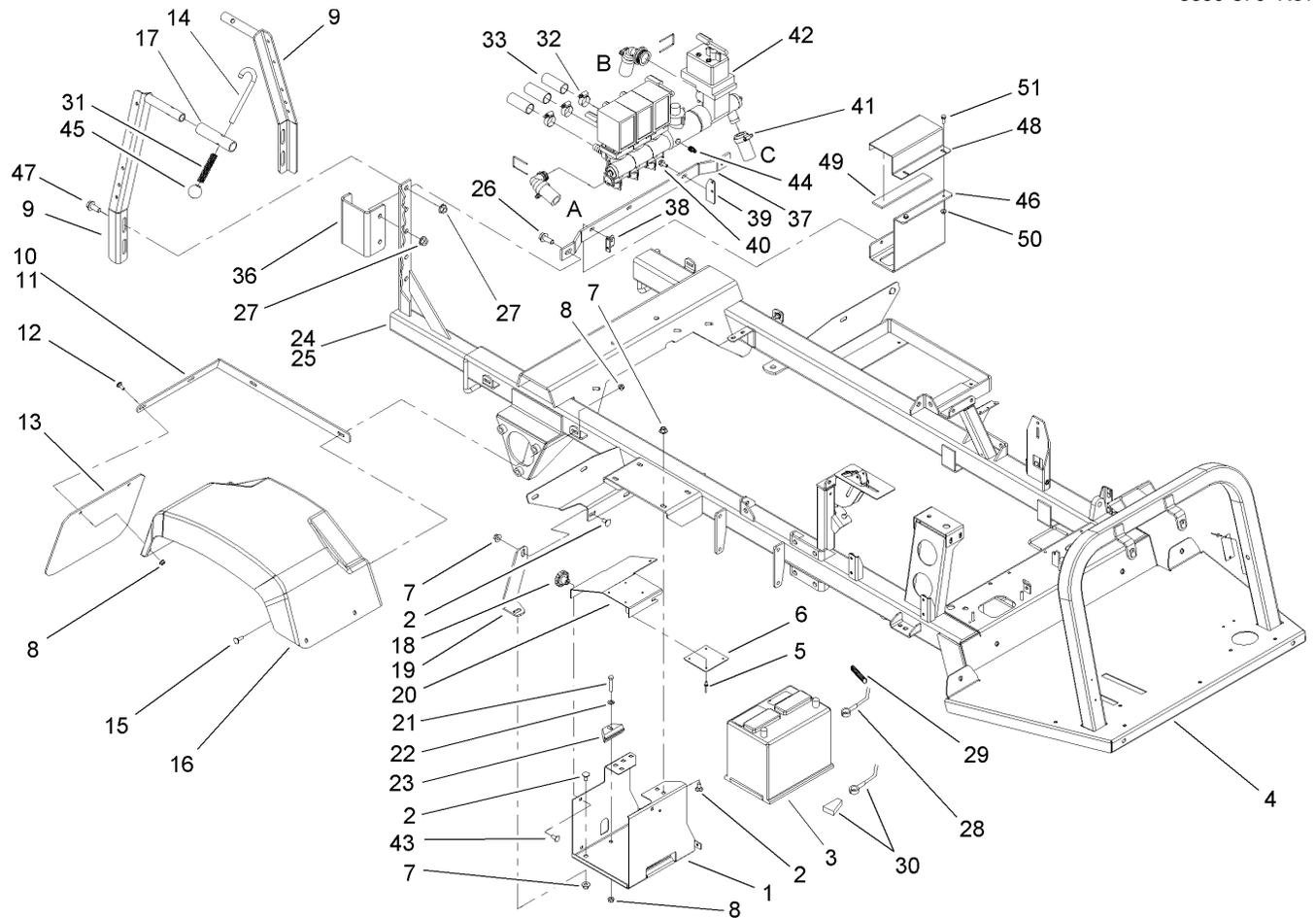

## Rear Fender and Battery Mount Assembly

Ref	Part No.	Qty.	Description
1	87-5120-03	1	Bracket-Holder, Battery
2	3231-1	4	Screw-CARR
3	106-5187	1	Battery
4	100-8339-03	1	Mainframe ASM
5	3269-27	4	Rivet-Snap
6	87-7620	1	Shield-Terminal, Battery
7	32128-43	4	Nut-Flange
8	32128-20	13	Nut-HF
9	106-5082-03	2	Hold-Boom
10	100-8246-03	1	Mount-Fender, RH
11	100-8245-03	1	Mount-Fender, LH
12	3230-1	8	Bolt-CARR
13	100-8259	2	Guard-Splash
14	92-8562	2	Hook-Restraint, Boom
15	3230-2	4	Bolt-CARR
16	93-6498	2	Fender-Rear
17	92-8561	2	Hose-Hold In
18	19-4050	2	Knob
19	100-8201-03	1	Support-Battery
20	87-5130-03	1	Cover-Battery
21	322-9	1	Screw-HH
22	3256-23	1	Washer-Flat
23	66-2490	1	Retainer-Battery
24	106-4960	1	LH Boom Mount ASM

Ref	Part No.	Qty.	Description
25	106-4961	1	RH Boom Mount ASM
26	3234-32	4	Screw-HHF
27	32128-49	10	Nut-HHF
28	99060	1	Cable-Ground
28:1	106-4915	1	Cap-Protective, Blue
29	104-8742	1	Conduit-Cable, Battery
30	106-5113	1	Cable-Battery, Positive
31	92-8563	2	Spring
32	2412-129	3	Clamp-Hose
33	41340	3	Hose-Boom
36	100-8431-03	2	Bracket-Mounting, Boom
37	100-8434-03	1	Bar-Valve Mounting
38	100-8432-03	2	Bracket
39	100-8433-03	1	Bracket
40	3234-5	3	Screw-HHF
41	2412-3	1	Clamp-Hose
42		1	Control-Valve, Evc
43	3230-23	2	Screw-CARR
44	100-8674	1	Coupler-Tube
45	92-8564	2	Knob
46	107-8611-03	1	Bracket-Valve, Boom
47	3234-32	4	Screw-HHF
48	107-8612-03	1	Bracket-Support, Valve
49	100-8524	1	Strip-Foam







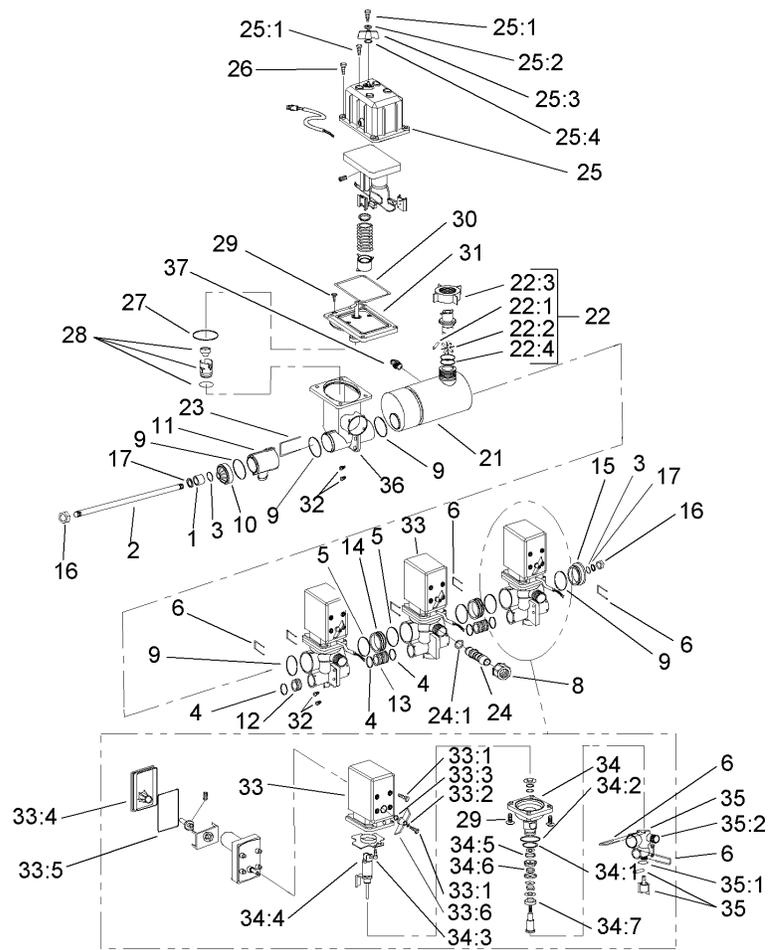

## EVC Control Valve Assembly

Ref	Part No.	Qty.	Description
1	100-6897	1	Bushing
2	100-6909	1	Rod-Threaded
3	100-6887	2	O-Ring
4	100-6882	5	O-Ring
5	100-6646	5	O-Ring
6	100-6885	9	Fork-Valve, Boom
8	99-0850	3	Nut
9	100-6892	4	O-Ring
10	100-6913	1	Cover
11	100-6908	1	T-Piece
12	100-6891	1	Cap-End
13	100-6890	2	Joiner-Bypass, Boom
14	100-6896	2	Joiner-Valve, Boom
15	100-6915	1	Cover-End
16	100-6894	2	Nut
17	100-6634	2	Washer
21	100-6920	1	Housing-Meter, Flow
22	100-6900	1	Flow Sensor ASM
22:1	100-6906	1	Shaft-Rotor
22:2	100-6919	1	Meter-Flow, Rotor
22:3	100-8678	1	Nut
22:4	100-8653	1	O-Ring
23	100-6907	1	Fork
24	106-5112	3	Hosebarb ASM

Ref	Part No.	Qty.	Description
24:1	100-6645	1	O-Ring
25	106-1358	1	Rate Control Motor ASM
25:1	100-6876	1	Screw
25:2	100-6877	1	Washer-Lock
25:3	100-6903	1	Grip-Hand
25:4	100-6880	1	O-Ring
26	100-6918	4	Screw-Plastic
27	100-6904	1	O-Ring
28	100-6905	1	Rate Valve Repair Kit
29	100-6917	16	Screw-Plastic
30	100-6901	1	Gasket-Housing, Valve Motor
31	100-6899	1	Section-Spindle, Valve Rate
32	100-6916	6	Screw-Plastic
33	107-2861	3	Boom Valve Motor ASM
33:1	100-6876	3	Screw
33:2	100-6877	3	Washer-Lock
33:3	100-6880	3	O-Ring
33:4	100-6874	3	Cover-Valve, Boom
33:5	100-6912	3	Cover-Seal
33:6	100-6875	3	Handgrip-Valve, Boom
34	100-6889	3	Section-Spindle, Boom Valve
34:1	100-8653	1	O-Ring
34:2	100-6882	5	O-Ring
34:3	100-6911	1	Pin-Roller

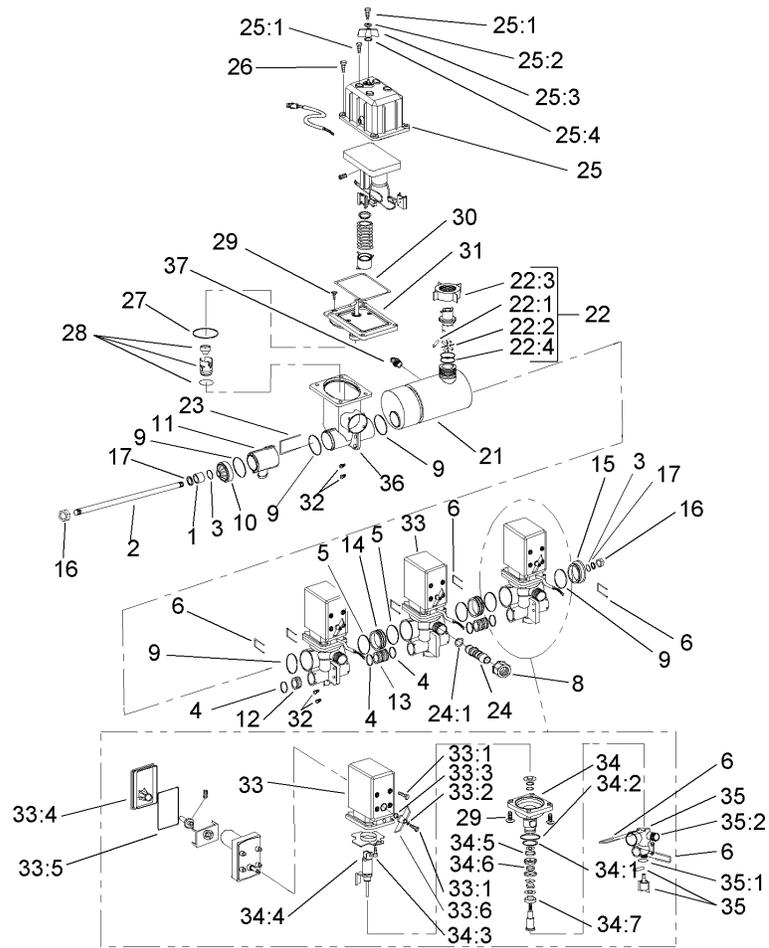

### EVC Control Valve Assembly (continued)

Ref	Part No.	Qty.	Description
34:4	100-6910	1	Bearing-Roller
34:5	100-6879	1	O-Ring
34:6	100-6878	1	O-Ring
34:7	100-6881	1	Cone-Stem, Boom Valve
35	100-6888	3	Manifold-Valve, Boom
35:1	100-6887	1	O-Ring
35:2	106-5151	1	Manifold-Lower
36	100-6914	1	Valve-Control, Housing Rate
37	100-8674	1	Coupler-Tube

--	--	--	--

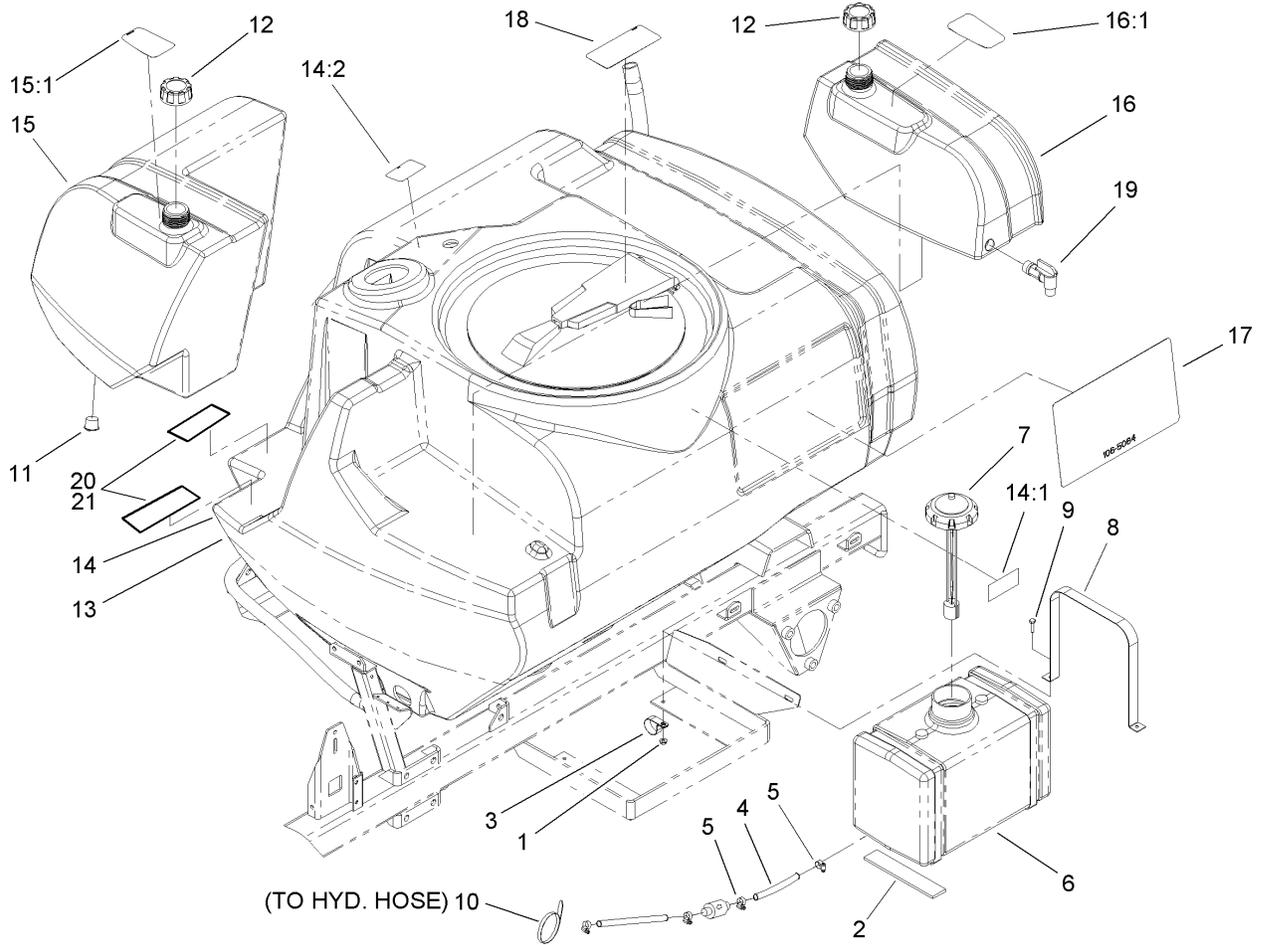

## Fresh Water Tank Assembly

Ref	Part No.	Qty.	Description
1	32128-33	4	Nut-HF
2	100-8524	2	Strip-Foam
3	2412-74	1	R-Clamp
4	100-8387	1	Hose-Fuel
5	2412-108	2	Clamp-Worm
6	100-8294	1	Tank-Fuel
7	100-8386	1	Fuel Cap And Guage ASM
8	106-4867-03	2	Strip-Hold Down, Gas Tank
9	321-6	4	Screw-HH
10	3290-379	4	Tie-Cable
11	107-8604	1	Plug-Tank
12	106-5052	2	Cap-Water, Fresh
13		1	Main Tank ASM
14	106-5045	1	175 Gallon Tank ASM
14:1	106-1355	1	Decal-No Tank Entry
14:2	106-5065	1	Decal-Drain, Tank
15	106-5046	1	20 Gallon Tank ASM
15:1	106-5050	1	Decal-Rinse, Tank
16	106-5047	1	5 Gallon Tank ASM
16:1	106-5051	1	Decal-Flush, Tank
17	106-5064	2	Decal-Profile, Low
18	93-0688	1	Decal-Warning, Chemical
19	106-4925	1	Spigot-90 DEG
20	107-8629	2	Pad-Rubber

Ref	Part No.	Qty.	Description
21	107-0377	3	Tape-Glue, 1/2In



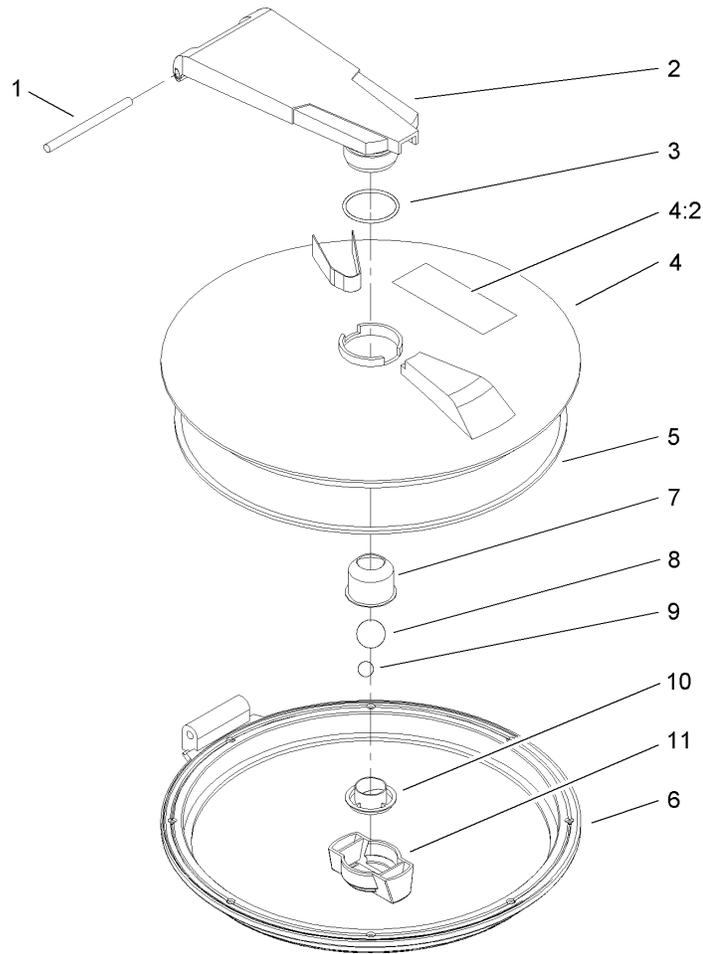

### Lid Assembly

Ref	Part No.	Qty.	Description				
1	106-5000	1	Pin-Pivot				
2	106-5001	1	Arm				
3	106-5002	1	O-Ring				
4	106-1369	1	Lid				
4:2	93-0688	1	Decal-Warning, Chemical				
5	106-5004	1	Seal-Lid				
6	106-5005	1	Ring				
7	106-5006	1	Cup-Vent				
8	106-5007	1	Ball-Floating				
9	106-5008	1	Ball-Weight				
10	106-5009	1	Holder-Ball				
11	106-5010	1	Nut-Wing				

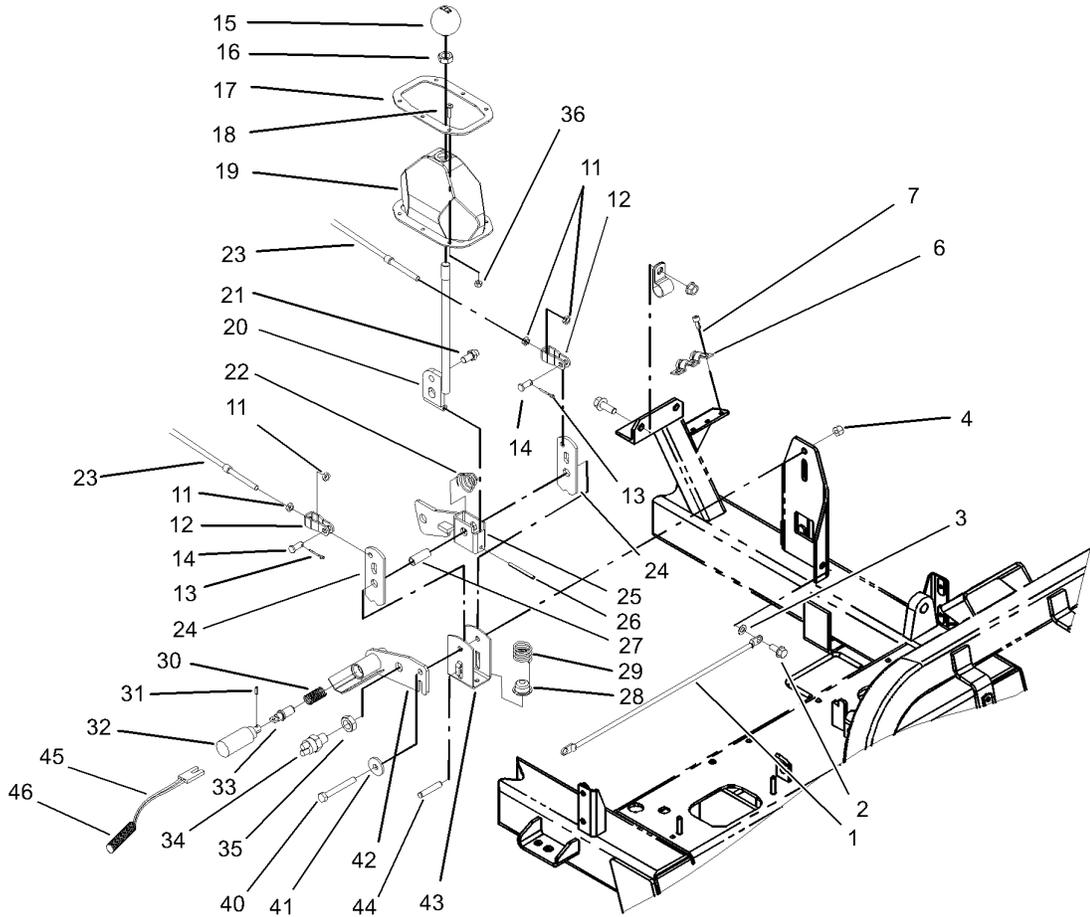

## Shifter Assembly

Ref	Part No.	Qty.	Description
1	42617	1	Cable-Ground
2	32144-41	1	Screw-Taptite
3	3255-8	1	Washer-Lock
4	3296-29	1	Nut-Lock, NI
6	87-4960	1	Clamp-Cable
7	65-5220	3	Screw-HSH, Thread Forming
11	3220-1	4	Nut-Jam
12	87-2310	2	Clevis-Cable
13	3272-6	2	Pin-Cotter
14	283-62	2	Pin-Clevis
15	87-6720	1	Knob-Shift
16	3218-18	1	Nut-Jam
17	87-3760-03	1	Plate-Boot, Shift
18	3250-13	6	Screw-PPH
19	87-8620	1	Shift Boot ASM
20	87-2040	1	Shift Lever ASM
21	87-3650	1	Pin-Shift
22	87-2900	1	Spring-Compression
23	100-8359	2	Cable-Shift
24	87-3540	2	Link-Shift
25	100-6749	1	Shifter Bracket ASM
26	32121-48	1	Pin-Spring
27	87-2520	1	Tube-Pivot
28	87-3530	1	Button-Shifter

Ref	Part No.	Qty.	Description
29	87-3660	1	Spring-Compression
30	100-6754	1	Spring-Compression
31	32121-7	1	Pin-Roll, Slotted
32	100-6741	1	Solenoid
33	100-6746	1	Pin-Limiter, Shift
34	83-1890	1	Switch-Ball
35	3220-11	1	Nut-Jam
36	3296-2	6	Nut-Lock, NI
40	322-12	1	Screw-HH
41	356303	1	Washer
42	100-6747	1	Solenoid Mount ASM
43	87-3520	1	Clevis
44	3290-507	1	Pin-Dowel
45	100-6751	1	Harness-Limiter, Shift
46	100-7072	1	Protector-Wire

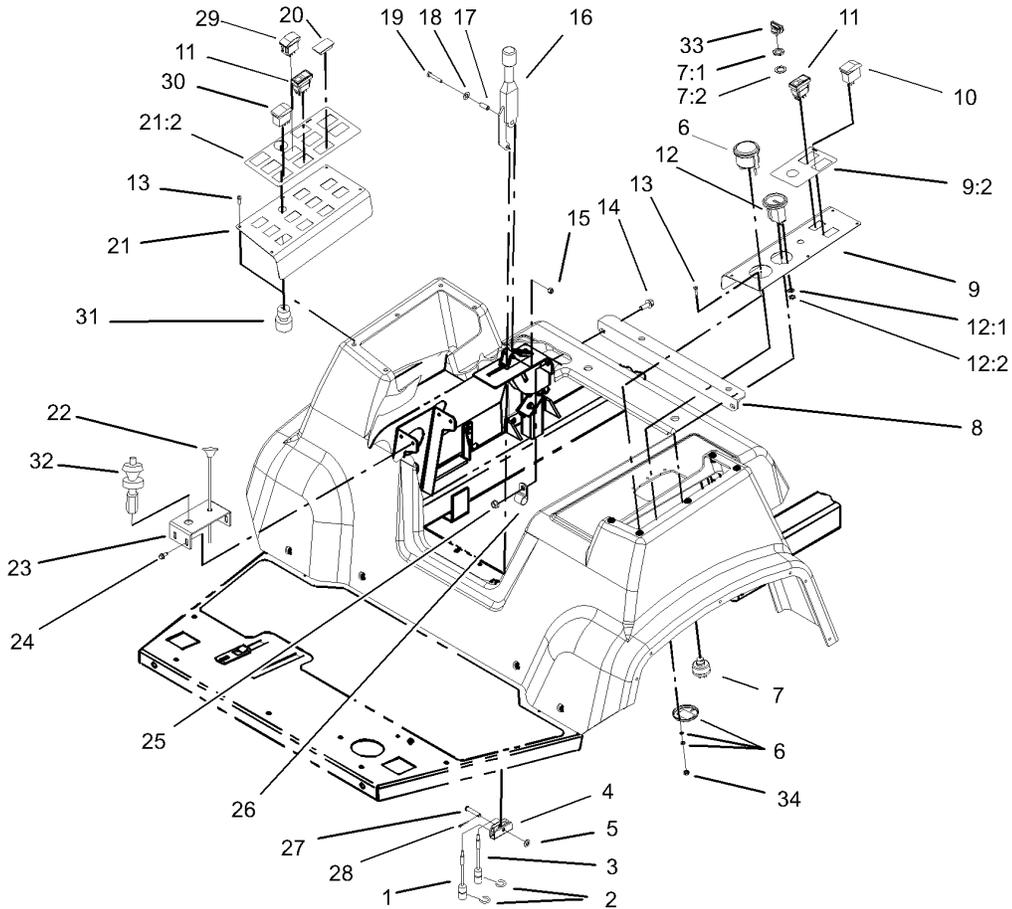

## Parking Brake and Console Assembly

Ref	Part No.	Qty.	Description
1	87-8240	1	Cable-Brake
2	32120-47	2	Ring-Retaining, External
3	100-8261	1	Cable-Park Brake, RH
4	87-3480	1	Bracket-Equalizer, Cable
5	3256-23	1	Washer-Flat
6	42610	1	Voltmeter
7	83-0020	1	Switch-Ignition
7:1	218-461	1	Nut-HH
7:2	3254-5	1	Washer-Tooth
8	106-4859-03	1	Bracket-Seatbox
9	100-8452	1	Vehicle Control Panel ASM
9:2	100-8470	1	Decal-Controls
10	100-8469	1	Switch-Rocker
11	104-9007	2	Switch-Rocker
12	66-2950	1	Gauge-Hourmeter
12:1	3255-20	2	Washer-Lock
12:2	3217-25	2	Nut-Hex
13	3250-25	10	Screw-PPH
14	3234-11	2	Screw-HHF
15	3296-42	1	Nut-Lock, NI
16	87-2710	1	Lever-Brake
17	87-4710	1	Spacer-Brake, Parking
18	3290-477	1	Washer-Curved
19	321-9	1	Screw-HH

Ref	Part No.	Qty.	Description
20	99-7420	5	Plug-Hole
21	100-8505	1	Spray Control Panel ASM
21:2	100-8489	1	Decal-Control, Spray
22	41697	1	Choke-Control
23	100-8385-03	1	Bracket-Speed, Throttle
24	32144-10	4	Screw-HWH
25	32128-21	2	Nut-HF
26	2412-81	2	Clamp-R
27	94-3829	1	Pin-Clevis
28	3272-6	1	Pin-Cotter
29	100-1535	1	Switch
30	100-8490	3	Switch-Dpdt
31	94-5245	1	Switch-Key
32	100-8384	1	Throttle Speed Control ASM
33	63-8360	1	Key-Ignition
34	32149-9	2	Nut-Keps

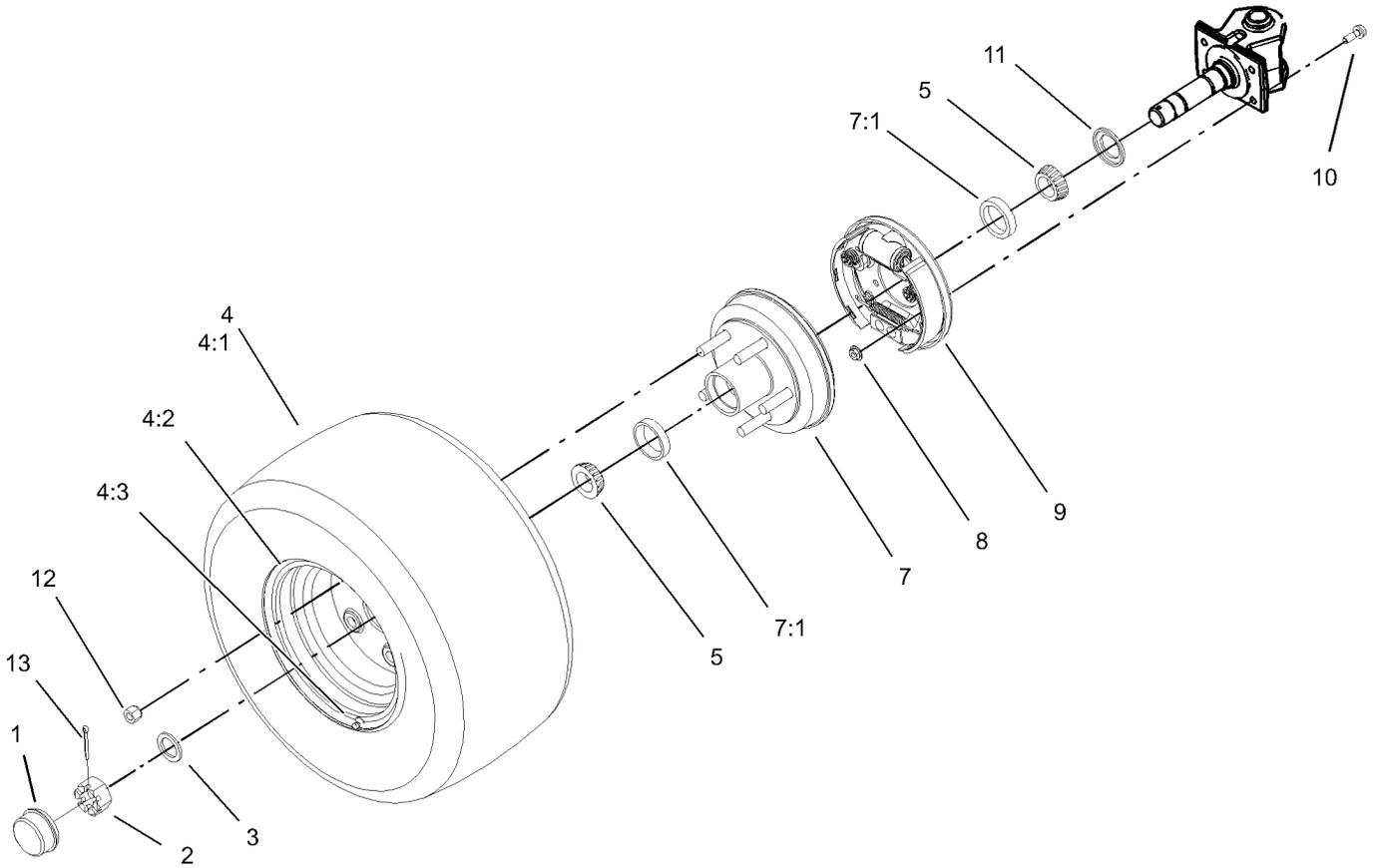

## Front Wheel Assembly

Ref	Part No.	Qty.	Description
1	241-119	2	Cap-Dust
2	1-809082	2	Nut-SHH
3	27-1850	2	Washer-Pivot
4	93-6487	2	Front Tire And Wheel ASM
4:1	93-6486	1	Tire
4:2	241-121	1	Wheel ASM
4:3	232-27	1	Stem-Valve
5	254-92	4	Cone-Bearing, Outer
7	100-8287	2	Hub/Drum-Front
7:1	254-72	2	Bearing-Cup, Tapered
8	32128-28	8	Locknut
9	100-8285	2	Front Brake ASM
10	86-8610	8	Screw-HHF
11	253-129	2	Seal
12	321077	10	Nut-Wheel
13	3272-13	2	Pin-Cotter

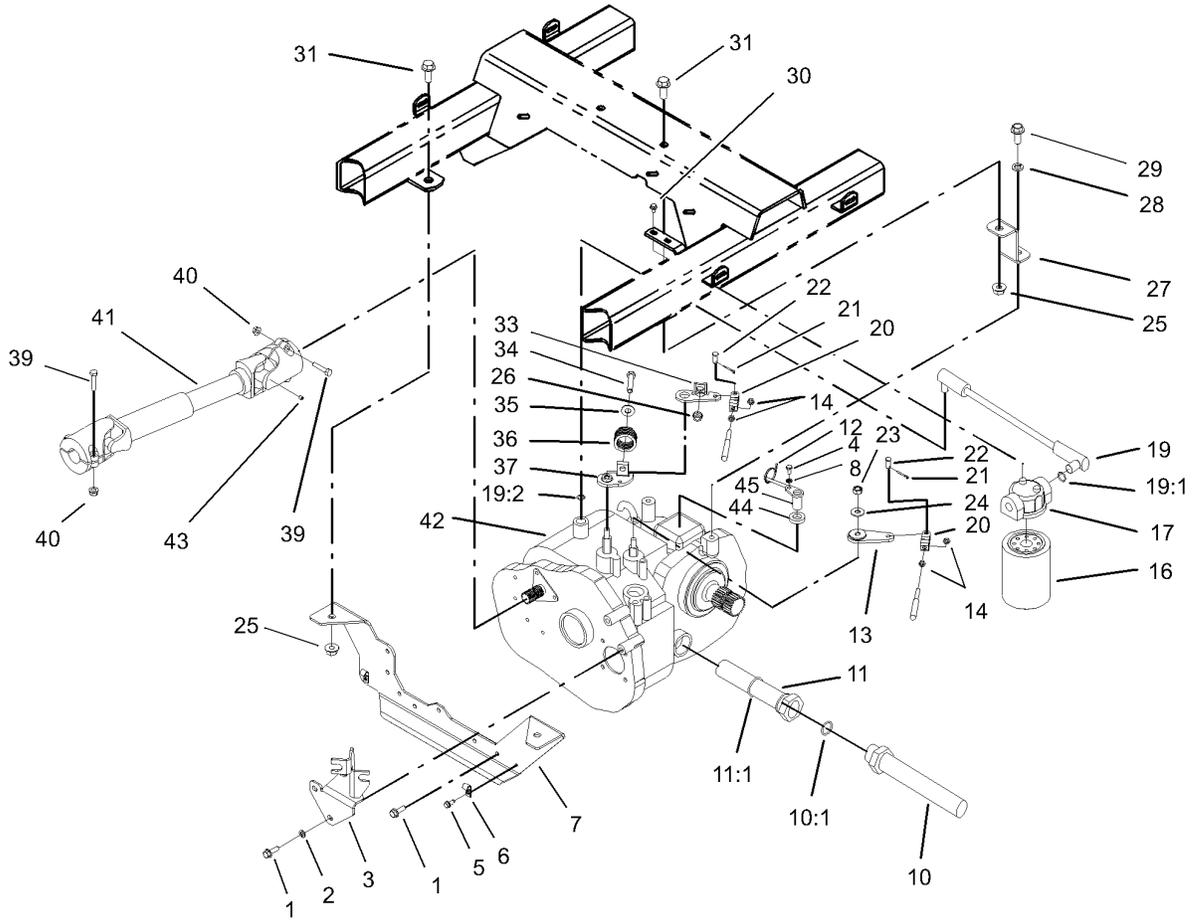

## Transaxle Installation Assembly

Ref	Part No.	Qty.	Description
1	33104-025	10	Screw-HHF
2	3253-4	10	Washer-Lock
3	100-8303-03	1	Mount-Cable
4	33113-012	1	Screw-HH
5	32144-10	2	Screw-HWH
6	2412-89	2	Clamp
7	100-8531-03	1	Transaxle-Mount
8	48-8020	1	Washer-Spring
10	100-8250	1	Hose-Suction
10:1	237-81	1	O-Ring
11	87-3990	1	Strainer-Transaxle
11:1	237-123	1	O-Ring
12	3290-379	4	Tie-Cable
13	87-7960	1	Lever-Shift
14	3220-1	4	Nut-Jam
16	54-0110	1	Filter-Oil, Transmission
17	87-8780	1	Head-Filter
19	100-8254	1	Hose-Return, Axle
19:1	237-79	1	O-Ring
19:2	237-42	1	O-Ring
20	87-2310	2	Clevis-Cable
21	3272-6	2	Pin-Cotter
22	283-62	2	Pin-Clevis
23	48-9520	2	Nut

Ref	Part No.	Qty.	Description
24	80-6990	2	Washer-Hardened
25	32128-49	2	Nut-HHF
26	32128-21	1	Nut-HF
27	100-8220-03	2	Strap-Mount, Transaxle
28	3253-7	2	Washer-Lock
29	33106-030	2	Screw-HHF
30	3234-33	2	Screw-HHF
31	3234-32	4	Screw-HHF
33	87-8250	1	Plate-Arm, Shift
34	323-10	1	Screw-HH
35	3256-4	1	Washer-Flat
36	87-6910	1	Spring-Compression
37	87-7970	1	Arm-Shift
39	322-7	4	Screw-HH
40	3296-29	4	Nut-Lock, NI
41	100-8293	1	Shaft-Drive, Input
42	104-9078	1	Transaxle
43	3245-32	1	Screw-HSH
44	92-3735	1	Seal-Oil, Sensor
45	85-4350	1	Sensor-Geartooth

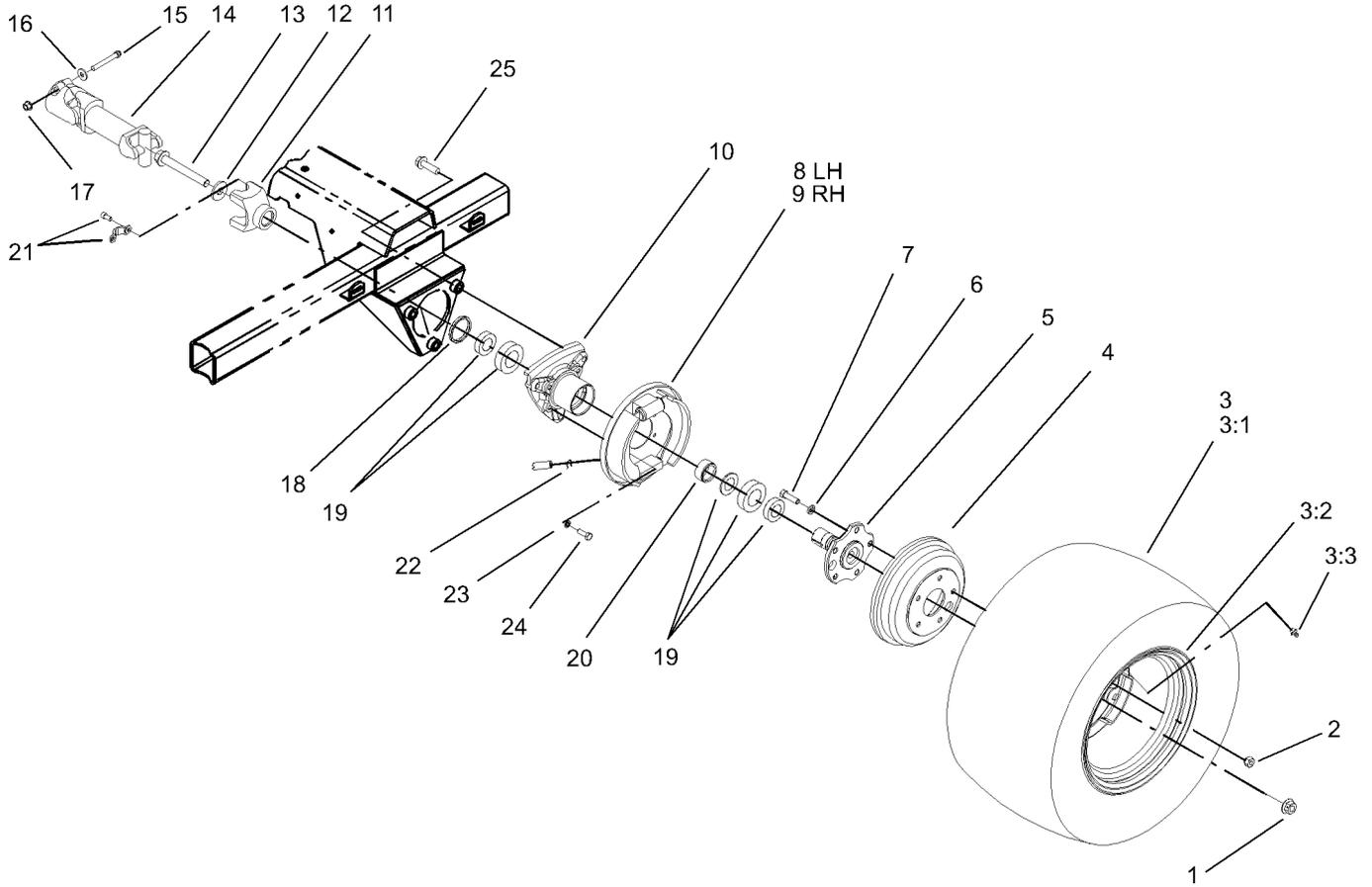

## Rear Wheel Assembly

Ref	Part No.	Qty.	Description
1	105-1764	2	Nut-Flange, Side Lock
2	321077	10	Nut-Wheel
3	87-5370	2	Rear Tire And Wheel ASM
3:1	87-6740	1	Tire
3:2	87-6750	1	Wheel
3:3	232-27	1	Stem-Valve
4	93-7128	2	Drum-Brake
5	105-1717-03	2	Axle-Stub
6	3253-6	10	Washer-Lock
7	87-2080	10	Bolt-Hex, TAP
8	93-7126	1	LH Rear Brake ASM
9	93-7125	1	RH Rear Brake ASM
10	87-2240-03	2	Housing-Axle
11	92-4190	2	Yoke
12	104-9216	2	Washer-Hardened
13	105-1763	2	Screw-HHF
14	98-2918	2	Driveshaft ASM
15	98-2939	4	Screw-Cap
16	80-6990	4	Washer-Hardened
17	32128-36	4	Nut-HF
18	87-3590	2	Seal-Bearing
19	87-1970	2	Bearing
20	87-4060	2	Spacer-Bearing, Wheel
21	92-4189	2	Strap Kit

Ref	Part No.	Qty.	Description
22	87-3310	2	Clip-Cable, Brake
23	3253-21	8	Washer-Lock
24	323-6	8	Screw-HH
25	3234-22	6	Screw-HHF

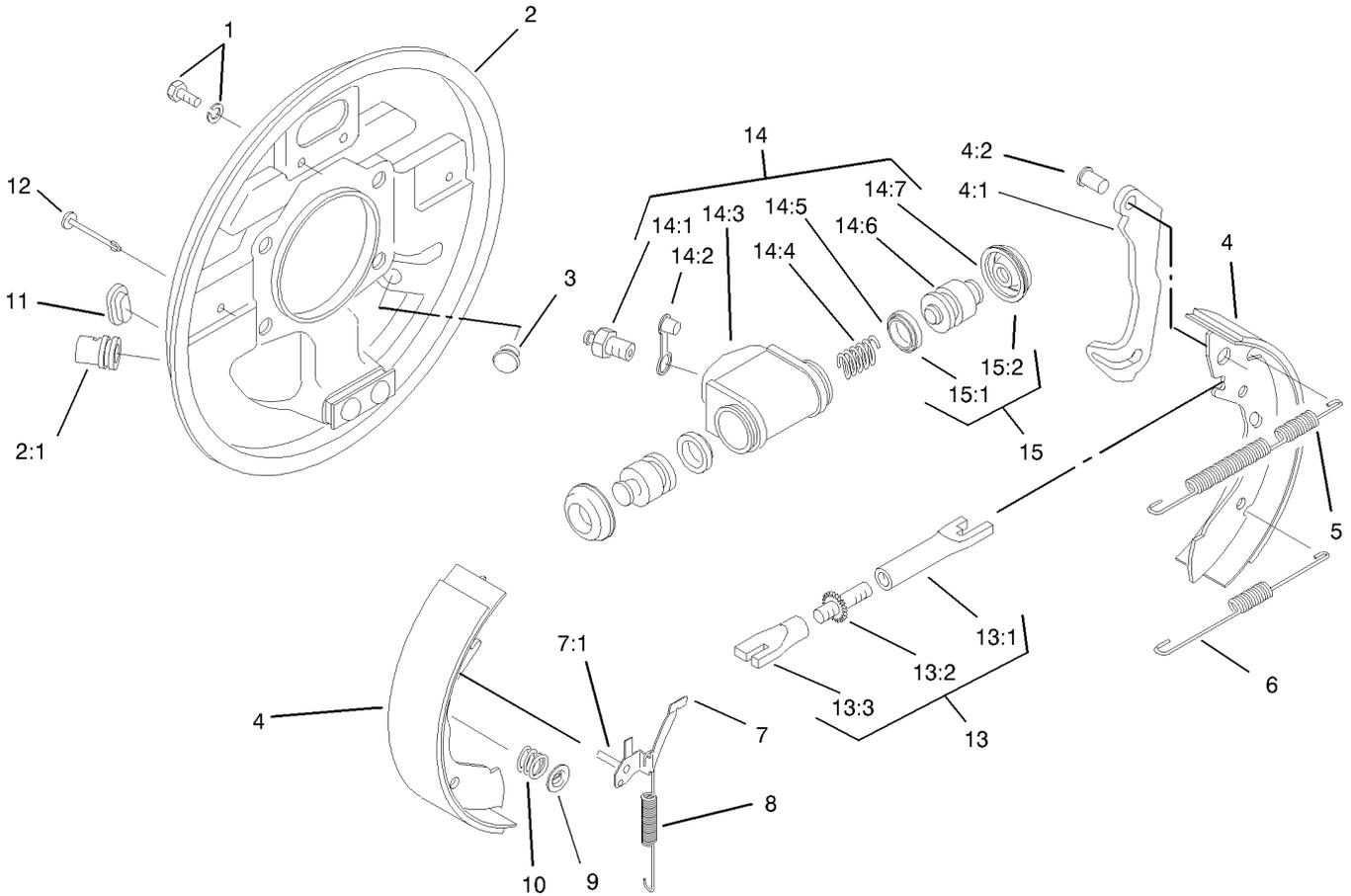

## Rear Brake Assembly No. 93-7125 (Right) and 93-7126 (Left)

Ref	Part No.	Qty.	Description
1	92-4135	2	Bolt-Set
2	92-4136	1	LH Backplate ASM
2	92-4100	1	RH Backplate ASM
②2:1		1	Guide-Pipe
3	92-4146	1	Plunger ASM
4	92-4143	1	Lined Shoe Kit
②4:1		1	Lever-Operating
②4:2		1	Pin
5	92-4147	1	Spring-Return, Shoe (Upper, LH)
5	92-4148	1	Spring-Return, Shoe (Upper, RH)
6	92-4149	1	Spring-Return, Shoe (Lower)
7	92-4124	1	RH Pawl Lever ASM
7	92-4123	1	LH Pawl Lever ASM
②7:1		1	Pin-Pawl
8	92-4150	1	Spring-Adjuster, LH
8	92-4151	1	Spring-Adjuster, RH
9	92-4131	2	Washer-Hold Down, Shoe
10	92-4152	2	Spring-Hold Down, Shoe
11	92-4134	1	Plug-Inspection
12	92-4133	2	Pin-Hold Down, Shoe
13	92-4144	1	LH Adjuster ASM
13	92-4145	1	RH Adjuster ASM
②13:1		1	Pushrod-Female
②13:2		1	Bolt-Adjuster

Ref	Part No.	Qty.	Description
②13:3		1	Sleeve-Adjuster
14	92-4141	1	RH Wheel Cylinder ASM
14	92-4140	1	LH Wheel Cylinder ASM
14:1	92-4137	1	Screw-Bleed
14:2	92-4114	1	Cap-Screw, Bleed
②14:3		1	Body
②14:4		1	Spring
②14:5		2	Seal-L Type
②14:6		2	Piston
②14:7		2	Cover-Dust
15	92-4142	1	Seal Kit
②15:1		2	Seal-L Type
②15:2		2	Cover-Dust

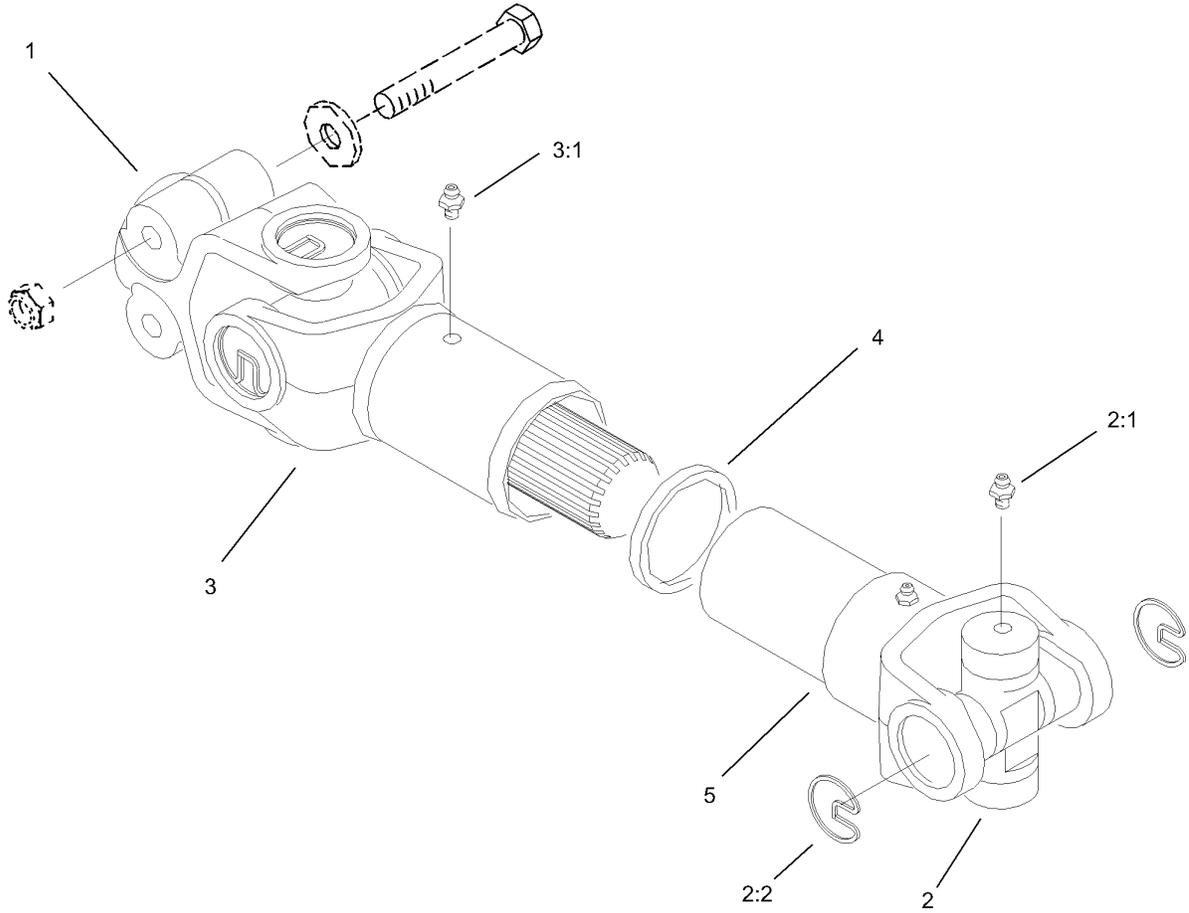

### Driveshaft Assembly No. 98-2918

Ref	Part No.	Qty.	Description
1	98-2940	1	Yoke
2	92-4187	2	Cross And Bearing Kit
2:1	302-58	2	Fitting-Straight
2:2	92-4188	2	Ring-Snap
3	92-4179	1	Yoke-Tube, Shaft And Seal
3:1	302-5	1	Fitting-Grease
4	92-4180	1	Seal
5	92-4182	1	Yoke-Telescoping

Ref	Part No.	Qty.	Description

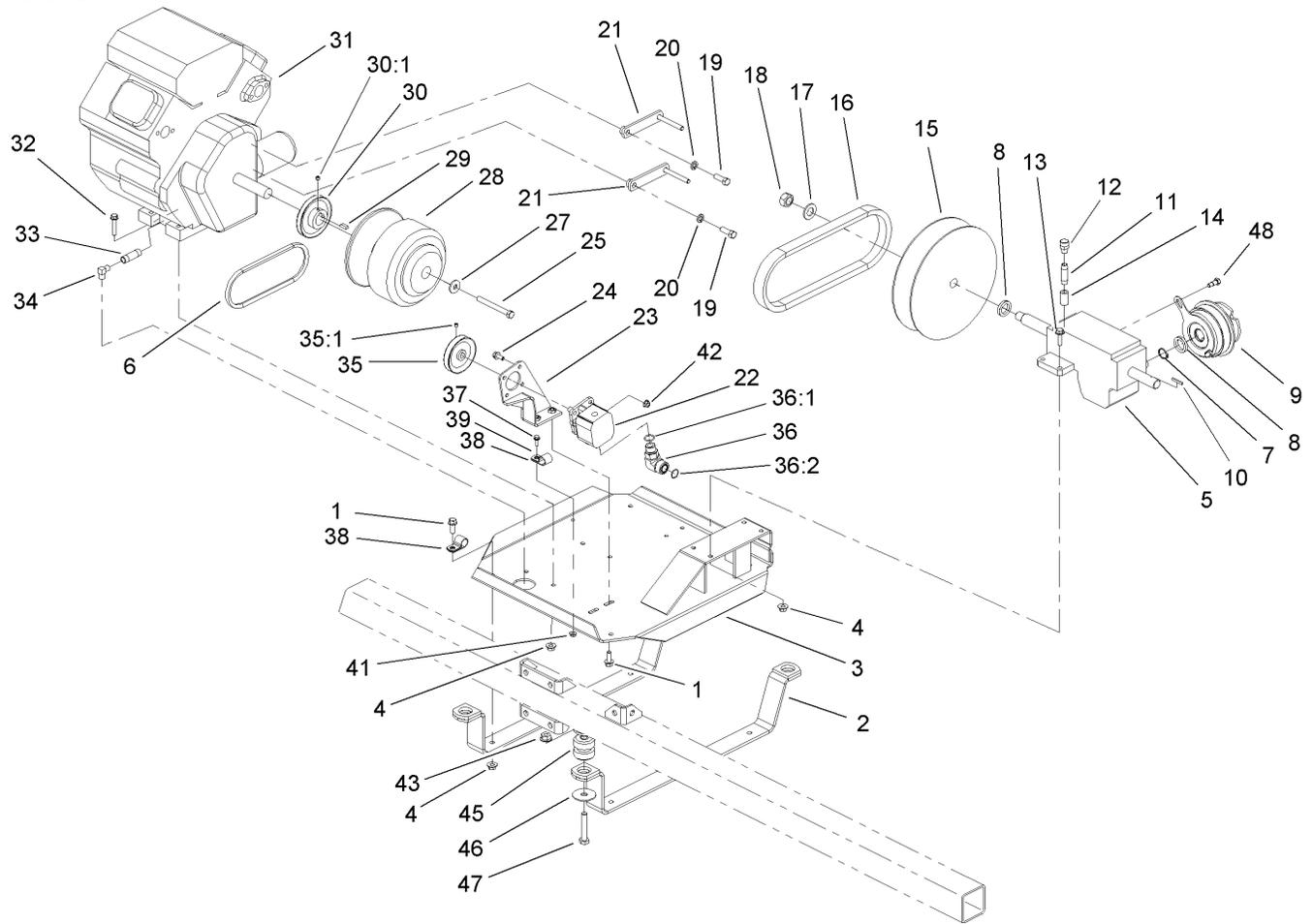

## Engine Installation Assembly

Ref	Part No.	Qty.	Description
1	3234-11	6	Screw-HHF
2	100-8377-03	2	Strap-Support, Engine
3	100-8357-03	1	Plate-Mounting, Engine
4	32128-43	12	Nut-Flange
5	99-0663	1	Gearbox-Pump Drive
6	100-8372	1	Belt-Steering
7	32151-36	1	Ring-Retaining
8	100-8390	2	Spacer
9	100-8290	1	Clutch-Electric, Pump (Drive)
10	92-0049	1	Key-Square
11	106-4869	1	Pipe-Coupling
12	100-6931	1	Breather
13	3234-24	4	Screw-HHF
14	104-8766	1	Nipple
15	100-8289	1	Drive Pulley ASM
16	99-0735	1	Belt-Cvt
17	3256-28	1	Washer-Flat
18	100-8486	1	Nut-Locking, LH
19	324-5	2	Screw-HH
20	3253-6	2	Washer-Lock
21	100-8373	2	Belt Guide ASM
22	100-8302	1	Pump-Steering
23	100-8368-03	1	Bracket-Pump, Steering
24	322-4	4	Screw-HH

Ref	Part No.	Qty.	Description
25	3212-16	1	Screw-HH
27	710128	1	Washer
28	100-8288	1	Clutch-Driver
29	100-8260	1	Key-Shaft
30	92-0488	1	Pulley-Pump
30:1	3246-2	1	Screw-Set, HSH
31	99-0819	1	Engine-Kohler, Ch20S Ps-64647
32	3234-19	4	Screw-HHF
33	92-3647	1	Nipple
34	95023	1	Elbow-90 DEG
35	100-8371	1	Pulley-Pump
35:1	3246-2	1	Screw-Set, HSH
36	340-16	1	Fitting-HYD, 90 DEG
36:1	237-80	1	O-Ring
36:2	237-58	1	O-Ring
37	3234-4	1	Screw-HHF
38	2412-81	3	Clamp-R
39	3256-22	1	Washer-Flat
41	32128-33	1	Nut-HF
42	32128-20	4	Nut-HF
43	32128-49	4	Nut-HHF
45	87-4970	4	Engine Mount ASM
46	41985	4	Washer-Special
47	325-11	4	Screw-HH



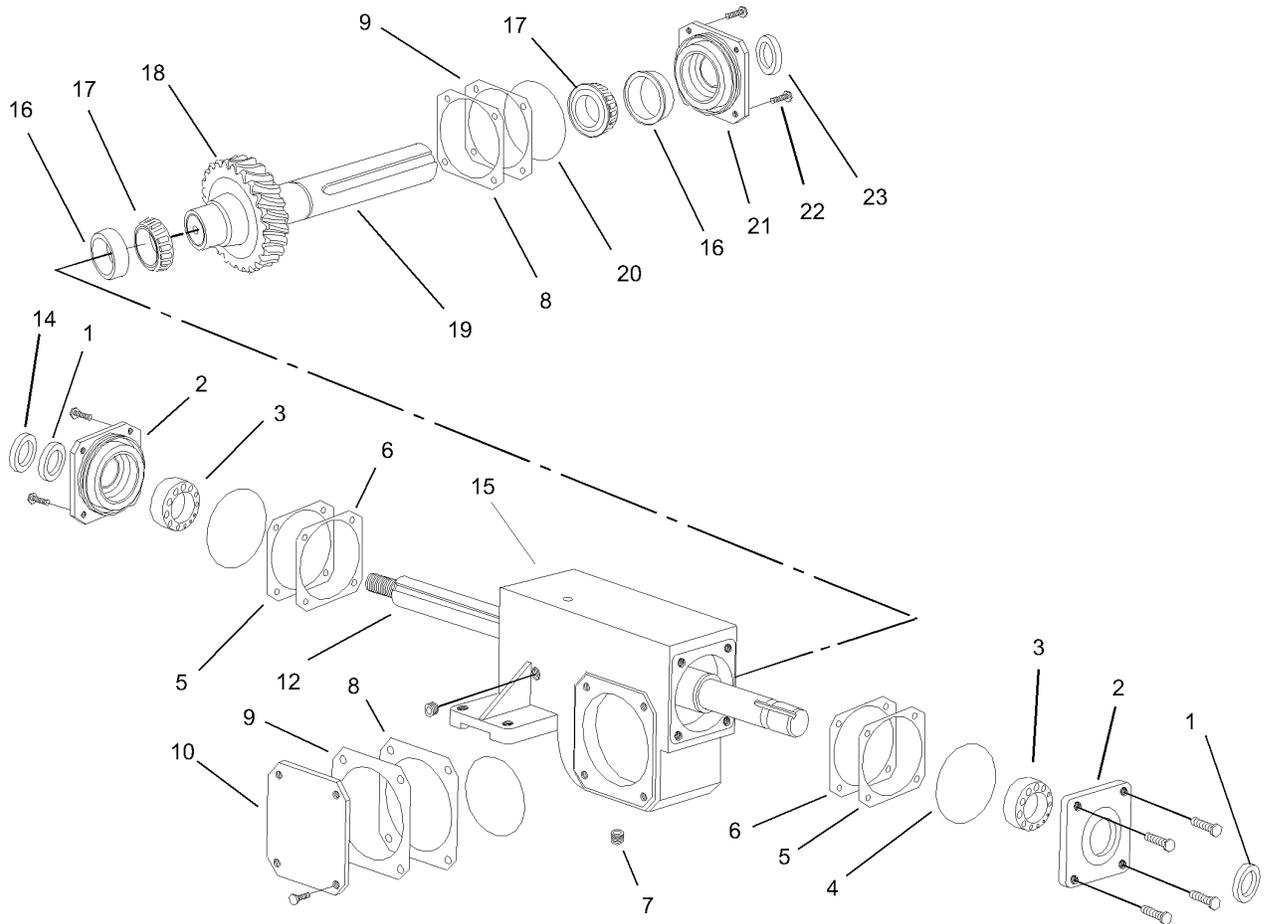

### Gearbox Assembly No. 99-0663

Ref	Part No.	Qty.	Description
1	100-6929	2	Seal
2	100-6930	2	Cap-Open
3	251-348	2	Bearing-Ball
4	100-6932	2	O-Ring
5	100-6933	1	Shim-Red, .002
6	100-6934	1	Shim-Blue, .005
7	281-10	2	Plug
8	100-6936	1	Shim-Blue, .005
9	100-6937	1	Shim-Red, .002
10	100-6938	1	Cap-Closed
12	100-6940	1	Shaft-Worm
14	100-8390	1	Spacer
15		1	Housing-Gearbox
16	254-72	2	Bearing-Cup, Tapered
17	254-94	2	Bearing-Cone, Tapered
18	100-6944	1	Gear-Worm, S/1
19	100-6946	1	Shaft-Output
20	237-161	2	O-Ring
21	100-6948	1	Cap-Open
22	321-3	16	Screw-HH
23	104-8764	1	Seal-Viton

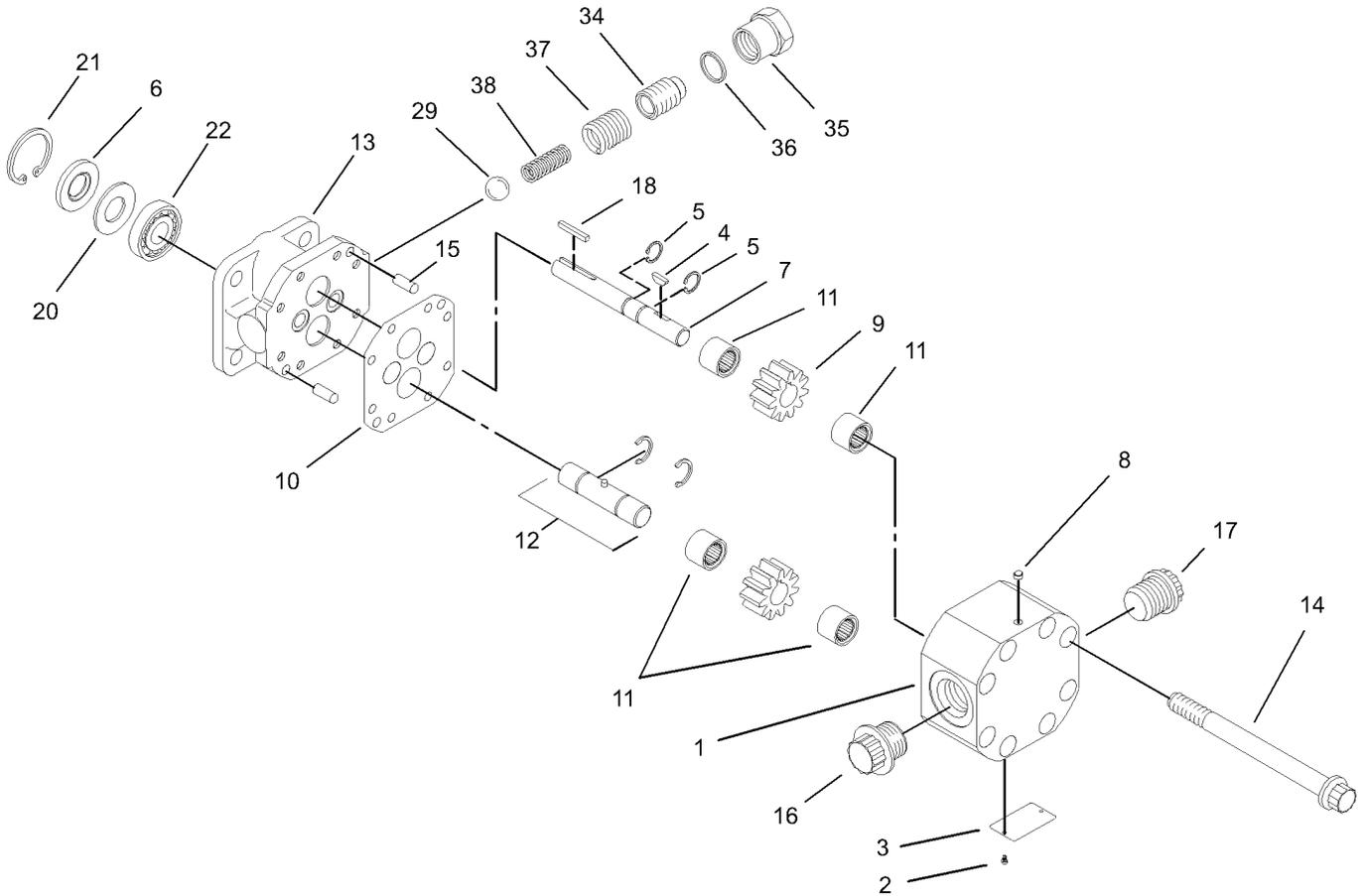

## Steering Pump Assembly No. 100-8302

Ref	Part No.	Qty.	Description
1		1	Housing
2		2	Screw
3		1	Plate-Name
4	100-8270	1	Key
5	106-6851	2	Ring-Retaining
6	100-8275	1	Seal
7	106-6852	1	Shaft-Drive
8	100-8269	1	Plug-Beta
9	106-6853	1	Gear
10	106-6854	1	Gasket Kit
11	106-6855	4	Bearing-Needle
12	106-6856	1	Shaft-Idler
13		1	Stator
14	100-8268	8	Screw
15	100-8265	2	Pin-Shear
16		1	Plug
17		1	Plug
18	92-3876	1	Key-Shaft
20	92-2186	1	Spacer
21	106-6857	1	Ring-Retaining
22	92-2191	1	Bearing-Ball
29	100-8273	1	Ball-Steel
34	100-8272	1	Screw
35	92-2184	1	Cap-Hex, Relief Valve

Ref	Part No.	Qty.	Description
36	92-2180	1	Gasket-Copper
37	92-3870	1	Spring
38	92-3871	1	Spring

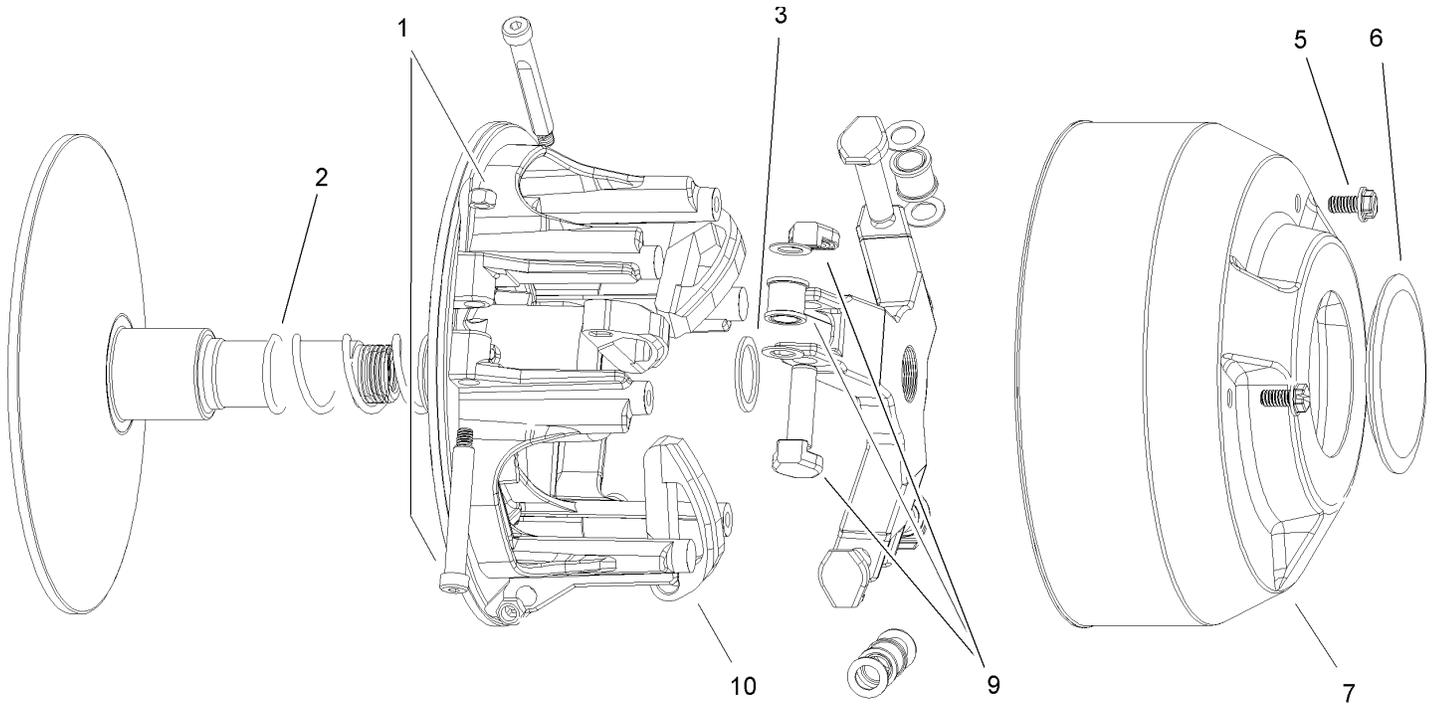

## Driver Clutch Assembly No. 100-8288

Ref	Part No.	Qty.	Description
1	104-4256	1	Pivot Bolt And Nut Kit
2	100-6921	1	Spring-White
3	104-1687	1	Spacer
5	3234-26	3	Screw
6	104-1690	1	Cap
7	104-1691	1	Cover
9	104-1697	1	Spider Roller Kit
10	100-6922	1	Arm-Cam

--	--	--	--

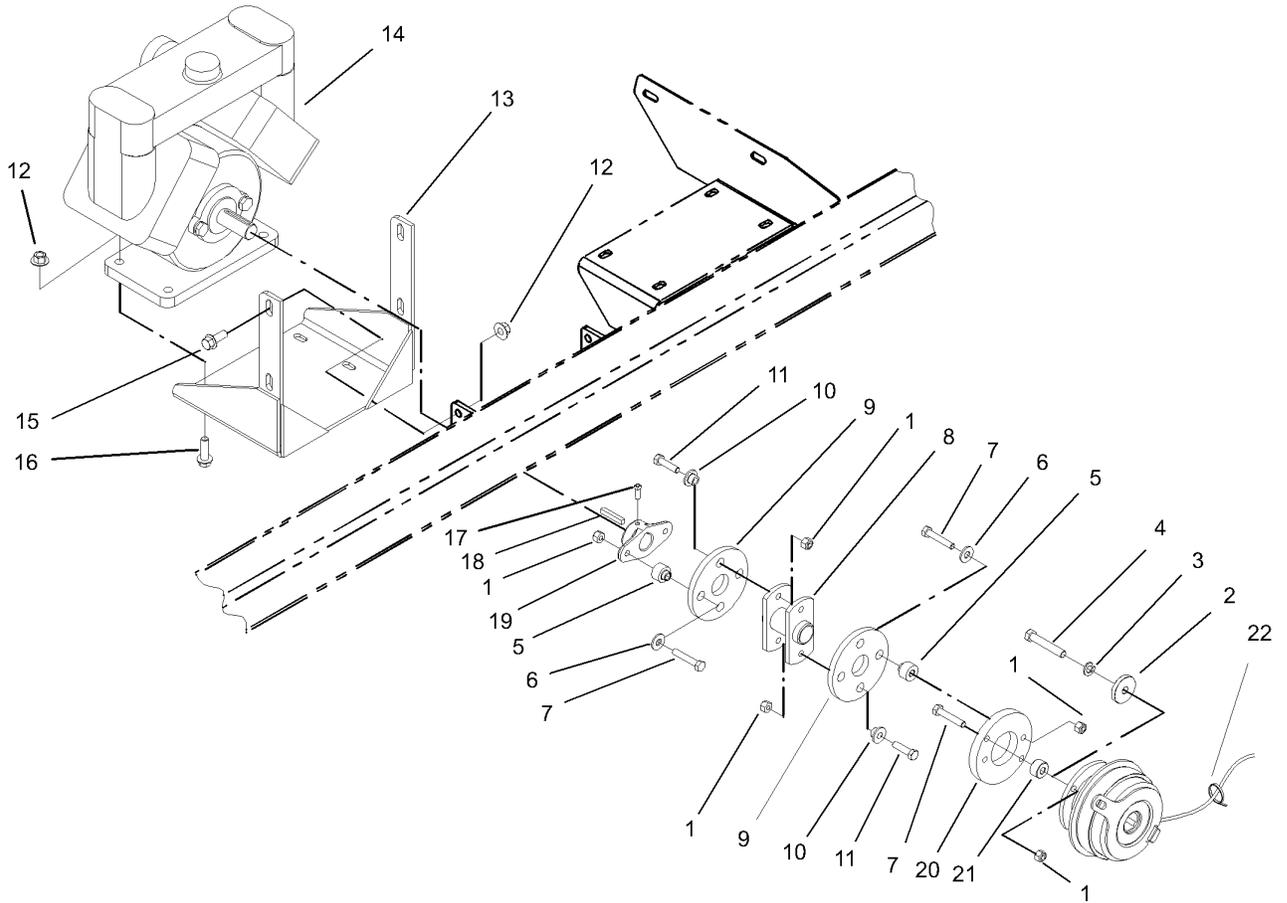

### Pump Installation Assembly

Ref	Part No.	Qty.	Description
1	3296-29	10	Nut-Lock, NI
2	100-8391	1	Retainer-Clutch, Electric
3	3253-5	1	Washer-Lock
4	3211-10	1	Screw-HH
5	27-6590	4	Spacer-Coupling, Rubber
6	3256-3	4	Washer-Flat
7	322-9	6	Screw-HH
8	80-6950-03	1	Coupler-Drive
9	100-8471	2	Coupling-Rubber
10	104-8774	4	Spacer-Coupling
11	322-6	4	Screw-HH
12	32128-43	8	Nut-Flange
13	100-8477-03	1	Pump Mounting Bracket ASM
14	106-5121	1	Pump
15	3234-11	4	Screw-HHF
16	3234-24	4	Screw-HHF
17	3241-5	2	Screw-Set
18	67-7490	1	Key-Square
19	93-2589	1	Hub-Pump
20	100-8435	1	Adapter-Clutch
21	104-8763	2	Spacer
22	3290-379	4	Tie-Cable

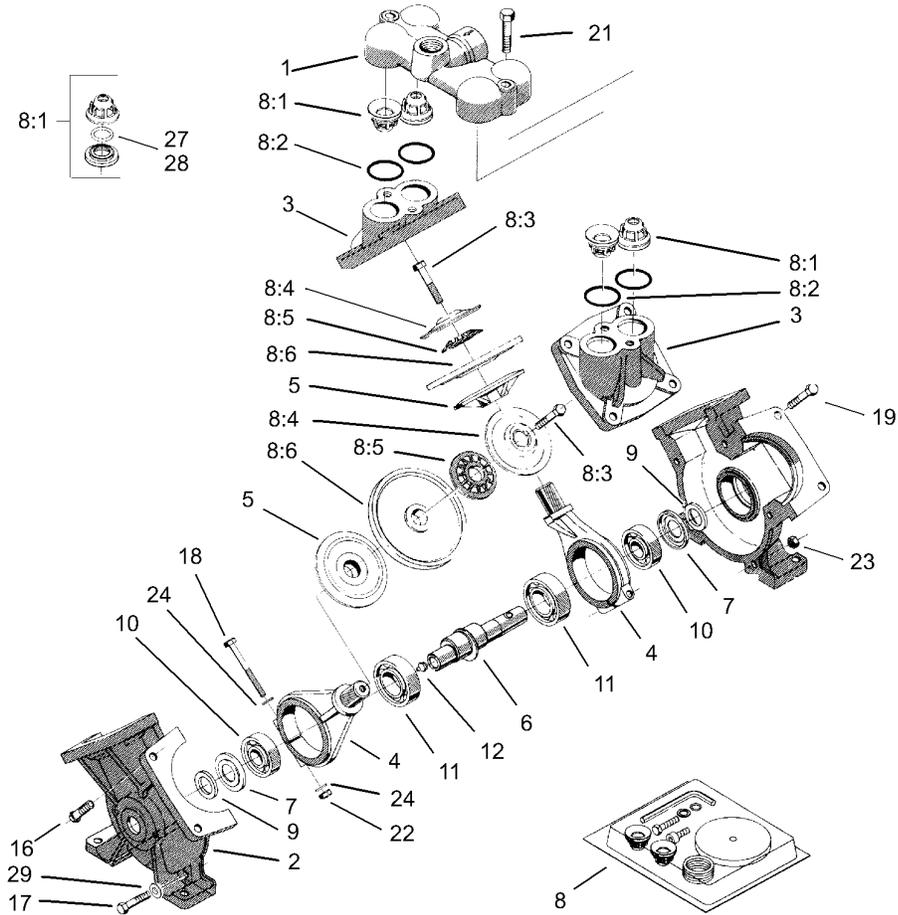
### Pump Assembly No. 106-5121

Ref	Part No.	Qty.	Description
1	106-5139	1	Cover-Valve
2	106-5140	2	Housing-Pump
3	106-5141	2	Cover-Diaphragm
4	106-5142	2	Rod-Connecting
5	100-8314	2	Disc-Back, Diaphragm
6	104-9052	1	Crankshaft-Keyed
7	100-8325	2	Plate-Dust
8	106-5150	1	Repair Kit
8:1	100-8307	4	Valve
8:2	100-6652	4	Gasket
8:3	106-5147	2	Bolt
8:4	100-8311	2	Washer
8:5	100-8312	2	Washer-Nylon
8:6	100-8313	2	Diaphragm
9	99-0868	2	Felt-Seal
10	100-8327	2	Bearing-Ball
11	100-8329	2	Bearing-Ball
12	99-0873	1	Fitting-Grease
16	106-5143	3	Bolt
17	106-5144	2	Bolt
18	106-5145	2	Bolt
19	106-5146	8	Bolt
21	106-5148	2	Bolt
22	100-8326	2	Nut-Hex

Ref	Part No.	Qty.	Description
23	106-5149	5	Nut
24	100-8316	4	Washer-Lock
27	100-8336	4	O-Ring
28	106-5138	4	O-Ring
29	106-5137	2	Washer

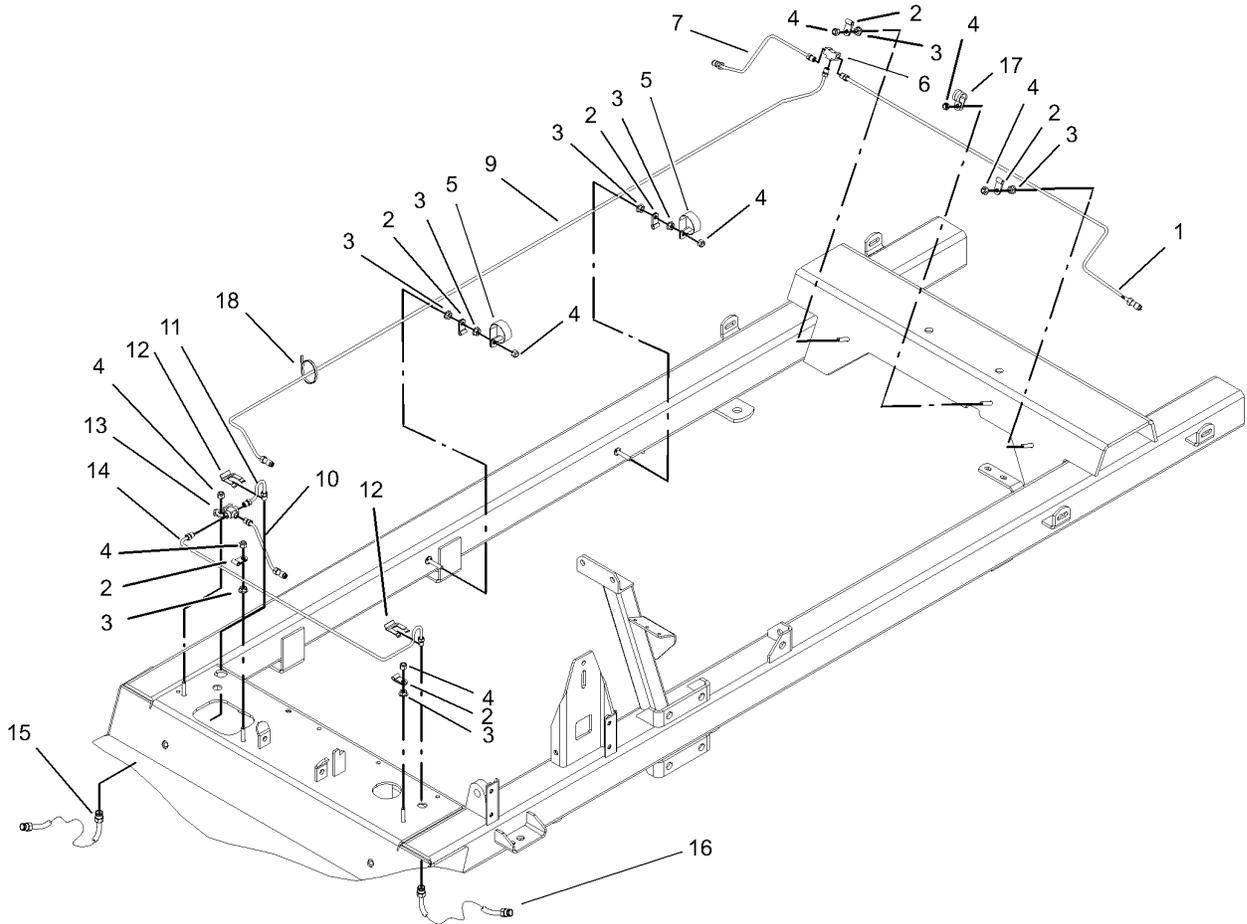

## Hydraulic Brake Line Assembly

Ref	Part No.	Qty.	Description
1	100-8511	1	Tube-Brake, Rear (LH)
2	2412-149	6	Clamp-Hose
3	32128-33	8	Nut-HF
4	3296-42	8	Nut-Lock, NI
5	2412-74	2	R-Clamp
6	98346	1	Fitting-Tee
7	100-8510	1	Tube-Brake, Rear (RH)
9	100-8509	1	Brake Tube ASM
10	100-8506	1	Brake Tube ASM
11	100-8508	1	Tube-Brake, Front (RH)
12	87-3580	2	Clip-Retainer
13	87-3560	1	Tee
14	100-8507	1	Tube-Brake, Front (LH)
15	100-8420	1	Hose-Brake, Front
16	100-8467	1	Hose-Brake, Front (LH)
17	2412-134	1	Clamp-R
18	3290-379	6	Tie-Cable

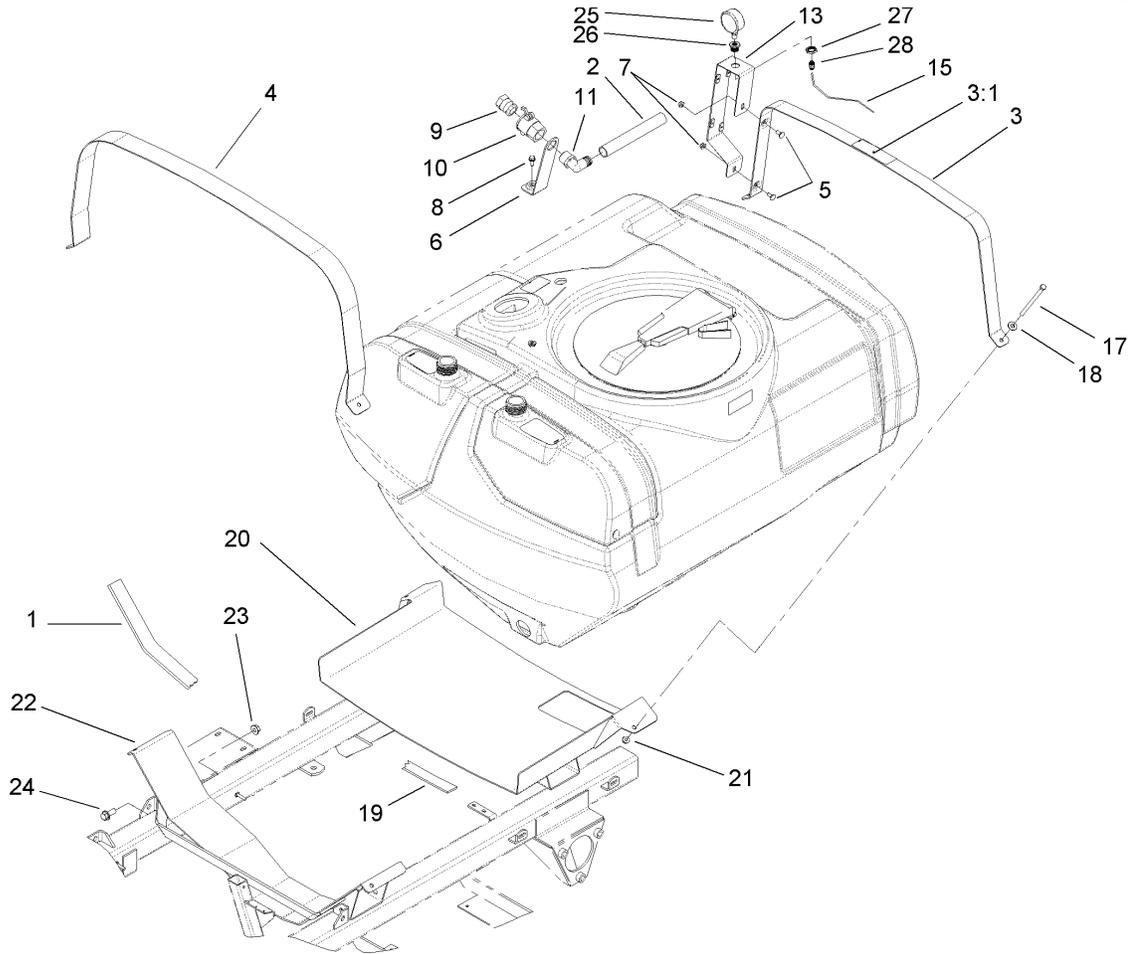

## Tank and Saddle Assembly

Ref	Part No.	Qty.	Description
1	100-8573	2	Foam-Saddle, Front
2	104-9075	1	Hose-Siphon, Anti
3	106-5048	1	Tank Band ASM
3:1	106-5016	1	Decal-Caution, Electric Shock
4	106-5063-03	1	Band-Tank, Front
5	3230-1	2	Bolt-CARR
6	100-6778-03	1	Bracket-Siphon, Anti
7	32128-20	2	Nut-HF
8	3234-5	1	Screw-HHF
9	41316	1	Adapter-Quick
10	100-6779	1	Coupling-Female
11	41140	1	Elbow
13	106-5176-03	1	Tee-Bracket, Mounting
15	104-8989	1	Tubing-Pressure
17	100-8528	4	Screw-HH
18	3256-4	4	Washer-Flat
19	100-8574	3	Foam-Saddle, Right Rear
20	100-8569-03	1	Rear Saddle ASM
21	104-8301	4	Nut-Flange, NI
22	100-8565-03	1	Front Saddle ASM
23	32128-49	4	Nut-HHF
24	3234-32	4	Screw-HHF
25	100-8576	1	Gauge-Pressure
26	100-8665	1	Reducer-Gauge, Pressure

Ref	Part No.	Qty.	Description
27	100-8666	1	Nut-Reducer
28	100-8667	1	Coupler-Reducer

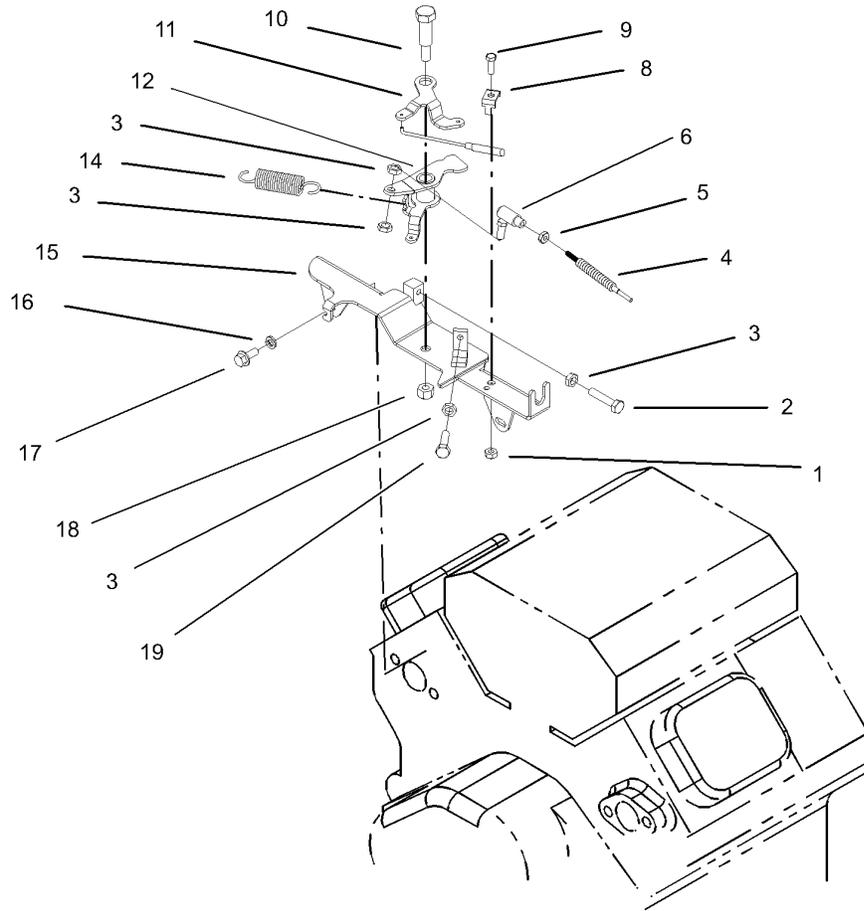

### Throttle Linkage Assembly

Ref	Part No.	Qty.	Description
1	3296-2	1	Nut-Lock, NI
2	329-7	1	Screw-HH
3	3220-1	4	Nut-Jam
4	100-8383	1	Cable-Accelerator
5	3219-14	1	Nut-Hex
6	100-8559	1	Ball Joint ASM
8	92-0477	1	Clamp-Cable
9	3290-134	1	Screw
10	7-0030	1	Screw-Shoulder, HH
11	87-7790	1	Lever-Choke
12	100-8558	1	Lever-Throttle
14	67-1450	1	Spring-Idler
15	100-8557	1	Lever-Throttle
16	48-8020	4	Washer-Spring
17	33103-016	4	Screw-HHF
18	3296-29	1	Nut-Lock, NI
19	329-6	1	Screw-HH

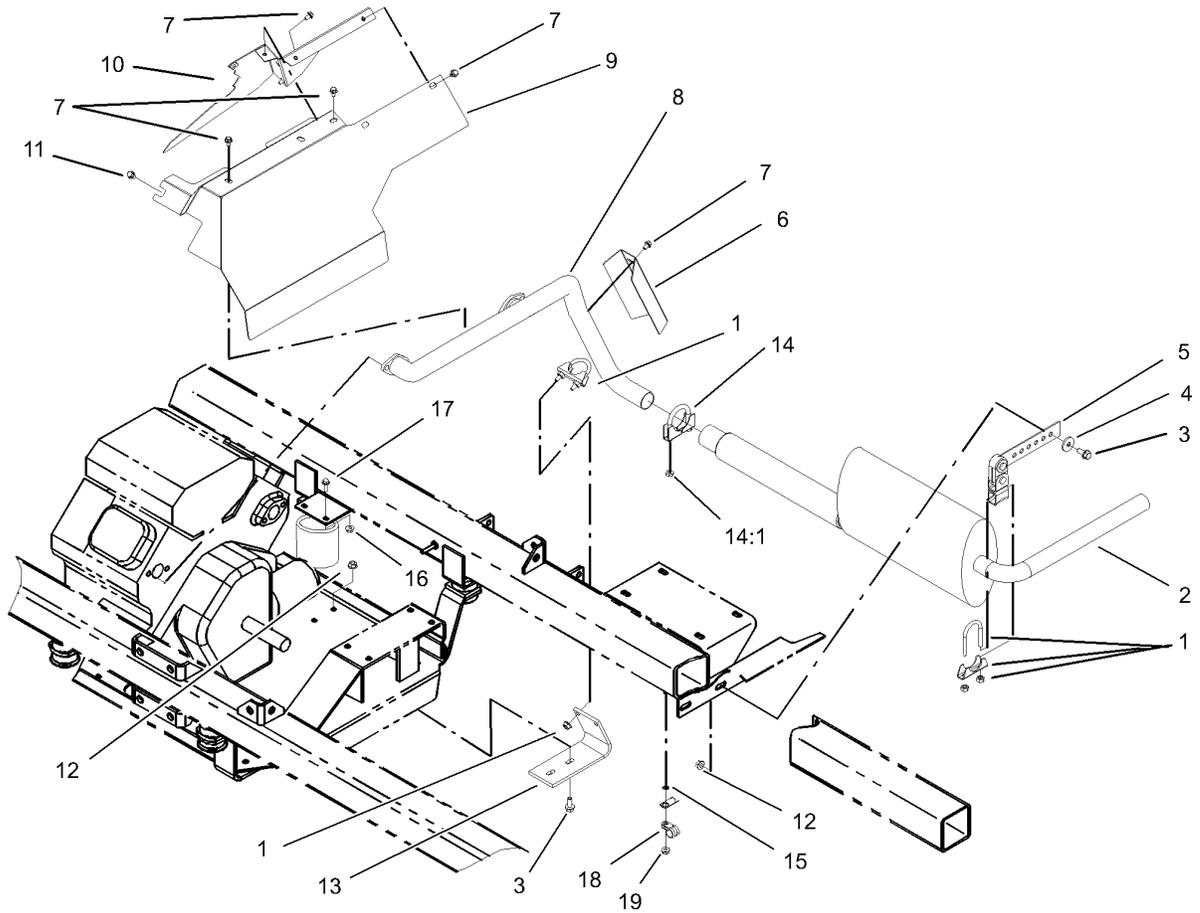

## Exhaust Assembly

Ref	Part No.	Qty.	Description
1	2112-11	2	Muffler Clamp ASM
2	100-8292	1	Muffler Tailpipe ASM
3	3234-5	4	Screw-HHF
4	356303	2	Washer
5	100-8526	1	Hanger-Muffler
6	100-8409-03	1	Shield-Exhaust, Lower
7	3234-26	10	Screw
8	100-8291	1	Header Pipe ASM
9	100-7028-03	1	Shield-Heat, Upper
10	100-7029-03	1	Shield-Heat, Middle
11	33103-012	1	Screw-HHF
12	32128-20	4	Nut-HF
13	100-8527	1	Support-Header
14	2112-9	1	Clamp
14:1	32128-20	2	Nut-HF
15	3255-7	1	Washer-Lock/EXT
16	32128-33	2	Nut-HF
17	3234-4	2	Screw-HHF
18	2412-134	1	Clamp-R
19	32128-33	1	Nut-HF

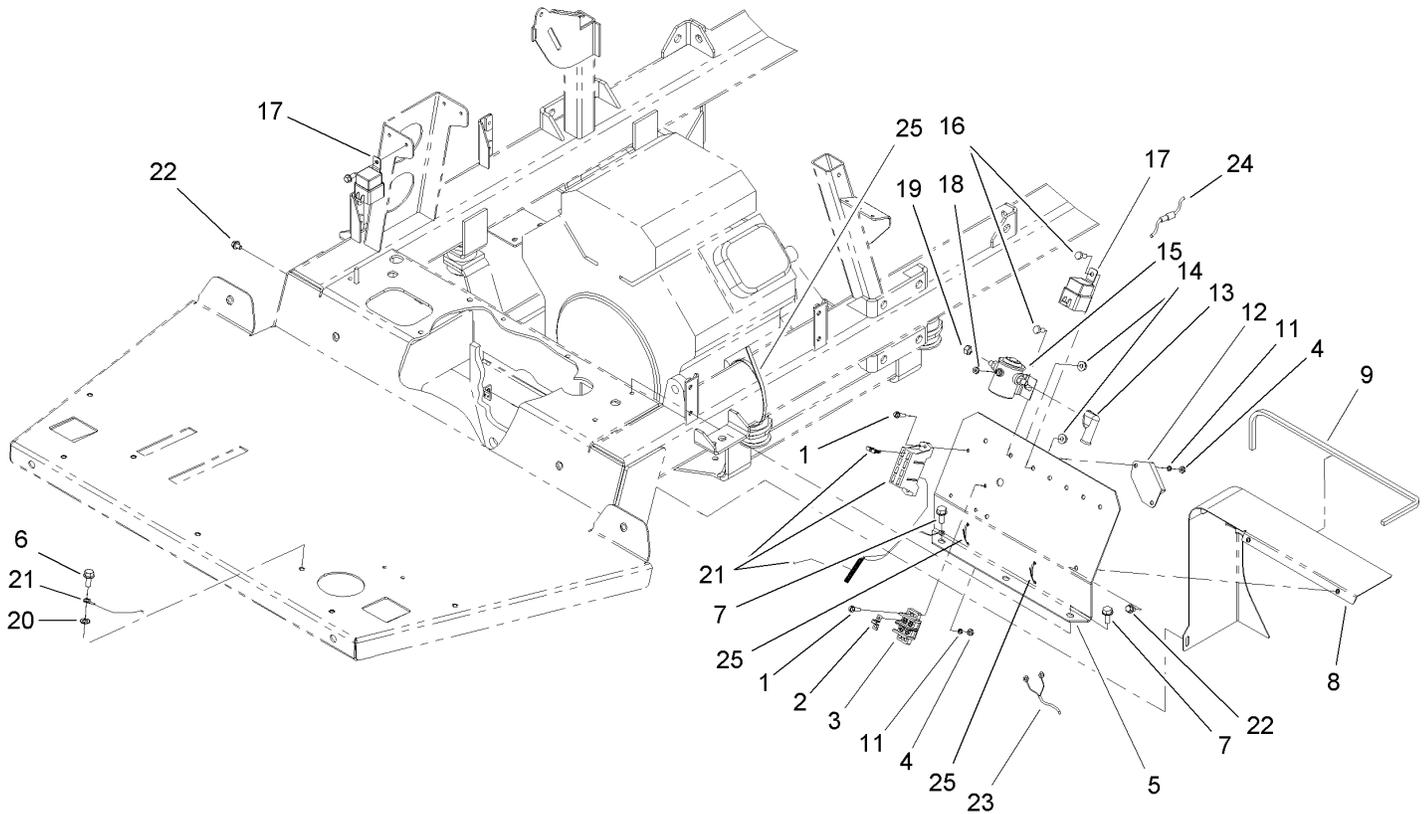
## Electrical Panel Assembly

Ref	Part No.	Qty.	Description
1	32105-13	4	Screw-HWH
2	42863	1	Strip-Jumper
3	42862	1	Block-Terminal, Ground
4	3217-26	4	Nut-Hex
5	100-8441-03	1	Panel-Electrical
6	3234-5	1	Screw-HHF
7	32144-70	3	Screw-HWHTF
8	100-7025-03	1	Shield-Heat, Front
9	100-7027	1	Trim
11	3253-17	4	Washer-Lock
12	99-3703	1	Module-Cruise
13	92-0034	3	Boot-Terminal
14	32128-33	7	Nut-HF
15	94-7079	1	Solenoid-Accessory
16	321-3	7	Screw-HH
17	70-1480	6	Relay
18	3219-14	1	Nut-Hex
19	3219-2	2	Nut-Hex
20	3255-8	2	Washer-Lock
21	106-5114	1	Harness-Wire, Main Vehicle
22	3234-26	3	Screw
23	107-8600	1	Harness-Spray System
①23:1	100-4918	2	Diode
24	107-8602	3	Holder-Fuse

Ref	Part No.	Qty.	Description
①24:1	94-6710	1	Fuse-Blade, 2 Amp
25	3290-379	6	Tie-Cable

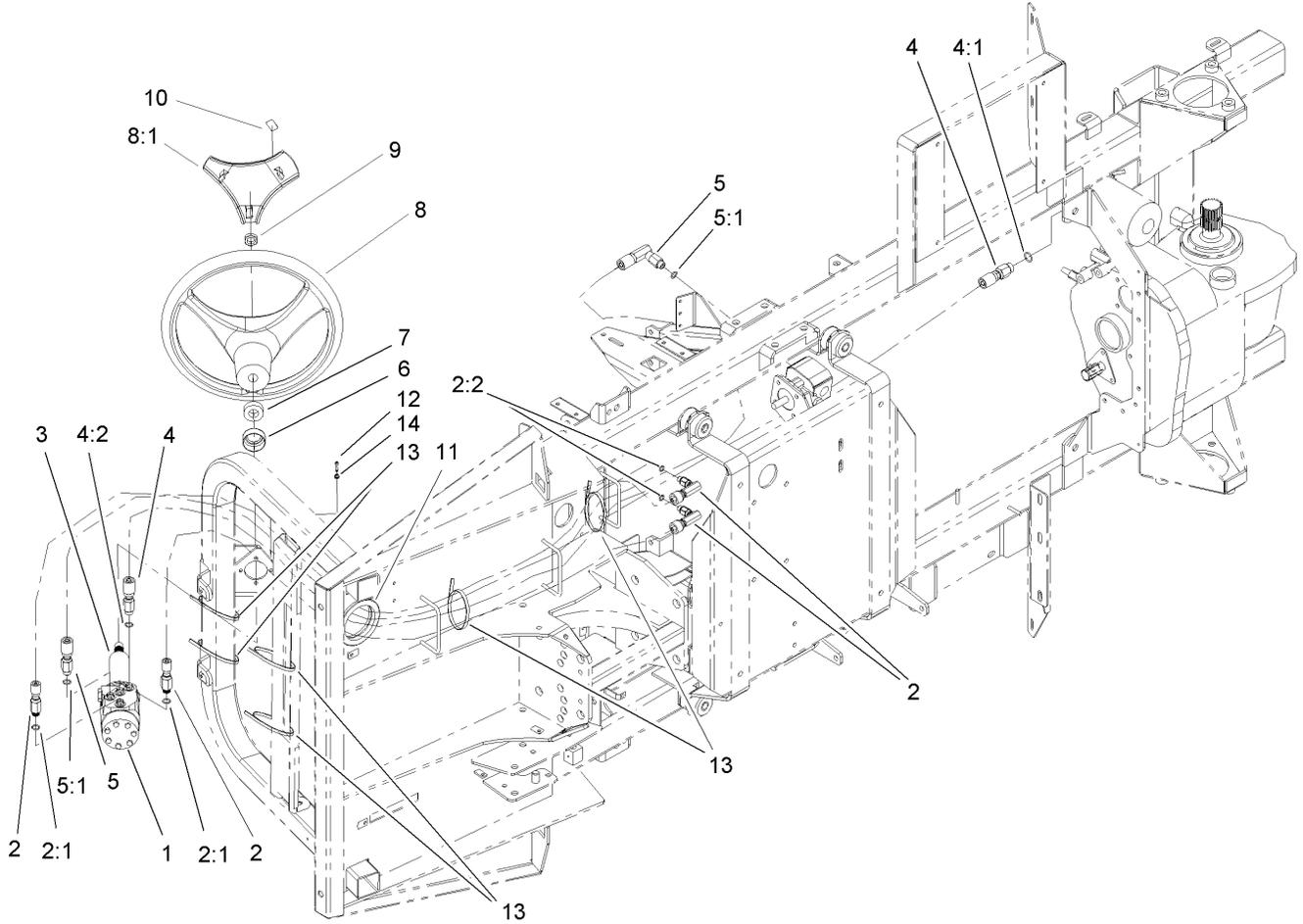

## Hydraulic Hose Routing Assembly

Ref	Part No.	Qty.	Description
1	92-3502	1	Steering Control ASM
2	100-8252	2	Hose ASM
2:1	237-78	1	O-Ring
2:2	237-42	1	O-Ring
3	94-8792	1	Column-Steering
4	100-8253	1	Hose ASM
4:1	237-42	1	O-Ring
4:2	237-79	1	O-Ring
5	100-8251	1	Hose ASM
5:1	237-42	2	O-Ring
6	93-5439	1	Seal-Steering
7	21-9260	1	Cover-Dust
8	98-1471	1	Wheel-Steering
8:1	98-1468	1	Cover-Wheel, Steering
9	92-3513	1	Nut
10	98-1459	1	Decal
11	237-102	1	Grommet
12	33113-020	4	Screw-HH
13	3290-379	14	Tie-Cable
14	3253-18	4	Washer-Lock

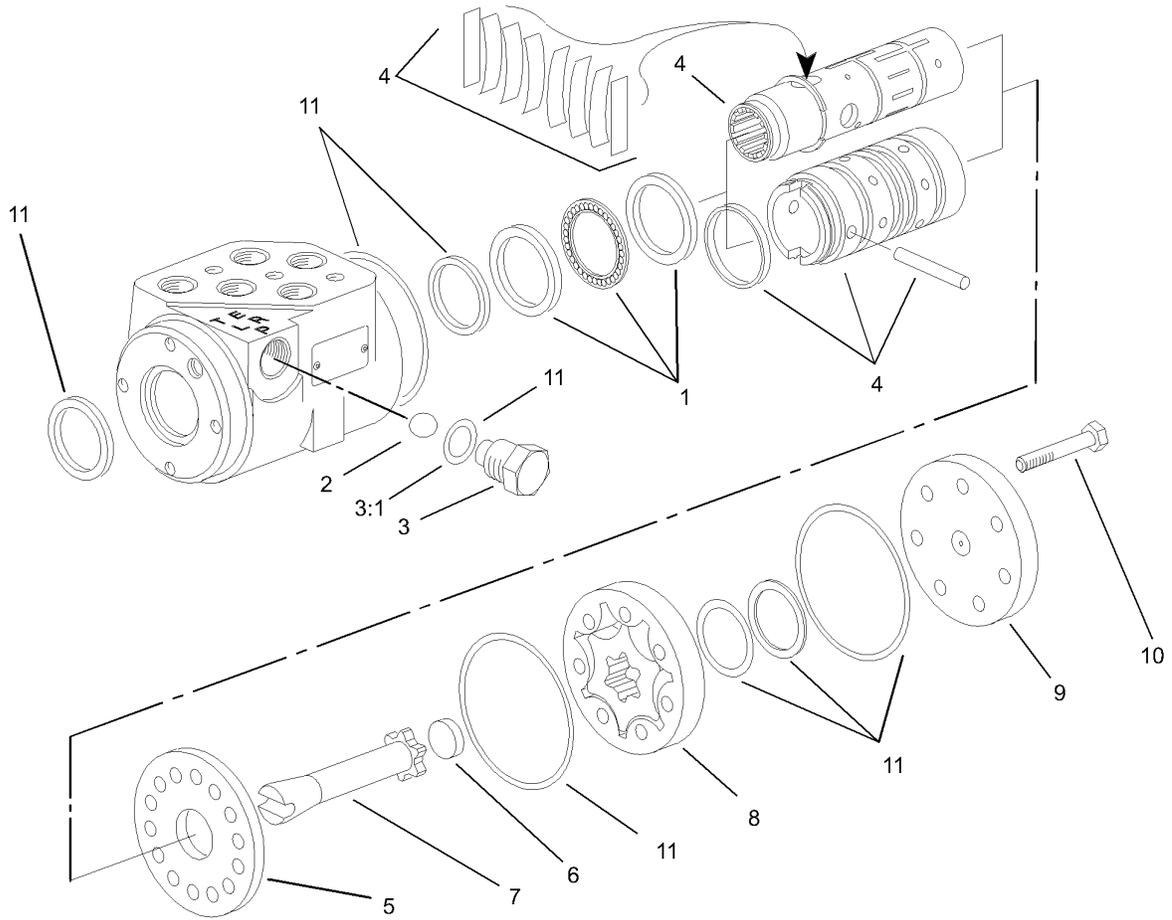
## Steering Control Assembly No. 92-3502

Ref	Part No.	Qty.	Description
1	94-4096	1	Bearing Kit
2	92-3842	1	Ball
3	92-3841	1	Plug ASM
3:1		1	Seal-Dust
4	94-4095	1	Centering Spring Kit
5	92-3843	1	Plate-Wear
6	92-3845	1	Spacer
7	92-3844	1	Drive
8	92-3846	1	Gerotor
9	92-3847	1	Cap-End
10	92-3848	7	Capscrew
11	92-3849	1	Seal Kit

## Sprayer Component Assembly No.1

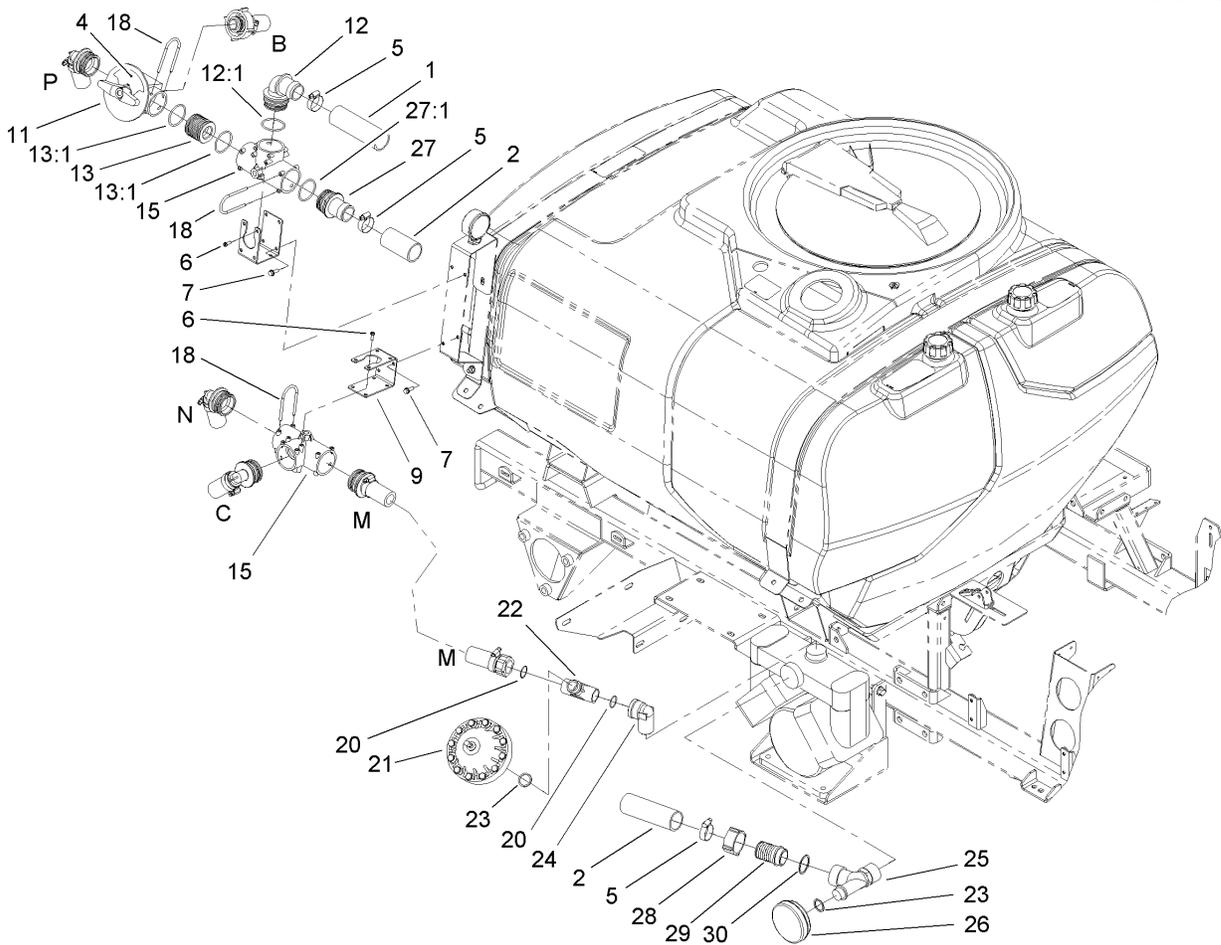
Ref	Part No.	Qty.	Description
1	107-8627	1	Hose-Suction
2	100-8484	1	Hose-Suction
4	100-8577	1	Decal-Agitate Valve
5	41327	4	Clamp-Hose
6	32144-32	8	Screw
7	3234-4	4	Screw-HHF
9	100-8478	2	Bracket-Tee
11	100-8673	1	Agitation Valve ASM
12	106-4946	1	Hosebarb-90 DEG
12:1	100-8637	1	O-Ring
13	106-4947	1	Connector
13:1	100-8637	2	O-Ring
15	100-6704	2	Tee
18	100-8635	8	Fork
20	100-6655	2	Gasket
21	100-6662	1	Damper-Pressure
22	100-8699	1	Tee
23	100-6656	2	O-Ring
24	100-8698	1	Elbow
25	100-8681	1	Tee
26	100-6660	1	Suction Damper ASM
27	106-4936	1	Hosebarb
27:1	100-8637	1	O-Ring
28	100-8678	1	Nut

Ref	Part No.	Qty.	Description
29	100-8679	1	Hosebarb
30	100-8680	1	Seal

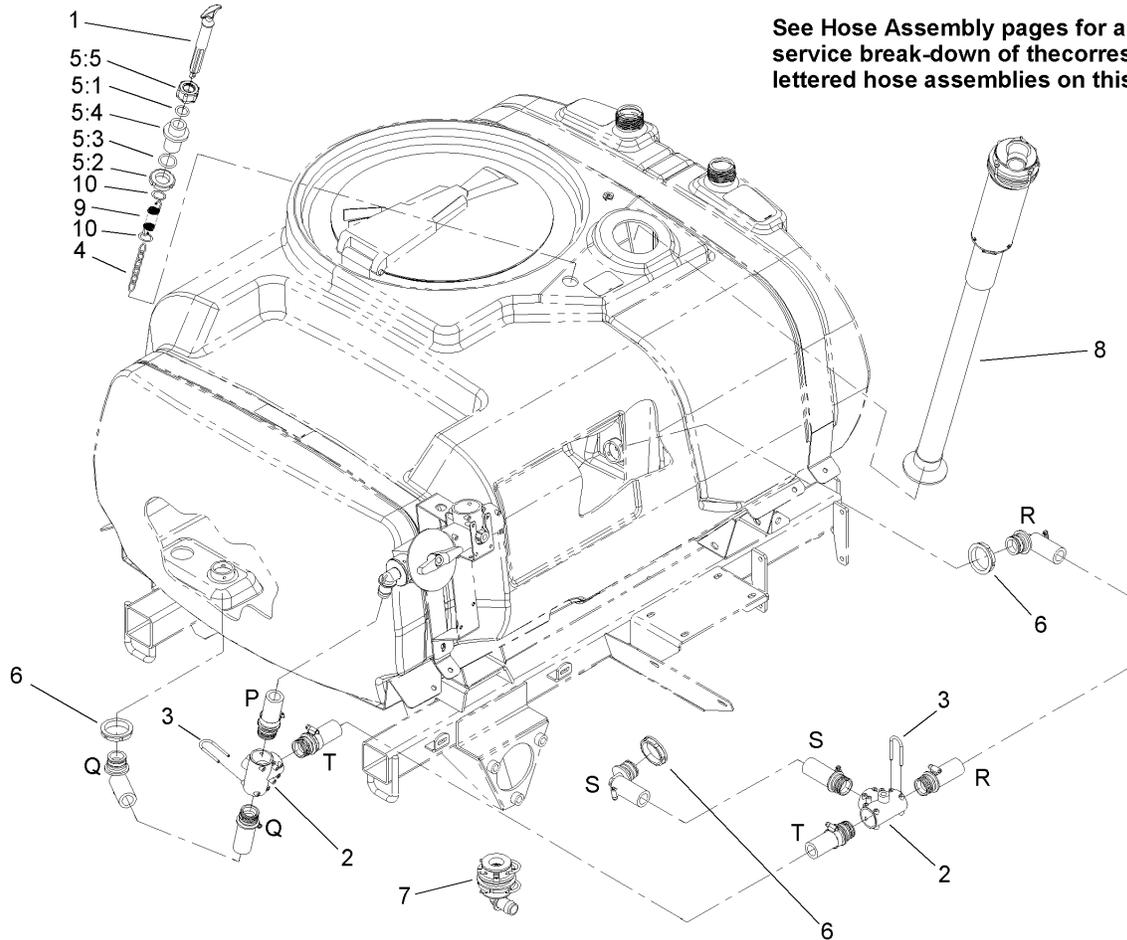

## Sprayer Component Assembly No. 2

Ref	Part No.	Qty.	Description
1	106-1347	1	Handle-Drain
2	104-9041	2	Tee
3	100-6708	6	Fork
4	106-4858	1	32 Inch Chain ASM
5		1	Upper Tank Drain Bulkhead ASM
5:1	100-6643	1	O-Ring
5:2	99-0758	1	Nut
5:3	100-6658	1	Gasket
5:4	106-1240	1	Bulkhead
5:5	106-1241	1	Nut-Special
6	100-6713	3	Nut-Bulkhead
7		1	Tank Drain ASM
8		1	Top Mounted Suction ASM
9	106-1391	1	Spring-Extension
10	106-1392	2	Ring-Retaining, Spiral (EXT)

Ref	Part No.	Qty.	Description



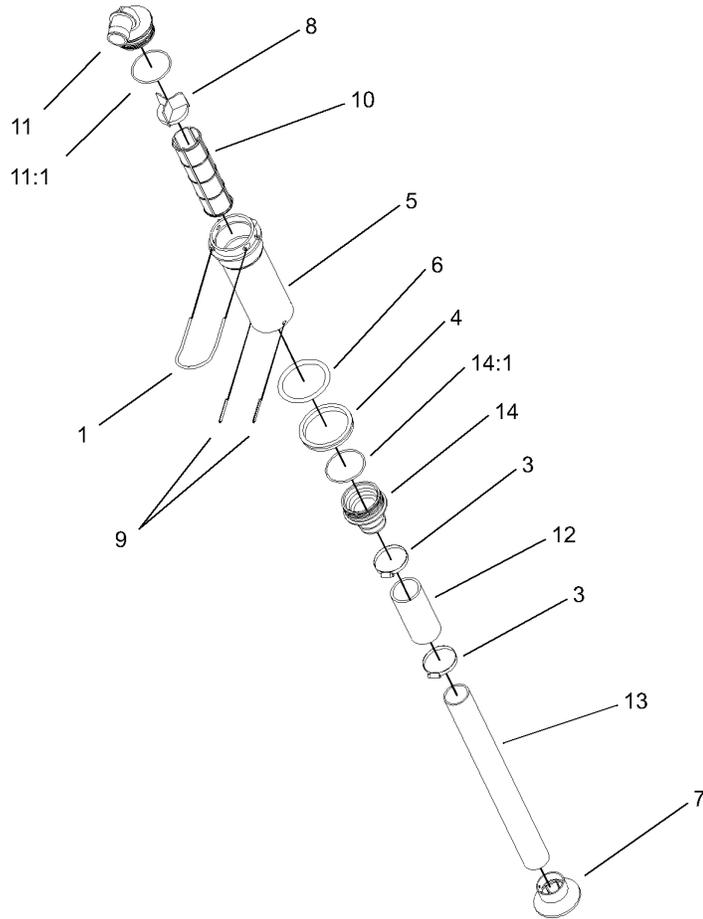

### Top Mounted Suction Assembly

Ref	Part No.	Qty.	Description
1	100-8636	1	Fork-Special
3	26392	2	Clamp-Hose
4	100-8647	1	Nut-Bulkhead
5	100-8643	1	Housing-Filter
6	100-8646	1	Gasket-Bulkhead
7	100-6714	1	Foot-Tube, Suction
8	100-8641	1	Vane-Screen
9	100-8644	2	Pin-Expansion
10	100-6991	1	Element-Filter, Green
10	100-6992	1	Element-Filter, Red
10	100-8642	1	Screen-Suction, Mesh 50
11	106-4952	1	Hosebarb-90 DEG
11:1	100-6989	1	O-Ring
12	100-8649	1	Hose-Suction
13	107-8625	1	Tube-Suction
14	106-4942	1	Hosebarb-Straight
14:1	100-8640	1	O-Ring

--	--	--	--





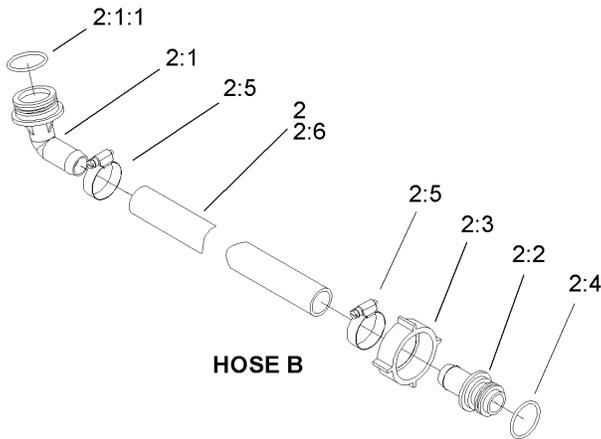
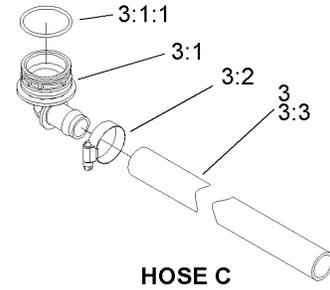
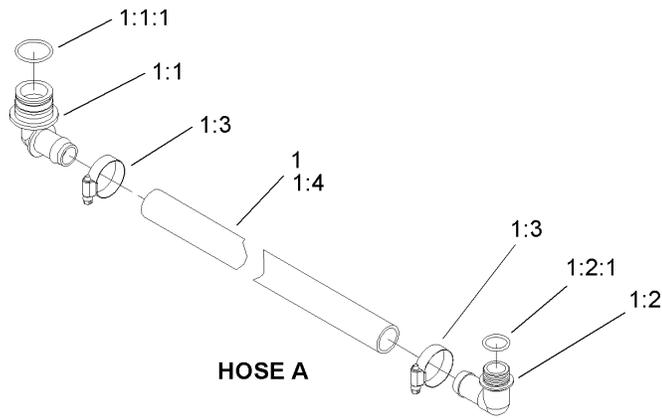

## Hose Assemblies No. 1

Ref	Part No.	Qty.	Description
②1		1	Boom Bypass Hose ASM
1:1	106-4945	1	Elbow
1:1:1	100-6712	1	O-Ring
1:2	106-4948	1	Hose Barb ASM
1:2:1	100-6882	1	O-Ring
1:3	2412-3	2	Clamp-Hose
1:4	107-8628	1	Hose-Bypass, Boom
②2		1	Agitation Supply Hose ASM
2:1	106-4950	1	Hose Barb ASM
2:1:1	100-8671	1	O-Ring
2:2	100-8670	1	Hosebarb
2:3	100-8669	1	Nut
2:4	100-8671	1	O-Ring
2:5	2412-3	2	Clamp-Hose
2:6	104-8711	1	Hose
②3		1	Tee Controls Hose ASM
3:1	106-4933	1	Hosebarb ASM
3:1:1	100-8637	1	O-Ring
3:2	2412-3	1	Clamp-Hose
3:3	104-8713	1	Hose

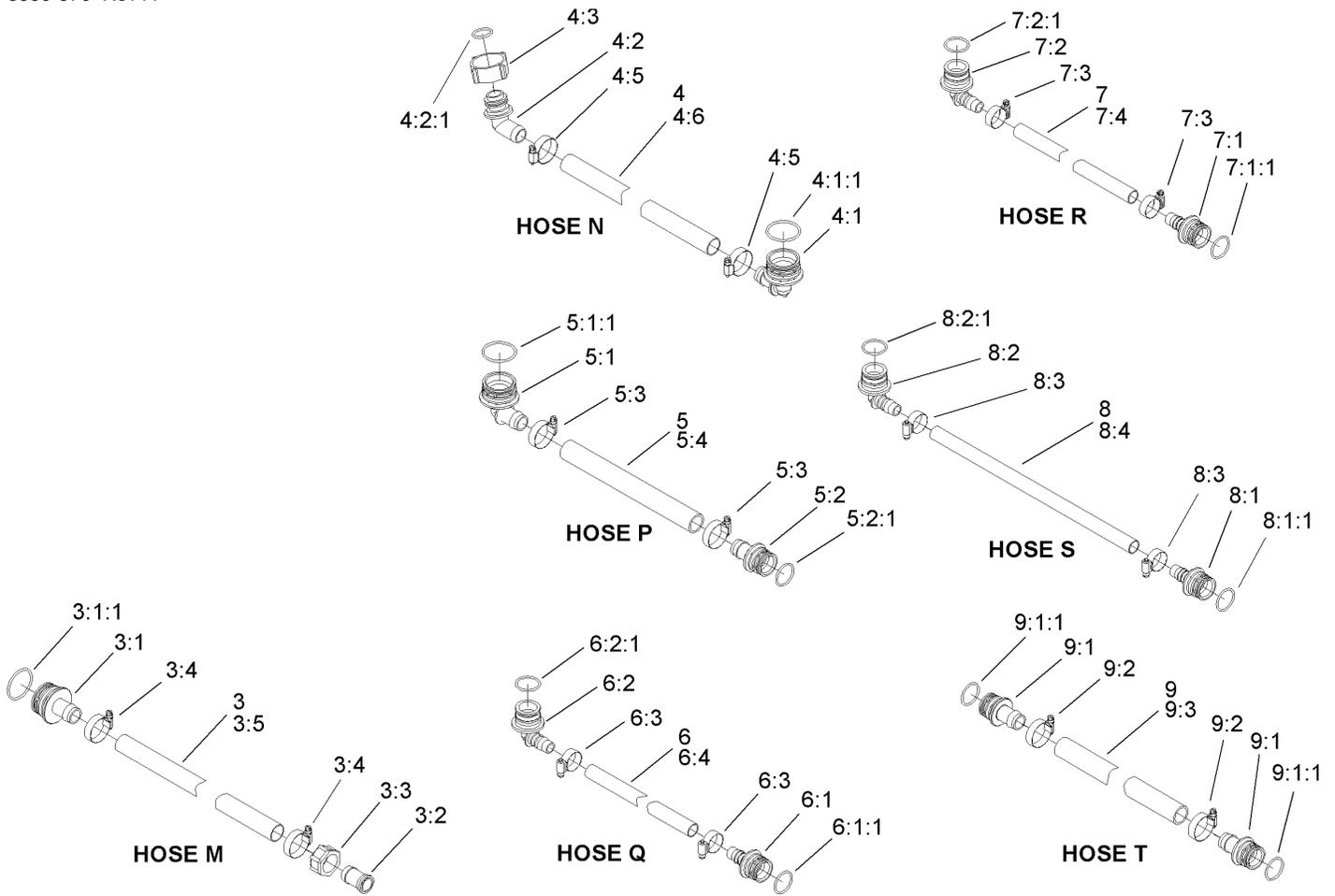

## Hose Assemblies No. 2

Ref	Part No.	Qty.	Description
②3		1	Manifold Tee Hose ASM
3:1	106-4932	1	Hosebarb-Straight
3:1:1	100-8637	1	O-Ring
3:2	99-0781	1	Hosebarb
3:3	99-0769	1	Nut
3:4	2412-3	2	Clamp-Hose
3:5	104-8712	1	Hose
②4		1	Relief Valve Hose ASM
4:1	106-4933	1	Hosebarb ASM
4:1:1	100-8637	1	O-Ring
4:2	106-4949	1	Hosebarb
4:2:1	100-6646	1	O-Ring
4:3	100-8678	1	Nut
4:5	2412-3	2	Clamp-Hose
4:6	104-8710	1	Hose
②5		1	Agitation Valve Hose ASM
5:1	106-4933	1	Hosebarb ASM
5:1:1	100-8637	1	O-Ring
5:2	106-4935	1	Hosebarb ASM
5:2:1	100-6712	1	O-Ring
5:3	2412-3	2	Clamp-Hose
5:4	104-8908	1	Hose-Bypass
②6		1	Rear Agitation Hose ASM
6:1	106-4939	1	Hosebarb-Straight

Ref	Part No.	Qty.	Description
6:1:1	100-6712	1	O-Ring
6:2	106-4940	1	Hosebarb-90 DEG
6:2:1	100-6712	1	O-Ring
6:3	2412-129	2	Clamp-Hose
6:4	104-9043	1	Hose-Agitation, Rear
②7		1	Front Agitation Hose ASM
7:1	106-4939	1	Hosebarb-Straight
7:1:1	100-6712	1	O-Ring
7:2	106-4940	1	Hosebarb-90 DEG
7:2:1	100-6712	1	O-Ring
7:3	2412-129	2	Clamp-Hose
7:4	104-8706	1	Hose
②8		1	Middle Agitation Hose ASM
8:1	106-4939	1	Hosebarb-Straight
8:1:1	100-6712	1	O-Ring
8:2	106-4940	1	Hosebarb-90 DEG
8:2:1	100-6712	1	O-Ring
8:3	2412-129	2	Clamp-Hose
8:4	104-8704	1	Hose
②9		1	Agitation Tee Hose ASM
9:1	106-4935	2	Hosebarb ASM
9:1:1	100-6712	1	O-Ring
9:2	2412-3	2	Clamp-Hose
9:3	104-9039	1	Hose-Tee, Agitation

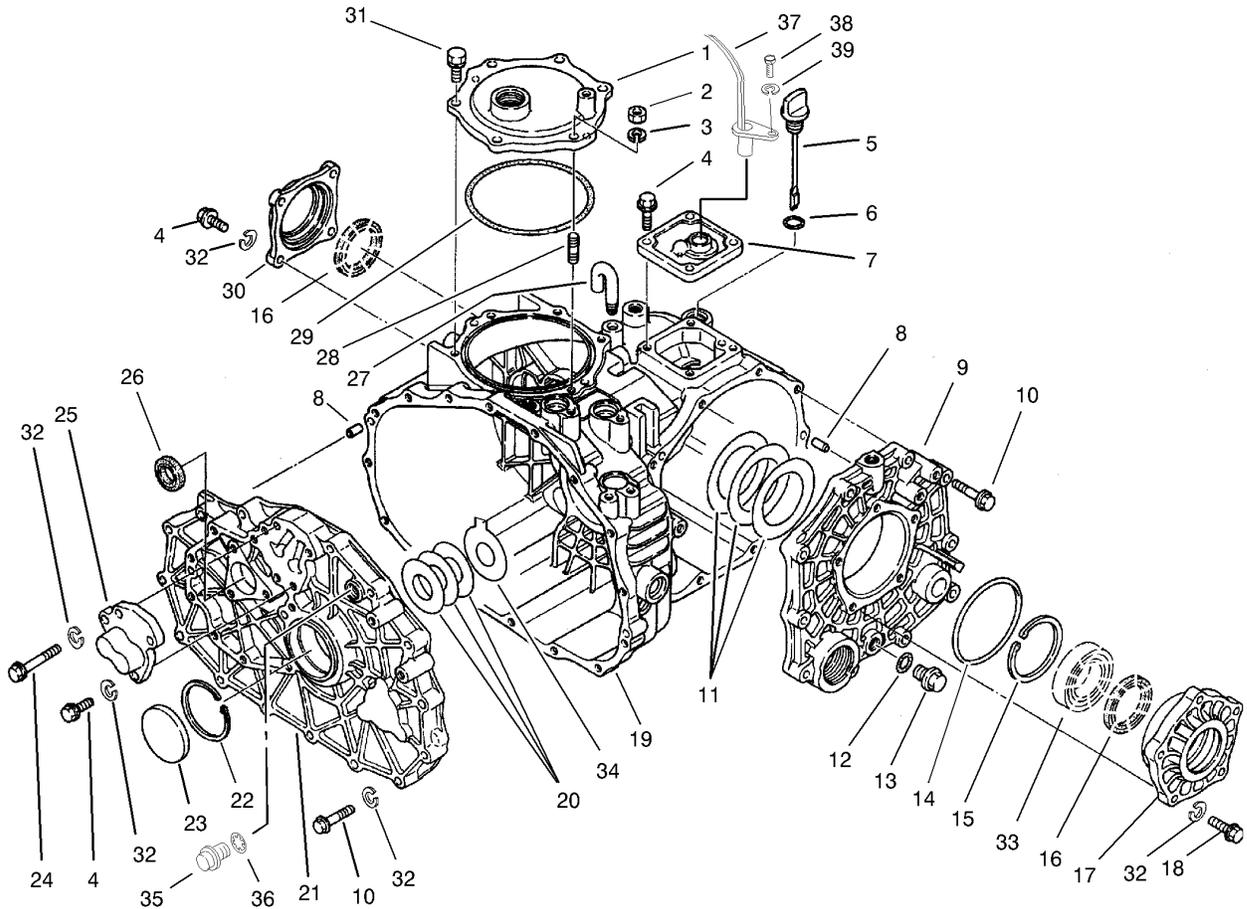

## Transaxle Case Assembly Transaxle Assembly No. 104-9078

Ref	Part No.	Qty.	Description
1	100-8595	1	Cover-PTO
2	48-7930	1	Nut
3	92-0762	1	Washer-Spring
4	33114-025	11	Screw-HH
5	92-0662	1	Cap-Oil
6	92-0788	1	O-Ring
7	92-0810	1	Cover-Upper, Sensor
8	92-0765	4	Pin-Parallel
9	92-0653	1	Cover-Side
10	33114-040	25	Screw-HH
11	92-0809	1	Set-Shim
12	92-0787	1	O-Ring
13	92-0773	1	Plug-Drain
14	92-0789	1	O-Ring
15	92-0760	1	Ring-Snap
16	92-0793	2	Seal-Oil
17	92-0654	1	Carrier-Differential
18	48-7730	5	Screw-HH
19	92-0651	1	Case-Transmission
20	100-4460	1	Shim-Set
21	100-4461	1	Plate-Center
22	92-0759	1	Ring-Snap
23	92-0807	1	Cap-Sealing
24	48-7560	1	Bolt-HH

Ref	Part No.	Qty.	Description
25	92-0706	1	Shaft-Fork
26	92-0791	1	Seal-Oil
27	92-0743	1	Breather-Air
28	92-0804	1	Stud
29	92-0790	1	O-Ring
30	92-0655	1	Cover-Seal, Axle
31	92-0796	5	Bolt
32	3253-4	42	Washer-Lock
33	92-0775	2	Bearing
34	100-4465	1	Shim (W/Tab)
35	100-6924	1	Plug
36	100-6925	1	Packing
37	85-4350	1	Sensor-Gear tooth
38	48-7610	1	Screw
39	48-8020	1	Washer-Spring
●99	100-6928	1	Bolt
●99	100-8594	1	Cover-Shaft, Input

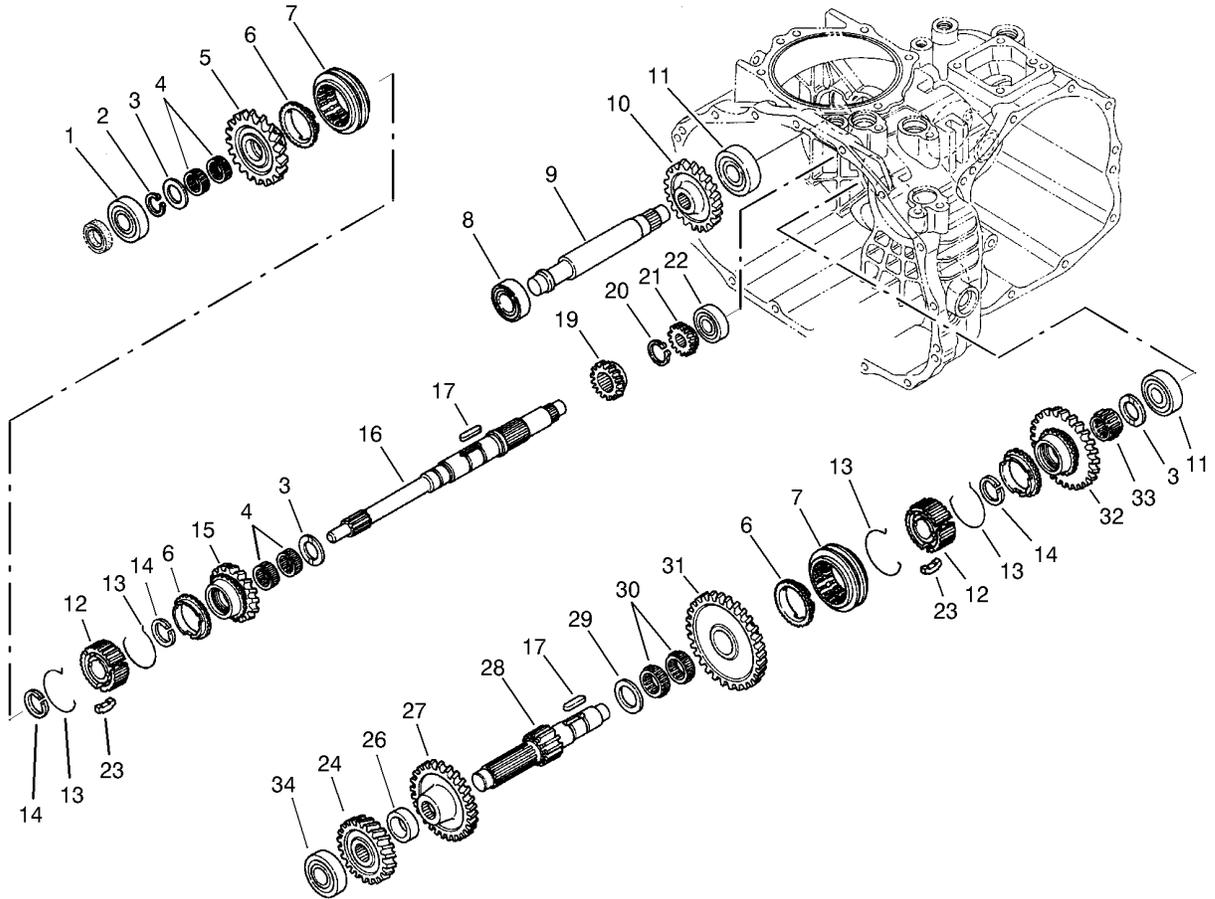

## Transaxle Gear Shaft Assembly Transaxle Assembly No. 104-9078

Ref	Part No.	Qty.	Description
1	251-8	1	Bearing-Ball
2	92-0753	1	Ring-Snap
3	92-0740	3	Washer-Thrust
4	92-0781	4	Bearing-Needle
5	100-8597	1	Gear-Main, 36 Tooth
6	92-0667	3	Ring-Synchro
7	92-0668	2	Shifter-Synchro
8	251-346	2	Bearing-Ball
9	100-8602	1	Shaft-Idler, Reverse
10	92-0684	1	Gear-Reverse, 33 Tooth
11	92-0778	2	Bearing
12	92-0664	2	Hub-Synchro
13	92-0666	4	Spring-Synchro
14	92-0763	3	Ring-Snap
15	100-8598	1	Gear-Main, 20 Tooth
16	100-8596	1	Shaft-Main
17	92-0772	2	Key
19	92-0671	1	Gear-Main, 22 Tooth
20	92-0754	1	Ring-Snap
21	92-0673	1	Gear-Main, 14 Tooth
22	92-0650	1	Bearing
23	92-0665	6	Key-Synchro
24	92-0676	1	Gear-Reduction, 32 Tooth
26	100-8601	1	Collar

Ref	Part No.	Qty.	Description
27	92-0819	1	Gear-Reduction, 40 Tooth
28	92-0674	1	Shaft-Reduction
29	92-0682	1	Washer-Thrust
30	92-0681	2	Bearing-Needle
31	100-8599	1	Gear-Red, 25 Tooth
32	100-8600	1	Gear-Red, 47 Tooth
33	92-0782	1	Bearing-Needle
34	105-7985	1	Bearing

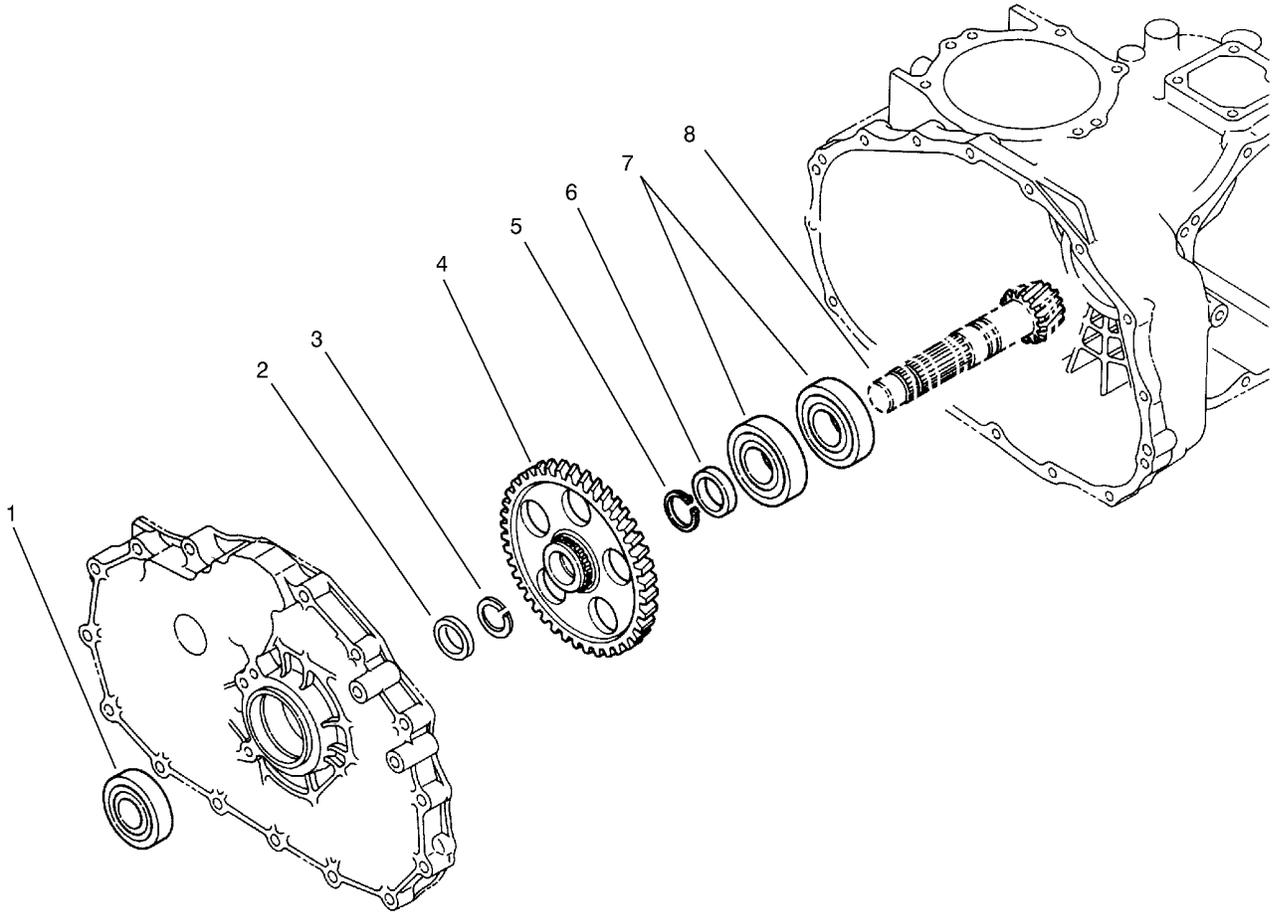

## Countershaft Assembly Transaxle Assembly No. 104-9078

Ref	Part No.	Qty.	Description
1	92-0712	1	Bearing-Ball
2	92-0716	1	Collar
3	92-0764	1	Ring-Snap
4	100-8603	1	Gear-Count
5	92-0755	1	Ring-Snap
6	92-0713	1	Collar
7	92-0714	2	Bearing
8	92-0710	1	Gear-Ring





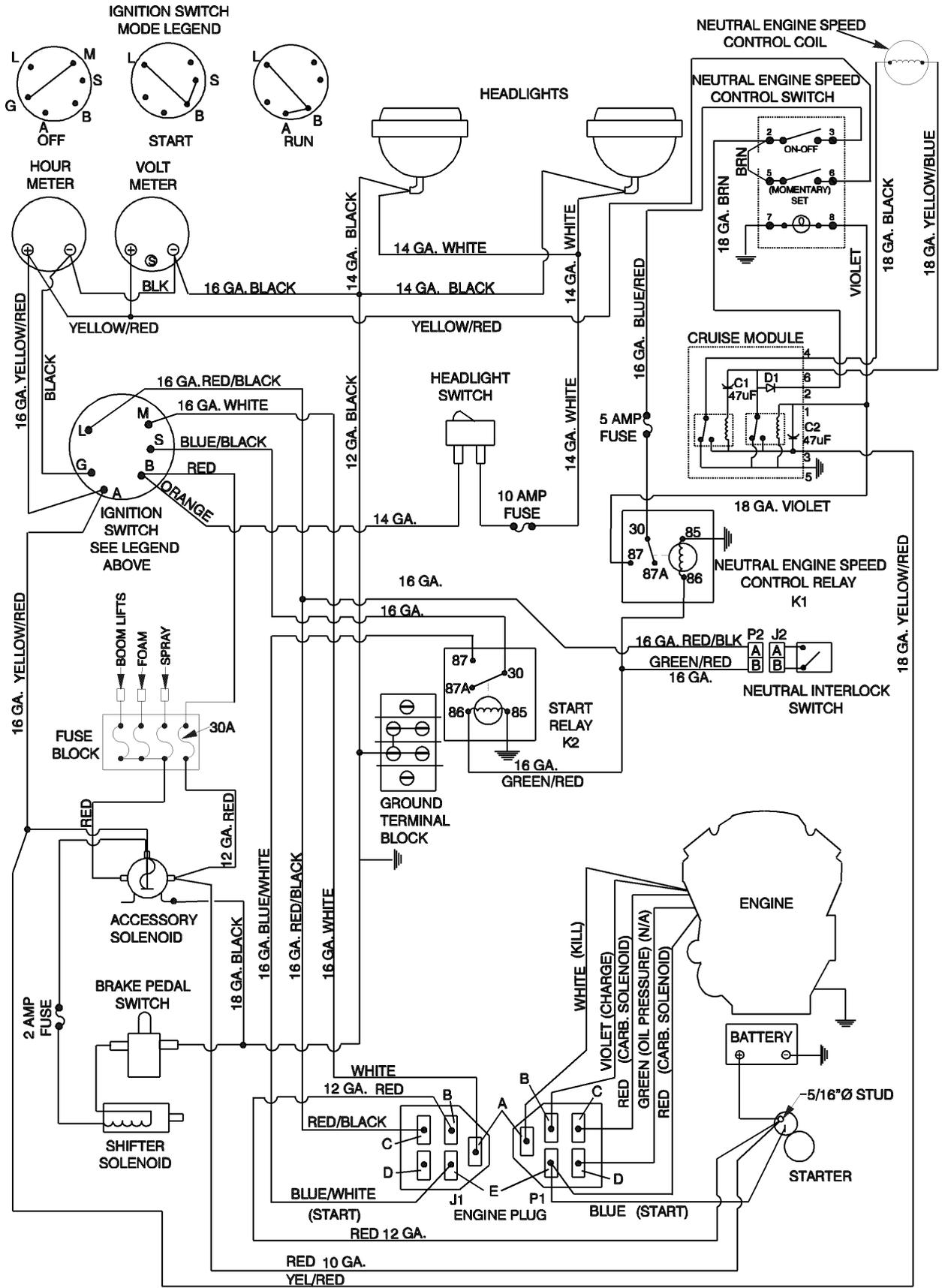

# Vehicle Electrical Schematic

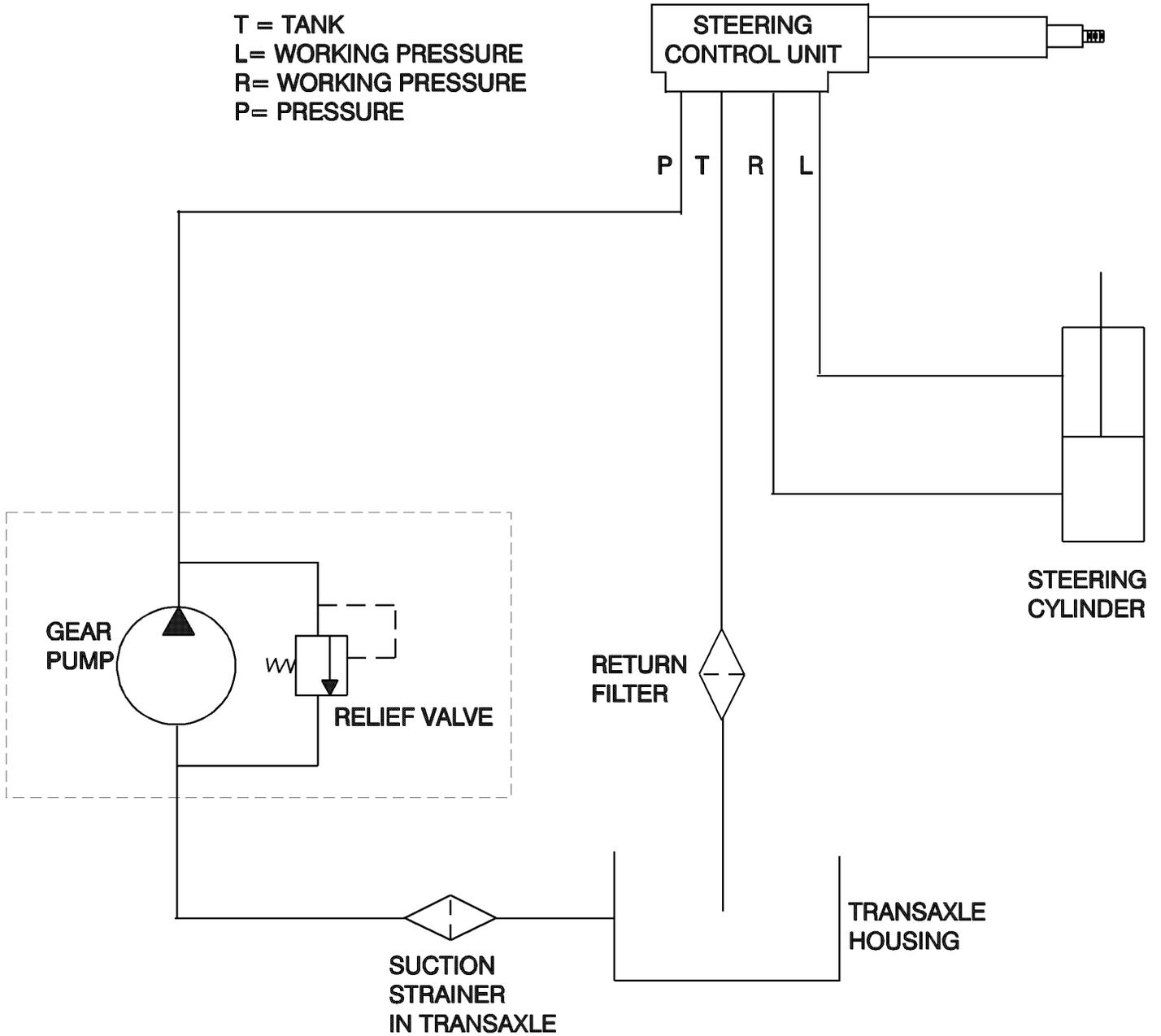

# Vehicle Hydraulic System

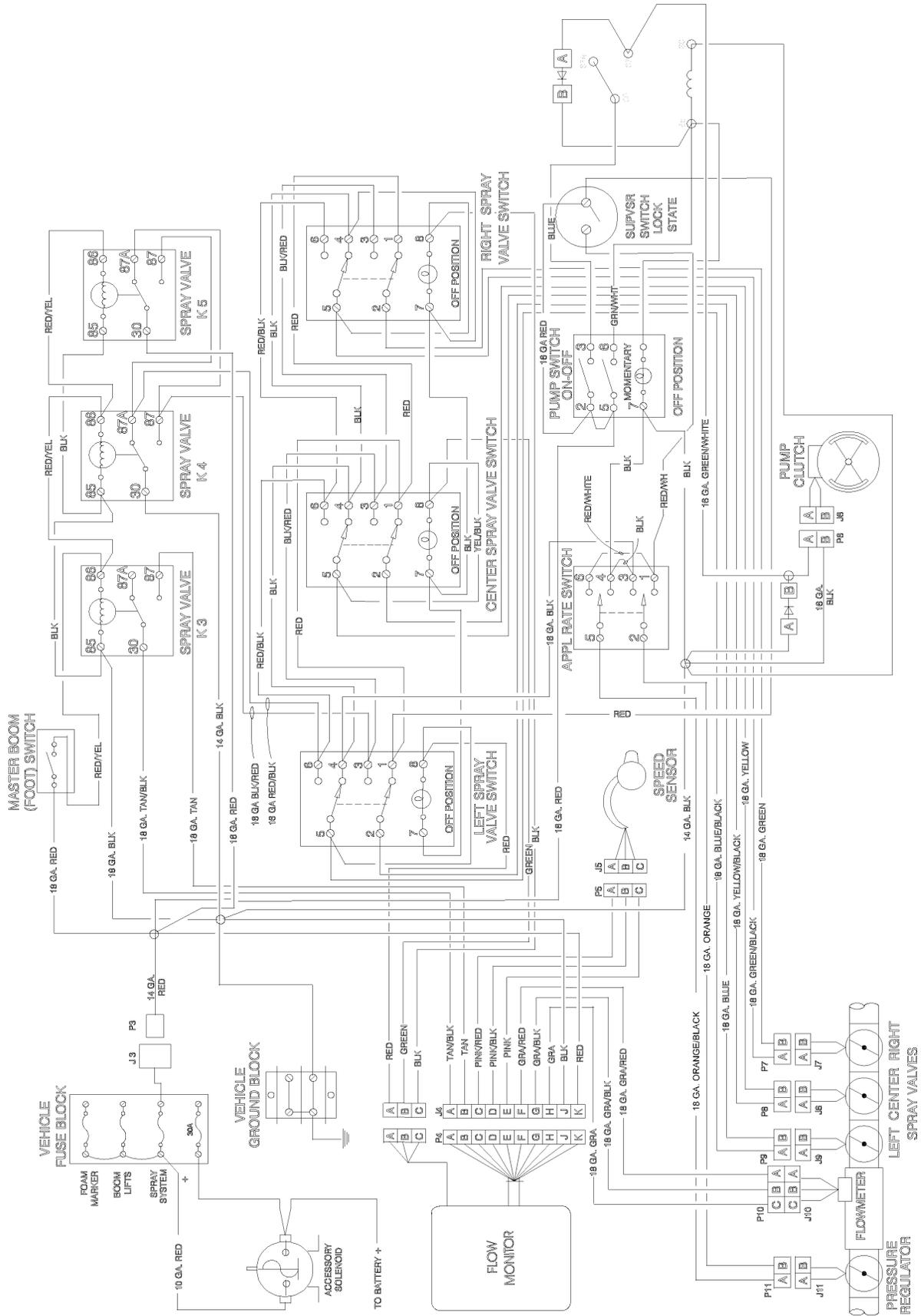

# Spray System Electrical Schematic



# Spray System Flow Diagram

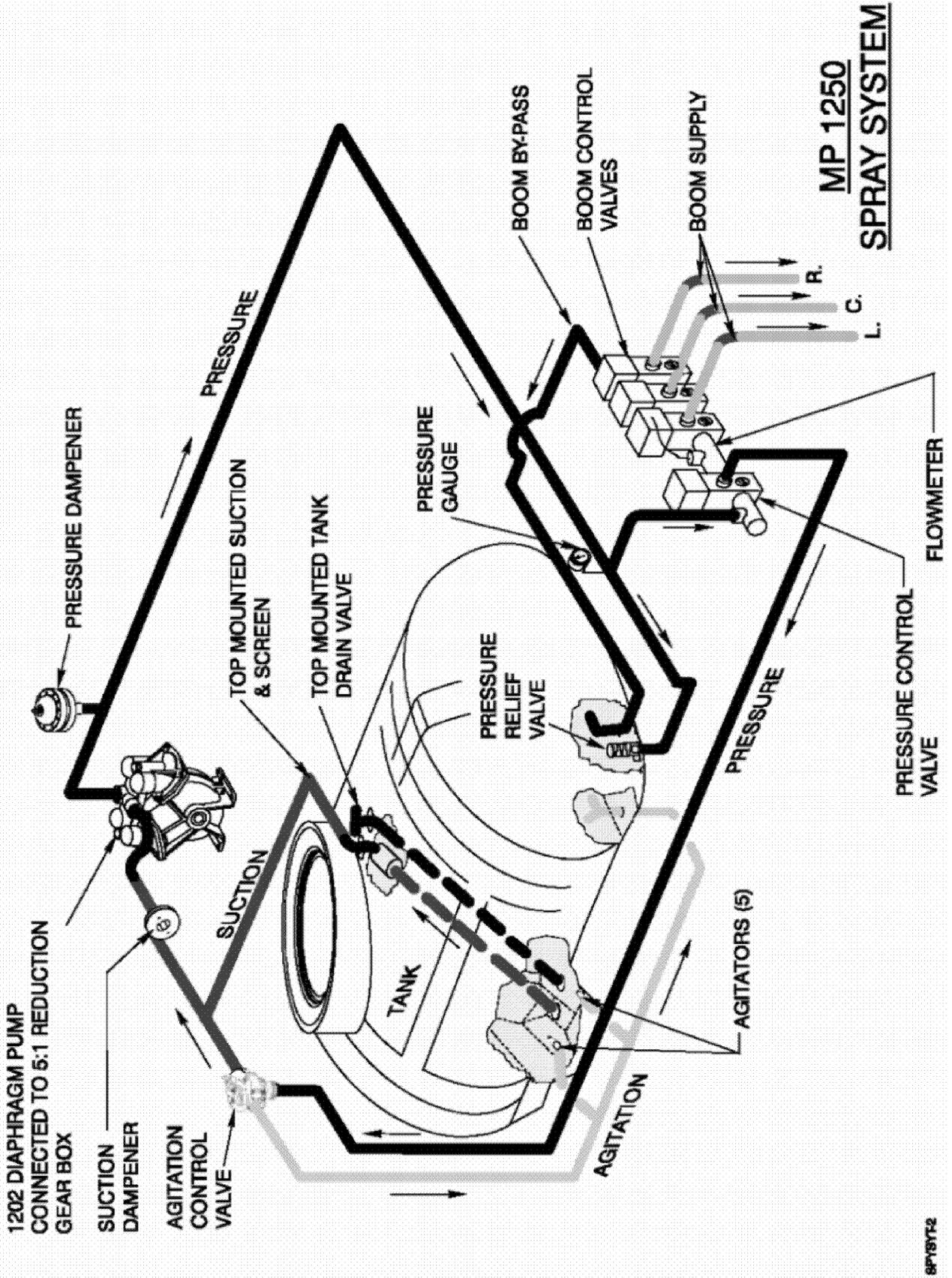



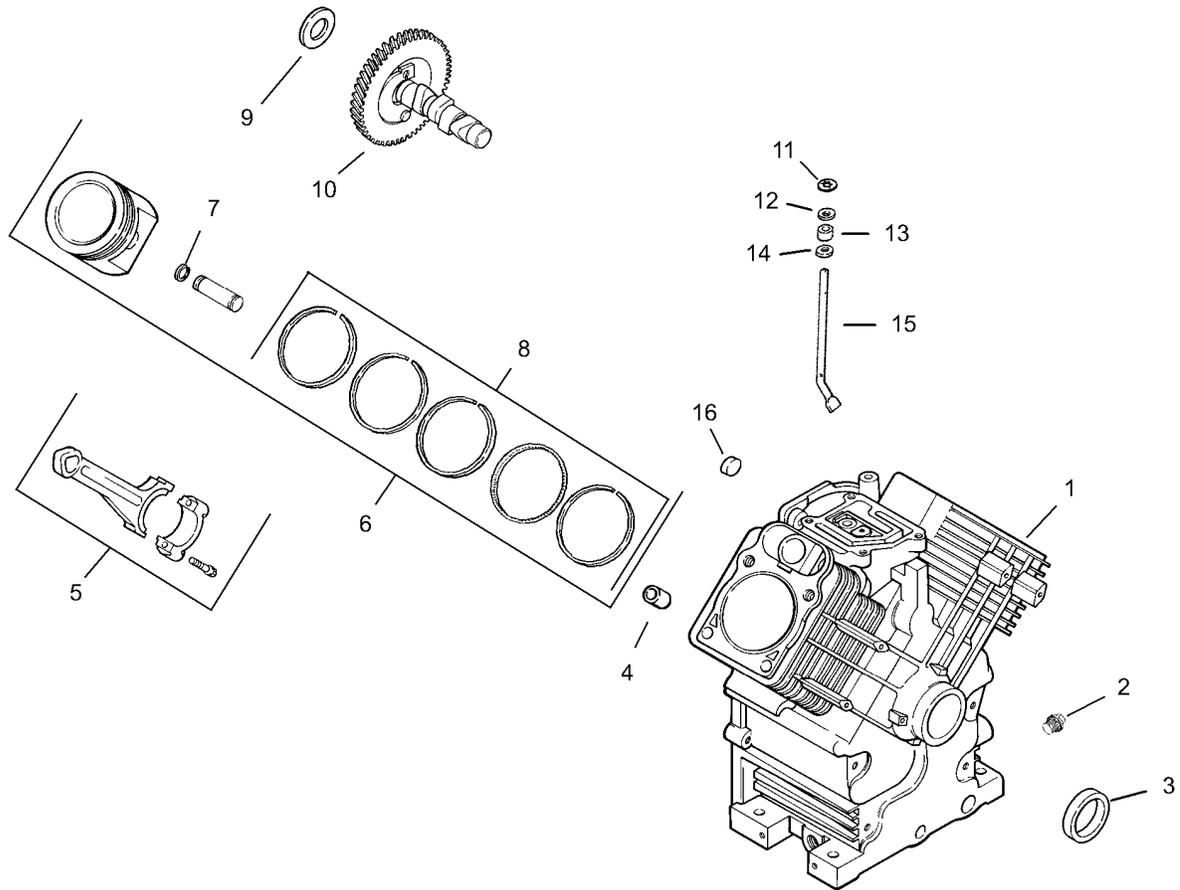

## Crankcase Assembly Kohler CH20S-64647

Ref	Part No.	Qty.	Description
1		1	Cylinder Block (Use Miniblock 24 782 15)
2	25 139 57-S	2	Plug-Pipe, Sq HD (3/8)
3	24 032 01-S	1	Seal-Oil
4	24 380 13-S	6	Pin-Locating
5	24 067 13-S	2	Rod-Connecting (Standard)
6	24 067 14-S	2	Rod-Connecting (.25)
7	24 874 17-S	2	Piston W/Ring Set (STD.)(Incl. Ref. #7 And 8)
8	24 874 14-S	2	Piston ASM (.08)
9	24 874 18-S	2	Piston ASM (.25)
10	24 874 19-S	2	Piston ASM (.50)
11	24 018 01-S	4	Retainer-Pin, Piston
12	24 108 11-S	2	Ring Set (STD And .08)
13	24 108 12-S	2	Ring Set (.25)
14	24 108 13-S	2	Ring Set (.50)
15	12 422 09-S	0	Shim-Camshaft (Red .032)
16	12 422 13-S	0	Shim-Camshaft (Black .04)
17	12 422 07-S	0	Shim-Camshaft (White .028)
18	12 422 08-S	0	Shim-Camshaft (Blue .03)
19	12 422 10-S	0	Shim-Camshaft (Yellow .034)
20	12 422 11-S	0	Shim-Camshaft (Green .036)
21	12 422 12-S	0	Shim-Camshaft (Gray .038)
22	24 012 10-S	1	Camshaft

Ref	Part No.	Qty.	Description
11	24 018 09-S	1	Retainer-Ring
12	M-931010-S	1	Washer-Flat (9Mm)
13	28 032 09-S	1	Seal-Cross Shaft, Governor
14	24 468 15-S	1	Washer-Flat (11/32)
15	24 144 33-S	1	Shaft-Cross, Governor
16	52 139 09-S	1	Plug-Cup

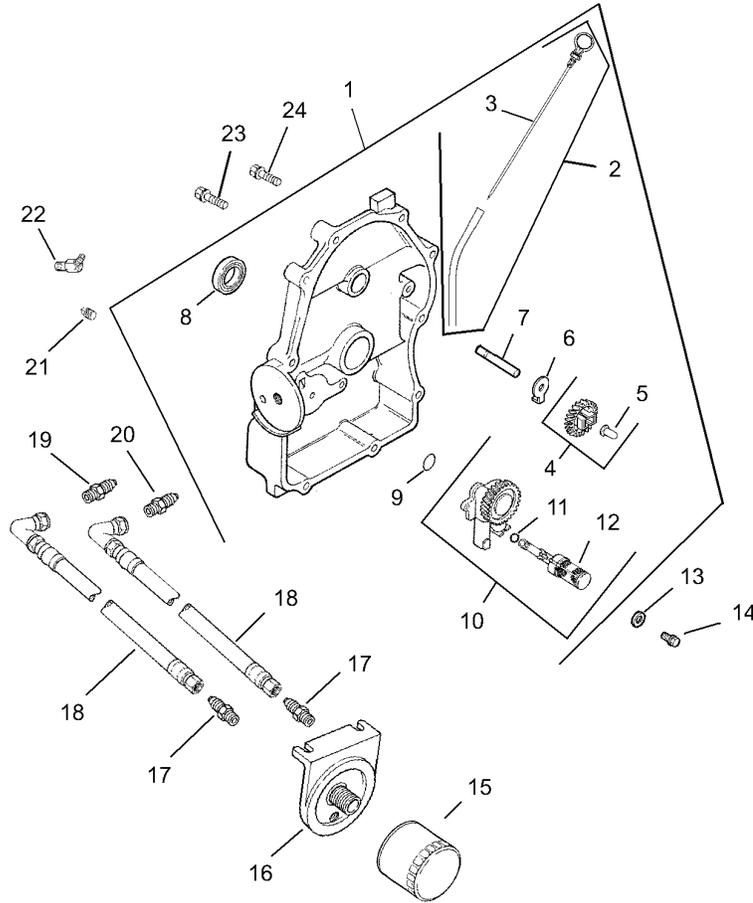

## Oil Pan / Lubrication Assembly Kohler CH20S-6467

Ref	Part No.	Qty.	Description
❶1	24 009 96-S	1	Plate, Closure ASM (Incl. Ref. #2-12,19, 20, 22)
❶2	24 755 121-S	3	Kit, Dipstick W/Tube (Incl. Ref. #3)
❶3	24 038 10-S	1	Dipstick
❶4	24 043 12-S	5	Kit, Governor Gear (Incl. Ref. #5)
❶5	12 380 01-S	1	Pin-Regulating, Governor
❶6	52 448 02-S	1	Tab-Locking
❶7	12 144 02-S	1	Shaft-Gear, Governor
❶8	52 032 08-S	1	Seal-Oil (PTO End)
❶9	24 153 08-S	1	O-Ring
❶10	24 393 37-S	1	Oil Pump Assembly (Incl. Ref. #11, 12)
❶11	24 153 01-S	1	O-Ring
❶12	24 381 04-S	1	Tube-Pick Up, Oil
❶13	M-631005-S	2	Washer-Flat (6 Mm)
❶14	M-645025-S	2	Screw-Flange, Thread Forming (M6X1.0X25)
❶15	52 050 02-S	1	Filter-Oil
❶16	25 029 01-S	1	Adapter-Oil Filter, Remote
❶17	52 155 03-S	2	Connector-Hose
❶18	24 326 46-S	2	Hose-Oil
❶19	24 294 08-S	1	Fitting
❶20	24 294 09-S	1	Fitting-Straight
❶21	25 155 11-S	1	Connector (1/4-18 Npt, 1/2-20 Sae 45 DEG Male Flare)

Ref	Part No.	Qty.	Description
❶22	24 086 16-S	9	Screw-HF (M8X1.25X45)
❶23	24 086 17-S	1	Screw-Flange (M8X1.25X45)
❶❶	25 454 03-S	2	Tie-Wire

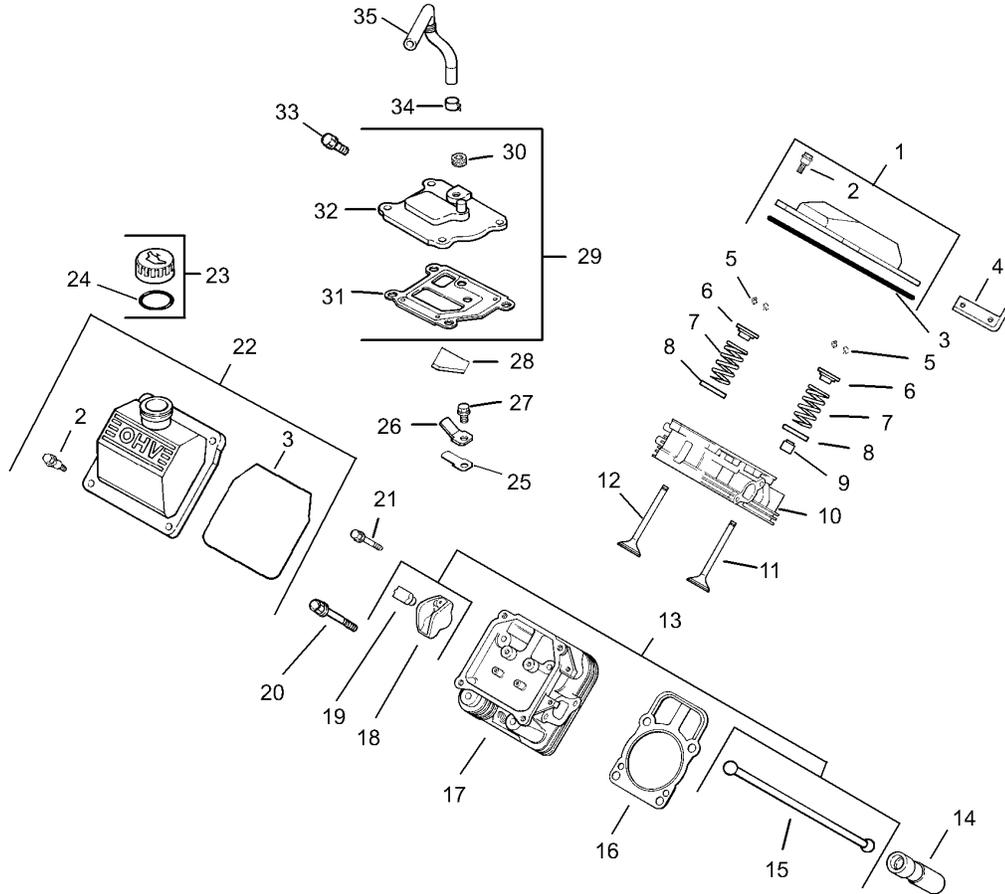

## Head / Valve / Breather Assembly Kohler CH20S-64647

Ref	Part No.	Qty.	Description
❶	24 755 74-S	1	Kit, Valve Cover-Plain (Incl. Ref. #2 And 3)
❷	24 086 32-S	4	Screw-Shoulder (M6X1.0X30)
❸	24 153 23-S	1	O-Ring
❹	24 445 01-S	1	Strap-Lifting
❺	12 755 03-S	4	Retainer Kit
❻	12 173 01-S	4	Cap-Spring, Valve
❼	24 089 02-S	4	Spring-Valve
❽	235011-S	4	Retainer-Spring
❾	66 032 05-S	2	Seal-Stem, Valve
❿	24 318 68-S	1	No. 1 Cylinder Head ASM
⓫	24 017 01-S	2	Valve-Intake (STD)
⓬	24 017 02-S	2	Valve-Intake (.25)
⓭	24 016 01-S	2	Valve-Exhaust (STD)
⓮	24 016 02-S	2	Valve-Exhaust (.25)
⓯	24 755 66-S	1	Kit, Valve Train (Incl. Ref. #15,18,19)
⓰	25 351 01-S	4	Lifter-Valve
⓱	24 411 05-S	4	Rod-Push
⓲	24 041 08-S	2	Gasket-Head, Cylinder
⓳	24 318 71-S	1	No. 2 Cylinder Head ASM
⓴	25 186 01-S	4	Arm-Rocker
⓵	24 599 01-S	4	Pivot-Arm, Rocker
⓶	12 086 16-S	8	Screw-Flange (M10X1.5X90)

Ref	Part No.	Qty.	Description
⓷	M-640034-S	4	Screw-Flange (M6X1.0X34)
⓸	24 559 03-S	1	Kit, Fuel Pump/Valve Cover (Incl. Ref. # 2 And 3)
⓹	24 755 46-S	1	Kit, Oil Fill Cap (Incl. Ref. #24)
⓺	25 153 02-S	1	O-Ring
⓻	24 402 03-S	1	Reed-Breather
⓼	12 018 01-S	1	Retainer-Reed, Breather
⓽	M-545010-S	1	Screw-HHFTF (M5X.8X10)
⓾	24 050 01-S	1	Filter-Breather
⓿	24 033 01-S	1	Kit, Breather(Incl. Ref. #30-32)
Ⓚ	25 139 60-S	1	Plug-Pipe, Countersunk (1/8)
Ⓛ	24 041 23-S	1	Gasket-Breather
Ⓜ	24 096 86-S	1	Cover-Breather
Ⓨ	M-645020-S	4	Screw-HHFTF (M6X1.0X20)
Ⓩ	25 237 14-S	1	Clamp-Hose, Spring (1/2)
Ⓚ	24 326 26-S	0	Hose-Breather

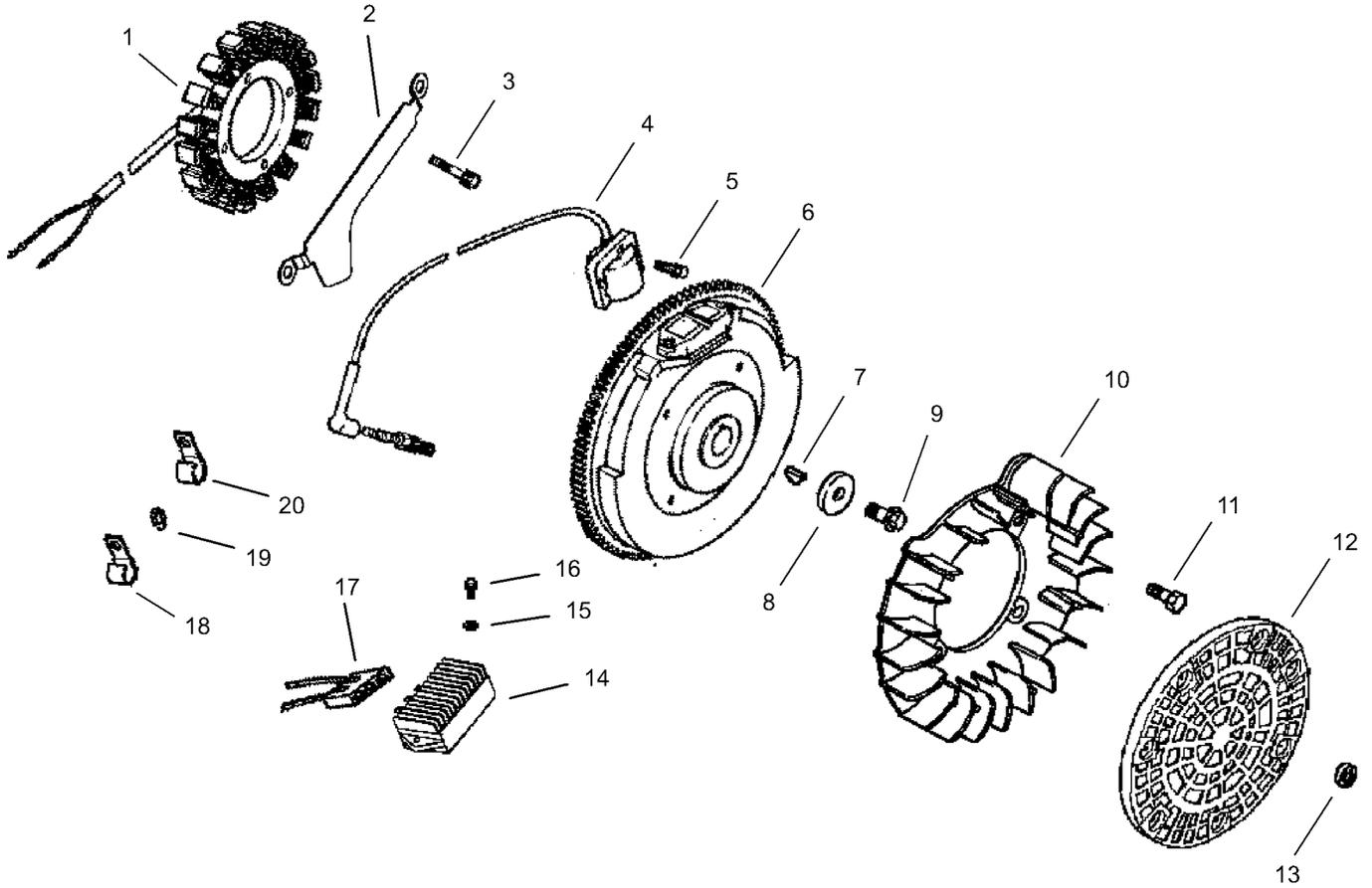

## Ignition / Electrical Assembly Kohler CH20S-64647

Ref	Part No.	Qty.	Description
❶	28 085 02-S	1	Kit, Stator W/Connectors (Incl. Ref. #17)
❷	24 126 71-S	1	Bracket-Wire, Stator
❸	M-545030-S	2	Screw-Cap, Hex (M5X0.8X30)
❹	24 584 01-S	2	Module-Ignition
❺	M-545020-S	4	Screw-Flange, Thread Forming (M5X.8X20)
❻	24 025 01-S	1	Flywheel
❼	X-42-15-S	1	Key (3/16 X 5/8)
❽	12 468 03-S	1	Washer-Flat (13/32)
❾	12 086 14-S	1	Screw-Flange (M10X1.5X45)
❿	24 157 01-S	1	Fan
⓫	25 086 47-S	4	Bolt-Shoulder (M6X1.0X16)
⓬	24 162 03-S	1	Screen-Grass
⓭	24 018 03-S	1	Retainer
⓮	25 403 05-S	1	Rectifier-Regulator (15 Amp)
⓯	X-25-92-S	2	Washer-Flat (.188)
⓰	24 086 18-S	2	Screw-Phl HD (11-16X.88)
⓱	236602-S	1	Connector (3 Contact)
⓲	235173-S	1	Clip-Cable
⓳	X-25-63-S	1	Washer-Flat (1/4)
⓴	48 154 02-S	1	Clip-Cable
⓵	12 132 06-S	2	Spark Plug
⓶	24 518 12-S	1	Lead-Black

Ref	Part No.	Qty.	Description
⓷	24 176 72-S	1	Harness-Wiring
⓸	X-22-11-S	1	Washer-Lock, Internal Tooth (1/4)
⓹	25 454 03-S	2	Tie-Wire



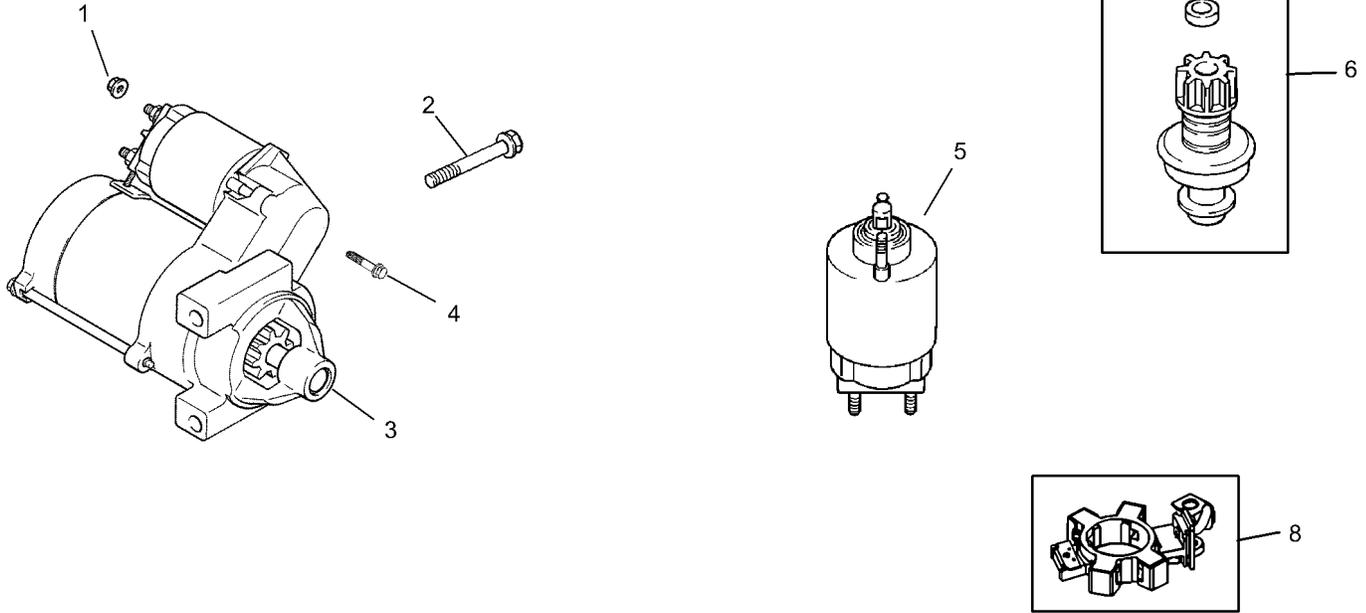

## Starting System Kohler CH20S-64647

Ref	Part No.	Qty.	Description
❶	M-841080-S	1	Nut-Flange (M8X1.25)
❷	M-839080-S	2	Screw-Flig (M8X1.25X80)
❸	24 098 09-S	1	Starter, Solenoid Shift ASM (Incl. Ref. #4-18)
❹	25 086 113-S	3	Screw-Torx Head, External
❺	25 435 05-S	4	Kit, Solenoid (Incl. Ref. #4)
❻	25 755 33-S	7	Kit, Pinion Drive (Incl. Ref. #7)
❼	25 141 05-S	1	Ring-Retaining
❽	25 221 01-S	1	Brush Holder Kit

--	--	--	--

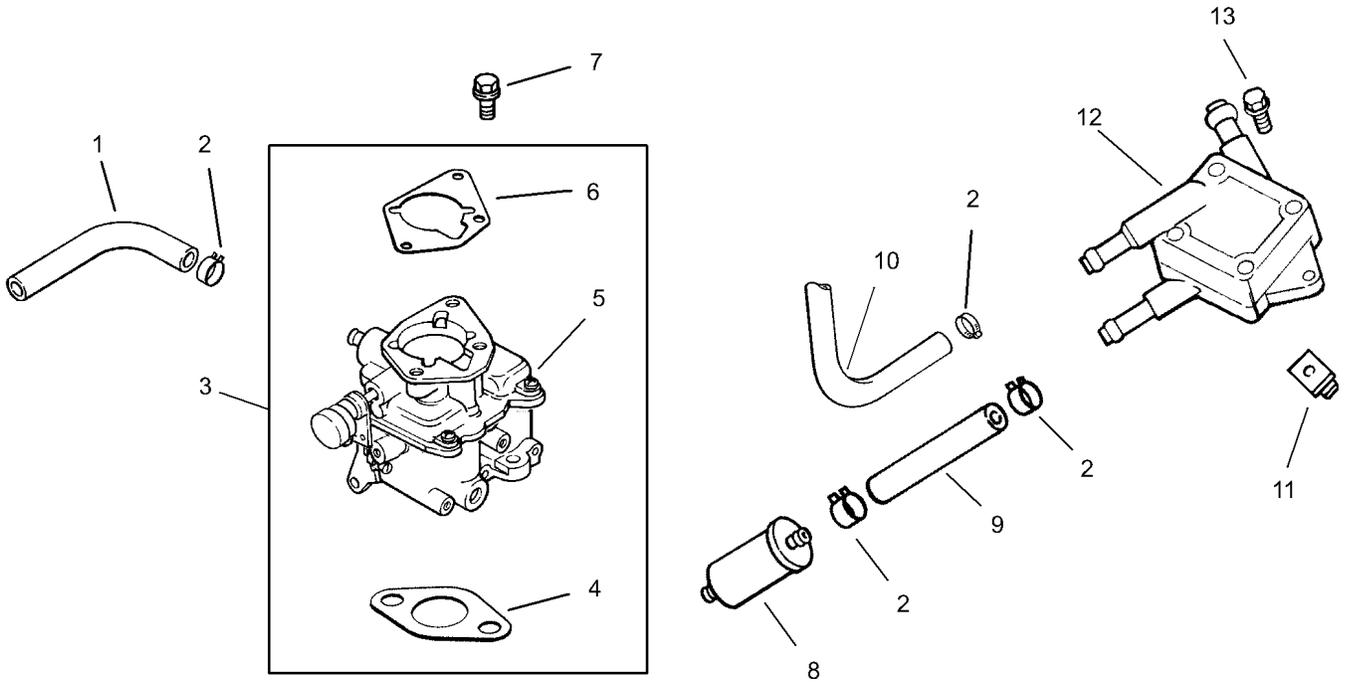

## Fuel System Assembly Kohler CH20S-64647

Ref	Part No.	Qty.	Description
❶	25 353 32-S	1	Line-Fuel (9.5)
❷	25 237 14-S	6	Clamp-Hose, Spring (1/2)
❸	24 853 33-S	1	Kit, Carburetor W/Gasket (Incl. Ref. #4-6)
❹	24 041 06-S	1	Gasket-Base, Air Cleaner
❺		1	Carburetor Assembly (Incl. Ref. #24 75701-S, 24 757 02-S, 24 757 03-S, 24 757 07-S, 24 757 08-S & 24 757 09-S)2405333 (For Information Only Not Available Separately)
❻	24 041 17-S	1	Gasket-Carburetor
❼	M-651030-S	2	Screw-Flange (M6X1.0X30)
❽	24 050 02-S	1	Filter-Fuel
❾	25 353 15-S	1	Line-Fuel (3.5)
❿	24 353 02-S	1	Line-Fuel, Flexible (15.5)
⓫	24 100 01-S	2	Nut-Plastic
⓬	24 393 16-S	1	Pump-Fuel
⓭	24 086 12-S	2	Screw-TAP (M6X1.7X18)
⓯	24 755 125-S	1	High Altitude Kit
⓱	24 757 01-S	1	Solenoid Repair Kit
⓲	24 757 02-S	1	Float Repair Kit
⓳	24 757 03-S	1	Carburetor Repair Kit
⓴	24 757 07-S	1	Choke Repair Kit
⓵	24 757 08-S	1	Accelerator Pump Repair Kit

Ref	Part No.	Qty.	Description
⓯	24 757 09-S	1	Accelerator Pump Seal Repair Kit





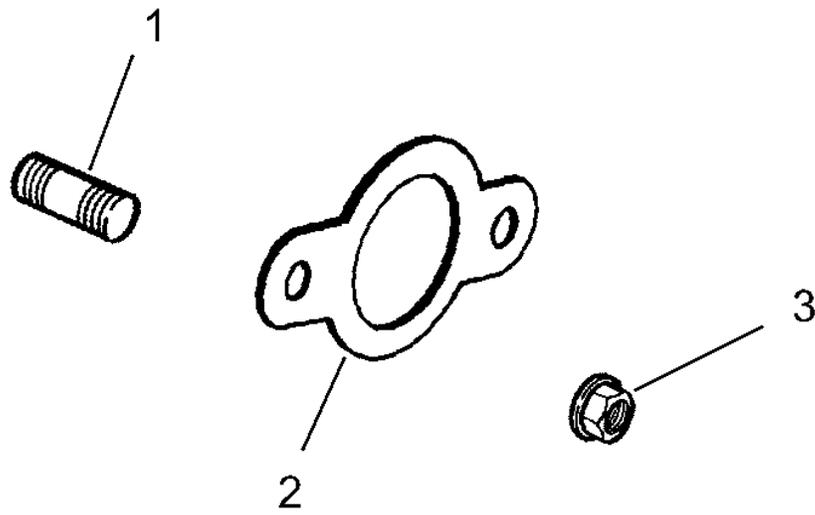

## Exhaust Assembly Kohler CH20S-64647

Ref	Part No.	Qty.	Description
①	25 072 04-S	4	Stud (M8X1.25X33)
②	24 041 49-S	2	Gasket-Exhaust
③	M-841080-S	4	Nut-Flange (M8X1.25)
①②	24522295	1	Short Block ASM
①②	2478215	1	Miniblock
①②	24 755 107-S	1	Gasket Set

## NOTES

