



# Service Manual

## Multi Pro<sup>®</sup> 5600

### Preface

The purpose of this publication is to provide the service technician with information for troubleshooting, testing, and repair of major systems and components on the Multi Pro 5600.

REFER TO THE OPERATOR'S MANUAL FOR OPERATING, MAINTENANCE, AND ADJUSTMENT INSTRUCTIONS. Space is provided in Chapter 2 of this book to insert the Operator's Manual and Parts Catalog for your machine. Replacement Operator's Manuals and Parts Catalogs are available on the internet at [www.Toro.com](http://www.Toro.com).

The Toro Company reserves the right to change product specifications or this publication without notice.



This safety symbol means **DANGER, WARNING, or CAUTION, PERSONAL SAFETY INSTRUCTION**. When you see this symbol, carefully read the instructions that follow. Failure to obey the instructions may result in personal injury.

**NOTE:** A **NOTE** will give general information about the correct operation, maintenance, service, testing, or repair of the machine.

**IMPORTANT:** The **IMPORTANT** notice will give important instructions which must be followed to prevent damage to systems or components on the machine.



This page is intentionally blank.

# Table Of Contents

## Chapter 1 – Safety

Safety Instructions	1 – 2
Jacking Instructions	1 – 4
Safety and Instruction Decals	1 – 4

## Chapter 2 – Product Records and Maintenance

Product Records	2 – 1
Equivalents and Conversions	2 – 2
Torque Specifications	2 – 3
Maintenance	2 – 7

## Chapter 3 – Ford Gasoline Engine

Introduction	3 – 1
Specifications	3 – 2
Adjustments	3 – 3
Service and Repairs	3 – 6
FORD VSG – 411/413 ENGINE SERVICE MANUAL	

## Chapter 4 – Hydraulic System

Specifications	4 – 3
General Information	4 – 4
Hydraulic Schematic	4 – 8
Hydraulic Flow Circuits	4 – 9
Special Tools	4 – 12
Troubleshooting	4 – 14
Testing	4 – 16
Adjustments	4 – 25
Service and Repairs	4 – 27
EATON MODEL 26000 SINGLE GEAR PUMP REPAIR INFORMATION	
EATON MODEL 72400 SERVO CONTROLLED PISTON PUMP REPAIR INFORMATION	
EATON MODEL 74318 and 74348 PISTON MOTORS: FIXED DISPLACEMENT, VALVE PLATE DESIGN REPAIR INFORMATION	
PARKER TORQLINK™ SERVICE PROCEDURE	

## Chapter 5 – Electrical System

Electrical Schematics and Electrical Harness and Connector Drawings	5 – 2
Special Tools	5 – 3
Troubleshooting	5 – 4
Electrical System Quick Checks	5 – 6
Component Testing	5 – 7
Service and Repairs	5 – 22

## Chapter 6 – Spray System

Specifications	6 – 2
General Information	6 – 3
Spray System Flow Diagram	6 – 4
Spray System Operation	6 – 5
Troubleshooting	6 – 6
Service and Repairs	6 – 8

## Chapter 7 – Chassis

Specifications	8 – 2
Service and Repairs	8 – 3

## Chapter 8 – Electrical Diagrams

Electrical Schematics	9 – 3
Circuit Diagrams	9 – 6
Wire Harness Drawings	9 – 13

Safety

Product Records and Maintenance

Ford Gasoline Engine

Hydraulic System

Electrical System

Spray System

Chassis

Electrical Diagrams

This page is intentionally blank.



## Table of Contents

SAFETY INSTRUCTIONS .....	2	JACKING INSTRUCTIONS .....	4
Before Operating .....	2	SAFETY AND INSTRUCTION DECALS .....	4
While Operating .....	2		
Maintenance and Service .....	3		

# Safety Instructions

The Multi Pro 5600 Turf Sprayer is designed and tested to offer safe service when operated and maintained properly. Although hazard control and accident prevention are partially dependent upon the design and configuration of the machine, these factors are also dependent upon the awareness, concern, and proper training of the personnel involved in the operation, transport, maintenance, and storage of the machine. Improper use or maintenance of the machine can result in injury

or death. To reduce the potential for injury or death, comply with the following safety instructions.



## WARNING

To reduce the potential for injury or death, comply with the following safety instructions.

---

### Before Operating

1. Read and understand the contents of the Operator's Manual before starting and operating the machine. Become familiar with the controls and know how to stop the machine and engine quickly. A replacement Operator's Manual is available on the internet at [www.Toro.com](http://www.Toro.com).
2. Keep all shields, safety devices, and decals in place. If a shield, safety device, or decal is defective, illegible or damaged, repair or replace it before operating the machine. Also tighten any loose nuts, bolts or screws to ensure machine is in safe operating condition.
3. Assure interlock switches are adjusted correctly so engine cannot be started unless traction pedal is in the NEUTRAL position.
4. Since gasoline is highly flammable, handle it carefully:
  - A. Store fuel in containers specifically designed for this purpose.
  - B. Do not remove machine fuel tank cap while engine is hot or running.
  - C. Do not smoke while handling fuel.
  - D. Fill fuel tank outdoors and only to within an inch of the top of the tank, not the filler neck. Do not overfill the fuel tank.
  - E. Wipe up any spilled fuel.

---

### While Operating

1. Sit on the seat when starting and operating the machine.
2. Before starting the engine:
  - A. Engage the parking brake.
  - B. Make sure traction pedal is in the NEUTRAL position and the pump switch is OFF.
3. Do not run engine in a confined area without adequate ventilation. Exhaust fumes are hazardous and could possibly be deadly.
4. Do not touch engine, radiator, muffler or exhaust pipe while engine is running or soon after it is stopped. These areas could be hot enough to cause burns.
5. Before getting off the seat:
  - A. Ensure that traction pedal is in the NEUTRAL position.
  - B. Set parking brake.
  - C. Turn pump switch OFF.
  - D. Stop engine and remove key from ignition switch.
  - E. Do not park on slopes unless wheels are chocked or blocked.
6. Follow spray chemical manufacturer's recommendations for handling precautions, protective equipment, and mixing proportions.

---

## Maintenance and Service

1. Before servicing or making adjustments, turn spray pump off, put traction pedal in neutral, stop engine, set parking brake, and remove key from the switch.
2. Prior to servicing sprayer components, determine what chemical(s) have been used in the sprayer. Follow precautions and recommendations printed on chemical container labels or Material Safety Data Sheets when servicing sprayer components. Use appropriate protective equipment: protective clothing, chemical resistant gloves, and eye protection.
3. Make sure machine is in safe operating condition by keeping all nuts, bolts and screws tight.
4. Never store the machine or fuel container inside where there is an open flame, such as near a water heater or furnace.
5. Make sure all hydraulic line connectors are tight and that all hydraulic hoses and lines are in good condition, before applying pressure to the system.
6. Keep body and hands away from pin hole leaks in hydraulic lines that eject high pressure hydraulic fluid. Use cardboard or paper to find hydraulic leaks. Hydraulic fluid escaping under pressure can penetrate skin and cause injury. Fluid accidentally injected into the skin must be surgically removed within a few hours by a doctor familiar with this form of injury or gangrene may result.
7. Before disconnecting or performing any work on the hydraulic system, all pressure in hydraulic system must be relieved. To relieve system pressure, rotate steering wheel in both directions after the key switch has been turned off.
8. If major repairs are ever needed or assistance is desired, contact an Authorized Toro Distributor.
9. To reduce potential fire hazard, keep engine area free of excessive grease, grass, leaves and dirt. Clean protective screen on machine frequently.
10. If engine must be running to perform maintenance or an adjustment, keep clothing, hands, feet, and other parts of the body away from moving parts. Keep bystanders away.
11. Do not overspeed the engine by changing governor setting. To assure safety and accuracy, check maximum engine speed.
12. Shut engine off before checking or adding oil to the crankcase.
13. Disconnect battery before servicing the machine. Disconnect negative (–) battery cable first and positive (+) cable last. If battery voltage is required for troubleshooting or test procedures, temporarily connect the battery. Reconnect positive (+) cable first and negative (–) cable last.
14. Battery acid is poisonous and can cause burns. Avoid contact with skin, eyes, and clothing. Protect your face, eyes, and clothing when working with a battery.
15. Battery gases can explode. Keep cigarettes, sparks, and flames away from the battery.
16. To assure optimum performance and continued safety of the machine, use genuine Toro replacement parts and accessories. Replacement parts and accessories made by other manufacturers may result in non-conformance with safety standards, and the warranty may be voided.
17. When raising the machine to change tires or to perform other service, use correct blocks, hoists, and jacks. Make sure machine is parked on a solid level surface such as a concrete floor. Prior to raising the machine, remove any attachments that may interfere with the safe and proper raising of the machine. Always chock or block wheels. Use jack stands or solid wood blocks to support the raised machine. If the machine is not properly supported by blocks or jack stands, the machine may move or fall, which may result in personal injury (see Jacking Instructions in this Chapter).

# Jacking Instructions



## CAUTION

When raising the machine to change tires or to perform other service, use correct blocks, hoists, and jacks. Make sure machine is parked on a solid level surface such as a concrete floor. Prior to raising machine, remove any attachments that may interfere with the safe and proper raising of the machine. Always chock or block wheels. Use jack stands or solid wood blocks to support the raised machine. If the machine is not properly supported by blocks or jack stands, the machine may move or fall, which may result in personal injury.

### Jacking the Front End

1. Set parking brake and chock both rear tires to prevent the machine from moving.
2. Position jack securely under the front axle, directly beneath the leaf springs (Fig. 1).
3. Jack front of machine off the ground.
4. Position jack stands or hardwood blocks under the axle as close to the wheel as possible to support the machine.

### Jacking the Rear End

1. Set parking brake and chock both front tires to prevent the machine from moving.
2. Place jack securely under the rear most frame supports between the angle welds (Fig. 2).
3. Jack rear of machine off the ground.
4. Position jack stands or hardwood blocks under the frame to support the machine.

## Safety and Instruction Decals

Numerous safety and instruction decals are affixed to the Multi Pro 5600. If any decal becomes illegible or damaged, install a new decal. Part numbers are listed in your Parts Catalog. Order replacement decals from your Authorized Toro Distributor.

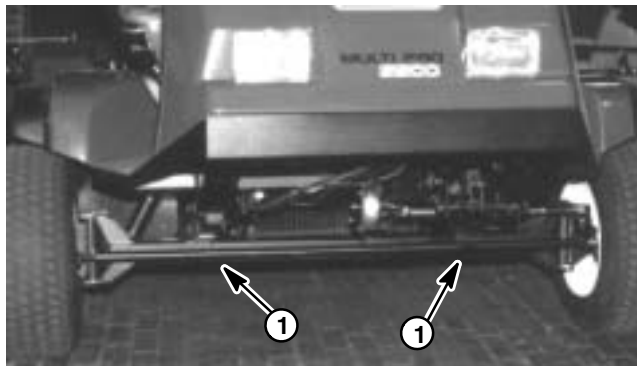

Figure 1

1. Front jacking points

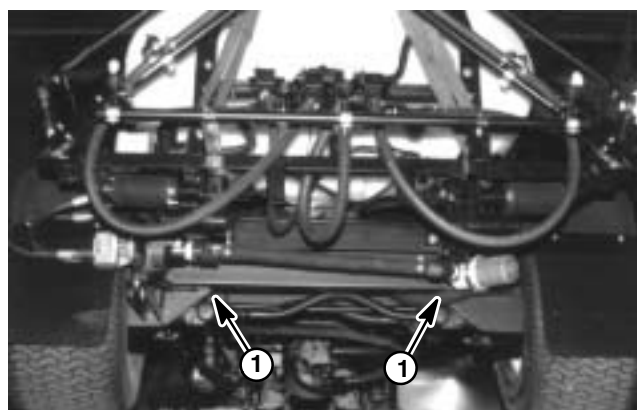

Figure 2

1. Rear jacking points





# Product Records and Maintenance

## Table of Contents

PRODUCT RECORDS .....	1
EQUIVALENTS AND CONVERSIONS .....	2
Decimal and Millimeter Equivalents .....	2
U.S. to Metric Conversions .....	2
TORQUE SPECIFICATIONS .....	3
Fastener Identification .....	3
Standard Torque for Dry, Zinc Plated, and Steel Fasteners (Inch Series Fasteners) .....	4
Standard Torque for Dry, Zinc Plated, and Steel Fasteners (Metric Fasteners) .....	5
Other Torque Specifications .....	6
Conversion Factors .....	6
MAINTENANCE .....	7

## Product Records

Insert Operator’s Manual and Parts Catalog for your Multi Pro 5600 at the end of this chapter. Additionally, if any optional equipment has been installed to your sprayer, insert the Installation Instructions, Operator’s Manuals and Parts Catalogs for those options at the end of this chapter.

# Equivalents and Conversions

## Decimal and Millimeter Equivalents

Fractions	Decimals	mm	Fractions	Decimals	mm			
	1/64	0.015625	— 0.397	33/64	0.515625	— 13.097		
1/32	—	0.03125	— 0.794	17/32	—	0.53125	— 13.494	
	3/64	0.046875	— 1.191	35/64	—	0.546875	— 13.891	
1/16	—	0.0625	— 1.588	9/16	—	0.5625	— 14.288	
	5/64	0.078125	— 1.984	37/64	—	0.578125	— 14.684	
	3/32	—	0.9375	— 2.381	19/32	—	0.59375	— 15.081
	7/64	0.109275	— 2.778	39/64	—	0.609375	— 15.478	
1/8	—	0.1250	— 3.175	5/8	—	0.6250	— 15.875	
	9/64	0.140625	— 3.572	41/64	—	0.640625	— 16.272	
	5/32	—	0.15625	— 3.969	21/32	—	0.65625	— 16.669
	11/64	0.171875	— 4.366	43/64	—	0.671875	— 17.066	
3/16	—	0.1875	— 4.762	11/16	—	0.6875	— 17.462	
	13/64	0.203125	— 5.159	45/64	—	0.703125	— 17.859	
	7/32	—	0.21875	— 5.556	23/32	—	0.71875	— 18.256
	15/64	0.234375	— 5.953	47/64	—	0.734375	— 18.653	
1/4	—	0.2500	— 6.350	3/4	—	0.7500	— 19.050	
	17/64	0.265625	— 6.747	49/64	—	0.765625	— 19.447	
	9/32	—	0.28125	— 7.144	25/32	—	0.78125	— 19.844
	19/64	0.296875	— 7.541	51/64	—	0.796875	— 20.241	
5/16	—	0.3125	— 7.938	13/16	—	0.8125	— 20.638	
	21/64	0.328125	— 8.334	53/64	—	0.828125	— 21.034	
	11/32	—	0.34375	— 8.731	27/32	—	0.84375	— 21.431
	23/64	0.359375	— 9.128	55/64	—	0.859375	— 21.828	
3/8	—	0.3750	— 9.525	7/8	—	0.8750	— 22.225	
	25/64	0.390625	— 9.922	57/64	—	0.890625	— 22.622	
	13/32	—	0.40625	— 10.319	29/32	—	0.90625	— 23.019
	27/64	0.421875	— 10.716	59/64	—	0.921875	— 23.416	
7/16	—	0.4375	— 11.112	15/16	—	0.9375	— 23.812	
	29/64	0.453125	— 11.509	61/64	—	0.953125	— 24.209	
	15/32	—	0.46875	— 11.906	31/32	—	0.96875	— 24.606
	31/64	0.484375	— 12.303	63/64	—	0.984375	— 25.003	
1/2	—	0.5000	— 12.700	1	—	1.000	— 25.400	
	<b>1 mm = 0.03937 in.</b>			<b>0.001 in. = 0.0254 mm</b>				

## U.S. to Metric Conversions

	To Convert	Into	Multiply By
<b>Linear Measurement</b>	Miles	Kilometers	1.609
	Yards	Meters	0.9144
	Feet	Meters	0.3048
	Feet	Centimeters	30.48
	Inches	Meters	0.0254
	Inches	Centimeters	2.54
	Inches	Millimeters	25.4
<b>Area</b>	Square Miles	Square Kilometers	2.59
	Square Feet	Square Meters	0.0929
	Square Inches	Square Centimeters	6.452
	Acre	Hectare	0.4047
<b>Volume</b>	Cubic Yards	Cubic Meters	0.7646
	Cubic Feet	Cubic Meters	0.02832
	Cubic Inches	Cubic Centimeters	16.39
<b>Weight</b>	Tons (Short)	Metric Tons	0.9078
	Pounds	Kilograms	0.4536
	Ounces (Avdp.)	Grams	28.3495
<b>Pressure</b>	Pounds/Sq. In.	Kilopascal	6.895
	Pounds/Sq. In.	Bar	0.069
<b>Work</b>	Foot-pounds	Newton-Meters	1.356
	Foot-pounds	Kilogram-Meters	0.1383
	Inch-pounds	Kilogram-Centimeters	1.152144
<b>Liquid Volume</b>	Quarts	Liters	0.9463
	Gallons	Liters	3.785
<b>Liquid Flow</b>	Gallons/Minute	Liters/Minute	3.785
<b>Temperature</b>	Fahrenheit	Celsius	1. Subtract 32°
			2. Multiply by 5/9

# Torque Specifications

Recommended fastener torque values are listed in the following tables. For critical applications, as determined by Toro, either the recommended torque or a torque that is unique to the application is clearly identified and specified in this Service Manual.

These Torque Specifications for the installation and tightening of fasteners shall apply to all fasteners which do not have a specific requirement identified in this Service Manual. The following factors shall be considered when applying torque: cleanliness of the fastener, use of a thread sealant (e.g. Loctite), degree of lubrication on the fastener, presence of a prevailing torque feature, hardness of the surface underneath the fastener's head, or similar condition which affects the installation.

As noted in the following tables, torque values should be **reduced by 25% for lubricated fasteners** to achieve the similar stress as a dry fastener. Torque values may also have to be reduced when the fastener is threaded into aluminum or brass. The specific torque value should be determined based on the aluminum or brass material strength, fastener size, length of thread engagement, etc.

The standard method of verifying torque shall be performed by marking a line on the fastener (head or nut) and mating part, then back off fastener 1/4 of a turn. Measure the torque required to tighten the fastener until the lines match up.

## Fastener Identification

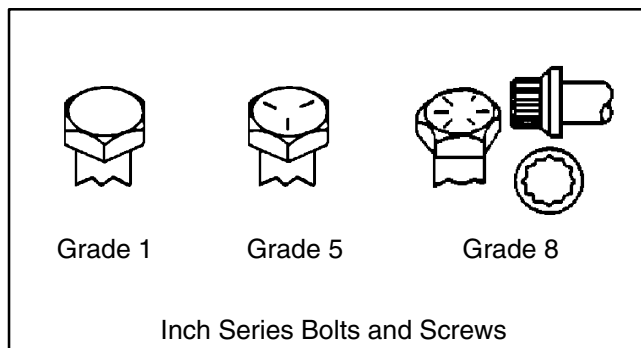

Figure 1

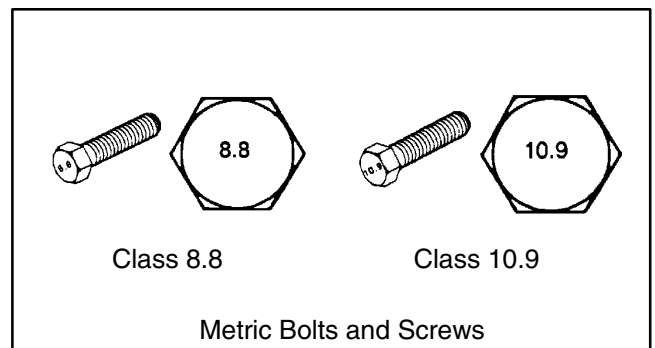

Figure 2

## Standard Torque for Dry, Zinc Plated, and Steel Fasteners (Inch Series Fasteners)

Thread Size	Grade 1, 5, & 8 with Thin Height Nuts	SAE Grade 1 Bolts, Screws, Studs, & Sems with Regular Height Nuts (SAE J995 Grade 2 or Stronger Nuts)		SAE Grade 5 Bolts, Screws, Studs, & Sems with Regular Height Nuts (SAE J995 Grade 2 or Stronger Nuts)		SAE Grade 8 Bolts, Screws, Studs, & Sems with Regular Height Nuts (SAE J995 Grade 5 or Stronger Nuts)	
	in-lb	in-lb	N-cm	in-lb	N-cm	in-lb	N-cm
# 6 – 32 UNC	10 ± 2	13 ± 2	147 ± 23	15 ± 2	170 ± 20	23 ± 2	260 ± 20
# 6 – 40 UNF				17 ± 2	190 ± 20	25 ± 2	280 ± 20
# 8 – 32 UNC	13 ± 2	25 ± 5	282 ± 30	29 ± 3	330 ± 30	41 ± 4	460 ± 45
# 8 – 36 UNF				31 ± 3	350 ± 30	43 ± 4	485 ± 45
# 10 – 24 UNC	18 ± 2	30 ± 5	339 ± 56	42 ± 4	475 ± 45	60 ± 6	675 ± 70
# 10 – 32 UNF				48 ± 4	540 ± 45	68 ± 6	765 ± 70
1/4 – 20 UNC	48 ± 7	53 ± 7	599 ± 79	100 ± 10	1125 ± 100	140 ± 15	1580 ± 170
1/4 – 28 UNF	53 ± 7	65 ± 10	734 ± 113	115 ± 10	1300 ± 100	160 ± 15	1800 ± 170
5/16 – 18 UNC	115 ± 15	105 ± 17	1186 ± 169	200 ± 25	2250 ± 280	300 ± 30	3390 ± 340
5/16 – 24 UNF	138 ± 17	128 ± 17	1446 ± 192	225 ± 25	2540 ± 280	325 ± 30	3670 ± 340
	ft-lb	ft-lb	N-m	ft-lb	N-m	ft-lb	N-m
3/8 – 16 UNC	16 ± 2	16 ± 2	22 ± 3	30 ± 3	41 ± 4	43 ± 4	58 ± 5
3/8 – 24 UNF	17 ± 2	18 ± 2	24 ± 3	35 ± 3	47 ± 4	50 ± 4	68 ± 5
7/16 – 14 UNC	27 ± 3	27 ± 3	37 ± 4	50 ± 5	68 ± 7	70 ± 7	95 ± 9
7/16 – 20 UNF	29 ± 3	29 ± 3	39 ± 4	55 ± 5	75 ± 7	77 ± 7	104 ± 9
1/2 – 13 UNC	30 ± 3	48 ± 7	65 ± 9	75 ± 8	102 ± 11	105 ± 10	142 ± 14
1/2 – 20 UNF	32 ± 3	53 ± 7	72 ± 9	85 ± 8	115 ± 11	120 ± 10	163 ± 14
5/8 – 11 UNC	65 ± 10	88 ± 12	119 ± 16	150 ± 15	203 ± 20	210 ± 20	285 ± 27
5/8 – 18 UNF	75 ± 10	95 ± 15	129 ± 20	170 ± 15	230 ± 20	240 ± 20	325 ± 27
3/4 – 10 UNC	93 ± 12	140 ± 20	190 ± 27	265 ± 25	359 ± 34	375 ± 35	508 ± 47
3/4 – 16 UNF	115 ± 15	165 ± 25	224 ± 34	300 ± 25	407 ± 34	420 ± 35	569 ± 47
7/8 – 9 UNC	140 ± 20	225 ± 25	305 ± 34	430 ± 45	583 ± 61	600 ± 60	813 ± 81
7/8 – 14 UNF	155 ± 25	260 ± 30	353 ± 41	475 ± 45	644 ± 61	660 ± 60	895 ± 81

**NOTE:** Reduce torque values listed in the table above by 25% for lubricated fasteners. Lubricated fasteners are defined as threads coated with a lubricant such as oil, graphite, or thread sealant such as Loctite.

**NOTE:** Torque values may have to be reduced when installing fasteners into threaded aluminum or brass. The specific torque value should be determined based

on the fastener size, the aluminum or base material strength, length of thread engagement, etc.

**NOTE:** The nominal torque values listed above for Grade 5 and 8 fasteners are based on 75% of the minimum proof load specified in SAE J429. The tolerance is approximately ± 10% of the nominal torque value. Thin height nuts include jam nuts.

## Standard Torque for Dry, Zinc Plated, and Steel Fasteners (Metric Fasteners)

Thread Size	Class 8.8 Bolts, Screws, and Studs with Regular Height Nuts (Class 8 or Stronger Nuts)		Class 10.9 Bolts, Screws, and Studs with Regular Height Nuts (Class 10 or Stronger Nuts)	
M5 X 0.8	57 ± 5 in-lb	640 ± 60 N-cm	78 ± 7 in-lb	885 ± 80 N-cm
M6 X 1.0	96 ± 9 in-lb	1018 ± 100 N-cm	133 ± 13 in-lb	1500 ± 150 N-cm
M8 X 1.25	19 ± 2 ft-lb	26 ± 3 N-m	27 ± 2 ft-lb	36 ± 3 N-m
M10 X 1.5	38 ± 4 ft-lb	52 ± 5 N-m	53 ± 5 ft-lb	72 ± 7 N-m
M12 X 1.75	66 ± 7 ft-lb	90 ± 10 N-m	92 ± 9 ft-lb	125 ± 12 N-m
M16 X 2.0	166 ± 15 ft-lb	225 ± 20 N-m	229 ± 22 ft-lb	310 ± 30 N-m
M20 X 2.5	325 ± 33 ft-lb	440 ± 45 N-m	450 ± 37 ft-lb	610 ± 50 N-m

**NOTE:** Reduce torque values listed in the table above by 25% for lubricated fasteners. Lubricated fasteners are defined as threads coated with a lubricant such as oil, graphite, or thread sealant such as Loctite.

**NOTE:** Torque values may have to be reduced when installing fasteners into threaded aluminum or brass. The specific torque value should be determined based

on the fastener size, the aluminum or base material strength, length of thread engagement, etc.

**NOTE:** The nominal torque values listed above are based on 75% of the minimum proof load specified in SAE J1199. The tolerance is approximately ± 10% of the nominal torque value.

## Other Torque Specifications

### SAE Grade 8 Steel Set Screws

Thread Size	Recommended Torque	
	Square Head	Hex Socket
1/4 – 20 UNC	140 ± 20 in-lb	73 ± 12 in-lb
5/16 – 18 UNC	215 ± 35 in-lb	145 ± 20 in-lb
3/8 – 16 UNC	35 ± 10 ft-lb	18 ± 3 ft-lb
1/2 – 13 UNC	75 ± 15 ft-lb	50 ± 10 ft-lb

### Wheel Bolts and Lug Nuts

Thread Size	Recommended Torque**	
7/16 – 20 UNF Grade 5	65 ± 10 ft-lb	88 ± 14 N-m
1/2 – 20 UNF Grade 5	80 ± 10 ft-lb	108 ± 14 N-m
M12 X 1.25 Class 8.8	80 ± 10 ft-lb	108 ± 14 N-m
M12 X 1.5 Class 8.8	80 ± 10 ft-lb	108 ± 14 N-m

\*\* For steel wheels and non-lubricated fasteners.

### Thread Cutting Screws (Zinc Plated Steel)

Type 1, Type 23, or Type F	
Thread Size	Baseline Torque*
No. 6 – 32 UNC	20 ± 5 in-lb
No. 8 – 32 UNC	30 ± 5 in-lb
No. 10 – 24 UNC	38 ± 7 in-lb
1/4 – 20 UNC	85 ± 15 in-lb
5/16 – 18 UNC	110 ± 20 in-lb
3/8 – 16 UNC	200 ± 100 in-lb

### Thread Cutting Screws (Zinc Plated Steel)

Thread Size	Threads per Inch		Baseline Torque*
	Type A	Type B	
No. 6	18	20	20 ± 5 in-lb
No. 8	15	18	30 ± 5 in-lb
No. 10	12	16	38 ± 7 in-lb
No. 12	11	14	85 ± 15 in-lb

\* Hole size, material strength, material thickness & finish must be considered when determining specific torque values. All torque values are based on non-lubricated fasteners.

## Conversion Factors

$$\begin{aligned} \text{in-lb} \times 11.2985 &= \text{N-cm} \\ \text{ft-lb} \times 1.3558 &= \text{N-m} \end{aligned}$$

$$\begin{aligned} \text{N-cm} \times 0.08851 &= \text{in-lb} \\ \text{N-m} \times 0.7376 &= \text{ft-lb} \end{aligned}$$

# Maintenance

Maintenance procedures and recommended service intervals for the Multi Pro 5600 are covered in the Operator's Manual. Refer to that publication when performing regular equipment maintenance. Several maintenance procedures have break-in intervals identified in the Operator's Manual. Refer to the Engine Operator's Manual for additional engine specific maintenance procedures.

This page is intentionally blank.





## Table of Contents

INTRODUCTION .....	1
SPECIFICATIONS .....	2
ADJUSTMENTS .....	3
Governor Oil Level .....	3
Adjust Choke Cable .....	3
Adjust Throttle Control .....	4
Adjust Engine Speed .....	5
SERVICE AND REPAIRS .....	6
Radiator .....	6
Fuel System .....	8
Air Cleaner .....	10
Exhaust System .....	12
Engine .....	14
Removal .....	14
Installation .....	16
Crankshaft Pulley Installation .....	18

FORD VSG – 411/413 ENGINE SERVICE MANUAL

## Introduction

This Chapter gives information about specifications, adjustments and repair of the Ford gasoline engine that powers the Multi Pro 5600.

General maintenance procedures are described in your Operator's Manual. Information on engine troubleshooting, testing, disassembly, and reassembly is identified in the Ford VSG – 411/413 Engine Service Manual that is included at the end of this section.

Most engine repairs and adjustments require tools which are commonly available in many service shops. Special tools are described in the Ford Engine Service Manual. The use of some specialized test equipment is explained. However, the cost of the test equipment and the specialized nature of some repairs may dictate that the work be done at an engine repair facility.

Service and repair parts for Ford gasoline engines are supplied through your local Ford Power Products Distributor.

# Specifications

Item	Description
Make / Designation	Ford, VSG-413, 4-Stroke, Liquid Cooled, OHV
Number of Cylinders	4
Bore x Stroke	73.9mm x 75.4mm (2.90" x 2.96")
Total Displacement	1300 cc (79.3 cu. in.)
Compression Ratio	9.5:1
Firing Order	1 – 2 – 4 – 3 (1 at crankshaft pulley end of engine)
Fuel	Unleaded, Regular Gasoline (Minimum 87 Octane)
Fuel Tank Capacity	40 liter (10.6 gal)
Governor	Mechanical / Belt Driven
Idle Speed (no load)	675 ± 25 RPM
High Idle (no load)	3175 ± 25 RPM
Engine Oil	API SG or higher (see Operator's Manual for viscosity)
Oil Pump	Gear driven trochoid type
Crankcase Oil Capacity	3.25 liter (3.5 qt) with filter
Ignition System	Distributorless Ignition System (DIS) with ignition timing controlled by Universal Electronic Spark Control (UESC)
Starter	12 VDC
Alternator/Regulator	12 VDC 51 Amp
Radiator Coolant Capacity	11.5 liter (12 qt)
Dry Weight (approximate)	108 kg (240 lb)

# Adjustments

## Governor Oil Level

1. Park machine on a level surface, stop engine, engage parking brake, and remove key from the ignition switch.
2. Tip passenger seat to gain access to engine governor assembly.
3. Remove oil level plug from engine governor. If governor oil level is correct, oil should drip from oil level plug hole.
4. If oil level is low, remove oil fill plug and slowly add 10W–30 motor oil until oil in governor begins dripping from oil level plug hole.
5. Reinstall oil level and oil fill plugs to governor.

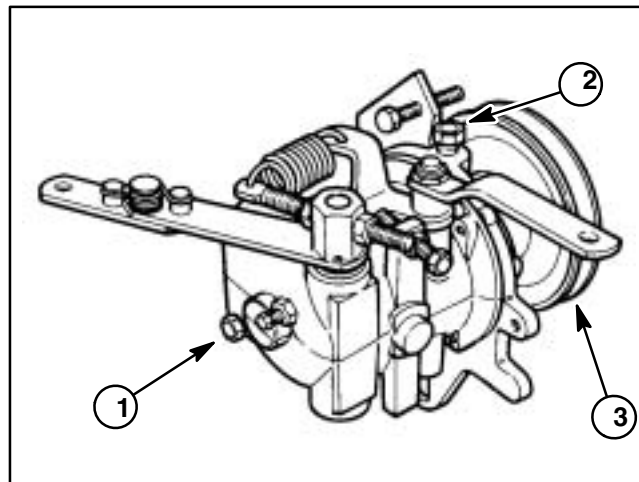

Figure 1

- |                   |                |
|-------------------|----------------|
| 1. Oil level plug | 3. Belt pulley |
| 2. Oil fill plug  |                |

## Adjust Choke Cable

1. Park machine on a level surface, stop engine, engage parking brake, and remove key from the ignition switch.
2. Tip passenger seat to gain access to carburetor.
3. Loosen hose clamps that secure carburetor elbow to carburetor. Remove carburetor elbow from carburetor (Fig. 2).
4. Move choke control on control panel while watching choke plate in carburetor.
  - A. Choke plate should be fully open when choke control is pushed in.
  - B. Choke plate should be fully closed when choke control is pulled out.
5. If cable adjustment is needed, loosen cap screw and washer that secure choke cable to carburetor. Reposition cable to allow correct choke operation. If needed, loosen screw on choke lever swivel and reposition cable at swivel. Tighten all fasteners.
6. After adjustment, recheck choke operation.

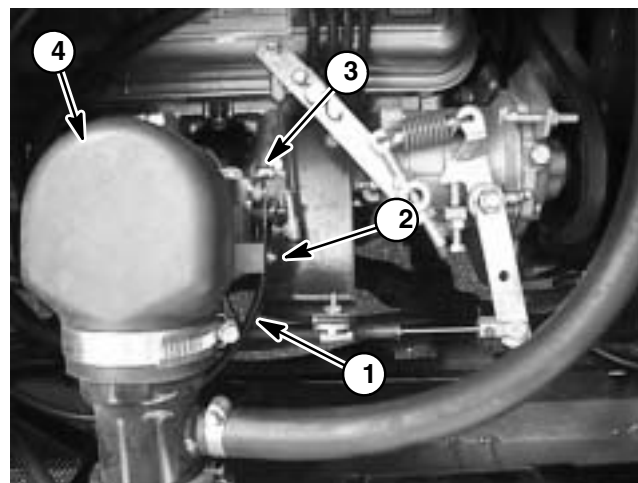

Figure 2

- |                       |                     |
|-----------------------|---------------------|
| 1. Choke cable        | 3. Choke lever      |
| 2. Cap screw w/washer | 4. Carburetor elbow |

**IMPORTANT: Any leaks in the air intake system will cause serious engine damage. Make sure that the carburetor elbow is installed properly during re-assembly.**

7. Reinstall and secure carburetor elbow.

## Adjust Throttle Control

If the throttle control will not stay in position or if engine speed cannot be adjusted for both low idle and high idle speed, the throttle control may need adjustment.

1. Park machine on a level surface, stop engine, engage parking brake, and remove key from the ignition switch.

2. Remove knob from throttle lever and remove switch panel from spray control console to gain access to throttle control.

3. If throttle control will not stay in position, tighten lock nut at control pivot.

4. If throttle control will not allow full range of engine RPM, adjust throttle control stop screws as needed to increase throttle lever movement.

5. After any throttle control adjustment, check engine speed and adjust if needed (see Adjust Engine Speed in this section).

6. Install switch panel to spray control console. Install knob to throttle lever.

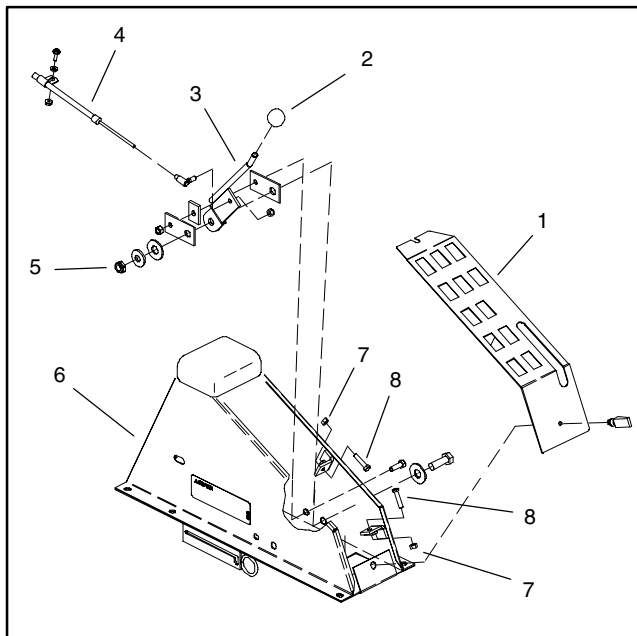

Figure 3

- |                   |                          |
|-------------------|--------------------------|
| 1. Switch panel   | 5. Pivot lock nut        |
| 2. Knob           | 6. Spray control console |
| 3. Throttle lever | 7. Jam nut               |
| 4. Throttle cable | 8. Stop screw            |

## Adjust Engine Speed

1. Park machine on a level surface, stop engine, engage parking brake, and remove key from the ignition switch. Tip passenger seat to gain access to engine speed control (Fig. 4).

2. With engine stopped, move throttle control to **FAST** position. Check distance between carburetor throttle shaft lever and stop on carburetor base to make sure there is a 1/32" to 1/16" (.8 mm to 1.6 mm) gap. If this gap is incorrect, adjust throttle control rod (Fig. 4) by turning ball joint ends until gap is correct. When gap is correct, proceed with following steps.

3. Start engine and allow engine to reach normal, operating temperature.



### CAUTION

**The engine must be running to perform engine speed adjustment. To avoid personal injury, be cautious of rotating fan, hot engine components and moving parts.**

4. With engine running, move throttle control to **SLOW** position.

5. Manually rotate throttle shaft so it is against the carburetor stop screw (closed position). Using a tachometer, check that engine is operating at **675 ± 25 RPM**. If engine speed is incorrect, adjust carburetor stop screw. Release throttle shaft.

**IMPORTANT: While adjusting engine high idle speed, do not allow engine to over-speed.**

6. Move throttle control to **FAST** position. Using a tachometer, check that engine is operating at **3175 ± 25 RPM**. If high idle engine speed is incorrect, loosen jam nut on high idle stop screw (Fig. 4) and adjust stop screw until engine is running at **3175 ± 25 RPM**. Tighten jam nut and recheck high idle speed.

7. After speed adjustments are completed, check governor operation:

A. With engine running at **SLOW** speed, move throttle control rapidly from **SLOW** to **FAST**. Engine speed should rise to correct high idle speed (**3175 ± 25 RPM**) and should not surge.

B. With engine running at **FAST** speed, manually nudge throttle shaft so engine increases momentarily. Engine speed should return quickly to high idle speed (**3175 ± 25 RPM**) and should not surge.

8. If governor operation is incorrect or if the engine surges, check the following:

- A. Governor drive belt is loose or damaged (see Operator's Manual).
- B. Throttle linkage is binding.
- C. Carburetor mixture is incorrect.
- D. Governor sensitivity or no-load surge screw on governor is incorrectly adjusted (see Ford VSG – 411/413 Engine Service Manual at the end of this Chapter).
- E. Governor assembly is worn internally.

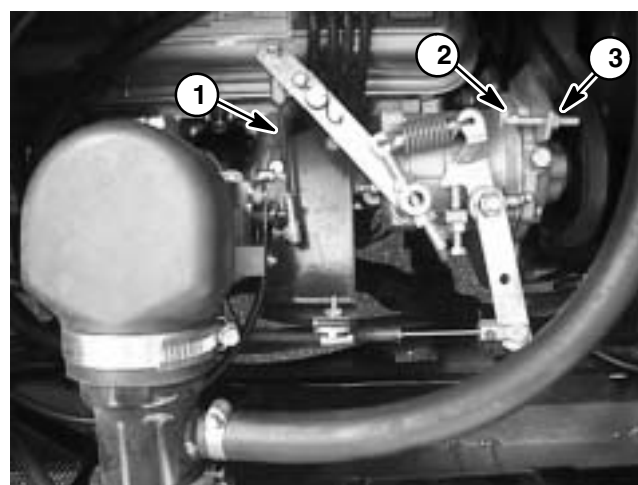

Figure 4

- 1. Throttle control rod
- 2. High idle stop screw
- 3. Jam nut

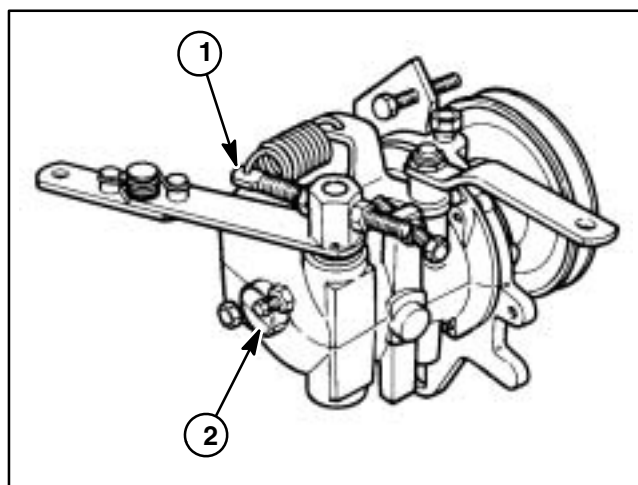

Figure 5

- 1. Sensitivity adjust rod
- 2. Anti-surge screw

# Service and Repairs

## Radiator

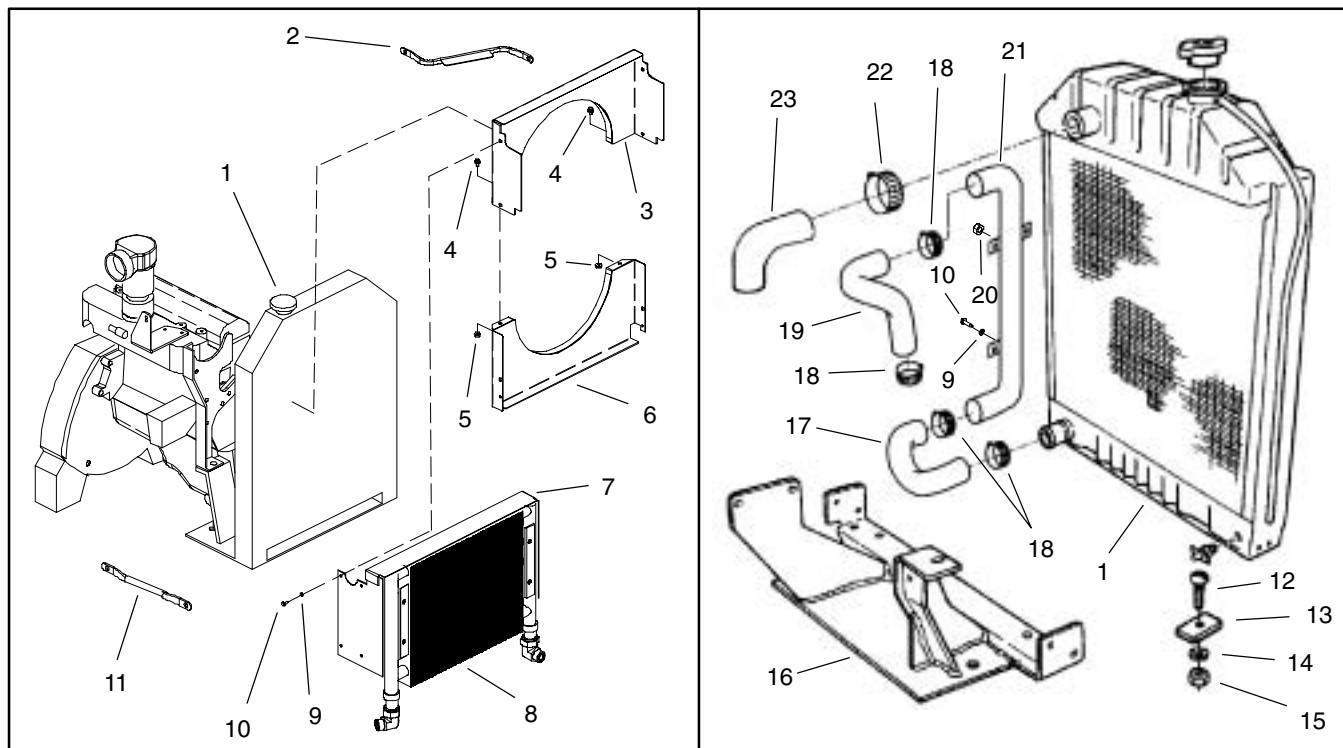

Figure 6

- |                              |                                  |                      |
|------------------------------|----------------------------------|----------------------|
| 1. Radiator                  | 9. Lock washer (11 used)         | 17. Lower hose       |
| 2. LH radiator support brace | 10. Self-tapping screw (11 used) | 18. Hose clamp       |
| 3. Upper radiator shroud     | 11. RH radiator support brace    | 19. Pump inlet hose  |
| 4. Flange head screw         | 12. Bolt (2 used)                | 20. Hex nut (2 used) |
| 5. Hex nut                   | 13. Cushion (2 used)             | 21. Radiator tube    |
| 6. Lower radiator shroud     | 14. Flat washer (2 used)         | 22. Hose clamp       |
| 7. Oil cooler shroud         | 15. Hex nut (2 used)             | 23. Upper hose       |
| 8. Oil cooler                | 16. Engine support frame         |                      |

### Removal (Figs. 6)

1. Park machine on a level surface, stop engine, engage parking brake, and remove key from the ignition switch. Raise seats of machine to allow access to engine compartment.

3. Loosen hose clamps and disconnect both pump inlet and upper hoses from the engine.

4. Loosen fasteners on both radiator support braces. Pivot support braces away from radiator.

5. Remove two (2) flange head screws and hex nuts that secure upper and lower radiator shrouds.

6. On the left side of the radiator:

A. Remove four (4) self-tapping screws and lock washers that secure oil cooler shroud to radiator.

B. Remove two (2) hex nuts and one (1) self-tapping screw and lock washer that secure radiator tube to radiator.

C. Remove self-tapping screw and lock washer that secures lower radiator shroud to radiator.



### CAUTION

**Do not open radiator cap or drain coolant if the radiator or engine is hot. Pressurized, hot coolant can escape and cause burns. Ethylene-glycol antifreeze is poisonous. Dispose of coolant properly, or store it in a properly labeled container away from children and pets.**

2. Drain radiator into a suitable container using the radiator drain (see Operator's Manual).

7. On the right side of the radiator:
  - A. Remove four (4) self-tapping screws and lock washers that secure oil cooler shroud to radiator.
  - B. Remove self-tapping screw and lock washer that secures lower radiator shroud to radiator.
8. Remove control cables from engine (Fig. 7).
  - A. Loosen and remove cap screw and nut that secure end of throttle cable to governor lever. Loosen and remove screw, flat washer and flange nut that secure throttle cable clamp to control bracket.
  - B. Loosen screw that secures choke cable to choke lever swivel. Loosen screw with washer that secures choke cable to carburetor.
9. Loosen hose clamp that secures air breather hose to air intake tube (Fig. 8). Remove hose from tube and pull hose through ring on bottom of spray control console.
10. Remove fasteners that secure spray control console to seat box assembly (Fig. 8). Carefully pivot seats and control console forward to allow radiator access taking care not to damage wiring harness or throttle cable.
11. Carefully pull upper radiator shroud from radiator.
12. Remove two (2) bolts, flat washers, and hex nuts that secure the bottom of the radiator to the engine support frame.
13. Carefully pull radiator up from the machine. Locate and retrieve cushions from between radiator and frame.

**Installation (Figs. 6)**

1. Position radiator to the engine support frame. Place cushions between radiator and frame. Secure radiator to the support frame with two (2) bolts, flat washers and hex nuts.
2. Position lower and upper radiator shrouds and oil cooler shroud to radiator. Attach shrouds to the radiator with self-tapping screws and lock washers. Make sure that clearance exists between radiator shrouds and fan at all points. Secure upper and lower shrouds with flange head screws and hex nuts.
3. Position radiator tube to radiator. Secure tube to the radiator with hex nuts and self-tapping screw with lock washer.
4. Connect pump inlet and upper hoses to the engine. Secure hoses with hose clamps.
5. Pivot radiator support braces to the radiator. Tighten fasteners to secure braces to engine and radiator.

6. Carefully pivot seats and spray control console back in position taking care not to damage wiring harness or throttle cable. Install fasteners to secure control console to seat box assembly.
7. Route throttle and choke cables to engine. Install choke cable to carburetor and throttle cable to control bracket (Fig. 7). Adjust choke cable (see Adjust Choke Cable in the Adjustments Section of this Chapter).
8. Pull air breather hose through ring on bottom of spray control console and install hose to air intake tube (Fig. 8). Secure hose with hose clamp.
9. Make sure radiator drain is closed. Fill radiator with coolant (see Operator's Manual).
10. Check position of wires, hydraulic hoses, and control cables for proper clearance with rotating, high temperature, and moving components.
11. Start engine and check for proper operation. Check all hose connections for leaks. Check engine speed and adjust if needed (see Adjust Engine Speed in the Adjustments section of this Chapter).

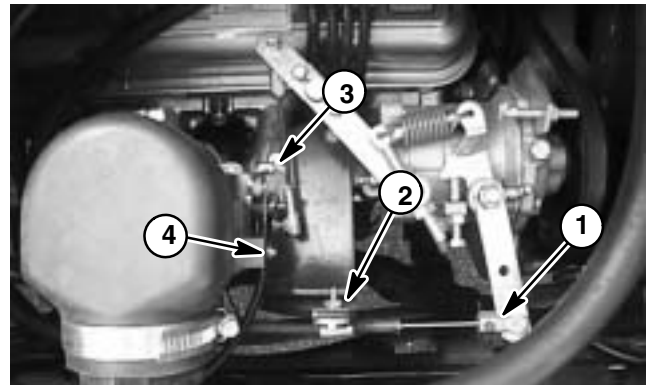

Figure 7

- |                         |                       |
|-------------------------|-----------------------|
| 1. Throttle cable end   | 3. Choke lever swivel |
| 2. Throttle cable clamp | 4. Screw w/washer     |



Figure 8

- |                      |                           |
|----------------------|---------------------------|
| 1. Air breather hose | 2. Spray console fastener |
|----------------------|---------------------------|

# Fuel System

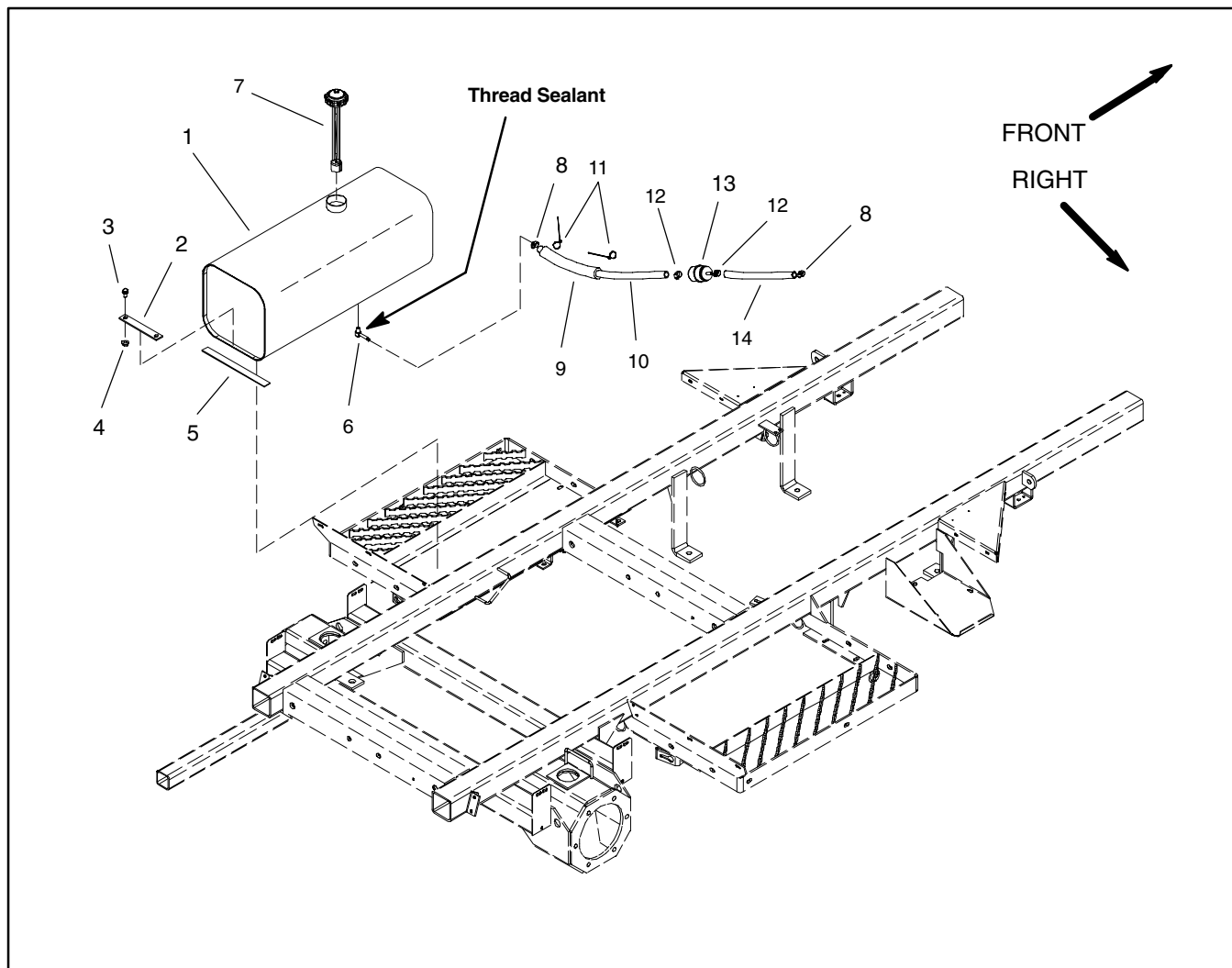

Figure 9

- |                               |                        |                           |
|-------------------------------|------------------------|---------------------------|
| 1. Fuel tank                  | 6. Elbow fitting       | 11. Cable tie             |
| 2. Hold down strap (2 used)   | 7. Fuel cap with gauge | 12. Hose clamp            |
| 3. Flange head screw (4 used) | 8. Hose clamp          | 13. Fuel filter (in-line) |
| 4. Flange nut (4 used)        | 9. Fuel line conduit   | 14. Fuel hose             |
| 5. Cushion strip (2 used)     | 10. Fuel hose          |                           |





## DANGER

Because gasoline is highly flammable, use caution when storing or handling it. Do not smoke while filling the fuel tank. Do not fill fuel tank while engine is running, hot, or when machine is in an enclosed area. Always fill fuel tank outside and wipe up any spilled fuel before starting the engine. Store fuel in a clean, safety-approved container and keep cap in place. Use gasoline for the engine only; not for any other purpose.

### Check Fuel Lines and Connections

Check fuel lines and connections periodically as recommended in the Operator's Manual. Check lines for deterioration, damage, leaking, or loose connections. Replace hoses, clamps, and connections as necessary.

### Drain and Clean Fuel Tank

Drain and clean the fuel tank if the fuel system becomes contaminated or if the machine is to be stored for an extended period.

To clean fuel tank, flush tank out with clean solvent. Make sure tank is free of contaminants and debris.

### Fuel Tank Removal

1. Park machine on a level surface, stop engine, engage parking brake, and remove key from the ignition switch.
2. Remove cable ties that secure fuel line to machine frame. Note location of cable ties.
3. Clamp fuel hose between the fuel tank and fuel filter to prevent leakage (Fig. 10). Disconnect fuel hose from the fuel filter.
4. Unclamp fuel hose and empty fuel tank into a suitable container.
5. Remove fuel tank using Figure 9 as a guide.

### Fuel Tank Installation

1. Install fuel tank to frame using Figure 9 as a guide.
2. Connect fuel hose to the fuel filter.
3. Secure fuel line to frame with cable ties.
4. Fill fuel tank (see Operator's Manual).
5. Start engine and check fuel line connections for any leakage.

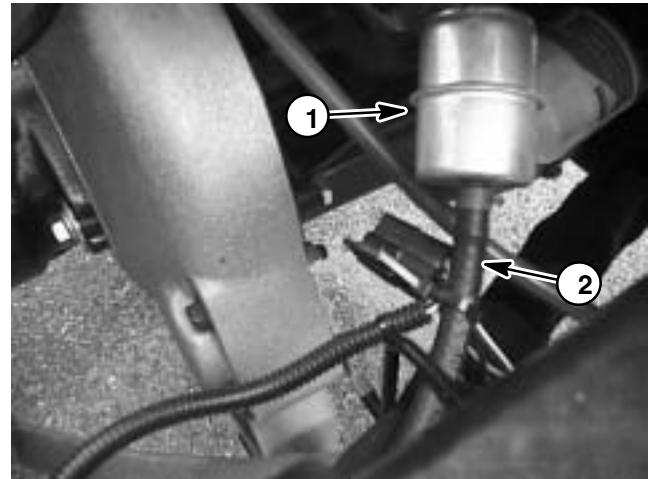

Figure 10

1. Fuel filter

2. Fuel hose (from tank)

# Air Cleaner

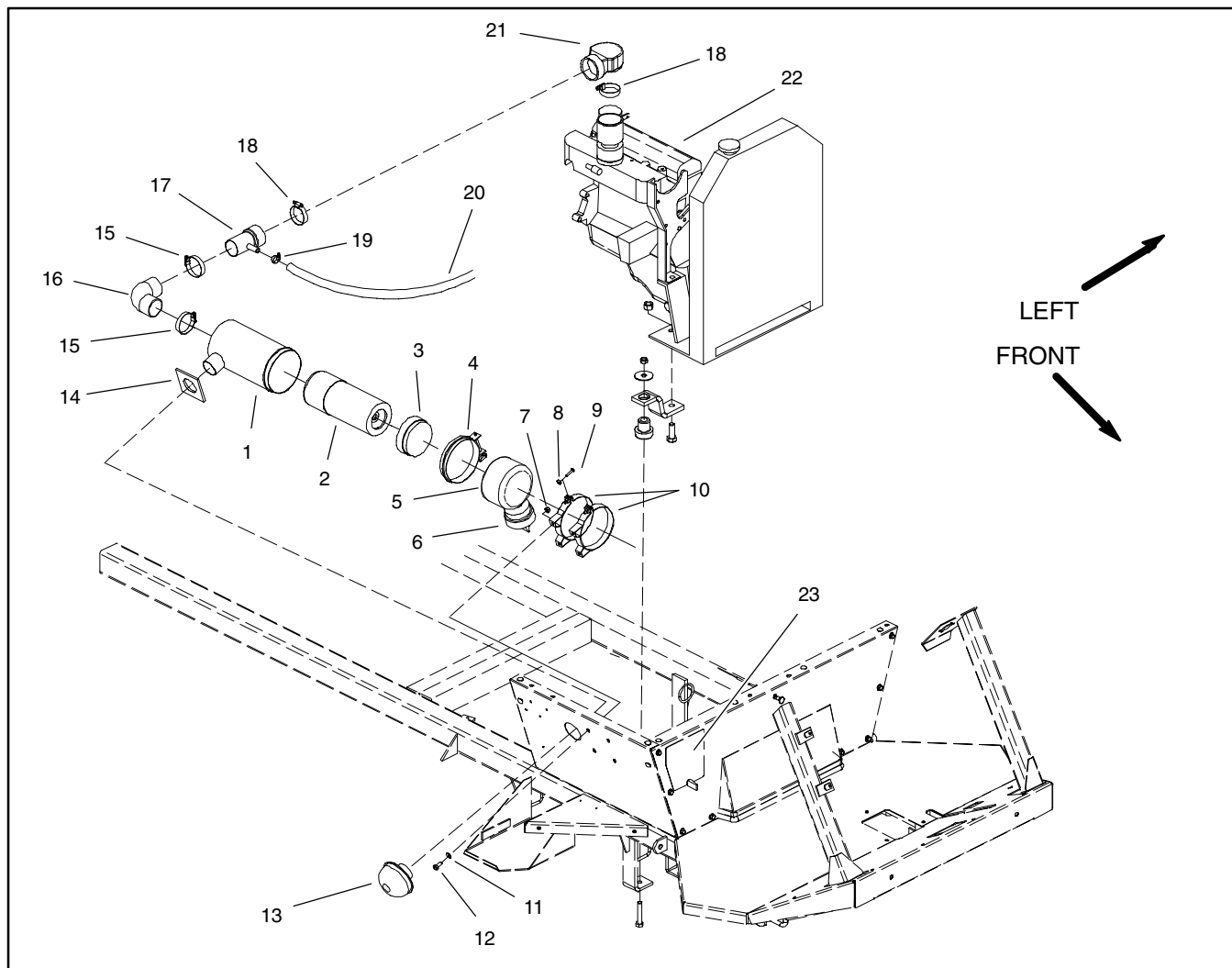

Figure 11

- |                                 |                                   |  |
|---------------------------------|-----------------------------------|--|
| 1. Air cleaner housing          | 9. Screw (1 used per band)        | 17. Intake tube                        |
| 2. Air filter element           | 10. Mounting band                 | 18. Hose clamp                         |
| 3. Baffle skirt                 | 11. Flat washer (2 used per band) | 19. Hose clamp                         |
| 4. Clamp                        | 12. Cap screw (4 used)            | 20. Breather tube (to engine oil fill) |
| 5. Cup                          | 13. Air cleaner cap               | 21. Carb inlet elbow                   |
| 6. Vacuum valve                 | 14. Foam seal                     | 22. Engine                             |
| 7. Hex nut (4 used)             | 15. Hose clamp                    | 23. Air cleaner access panel           |
| 8. Square nut (1 used per band) | 16. Hose elbow                    |  |

### Removal (Fig. 11)

**NOTE:** For air cleaner maintenance information, refer to the Operator's Manual.

1. Remove air cleaner access panel from the front panel of the seat base and raise passenger seat to access air cleaner assembly.
2. Remove air cleaner components as needed using Figures 11 and 12 as guides.

### Installation (Fig. 11)

**IMPORTANT:** Any leaks in the air filter system will cause serious engine damage. Make sure that all air cleaner components are in good condition and are properly secured during reassembly.

1. Reassemble air cleaner system using Figures 11 and 12 as guides.

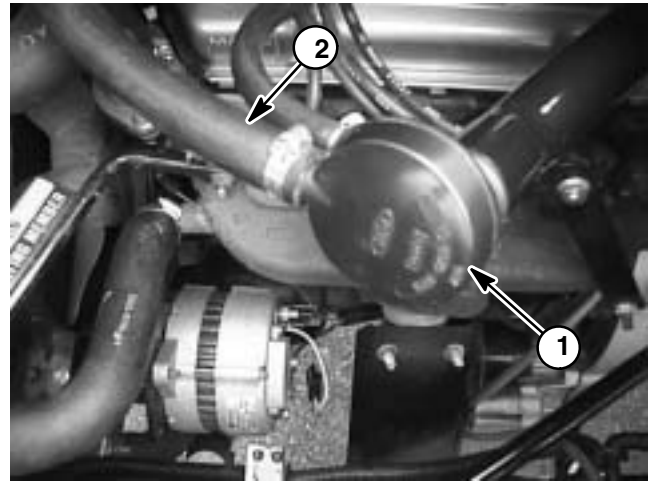

Figure 12

1. Engine oil fill

2. Breather tube

# Exhaust System

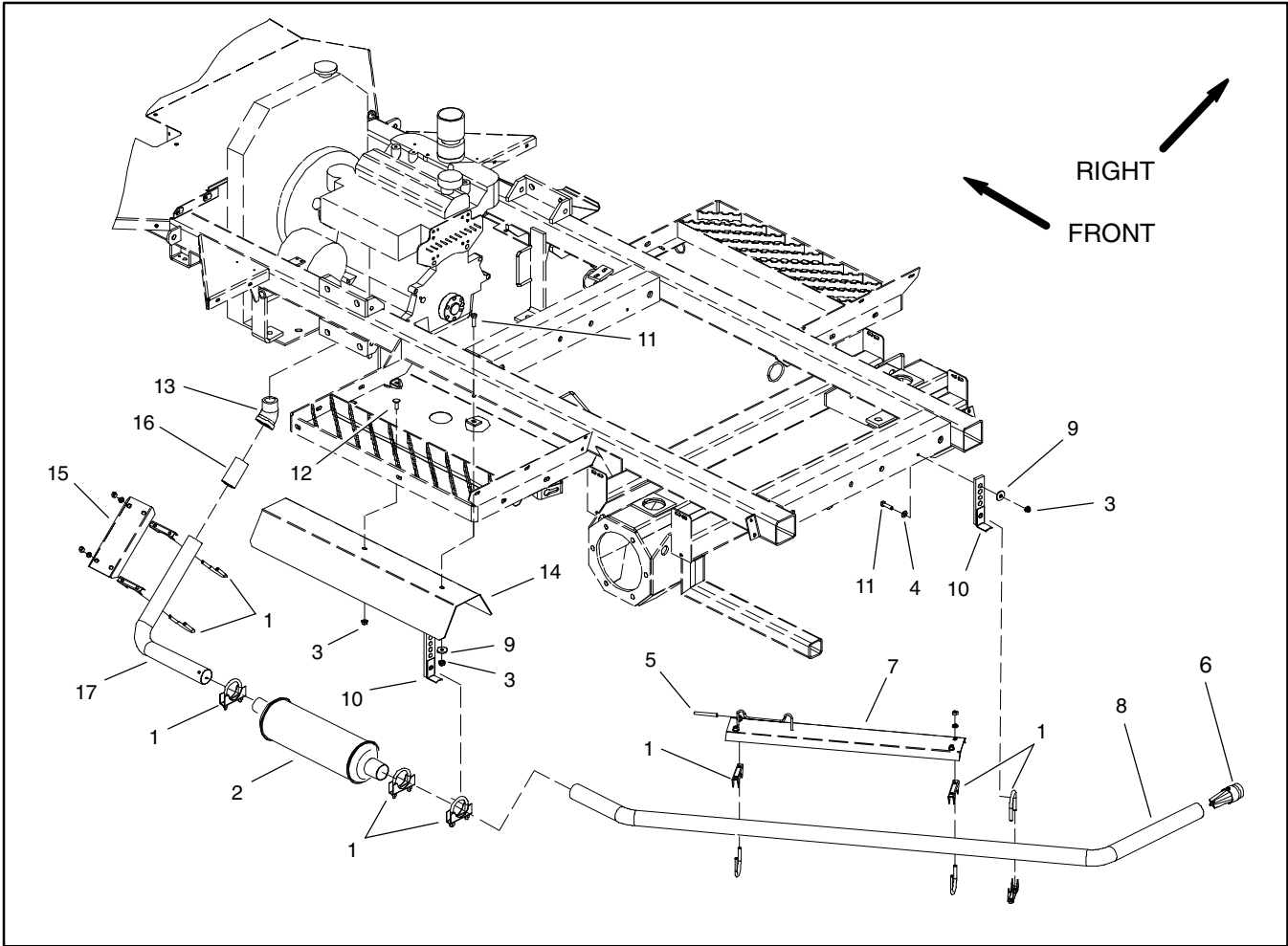
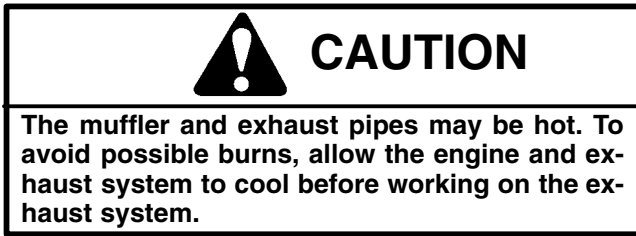

Figure 13

- |                   |                         |                  |
|-------------------|-------------------------|------------------|
| 1. Muffer clamp   | 7. Tailpipe shield      | 13. Elbow        |
| 2. Muffler        | 8. Tailpipe             | 14. Heat shield  |
| 3. Flange nut     | 9. Flat washer          | 15. Heat shield  |
| 4. Flat washer    | 10. Exhaust pipe hanger | 16. Pipe nipple  |
| 5. Foil tape      | 11. Cap screw           | 17. Exhaust pipe |
| 6. Spark arrester | 12. Carriage bolt       |                  |

## Removal (Fig. 13)



1. Park machine on a level surface, stop engine, engage parking brake, and remove key from the ignition switch.
2. Remove the tailpipe section of the exhaust system:
  - A. Support muffler from below. Note position of hydraulic hose to left rear wheel motor in hose rest on top of tailpipe shield.
  - B. Loosen two (2) muffler clamps that secure tailpipe to tailpipe hangers. Loosen one (1) muffler clamp that secures tailpipe to muffler.
  - C. Remove tailpipe from muffler outlet and lower tailpipe from machine.
3. Loosen muffler clamp that secures muffler to exhaust pipe. Slide muffler from exhaust pipe and lower muffler from machine.
4. Loosen muffler clamp that secures exhaust pipe to pipe nipple. Slide exhaust pipe from pipe nipple and lower exhaust pipe from machine.
5. If needed, loosen and remove pipe nipple and elbow from engine exhaust manifold.

## Installation (Fig. 13)

1. If removed, install elbow and pipe nipple to engine exhaust manifold.

**IMPORTANT:** While installing exhaust system components to machine, tighten muffler clamps only enough to keep components in position. Fully tighten clamps after complete exhaust system has been installed to machine.

2. Slide exhaust pipe over pipe nipple. Hold in position with muffler clamp.

**NOTE:** Muffler inlet is offset and muffler outlet is centered.

3. Slide muffler clamp on exhaust pipe and slide muffler inlet (offset) onto exhaust pipe. Support muffler from below.
4. Slide two (2) muffler clamps on front end of tailpipe and one (1) clamp on back end.
5. Slide tailpipe to muffler outlet (centered). Position tailpipe to hangers with muffler clamps. Route hydraulic hose over hose rest on top of tailpipe shield.
6. Tighten all muffler clamps to secure exhaust system to machine.

# Engine

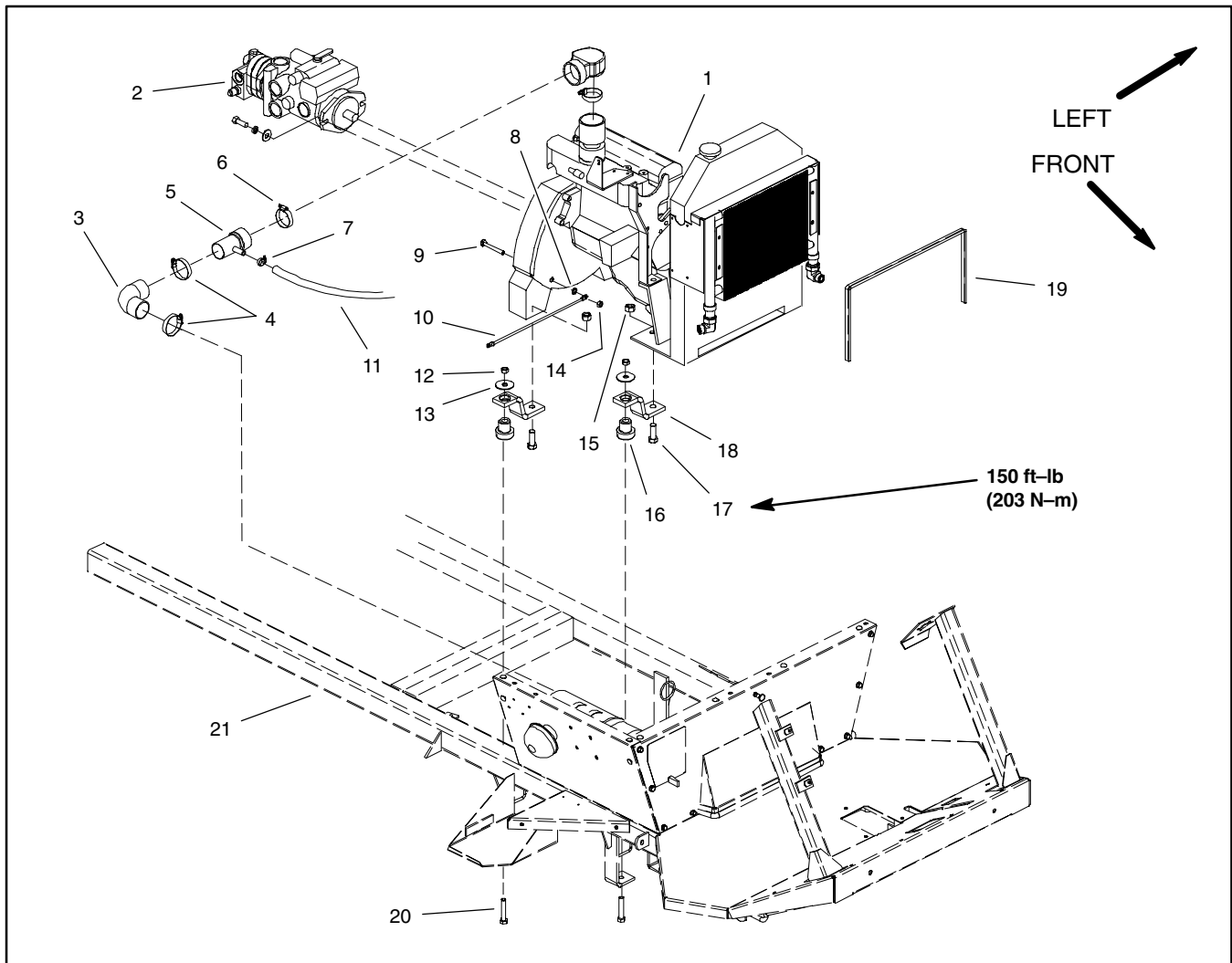



Figure 14

- |                            |                               |                             |
|----------------------------|-------------------------------|-----------------------------|
| 1. Engine assembly         | 8. Lock washer                | 15. Lock nut (4 used)       |
| 2. Hydraulic pump assembly | 9. Cap screw                  | 16. Motor mount (4 used)    |
| 3. Air cleaner elbow       | 10. Ground cable              | 17. Cap screw (4 used)      |
| 4. Hose clamp              | 11. Hose (to engine oil fill) | 18. Engine bracket (4 used) |
| 5. Intake tube             | 12. Lock nut (4 used)         | 19. Oil cooler shroud trim  |
| 6. Hose clamp              | 13. Washer (4 used)           | 20. Cap screw (4 used)      |
| 7. Hose clamp              | 14. Lock nut                  | 21. Machine frame           |

## Removal (Fig. 14)

1. Park machine on a level surface, stop engine, and remove key from the ignition switch. Raise machine to allow engine to be lowered from frame.
2. Disconnect negative (-) and then positive (+) battery cables at the battery.
3. Loosen hose clamps that secure air cleaner elbow and intake tube to air intake assembly. Remove air cleaner elbow and intake tube.



## CAUTION

**Do not open radiator cap or drain coolant if the radiator or engine is hot. Pressurized, hot coolant can escape and cause burns. Ethylene-glycol antifreeze is poisonous. Dispose of coolant properly, or store it in a properly labeled container away from children and pets.**

4. Drain coolant from the radiator into a suitable container (see Operator's Manual).



## CAUTION

Exhaust system components may be hot. To avoid possible burns, allow the exhaust system to cool before working on or near the muffler.

5. Remove exhaust system from engine (see Exhaust System Removal in this section).
6. Disconnect engine electrical connections. Position wires away from engine.

**NOTE:** Label all electrical leads for reassembly purposes.

A. Remove nut from electric starter motor solenoid stud (Fig. 15). Remove positive battery cable and cable to accessory solenoid from starter solenoid stud.

B. Unplug connectors from vacuum sensor module, fuse holder and ignition control module located under passenger seat (Fig. 16). Remove vacuum line from vacuum sensor.

C. Remove lock nut that secures ground cable to bell housing on engine (Fig. 17). Locate and retrieve lock washer located between cable end and bell housing.

D. Remove caps from studs on engine electrical panel that is attached to engine bell housing. Unscrew nut on each stud and remove machine harness wires from engine electrical panel (Fig. 18):

- Black harness wire from GD terminal
- Red wire from BAT terminal
- Double yellow/red from IGN terminal
- Red/blue from ST terminal
- Red/white from TEMP terminal
- White/red from PRES terminal
- Single yellow/red from ALT terminal

7. Clamp fuel hose between the fuel tank and fuel filter to prevent leakage (Fig. 19). Disconnect fuel hose from the fuel filter. Position disconnected fuel hose away from engine.

**IMPORTANT:** Support hydraulic pump assembly to prevent it from falling and being damaged.

8. Remove hydraulic pump assembly from engine (see Pump Assembly in Service and Repairs section of Chapter 4 – Hydraulic System).

9. Clean oil cooler fittings to prevent hydraulic system contamination. Remove hydraulic hose from right side (passenger) oil cooler fitting. Remove tee fitting from left side (operator) oil cooler fitting.

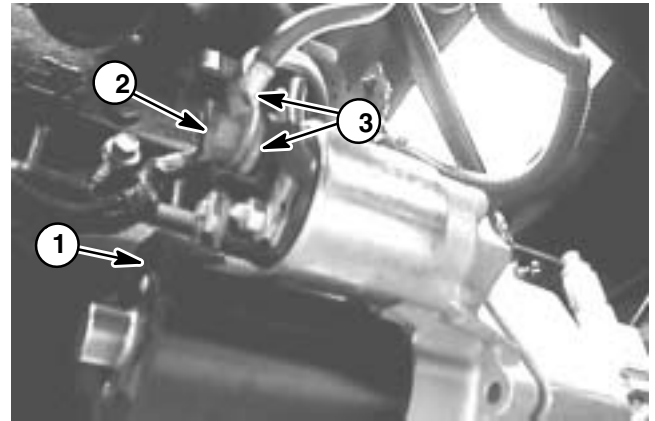

Figure 15

1. Starter motor
2. Solenoid stud
3. Cables

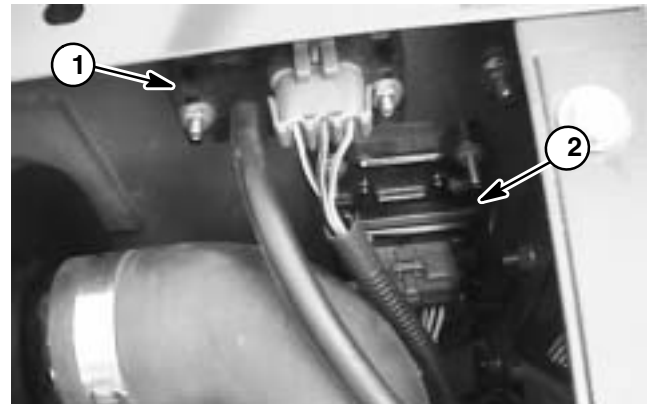

Figure 16

1. Vacuum switch
2. Ignition control module

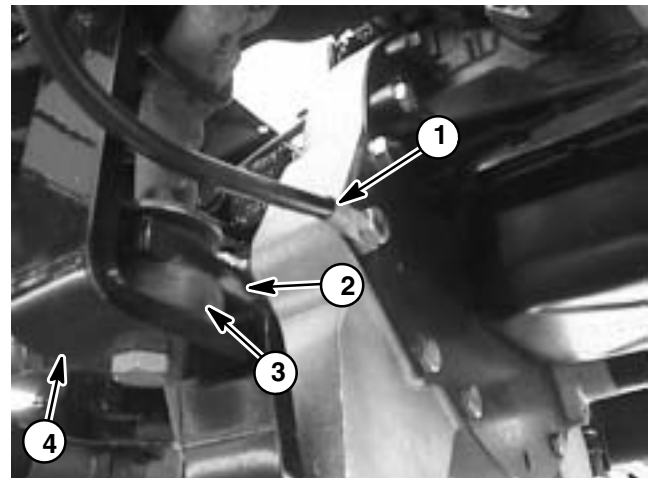

Figure 17

1. Ground cable
2. Engine bracket
3. Motor mount
4. Frame

10. Remove throttle and choke cables from engine (Fig. 20).

- A. Loosen and remove cap screw and nut that secure end of throttle cable to governor lever.
- B. Loosen and remove screw, flat washer and flange nut that secure throttle cable clamp to control bracket.
- C. Loosen screw that secures choke cable to choke lever swivel.
- D. Loosen screw with washer that secures choke cable to carburetor.
- E. Position cables away from the engine.

11. Note location of any cable ties used to secure the wiring harness, fuel lines, or hydraulic hoses to the engine assembly. Remove cable ties attached to engine assembly.

**IMPORTANT: Support engine assembly from below to prevent it from falling and being damaged.**

12. Using a hoist or lift, raise engine slightly to allow easier removal of fasteners that secure engine to frame. Support engine to prevent it from shifting during removal.

13. Remove lock nuts, washers, and cap screws securing the engine brackets and motor mounts to the machine frame (Fig. 17).

14. Loosen lock nuts and cap screws that secure engine brackets to engine. Position engine brackets to allow engine to be lowered from machine.

**IMPORTANT: Make sure not to damage the engine, fuel hoses, hydraulic lines, electrical harness, or other parts while removing the engine assembly.**

15. Using a hoist or lift, slowly lower engine from the machine.

16. If necessary, remove engine brackets from the engine.

**Installation (Fig. 14)**

- 1. Locate machine on a level surface with key removed from the ignition switch. Chock wheels to keep the machine from moving.
- 2. Make sure that all parts removed from the engine during maintenance or rebuilding are reinstalled to the engine.
- 3. If engine brackets were removed from engine, install brackets to engine with cap screws and lock nuts. Do not fully tighten fasteners.

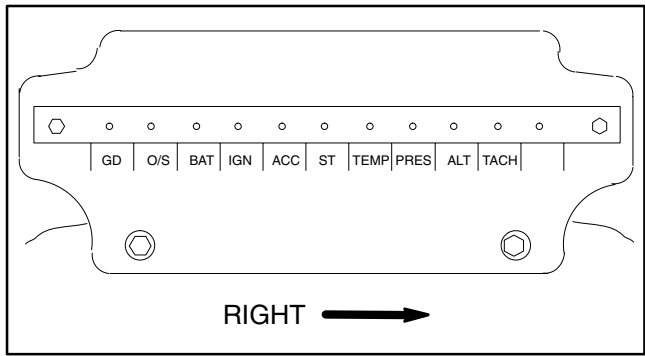

Figure 18

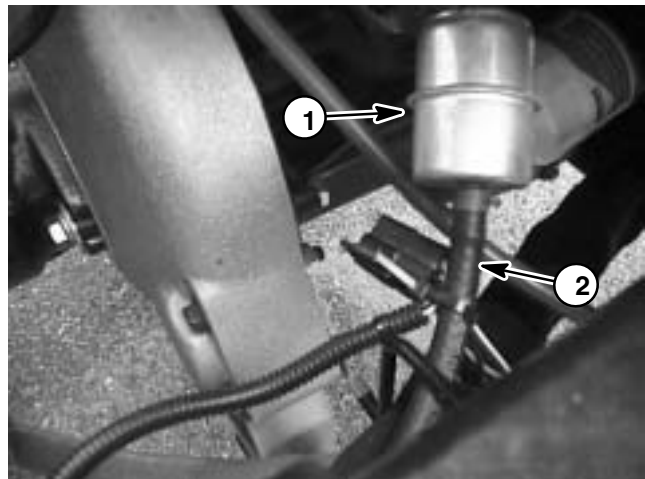

Figure 19

- 1. Fuel filter
- 2. Fuel hose (from tank)

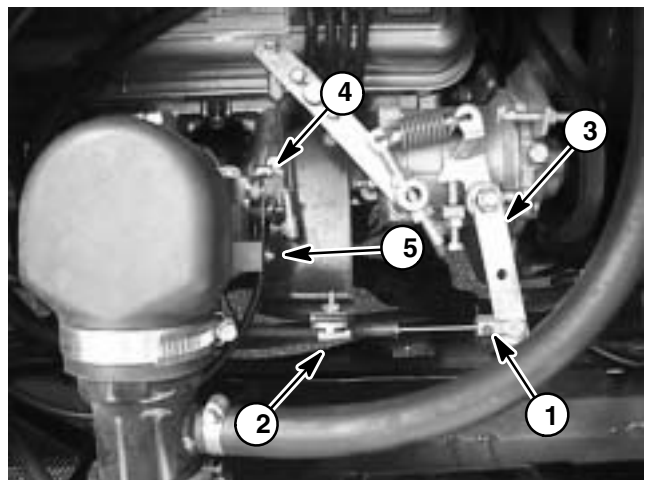

Figure 20

- 1. Throttle cable
- 2. Throttle cable clamp
- 3. Governor lever
- 4. Choke lever swivel
- 5. Screw w/washer



4. Insert motor mounts from below into engine brackets. Position engine brackets to allow engine to be raised into machine.

**IMPORTANT: Support engine assembly from below to prevent it from falling and being damaged during installation.**

**IMPORTANT: Make sure not to damage the engine, fuel hoses, hydraulic lines, electrical harness, or other parts while installing the engine assembly.**

5. Using a hoist or lift, slowly raise engine assembly from under machine and position to frame. Insert cap screws through frame, motor mounts and engine brackets from below (Fig. 17). Install washers and lock nuts on cap screws. Do not fully tighten lock nuts.

6. Push engine assembly forward to make sure trim on oil cooler shroud is compressed. Tighten engine brackets to engine first: torque lock nuts to 150 ft–lb (203 N–m). Then tighten lock nuts to secure engine brackets to frame.

7. Reconnect electrical connections.

A. Install positive battery cable and accessory solenoid cable onto starter solenoid stud (Fig. 15). Secure cables to stud with nut.

B. Install harness connectors to vacuum sensor module, fuse holder and ignition control module located under passenger seat (Fig. 16). Install vacuum line to vacuum sensor.

C. Position lock washer between ground cable end and bell housing. Secure ground cable to engine bell housing with lock nut (Fig. 17).

D. Position machine wire harness to engine bell housing. Install machine harness wires to engine electrical panel (Fig. 18):

Black harness wire to GD terminal

Red wire to BAT terminal

Double yellow/red to IGN terminal

Red/blue to ST terminal

Red/white to TEMP terminal

White/red to PRES terminal

Single yellow/red to ALT terminal

Secure harness wire connectors with nuts and install caps to studs.

8. Connect fuel hose to the fuel filter (Fig. 19).

9. Install choke cable to choke lever swivel (Fig. 20). Secure choke cable to carburetor with washer and screw. Check choke cable adjustment (see Adjust Choke Cable in the Adjustments Section of this Chapter).

10. Reconnect throttle cable to engine (Fig. 20).

A. Position throttle cable end to the engine governor lever. Secure cable end with cap screw and nut.

B. Install screw, flat washer and flange nut that secure throttle cable clamp to control bracket. Tighten flange nut.

**IMPORTANT: During installation, support hydraulic pump assembly to prevent it from falling and being damaged.**

11. Install hydraulic pump assembly to engine (see Pump Assembly in Service and Repairs section of Chapter 4 – Hydraulic System).

12. Install hydraulic hoses to oil cooler (see Oil Cooler in Service and Repairs section of Chapter 4 – Hydraulic Systems).

**IMPORTANT: Any leaks in the air intake system will cause serious engine damage. Make sure that all air cleaner components are in good condition and are properly secured during reassembly.**

13. Install air cleaner elbow and intake tube. Make sure that hose clamps are properly tightened.

14. Install exhaust system (see Exhaust System Installation in this section).

15. Install cable ties to secure the wiring harness, fuel lines, and hydraulic hoses to the engine assembly using notes taken during engine removal.

16. Properly fill the radiator with coolant (see Operator's Manual).

17. Check engine oil level (see Operator's Manual).

18. Connect positive (+) and then negative (–) battery cables to the battery.

19. Check position of wires, fuel lines, hydraulic hoses, and cables for proper clearance with rotating, high temperature, and moving components.

20. Start engine and check for proper operation. Check all hose connections for leaks. Check engine speed and adjust if needed (see Adjust Engine Speed in the Adjustments Section of this Chapter).

## Crankshaft Pulley Installation (Fig. 21)

1. Insert locking rings into crankshaft pulley.

**NOTE:** Outside locking rings have tapered I.D. and flat O.D. Inside locking rings have flat I.D. and tapered O.D.

A. Install first outside ring with the flat edge of the ring seated against small internal shoulder of pulley (Fig. 22).

B. Install inside ring, mating taper to taper with the installed outside ring.

C. Install the second outside ring with the flat edge of the ring against the installed inside ring.

D. Rotate the three installed rings so end gaps are aligned with the pulley key slot.

2. Install woodruff key into engine crankshaft key slot.

3. Align pulley key slot with woodruff key. Install pulley approximately 1/4" (6.4 mm) onto crankshaft.

4. Insert final inside ring, mating taper to taper with the second installed outside ring.

5. Insert cap screw through flat washer and compression washer. Thread cap screw into crankshaft.

6. Draw pulley onto engine crankshaft by tightening cap screw. Resistance will be felt as crankshaft passes through the locking rings.

7. Torque cap screw from 40 to 44 ft-lb (54.2 to 59.7 N-m). Check pulley alignment between crankshaft and water pump pulleys to assure correct installation.

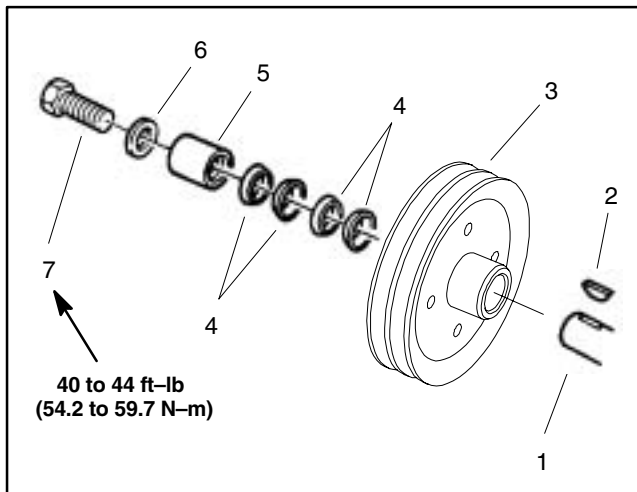

Figure 21

- |                      |                       |
|----------------------|-----------------------|
| 1. Engine crankshaft | 5. Compression washer |
| 2. Woodruff key      | 6. Flat washer        |
| 3. Pulley            | 7. Cap screw          |
| 4. Locking ring      |                       |

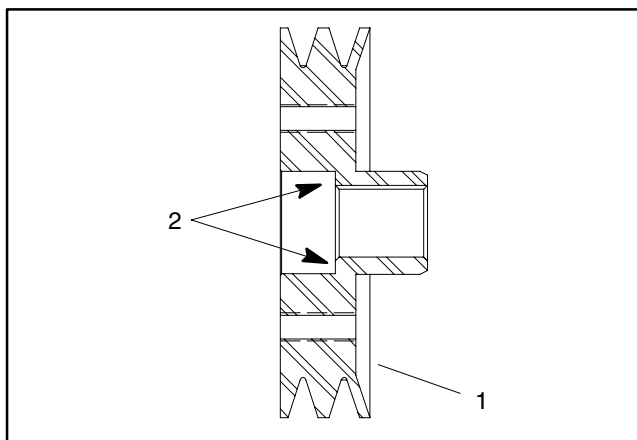

Figure 22

- |           |                      |
|-----------|----------------------|
| 1. Pulley | 2. Internal shoulder |
|-----------|----------------------|



# Hydraulic System

Hydraulic System

## Table of Contents

SPECIFICATIONS .....	3	SERVICE AND REPAIRS .....	27
GENERAL INFORMATION .....	4	General Precautions for Removing and Installing	
Hydraulic Hoses .....	4	Hydraulic System Components .....	27
Hydraulic Fitting Installation .....	4	Check Hydraulic Lines and Hoses .....	27
Towing Sprayer .....	6	Flush Hydraulic System .....	28
Check Hydraulic Fluid .....	6	Charge Hydraulic System .....	29
HYDRAULIC SCHEMATIC .....	8	Gear Pump .....	30
HYDRAULIC FLOW CIRCUITS .....	9	Gear Pump Service .....	32
Traction Circuit .....	9	Piston (Traction) Pump .....	34
Steering Circuit .....	10	Piston (Traction) Pump Service .....	36
Spray Pump Drive Circuit .....	11	Manual Servo Control Assembly .....	37
SPECIAL TOOLS .....	12	Wheel Motors .....	38
Hydraulic Pressure Test Kit .....	12	Wheel Motor Service .....	40
Hydraulic Tester (Pressure and Flow) .....	12	Spray Pump Drive Motor .....	42
Hydraulic Test Fitting Kit .....	13	Spray Pump Drive Motor Service .....	44
TROUBLESHOOTING .....	14	Relief Valve .....	45
TESTING .....	16	Pulse Width Modulated (PWM) Valve .....	46
Traction Circuit Charge Pressure Test .....	17	Steering Control Valve .....	48
Traction Circuit Relief Pressure Test .....	18	Steering Control Valve Service .....	50
Gear Pump Flow Test .....	19	Steering Cylinder .....	52
Steering Circuit Relief Pressure Test .....	20	Steering Cylinder Service .....	54
Steering Control Valve and Steering		Oil Cooler .....	56
Cylinder Test .....	21	Hydraulic Reservoir .....	58
Spray Pump Drive Circuit Relief Pressure Test ..	22	EATON MODEL 26000 SINGLE GEAR PUMP REPAIR	
Wheel Motor Efficiency: Case Drain Test .....	23	INFORMATION	
Pulse Width Modulated (PWM) Valve Flow Test ..	24	EATON MODEL 72400 SERVO CONTROLLED PIS-	
ADJUSTMENTS .....	25	TON PUMP REPAIR INFORMATION	
Adjust Traction Pedal for Neutral .....	25	EATON MODEL 74318 and 74348 PISTON MOTORS:	
Adjust Relief Valve .....	25	FIXED DISPLACEMENT, VALVE PLATE DESIGN	
		REPAIR INFORMATION	
		PARKER TORQLINK™ SERVICE PROCEDURE	

This page is intentionally blank.

# Specifications

Item	Description
Piston (Traction) Pump System Relief Pressure: Forward System Relief Pressure: Reverse Charge Pressure	Variable displacement piston pump 4000 PSI (276 bar) 4000 PSI (276 bar) 250 to 300 PSI (17 to 21 bar)
Gear Pump Steering Circuit Relief Pressure Spray Pump Circuit Relief Pressure	Single section, positive displacement gear pump 1000 PSI (69 bar) 1500 PSI (103 bar)
Rear Wheel Motors	Fixed displacement piston motor
Spray Pump Motor	Orbital rotor motor
Hydraulic Filter	10 Micron spin-on cartridge type
Hydraulic Reservoir	10.6 gal. (40 l)
Hydraulic Oil	See Operator's Manual

# General Information

## Hydraulic Hoses

Hydraulic hoses are subject to extreme conditions such as pressure differentials during operation and exposure to weather, sun, chemicals, very warm storage conditions, or mishandling during operation and maintenance. These conditions can cause damage or premature deterioration. Some hoses are more susceptible to these conditions than others. Inspect the hoses frequently for signs of deterioration or damage.

When replacing a hydraulic hose, be sure that the hose is straight (not twisted) before tightening the fittings. This can be done by observing the imprint on the hose. Use two wrenches; hold the hose straight with one wrench and tighten the hose swivel nut onto the fitting with the other wrench.

WARNING

**Before disconnecting or performing any work on hydraulic system, relieve all pressure in system. Stop engine and rotate the steering wheel.**

**Keep body and hands away from pin hole leaks or nozzles that eject hydraulic fluid under high pressure. Use paper or cardboard, not hands, to search for leaks. Hydraulic fluid escaping under pressure can have sufficient force to penetrate the skin and cause serious injury. If fluid is injected into the skin, it must be surgically removed within a few hours by a doctor familiar with this type of injury. Gangrene may result from such an injury.**

## Hydraulic Fitting Installation

### O-Ring Face Seal

1. Make sure both threads and sealing surfaces are free of burrs, nicks, scratches, or any foreign material.
2. Make sure the O-ring is installed and properly seated in the groove. It is recommended that the O-ring be replaced any time the connection is opened.
3. Lubricate the O-ring with a light coating of oil.
4. Put the tube and nut squarely into position on the face seal end of the fitting and tighten the nut until finger tight.
5. Mark the nut and fitting body. Hold the body with a wrench. Use another wrench to tighten the nut to the correct Flats From Finger Tight (F.F.T.). The markings on the nut and fitting body will verify that the connection has been tightened.

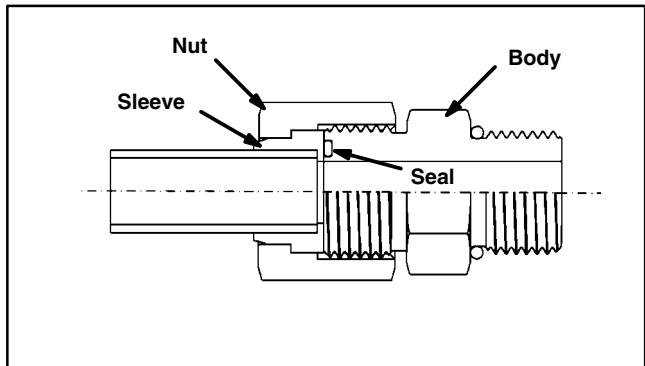

Figure 1

Size	F.F.T.
4 (1/4 in. nominal hose or tubing)	0.75 ± 0.25
6 (3/8 in.)	0.75 ± 0.25
8 (1/2 in.)	0.75 ± 0.25
10 (5/8 in.)	1.00 ± 0.25
12 (3/4 in.)	0.75 ± 0.25
16 (1 in.)	0.75 ± 0.25

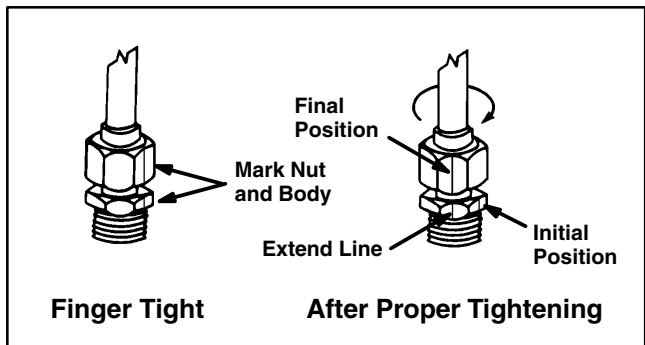

Figure 2

### SAE Straight Thread O-Ring Port – Non-adjustable

1. Make sure both threads and sealing surfaces are free of burrs, nicks, scratches, or any foreign material.
2. Always replace the O-ring seal when this type of fitting shows signs of leakage.
3. Lubricate the O-ring with a light coating of oil.
4. Install the fitting into the port and tighten it down full length until finger tight.
5. Tighten the fitting to the correct Flats From Finger Tight (F.F.F.T.).

Size	F.F.F.T.
4 (1/4 in. nominal hose or tubing)	1.00 ± 0.25
6 (3/8 in.)	1.50 ± 0.25
8 (1/2 in.)	1.50 ± 0.25
10 (5/8 in.)	1.50 ± 0.25
12 (3/4 in.)	1.50 ± 0.25
16 (1 in.)	1.50 ± 0.25

**NOTE:** Installation torque values for non-adjustable fittings are listed in Figure 4. These torque values should **only** be used when a fitting can be accessed with a socket. Use of an offset wrench (e.g. crowfoot wrench) will affect torque wrench accuracy and should not be used.

### SAE Straight Thread O-Ring Port – Adjustable

1. Make sure both threads and sealing surfaces are free of burrs, nicks, scratches, or any foreign material.
2. Always replace the O-ring seal when this type of fitting shows signs of leakage.
3. Lubricate the O-ring with a light coating of oil.
4. Turn back the jam nut as far as possible. Make sure the back up washer is not loose and is pushed up as far as possible (Step 1).
5. Install the fitting into the port and tighten finger tight until the washer contacts the face of the port (Step 2).
6. To put the fitting in the desired position, unscrew it by the required amount, but no more than one full turn (Step 3).
7. Hold the fitting in the desired position with a wrench and turn the jam nut with another wrench to the correct Flats From Finger Tight (F.F.F.T.) (Step 4).

Size	F.F.F.T.
4 (1/4 in. nominal hose or tubing)	1.00 ± 0.25
6 (3/8 in.)	1.50 ± 0.25
8 (1/2 in.)	1.50 ± 0.25
10 (5/8 in.)	1.50 ± 0.25
12 (3/4 in.)	1.50 ± 0.25
16 (1 in.)	1.50 ± 0.25

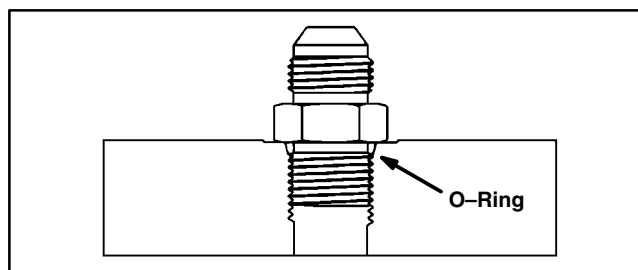

Figure 3

Fitting Size	Installation Torque
4	9–10 ft-lb (12–13 N-m)
6	20–21 ft-lb (27–28 N-m)
8	35–37 ft-lb (47–50 N-m)
10	60–66 ft-lb (81–89 N-m)
12	81–87 ft-lb (110–117 N-m)
16	121–131 ft-lb (164–177 N-m)

Figure 4

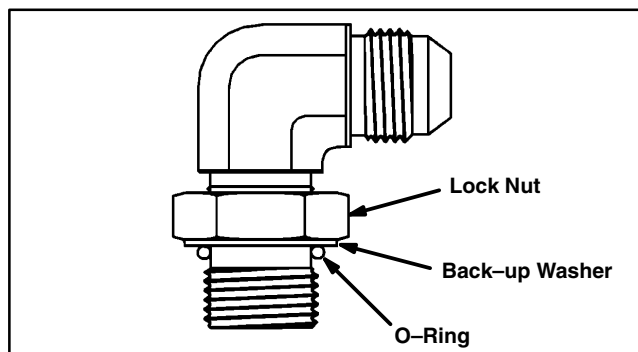

Figure 5

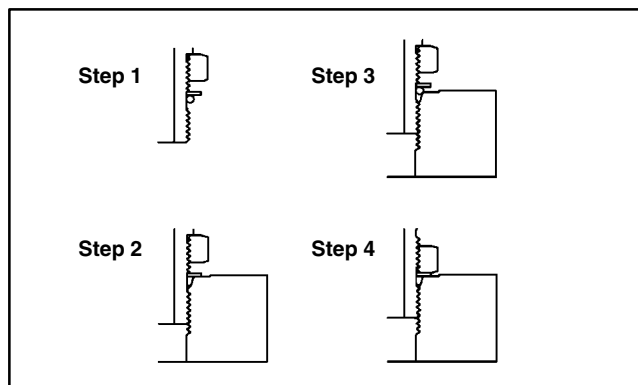

Figure 6

---

## Towing Sprayer

**IMPORTANT:** If towing limits are exceeded, severe damage to the piston (traction) pump may occur.

If it becomes necessary to tow (or push) the machine, tow (or push) at a speed **below 3 mph (4.8 kph)**. The piston (traction) pump is equipped with a by-pass valve that needs to be turned 90° for towing (or pushing). See Operator's Manual for Towing Procedures.

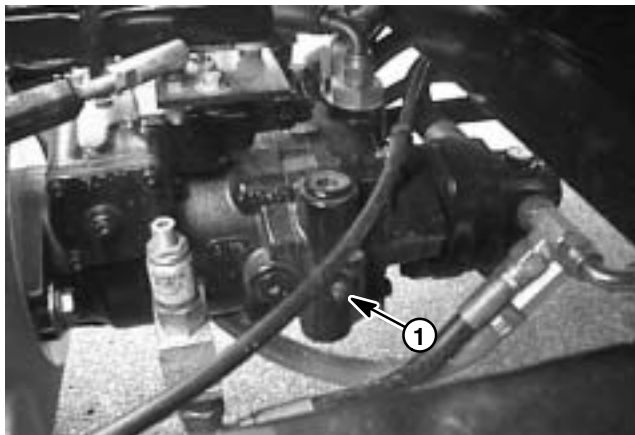

Figure 7

1. By-pass valve location

---

## Check Hydraulic Fluid

The Multi Pro 5600 hydraulic system is designed to operate on anti-wear hydraulic fluid. The reservoir holds approximately 10.6 gallons (40 liters) of hydraulic fluid. **Check level of hydraulic fluid daily.** See Operator's Manual for fluid level checking procedure and hydraulic oil recommendations.

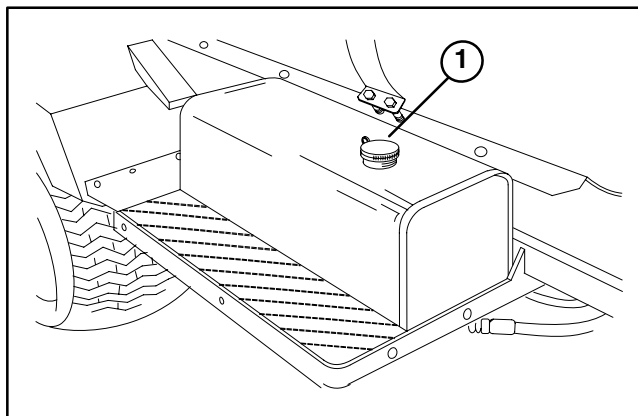

Figure 8

1. Hydraulic reservoir cap



This page is intentionally blank.

# Hydraulic Schematic

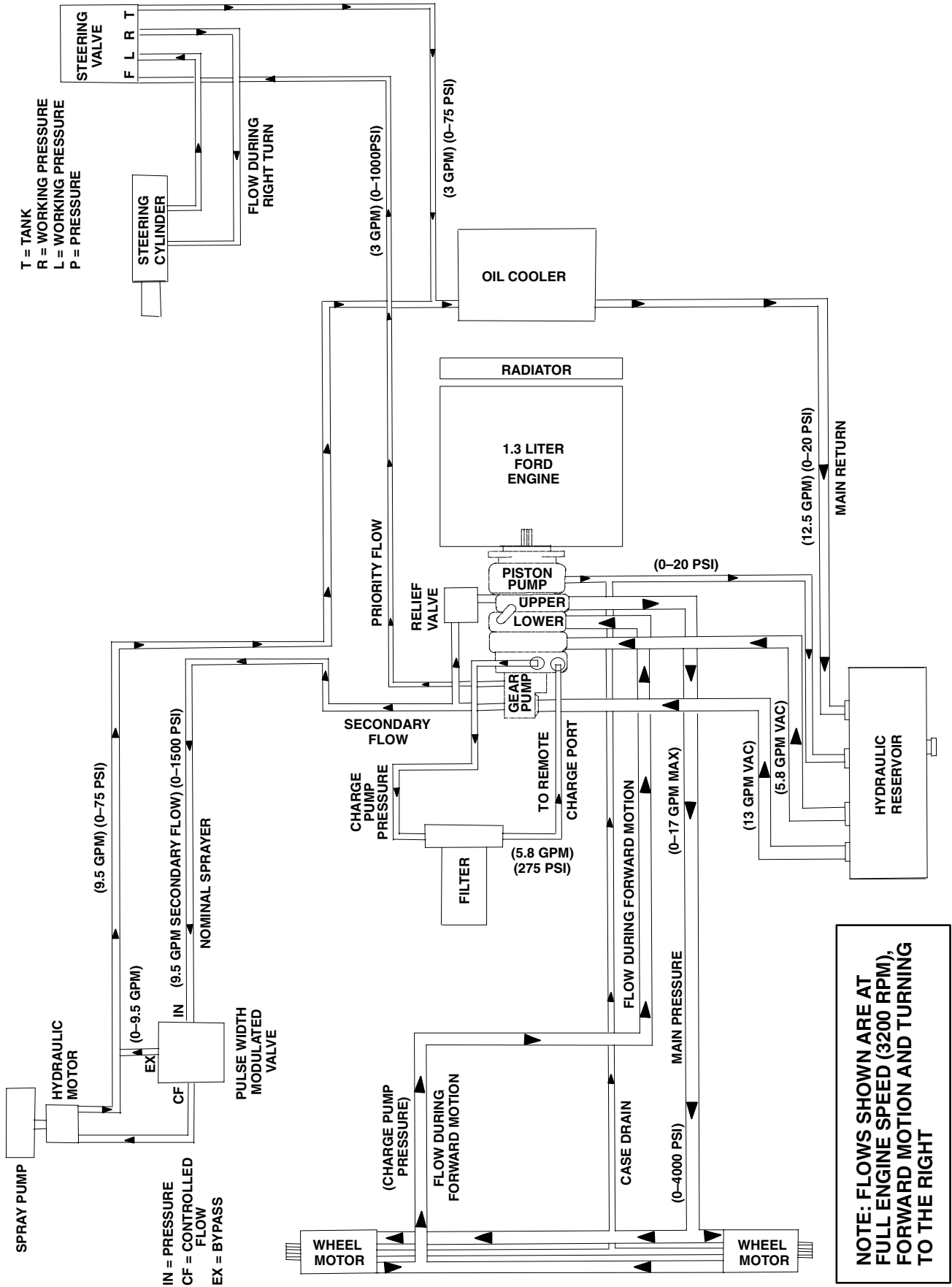

# Hydraulic Flow Circuits

---

## Traction Circuit

The traction circuit piston pump is a variable displacement pump that is directly coupled to the engine flywheel. Pushing the top of the traction pedal rotates the pump swash plate to create a flow of oil for forward machine movement. Pushing the bottom of the traction pedal rotates the pump swash plate to cause oil flow for reverse machine movement. This oil is directed to the rear wheel motors. Operating pressure on the high pressure side of the closed traction circuit loop is determined by the amount of load developed at the fixed displacement wheel motors. As the load increases, circuit pressure can increase to relief valve settings: 4000 PSI in either forward or reverse. If pressure exceeds the relief setting, oil flows through the relief valve to the low pressure side of the closed loop circuit.

Traction circuit pressure (forward or reverse) can be measured by installing a tee fitting and gauge into the traction system hydraulic lines.

The piston (traction) pump and wheel motors use a small amount of hydraulic oil for internal lubrication. Oil is designed to leak across pump and motor parts into the case drain. This leakage results in the loss of hydraulic oil from the closed loop traction circuit that must be replaced.

The piston (traction) pump incorporates a charge pump that provides make-up oil for the traction circuit. This gerotor gear pump is driven by the piston pump drive shaft. It provides a constant supply of charge oil to the traction circuit to make up for oil that is lost due to internal leakage in the piston pump and wheel motors.

Charge pump flow is directed through the oil filter and to the low pressure side of the closed loop traction circuit. Pressure in the charge circuit is limited by a relief valve located in the charge plate adapter on the rear of the piston pump. Charge pump pressure can be measured at the auxiliary test port on the side of the piston pump.

## Steering Circuit

A single section gear pump is coupled to the piston (traction) pump. The gear pump supplies hydraulic flow to the steering control valve and the spray pump drive hydraulic motor. Pump hydraulic flow is delivered to the two circuits through a flow divider with the steering circuit having priority. The gear pump takes its suction from the hydraulic reservoir. Steering circuit pressure is limited by a relief valve located in the gear pump.

The steering control valve includes a check valve that allows steering operation when the engine is not running. Steering wheel rotation with the engine off causes oil flow from the steering control gerotor. The check valve opens in this situation to allow oil flow from the steering control to the steering cylinder in a closed loop.

Hydraulic flow and pressure to the steering control valve can be monitored at the outlet of the gear pump.

With the steering wheel in the neutral position and the engine running, gear pump flow enters the steering control valve (port P) and goes through the steering control spool valve, by-passing the rotary meter (V1) and steering cylinder. Flow leaves the control valve (port T), to the oil cooler, and returns to the hydraulic oil reservoir.

### Left Turn

When a left turn is made with the engine running, the turning of the steering wheel positions the spool valve so

that flow goes through the top of the spool. Flow entering the steering control valve from the gear pump goes through the spool and is routed through the rotary meter (V1) and out the L port. Pressure extends the steering cylinder piston for a left turn. The rotary meter ensures that the oil flow to the cylinder is proportional to the amount of the turning on the steering wheel. Fluid leaving the cylinder flows back through the spool valve, then to the oil cooler and returns to the reservoir.

The steering control valve returns to the neutral position when turning is completed.

### Right Turn

When a right turn is made with the engine running, the turning of the steering wheel positions the spool valve so that flow goes through the bottom of the spool. Flow entering the steering control valve from the gear pump goes through the spool and is routed through rotary meter (V1) but goes out port R. Pressure contracts the steering cylinder piston for a right turn. The rotary meter ensures that the oil flow to the cylinder is proportional to the amount of the turning on the steering wheel. Fluid leaving the cylinder flows back through the spool valve, then to the oil cooler and returns to the reservoir.

The steering control valve returns to the neutral position when turning is completed.

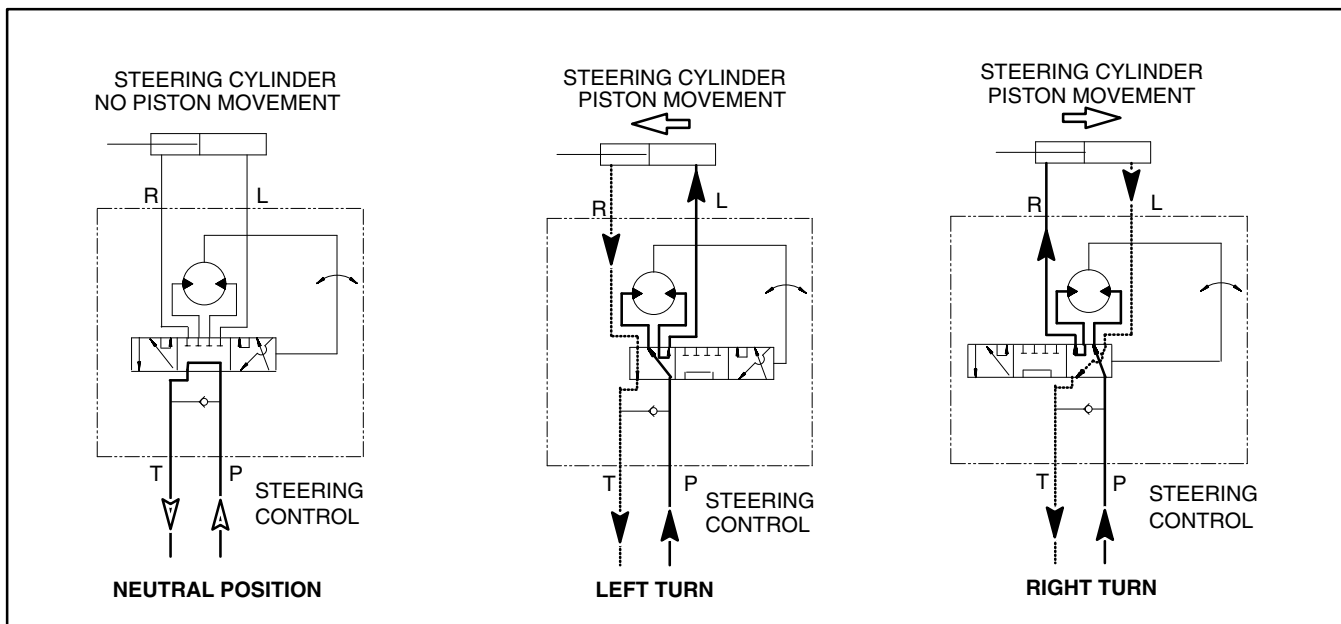

Figure 9

---

## Spray Pump Drive Circuit

A single section gear pump is coupled directly to the piston (traction) pump. The gear pump supplies hydraulic flow to the steering control valve and the spray pump drive hydraulic motor. Gear pump hydraulic flow is delivered to the two circuits through a flow divider with the steering circuit having priority. The gear pump takes its suction from the hydraulic reservoir. Spray pump drive circuit pressure is limited by an adjustable relief valve located on the outside of the piston (traction) pump.

Spray pump drive circuit hydraulic flow and pressure can be monitored at the outlet of the gear pump.

Hydraulic flow control for the spray pump drive hydraulic motor is completed by the Pulse Width Modulated (PWM) Valve. The PWM Valve consists of an electric solenoid valve that allows the operator to adjust hydraulic flow to the spray pump motor. The spray pump on/off and application rate (increase/decrease) switches are used to adjust electrical current to the PWM Valve solenoid.

With the engine running and the spray pump switch in the OFF position, the solenoid valve in the PWM Valve is not energized. All gear pump flow to the PWM Valve is directed out the EX port of the PWM Valve, to the oil cooler, and returns to the hydraulic oil reservoir. The spray pump hydraulic motor receives no hydraulic flow so the spray system pump is not rotated and no spray system flow is available.

With the engine running and the spray pump switch in the ON position, the solenoid valve in the PWM Valve is energized. Based on available current (mA) from the spray pump application rate (increase/decrease) switch, the solenoid spool valve in the PWM Valve directs some gear pump flow out the CF port to the spray pump hydraulic motor. This hydraulic flow causes the motor to rotate the spray system pump for spray system operation. Gear pump hydraulic flow in excess of PWM solenoid spool valve setting is directed out the EX port of the PWM Valve, to the oil cooler, and returns to the hydraulic oil reservoir.

The spray pump application rate (increase/decrease) switch allows the operator to adjust electrical current to the PWM Valve solenoid. Higher current (rate increase) to the PWM Valve solenoid increases hydraulic flow to the spray pump motor and results in a higher spray pump speed with more spray system output/pressure. Lower current (rate decrease) to the PWM Valve solenoid decreases hydraulic flow to the spray pump motor and results in a lower spray pump speed with less spray system output/pressure.

**NOTE:** Correct operation of the PWM Valve depends on precision manufacturer's assembly and adjustment. No disassembly or adjustment of the PWM Valve is recommended.

# Special Tools

Order these special tools from your Toro Distributor.

---

## Hydraulic Pressure Test Kit

Toro Part Number: **TOR47009**

Use to take various pressure readings for diagnostic tests. Quick disconnect fittings provided attach directly to mating fittings on machine test ports without tools. A high pressure hose is provided for remote readings. Contains one each: 1000 PSI (70 Bar), 5000 PSI (350 Bar) and 10000 PSI (700 Bar) gauges. Use gauges as recommended in Testing section of this chapter.



Figure 10

---

## Hydraulic Tester (Pressure and Flow)

Toro Part Number: **TOR214678**

This tester requires O-ring Face Seal (ORFS) adapter fittings for use on this machine (see Hydraulic Test Fitting Kit - TOR4079 in this section).

1. **INLET HOSE:** Hose connected from the system circuit to the inlet side of the hydraulic tester.
2. **LOAD VALVE:** A simulated working load is created in the circuit by turning the valve to restrict flow.
3. **LOW PRESSURE GAUGE:** Low range gauge to provide accurate reading at low pressure: 0 to 1000 PSI.

A protector valve cuts out when pressure is about to exceed the normal range for the gauge. The cutout pressure is adjustable.

4. **HIGH PRESSURE GAUGE:** High range gauge which accommodates pressures beyond the capacity of the low pressure gauge: 0 to 5,000 PSI.
5. **FLOW METER:** This meter measures actual oil flow in the operating circuit with a gauge rated at 15 GPM.
6. **OUTLET HOSE:** A hose from the outlet side of the hydraulic tester connects to the hydraulic system circuit.



Figure 11

## O-Ring Kit

Toro Part Number: **16-3799**

The kit includes O-rings in a variety of sizes for face seal and port seal hydraulic connections. It is recommended that O-rings be replaced whenever a hydraulic connection is loosened.



Figure 12

## Hydraulic Test Fitting Kit

Toro Part Number: **TOR4079**

This kit includes a variety of O-ring Face Seal fittings to enable connection of test gauges to the hydraulic system.

The kit includes: tee's, unions, reducers, plugs, caps, and test fittings.







TORO TEST FITTING KIT (NO. TOR4079)			
FITTING	TOOL NUMBER	FITTING	TOOL NUMBER
	<b>Swivel Nut Run Tee (2 ea.)</b> Size Toro No. No. 4 TOR4079-3 No. 6 TOR4079-12 No. 8 TOR4079-4 No. 10 TOR4079-5		<b>Union (1 ea.)</b> Size Toro No. No. 6 to No. 8 TOR4079-8 No. 10 to No. 8 TOR4079-2 No. 8 to No. 8 TOR4079-9
	<b>Plug (2 ea.)</b> Size Toro No. No. 4 TOR4079-13 No. 6 TOR4079-14 No. 8 TOR4079-15 No. 10 TOR4079-16		<b>Reducer (1 ea.)</b> Size Toro No. No. 10 to No. 8 TOR4079-7 No. 12 to No. 8 TOR4079-6
	<b>Cap (2 ea.)</b> Size Toro No. No. 4 TOR4079-17 No. 6 TOR4079-18 No. 8 TOR4079-19 No. 10 TOR4079-20		<b>Test Cap Fitting (2 ea.)</b> Size Toro No. No. 4 TOR4079-10 No. 6 TOR4079-11 No. 8 TOR4079-21 No. 10 TOR4079-1
			<b>Test Fitting (2 ea.)</b> Size Toro No. 7/16-20 ORB TOR4079-22 1/8" Pipe Thd. TOR4079-23

Figure 13

Hydraulic System

# Troubleshooting

The cause of an improperly functioning hydraulic system is best diagnosed with the use of proper testing equipment and a thorough understanding of the complete hydraulic system.

A hydraulic system with an excessive increase in heat or noise has a potential for failure. Should either of these conditions be noticed, immediately stop the machine, turn off the engine, locate the cause of the trouble, and correct it before allowing the machine to be used again.

Continued use of an improperly functioning hydraulic system could lead to extensive internal component damage.

The chart that follows contains information to assist in troubleshooting. There may possibly be more than one cause for a machine malfunction.

Refer to the Testing section of this Chapter for precautions and specific test procedures.

Problem	Possible Cause
Hydraulic oil leaks.	Hydraulic fitting(s) or hose(s) are loose or damaged. O-ring(s) or seal(s) are missing or damaged.
Foaming hydraulic fluid.	Oil level in reservoir is incorrect. Hydraulic system has wrong kind of oil. Piston and/or gear pump suction line has an air leak. Water in hydraulic system.
Hydraulic system operates too slowly.	Oil level in reservoir is incorrect. Hydraulic hose is kinked. Oil is contaminated or incorrect viscosity. Brakes are engaged or sticking. Piston pump bypass valve is open or damaged. Hydraulic oil cooling system is not operating properly. Charge pressure is low. Traction circuit pressure is incorrect. Wheel motor(s) or spool pump motor are worn or damaged. Gear pump or piston (traction) pump is worn or damaged.
Machine operates in one direction only.	Traction control linkage is faulty. System charge check valve and/or system relief valve is defective.
Traction pedal is sluggish.	Traction control linkage is stuck or binding. Piston pump manual control assembly is damaged. Piston pump or wheel motor(s) are worn or damaged. Charge pressure is low.



Machine travels too far before stopping when the traction pedal is released.	<p>Traction linkage is binding or out of adjustment.</p> <p>Piston pump manual servo control assembly is damaged.</p> <p>Traction pedal does not return to neutral.</p>
Traction power is lost or unit will not operate in either direction.	<p>Brakes are engaged or sticking.</p> <p>Traction control linkage is damaged or disconnected.</p> <p>Hydraulic reservoir oil level is low.</p> <p>Piston pump by-pass valve is open or damaged.</p> <p>Charge pressure is low.</p> <p>Traction circuit pressure is low.</p> <p>Rear wheel motor couplers are damaged.</p>
Steering inoperative or sluggish	<p>Engine speed is too low.</p> <p>Steering cylinder is binding.</p> <p>Reservoir oil level is low.</p> <p>Check valve in steering control valve is sticking, worn or damaged.</p> <p>Steering relief valve is stuck open.</p> <p>Steering control valve is worn or damaged.</p> <p>Steering cylinder leaks internally.</p> <p>Priority valve in gear pump is sticking, worn or damaged.</p> <p>Gear pump is worn or damaged.</p>
Turning steering wheel turns machine in the wrong direction.	<p>Hoses to the steering cylinder are reversed.</p> <p>Steering cylinder has internal leak.</p>
Spray pump hydraulic motor does not rotate.	<p>PWM Valve solenoid valve is sticking or damaged.</p> <p>PWM Valve solenoid or circuit wiring has electrical problem (see Chapter 5 – Electrical System).</p> <p>Priority valve in gear pump is sticking or damaged.</p> <p>Spray pump hydraulic motor is worn or damaged.</p>

# Testing

The most effective method for isolating problems in the hydraulic system is by using hydraulic test equipment such as pressure gauges and flow meters in the hydraulic circuits during various operational checks (See the Special Tools section in this Chapter).

## Before Performing Hydraulic Tests

**IMPORTANT:** All obvious areas such as hydraulic oil supply, oil filter, binding linkages, loose fasteners, or improper adjustments must be checked before assuming that a hydraulic component is the source of a hydraulic problem.



## WARNING

Before performing any work on the hydraulic system, system pressure must be relieved and all rotating machine parts must come to a stop. Turn ignition switch OFF and remove key from switch. When engine has stopped rotating, operate all hydraulic controls to relieve hydraulic system pressure.

## Precautions for Hydraulic Testing



## CAUTION

Failure to use gauges with recommended pressure (PSI) rating as listed in test procedures could result in damage to the gauge and possible personal injury from leaking hot oil.



## WARNING

Keep body and hands away from pin hole leaks or nozzles that eject hydraulic fluid under high pressure. Do not use hands to search for leaks; use paper or cardboard. Hydraulic fluid escaping under pressure can have sufficient force to penetrate the skin and cause serious injury. If fluid is injected into the skin, it must be surgically removed within a few hours by a doctor familiar with this type of injury. Gangrene may result from such an injury.



## CAUTION

All testing should be performed by two (2) people. One person should be in the seat to operate the machine, and the other person should read and record test results.

1. Clean machine thoroughly before disconnecting or disassembling any hydraulic components. Always keep in mind the need for cleanliness when working on hydraulic equipment. Contamination will cause excessive wear of hydraulic components.
2. Put metal caps or plugs on any hydraulic lines left open or exposed during testing or removal of components.
3. The engine must be in good operating condition. Use a phototac to check engine speed when performing a hydraulic test. Engine speed will affect the accuracy of the tester readings.
4. The inlet and the outlet hoses for tester with pressure and flow capabilities must be properly connected. If hoses are reversed, damage to the hydraulic tester or components can occur.
5. When using hydraulic tester with pressure and flow capabilities, completely open tester load valve before starting engine to minimize the possibility of damage to components.
6. Install tester fittings finger tight and far enough to make sure that they are not cross-threaded before tightening them with a wrench.
7. Position tester hoses to prevent rotating machine parts from contacting and damaging the hoses or tester.
8. Check oil level in the hydraulic reservoir. After connecting test equipment, make sure reservoir is full.
9. Check control linkages for improper adjustment, binding, or broken parts.
10. After installing test gauges, run engine at low speed and check for any hydraulic oil leaks.
11. All hydraulic tests should be made with the hydraulic oil at normal operating temperature.
12. Before returning machine to use, make sure that hydraulic reservoir has correct fluid level. Also, check for hydraulic leaks after test equipment has been removed from hydraulic system.

## Traction Circuit Charge Pressure Test

1. Make sure hydraulic oil is at normal operating temperature by operating the machine for approximately 10 minutes. Make sure the hydraulic tank is full.
2. Park machine on a level surface, stop engine, engage parking brake, and remove key from the ignition switch. After turning engine off, operate all hydraulic controls to relieve hydraulic system pressure.



### CAUTION

Prevent personal injury and/or damage to equipment. Read all WARNINGS, CAUTIONS, and Precautions for Hydraulic Testing at the beginning of this section.



Figure 13

1. Auxiliary test port plug

3. Remove plug from auxiliary test port on left side of piston (traction) pump (Fig. 13). Connect a 1000 PSI gauge into auxiliary test port.
4. After installing pressure gauge, start engine and run at idle speed. Check for hydraulic leakage and correct before proceeding with test.
5. Operate the engine at high idle engine speed (**3175 ± 25 RPM**) with no load on the hydraulic system.

#### **GAUGE READING TO BE 250 to 300 PSI.**

6. Stop engine and record test results.
7. If there is no pressure, or pressure is low, check for restriction in pump suction line. Also, inspect charge relief valve located in charge pump adapter on piston pump. If necessary, check for internal damage or worn parts in charge pump.
8. Also, with the pressure gauge still connected to the auxiliary test port on piston pump, take a gauge reading while operating the machine in forward and reverse. Start the engine and put throttle at high idle engine speed (**3175 ± 25 RPM**). Apply the brakes and push the traction pedal forward, then reverse.

#### **GAUGE READING TO BE 250 to 300 PSI.**

9. If charge pressure is good under no load, but drops below specification when under traction load, the piston (traction) pump and/or traction wheel motor(s) should be suspected of wear and inefficiency. When the piston pump and/or traction motor(s) are worn or damaged, the charge pump is not able to keep up with internal leakage in traction circuit components.
10. Disconnect pressure gauge from piston pump and reinstall plug to auxiliary test port.

## Traction Circuit Relief Pressure Test

1. Make sure hydraulic oil is at normal operating temperature by operating the machine for approximately 10 minutes. Make sure the hydraulic tank is full.
2. Park machine on a level surface, stop engine, engage parking brake, and remove key from the ignition switch. After turning engine off, operate all hydraulic controls to relieve hydraulic system pressure.



### CAUTION

Prevent personal injury and/or damage to equipment. Read all WARNINGS, CAUTIONS, and Precautions for Hydraulic Testing at the beginning of this section.

3. Clean and disconnect hydraulic pressure hose from piston pump fitting on right side of pump for function to be checked (Fig. 14):

Forward pressure hose is upper hose  
Reverse pressure hose is lower hose

4. Install T-connector with 10,000 PSI test gauge between the piston pump fitting and the disconnected hose.
5. After installing pressure gauge, start engine and run at idle speed. Check for hydraulic leakage and correct before proceeding with test.
6. Operate the engine at high idle speed ( $3175 \pm 25$  RPM).



### CAUTION

Move machine to an open area, away from people and obstructions.

7. Drive machine to an open area and engage the parking brake.
8. Sit on seat, apply brakes fully, and slowly depress the traction pedal in the appropriate direction (forward or reverse). While pushing traction pedal, look at pressure reading on gauge:

#### GAUGE READING TO BE:

Forward: **maximum of 4000 PSI**  
Reverse: **maximum of 4000 PSI**

9. Release traction pedal and stop engine. Record test results.

10. If traction pressure is too low, inspect traction pump relief valves (Fig. 15). Clean or replace valves as necessary. These cartridge type valves are factory set, and are not adjustable. If relief valves are in good condition, traction pump or wheel motors should be suspected of wear and inefficiency.

11. Disconnect pressure gauge from machine and reconnect hydraulic hose.

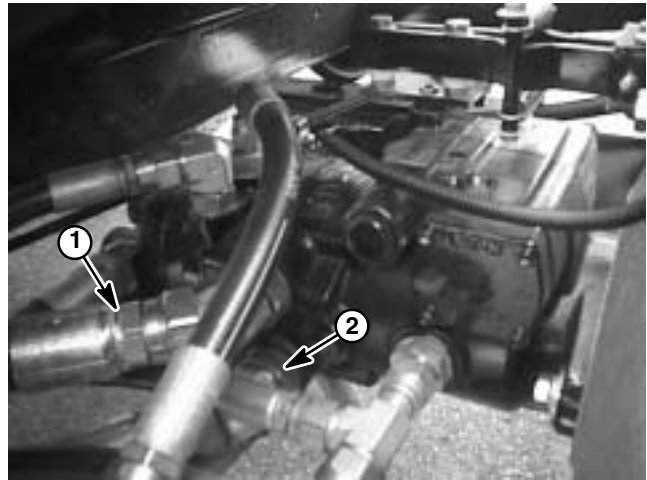

Figure 14

1. Forward pressure hose
2. Reverse pressure hose

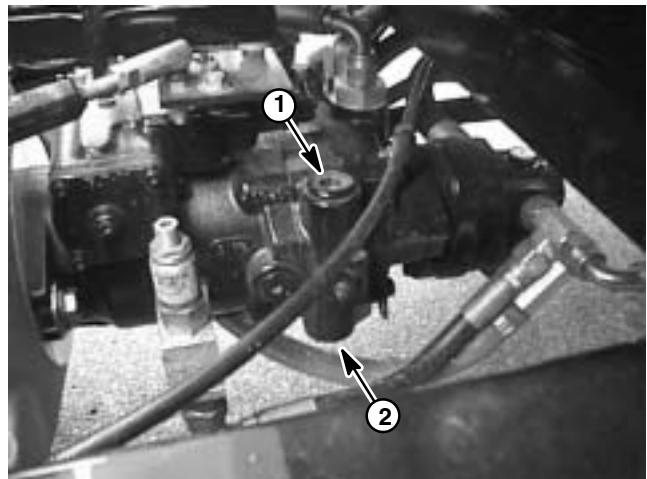

Figure 15

1. Forward relief valve
2. Reverse relief valve

## Gear Pump Flow Test

Output from the gear pump is divided by a priority flow divider to allow priority flow to the steering circuit and secondary flow to the spray pump drive circuit. To test gear pump flow, testing of both circuits is required. Total gear pump flow is the combined flow from the two circuits. If a problem is suspected in one of the two circuits, flow for that circuit should be measured to determine if the problem is pump related or is involved with other circuit components.

1. Make sure hydraulic oil is at normal operating temperature by operating the machine for approximately 10 minutes. Make sure the hydraulic tank is full.
2. Park machine on a level surface, stop engine, engage parking brake, and remove key from the ignition switch. After turning engine off, operate all hydraulic controls to relieve hydraulic system pressure.

	<b>CAUTION</b>
<b>Prevent personal injury and/or damage to equipment. Read all WARNINGS, CAUTIONS, and Precautions for Hydraulic Testing at the beginning of this section.</b>	

**IMPORTANT:** Make sure that the oil flow indicator arrow on the flow meter is showing that the oil will flow from the pump, through the tester, and into the hydraulic hose.

3. With the engine off, clean hose fitting and disconnect one of the circuit pressure hoses from the gear pump (Fig. 16). Install tester with pressure gauges and flow meter in series between the gear pump and the disconnected hose. **Make sure the tester flow control valve is open.**
4. After installing tester, start engine and run at idle speed. Check for hydraulic leakage and correct before proceeding with test.

**IMPORTANT:** The gear pump is a positive displacement type. If pump flow is completely restricted or stopped, damage to the gear pump, tester, or other components could occur.

5. Operate the engine at high idle speed (**3175 ± 25 RPM**). Verify engine speed with a phototac.

6. While watching tester pressure gauges, slowly close flow control valve on the tester until **800 PSI** is obtained on gauge. Verify engine speed continues to be correct (**3175 ± 25 RPM**). Record flow meter reading.

**GAUGE READING TO BE:** For steering circuit, flow should be approximately **3 GPM** at **800 PSI**. For spray motor circuit, flow should be approximately **9.5 GPM** at **800 PSI**.

7. Open tester flow control valve and stop engine.

**NOTE:** Relief pressure for steering and/or spray pump drive circuits can be determined with the tester positioned as described in this test.

8. Remove tester and reinstall disconnected hose. Complete steps 3 through 6 for other circuit hose.
9. If the **total** of the two flows is less than **12.5 GPM** or a pressure of **800 PSI** could not be obtained, check for restriction in pump suction line. If suction line is not restricted, remove gear pump and repair or replace as necessary.

If the **total** of the two flows is **12.5 GPM** but individual circuit flow is incorrect (e.g. steering circuit has 6 GPM and spray motor circuit has 6.5 GPM), suspect a problem with one of circuits or with the priority flow divider in the gear pump.



Figure 16

1. Steering circuit pressure hose
2. Spray motor circuit pressure hose

## Steering Circuit Relief Pressure Test

1. Make sure hydraulic oil is at normal operating temperature by operating the machine for approximately 10 minutes. Make sure the hydraulic tank is full.
2. Park machine on a level surface, stop engine, engage parking brake, and remove key from the ignition switch. After turning engine off, operate all hydraulic controls to relieve hydraulic system pressure.



### CAUTION

Prevent personal injury and/or damage to equipment. Read all WARNINGS, CAUTIONS, and Precautions for Hydraulic Testing at the beginning of this section.

3. Clean hose fitting and disconnect lower pressure hose from the left side of the gear pump (Fig. 17).
4. Install T-connector with 5,000 PSI pressure gauge in series with the pump and the disconnected hose.
5. After installing pressure gauge, start engine and run at idle speed. Check for hydraulic leakage and correct before proceeding with test.
6. Start engine and adjust engine speed to high idle ( $3175 \pm 25$  RPM).

**IMPORTANT: Hold steering wheel at full lock only long enough to get a system pressure reading. Holding the steering wheel against the stop for an extended period will damage the steering motor.**

7. Watch pressure gauge carefully while turning the steering wheel completely in one direction (full steering lock) and holding momentarily.
8. System pressure should be approximately **1000 PSI** as the relief valve lifts. Return steering wheel to the center position.
9. Slow engine speed and turn off machine. Record test results.
10. If relief pressure is incorrect, inspect for worn, stuck, or out of adjustment relief valve. Steering relief valve is located under the suction hose on the right side of the gear pump (Fig. 18). For adjustment procedure, see Adjust Relief Valve in the Adjustments section of this Chapter. After adjustment, retest relief valve pressure.
11. Disconnect T-connector and pressure gauge from gear pump and hose. Reconnect hose to the pump.



Figure 17

1. Steering circuit pressure hose
2. Spray motor circuit pressure hose

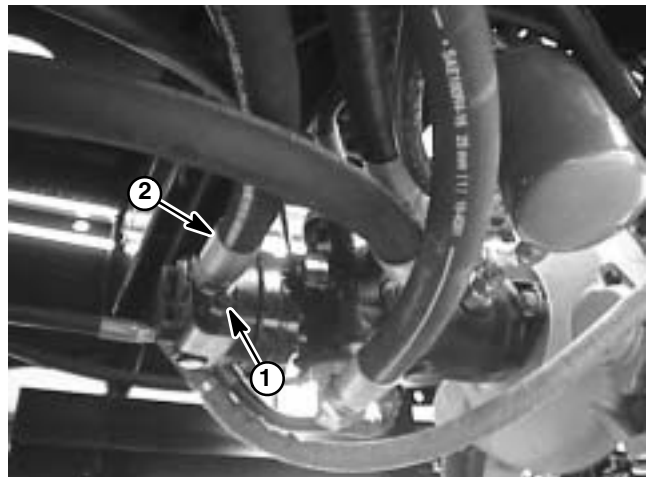

Figure 18

1. Steering relief valve
2. Gear pump suction hose

## Steering Control Valve and Steering Cylinder Test

1. Make sure hydraulic oil is at normal operating temperature by operating the machine for approximately 10 minutes.

2. Perform the Steering Circuit Relief Pressure and Gear Pump Flow tests to make sure that relief valve and gear pump are functioning correctly.

**NOTE:** This steering test procedure will be affected by incorrect tire pressure, binding of the hydraulic steering cylinder, excessive weight on the vehicle, and/or binding of the steering assembly (e.g. wheel spindles, tie rods). Make sure that these items are checked before proceeding with any hydraulic testing procedure.

3. Drive machine slowly in a figure eight on a flat level surface.

A. There should be no shaking or vibration in the steering wheel or front wheels.

B. Steering wheel movements should be followed **immediately** by a corresponding front wheel movement **without** the steering wheel continuing to turn.

4. Stop machine with the engine running. Turn steering wheel with small quick movements in both directions. Let go of the steering wheel after each movement.

A. The steering must immediately return to the neutral position.

B. The steering wheel or front wheels should **not** continue to turn.

5. If either of these performance tests indicate a steering problem, determine if the steering cylinder is faulty using the following procedure.

A. Park machine on a level surface with the spray system turned off.

B. With the engine running, turn the steering wheel to the right (clockwise) until the steering cylinder rod is fully contracted.

C. Turn engine off and engage the parking brake.

D. Read Precautions for Hydraulic Testing.

E. Clean and remove hydraulic hose from the fitting on the barrel end of the steering cylinder. Plug the end of the disconnected hose.



### WARNING

Keep body and hands away from disconnected hoses and fittings that might eject hydraulic fluid under high pressure. Use paper or cardboard, not hands, to search for leaks. Hydraulic fluid escaping under pressure can have sufficient force to penetrate the skin and cause serious injury. If fluid is injected into the skin, it must be surgically removed within a few hours by a doctor familiar with this type of injury. Gangrene may result from such an injury.

**IMPORTANT:** Do not turn steering wheel to the left (counterclockwise) as system damage may occur.

F. With the engine off, continue turning the steering wheel to the right (clockwise) with the steering cylinder fully contracted. Observe the open fitting on the steering cylinder as the wheel is turned. If oil comes out of the fitting while turning the steering wheel to the right, the steering cylinder has internal leakage and must be repaired or replaced.

G. Remove plug from the disconnected hydraulic hose. Reconnect hose to the steering cylinder.

6. If steering problem exists and the steering cylinder, steering circuit relief valve pressure and gear pump flow tested acceptably, steering control valve requires service (see Steering Control Valve and Steering Control Valve Service).

## Spray Pump Drive Circuit Relief Pressure Test

1. Make sure hydraulic oil is at normal operating temperature by operating the machine for approximately 10 minutes. Make sure the hydraulic tank is full.
2. Park machine on a level surface, stop engine, engage parking brake, and remove key from the ignition switch. After turning engine off, operate all hydraulic controls to relieve hydraulic system pressure.



### CAUTION

Prevent personal injury and/or damage to equipment. Read all WARNINGS, CAUTIONS, and Precautions for Hydraulic Testing at the beginning of this section.

**IMPORTANT:** Make sure that oil flow indicator arrow on the flow meter is showing that oil will flow from the pump, through the tester, and into the hydraulic hose.

3. Clean hydraulic fittings and install tester with pressure gauges and flow meter in series between the gear pump tee fitting and the spray motor circuit pressure hose (Fig. 19). **Make sure the tester flow control valve is completely open.**
  4. After installing tester, start engine and run at idle speed. Check for hydraulic leakage and correct before proceeding with test.
  5. Adjust engine speed to high idle (**3175 ± 25 RPM**).
- IMPORTANT:** The gear pump is a positive displacement type. If gear pump flow is completely restricted or stopped, damage to the gear pump, tester, or other components could occur.
6. Watch pressure gauge carefully while slowly closing the flow control valve on the tester.
  7. System pressure should be approximately **1500 PSI** as the relief valve lifts.

8. Open control valve on tester, slow engine speed and shut off engine. Record test results.

A. If relief pressure specification **is not** met, adjust spray circuit relief valve (Fig. 19) (see Adjust Relief Valve in the Adjustments section of this Chapter). After adjustment, retest relief valve pressure.

B. If relief pressure specification **is** met, disconnect tester from tee fitting and spray circuit pressure hose. Reconnect pressure hose to tee fitting.

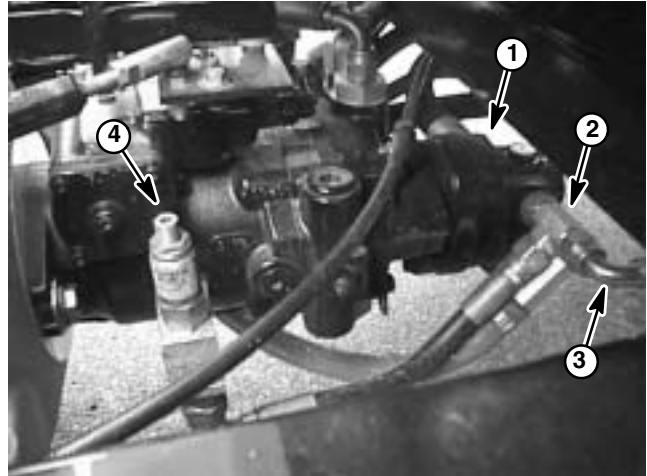

Figure 19

- |                          |                               |
|--------------------------|-------------------------------|
| 1. Gear pump             | 3. Spray circuit hose         |
| 2. Gear pump tee fitting | 4. Spray circuit relief valve |



## Wheel Motor Efficiency: Case Drain Test

**NOTE:** Over a period of time, a wheel motor can wear internally. A worn motor may by-pass oil to its case drain causing the motor to be less efficient. Eventually, enough oil loss will cause the wheel motor to stall under heavy load conditions. Continued operation with a worn, inefficient motor can generate excessive heat, cause damage to seals and other components in the hydraulic system and affect overall machine performance.

1. Make sure hydraulic oil is at normal operating temperature by operating the machine for approximately 10 minutes. Make sure the hydraulic tank is full.

2. Park machine on a level surface, stop engine, engage parking brake, and remove key from the ignition switch. After turning engine off, operate all hydraulic controls to relieve hydraulic system pressure.

**CAUTION**

**Prevent personal injury and/or damage to equipment. Read all WARNINGS, CAUTIONS, and Precautions for Hydraulic Testing at the beginning of this section.**

3. Make sure that traction pedal is adjusted to the neutral position (see Adjust Traction Pedal for Neutral in the Adjustments section of this Chapter).

4. Attach a heavy chain to the rear of the machine frame and an immovable object to prevent the machine from moving during testing.

5. Chock rear wheel being tested to prevent rotation of the wheel. Make sure parking brake is engaged.

6. Disconnect hydraulic tee fitting and pressure hose from rear wheel motor that **is not** being tested (Fig. 20). Cap disconnected fitting and hose. Plug ports in wheel motor to prevent contamination.

7. Disconnect hose from the upper hydraulic fitting on the right side of the piston (traction) pump (Fig. 21).

8. Install tester with pressure gauges and flow meter in series with the piston pump and the disconnected hose. **Make sure the tester flow control valve is fully open.**

9. Start engine and move throttle to high idle (**3175 ± 25 RPM**).

10. Sit on seat, apply brakes fully, and slowly depress the traction pedal in **forward** direction until **1000 PSI** is displayed on the tester pressure gauge.

11. Wheel motor internal leakage will be shown on flow meter in GPM. Flow should be **less than 2 GPM** for the tested wheel motor.

12. If specifications are not met, the tested wheel motor needs to be repaired or replaced as necessary.

13. If other wheel motor requires testing, complete steps 5 to 14 for the remaining motor.

14. Disconnect tester from pump hydraulic fitting and hose. Reconnect hose to pump connection. Reconnect hydraulic lines to rear wheel motor.

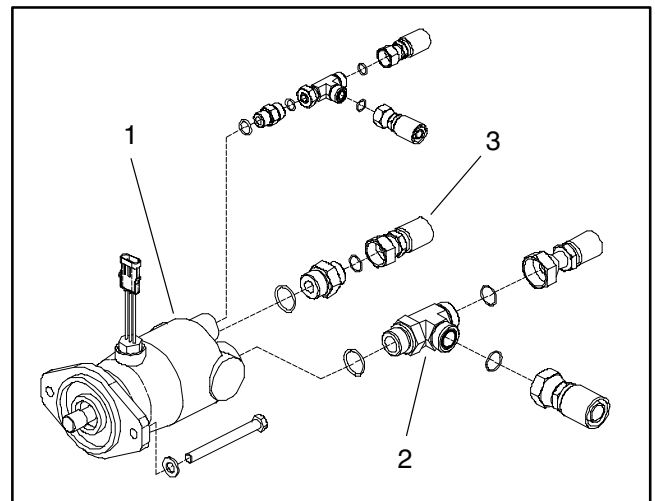

Figure 20

1. Wheel motor (RH shown)      3. Pressure hose  
2. Hydraulic tee fitting

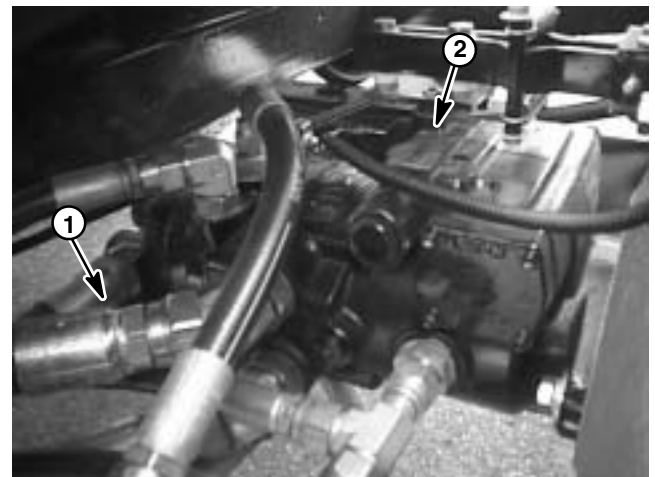

Figure 21

1. Upper hydraulic hose      2. Piston (traction) pump

## Pulse Width Modulated (PWM) Valve Flow Test

1. Make sure hydraulic oil is at normal operating temperature by operating the machine for approximately 10 minutes. Make sure the hydraulic tank is full.
2. Park machine on a level surface, stop engine, engage parking brake, and remove key from the ignition switch. After turning engine off, operate all hydraulic controls to relieve hydraulic system pressure.
3. Perform the Gear Pump Flow Test. Make sure that spray motor circuit hydraulic flow has been tested and recorded.



### CAUTION

Prevent personal injury and/or damage to equipment. Read all WARNINGS, CAUTIONS, and Precautions for Hydraulic Testing at the beginning of this section.

4. Disconnect hydraulic hose from the CF port fitting in the PWM Valve (Fig. 22).

**IMPORTANT:** Make sure that the oil flow indicator arrow on the flow meter is showing that the oil will flow from the PWM Valve CF port, through the tester, and into the hydraulic hose.

5. Install tester with pressure gauges and flow meter in series with the CF port fitting and the disconnected hydraulic hose. **Make sure the tester flow control valve is fully open.**
6. Make sure that spray tank has sufficient fluid for agitation. Make sure that spray pump is turned off.
7. If the machine has a Pro Control System installed, disconnect the Pro Control console computer.
8. Start engine and move throttle to high idle speed (**3175 ± 25 RPM**). The flow meter should indicate little, if any, hydraulic flow (less than 1 GPM) from the PWM Valve CF port.
  - A. If higher flow exists, stop engine, disconnect the PWM Valve solenoid connection from the machine harness and retest. If higher flow still exists, the PWM Valve should be replaced. If flow decreases to less than 1 GPM after solenoid is disconnected, inspect spray system electrical components and wiring before continuing PWM Valve flow test.
9. Turn all spray booms off. Turn spray pump and tank agitation on.

10. Using the application rate switch, increase the spray rate slightly while monitoring the flow tester. Check for hydraulic leakage and correct before proceeding with test.

11. With the engine still running at high idle (**3175 ± 25 RPM**), increase the spray rate with the application rate switch while monitoring the flow tester. As the spray rate is increased, hydraulic flow should increase as well. At maximum spray rate, hydraulic flow on the tester should approach spray motor circuit hydraulic flow previously tested and recorded. If hydraulic flow does not increase correctly, either the the circuit wiring to the PWM Valve solenoid or the PWM Valve is faulty.

12. Disconnect tester from PWM Valve CF port fitting and hydraulic hose. Reconnect hose to fitting.

13. If the machine has a Pro Control System installed, reconnect the Pro Control console computer.

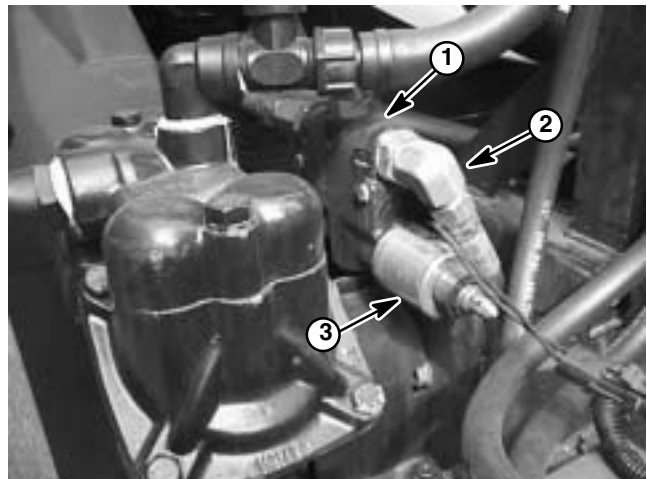

Figure 22

1. PWM Valve
2. CF port fitting
3. PWM Valve solenoid

# Adjustments

## Adjust Traction Pedal for Neutral

The piston (traction) pump control lever should return to the neutral position when the traction pedal is released. If the machine creeps when in neutral, check the following items:

1. The centering arms should be parallel to each other and also parallel to the centerline of the machine.
2. The centering arms should touch both front and rear bearings on control plate.
3. The centering arms should be tensioned by two springs.
4. The bearings attached to control plate should rotate freely.

Reposition the control plate on the piston pump control lever if needed.

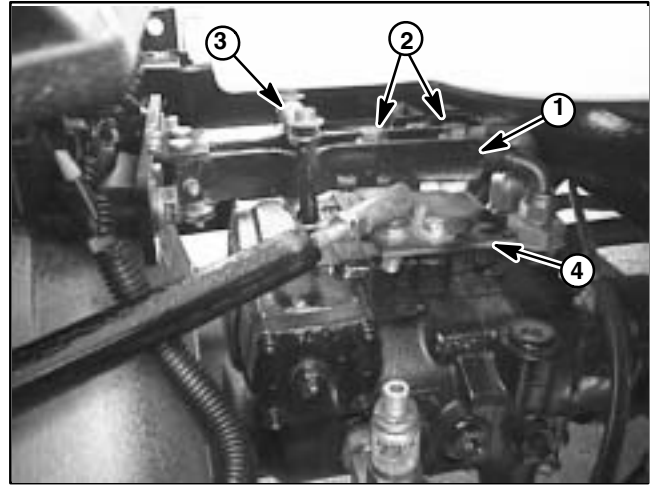

Figure 23

- |                  |                  |
|------------------|------------------|
| 1. Centering arm | 3. Spring        |
| 2. Bearing       | 4. Control plate |

## Adjust Relief Valve

The spray pump drive circuit relief valve is located on the left side of the piston (traction) pump (Fig. 24). The steering circuit relief valve is located under the suction hose on the right side of the gear pump (Fig. 25). Relief pressure should be tested before and after adjusting the relief valve (see Steering Circuit Relief Pressure Test and Spray Pump Drive Circuit Relief Pressure Test in the Testing section of this chapter). Adjustment of the relief valve can be performed as follows:

**NOTE:** Do not remove the relief valve for adjustment.

**NOTE:** To gain access to the adjustment socket and jam nut on the steering circuit relief valve, remove plastic cap.

1. To **increase** relief pressure setting, loosen jam nut on relief valve and turn the adjustment socket on the relief valve in a clockwise direction. A 1/8 turn on the socket will make a measurable change in relief pressure. Tighten jam nut after adjustment.
2. To **decrease** pressure setting, loosen jam nut on relief valve and turn the adjustment socket on the relief valve in a counterclockwise direction. A 1/8 turn on the socket will make a measurable change in relief pressure. Tighten jam nut after adjustment.
3. Recheck spray pump drive circuit relief pressure and readjust as needed.

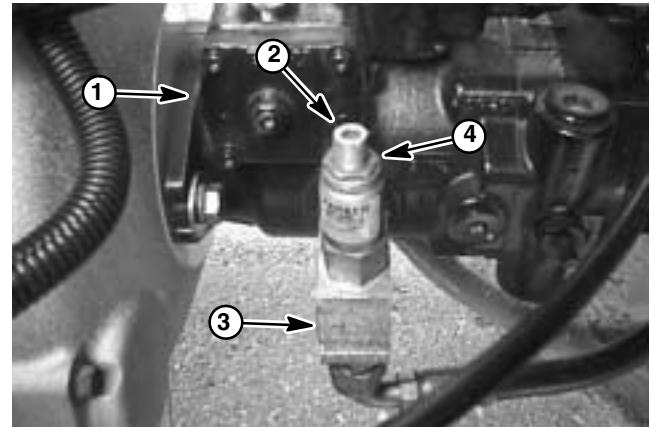

Figure 24

- |                               |                      |
|-------------------------------|----------------------|
| 1. Piston (traction) pump     | 3. Relief valve body |
| 2. Spray circuit relief valve | 4. Jam nut           |

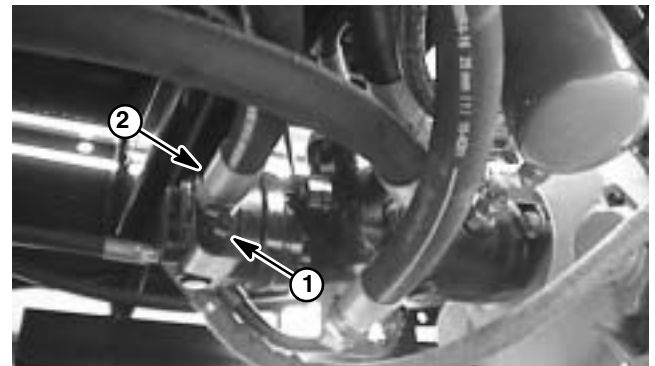

Figure 25

- |                          |              |
|--------------------------|--------------|
| 1. Steering relief valve | 2. Gear pump |
|--------------------------|--------------|

This page is intentionally blank.

# Service and Repairs

## General Precautions for Removing and Installing Hydraulic System Components

### Before Repair or Replacement of Components

1. Before removing any parts from the hydraulic system, park machine on a level surface, engage parking brake, and stop engine. Remove key from the ignition switch.
2. Clean machine before disconnecting, removing, or disassembling any hydraulic components. Make sure hydraulic components, hoses connections, and fittings are cleaned thoroughly. Always keep in mind the need for cleanliness when working on hydraulic components.

**CAUTION**

**Rotate steering wheel and depress traction pedal in both forward and reverse to relieve hydraulic system pressure and to avoid injury from pressurized hydraulic oil.**

3. After turning engine off, operate all hydraulic controls to relieve hydraulic system pressure.
4. Put caps or plugs on any hydraulic lines, hydraulic fittings, and components left open or exposed to prevent contamination.
5. Put labels on disconnected hydraulic lines and hoses for proper installation after repairs are completed.
6. Note the position of hydraulic fittings (especially elbow fittings) on hydraulic components before removal. Mark parts if necessary to make sure they will be aligned properly when reinstalling hydraulic hoses.

### Check Hydraulic Lines and Hoses

**WARNING**

**Keep body and hands away from pin hole leaks or nozzles that eject hydraulic fluid under high pressure. Use paper or cardboard, not hands, to search for leaks. Hydraulic fluid escaping under pressure can have sufficient force to penetrate the skin and cause serious injury. If fluid is injected into the skin, it must be surgically removed within a few hours by a doctor familiar with this type of injury. Gangrene may result from such an injury.**

### After Repair or Replacement of Components

1. Check oil level in the hydraulic reservoir and add correct oil if necessary. Drain and refill hydraulic reservoir and change oil filter if component failure was severe or system is contaminated (see Flush Hydraulic System).
2. Lubricate O-rings and seals with clean hydraulic oil before installing hydraulic components.
3. Make sure caps or plugs are removed from the hydraulic fittings and components before reconnecting.
4. Use proper tightening methods when installing hydraulic hoses and fittings (see Hydraulic Fitting Installation).
5. After repairs, check control linkages and cables for proper adjustment, binding, or broken parts.
6. After disconnecting or replacing any hydraulic component(s), operate machine functions slowly until air is out of system (see Charge Hydraulic System).
7. Check for hydraulic oil leaks. Shut off engine and correct leaks if necessary. Check oil level in hydraulic reservoir and add correct oil if necessary.

Check hydraulic lines and hoses daily for leaks, kinked lines, loose mounting supports, wear, loose fittings, weather deterioration and chemical deterioration. Make all necessary repairs before operating.

---

## Flush Hydraulic System

**IMPORTANT: Flush the hydraulic system any time there is a severe component failure or the system is contaminated. Contaminated oil appears milky, black, or contains metal particles.**

1. Make sure hydraulic oil warm by operating the machine for several minutes. Park machine on a level surface. Stop engine, apply parking brake, and remove key from ignition switch.

2. Clean area around hydraulic filter mounting area and remove filter (see Operator's Manual). Drain filter into a suitable container. Properly dispose removed filter.

3. Drain hydraulic reservoir into a suitable container (see Operator's Manual).

4. Drain hydraulic system. Drain all hoses and components while the system is warm.

5. Make sure filter mounting surface is clean. Apply clean hydraulic oil to gasket on new filter. Screw filter onto filter head until gasket contacts mounting surface, then tighten filter 3/4 turn further.

6. Reinstall all hoses and hydraulic components.

**NOTE:** Use only hydraulic fluids specified in Operator's Manual. Other fluids could cause system damage.

7. Fill hydraulic oil reservoir (see Operator's Manual).

8. Disconnect and ground spark plug wires to prevent engine from starting.

9. Turn ignition key switch to start; engage starter for ten (10) seconds to prime hydraulic pump. Repeat this step again.

10. Reconnect spark plug wires.

11. Start engine and run at low idle speed ( $675 \pm 25$  RPM) for a minimum of two (2) minutes.

12. Increase engine speed to high idle ( $3175 \pm 25$  RPM) for minimum of one (1) minute under no load.

13. Turn steering wheel in both directions several times.

14. Shut off engine and check for hydraulic oil leaks. Check oil level in hydraulic reservoir and add correct oil if necessary.

15. Operate the machine for two (2) hours under normal operating conditions.

16. Check condition of hydraulic oil. If the fluid shows any signs of contamination repeat steps 1 through 12 again.

17. Resume normal operation and follow recommended maintenance intervals.

## Charge Hydraulic System

**NOTE:** When initially starting the hydraulic system with new or rebuilt components such as motors or pumps, it is important that the hydraulic system be charged properly. Air must be purged from the system and its components to reduce the chance of damage.

**IMPORTANT: Change hydraulic oil filter whenever hydraulic components are repaired or replaced.**

1. Position machine on a level surface, engage parking brake and remove key from the ignition switch.
2. Make sure all hydraulic connections, lines, and components are tight.
3. If component failure was severe or the system is contaminated, flush and refill hydraulic system and reservoir (see Flush Hydraulic System in this section).
4. Make sure hydraulic reservoir is full. Add correct hydraulic oil if necessary (see Operator's Manual).
5. Check control rod to the piston (traction) pump for proper adjustment, binding, or broken parts.
6. Disconnect and ground spark plug wires to prevent engine from starting.
7. Make sure traction pedal is in the neutral position. Turn ignition key switch; engage starter for ten (10) seconds to prime the piston (traction) and gear pumps. Repeat this step again.
8. Reconnect spark plug wires.



### WARNING

**Before jacking up the machine, review and follow Jacking Instructions in Chapter 1 – Safety.**

9. Raise rear wheels off the ground, and place support blocks under the frame. Chock front wheels to prevent movement of the machine.
10. Start engine and run it at low idle ( $675 \pm 25$  RPM). The charge pump should pick up oil and fill the hydraulic system. If there is no indication of fill in 30 seconds, stop the engine and determine the cause.

11. After the hydraulic system starts to show signs of fill, rotate steering wheel until the steering cylinder rod moves in and out several times. If the cylinder rod does not move after 15 seconds, or the gear pump emits abnormal sounds, shut the engine off immediately and determine cause or problem. Inspect for the following:

- A. Loose filter or suction lines.
- B. Blocked suction line.
- C. Faulty charge relief valve.
- D. Faulty gear pump.

12. If cylinder does move in 15 seconds, proceed to step 13.

13. Operate the traction pedal in the forward and reverse directions. The rear wheels should rotate in the proper direction.

- A. If the wheels rotate in the wrong direction, stop engine, remove lines from side of piston (traction) pump, and reverse the connections.
- B. If the wheels rotate in the proper direction, stop engine.

14. Adjust traction pedal to the neutral position (see Operator's Manual).

15. Check operation of the neutral switch (see Operator's Manual).

16. Remove blocks from frame and lower machine to the ground. Remove chocks from front wheels.

17. If the piston (traction) pump or a wheel motor was replaced or rebuilt, run the machine so wheels turn slowly for 10 minutes.

18. Operate machine by gradually increasing its work load to full over a 10 minute period.

19. Stop the machine. Check hydraulic reservoir and fill if necessary. Check hydraulic components for leaks and tighten any loose connections.

# Gear Pump

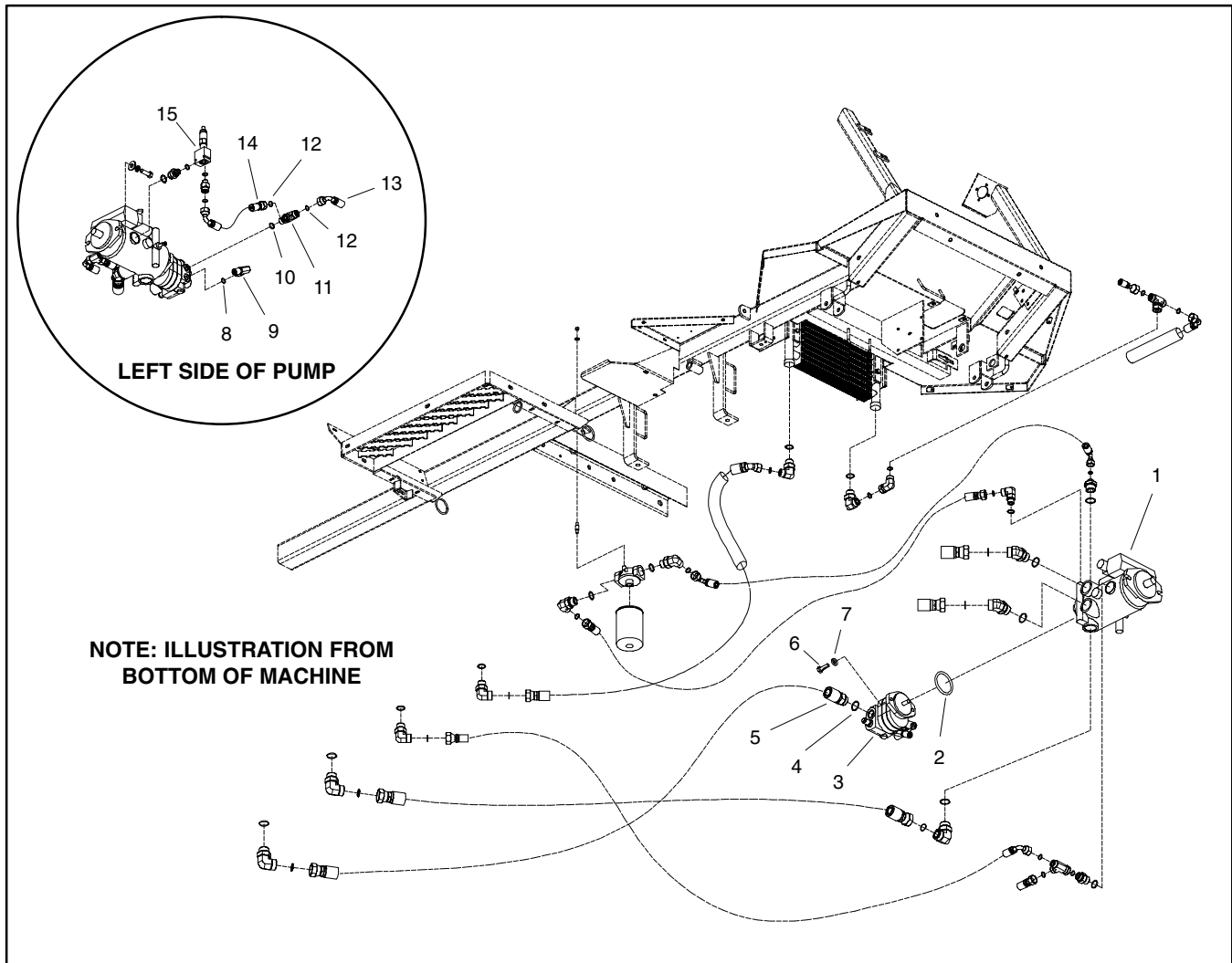

Figure 26

- |                                       |   |                                      |
|---------------------------------------|---|--------------------------------------|
| 1. Piston (traction) pump             | 6. Cap screw (2 used)                   | 11. Hydraulic tee fitting            |
| 2. O-ring                             | 7. Flat washer (2 used)                 | 12. O-ring                           |
| 3. Gear pump                          | 8. O-ring                               | 13. Hydraulic hose (to PWM valve)    |
| 4. O-ring                             | 9. Hydraulic hose (to steering control) | 14. Hydraulic hose (to relief valve) |
| 5. Hydraulic hose (gear pump suction) | 10. O-ring                              | 15. Relief valve assembly            |



### Removal (Fig. 26)

1. Park machine on a level surface, stop engine, engage parking brake, and remove key from the ignition switch.
2. To prevent contamination of hydraulic system during gear pump removal, thoroughly clean exterior of pump assembly.



3. Operate all hydraulic controls to relieve hydraulic system pressure.
4. Read the General Precautions for Removing and Installing Hydraulic System Components at the beginning of the Service and Repairs section of this chapter.

**NOTE:** To ease reassembly, tag hydraulic hoses to show their correct position on the gear pump.

5. Put drain pan below the gear pump. Remove hydraulic hoses and fittings connected to gear pump. Put plugs or caps on disconnected hydraulic hoses and open ports of pump to prevent contamination of the system.
6. Support the gear pump to prevent it from falling (Fig. 27). Remove two (2) cap screws and flat washers retaining gear pump to piston pump.
7. Carefully pull gear pump from piston pump and lower it out of the machine. Locate and retrieve o-ring from between pumps.

### Installation (Fig. 26)

1. Lubricate new o-ring and position it to gear pump. Carefully raise gear pump and position it to the piston pump.
2. Align spline teeth and slide gear pump input shaft into piston pump coupling. Support gear pump to prevent it from falling while installing two (2) cap screws and flat washers securing gear pump to piston pump.
3. Remove plugs or caps from disconnected hydraulic hoses and ports of the gear pump. Lubricate new o-rings and install fittings and hoses to correct location on gear pump.

4. Install new hydraulic oil filter and fill hydraulic reservoir with correct oil (see Operator's Manual).
5. Properly fill hydraulic system (see Charge Hydraulic System in the Service and Repairs section of this chapter).
6. Stop engine and check for hydraulic oil leaks. Check hydraulic reservoir oil level.



Figure 27

1. Gear pump
2. Piston pump

## Gear Pump Service

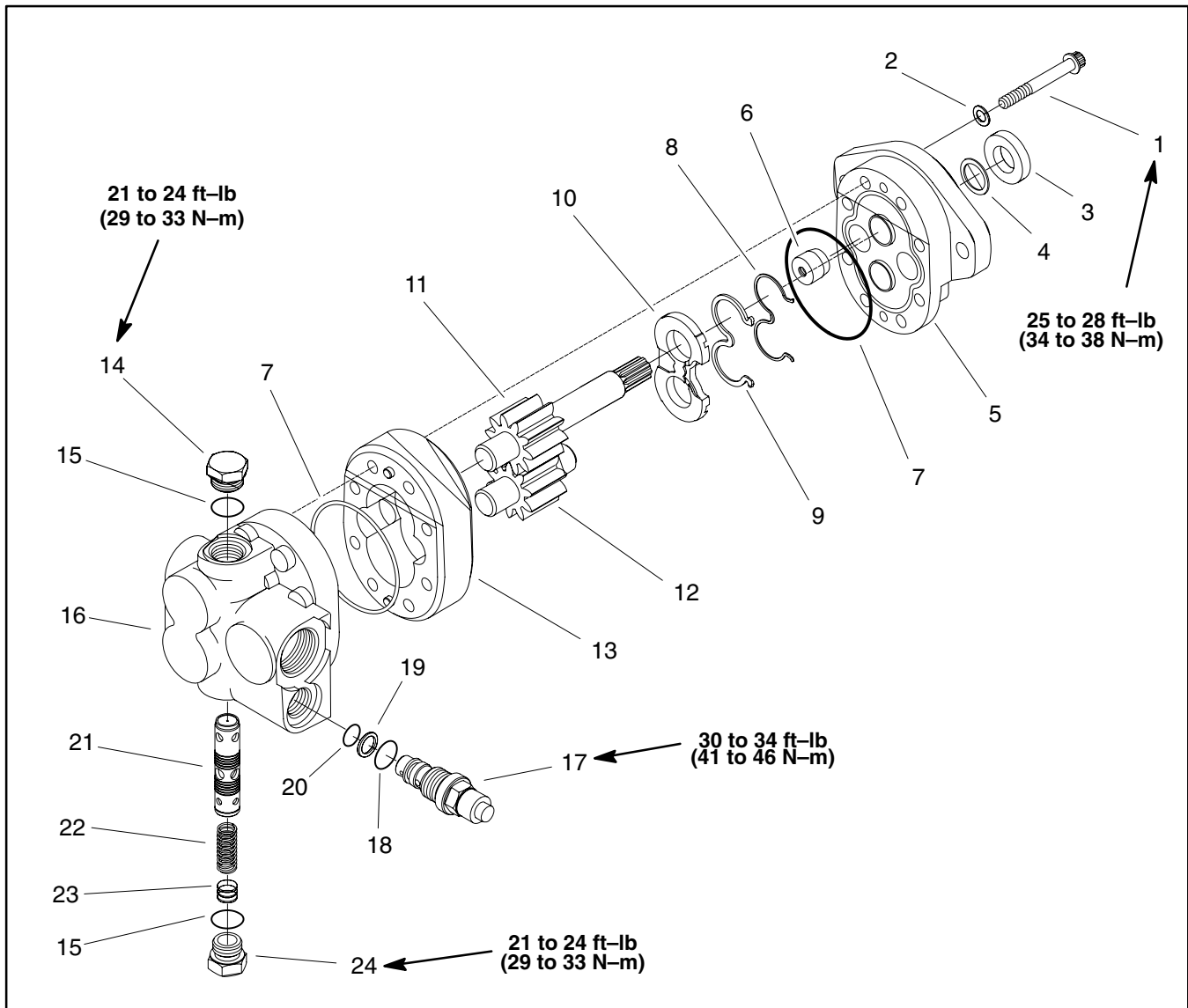

Figure 28

- |                       |                  |                        |
|-----------------------|------------------|------------------------|
| 1. Cap screw (8 used) | 9. Pressure seal | 17. Relief valve       |
| 2. Washer (4 used)    | 10. Wear plate   | 18. O-ring             |
| 3. Shaft seal         | 11. Drive gear   | 19. Backup washer      |
| 4. Washer             | 12. Idler gear   | 20. O-ring             |
| 5. Front plate        | 13. Body         | 21. Flow divider spool |
| 6. Plug               | 14. Plug         | 22. Spring             |
| 7. O-ring             | 15. O-ring       | 23. Disc               |
| 8. Backup gasket      | 16. Backplate    | 24. Plug               |

**NOTE:** For service of the gear pump, see the Eaton Model 26000 Single Gear Pumps Repair Information at the end of this chapter.

This page is intentionally blank.

## Piston (Traction) Pump

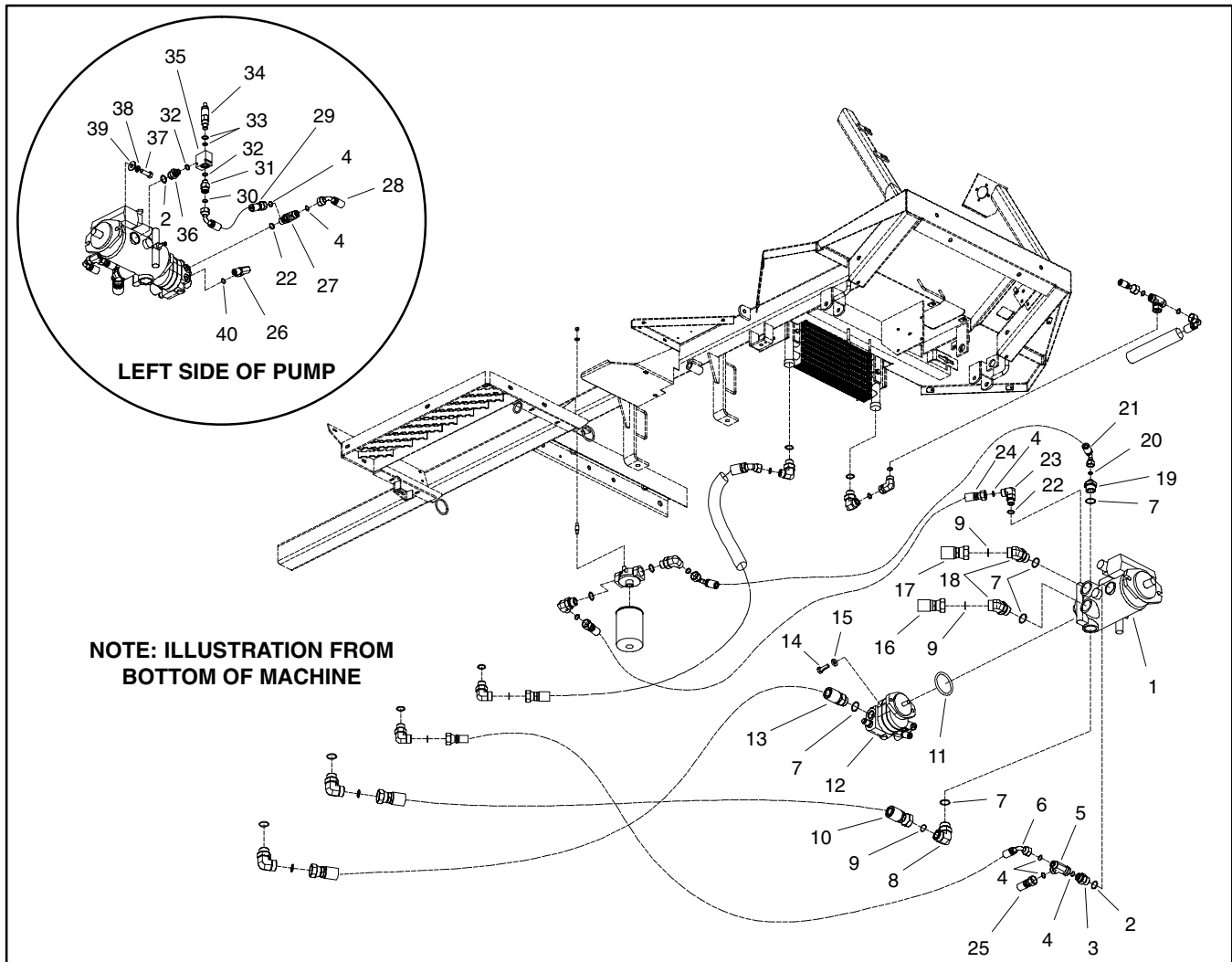

Figure 29

- |  |  |                                   |
|--|--|-----------------------------------|
| 1. Piston (traction) pump                | 15. Flat washer (2 used)                 | 28. Hydraulic hose (to PWM valve) |
| 2. O-ring                                | 16. Hydraulic hose (to LH wheel motor)   | 29. Hydraulic hose                |
| 3. Hydraulic adapter                     | 17. Hydraulic hose (to RH wheel motor)   | 30. O-ring                        |
| 4. O-ring                                | 18. 45° hydraulic fitting                | 31. Hydraulic fitting             |
| 5. Hydraulic tee fitting                 | 19. Straight fitting                     | 32. O-ring                        |
| 6. Hydraulic hose (to reservoir)         | 20. O-ring                               | 33. Seal kit                      |
| 7. O-ring                                | 21. Hydraulic hose (to oil filter)       | 34. Relief valve                  |
| 8. 90° hydraulic fitting                 | 22. O-ring                               | 35. Relief valve body             |
| 9. O-ring                                | 23. 90° hydraulic fitting                | 36. Hydraulic adapter             |
| 10. Hydraulic hose (piston pump suction) | 24. Hydraulic hose (from oil filter)     | 37. Cap screw (2 used)            |
| 11. O-ring                               | 25. Hydraulic hose (from wheel motors)   | 38. Lock washer (2 used)          |
| 12. Gear pump                            | 26. Hydraulic hose (to steering control) | 39. Flat washer (2 used)          |
| 13. Hydraulic hose (gear pump suction)   | 27. Hydraulic tee fitting                | 40. O-ring                        |

### Removal (Fig. 29)

1. Park machine on a level surface, stop engine, engage parking brake, and remove key from the ignition switch.
2. To prevent contamination of hydraulic system during pump removal, thoroughly clean exterior of pump assembly.



3. Operate all hydraulic controls to relieve hydraulic system pressure.
4. Remove traction rod from control plate on piston pump by removing lock nut (Fig. 31).
5. Disconnect two (2) wires from neutral switch on piston pump (Fig. 31).
6. Remove flange head screw and flange nut that secures R-clamp and right side brake cable to pump assembly (Fig. 31).
7. Read the General Precautions for Removing and Installing Hydraulic System Components at the beginning of the Service and Repairs section of this chapter.

**NOTE:** To ease reassembly, tag hydraulic hoses to show their correct position on the pump assembly.

8. Put a drain pan below the pump assembly. Remove hydraulic hoses and fittings connected to piston and gear pumps. Put plugs or caps on disconnected hydraulic hoses to prevent contamination of the system. Put plugs in open ports of pumps.
9. Support the pump assembly to prevent it from falling. Remove two (2) cap screws, lock washers and flat washers that retain pump assembly to engine bell housing (Fig. 30).
10. Carefully pull pump assembly from engine and lower it out of the machine.
11. If needed, separate gear pump from piston pump (see Gear Pump Removal in this section).

### Installation (Fig. 29)

1. If gear pump was removed from piston pump, install gear pump to piston pump (see Gear Pump Installation in this section).
2. Apply antisieze lubricant to piston pump shaft splines.
3. Carefully raise pump assembly and position it to the engine. Make sure that both bushings on control plate are between centering arms on rear of engine (Fig. 31).
4. Align spline teeth and slide piston pump input shaft into engine coupling spline. Support pump to prevent it from falling while installing two (2) cap screws, lock washers and flat washers to secure pump to engine bell housing.
5. Secure traction rod to control plate on piston pump by installing lock nut (Fig. 31).
6. Connect two (2) wires to neutral switch on piston pump (Fig. 31).

7. Remove plugs or caps from disconnected hydraulic hoses and ports of the pump assembly. Lubricate new o-rings and install fittings and hoses to correct location on gear and piston pumps.
8. Secure R-clamp and right side brake cable to pump assembly with flange head screw and flange nut.
9. Install new hydraulic oil filter and fill hydraulic reservoir with correct oil (see Operator's Manual).
10. Properly fill hydraulic system (see Charge Hydraulic System in the Service and Repairs section of this chapter).
11. Stop engine and check for hydraulic oil leaks. Check hydraulic reservoir oil level.

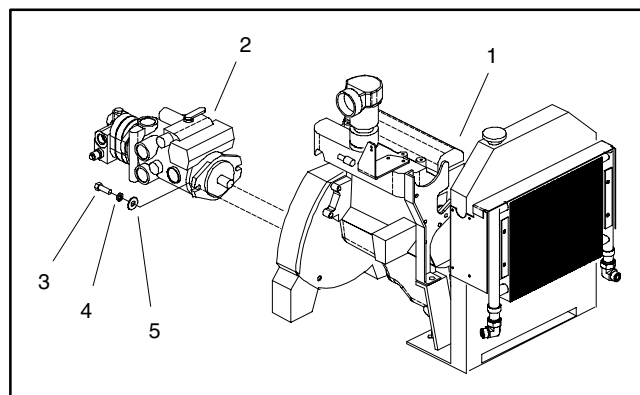

Figure 30

- |                       |                         |
|-----------------------|-------------------------|
| 1. Engine assembly    | 4. Lock washer (2 used) |
| 2. Pump assembly      | 5. Flat washer (2 used) |
| 3. Cap screw (2 used) |                         |

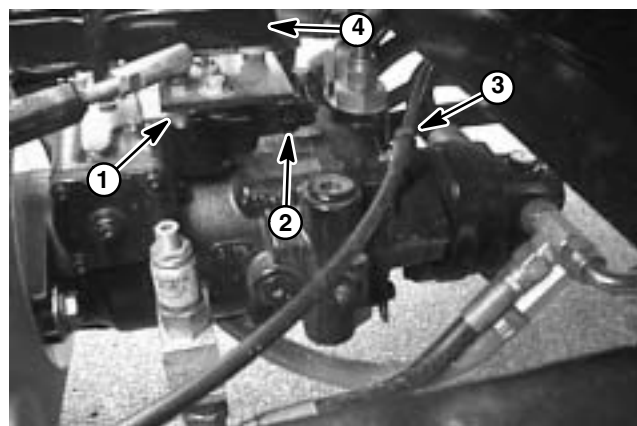

Figure 31

- |                          |                        |
|--------------------------|------------------------|
| 1. Traction rod lock nut | 3. R-clamp/brake cable |
| 2. Neutral switch        | 4. Centering arm       |

## Piston (Traction) Pump Service

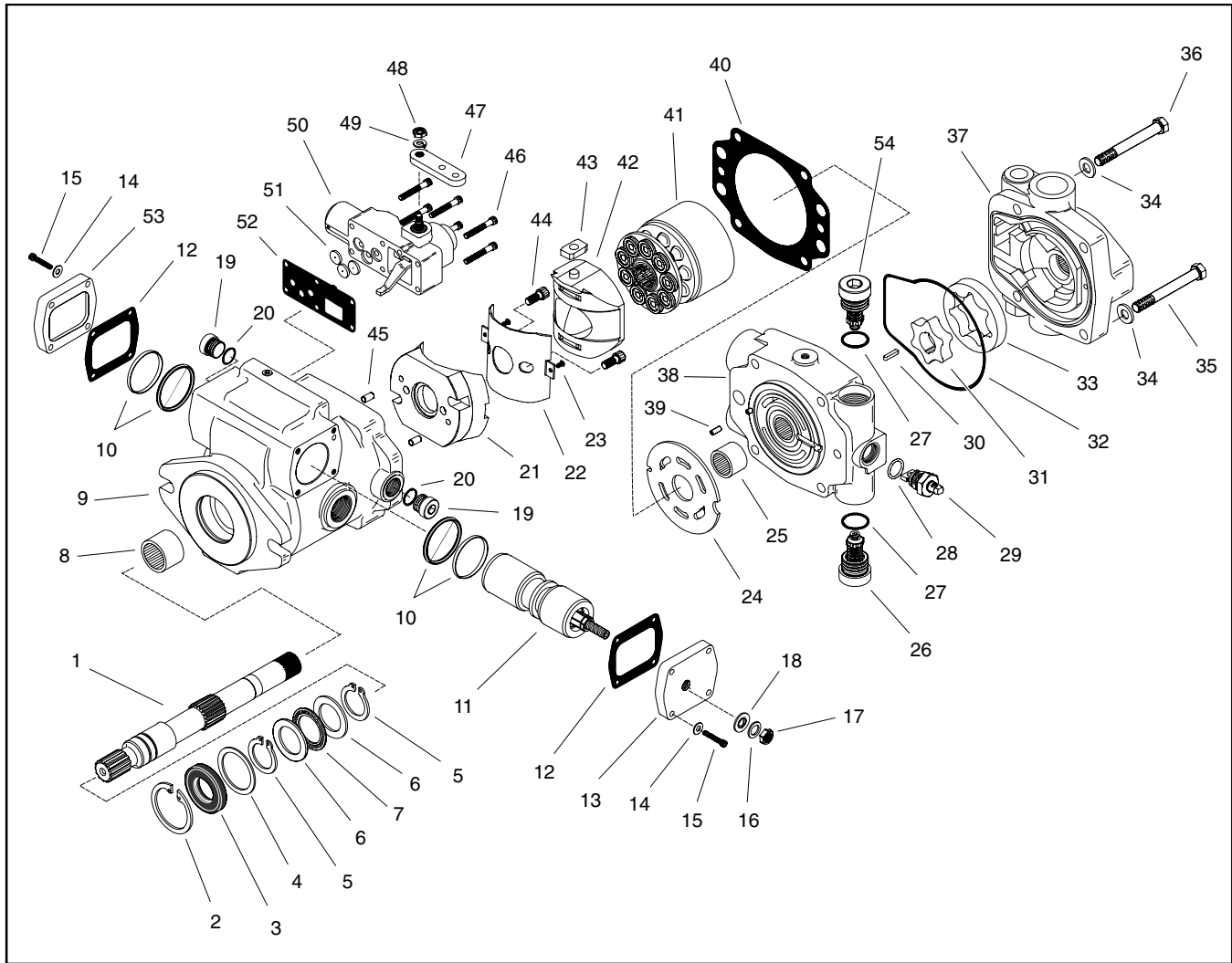

Figure 32

- |  |                                     |                                   |
|--|-------------------------------------|-----------------------------------|
| 1. Drive shaft                           | 19. Plug                            | 37. Charge pump adapter           |
| 2. Retaining ring                        | 20. O-ring                          | 38. Backplate                     |
| 3. Shaft seal                            | 21. Cradle                          | 39. Roll pin                      |
| 4. Washer                                | 22. Bushing                         | 40. Housing gasket                |
| 5. Retaining ring                        | 23. Screw                           | 41. Rotating kit                  |
| 6. Thrust bearing race                   | 24. Valve plate                     | 42. Camplate                      |
| 7. Thrust bearing                        | 25. Bearing                         | 43. Servo piston follower         |
| 8. Bearing                               | 26. Reverse relief valve            | 44. Cap screw (2 used)            |
| 9. Housing                               | 27. O-ring                          | 45. Bushing dowel (2 used)        |
| 10. Seal set                             | 28. O-ring                          | 46. Socket head screw (6 used)    |
| 11. Servo piston                         | 29. Bypass valve                    | 47. Control arm                   |
| 12. Gasket                               | 30. Key                             | 48. Hex nut                       |
| 13. Cover plate                          | 31. Geroter (inner)                 | 49. Lock washer                   |
| 14. Flat washer (4 used per cover)       | 32. O-ring                          | 50. Manual servo control assembly |
| 15. Socket head screw (4 used per cover) | 33. Geroter (outer)                 | 51. Control orifice (3 used)      |
| 16. Washer                               | 34. Flat washer (4 used)            | 52. Housing gasket                |
| 17. Jam nut                              | 35. Cap screw (3 1/2" long: 2 used) | 53. Cover plate                   |
| 18. Seal washer                          | 36. Cap screw (4" long: 2 used)     | 54. Forward relief valve          |

**NOTE:** For service of the piston (traction) pump, see the Eaton Model 72400 Servo Controlled Piston Pump Repair Information at the end of this chapter.

## Manual Servo Control Assembly

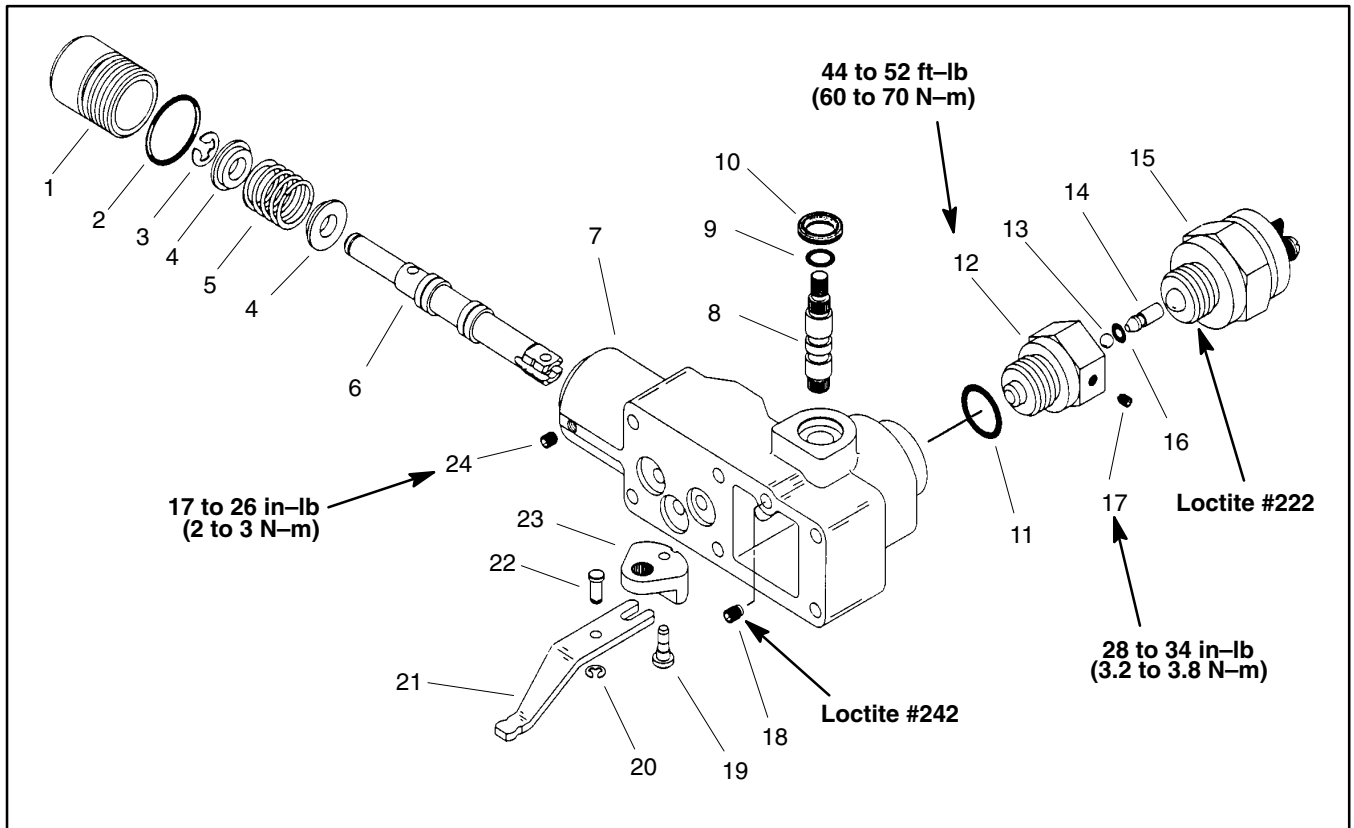

Figure 33

- 1. Plug
- 2. O-ring
- 3. Retaining ring
- 4. Spring retainer
- 5. Spring
- 6. Spool valve
- 7. Control housing
- 8. Input shaft

- 9. O-ring
- 10. Wiper seal
- 11. O-ring
- 12. Adaptor
- 13. Ball
- 14. Pin
- 15. Neutral switch
- 16. O-ring

- 17. Set screw
- 18. Set screw
- 19. Pin
- 20. Retaining ring
- 21. Feedback link
- 22. Dowel pin
- 23. Bell crank
- 24. Set screw

**NOTE:** For service of the manual servo control assembly (including neutral switch adjustment), see the Eaton Model 72400 Servo Controlled Piston Pump Repair Information at the end of this chapter.

# Wheel Motors

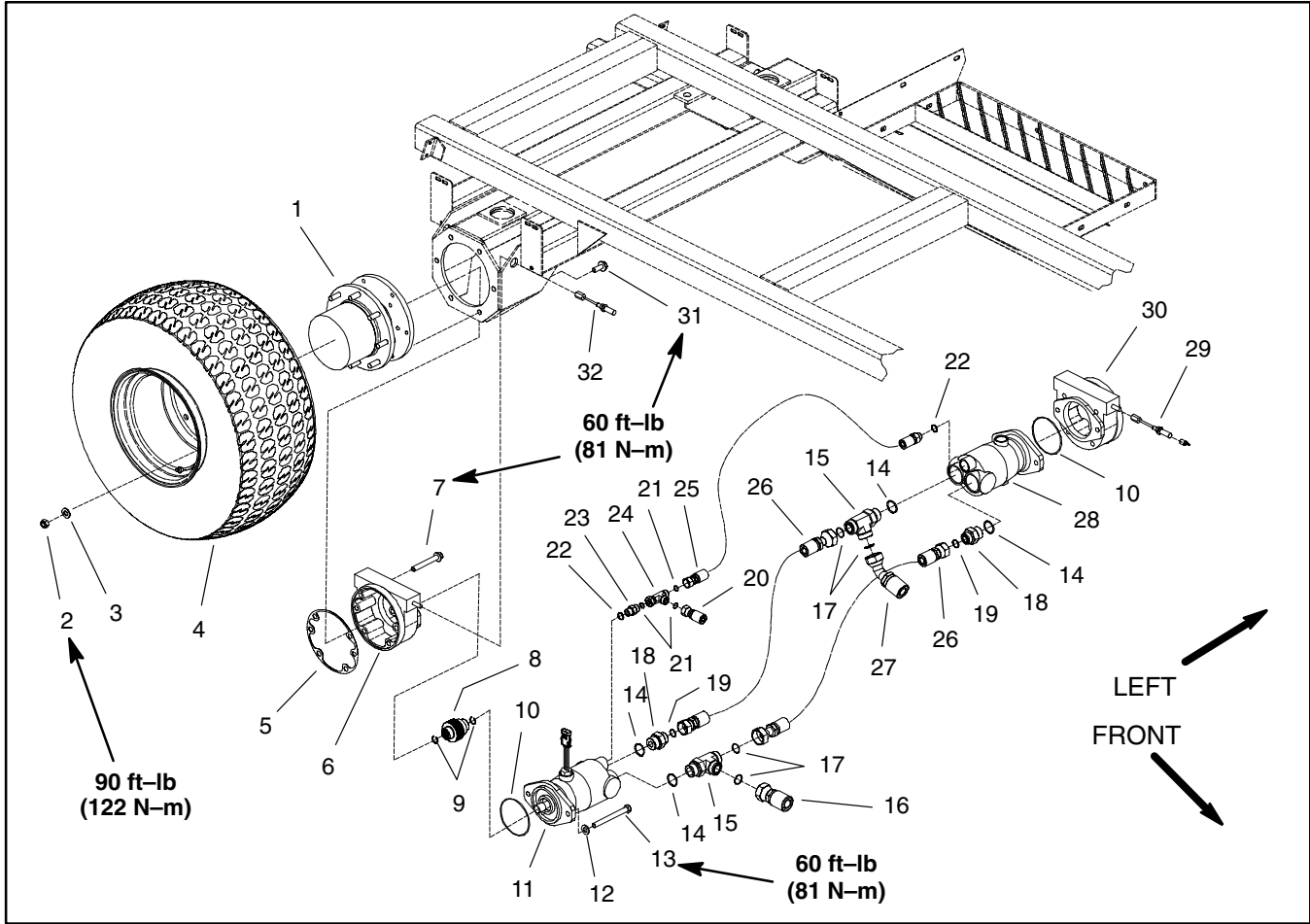

Figure 34

- |   |   |   |
|---|---|---|
| 1. Planetary assembly                   | 12. Flat washer (2 used per motor)      | 23. Hydraulic adapter                   |
| 2. Lock nut (8 used per wheel)          | 13. Cap screw (2 used per motor)        | 24. Hydraulic tee fitting               |
| 3. Flat washer (8 used per wheel)       | 14. O-ring                              | 25. Hydraulic hose                      |
| 4. Tire and wheel assembly              | 15. Hydraulic tee fitting               | 26. Hydraulic hose                      |
| 5. Gasket                               | 16. Hyd. hose (to top pump fitting)     | 27. Hyd. hose (to bottom pump fitting)  |
| 6. RH brake assembly                    | 17. O-ring                              | 28. LH wheel motor                      |
| 7. Flange head screw (4 used per brake) | 18. Hydraulic adapter                   | 29. LH brake cable                      |
| 8. Splined brake shaft                  | 19. O-ring                              | 30. LH brake assembly                   |
| 9. Retaining ring                       | 20. Hydraulic hose (to pump case drain) | 31. Flange head screw (6 used per side) |
| 10. O-ring                              | 21. O-ring                              | 32. RH brake cable                      |
| 11. RH wheel motor                      | 22. O-ring                              |   |



## Removal (Fig. 34)

1. Park machine on a level surface, stop engine, engage parking brake, and remove key from the ignition switch.



2. Operate all hydraulic controls to relieve hydraulic system pressure.

3. Read the General Precautions for Removing and Installing Hydraulic System Components at the beginning of the Service and Repairs section of this chapter.

4. To prevent contamination of hydraulic system during motor removal, thoroughly clean exterior of motor and fittings.

**NOTE:** To ease reassembly, tag the hydraulic hoses to show their correct position on the wheel motor.

5. Disconnect hydraulic hoses from fittings on wheel motor. Put caps or plugs on hydraulic lines, fittings, and ports to prevent contamination.

6. If right side wheel motor is being removed, unplug speed sensor connector from machine wiring harness.

**IMPORTANT:** Before loosening fasteners, support wheel motor to prevent motor from falling.

7. Support the pump assembly to prevent it from falling. Remove two (2) cap screws and flat washers that secure wheel motor to brake and planetary assemblies. Remove wheel motor from machine.

## Installation (Fig. 34)

1. If splined brake shaft was removed from brake assembly, make sure that the stepped end of the shaft is aligned toward the hydraulic wheel motor (Fig. 35). Also, make sure that splines engage rotating discs in brake assembly.

2. Position wheel motor to brake assembly.

3. Align splines on motor shaft and splined brake shaft. Slide motor to brake assembly.

4. Secure motor to brake and planetary assemblies with cap screws and flat washers. Torque cap screws 60 ft–lb (81 N–m).

5. Remove plugs from hydraulic lines, fittings, and ports. Lubricate new o–rings and attach hydraulic hoses to wheel motor.

6. If right side wheel motor was removed, plug speed sensor connector into machine wiring harness.

7. Check fluid level in hydraulic oil reservoir and adjust as required (see Operator's Manual).

8. Operate machine and inspect for leaks.

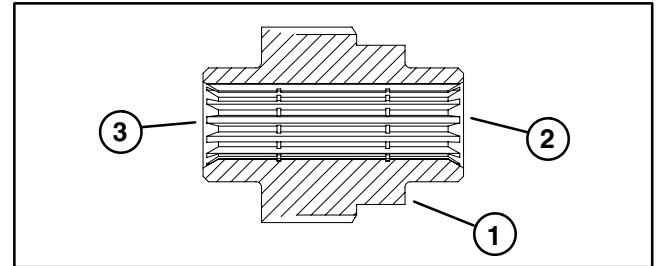

Figure 35

1. Splined brake shaft step      3. Planetary assembly end  
2. Hydraulic motor end

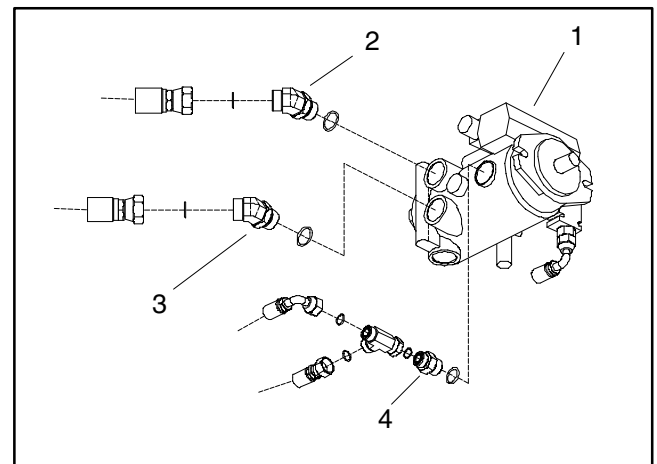

Figure 36

1. Piston (traction) pump      3. Bottom pump fitting  
2. Top pump fitting      4. Case drain fitting

## Wheel Motor Service

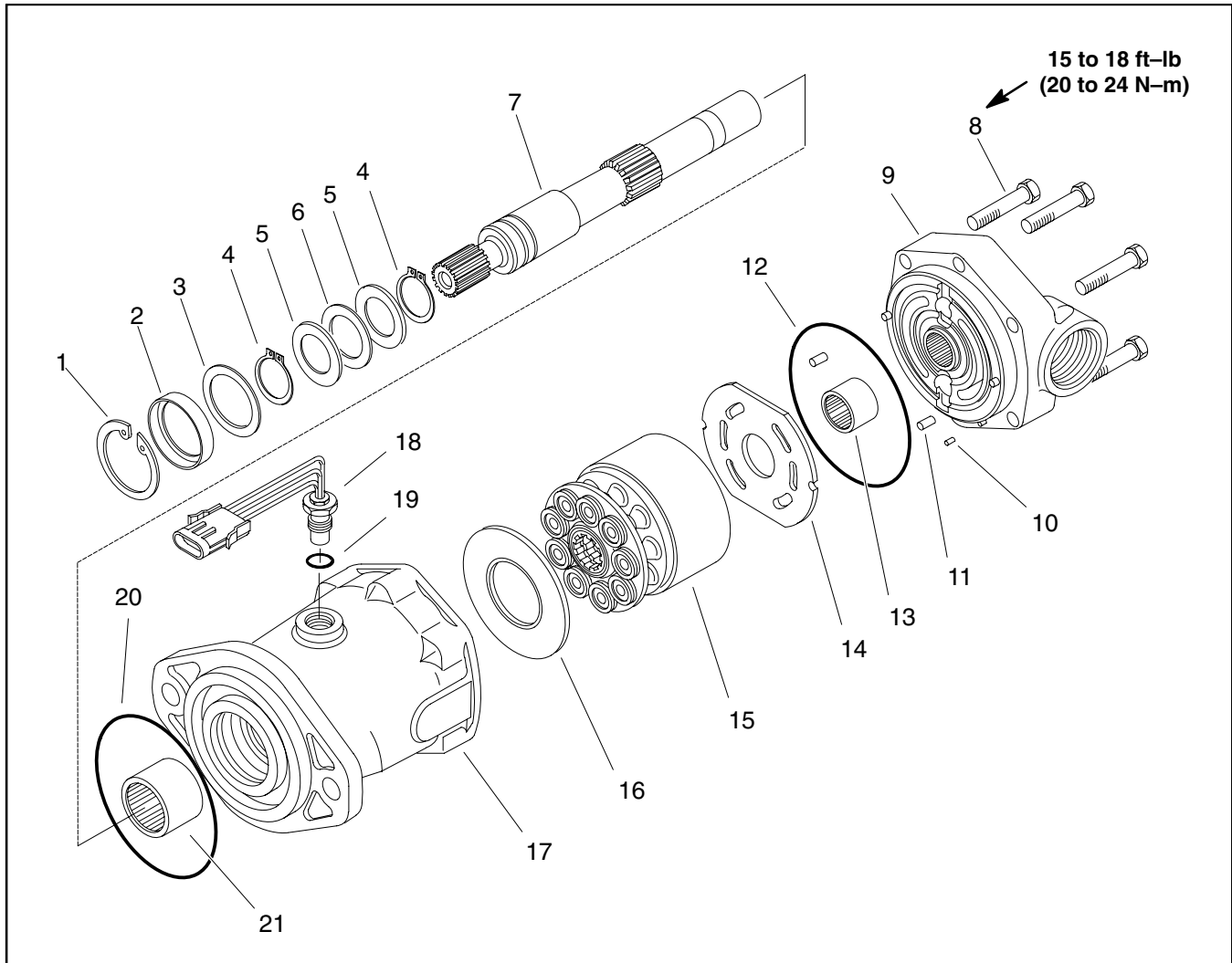

Figure 37

- |                        |                        |                             |
|------------------------|------------------------|-----------------------------|
| 1. Retaining ring      | 8. Cap screw (6 used)  | 15. Rotating kit            |
| 2. Shaft seal          | 9. Back plate          | 16. Cam plate insert        |
| 3. Washer              | 10. Dowel pin          | 17. Housing                 |
| 4. Retaining ring      | 11. Dowel pin (3 used) | 18. Speed sensor (RH wheel) |
| 5. Thrust bearing race | 12. O-ring             | 19. O-ring                  |
| 6. Thrust bearing      | 13. Needle bearing     | 20. O-ring                  |
| 7. Drive shaft         | 14. Valve plate        | 21. Needle bearing          |

**NOTE:** The wheel motors used on the Multi Pro 5600 are very similar. The major difference is the speed sensor installed in the right side wheel motor. Service of the left and right motors requires the same procedure.

**NOTE:** For service of the wheel motors, see the Eaton Model 74318 and 74348 Piston Motors: Fixed Displacement, Valve Plate Design Repair Information at the end of this chapter.

**NOTE:** For information on speed sensor installation, see Traction Speed Sensor in the Service and Repairs section of Chapter 5 – Electrical System.

This page is intentionally blank.

# Spray Pump Drive Motor

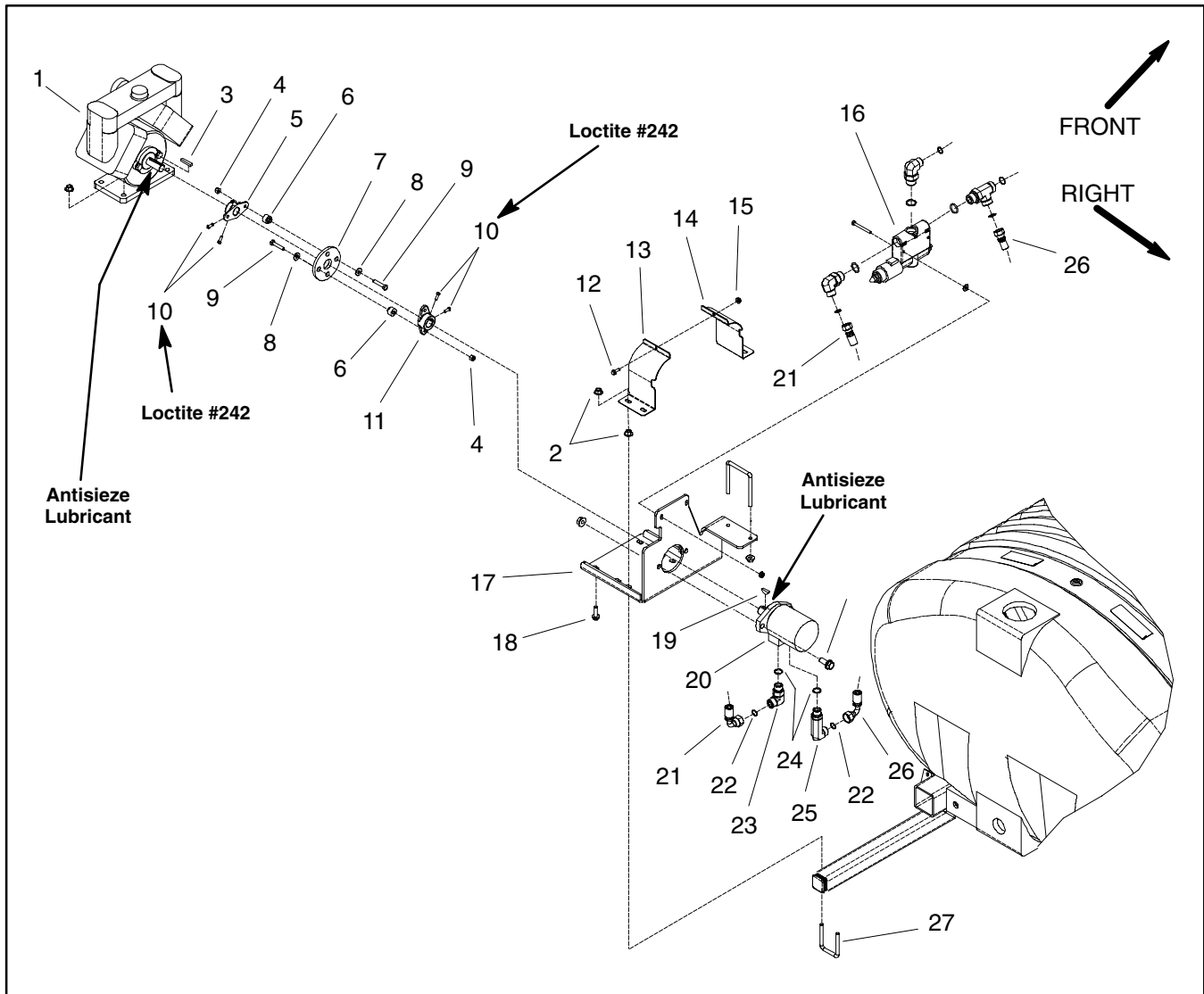

Figure 38

- |   |   |  |
|---|---|--|
| <ul style="list-style-type: none"> <li>1. Spray pump assembly</li> <li>2. Flange nut</li> <li>3. Square key</li> <li>4. Lock nut</li> <li>5. Pump hub</li> <li>6. Coupler spacer</li> <li>7. Rubber coupling</li> <li>8. Flat washer</li> <li>9. Cap screw</li> </ul> | <ul style="list-style-type: none"> <li>10. Set screw</li> <li>11. Hydraulic motor hub</li> <li>12. Flange head screw</li> <li>13. Rear guard plate</li> <li>14. Front guard plate</li> <li>15. Flange nut</li> <li>16. PWM Valve</li> <li>17. Pump mount bracket</li> <li>18. Flange head screw (4 used)</li> </ul> | <ul style="list-style-type: none"> <li>19. Woodruff key</li> <li>20. Hydraulic motor</li> <li>21. Hydraulic hose (from PWM CF port)</li> <li>22. O-ring</li> <li>23. Hydraulic 90° fitting (short)</li> <li>24. O-ring</li> <li>25. Hydraulic 90° fitting (long)</li> <li>26. Hydraulic hose (to T fitting on PWM)</li> <li>27. U-bolt (2 used)</li> </ul> |
|---|---|--|

## Removal (Fig. 38)

1. Park machine on a level surface, stop engine, engage parking brake, and remove key from the ignition switch.



2. Operate all hydraulic controls to relieve hydraulic system pressure.

3. Read the General Precautions for Removing and Installing Hydraulic System Components at the beginning of the Service and Repairs section of this chapter.

4. Remove flange head screw and flange nut that secure front and rear guard plate. Remove four (4) flange nuts that retain guard plates to pump mount bracket. Remove guard plates from machine.

5. Label all hydraulic connections to ease reassembly. Clean hydraulic hose ends prior to disconnecting the hoses from hydraulic motor.

6. Disconnect hydraulic hoses from motor. Allow hoses to drain into a suitable container.

7. Put caps or plugs on disconnected hoses and fittings to prevent contamination.

8. Remove lock nuts, flat washers, cap screws, and coupler spacers that secure rubber coupling to hydraulic motor hub.

9. Remove two (2) flange head screws and flange nuts that secure hydraulic motor to pump mount bracket.

10. Remove hydraulic motor from machine.

11. If needed, loosen set screws in hydraulic motor hub. Pull hub from motor shaft. Locate and remove woodruff key from motor shaft. Remove set screws from hub. Clean threads of set screws and hub.

12. If hydraulic fitting removal is needed, note orientation of hydraulic fittings before removing fittings from motor.

## Installation (Fig. 38)

1. If removed, lubricate new o-rings and install hydraulic fittings to motor.

2. If motor hub was removed, apply anti-seize lubricant to motor shaft. Install woodruff key in shaft and slide hub onto motor shaft.

3. Position motor on pump mounting bracket and install flange head screws and flange nuts to motor and mounting bracket. Leave fasteners loose.

4. Place coupling spacers into rubber coupling. Install cap screws, flat washers, and lock nuts to secure rubber coupling to motor hub. Make sure that cap screw threads extend through lock nut.

5. Secure motor to mounting bracket by tightening flange head screws and flange nuts.

6. If motor hub was removed, apply Loctite #242 (or equivalent) to threads of motor hub set screws. Install set screws into hub to secure hub to motor shaft.

7. Lubricate new o-rings and install hydraulic hoses to correct hydraulic fittings on motor.

8. Position front and rear guard plates to pump mount bracket. Install and tighten flange head screw and flange nut to guard plates. Install flange nuts to secure guard plates to pump mount bracket.

9. Check fluid level in hydraulic oil reservoir and adjust as required (see Operator's Manual).

10. Properly fill hydraulic system (see Charge Hydraulic System in the Service and Repairs section of this chapter).

11. Stop engine and check for hydraulic oil leaks. Check hydraulic reservoir oil level.

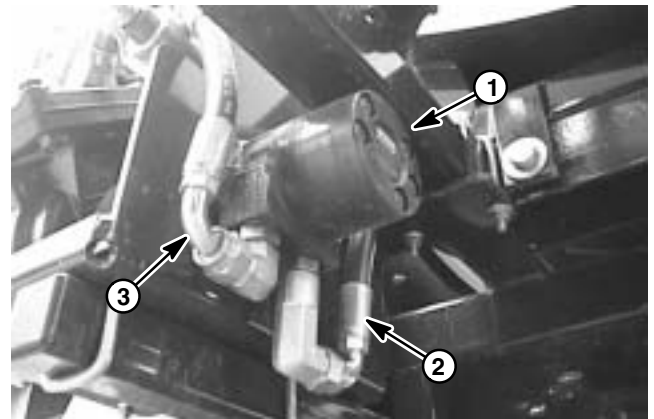

Figure 39

1. Spray pump drive motor
2. Hydraulic hose (from PWM CF port)
3. Hydraulic hose (to PWM EX port)

# Spray Pump Drive Motor Service

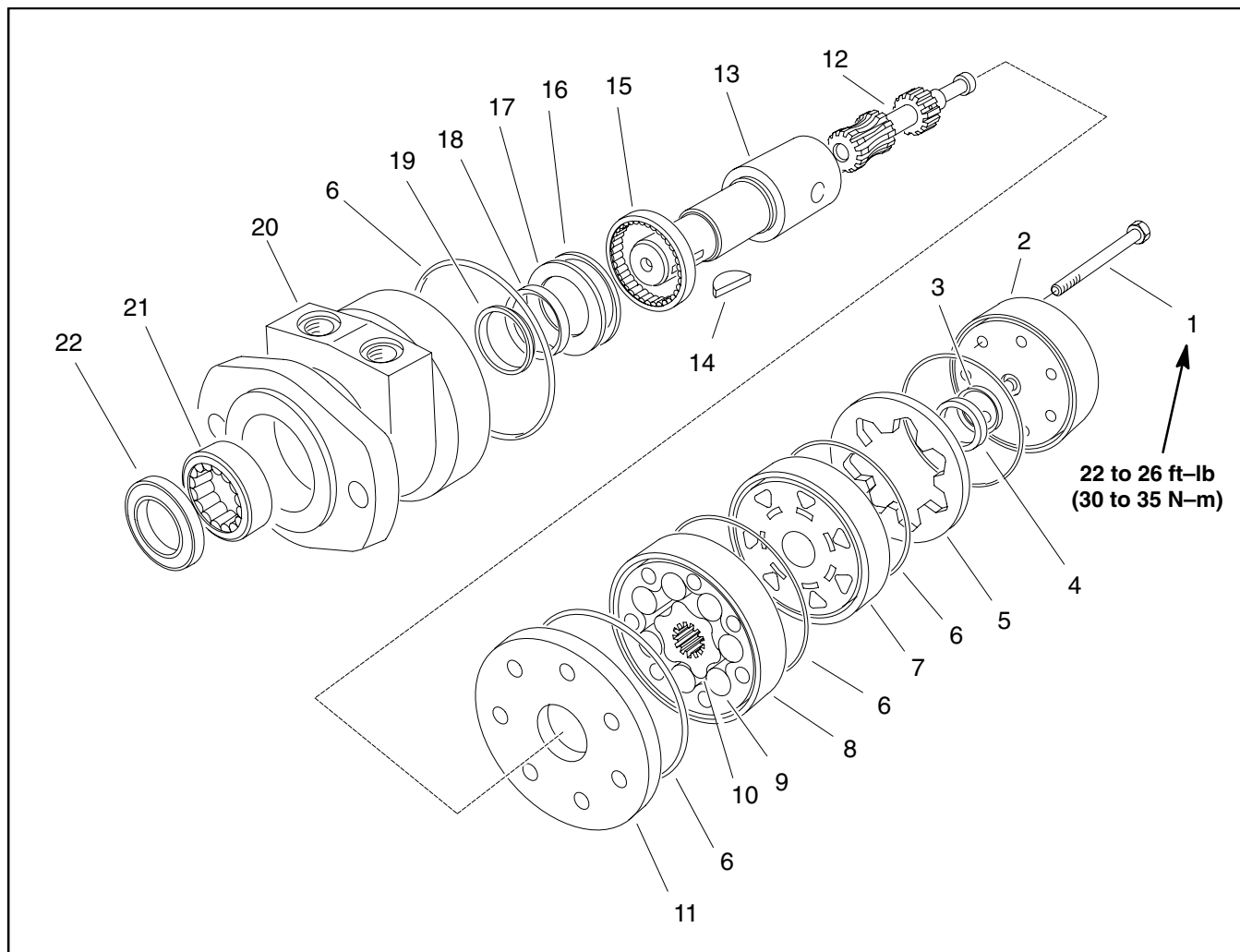

Figure 40

- |                       |                  |                    |
|-----------------------|------------------|--------------------|
| 1. Cap screw (5 used) | 9. Vane          | 16. Thrust bearing |
| 2. End cover          | 10. Rotor        | 17. Thrust washer  |
| 3. Commutator seal    | 11. Wear plate   | 18. Inner seal     |
| 4. Commutator         | 12. Drive link   | 19. Backup washer  |
| 5. Commutator ring    | 13. Shaft        | 20. Housing        |
| 6. Ring seal          | 14. Woodruff key | 21. Bearing        |
| 7. Manifold           | 15. Bearing      | 22. Seal           |
| 8. Stator             |                  |                    |

**NOTE:** For service of the spray pump drive motor, see the Parker Torqlink™ Service Procedure at the end of this chapter.

## Relief Valve

### Removal

1. Park machine on a level surface, stop engine, engage parking brake, and remove key from the ignition switch.



2. Operate all hydraulic controls to relieve hydraulic system pressure.
3. Read the General Precautions for Removing and Installing Hydraulic System Components at the beginning of the Service and Repairs section of this chapter.
4. Disconnect hose assembly from hydraulic fitting at bottom of relief valve body. Allow hose to drain into a suitable container.
5. Unscrew relief valve body from hydraulic adapter in side of piston pump.
6. If needed, remove hydraulic fitting from bottom of relief valve body.

### Installation

1. Lubricate new o-rings with clean hydraulic fluid.
2. If removed, install hydraulic fitting into bottom of relief valve body.
3. Secure valve body to the hydraulic adapter in side of piston pump.
4. Install hydraulic hose to hydraulic fitting at bottom of relief valve body. Tighten hose connections.

### Disassembly

1. Unscrew relief valve cartridge from the relief valve body. Remove o-ring and back-up ring.
2. Inspect ports of the relief valve body for damaged sealing surfaces or threads and contamination.
3. Inspect relief valve cartridge for damaged sealing surfaces and contamination.

A. Contamination may cause valves to stick or hang up. Contamination can become lodged in small valve orifices or seal areas causing malfunction.

B. If sealing surfaces appear pitted or damaged, the hydraulic system may be over heating or there may be water in the hydraulic system.



4. Clean relief valve cartridge using clean mineral spirits to flush out any contamination. Submerge cartridge in clean mineral spirits to flush out contamination. Particles as fine as talcum powder can affect the operation of relief valve. Use compressed air for cleaning.

### Reassembly

1. Lubricate new o-ring and back-up ring with clean hydraulic fluid. Install o-ring and back-up ring to the relief valve cartridge.
2. Carefully thread relief valve cartridge into the relief valve body. The valve should go in easily without binding. Torque cartridge to 190 in-lb (21.4 N-m).
3. Lubricate new O-rings with clean hydraulic fluid. Connect hydraulic fittings and O-rings to the relief valve body.

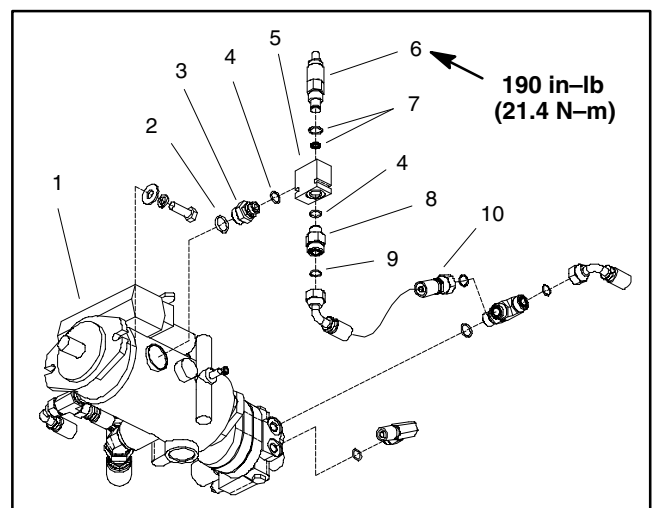

Figure 41

- |                      |                      |
|----------------------|----------------------|
| 1. Pump assembly     | 6. Relief cartridge  |
| 2. O-ring            | 7. Seal kit          |
| 3. Hydraulic adapter | 8. Hydraulic fitting |
| 4. O-ring            | 9. O-ring            |
| 5. Relief valve body | 10. Hydraulic hose   |

## Pulse Width Modulated (PWM) Valve

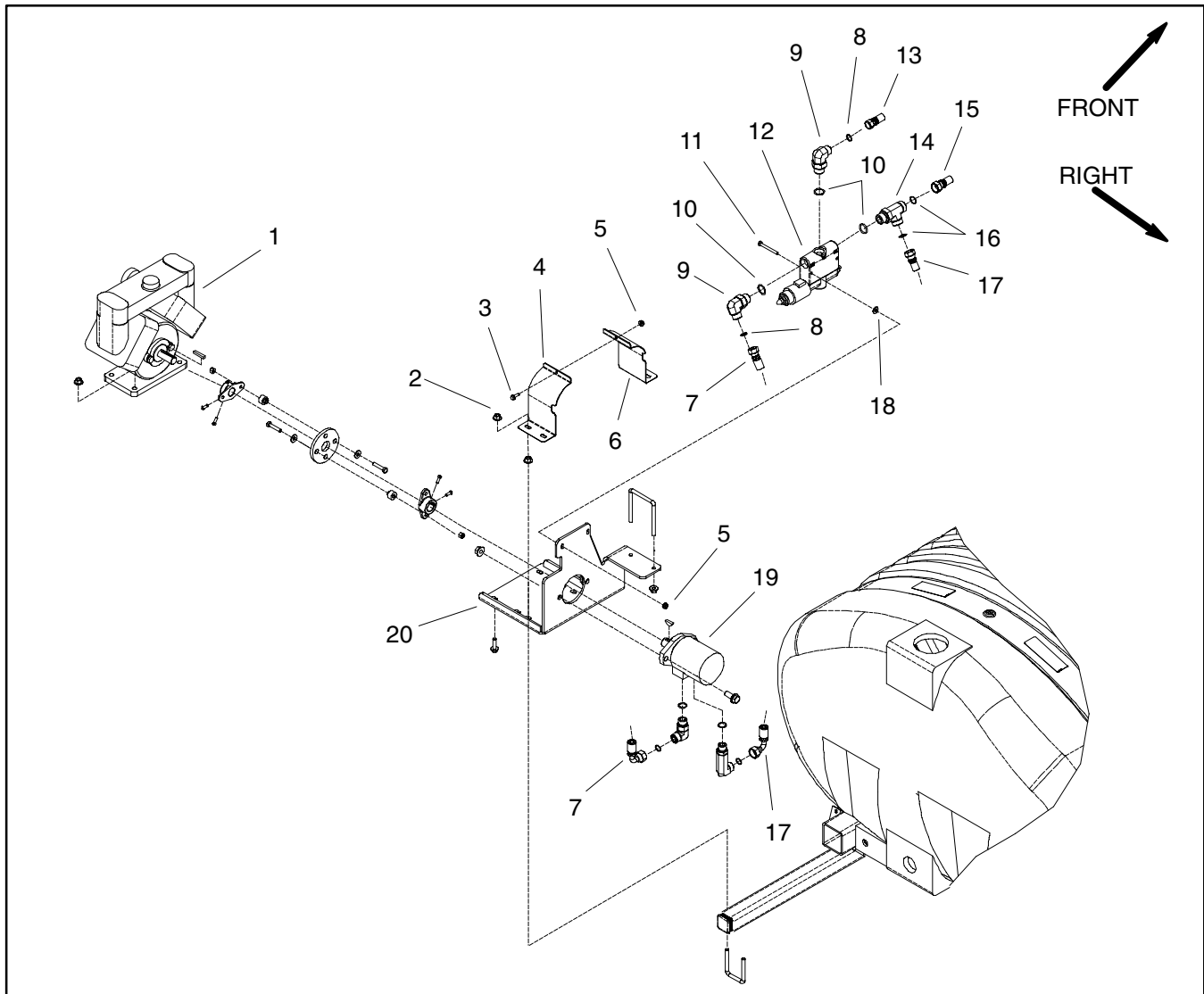

Figure 42

- |                                  |                                     |                                       |
|----------------------------------|-------------------------------------|---------------------------------------|
| 1. Spray pump assembly           | 8. O-ring                           | 15. Hydraulic hose (to oil cooler)    |
| 2. Flange nut                    | 9. Hydraulic fitting                | 16. O-ring                            |
| 3. Flange head screw             | 10. O-ring                          | 17. Hydraulic hose (motor to PWM tee) |
| 4. Rear guard plate              | 11. Cap screw (2 used)              | 18. Flat washer (2 used)              |
| 5. Flange nut (3 used)           | 12. PWM Valve                       | 19. Hydraulic motor                   |
| 6. Front guard plate             | 13. Hydraulic hose (from gear pump) | 20. Pump mount bracket                |
| 7. Hydraulic hose (PWM to motor) | 14. Tee fitting                     |                                       |

The Pulse Width Modulated (PWM) Valve is used on the Multi Pro 5600 to control gear pump flow to the spray pump hydraulic motor. Electrical current to the PWM Valve solenoid coil affects the internal spool setting of the Valve and thus the hydraulic flow to the spray pump motor. Component parts for the PWM Valve are not available.

For information on PWM Valve solenoid testing, see Pulse Width Modulated (PWM) Valve Solenoid in the Component Testing section of Chapter 5 – Electrical System.

**IMPORTANT: Correct operation of the PWM Valve depends on precise assembly and adjustment. No disassembly or adjustment of the PWM Valve is recommended.**



## Removal (Fig. 38)

1. Park machine on a level surface, stop engine, engage parking brake, and remove key from the ignition switch.



2. Operate all hydraulic controls to relieve hydraulic system pressure.

3. Read the General Precautions for Removing and Installing Hydraulic System Components at the beginning of the Service and Repairs section of this chapter.

4. Label all hydraulic connections to ease reassembly. Clean hydraulic hose ends prior to disconnecting the hoses from PWM Valve.

5. Disconnect four (4) hydraulic hoses from fittings in PWM Valve. Allow hoses to drain into a suitable container.

6. Put caps or plugs on disconnected hoses and fittings to prevent contamination.

7. Disconnect PWM Valve solenoid connector from machine wiring harness (Fig. 43).

8. Remove two (2) cap screws and flange nuts that secure PWM Valve to pump mount bracket. Locate and retrieve two (2) flat washers from between PWM Valve and pump mount bracket. Remove PWM Valve from machine.

## Installation (Fig. 38)

1. Place two (2) cap screws into PWM Valve mounting holes. Install flat washer on screws and position Valve to pump mount bracket. Install and tighten flange nuts to secure PWM Valve to bracket.

2. Remove caps and plugs from hydraulic hoses and fittings. Lubricate new o-rings and install hydraulic hoses to fittings in PWM Valve.

3. Plug PWM Valve solenoid connector into machine wiring harness.

4. Check fluid level in hydraulic oil reservoir and adjust as required (see Operator's Manual).

5. Operate machine and inspect for leaks.

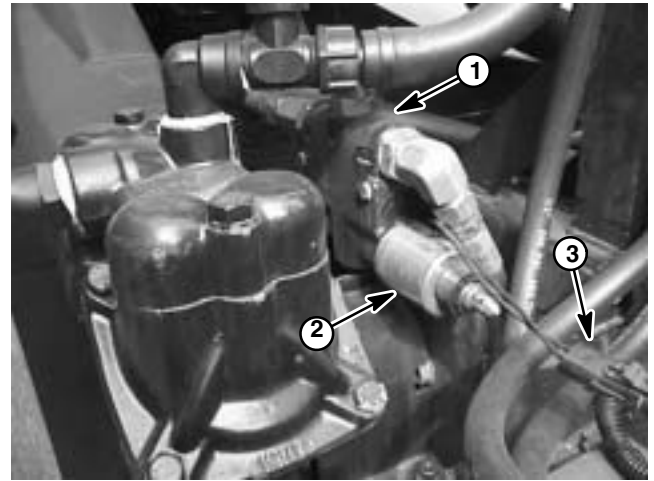

Figure 43

1. PWM Valve  
2. Solenoid

3. Solenoid connector

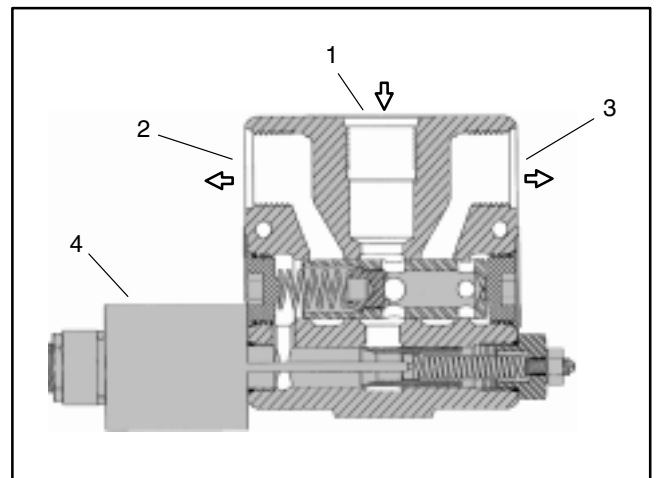

Figure 44

1. IN port (from gear pump)  
2. CF port (to motor)

3. EX port (to oil cooler)  
4. Solenoid coil

# Steering Control Valve

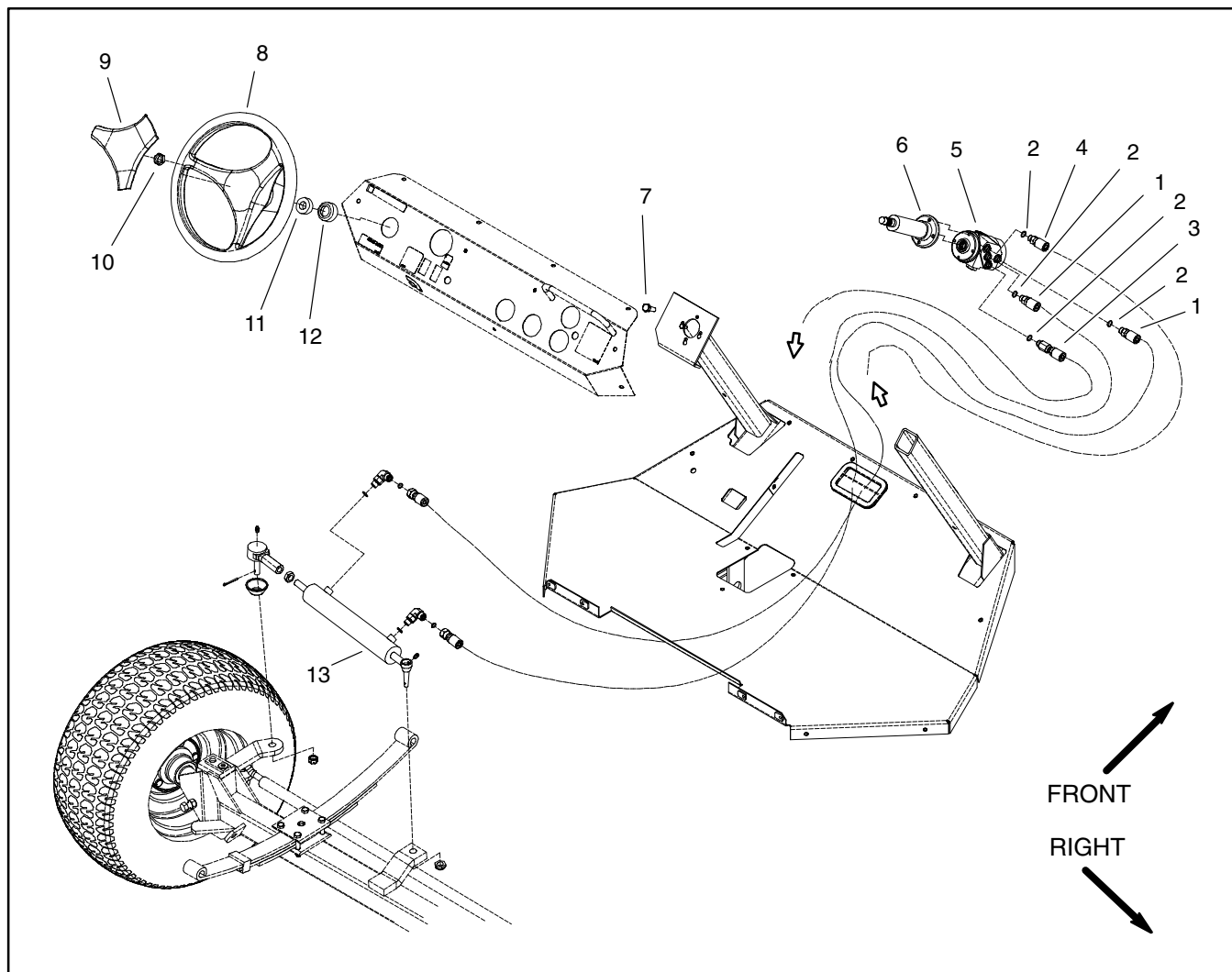

Figure 45

- |  |                         |                       |
|--|-------------------------|-----------------------|
| 1. Hydraulic hose (to steering cylinder) | 6. Steering column      | 10. Nut               |
| 2. O-ring                                | 7. Cap screw (4 used)   | 11. Dust cover        |
| 3. Hydraulic hose (to oil cooler)        | 8. Steering wheel       | 12. Steering seal     |
| 4. Hydraulic hose (from pump)            | 9. Steering wheel cover | 13. Steering cylinder |
| 5. Steering control valve                |                         |                       |

## Removal (Fig. 45)

1. Park the machine on a level surface, engage parking brake, and stop engine. Remove key from the ignition switch.



2. Operate all hydraulic controls to relieve hydraulic system pressure.

3. Read the General Precautions for Removing and Installing Hydraulic System Components at the beginning of the Service and Repairs section of this chapter.

4. Label all hydraulic connections for reassembly purposes. Clean hydraulic hose ends prior to disconnecting the hoses.

5. Remove fasteners that secure dash panel to front hood (Fig. 47). Front edge of panel is secured with four (4) screws and weldnuts. Sides of panel are fastened with four (4) screws and flange nuts. Carefully slide dash panel up steering column to allow access to steering control valve.

6. Disconnect hydraulic hoses connected to the steering control valve. Allow hoses to drain into a suitable container. Cap or plug openings of control valve and hoses to prevent contamination.

7. Support steering control valve to prevent it from falling during removal.

8. Loosen and remove four (4) cap screws that secure steering column and steering control valve to machine frame.

9. Slide steering valve from control column. Remove control valve from machine.

## Installation (Fig. 45)

1. Slide steering control valve onto steering column. Secure steering column and control valve to frame with four (4) cap screws.

2. Remove caps and plugs from disconnected hoses and fittings.

3. Lubricate new o-rings and connect hydraulic hoses to steering control valve (Fig. 46). Tighten hose connections.

4. Position dash panel to front hood and secure with fasteners (Fig. 47).

5. Check fluid level in hydraulic oil reservoir and adjust as required (see Operator's Manual).

6. After assembly is completed, operate steering cylinder to verify that hydraulic hoses and fittings are not contacted by anything and that there are no leaks.

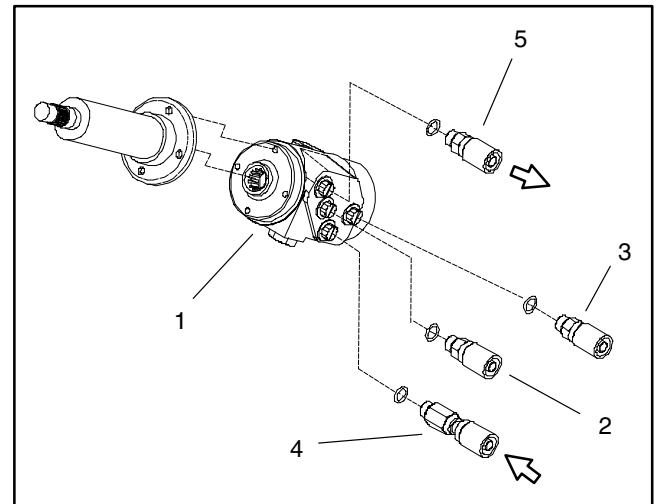

Figure 46

- |                           |                             |
|---------------------------|-----------------------------|
| 1. Steering control valve | 4. Hyd hose (from pump)     |
| 2. Hyd hose (left turn)   | 5. Hyd hose (to oil cooler) |
| 3. Hyd hose (right turn)  |                             |

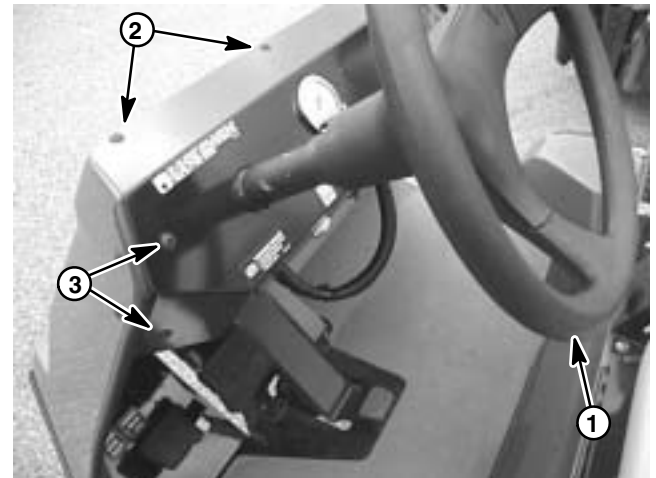

Figure 47

- |                           |                     |
|---------------------------|---------------------|
| 1. Steering wheel         | 3. Dash side screws |
| 2. Dash front edge screws |                     |

# Steering Control Valve Service

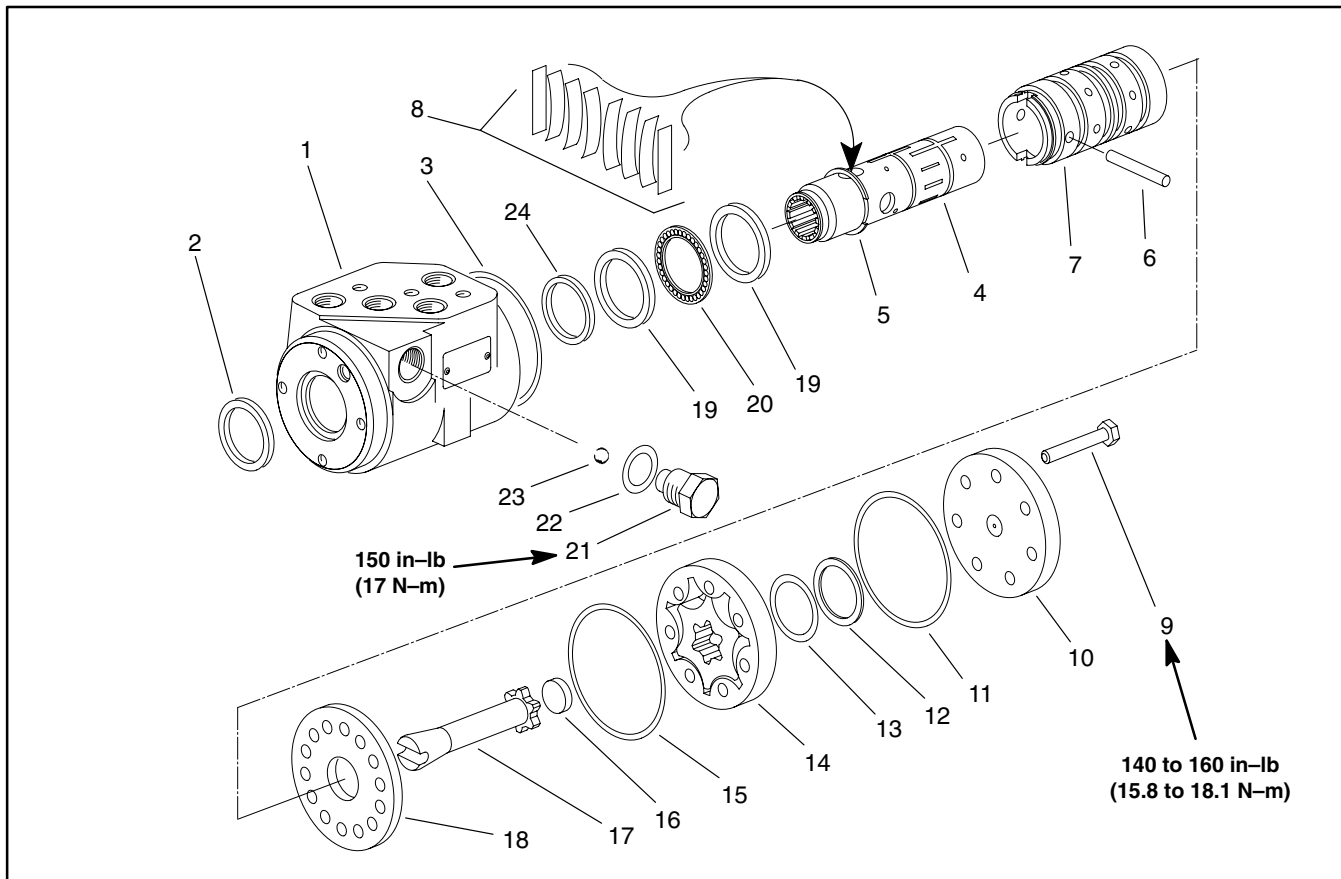

Figure 48

- |                              |                       |                    |
|------------------------------|-----------------------|--------------------|
| 1. Steering valve housing    | 9. Cap screw (7 used) | 17. Geroter drive  |
| 2. Dust seal                 | 10. End cap           | 18. Wear plate     |
| 3. O-ring                    | 11. O-ring            | 19. Bearing race   |
| 4. Spool                     | 12. Seal ring         | 20. Thrust bearing |
| 5. Spring retaining ring     | 13. O-ring            | 21. Plug           |
| 6. Pin                       | 14. Geroter           | 22. O-ring         |
| 7. Sleeve                    | 15. O-ring            | 23. Check ball     |
| 8. Centering springs/spacers | 16. Spacer            | 24. Quad seal      |

## Disassembly

**NOTE:** Cleanliness is extremely important when repairing hydraulic components. Work in a clean area. Before disassembly, drain the oil, then plug the ports and thoroughly clean the exterior. During repairs, always protect machined surfaces.

1. Remove the seven cap screws from the steering valve assembly.
2. Remove end cap, geroter, spacer, geroter drive, wear plate, seal ring, and o-rings (Items 11, 13, and 15) from housing (Fig. 48).
3. Remove the plug, o-ring, and check ball from the housing.
4. Slide the spool and sleeve assembly from the housing.
5. Remove the thrust bearing and bearing races (2).
6. Remove the quad seal.
7. Use a small blade screwdriver to carefully pry the dust seal from the housing. Be careful to not damage the dust seal seat in the housing.
8. Remove the pin (Item 6) that holds the spool and sleeve together.
9. Carefully slide the spool out of the sleeve. The centering springs and spring retaining ring will stay with the spool as it is removed.



## CAUTION

The centering springs are under tension. Remove the retaining ring carefully.

10. Remove the spring retaining ring and centering springs from the spool.

### Reassembly

Check all mating surfaces. Replace any parts with scratches or burrs that could cause leakage. Wash all metal parts in clean solvent. Blow them dry with pressurized air. Do not wipe parts dry with paper towels or cloth. Lint in a hydraulic system will cause damage.

**NOTE:** Always use new seals and o-rings when reassembling the steering control valve.

**IMPORTANT:** During reassembly, lubricate the new seals with petroleum jelly. Also, lubricate machined surfaces and bearings with clean hydraulic oil.

1. Install the quad seal:

A. Put one of the bearing races and sleeve into the housing.

B. Together, the housing and bearing race create a groove into which the quad seal will be installed.

C. Hold the bearing race tightly against the input end of the housing by pushing on the gerotor end of the sleeve.

D. Fit the quad seal into its seat through the input end of the housing. Be sure the seal is not twisted.

E. Remove the sleeve and bearing race.

2. Lubricate and install the dust seal.

3. Install the centering springs in the spool. It is best to install the two flat pieces first. Next, install the curved pieces, three at a time.

4. Fit the retaining ring over the centering springs.

5. Apply a light coating of clean hydraulic oil to the spool and slide it into the sleeve. Be sure the centering springs fit into the notches in the sleeve.

6. Install the pin.

7. Apply a light coating of petroleum jelly to the inner edge of the dust and quad seals.

8. Put the thrust bearing and bearing races into the housing. The thrust bearing goes between the two bearing races (Fig. 49).

**IMPORTANT:** Do not damage the dust or quad seals when installing the spool and sleeve assembly.

9. Apply a light coating of clean hydraulic oil to the spool and sleeve assembly. Carefully slide the assembly into the housing.

10. Clamp the housing in a vise. Use only enough clamping force to hold the housing securely.

11. Lubricate and install a new o-ring (Item 3) in the groove in the housing.

12. Install the wear plate and align screw holes in the wear plate with threaded holes in the housing.

**NOTE:** The holes in the wear plate are symmetrical.

13. Install the gerotor drive, making sure the slot in the drive engages the pin.

14. Lubricate and install new o-ring in wear plate groove.

15. Install the gerotor and align the screw holes.

16. Lubricate and install new o-ring in gerotor ring groove.

17. Lubricate and install new o-ring and seal ring in gerotor star groove.

18. Install the spacer.

19. Install the end cap and seven (7) cap screws. Tighten the cap screws, in a crossing pattern, from 140 to 160 in-lb (15.8 to 18.1 N-m).

20. Remove the steering control unit from the vise.

21. Install the check ball and plug with o-ring. Tighten the plug to 150 in-lb (17 N-m).

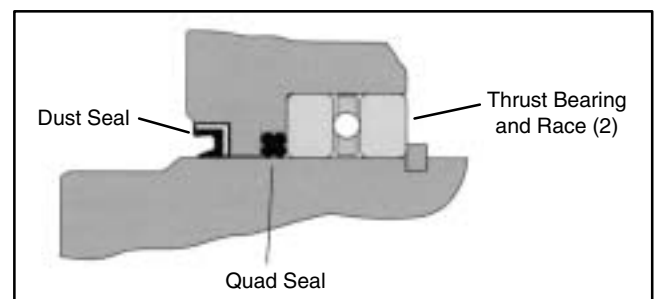

Figure 49

# Steering Cylinder

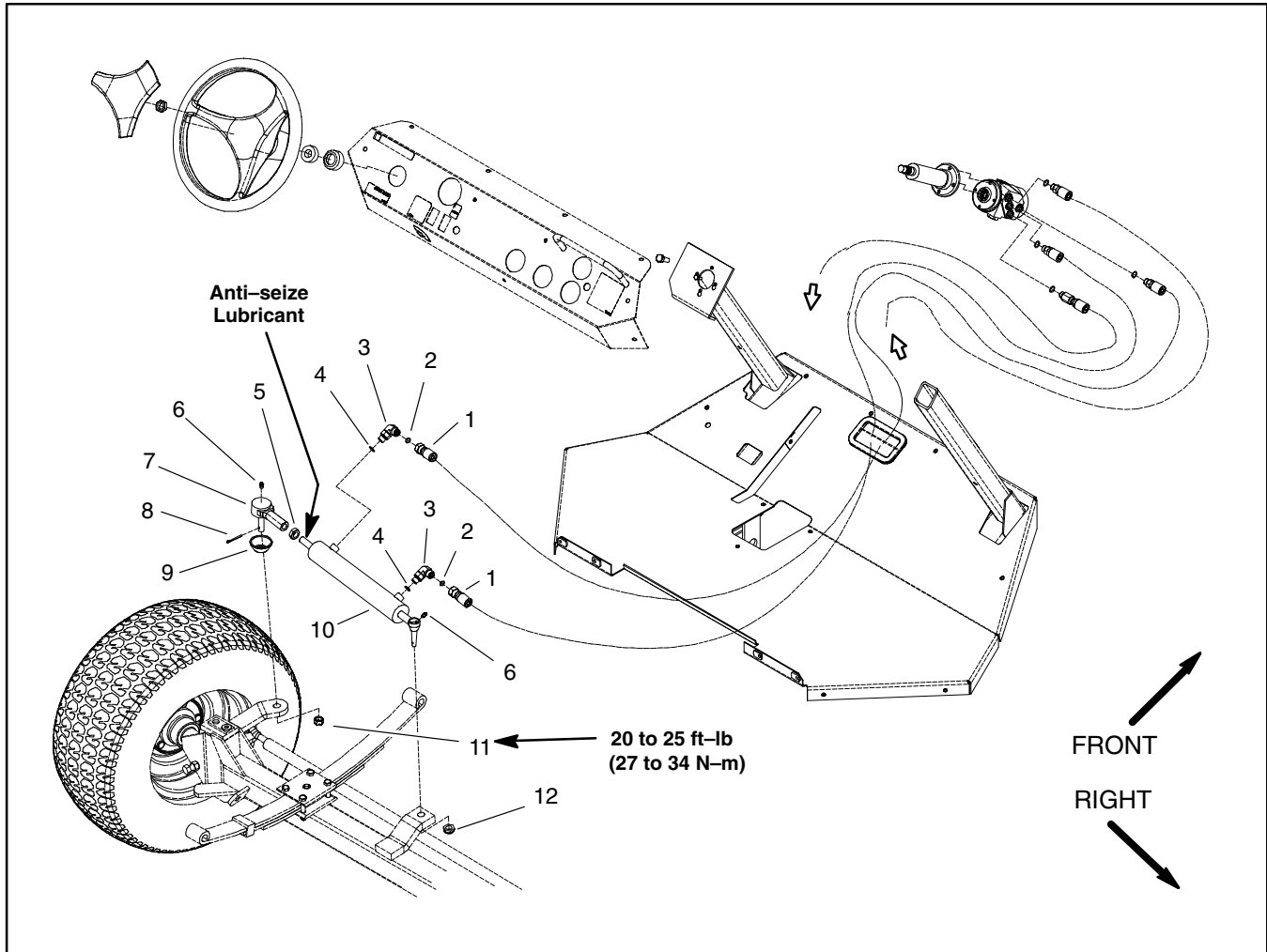

Figure 50

- 1. Hydraulic hose
- 2. O-ring
- 3. Hydraulic fitting
- 4. O-ring

- 5. Jam nut
- 6. Grease fitting
- 7. Ball joint
- 8. Cotter pin

- 9. Rod end seal
- 10. Steering cylinder
- 11. Slotted hex nut
- 12. Lock nut

## Removal (Fig. 50)

1. Park the machine on a level surface, engage the parking brake, and stop the engine. Remove the key from the ignition switch.



2. Operate all hydraulic controls to relieve hydraulic system pressure.

3. Read the General Precautions for Removing and Installing Hydraulic System Components at the beginning of the Service and Repairs section of this chapter.

4. Label all hydraulic connections for reassembly. Clean hydraulic hose ends prior to disconnecting the hoses from steering cylinder.

5. Disconnect hydraulic hoses from steering cylinder (Fig. 51). Allow hoses to drain into a suitable container.

6. Put caps or plugs on disconnected hoses and fittings to prevent contamination.

7. Remove lock nut that secures the barrel end of the steering cylinder to the front axle.

8. Remove cotter pin and hex slotted nut that secure the shaft end of the steering cylinder to the left side front axle spindle.

9. Remove steering cylinder from machine.

10. If ball joint requires removal from cylinder shaft, count number of revolutions it takes to remove from shaft so ball joint can be re-installed without affecting steering.

## Installation (Fig. 50)

1. If ball joint was removed from cylinder shaft, apply anti-seize lubricant to threads of cylinder shaft. Install ball joint onto shaft the same number of revolutions needed to remove ball joint. Secure ball joint with jam nut.

2. Place rod end seal on cylinder shaft ball joint. Insert rod ends of cylinder down into attachment points on the left side front axle spindle and front axle.

3. Secure shaft end of cylinder to the front axle spindle with slotted hex nut. Torque hex nut from 20 to 25 ft-lb (27 to 34 N-m). Install cotter pin.

4. Secure barrel end of cylinder to the front axle with locking nut.

5. Remove caps and plugs from disconnected hoses and fittings.

6. Lubricate new o-rings and connect hydraulic hoses to steering cylinder (Fig. 51). Tighten hose connections.

7. Check fluid level in hydraulic oil reservoir and adjust as required (see Operator's Manual).

8. After assembly is completed, operate steering cylinder to verify that hydraulic hoses and fittings are not contacted by anything and that there are no leaks. Also, make sure that a clockwise rotation of the steering wheel makes a right turn.

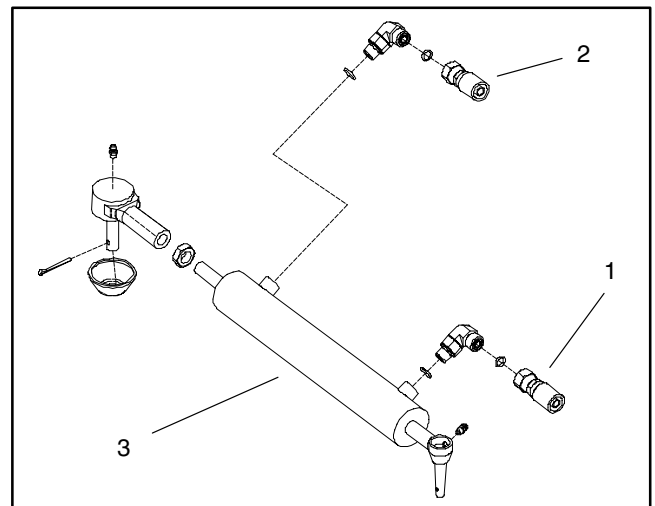

Figure 51

1. Hose from steering control R port
2. Hose from steering control L port
3. Steering cylinder

## Steering Cylinder Service

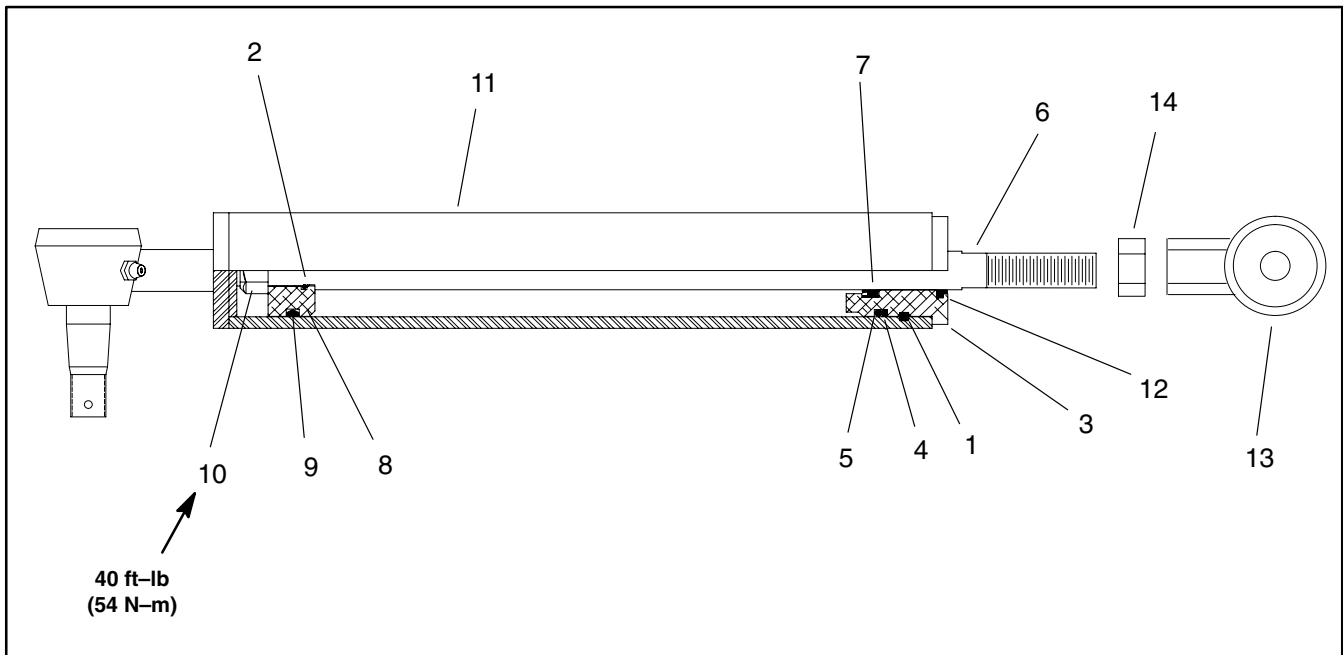

Figure 52

- |                   |              |                |
|-------------------|--------------|----------------|
| 1. Retaining ring | 6. Shaft     | 11. Barrel     |
| 2. O-ring         | 7. Rod seal  | 12. Dust seal  |
| 3. Head           | 8. Piston    | 13. Ball joint |
| 4. Backup ring    | 9. Uni-ring  | 14. Jam nut    |
| 5. O-ring         | 10. Lock nut |                |



### Disassembly (Fig. 52)

1. Remove oil from the steering cylinder into a drain pan by slowly pumping the cylinder shaft. Plug both ports and clean the outside of the cylinder.

**IMPORTANT: Prevent damage when clamping the hydraulic cylinder into a vise. Do not close vise enough to distort the barrel.**

2. Mount end of steering cylinder in a vise. Remove retaining ring that secures head into barrel.

3. Remove plugs from ports. Extract shaft, head, and piston by carefully twisting and pulling on the shaft.

**IMPORTANT: Do not clamp vise jaws against the shaft surface. Protect shaft surface before mounting in a vise.**

4. Mount shaft securely in a vise by clamping on the end of the shaft. Remove lock nut and piston from the shaft. Slide head off the shaft.

5. Remove Uni-ring and o-ring from the piston.

6. Remove o-ring, back-up ring, rod seal, and dust seal from the head.

### Reassembly (Fig. 52)

1. Make sure all parts are clean before reassembly.

2. Coat new o-rings, Uni-ring, rod seal, and back-up ring with clean hydraulic oil.

A. Install Uni-ring and o-ring to the piston.

B. Install o-ring, back-up ring, rod seal, and dust seal to the head.

**IMPORTANT: Do not clamp vise jaws against the shaft surface. Protect shaft surface before mounting in a vise.**

3. Mount shaft securely in a vise by clamping on the end of the shaft.

A. Coat shaft with a light coat of clean hydraulic oil.

B. Slide head assembly onto the shaft. Install piston and lock nut onto the shaft. Torque lock nut 40 ft-lb (54 N-m) to secure assembly.

C. Remove shaft from the vise.

**IMPORTANT: Prevent damage when clamping the hydraulic cylinder into a vise. Do not close vise enough to distort the barrel.**

4. Mount end of the barrel in a vise.

5. Coat all internal parts with a light coat of clean hydraulic oil. Slide piston, shaft, and head assembly into the barrel being careful not to damage the seals.

6. Secure head into the barrel with retaining ring.

# Oil Cooler

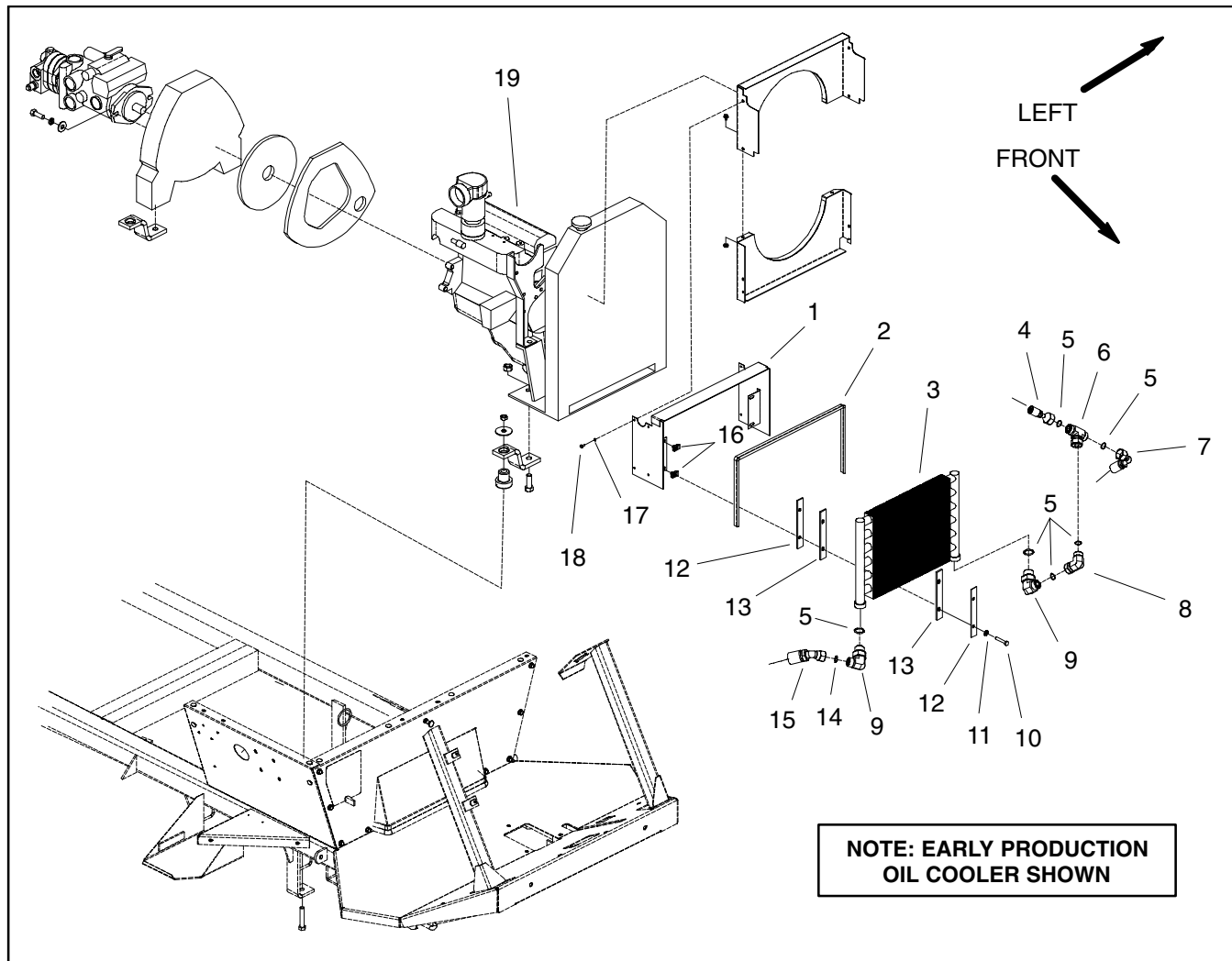

Figure 53

- |                                    |                             |                                       |
|------------------------------------|-----------------------------|---------------------------------------|
| 1. Oil cooler shroud               | 8. 90° hydraulic fitting    | 14. O-ring                            |
| 2. Shroud trim                     | 9. 90° hydraulic fitting    | 15. Hydraulic hose (to oil reservoir) |
| 3. Oil cooler                      | 10. Cap screw (4 used)      | 16. U-nut                             |
| 4. Hydraulic hose (from steering)  | 11. Flat washer (8 used)    | 17. Lock washer                       |
| 5. O-ring                          | 12. Backing strip (4 used)  | 18. Self tapping screw                |
| 6. Hydraulic tee fitting           | 13. Armaflex strip (4 used) | 19. Engine assembly                   |
| 7. Hydraulic hose (from PWM Valve) |                             |                                       |

## Removal (Fig. 53)

1. Park the machine on a level surface, engage the parking brake, and stop the engine. Remove the key from the ignition switch.



2. Operate all hydraulic controls to relieve hydraulic system pressure.
3. Read the General Precautions for Removing and Installing Hydraulic System Components at the beginning of the Service and Repairs section of this chapter.
4. Label all hydraulic connections for reassembly. Clean hydraulic hose ends prior to disconnecting the hoses from oil cooler.
5. From under front of machine, disconnect hydraulic hoses from oil cooler. Allow hoses to drain into a suitable container.
6. Put caps or plugs on disconnected hoses and fittings to prevent contamination.
7. Remove oil cooler from machine:
  - A. On early production machines (Fig. 53), loosen and remove four (4) cap screws and flat washers that secure oil cooler to oil cooler shroud. Locate and retrieve armaflex and backing strips from front and back of oil cooler as cooler is removed from machine.
  - B. On newer production machines (Fig. 54), lift oil cooler from hooks and remove from machine.
8. Clean oil cooler with solvent. Inspect for damage.

## Installation (Fig. 53)

1. Secure oil cooler to machine:
  - A. On early production machines (Fig. 53), place armaflex and backing strips to front and back of oil cooler. Position oil cooler to shroud. Secure oil cooler to shroud with flat washers and cap screws.
  - B. On newer production machines (Fig. 54), place oil cooler onto hooks.
2. Remove caps and plugs from disconnected hoses and fittings.
3. Lubricate new o-rings and connect hydraulic hoses to oil cooler. Tighten hose connections.
4. Check fluid level in hydraulic oil reservoir and adjust as required (see Operator's Manual).
5. After assembly is completed, operate machine to verify that hydraulic hoses and fittings are not contacted by anything and that there are no leaks.

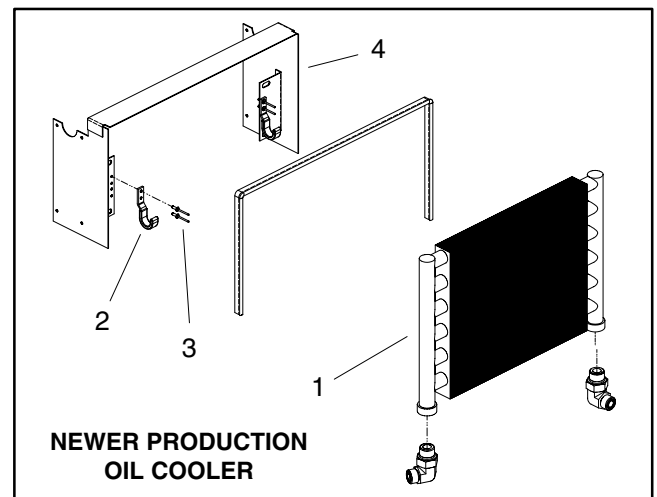

Figure 54

- |                  |                      |
|------------------|----------------------|
| 1. Oil cooler    | 3. Rivet (4 used)    |
| 2. Mounting hook | 4. Oil cooler shroud |

# Hydraulic Reservoir

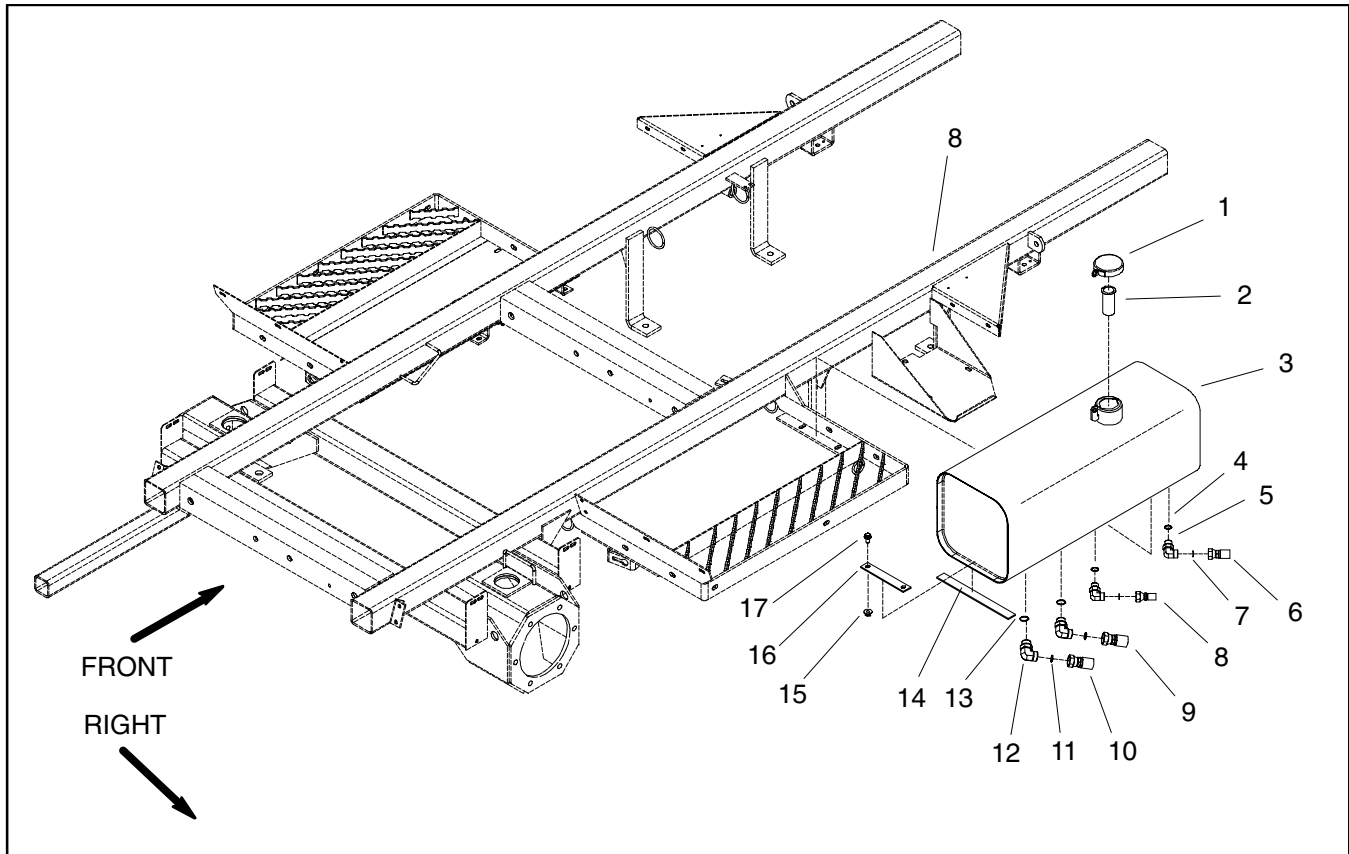

Figure 55

- |                                     |                                      |                                |
|-------------------------------------|--------------------------------------|--------------------------------|
| 1. Hydraulic reservoir cap          | 7. O-ring (2 used)                   | 13. O-ring (2 used)            |
| 2. Strainer                         | 8. Hydraulic hose (from piston pump) | 14. Cushion (2 used)           |
| 3. Hydraulic reservoir              | 9. Hydraulic hose (to piston pump)   | 15. Lock nut (4 used)          |
| 4. O-ring (2 used)                  | 10. Hydraulic hose (to gear pump)    | 16. Hold down strap (2 used)   |
| 5. Hydraulic fitting (2 used)       | 11. O-ring (2 used)                  | 17. Flange head screw (4 used) |
| 6. Hydraulic hose (from oil cooler) | 12. Hydraulic fitting (2 used)       | 18. Frame                      |

### Removal (Fig. 55)

1. Park the machine on a level surface, engage the parking brake, and stop the engine. Remove the key from the ignition switch.
2. Read the General Precautions for Removing and Installing Hydraulic System Components at the beginning of the Service and Repairs section of this chapter.
3. Disconnect one hydraulic hose from the bottom of the hydraulic reservoir to drain reservoir (see Operator's Manual).
4. Disconnect remaining hydraulic hoses from reservoir.
5. Remove hydraulic reservoir from machine using Figure 55 as a guide.

### Inspection

1. Clean hydraulic reservoir with solvent.
2. Inspect reservoir for leaks, cracks, or other damage.

### Installation (Fig. 55)

1. Install hydraulic reservoir to machine using Figure 55 as a guide.
2. Lubricate new o-rings and reconnect hydraulic hoses to reservoir (Fig. 56).
3. Fill reservoir with hydraulic fluid as required (see Operator's Manual).
4. Operate machine and inspect for leaks.

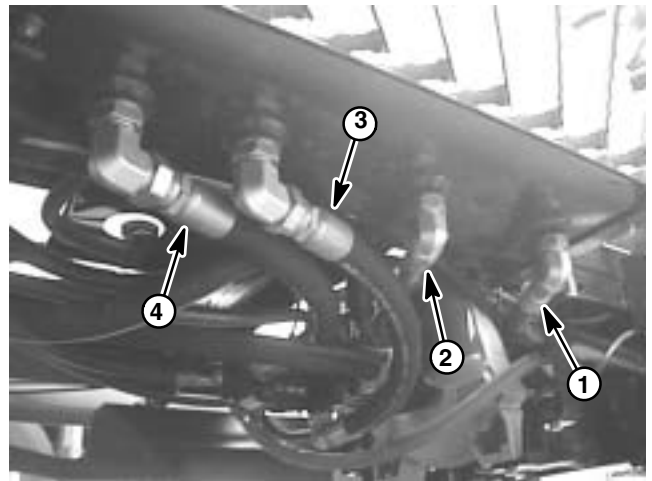

Figure 56

- |                            |                          |
|----------------------------|--------------------------|
| 1. Hose (from oil cooler)  | 3. Hose (to piston pump) |
| 2. Hose (from piston pump) | 4. Hose (to gear pump)   |

This page is intentionally blank.



# Electrical System

## Table of Contents

ELECTRICAL SCHEMATICS and ELECTRICAL HARNESS and CONNECTOR DRAWINGS	2
SPECIAL TOOLS	3
Multimeter	3
Skin-Over Grease	3
Battery Terminal Protector	3
TROUBLESHOOTING	4
Starting Problems	4
General Run Problems	5
ELECTRICAL SYSTEM QUICK CHECKS	6
Battery Test (Open Circuit Test)	6
Charging System Test	6
Neutral Switch Operation	6
COMPONENT TESTING	7
Ignition Switch	7
Neutral Switch	8
Hour Meter	8
Headlight Switch	9
Engine Low Oil Pressure Light	9
Cruise Control Switch	10
Cruise Control Coil	10
Brake Pedal Switch	11
Temperature Sender	12
Temperature Gauge	13
Traction Speed Sensor	14
Accessory Solenoid	15
Pressure Rate and Boom Actuator (Optional) Switches	16
Spray Pump, Agitation and Boom Control Switches	17
Master Boom (Foot) Switch	18
Pulse Width Modulated (PWM) Valve Solenoid	19
Manual Interface Module	20
Cruise Relay (Serial Numbers 230000400 and Above)	21
Diode Assembly (Serial Numbers 230000400 and Above)	21
SERVICE AND REPAIRS	22
Headlights	22
Traction Speed Sensor	23
Cruise Control Coil	24
Battery Storage	25
Battery Care	25
Battery Service	26

# Electrical Schematics and Electrical Harness and Connector Drawings

The electrical schematics and other electrical drawings for the Multi Pro 5600 are located in Chapter 8 – Electrical Diagrams.



# Special Tools

Order these special tools from your Toro Distributor. Some tools may also be available from a local supplier.

## Multimeter

The multimeter can test electrical components and circuits for current, resistance, or voltage.

**NOTE:** Toro recommends the use of a DIGITAL Volt-Ohm-Amp multimeter when testing electrical circuits. The high impedance (internal resistance) of a digital meter in the voltage mode will make sure that excess current is not allowed through the meter. This excess current can cause damage to circuits not designed to carry it.

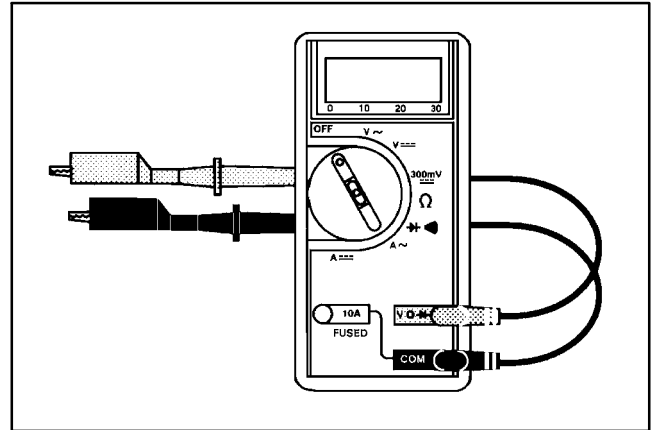

Figure 1

## Skin-Over Grease

Special non-conductive grease which forms a light protective skin to help waterproof electrical switches and contacts.

**Toro Part Number:** 505-165



Figure 2

## Battery Terminal Protector

Aerosol spray that should be used on battery terminals to reduce corrosion problems. Apply terminal protector after the battery cable has been secured to the battery terminal.

**Toro Part Number:** 107-0392



Figure 3

# Troubleshooting



## CAUTION

Remove all jewelry, especially rings and watches, before doing any electrical troubleshooting or testing. Disconnect the battery cables unless the test requires battery voltage.

For effective troubleshooting and repairs, you must have a good understanding of the electrical circuits and components used on this machine (see Electrical Schematics in Chapter 8 – Electrical Diagrams).

If the machine has any interlock switches by-passed, they must be reconnected for proper troubleshooting and safety.

## Starting Problems

Problem	Possible Causes
<p>Starter solenoid clicks, but starter will not crank (if solenoid clicks, problem is not in safety interlock system).</p>	<p>Battery charge is low.</p> <p>Battery cables are loose or corroded.</p> <p>Battery ground to frame is loose or corroded.</p> <p>Wiring at starter is faulty.</p> <p>Starter solenoid is faulty.</p> <p>Starter mounting bolts are loose or not supplying a sufficient ground for solenoid.</p> <p>Starter is faulty.</p>
<p>Nothing happens when start attempt is made.</p>	<p>Battery cables are loose or corroded.</p> <p>Battery ground cable to frame is loose or corroded.</p> <p>Battery is dead.</p> <p>Main fuse (20 amp) is open.</p> <p>Wiring to start circuit components is loose, corroded, or damaged (see Chapter 8 – Electrical Diagrams).</p> <p>Neutral switch is out of adjustment or faulty.</p> <p>Ignition switch is faulty.</p> <p>Fuse block is faulty.</p> <p>Starter solenoid is faulty.</p>

---

## Starting Problems (continued)

Problem	Possible Causes
Engine cranks, but does not start.	Ignition switch is faulty. Engine is malfunctioning (see Chapter 3 – Ford Gasoline Engine). Fuel system is malfunctioning (see Chapter 3 – Ford Gasoline Engine). Engine may be too cold.
Engine cranks (but should not) with the traction pedal out of the neutral position.	Neutral switch is out of adjustment or faulty. Neutral switch wiring is faulty (see Chapter 8 – Electrical Diagrams).

---

## General Run Problems

Problem	Possible Causes
Battery does not charge.	Wiring to the charging circuit components is loose, corroded, or damaged (see Chapter 8 – Electrical Diagrams). Alternator belt is slipping or damaged. Alternator is faulty. Battery is dead.
Engine kills during operation.	Ignition switch is faulty. Engine is malfunctioning (see Chapter 3 – Ford Gasoline Engine).

# Electrical System Quick Checks

## Battery Test (Open Circuit Test)

Use a multimeter to measure the voltage between the battery terminals.

Set the multimeter to the DC volts setting. The battery should be at a temperature of 60° to 100° F (16° to 38° C). The ignition key should be in the OFF position and all accessories turned off. Connect the positive (+) meter lead to the positive battery post and the negative (-) meter lead to the negative battery post.

**NOTE:** This test provides a relative condition of the battery. Load testing of the battery will provide additional and more accurate information.

Voltage Measured	Battery Charge Level
12.68 v (or higher)	Fully charged (100%)
12.45 v	75% charged
12.24 v	50% charged
12.06 v	25% charged
11.89 v	0% charged

## Charging System Test

This is a simple test used to determine if a charging system is functioning. It will tell you if a charging system has an output, but not its capacity.

Use a multimeter set to the DC volts setting. Connect the positive (+) meter lead to the positive battery post and the negative (-) meter lead to the negative battery post. Leave the test leads connected and record the battery voltage.

**NOTE:** Upon starting the engine, the battery voltage will drop and then should increase once the engine is running.

**NOTE:** Depending upon the condition of the battery charge and battery temperature, the charging system voltage will increase at different rates as the battery charges.

Start the engine and run at high idle (**3175 ± 25 RPM**). Allow the battery to charge for at least 3 minutes. Record the battery voltage.

Test results should be (example):

At least 0.50 volt over initial battery voltage.	
Initial Battery Voltage	= 12.30 v
Battery Voltage after 3 Minute Charge	= 12.80 v
Difference	= +0.50 v

## Neutral Switch Operation

**CAUTION**

**Do not disconnect neutral interlock switch. It is for the operator's protection. Check the operation of the switch daily for proper operation. Replace malfunctioning neutral interlock switch before operating the machine.**

Neutral switch operation is described in the Multi Pro 5600 Operator's Manual. Testing of the neutral switch is included in the Component Testing section of this Chapter.

# Component Testing

For accurate resistance and/or continuity checks, electrically disconnect the component being tested from the circuit (e.g. disconnect the ignition switch connectors before doing a continuity check on the ignition switch).

**NOTE:** See the Ford VSG – 411/413 Engine Service Manual for more component testing information.

CAUTION

**When testing electrical components for continuity with a multimeter (ohms setting), make sure that power to the circuit has been disconnected.**

## Ignition Switch

The ignition (key) switch has four positions (Accessory, Stop, Run, and Start) (Fig. 3). The switch Accessory position is not used on the Multi Pro 5600. The terminals are marked as shown in Figure 4.

### Testing

The circuitry of the ignition switch is shown in the following chart. With the use of a multimeter (ohms setting), the switch functions may be tested to determine whether continuity exists between the various terminals for each switch position.

Make sure ignition switch is off. Disconnect wire harness connectors from switch and verify continuity between switch terminals. Reconnect the harness connectors to the switch after testing.

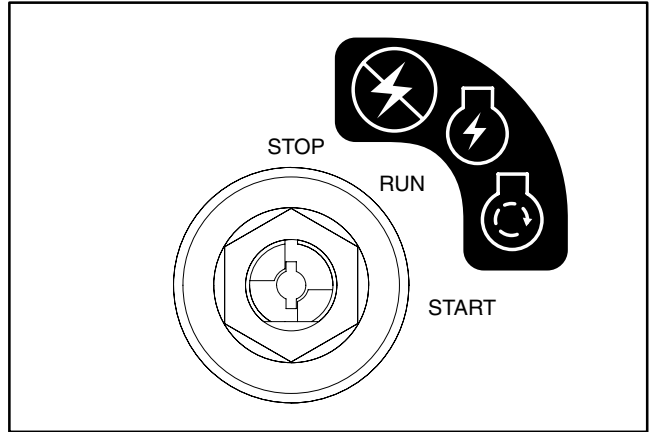

Figure 3

POSITION	CIRCUIT
STOP	NONE
RUN	BAT + IGN + ACC
START	BAT + IGN + ST

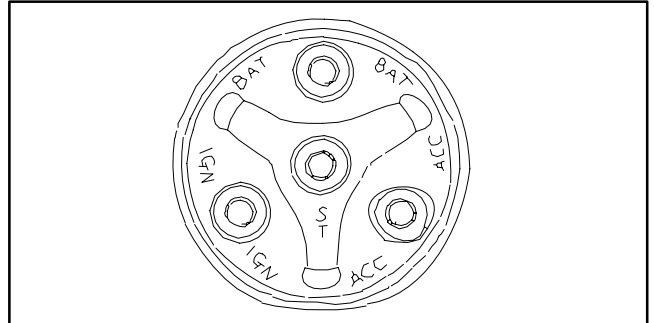

Figure 4

Electrical System

## Neutral Switch

The neutral switch is located on the top side of the piston (traction) pump (Fig. 5). The switch is closed when the traction pedal is in the neutral position and opens when the pedal is depressed in either direction (forward or reverse).

Test the switch by disconnecting the wires from the switch terminals and connecting a continuity tester across the two switch terminals. With the engine turned off, slowly push the traction pedal in a forward or reverse direction while watching the continuity tester. There should be indications that the traction neutral switch is opening and closing. Allow the traction pedal to return to the neutral position. There should be continuity across the switch terminals when the traction pedal is in the neutral position.

See Manual Servo Control Assembly in Chapter 4 – Hydraulic Systems for disassembly, reassembly and adjustment procedures for the neutral switch.

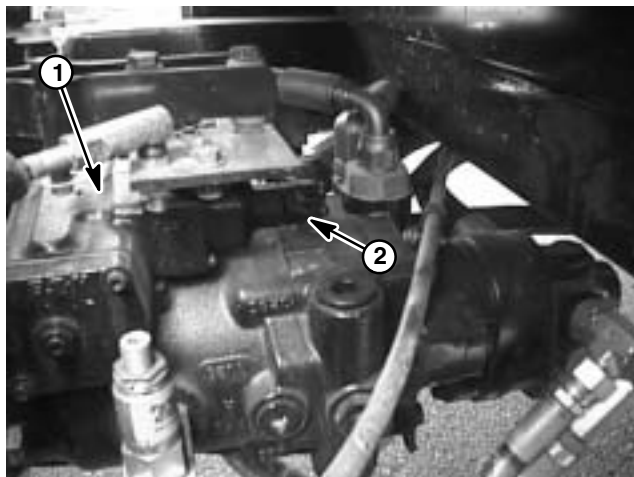

Figure 5

1. Piston (traction) pump      2. Neutral switch

## Hour Meter

The hour meter is located on the dash panel.

### Testing

1. Make sure ignition switch is off. Disconnect the harness electrical connector from the terminals on the hour meter.
2. Connect the positive (+) terminal of a 12 VDC source to the positive (+) terminal of the hour meter.
3. Connect the negative (-) terminal of the voltage source to the other terminal of the hour meter.
4. The hour meter should move 1/10 of an hour in six minutes.
5. Disconnect voltage source from the hour meter.
6. Reconnect harness to the meter terminals.

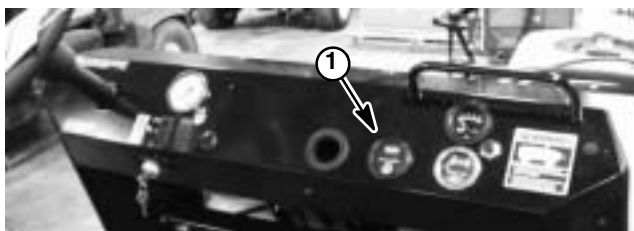

Figure 6

1. Hour meter

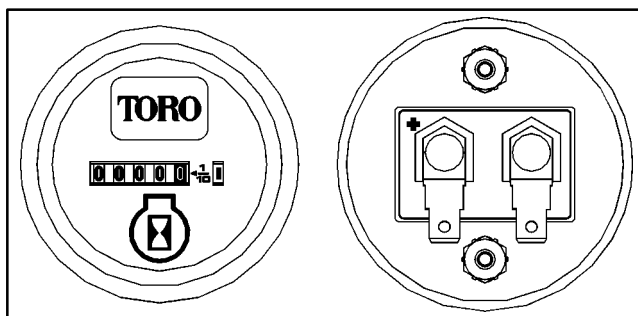

Figure 7

---

## Headlight Switch

The headlight switch is located on the dash panel (Fig. 8) and is used to turn the headlights on and off.

### Testing

1. Make sure ignition switch is off. Locate headlight switch and unplug wire harness connector from switch.
2. The switch terminals are marked as shown in Figure 9. In the ON position, continuity should exist between the two terminals. In the OFF position, there should be no continuity between the switch terminals.
3. Reconnect the harness connectors to the switch after testing.

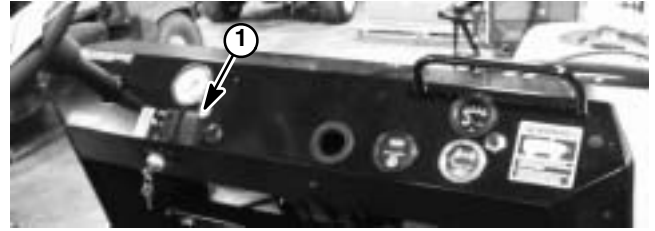

Figure 8

1. Headlight switch

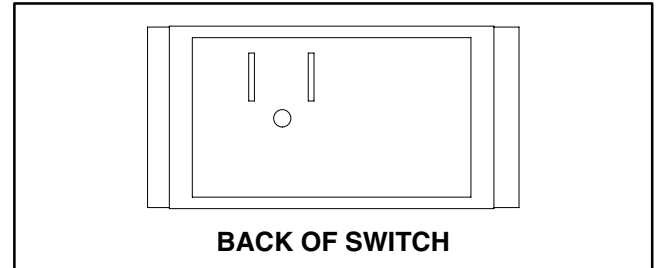

Figure 9

---

## Engine Low Oil Pressure Light

The engine low oil pressure light on the dash panel identifies unsafe engine oil pressure. An oil pressure switch on the engine near the engine oil filter activates the light.

The oil pressure light should come on when the ignition switch is in the ON position with the engine not running. Also, it should light with the engine running if the engine oil pressure drops to an unsafe level.

1. Disconnect white wire from the oil pressure switch on the engine.
2. Ground white wire to the engine block.
3. Turn ignition switch to ON; the oil pressure light should come on indicating correct operation of the electrical wiring to the oil pressure switch.
4. Turn ignition switch to OFF. Reconnect white wire to the oil pressure switch.



Figure 10

1. Low oil pressure light

## Cruise Control Switch

The cruise control switch is positioned on the dash panel above the ignition switch (Fig. 11). This switch energizes the cruise control coil to allow the operator to maintain a constant ground speed.

### Testing

1. Make sure ignition switch is off. Locate switch and unplug machine wire harness connector from switch.
2. The switch terminals are marked as shown in Figure 12. In the ON position, continuity should exist between terminals 2 and 3. In the momentary SET position, continuity should exist between terminals 5 and 6. In the OFF position, there should be no continuity between any switch terminals.
3. Terminals 7 (-) and 8 (+) are used for the indicator light in the switch. The light should be illuminated when the switch is in the ON position.
4. Reconnect the harness connector to the switch after testing.



Figure 11

1. Cruise control switch

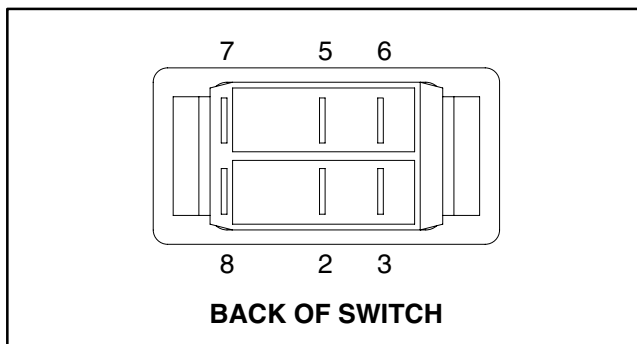

Figure 12

## Cruise Control Coil

The cruise control coil is energized by the cruise control switch. The energized coil becomes a magnet to hold the traction pedal in position and maintains ground speed for accurate sprayer operation.

### Testing

1. Make sure ignition switch is off. Locate control coil next to traction pedal under the floorboard (Fig. 13). Unplug coil connector from machine wire harness.

**NOTE:** Prior to taking small resistance readings with a digital multi meter, short the meter test leads together. The meter will display a small resistance value (usually 0.5 ohms or less). This resistance is due to the internal resistance of the meter and test leads. Subtract this value from the measured value of the coil you are testing.

2. Using a multimeter (ohms setting), verify control coil resistance between the terminals of the connector and the frame of the coil. Resistance should be from 3.6 to 4.0 ohms.
3. If coil does not engage when voltage is applied or coil resistance is incorrect, replace control coil.
4. Reconnect the coil connector to the machine harness after testing.

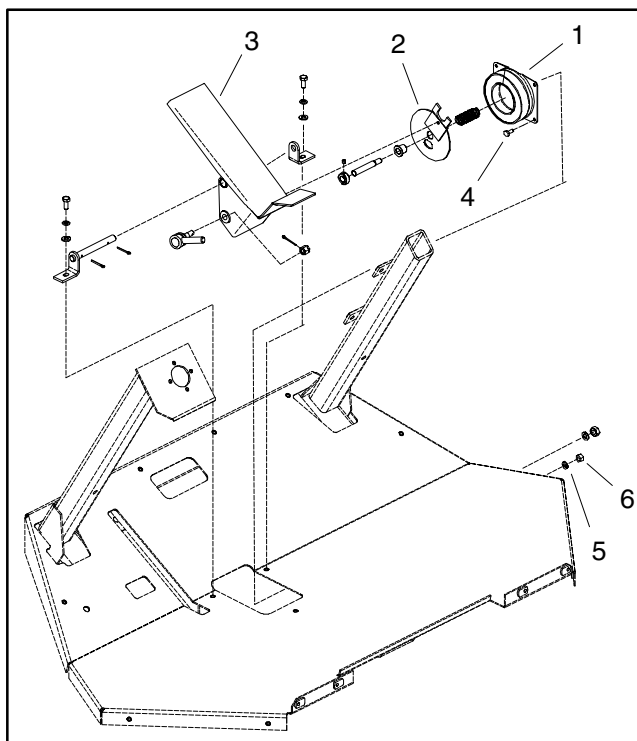

Figure 13

- |                        |                         |
|------------------------|-------------------------|
| 1. Cruise control coil | 4. Cap screw (4 used)   |
| 2. Plate               | 5. Lock washer (4 used) |
| 3. Traction pedal      | 6. Hex nut (4 used)     |



## Brake Pedal Switch

The brake pedal switch is mounted on the frame under the floorboard (Fig. 14). The brake pedal switch prevents the cruise control coil from being energized when the brake pedal is pushed.

### Testing

1. Make sure ignition switch is off. Locate switch and unplug wire harness connector from switch.
2. When the switch plunger is pressed (brake pedal released), there should be continuity between the switch terminals. When the switch plunger is extended (brake pedal depressed), there should be no continuity between the switch terminals.
3. Reconnect the harness connector to the switch after testing.

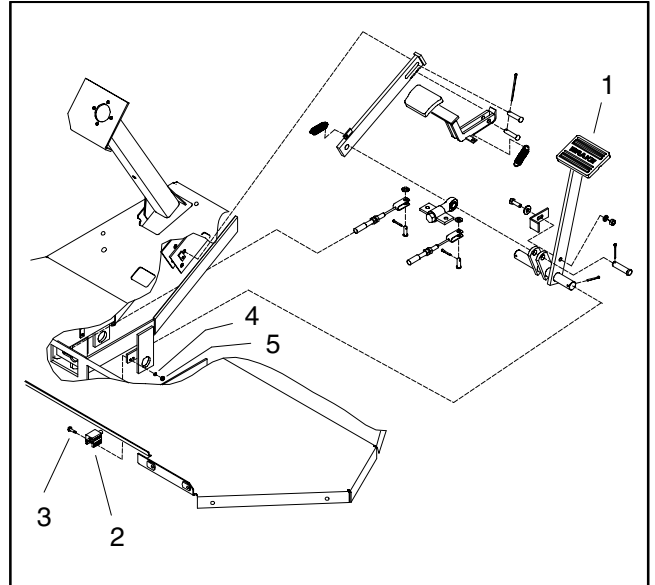

Figure 14

- |                       |                |
|-----------------------|----------------|
| 1. Brake pedal        | 4. Lock washer |
| 2. Brake pedal switch | 5. Hex nut     |
| 3. Washer head screw  |                |

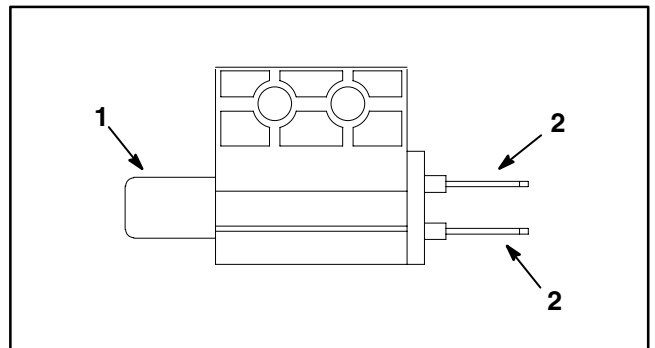

Figure 15

- |                   |                    |
|-------------------|--------------------|
| 1. Switch plunger | 2. Switch terminal |
|-------------------|--------------------|

## Temperature Sender

The temperature sender is located near the alternator on the water flange attached to the engine cylinder head (Fig. 16). There is a red/white wire attached to the terminal of the switch.

### Testing

1. Lower coolant level in the engine and remove the temperature sender from water flange.
2. Put switch in a container of oil with a thermometer and slowly heat the oil (Fig. 17).



## CAUTION

Handle the hot oil with extreme care to prevent personal injury or fire.

**NOTE:** Prior to taking resistance readings with a digital multimeter, short the meter test leads together. The meter will display a small resistance value (usually 0.5 ohms or less). This resistance is due to the internal resistance of the meter and test leads. Subtract this value from the measured value of the temperature sender you are testing.

3. Check resistance of the sender with a multimeter (ohms setting) as the temperature increases.

A. The meter should indicate more than 600 ohms at 70°F (21°C).

B. The meter should indicate approximately 460 ohms at 100°F (38°C).

C. The meter should indicate from 54 to 78 ohms at 200°F (93°C).

D. Replace sender if specifications are not met.

4. Install sender to the water flange.

A. Clean threads of water flange and sender thoroughly. Apply thread sealant to the threads of the sender.

B. Screw sender into the water flange. Torque sender from 16 to 20 ft-lb (21.7 to 27.1 N-m).

C. Reconnect red/white wire to sender.

5. Fill engine cooling system (see Operator's Manual).

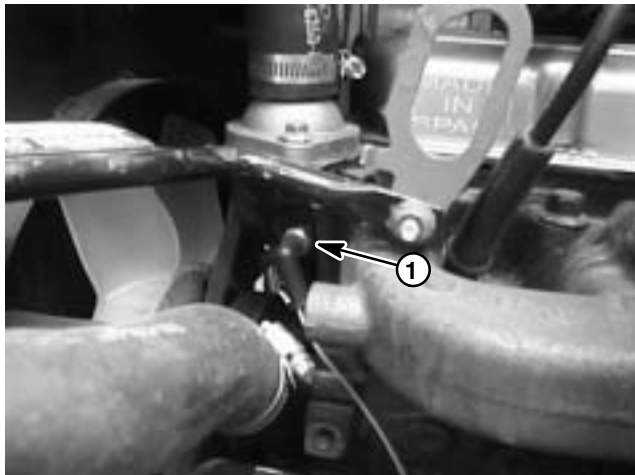

Figure 16

1. Temperature sender

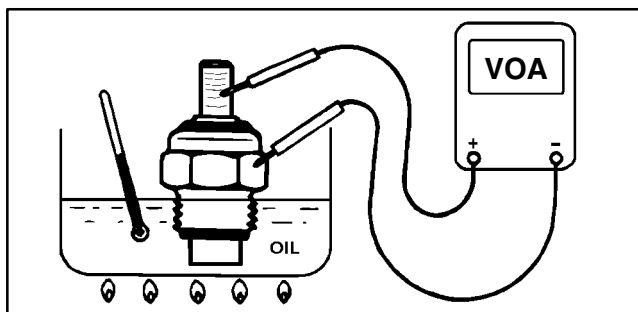
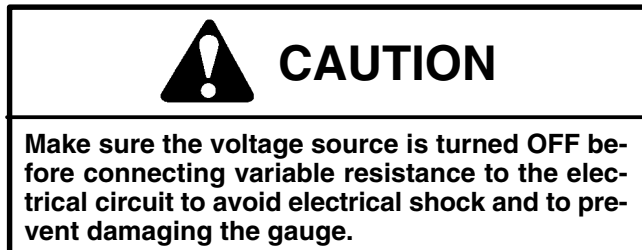

Figure 17

## Temperature Gauge

The temperature gauge can be tested using a new gauge as a substitute or by using a DC voltage source and a variable resistance box.

### Testing



1. Make sure ignition switch is off. Connect temperature gauge to the variable resistance and DC voltage source (Fig. 18).

2. Take test point readings (Fig. 19).

**IMPORTANT: Allow circuit to warm up for at least 5 minutes before taking test readings.**

A. Set variable resistance to 54 ohms. Apply a  $14 \pm 0.01$  VDC to the circuit. The needle should point to the middle of the green area.

B. Set variable resistance to 31 ohms. The needle should point to the beginning of the red area.

3. Turn off the voltage source. Disconnect voltage source and variable resistance from gauge.

4. Connect wire harness to temperature gauge:

Harness black wire to G terminal.  
Harness green/red wire to I terminal.  
Harness red/white wire to S terminal.

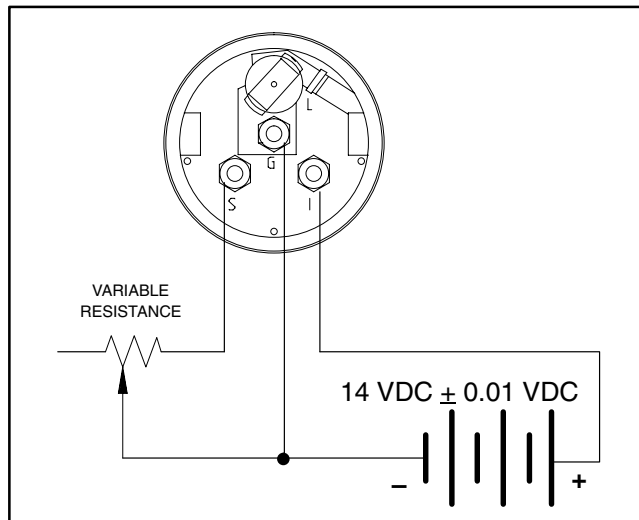

Figure 18

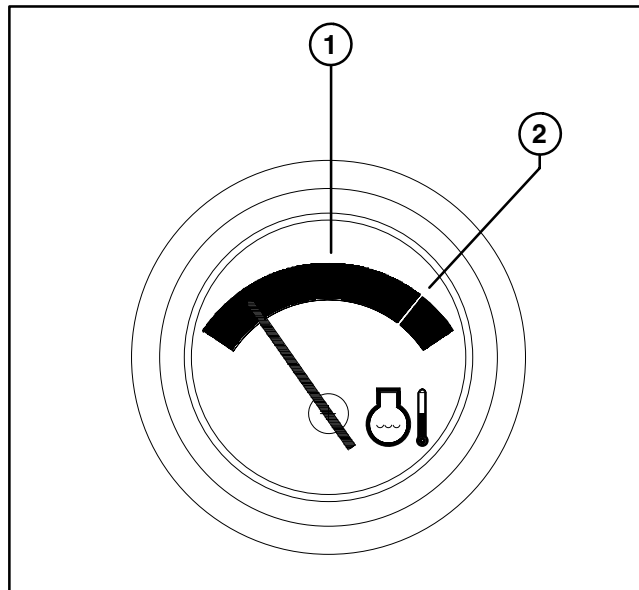

Figure 19

1. Middle position

2. Start of red area

## Traction Speed Sensor

The traction speed sensor is attached to the right side rear wheel motor (Fig. 21). The sensor provides ground speed information for the optional Pro Control Spray System. It uses a magnetically based, Hall Effect integrated circuit. As the piston group in the wheel motor turns, the sensor accurately senses the movement of the pistons passing the sensor. The red connector wire (connector terminal A) is the positive lead, the black wire (terminal C) is the ground lead, and the white wire (terminal B) is the signal output.

### Testing

1. Make sure ignition switch is off. Remove speed sensor from machine (see Traction Speed Sensor Removal in the Service and Repair Section of this Chapter).

**IMPORTANT: Incorrect jumper wire connections during testing can damage the sensor.**

2. Using a +12 VDC battery, a multimeter, a 1K ohm resistor and appropriate jumper wires, connect the battery and multimeter to the speed sensor using Figure 22 as a guide.

3. Set multimeter to DC volts setting.

4. The multimeter should display very low voltage when a metal object is held near the sensor tip. The multimeter should display battery voltage when the metal object is moved away from the sensor tip.

5. After sensor testing is complete, remove jumper wires, resistor and multimeter leads from sensor connector.

**IMPORTANT: When replacing the sensor, see Traction Speed Sensor Installation in the Service and Repair Section of this chapter.**

6. Reinstall speed sensor into wheel motor (see Traction Speed Sensor Installation in the Service and Repair Section of this Chapter). Reconnect speed sensor to machine wire harness.

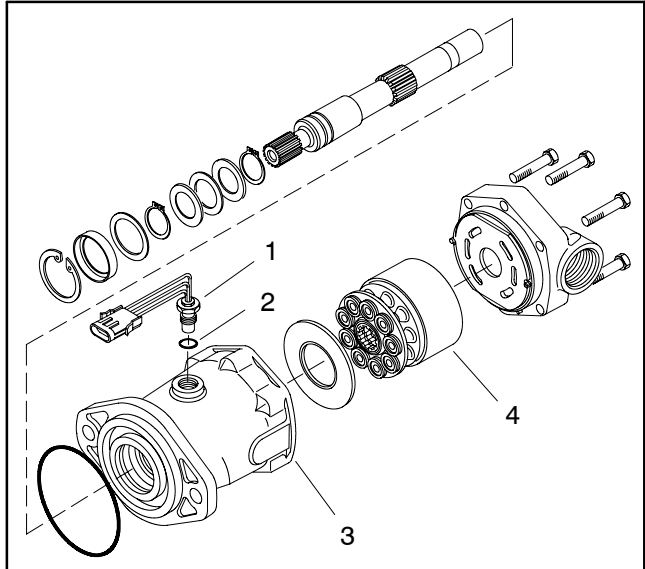

Figure 21

- |                 |                           |
|-----------------|---------------------------|
| 1. Speed sensor | 3. RH wheel motor housing |
| 2. O-ring       | 4. Motor piston group     |

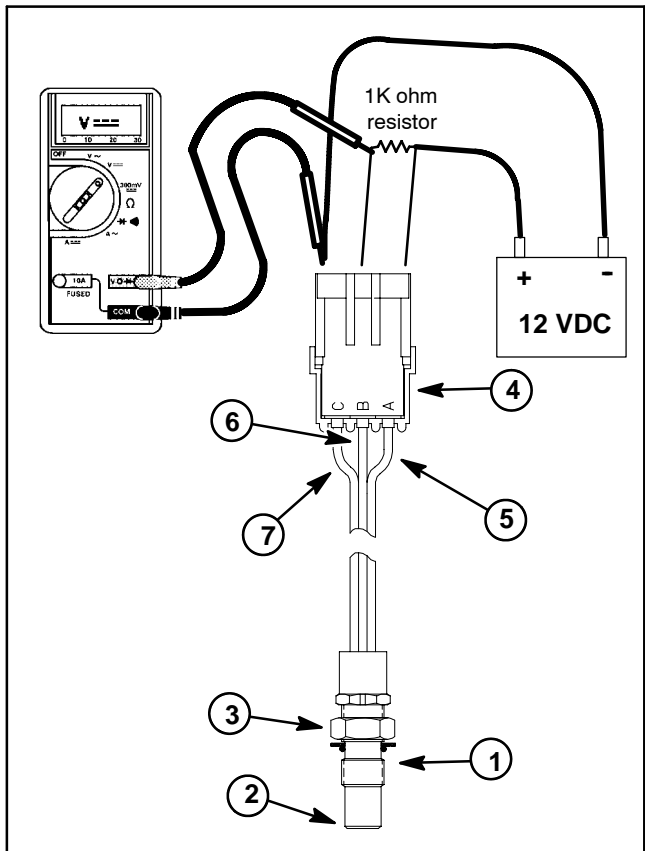

Figure 22

- |                     |               |
|---------------------|---------------|
| 1. Speed sensor     | 5. Red wire   |
| 2. Sensor tip       | 6. White wire |
| 3. Lock nut         | 7. Black wire |
| 4. Sensor connector |               |

## Accessory Solenoid

The accessory solenoid provides a current supply to the spray system and optional accessories (e.g. electric boom lifts and foam markers). The solenoid is energized when the ignition key switch is in the RUN position. The accessory solenoid is located under the operator seat (Fig.22).

### Testing

1. Make sure engine is off. Disconnect battery cables from battery making sure to disconnect negative (-) cable first and then positive (+) cable.

2. Raise operator seat and locate accessory solenoid. Put labels on wires for proper installation after repairs are completed. Disconnect machine harness wires from solenoid.

3. Apply 12 VDC (+) to the solenoid coil post and ground the solenoid mount with a jumper wire. The solenoid should click. Using a multimeter (ohms setting), make sure resistance across the main contact posts is less than 1 ohm.

4. Remove voltage from solenoid coil post. The solenoid should click. Make sure resistance across the main contact posts is infinite ohms (no continuity).

5. Replace accessory solenoid if necessary.

6. Reconnect electrical connections to solenoid: red cable to engine starter on one main contact post, red wire to fuse block on the other main contact post, and green/red wire on coil post.

7. Reconnect battery cables to battery making sure to install positive (+) cable first and then negative (-) cable.

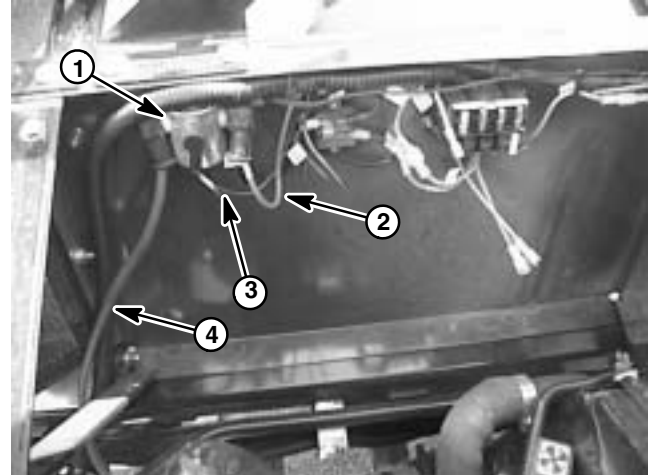

Figure 22

- |                         |                           |
|-------------------------|---------------------------|
| 1. Accessory solenoid   | 3. Red wire to fuse block |
| 2. Red cable to starter | 4. Green/red wire         |

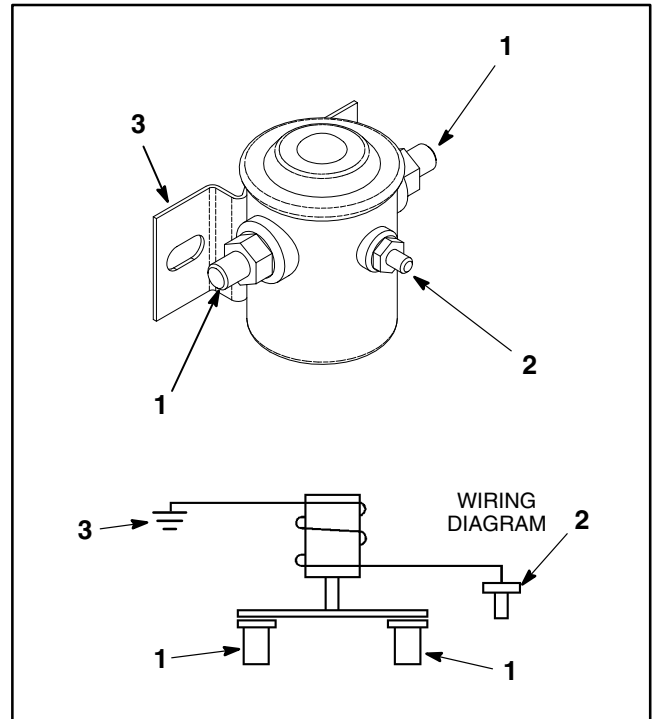

Figure 23

- |                       |                   |
|-----------------------|-------------------|
| 1. Main contact post  | 3. Solenoid mount |
| 2. Solenoid coil post |                   |

## Pressure Rate and Boom Actuator (Optional) Switches

The pressure rate (increase/decrease) switch is located on the spray control console (Fig. 24). This switch along with the Manual Interface Module (or Pro Control, if equipped) changes the applied current to the PWM valve which controls hydraulic flow to the hydraulic motor that drives the spray pump. Pressing the switch to the increase position allows additional current to the PWM valve which increases flow to the hydraulic motor. The spray pump increases speed to allow additional flow and pressure from the spray pump. Moving the switch to the decrease position reduces current to the PWM valve and results in less flow and pressure from the spray pump.

On machines equipped with the optional electric boom lift kit, this switch is used to operate the boom actuators to raise or lower the booms.

### Testing

1. Make sure ignition switch is off. Locate switch, remove console panel, and unplug wire harness connector from switch.

2. The switch terminals are marked as shown in Figure 25. In the INCREASE or boom raise position, continuity should exist between terminals 2 and 3 and also between terminals 5 and 6. In the neutral, center position, there should be no continuity between any switch terminals. In the DECREASE or boom lower position, continuity should exist between terminals 2 and 1 and also between terminals 5 and 4.

3. Reconnect the harness connector to the switch after testing.

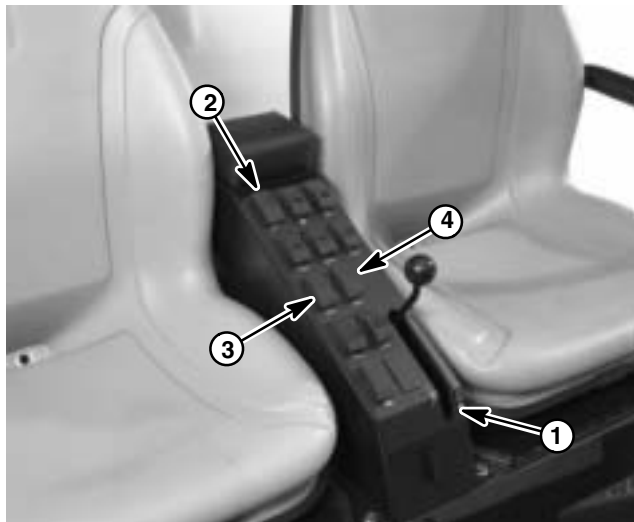

Figure 24

- 1. Spray control console
- 2. Pressure +/- switch
- 3. RH boom switch (opt.)
- 4. LH boom switch (opt.)

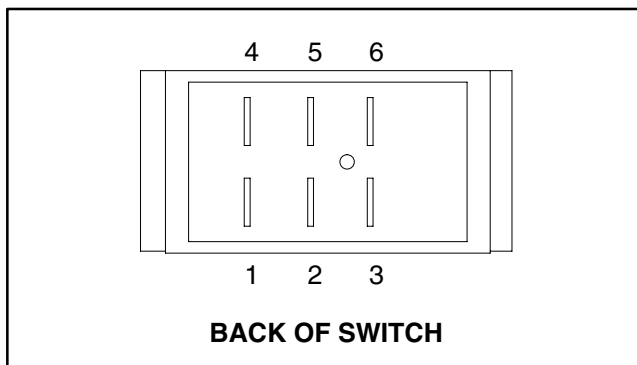

Figure 25

## Spray Pump, Agitation and Boom Control Switches

The spray pump (on/off), agitation (on/off) and boom (on/off) control switches are located on the spray control console (Fig. 26).

### Testing

1. Make sure ignition switch is off. Remove console panel, locate switch and unplug machine wire harness connector from switch.

2. The switch terminals are marked as shown in Figure 27. In the ON position, continuity should exist between terminals 2 and 3 and also between terminals 5 and 6. In the OFF position, continuity should exist between terminals 1 and 2 and also between terminals 4 and 5.

3. Terminals 7 (–) and 8 (+) are used for the indicator light in the switch. The light should be illuminated when the switch is in the ON position.

4. Reconnect the harness connector to the switch after testing.

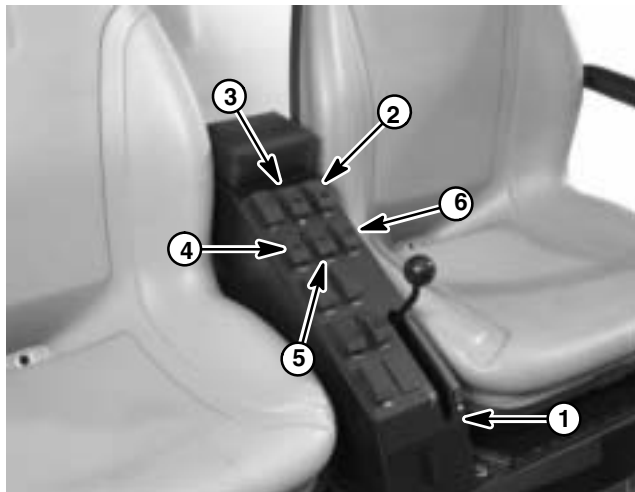

Figure 26

- |                          |                       |
|--------------------------|-----------------------|
| 1. Spray control console | 4. RH boom switch     |
| 2. Agitation switch      | 5. Center boom switch |
| 3. Spray pump switch     | 6. LH boom switch     |

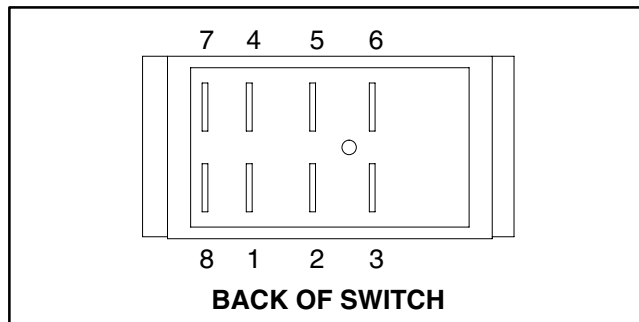

Figure 27

## Master Boom (Foot) Switch

The master boom switch is located on the floorboard of the machine (Fig. 28). This switch allows the machine operator to control the operation of all boom sections using one switch.

### Testing

1. Make sure ignition switch is off. Locate switch and unplug machine wire harness connector from switch.
2. The switch, switch harness, and connector are shown in Figure 29. Depress the switch until continuity exists between connector terminals A and C. At that switch position, continuity should also exist between terminals B and D.
3. Depress the switch and continuity should now exist between terminals A and D and also between terminals B and C.
4. Regardless of switch position, there should never be continuity between connector terminals A and B or terminals C and D.
5. Reconnect the switch connector to the machine harness after testing.



Figure 28

1. Master boom switch

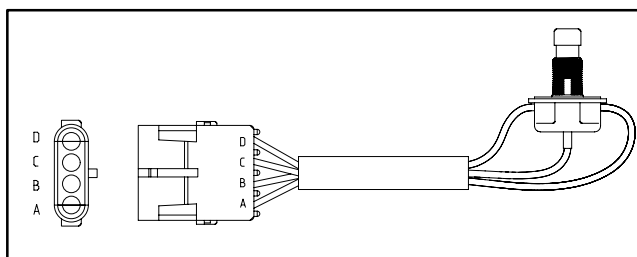

Figure 29



## Pulse Width Modulated (PWM) Valve Solenoid

The Pulse Width Modulated (PWM) Valve which controls hydraulic flow to the spray pump motor includes an electric solenoid (Fig. 30). When the spray console rate switch is depressed, the available current to the PWM valve solenoid is changed. This solenoid current change causes a valve shift and subsequent change in hydraulic flow to the spray pump motor. Testing of the PWM Valve solenoid can be done without removing the solenoid.

### Testing

**NOTE:** Prior to taking small resistance readings with a digital multimeter, short the meter test leads together. The meter will display a small resistance value (usually 0.5 ohms or less). This resistance is due to the internal resistance of the meter and test leads. Subtract this value from the measured value of the solenoid you are testing.

1. Make sure ignition switch is off. Disconnect PWM Valve solenoid electrical connector.
2. Measure resistance between the two solenoid connector terminals. The resistance for the solenoid coil should be approximately 9.6 ohms.

**NOTE:** The solenoid is not available as a separate component.

3. Reconnect electrical connector to the solenoid.

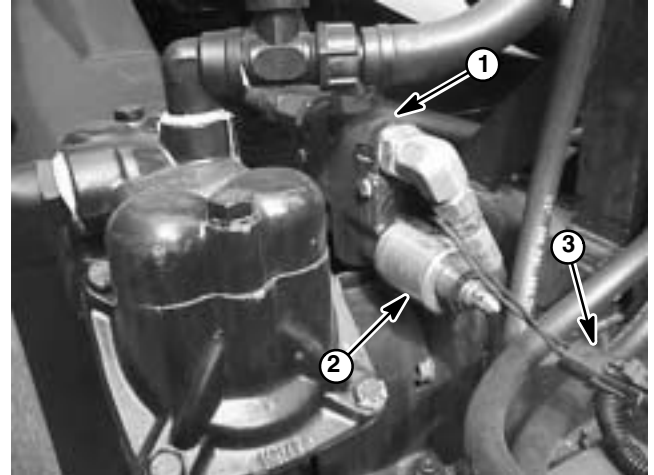

Figure 30

1. PWM Valve  
2. Solenoid

3. Solenoid connector

## Manual Interface Module

The manual interface module is used in conjunction with the increase/decrease switch to adjust current flow to the PWM Valve and to maintain pump rate settings when the booms are turned off and on again using the master boom (foot) switch. The module is fastened to the head light shield under the dash panel (Fig. 31). The manual interface module is disabled if a Pro Control is installed in the spray system.

Once the operator has set the spray application rate, whenever the master boom switch is turned off, the module stores the current (mA) setting available to the PWM valve solenoid. When the master boom switch is used to begin spraying again, the module ensures that the spray application rate is unchanged. Because of the module, the operator does not have to reset spray rates when the master boom switch is used to turn the spray booms back on.

The interface module is a solid state device and there is no reliable means of bench testing the module. If spray rates have to be reset after turning the booms off and on with the master boom switch, the manual interface module should be suspect.

Testing of the interface module, circuit wiring and increase/decrease switch can be performed as follows:

1. Make sure ignition switch is off. Disconnect PWM Valve solenoid electrical connector from the machine wiring harness.

2. Connect one multimeter test lead to one of the harness connector leads and the other meter test lead to the second harness connector lead (Fig. 32). Set multimeter to DC Volts setting.

3. Turn ignition switch to the RUN position.

4. While monitoring the multimeter display, use the increase/decrease switch to adjust spray rate:

- A. Pressing the increase/decrease switch to increase should result in an increased voltage displayed on the multimeter.

- B. Pressing the increase/decrease switch to decrease should result in a decreased voltage displayed on the multimeter.

5. If voltage change to the PWM Valve is correct, the interface module, circuit wiring and increase/decrease switch are functioning correctly. If voltage change is incorrect, test increase/decrease switch and then circuit wiring. Replace manual interface module only after other components have tested acceptably.

6. Remove multimeter and reconnect PWM Valve electrical connector to the machine harness.

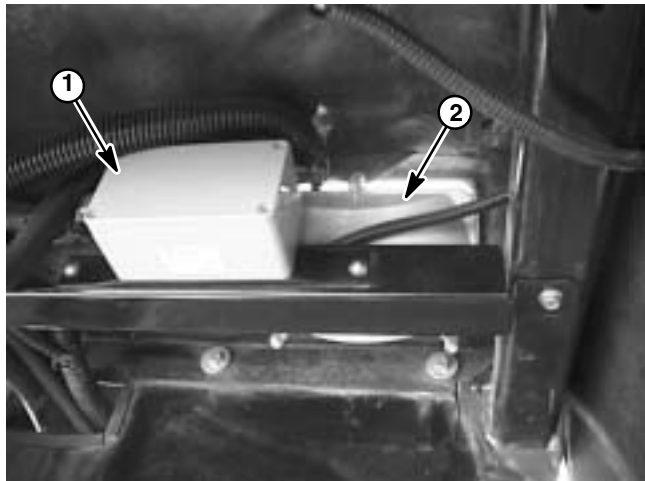

Figure 31

1. Manual interface module    2. RH headlight

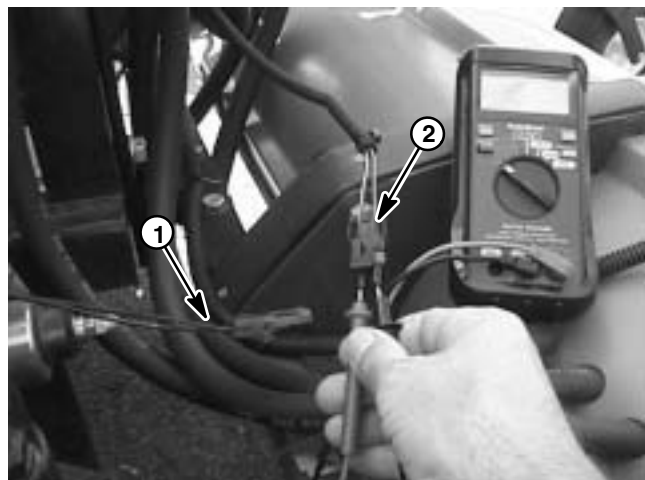

Figure 32

1. PWM Valve connector    2. Harness connector

## Cruise Relay (Serial Numbers 230000400 and Above)

The cruise relay is used to energize the cruise control coil and is located under the operator seat.

### Testing

**NOTE:** Prior to taking small resistance readings with a digital multimeter, short the meter test leads together. The meter will display a small resistance value (usually 0.5 ohms or less). This resistance is due to the internal resistance of the meter and test leads. Subtract this value from the measured value of the component you are testing.

1. Verify coil resistance between terminals 85 and 86 with a multimeter (ohms setting). Resistance should be from 70 to 95 ohms.
2. Connect multimeter (ohms setting) leads to relay terminals 30 and 87. Ground terminal 86 and apply +12 VDC to terminal 85. The relay should make and break continuity between terminals 30 and 87 as +12 VDC is applied and removed from terminal 85.
3. Disconnect voltage from terminal 85 and multimeter lead from terminal 87.
4. Connect multimeter (ohms setting) leads to relay terminals 30 and 87A. Apply +12 VDC to terminal 85. The relay should make and break continuity between terminals 30 and 87A as +12 VDC is applied and removed from terminal 85.
5. Disconnect voltage and multimeter leads from the relay terminals.

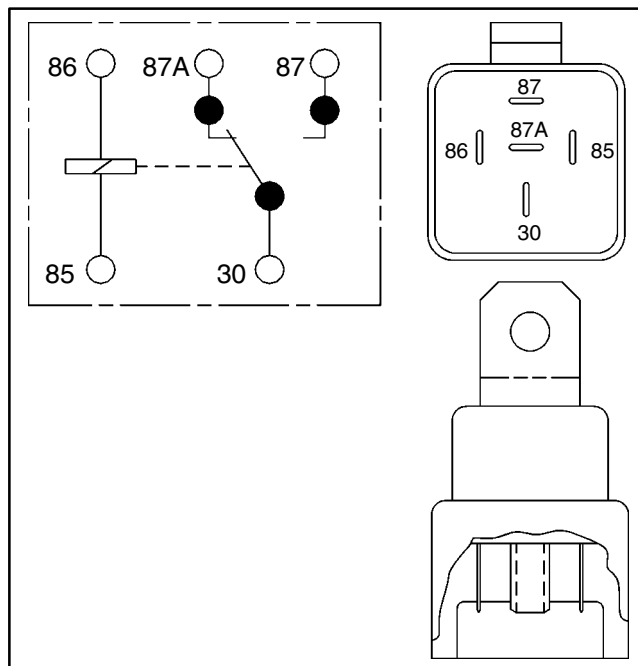

Figure 33

## Diode Assembly (Serial Numbers 230000400 and Above)

Two diode assemblies (Fig. 34) are used in the Multi Pro 5600 wiring harness. Diode D1 is used to provide a latching circuit for the cruise relay. Diode D2 is used for circuit protection from voltage spikes that occur when the cruise control coil is de-energized.

These diodes plug into the vehicle wire harness (see wire harness drawings in Chapter 8 – Electrical Diagrams).

### Testing

The diodes can be individually tested using a digital multimeter (diode test or ohms setting) and the table to the right.

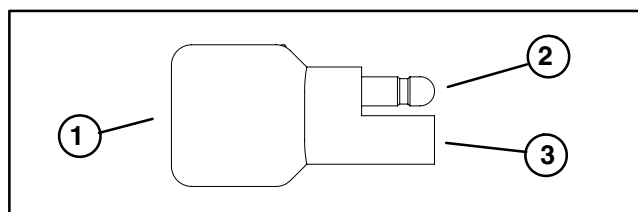

Figure 34

1. Diode assembly
2. Male terminal
3. Female terminal

Multimeter Red Lead (+) on Terminal	Multimeter Black Lead (-) on Terminal	Continuity
Female	Male	YES
Male	Female	NO

# Service and Repairs

**NOTE:** See the Ford VSG – 411/413 Engine Service Manual for engine electrical component repair information.

## Headlights

### Removal and Installation

1. Set parking brake, turn ignition off, and remove key.
2. Remove two (2) flange head screws that secure shield to machine. Position shield away from back of headlight.
3. Unplug wiring harness connector from headlight bulb.

**NOTE:** Headlight bulb can be replaced without removing headlight body. Be careful when servicing bulb. Never touch bulb with fingers – handle bulb by the base.

4. To replace the headlight bulb:
  - A. Turn the bulb approximately 1/4 turn counter-clockwise and remove bulb from headlight body.
  - B. Align bulb base with hole in headlight body. Insert bulb into headlight body and turn the bulb approximately 1/4 turn clockwise.
5. If headlight body or lens requires removal, remove three (3) screws that secure headlight assembly to machine. Remove headlight assembly. Install in reverse order.
6. After repairs are completed, attach wiring harness connector to headlight bulb.
7. Attach shield to machine with two (2) flange head screws.

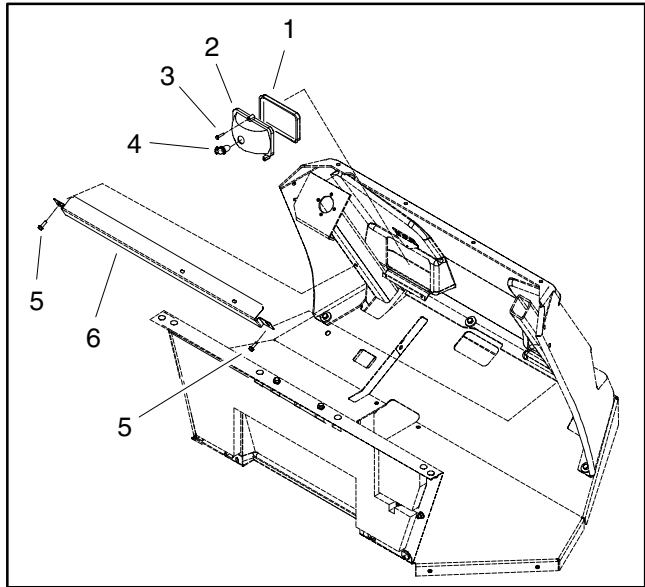

Figure 35

- |                   |                      |
|-------------------|----------------------|
| 1. Headlight lens | 4. Headlight bulb    |
| 2. Headlight body | 5. Flange head screw |
| 3. Screw (3 used) | 6. Shield            |

## Traction Speed Sensor

### Removal (Fig. 37)

1. Locate speed sensor on right side wheel motor. Disconnect speed sensor from machine wire harness.
2. Loosen lock nut and remove speed sensor from wheel motor.

### Installation (Fig. 37)

1. Thread lock nut fully onto speed sensor threads.
2. Center a wheel motor piston in the center of the sensor port (see Sensor Port View in Fig. 38). Use a suitable tool to feel when a motor piston is in the center of the sensor port.
3. Lubricate O-ring and install onto sensor threads.
4. Thread sensor into port until sensor contacts piston. Rotate motor output shaft one complete revolution to make sure it rotates freely.
5. Turn sensor out (counter-clockwise) until sensor orientation grooves are at a right angle  $+ 3^\circ$  to motor centerline, then back out sensor one full turn. Hold sensor at this position and torque lock nut from 75 to 125 in-lb (8.5 to 14.1 N-m).
6. Plug speed sensor connector into machine wire harness.

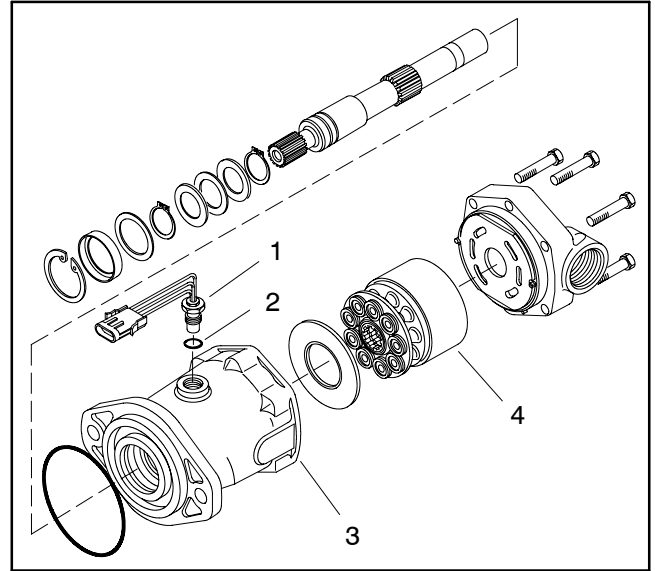

Figure 37

- |                 |                           |
|-----------------|---------------------------|
| 1. Speed sensor | 3. RH wheel motor housing |
| 2. O-ring       | 4. Motor piston group     |

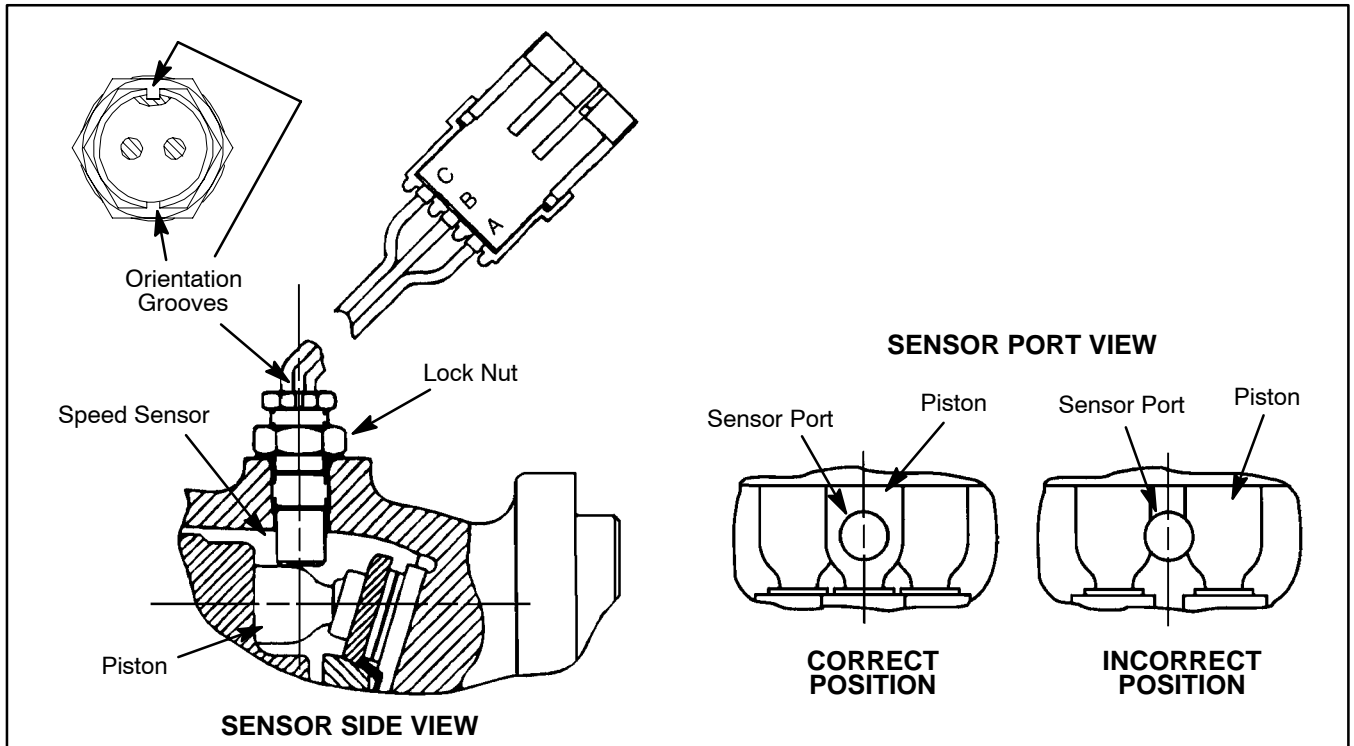

Figure 38

## Cruise Control Coil

### Removal (Fig. 39)

1. Set parking brake, turn ignition off, and remove key.
2. Remove hex nut and lock washer that secure shaft to machine frame. Remove shaft with collar, flange bushing, plate, and compression spring.
3. Unplug cruise control coil connector from machine wiring harness. Remove four (4) cap screws, lock washers, and hex nuts that secure coil to frame. Remove cruise control coil.

### Installation (Fig. 39)

1. Attach cruise control coil to frame using four (4) cap screws, lock washers, and hex nuts.
2. Position compression spring, plate, and flange bushing to machine making sure to align plate slot with post on traction pedal. Apply anti-seize lubricant to shaft and insert shaft with collar. Secure shaft to frame with hex nut and lock washer.
3. Plug cruise control coil connector into machine wiring harness.
4. Check that gap between cruise coil and plate is approximately 3/32" (2.4 mm). If gap is incorrect, loosen set screw in collar and slide collar on shaft to allow proper gap. Tighten set screw to secure collar on shaft.

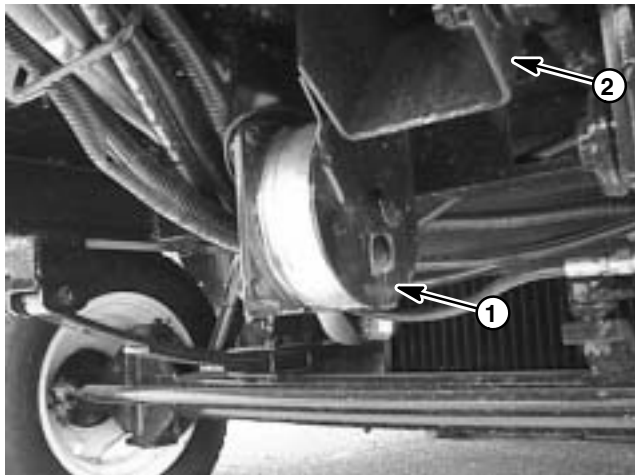

Figure 38

1. Cruise control coil      2. Traction pedal

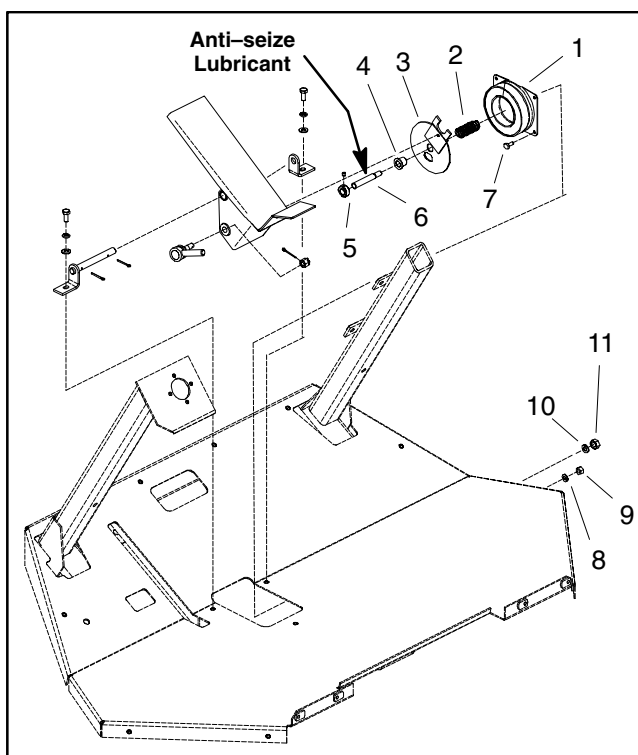

Figure 39

- |                        |                         |
|------------------------|-------------------------|
| 1. Cruise control coil | 7. Cap screw (4 used)   |
| 2. Compression spring  | 8. Lock washer (4 used) |
| 3. Plate               | 9. Hex nut (4 used)     |
| 4. Flange bushing      | 10. Shaft lock washer   |
| 5. Collar w/setscrew   | 11. Shaft hex nut       |
| 6. Shaft               |                         |

---

## Battery Storage

If the machine will be stored for more than 30 days:

1. Remove the battery and charge it fully (see Battery Service).
2. Either store battery on a shelf or on the machine.
3. Leave cables disconnected if the battery is stored on the machine.

4. Store battery in a cool atmosphere to avoid quick deterioration of the battery charge.

5. To help prevent the battery from freezing, make sure it is fully charged (see Battery Service).

---

## Battery Care

1. Battery electrolyte level must be properly maintained. The top of the battery must be kept clean. If the machine is stored in a location where temperatures are extremely high, the battery will run down more rapidly than if the machine is stored in a location where temperatures are cool.

 <b>WARNING</b>
<p><b>Wear safety goggles and rubber gloves when working with electrolyte. Charge battery in a well ventilated place so gasses produced while charging can dissipate. Since the gases are explosive, keep open flames and electrical sparks away from the battery; do not smoke. Nausea may result if the gases are inhaled. Unplug charger from electrical outlet before connecting or disconnecting charger leads to or from battery posts.</b></p>

**IMPORTANT: Do not remove battery fill caps while cleaning.**

2. Check battery condition weekly or after every 50 hours of operation. Keep terminals and entire battery case clean because a dirty battery will discharge slowly.

A. Clean battery by washing entire case with a solution of baking soda and water. Rinse with clear water.

B. Coat battery posts and cable connectors with skin-over grease (Toro Part No. 505-47) or petroleum jelly to prevent corrosion.

3. Battery cables must be tight on terminals to provide good electrical contact.

 <b>WARNING</b>
<p><b>Connecting cables to the wrong post could result in personal injury and/or damage to the electrical system.</b></p>

4. If corrosion occurs at terminals, disconnect cables. Always disconnect negative (-) cable first. Clean clamps and terminals separately. Reconnect cables with positive (+) cable first. Coat battery posts and cable connectors with skin-over grease (Toro Part No. 505-47) or petroleum jelly to prevent corrosion.

5. Check electrolyte level every 25 operating hours, and every 30 days if machine is in storage.

6. Maintain cell level with distilled or demineralized water. Do not fill cells above the fill line.

## Battery Service

The battery is the heart of the electrical system. With regular and proper service, battery life can be extended. Additionally, battery and electrical component failure can be prevented.



### CAUTION

**When working with batteries, use extreme caution to avoid splashing or spilling electrolyte. Electrolyte can destroy clothing and burn skin or eyes. Always wear safety goggles and a face shield when working with batteries.**

#### Electrolyte Specific Gravity

Fully charged: 1.265 corrected to 80°F (26.7°C)  
Discharged: less than 1.240

#### Battery Specifications

BCI Group Size 24  
420 CCA at 0° F (-18° C)  
Reserve Capacity of 67 minutes at 80°F (27°C)

#### Dimensions (including terminal posts)

Length 10.2 inches (25.9 cm)  
Width 6.8 inches (17.3 cm)  
Height 9 inches (22.9 cm)

### Battery Removal (Fig. 40)

**IMPORTANT: Be careful not to damage battery terminal posts or cable connectors when removing the battery cables.**

1. Make sure ignition and all accessories are **OFF**.
2. Using two wrenches, loosen cap screw and nut on ground (-) cable connector first and then remove ground (-) cable from battery. This should prevent short circuiting the battery, other components, or the operators' hands.
3. Loosen cap screw and nut on positive (+) cable connector using two wrenches. Remove positive (+) cable from battery.
4. Loosen cap screw and flange nut that secure battery retainer to the battery compartment.
5. Make sure battery vent caps are on tightly.
6. Remove battery from the battery compartment to a service area to allow better access for service.

### Battery Installation (Fig. 40)

**IMPORTANT: To prevent possible electrical problems, install only a fully charged battery.**

1. Make sure ignition and all accessories are **OFF**.

2. Make sure battery compartment is clean and repainted if necessary. Make sure all battery cables, connections and battery retainer are in good condition.

3. Place battery in its compartment with the battery posts toward the front of the vehicle. Make sure battery is level and flat.

4. Secure battery retainer. Do not overtighten to prevent cracking or distorting the battery case.

5. Connect positive (+) cable connector onto positive battery post. Tighten cap screw and nut using two wrenches.

6. Connect a digital multimeter (set to amps) between the negative battery post and the ground (-) cable connector. The reading should be less than 0.1 amp. If the reading is 0.1 amp or more, the unit's electrical system should be tested and repaired.

7. Connect ground (-) cable connector to the negative battery post. Tighten cap screw and lock nut using two wrenches.

8. Coat battery posts and cable connectors with skin-over grease (Toro Part No. 505-47) or petroleum jelly to prevent corrosion.

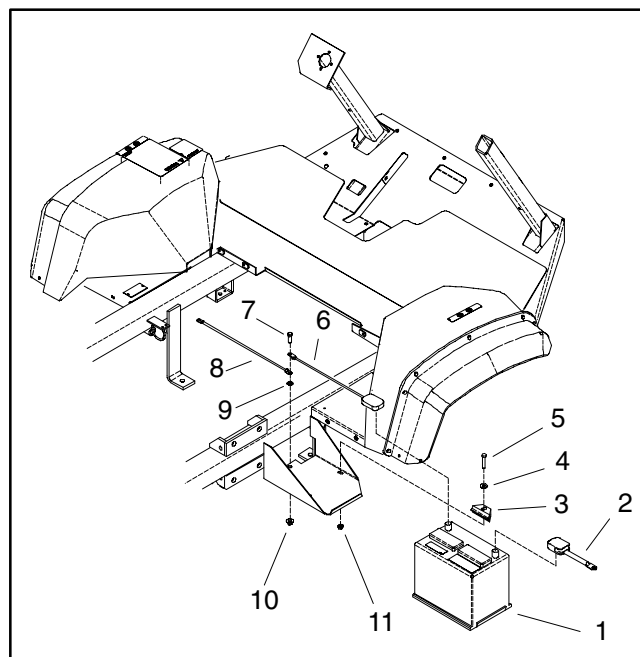

Figure 40

- |                           |                 |
|---------------------------|-----------------|
| 1. Battery                | 7. Cap screw    |
| 2. Positive battery cable | 8. Ground cable |
| 3. Battery retainer       | 9. Lock washer  |
| 4. Flat washer            | 10. Flange nut  |
| 5. Cap screw              | 11. Flange nut  |
| 6. Negative battery cable |                 |



## Inspection, Maintenance, and Testing

1. Perform the following inspections and maintenance:

- A. Replace battery if cracked or leaking.
- B. Check battery terminal posts for corrosion. Use wire brush to clean corrosion from posts.

**IMPORTANT: Before cleaning the battery, tape or block vent holes to the filler caps and make sure the caps are on tightly.**

C. Check for signs of wetness or leakage on the top of the battery which might indicate a loose or missing filler cap, overcharging, loose terminal post, or overfilling. Also, check battery case for dirt and oil. Clean the battery with a solution of baking soda and water, then rinse it with clean water.

D. Check that the cover seal is not broken away. Replace the battery if the seal is broken or leaking.

E. Check the electrolyte level in each cell. If the level is below the tops of the plates in any cell, fill all cells with **distilled water** between the minimum and maximum fill lines. Charge at 15 to 25 amps for 15 minutes to allow sufficient mixing of the electrolyte.

2. Conduct a hydrometer test of the battery electrolyte.

**IMPORTANT: Make sure the area around the cells is clean before opening the battery caps.**

A. Measure the specific gravity of each cell with a hydrometer. Draw electrolyte in and out of the hydrometer barrel prior to taking a reading to warm-up the hydrometer. At the same time take the temperature of the cell.

B. Temperature correct each cell reading. For each 10°F (5.5°C) above 80°F (26.7°C) add 0.004 to the specific gravity reading. For each 10°F (5.5°C) below 80°F (26.7°C) subtract 0.004 from the specific gravity reading.

Example: Cell Temperature	100°F
Cell Gravity	1.245
100°F minus 80°F equals 20°F	
(37.7°C minus 26.7°C equals 11.0°C)	
20°F multiply by 0.004/10°F equals 0.008	
(11°C multiply by 0.004/5.5°C equals 0.008)	
ADD (conversion above)	<u>0.008</u>
Correction to 80°F (26.7°C)	1.253

C. If the difference between the highest and lowest cell specific gravity is 0.050 or greater or the lowest cell specific gravity is less than 1.225, charge the battery. Charge at the recommended rate and time given in **Charging** or until all cells specific gravity is 1.225 or greater with the difference in specific gravity between the highest and lowest cell less than 0.050. If these charging conditions can not be met, replace the battery.

3. Perform a high-discharge test with an adjustable load tester.

This is one of the most reliable means of testing a battery as it simulates the cold-cranking test. A commercial battery load tester is **required** to perform this test.



A. Check the voltage across the battery terminals prior to testing the battery. If the voltage is less than 12.4 VDC, recharge the battery.

B. If the battery has been charged, apply a 150 amp load for 15 seconds to remove the surface charge. Use a battery load tester following the manufacturer's instructions.

C. Make sure battery terminals are free of corrosion.

D. Measure the temperature of the center cell.

E. Connect a battery load tester to the battery terminals **following the battery tester manufacturer's instructions**. Connect a digital multimeter to the battery terminals.

F. Apply a test load of one half the Cranking Performance (see Battery Specifications) rating of the battery for 15 seconds.

G. Take a voltage reading at 15 seconds, then remove the load.

H. Using the table below, determine the minimum voltage for the cell temperature reading:

Minimum Voltage	Battery Electrolyte Temperature	
	70°F (and up)	21.1°C (and up)
9.6	70°F (and up)	21.1°C (and up)
9.5	60°F	15.6°C
9.4	50°F	10.0°C
9.3	40°F	4.4°C
9.1	30°F	-1.1°C
8.9	20°F	-6.7°C
8.7	10°F	-12.2°C
8.5	0°F	-17.8°C

I. If the test voltage is below the minimum, replace the battery. If the test voltage is at or above the minimum, return the battery to service.

### Battery Charging

To minimize possible damage to the battery and allow the battery to be fully charged, the slow charging method is presented here. This charging method can be accomplished with a constant current battery charger which is available in most shops.

CAUTION

**Follow the manufacturer's instructions when using a battery charger.**

**NOTE:** Using specific gravity of the battery cells is the most accurate method of determining battery condition.

1. Determine the battery charge level from either its specific gravity or open circuit voltage.

Battery Charge Level	Specific Gravity	Open Circuit Voltage
100%	1.265	12.68
75%	1.225	12.45
50%	1.190	12.24
25%	1.155	12.06
0%	1.120	11.89

2. Determine the charging time and rate **using the manufacturer's battery charger instructions** or the following table.

Battery Reserve Capacity (Minutes)	Battery Charge Level (Percent of Fully Charged)			
	75%	50%	25%	0%
80 or less	3.8 hrs @ 3 amps	7.5 hrs @ 3 amps	11.3 hrs @ 3 amps	15 hrs @ 3 amps
81 to 125	5.3 hrs @ 4 amps	10.5 hrs @ 4 amps	15.8 hrs @ 4 amps	21 hrs @ 4 amps
126 to 170	5.5 hrs @ 5 amps	11 hrs @ 5 amps	16.5 hrs @ 5 amps	22 hrs @ 5 amps
171 to 250	5.8 hrs @ 6 amps	11.5 hrs @ 6 amps	17.3 hrs @ 6 amps	23 hrs @ 6 amps
above 250	6 hrs @ 10 amps	12 hrs @ 10 amps	18 hrs @ 10 amps	24 hrs @ 10 amps

CAUTION

**Do not charge a frozen battery because it can explode and cause injury. Let the battery warm to 60°F (15.5° C) before connecting to a charger.**

**Charge the battery in a well-ventilated place to dissipate gases produced from charging. These gases are explosive; keep open flame and electrical spark away from the battery. Do not smoke. Nausea may result if the gases are inhaled. Unplug the charger from the electrical outlet before connecting or disconnecting the charger leads from the battery posts.**

3. **Following the battery charger manufacturer's instructions**, connect the charger cables to the battery. Make sure a good connection is made.

4. Charge the battery **following the battery charger manufacturer's instructions**.

5. Occasionally check the temperature of the battery electrolyte. If the temperature exceeds 125°F (51.6°C) or the electrolyte is violently gassing or spewing, the charging rate must be lowered or temporarily stopped.

6. Three hours prior to the end of the charging, measure the specific gravity of a battery cell once per hour. The battery is fully charged when the cells are gassing freely at a low charging rate and there is less than a 0.003 change in specific gravity for three consecutive readings.



# Spray System

## Table of Contents

SPECIFICATIONS .....	2	Spray Control Assembly .....	20
GENERAL INFORMATION .....	3	Boom Valve Motor Assembly .....	22
Precautions Concerning Chemicals Used in Spray System .....	3	Agitation Valve Motor Assembly .....	24
Precautions for Removing or Adjusting Spray System Components .....	3	Boom and Agitation Valve Motor Service .....	26
SPRAY SYSTEM FLOW DIAGRAM .....	4	Boom Bypass .....	30
SPRAY SYSTEM OPERATION .....	5	Tank Suction .....	32
TROUBLESHOOTING .....	6	Tank Drain Valve (Serial Numbers below 230000400) .....	34
SERVICE AND REPAIRS .....	8	Tank Drain Valve (Serial Numbers 230000400 and above) .....	36
Suction Dampener .....	8	Turret Bodies .....	38
Pressure Dampener .....	9	Turret Body Service .....	39
Spray Pump .....	10	Boom Frame Breakaway Pivot Assembly .....	40
Spray Pump Service .....	12	Pro Control Spray System (Optional) .....	42
Agitation Nozzles (Tank Mounted) .....	16	Boom Actuator (Optional) .....	44
Pressure Relief Valve (Tank Mounted) .....	18	Boom Actuator Service .....	46

# Specifications

Item	Description
Spray Pump	Diaphragm Pump, 30 GPM (114 LPM) @ 200 PSI
Spray Pressure Relief Valve	Poppet Style, 220 PSI Maximum
Sprayer Tank	300 Gallon (1136 Liter), Polyethylene
Suction Strainer	50 Mesh (Blue), Stainless Steel, Tank Mounted (30 Mesh (Red) and 80 Mesh (Green) Optional)

# General Information

---

## Precautions Concerning Chemicals Used in Spray System

Chemicals can injure persons, animals, plants, soil, or other property. To eliminate environmental damage and personal injury:

1. Select the proper chemical for the job.

2. Carefully read the directions printed on the chemical manufacturer's labels before handling chemicals. Instructions on chemical manufacturer's container labels regarding mixing proportions should be read and strictly followed.

3. Keep spray material away from skin. If spray material comes in contact with a person, wash it off immediately in accordance with manufacturer's recommendations (container labels and Material Safety Data Sheets).

4. Always wear protective clothing, chemical resistant gloves, eye protection, and other personal protective equipment as recommended by the chemical manufacturer.

5. Properly dispose of chemical containers, unused chemicals, and chemical solution.

---

## Precautions for Removing or Adjusting Spray System Components

1. Stop the vehicle and set the parking brake.

2. Shut off the vehicle's engine and remove the key from the ignition switch.

3. Disengage all power and wait until all moving parts have stopped.

4. Remove chemicals from pump, hoses, and other spray components. Thoroughly neutralize and rinse spray system before loosening or removing any spray system component(s).

5. Make sure line pressure is relieved before loosening any system component.

# Spray System Flow Diagram

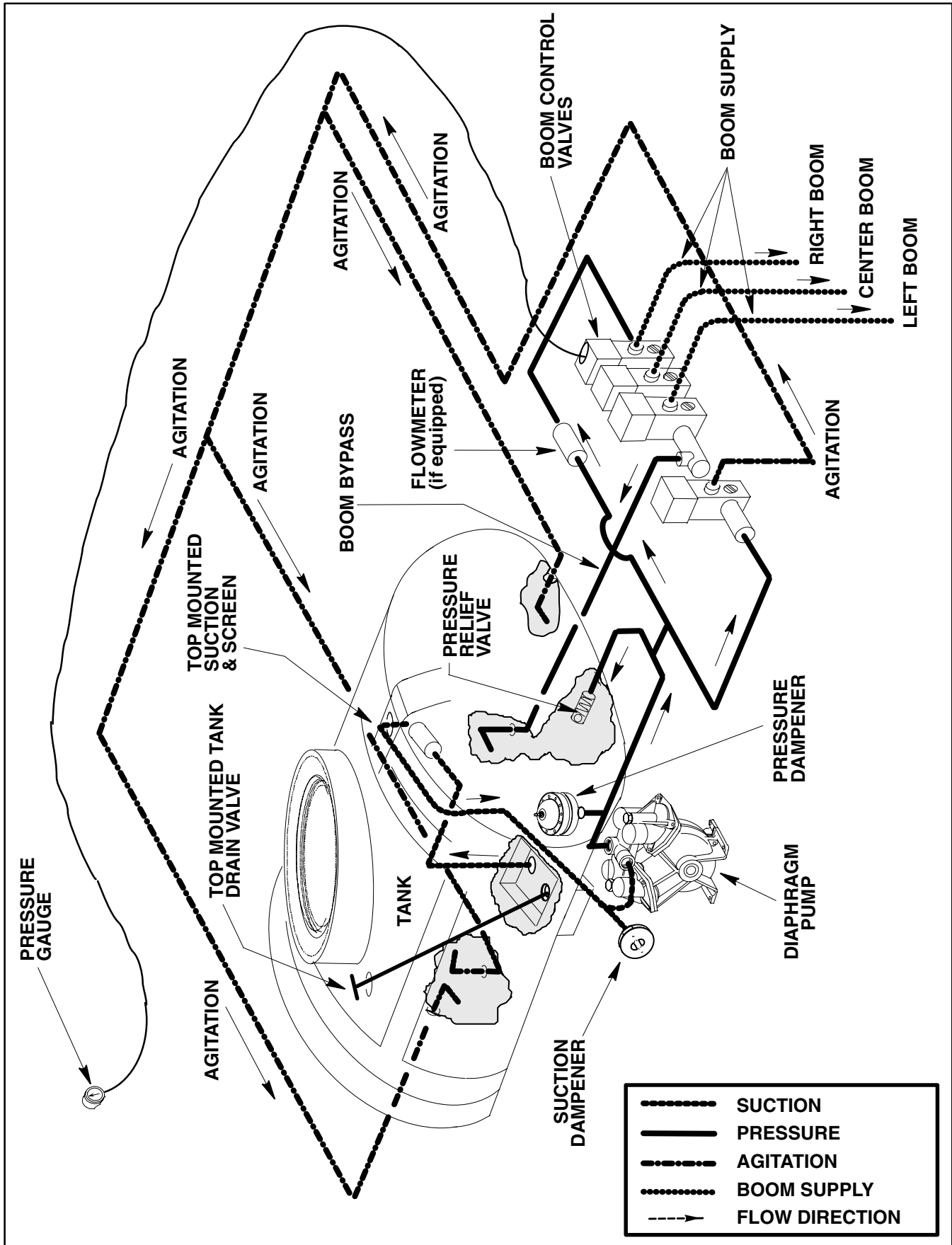

# Spray System Operation

The Multi Pro 5600 spray system uses a positive displacement diaphragm pump to move spray solution from the spray tank to the boom nozzles. The spray pump is self-priming and has a dry crankcase.

The downward stroke of the pumps' two connecting rods and diaphragms create suction to allow fluid to be drawn from the spray tank to the pump via the suction tube, suction strainer, hoses, and connectors. A suction dampener placed in the suction line dampens suction pulses to smooth suction flow. Suction valves positioned in the pump valve chamber prevent fluid from being pumped back into the suction line. Leaks in the suction line will cause system problems and often will be indicated by erratic suction line jumping and excessive pump noise.

Once to the pump, the fluid is pushed by the upward stroke of the pumps' two connecting rods and diaphragms to the pressure side of the spray system through hoses, connectors, control valves, and spray nozzles. A pressure dampener at the pump outlet smooths system pressure pulsation. Pressure valves positioned in the pump head prevent fluid from being drawn back into the pump. Maximum pressure in the system is limited by a pressure relief valve located in the tank. A pressure gauge on the dash panel indicates spray system pressure.

Battery current for spray system fuses, switches, valve motors, and other components is provided by the accessory solenoid when the machine ignition switch is in the RUN position. For spray system electrical component information and test procedures, see Chapter 5 – Electrical System.

The machine operator controls the spray system on the Multi Pro 5600 with electrical switches located on the spray console. Switches include a spray pump on/off switch, an application rate (increase/decrease) switch, an agitation control switch and three boom control switches. These switches control the PWM Valve, the agitation control valve and three boom control valves. Additionally, a master (foot) boom valve switch allows the operator to turn off/on all three boom sections.

The spray pump is directly coupled to and driven by a hydraulic motor. Flow from the hydraulic gear pump to the motor is controlled by the Pulse Width Modulated (PWM) Valve. Based on available current (mA) from the spray pump application rate (increase/decrease) switch, the PWM spool valve directs gear pump flow to the spray pump hydraulic motor. This hydraulic flow causes the motor to rotate the spray system pump for spray system operation.

When the spray pump is on, application rate (increase/decrease) switches allow the operator to adjust electrical current to the PWM Valve solenoid. Higher current (rate increase) to the PWM solenoid increases hydraulic flow to the spray pump motor and results in a higher spray pump speed with more output/pressure. Lower current (rate decrease) to the PWM solenoid decreases hydraulic flow to the spray pump motor and results in a lower spray pump speed with less output/pressure. Desired spray pump pressure should be based on boom nozzle selection and ground speed (see Nozzle Selection Guide (Toro Form No. 3329–580) for information regarding boom nozzle selection).

When the agitation switch is ON, the switch light is illuminated and the agitation control valve is opened. This open valve directs system flow to three agitation nozzles in the spray tank. When the agitation switch is OFF, the agitation control valve is closed so no flow is available for tank agitation nozzles.

When a boom control switch (left, center or right) is ON, the switch light is illuminated and the boom control valve for that boom is opened. This open valve directs system flow to the spray nozzles located on the boom section. When a boom control switch is OFF, the boom control valve is closed so no flow is available to that spray boom.

A manually adjustable boom bypass valve is incorporated in each of the boom control valves. Proper adjustment of the boom bypass valves prevents system pressure changes when a boom section is shut off. Flow from the boom bypass valves is directed back to the tank (boom bypass).

An optional Pro Control Spray System is available for the Multi Pro 5600. This system includes a console computer and an inline flowmeter to control the spray pressure system. The flowmeter is positioned in the pressure side of the spray system directly before the boom control valves. The flowmeter measures spray boom flow. The Pro Control computer determines system application rate based on operator programming and inputs from the flowmeter and the ground speed sensor located in the right rear wheel motor. Additional Pro Control information can be found in the Pro Control Spray System Operator's Manual.

# Troubleshooting

Problem	Possible Cause
Spray system leaks fluid.	Fitting(s), hose(s), or tube(s) are loose or damaged. O-ring(s) or seal(s) are missing or damaged. Spray tank drain valve not seating.
Fluid leaking from bottom of spray pump.	Faulty diaphragm(s) in spray pump.
Excessive suction hose vibration.	Suction screen in tank is plugged. Spray pump suction line has an air leak. Suction tube in spray tank has air leak. Suction line is restricted. Suction dampener diaphragm is damaged.
Spray pressure decreases while operating sprayer.	Suction line is restricted. Suction screen in tank is plugged. Agitation jet(s) in tank loose (only occurs if agitation switch is on). Spray nozzles worn or damaged. Pressure line or component is restricted or damaged. Engine speed is low. Pressure relief valve in tank is stuck. Spray pump is damaged.
Nozzles on spray boom section leak when boom is switched off.	Diaphragm in turret body is leaking or damaged. Boom valve motor for affected boom is not seating.
Spray pump doesn't rotate.	Spray pump switch off or damaged. Pressure increase/decrease switch not set. Key on spray pump or hydraulic motor shaft is sheared. Spray pump coupler assembly is damaged. Pump drive hydraulic motor not engaged or is damaged (see Chapter 4 - Hydraulic System). Pro Control (if equipped) not set up correctly.



<p>Erratic spray operation from booms.</p>	<p>Clogged strainer.</p> <p>Damaged suction dampener.</p> <p>Damaged pressure dampener.</p> <p>Clogged or damaged spray nozzle(s).</p> <p>Spray nozzles are different sizes.</p> <p>Console boom switch(es) dirty, corroded, or damaged.</p> <p>Boom valve motor seat loose or damaged.</p> <p>Boom valve motor actuating cam worn or sticking.</p> <p>Boom bypass set incorrectly.</p>
<p>No spray output from one spray boom.</p>	<p>Hoses on boom are pinched or kinked.</p> <p>Boom valve motor for affected boom not opening.</p> <p>Fuse for affected boom blown.</p> <p>Console boom switch for affected boom dirty, corroded, or damaged.</p> <p>Check for 12 volts at affected boom valve motor in both directions (on and off).</p>
<p>Low spray rate from one nozzle.</p>	<p>Clogged or damaged nozzle.</p> <p>Spray nozzles are different sizes.</p> <p>Boom valve motor for affected boom not seating.</p>

# Service and Repairs

## Suction Dampener

The suction dampener is mounted to the suction line at the spray pump (Fig. 1) and is used to dampen suction pulses to smooth suction flow. During normal pump operation, the suction dampener diaphragm will move.

**IMPORTANT: Make sure to neutralize and remove chemicals from pump and hoses before loosening and removing spray system components.**

A damaged suction dampener diaphragm will allow a suction leak and will cause improper pump operation. If the diaphragm is damaged, remove diaphragm from dampener housing and replace it (Fig. 2).

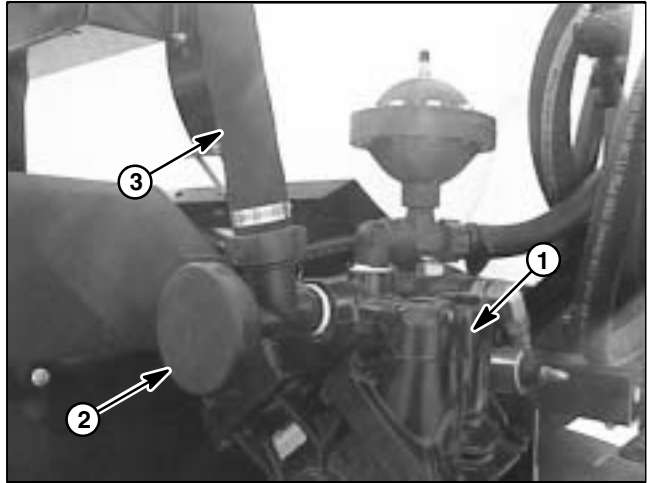

Figure 1

- 1. Spray pump
- 2. Suction dampener
- 3. Suction hose

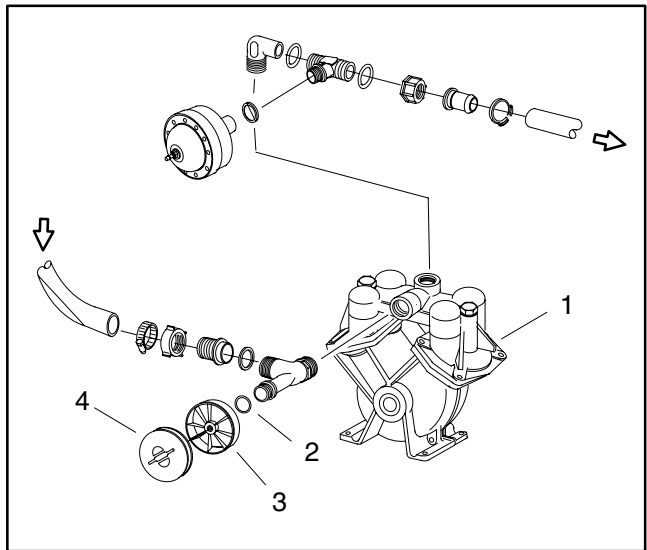

Figure 2

- 1. Spray pump
- 2. O-ring
- 3. Dampener housing
- 4. Diaphragm

## Pressure Dampener

The pressure dampener is mounted to the pressure line at the spray pump (Fig. 3) and is used to smooth system pressure pulsation. Adjust air pressure on the pressure dampener from 12 to 15 PSI (.83 to 1.03 bar).

**IMPORTANT: Any fluid in the pressure dampener will include spray system chemicals so take necessary precautions when working with the dampener. Use appropriate protective equipment: protective clothing, chemical resistant gloves, and eye protection.**

If fluid is present when pressure in the dampener is checked, the diaphragm in the pressure dampener is damaged and should be replaced.

### Dampener Service (Fig. 4)

**IMPORTANT: Make sure to neutralize and remove chemicals from pump and hoses before loosening and removing spray system components.**

1. Loosen and remove twelve (12) cap screws and nuts that secure diaphragm between housings.
2. Remove diaphragm from dampener.
3. Replace diaphragm and reassemble dampener.

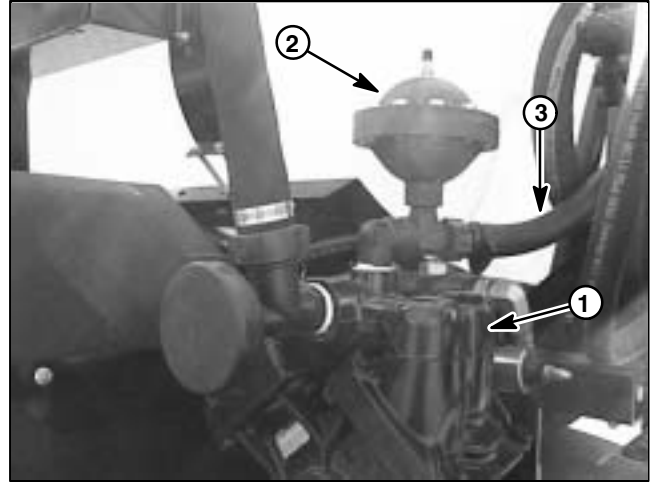

Figure 3

1. Spray pump
2. Pressure dampener
3. Pressure hose

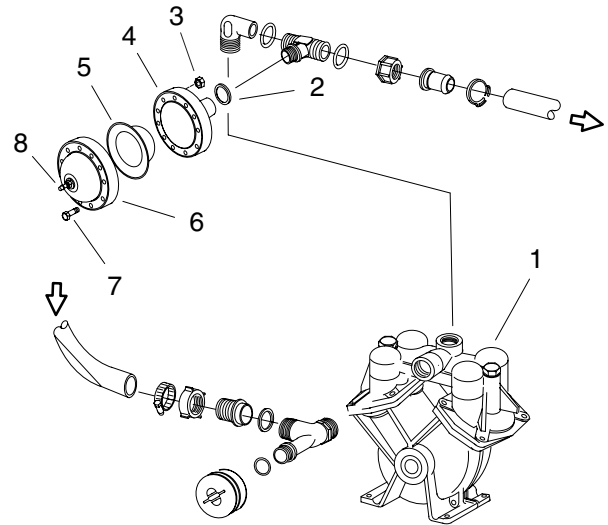

Figure 4

1. Spray pump
2. O-ring
3. Hex nut (12 used)
4. Rear housing
5. Diaphragm
6. Front housing
7. Cap screw (12 used)
8. Air valve

## Spray Pump

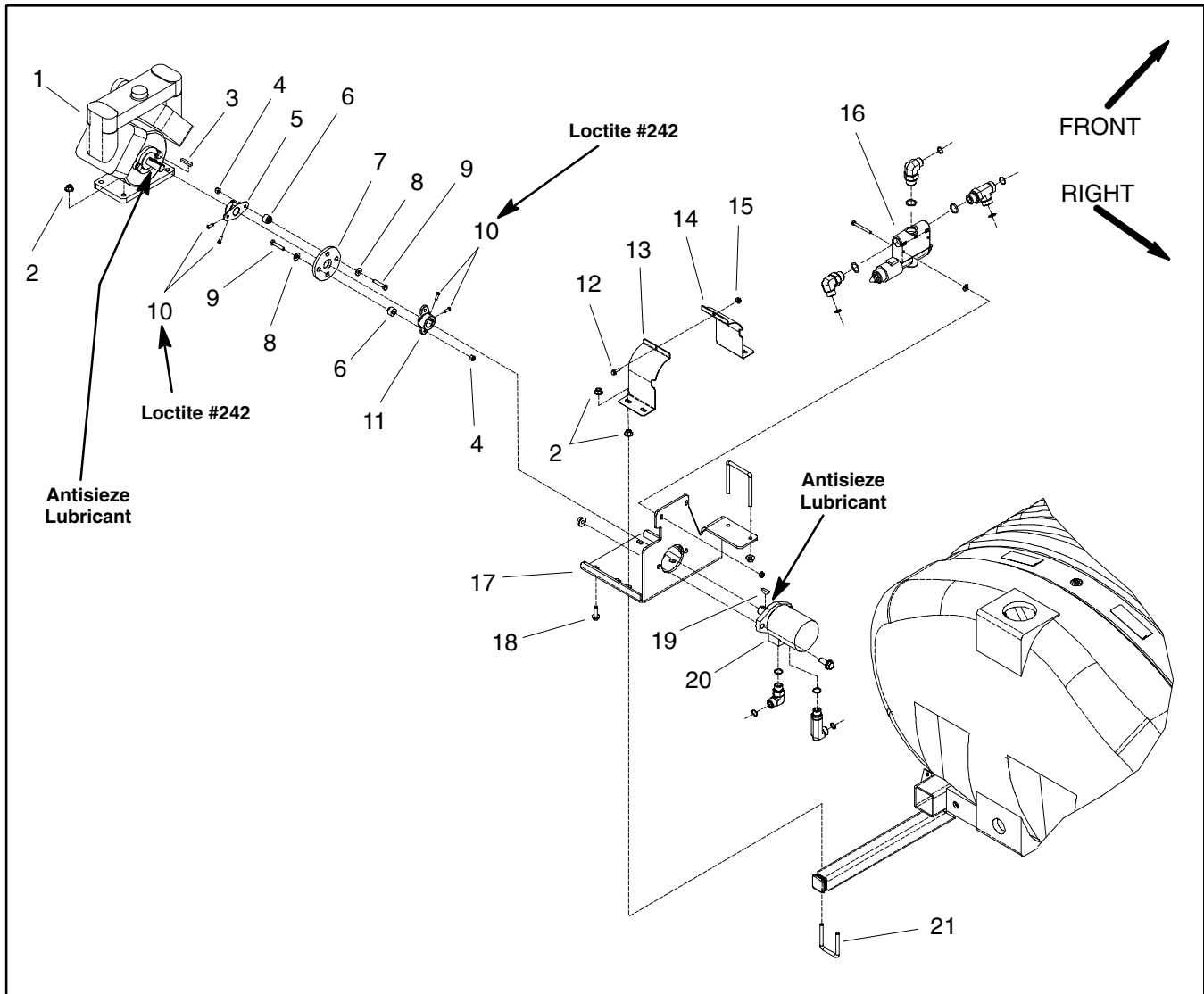

Figure 5

- |                        |                         |                                |
|------------------------|-------------------------|--------------------------------|
| 1. Spray pump assembly | 8. Flat washer          | 15. Flange nut                 |
| 2. Flange nut          | 9. Cap screw            | 16. PWM Valve                  |
| 3. Square key          | 10. Set screw           | 17. Pump mount bracket         |
| 4. Lock nut            | 11. Hydraulic motor hub | 18. Flange head screw (4 used) |
| 5. Pump hub            | 12. Flange head screw   | 19. Woodruff key               |
| 6. Coupler spacer      | 13. Rear guard plate    | 20. Hydraulic motor            |
| 7. Rubber coupling     | 14. Front guard plate   | 21. U-bolt (2 used)            |

**IMPORTANT: Make sure to neutralize and remove chemicals from pump and hoses before loosening and removing spray system components.**

### Removal (Fig. 5)

1. Park machine on a level surface, stop engine, engage parking brake, and remove key from the ignition switch.
2. Loosen hose clamp that secures suction hose to hose barb (Fig. 6). Pull suction hose from hose barb.

3. Loosen hose clamp that secures pressure hose to hose barb (Fig. 6). Pull pressure hose from hose barb.

4. Remove flange head screw and flange nut that secure front and rear guard plate. Remove four (4) flange nuts that retain guard plates to pump mount bracket. Remove guard plates from machine.

5. Remove lock nuts, flat washers, cap screws, and coupler spacers that secure rubber coupling to pump hub.

6. Remove four (4) flange head screws and flange nuts that secure pump to pump mount bracket.

7. Remove pump from machine.

8. If needed, loosen set screws in pump hub. Pull hub from pump shaft. Locate and remove key from pump shaft. Remove set screws from pump hub. Clean threads of set screws and hub.

9. If needed, remove pressure dampener, tee fitting (pressure), and elbow fitting (pressure) from pump outlet (Fig. 7).

10. If needed, remove suction dampener and tee fitting (suction) from pump inlet (Fig. 7).

### Installation (Fig. 5)

**NOTE:** Coat all o-rings with vegetable oil before installation to reduce the chance of damage during assembly.

1. Apply teflon tape to threads of removed tee fitting (pressure), elbow fitting (pressure), and tee fitting (suction). Position new o-rings and gaskets on suction and pressure fittings that were removed during disassembly.

2. If removed, install tee fitting (suction) and suction dampener to pump inlet. Orientate tee toward rear of machine (Fig. 7).

3. If removed, install elbow fitting (pressure), tee fitting (pressure), and pressure dampener to pump outlet. Orientate elbow toward rear of machine (Fig. 7).

4. If pump hub was removed, apply anti-seize lubricant to pump shaft. Install key in shaft and slide pump hub onto shaft.

5. Position pump on pump mounting bracket and install flange head screws and flange nuts to pump and mounting bracket. Leave fasteners loose.

6. Place coupling spacers into rubber coupling. Install cap screws, flat washers, and lock nuts to secure rubber coupling to pump hub. Make sure that cap screw threads extend through lock nut.

7. Secure pump to mounting bracket by tightening flange head screws and flange nuts.

8. If pump hub was removed, apply Loctite #242 (or equivalent) to threads of pump hub set screws. Install set screws into pump hub to secure hub to pump shaft.

9. Position front and rear guard plates to pump mount bracket. Install and tighten flange head screw and flange nut to guard plates. Install flange nuts to secure guard plates to pump mount bracket.

10. Install pressure and suction hoses to correct barb fittings (Fig. 6). Secure hoses with hose clamps.

Multi Pro 5600

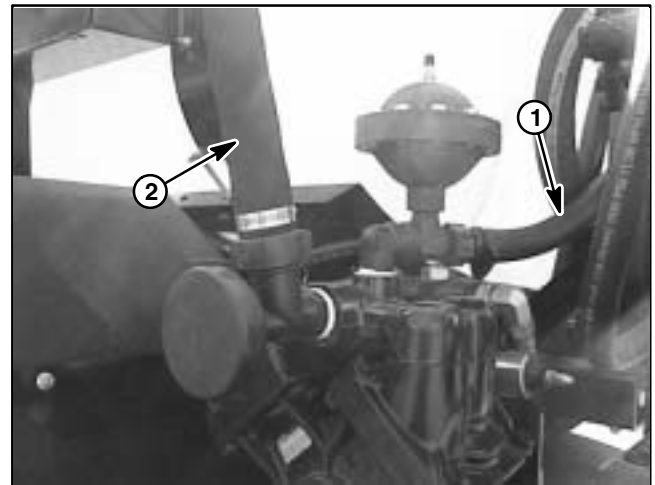

Figure 6

1. Pressure hose

2. Suction hose

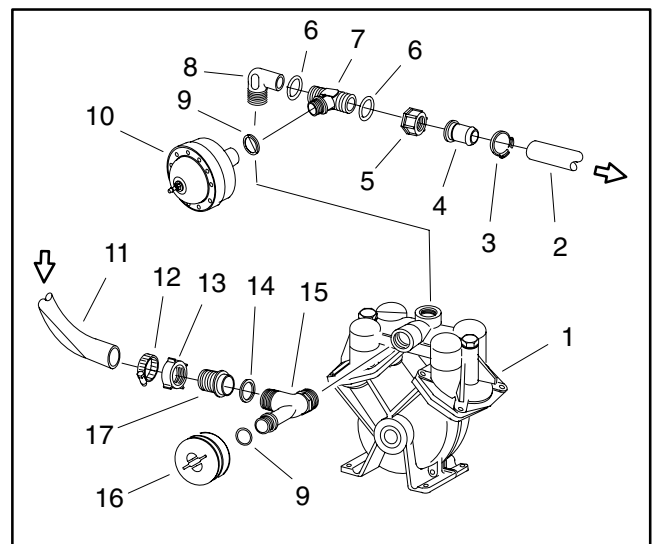

Figure 7

1. Spray pump

2. Pressure hose (1")

3. Hose clamp

4. Hose barb

5. Nut

6. Gasket

7. Tee fitting (pressure)

8. Elbow fitting (pressure)

9. O-ring

10. Pressure dampener

11. Suction hose (1 1/2")

12. Hose clamp

13. Nut

14. Seal

15. Tee fitting (suction)

16. Suction dampener

17. Hose barb

# Spray Pump Service

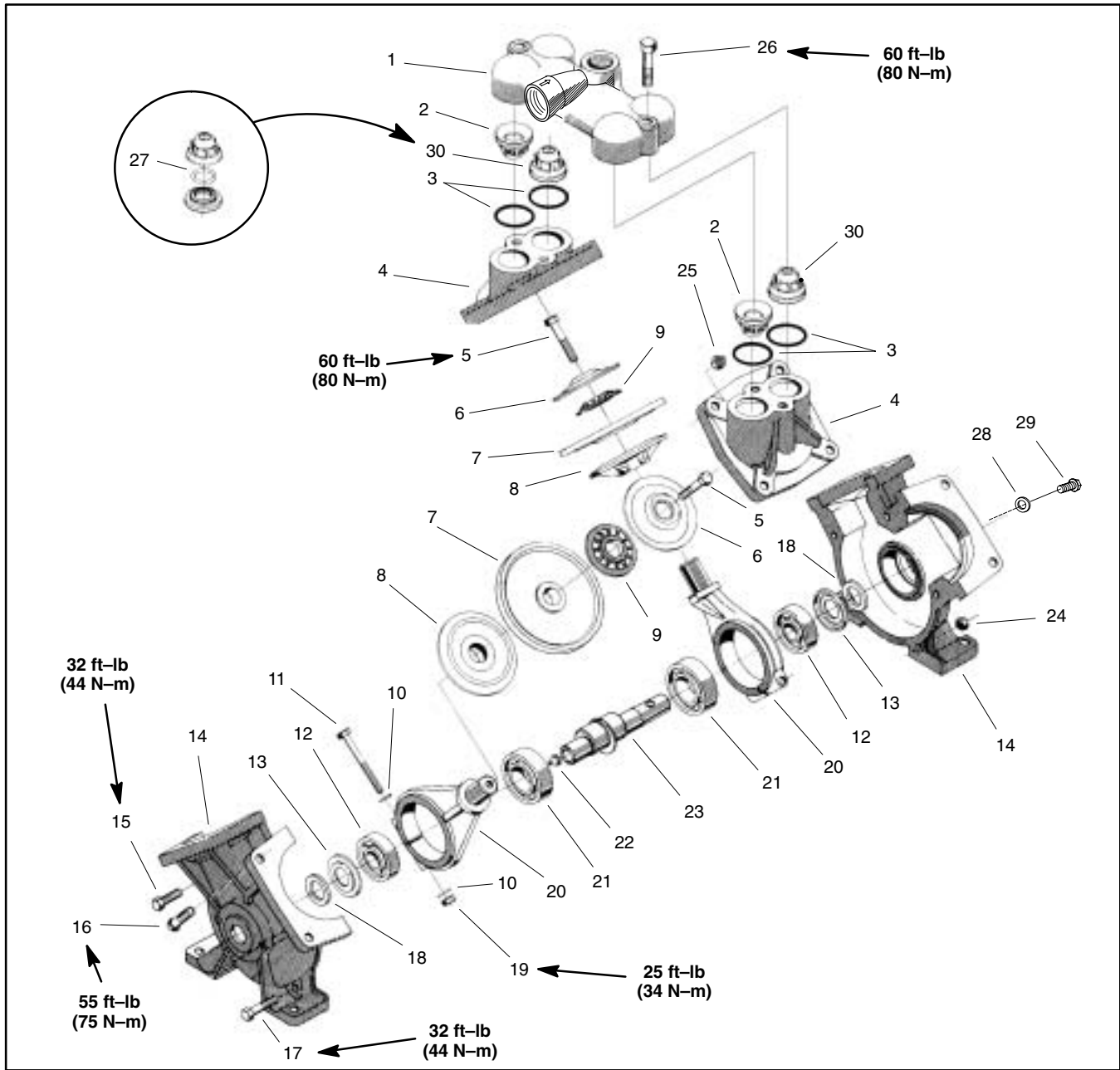

Figure 8

- |  |   |   |
|--|---|---|
| <ul style="list-style-type: none"> <li>1. Valve chamber</li> <li>2. Valve (inlet position)</li> <li>3. O-ring</li> <li>4. Diaphragm cover</li> <li>5. Hex bolt</li> <li>6. Washer</li> <li>7. Diaphragm</li> <li>8. Diaphragm back disc</li> <li>9. Nylon washer</li> <li>10. Lock washer</li> </ul> | <ul style="list-style-type: none"> <li>11. Hex bolt (M8)</li> <li>12. Ball bearing (crankshaft)</li> <li>13. Dust plate</li> <li>14. Pump casing</li> <li>15. Hex bolt (30 mm long) (3 used)</li> <li>16. Hex bolt (M12) (4 used per cover)</li> <li>17. Hex bolt (55 mm long) (2 used)</li> <li>18. Felt seal</li> <li>19. Hex nut (M8)</li> <li>20. Connecting rod</li> </ul> | <ul style="list-style-type: none"> <li>21. Ball bearing (connecting rod)</li> <li>22. Grease fitting</li> <li>23. Crankshaft</li> <li>24. Hex nut (5 used)</li> <li>25. Hex nut (M12) (4 used per cover)</li> <li>26. Hex bolt (2 used)</li> <li>27. Poly o-ring</li> <li>28. Lock washer</li> <li>29. Hex bolt</li> <li>30. Valve (outlet position)</li> </ul> |
|--|---|---|

**IMPORTANT:** The spray pump used on the Multi Pro may have SAE, metric, and Whitworth fasteners. To prevent component damage, take special care to identify correct location of all fasteners.

## Disassembly (Fig. 8)

**IMPORTANT: Make sure to remove and neutralize chemicals from pump before disassembly. Wear protective clothing, chemical resistant gloves, and eye protection during pump repair.**

**NOTE:** Many pump components can be easily reversed. During disassembly, make note of component position (e.g. crankshaft, valve chamber) to assure correct assembly.

1. Remove two (2) hex bolts that retain valve chamber to pump. Separate valve chamber from pump.
2. Remove inlet and outlet valves and o-rings from each diaphragm cover. Note orientation of valves. Discard valves and o-rings. Clean valve and o-ring seats in the valve chambers and diaphragm covers.
3. Remove hex bolts and nuts that secure diaphragm covers to pump. Remove diaphragm covers. Note: Some pumps may use bolts that thread into the pump casings to secure diaphragm covers.
4. Remove hex bolt, washer, nylon washer, diaphragm, and diaphragm back disc from each connecting rod. Discard diaphragms.
5. Remove five (5) hex bolts and nuts that secure pump casing halves together. Note location of two (2) longer hex bolts. Carefully separate pump casing halves.
6. Clean grease from bottom of housing and check condition of bearings on crankshaft. If bearings require replacement, remove and disassemble crankshaft:

- A. Remove crankshaft assembly from pump casing.
- B. Slide felt seal and dust plate from both ends of crankshaft.
- C. Loosen bolt and hex nut that secure connecting rods to crankshaft. Slide connecting rods from crankshaft.
- D. Press ball bearings from crankshaft.

## Assembly (Fig. 8)

1. If disassembled, reassemble crankshaft.
  - A. Hand pack new bearings with #2 general purpose lithium base grease.
  - B. Pressing on bearing inner race, install two connecting rod and two crankshaft ball bearings onto crankshaft.

C. Slide connecting rods onto rod bearings. Offsets of the connecting rods should face each other. Install hex bolt, flat washers, and hex nut to connecting rod. Torque hex nuts to 25 ft-lb (34 N-m) to secure connecting rod to crankshaft.

D. Position dust plate and felt seal on both ends of crankshaft.

**IMPORTANT: If connecting rod position is incorrect, pump will not operate properly.**

E. Slide crankshaft assembly into pump casing. The rear connecting rod should be positioned to the left side and the connecting rod closest to you to the right side (Fig. 9).

2. Place second pump casing onto assembly. Pump casing surfaces should mate together.

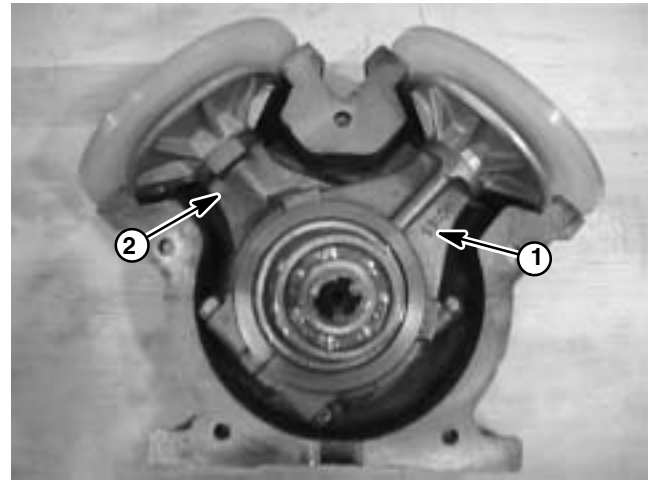

Figure 9

1. Closest connecting rod (to right side)
2. Rear connecting rod (to left side)

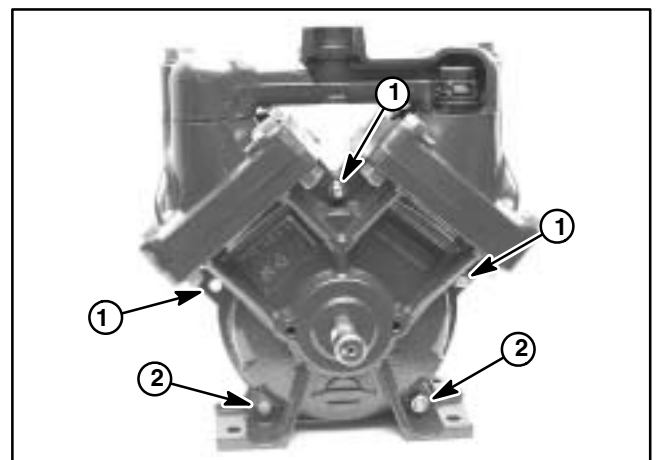

Figure 10

1. Hex bolt (30 mm long)
2. Hex bolt (55 mm long)

3. Install three (3) shorter (30 mm) and two (2) longer (55 mm) bolts into pump casing assembly (Fig. 10). Thread hex nuts onto bolts but do not fully tighten. Check that crankshaft turns freely.

4. Place diaphragm back disc and new diaphragm onto each connecting rod. The connecting rods should extend above the diaphragms when correctly installed (Fig. 11). Position nylon washer and washer on each connecting rod and then thread hex bolt into connecting rod. Torque bolt to 60 ft-lb (80 N-m).

5. Make sure that pump casings align and then secure pump casing assembly by torquing five (5) bolts to 32 ft-lb (44 N-m).

6. Install diaphragm covers to pump using hex bolts and nuts (4 per cover). Torque nuts to 55 ft-lb (75 N-m). Note: Some pumps may use hex bolts that thread into the pump casing to secure diaphragm covers.

7. Place new o-rings and valves into diaphragm cover openings (Fig. 12). Inlet valves should be installed with the spring down into the cover. Outlet valves should be installed in with the spring up and away from cover.

8. Place valve chamber over valves noting orientation of chamber inlet and outlet. Secure valve chamber with two (2) hex bolts. Torque bolts 60 ft-lb (80 N-m).

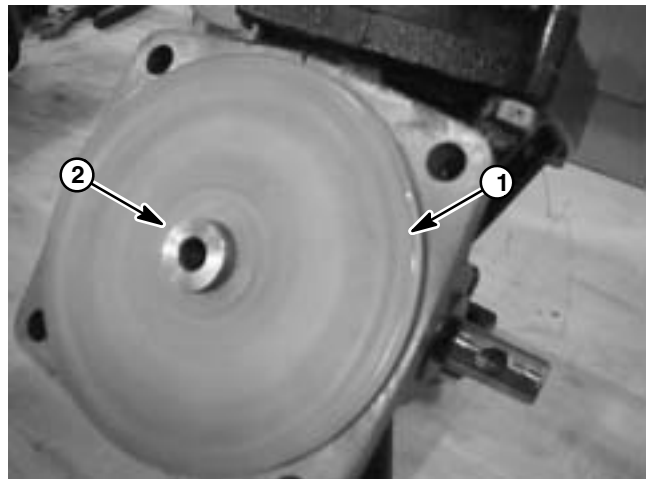

Figure 11

- 1. Diaphragm
- 2. Connecting rod

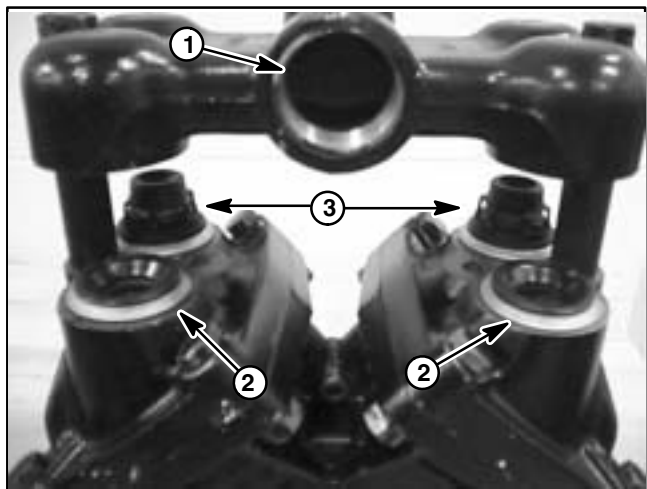

Figure 12

- 1. Inlet (suction)
- 2. Inlet valve
- 3. Outlet valve



This page is intentionally blank.

# Agitation Nozzles (Tank mounted)

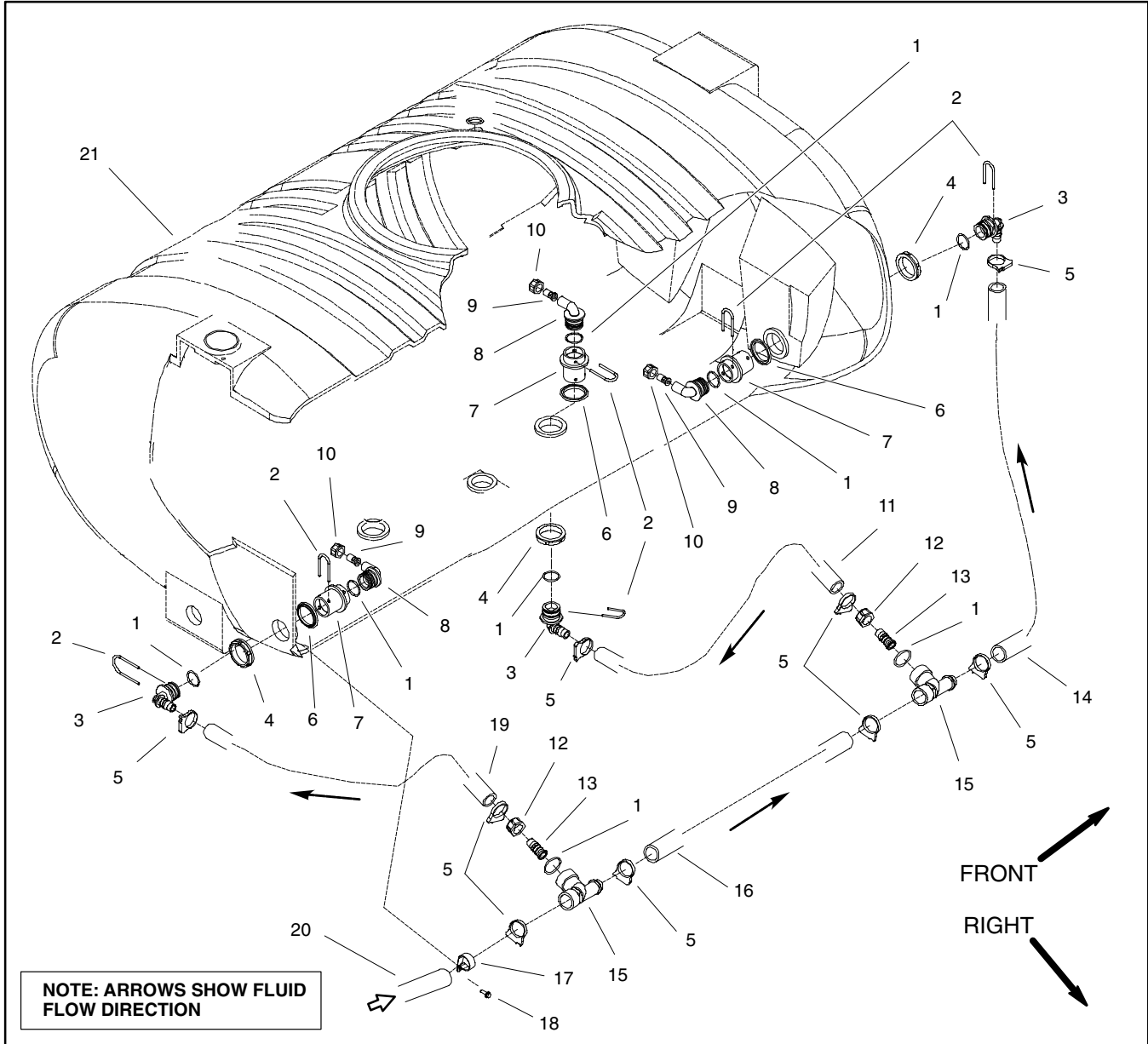

Figure 13

- |                     |                     |                                  |
|---------------------|---------------------|----------------------------------|
| 1. O-ring           | 8. Elbow fitting    | 15. Tee fitting                  |
| 2. Fork             | 9. Agitation nozzle | 16. Hose (3/4")                  |
| 3. Hosebarb         | 10. Nut             | 17. R clamp                      |
| 4. Bulkhead nut     | 11. Hose (3/4")     | 18. Flange head screw            |
| 5. Hose clamp       | 12. Nut             | 19. Hose (3/4")                  |
| 6. Bulkhead gasket  | 13. Hosebarb        | 20. Agitation supply hose (3/4") |
| 7. Bulkhead fitting | 14. Hose (3/4")     | 21. Spray tank                   |

**IMPORTANT:** Make sure to remove and neutralize chemicals from tank and other components before disassembly. Wear protective clothing, chemical resistant gloves, and eye protection during repair.

#### Disassembly (Fig. 13)

1. Park machine on a level surface, stop engine, engage parking brake, and remove key from the ignition switch.
2. Drain spray tank (see Operator's Manual).
3. Label disconnected hoses for proper installation after repairs are completed.
4. Remove agitation nozzles as required using Figure 13 as a guide. Discard all removed o-rings and gaskets.

#### Assembly (Fig. 13)

**NOTE:** Coat all o-rings with vegetable oil before installation to reduce the chance of damage during assembly.

1. Install agitation nozzles using Figure 13 as a guide. Replace all removed o-rings and gaskets.
2. Check spray system for leaks.

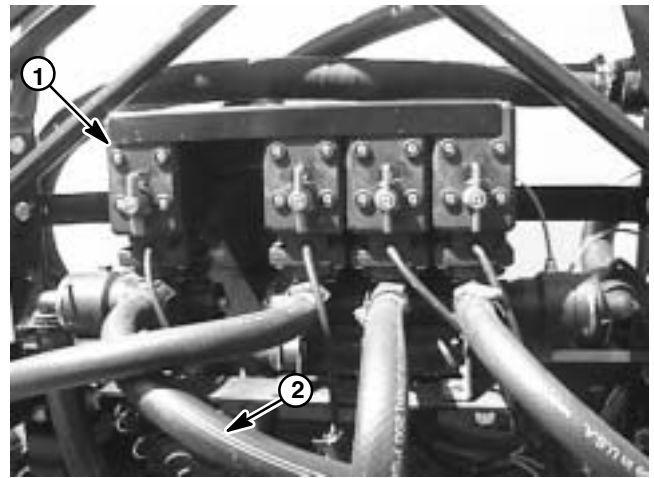

Figure 14

1. Agitation valve motor
2. Agitation supply hose

**Pressure Relief Valve (Tank Mounted)**

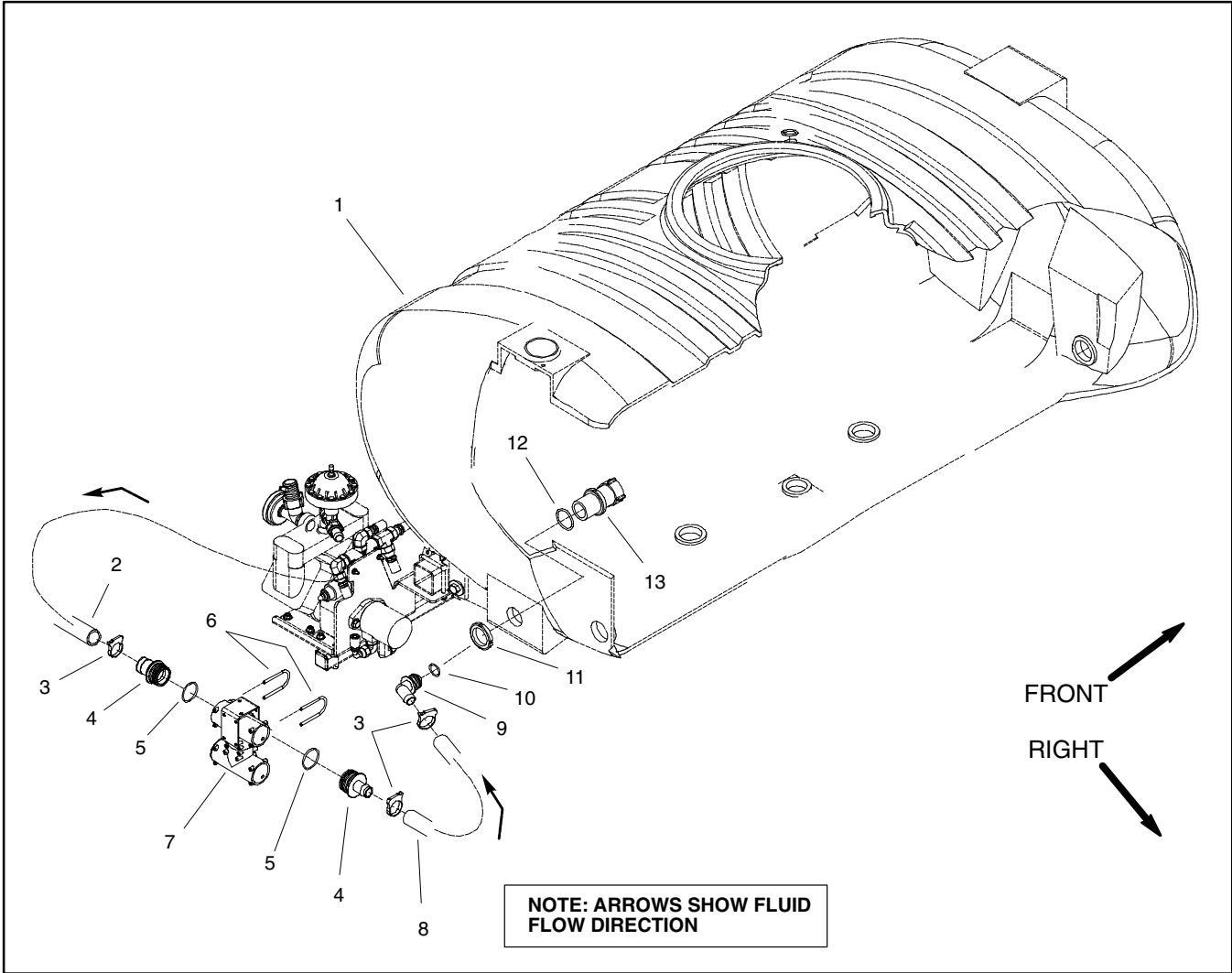

Figure 15

- |                              |                                    |                           |
|------------------------------|------------------------------------|---------------------------|
| 1. Spray tank                | 6. Fork                            | 10. O-ring                |
| 2. Pressure supply hose (1") | 7. Tee fitting assembly            | 11. Ringnut               |
| 3. Hose clamp                | 8. Pressure relief valve hose (1") | 12. Gasket                |
| 4. Hosebarb                  | 9. Hosebarb                        | 13. Relief valve assembly |
| 5. O-ring                    |                                    |                           |

**IMPORTANT:** Make sure to remove and neutralize chemicals from tank and other components before disassembly. Wear protective clothing, chemical resistant gloves, and eye protection during repair.

### Removal (Fig. 15)

1. Park machine on a level surface, stop engine, engage parking brake, and remove key from the ignition switch.
2. Drain spray tank (see Operator's Manual).
3. Label disconnected hoses for proper installation after repairs are completed.
4. Remove pressure relief valve from spray tank using Figures 15 and 16 as guides. Discard all removed o-rings and gaskets.
5. Disassemble relief valve using Figure 17 as a guide.

### Assembly (Fig. 15)

**NOTE:** Coat all o-rings with vegetable oil before installation to reduce the chance of damage during assembly.

1. Replace relief valve components that are worn or damaged. Assemble relief valve using Figure 17 as a guide.
2. Install pressure relief valve using Figures 15 and 16 as guides. Replace all removed o-rings and gaskets.
3. Check spray system for leaks.

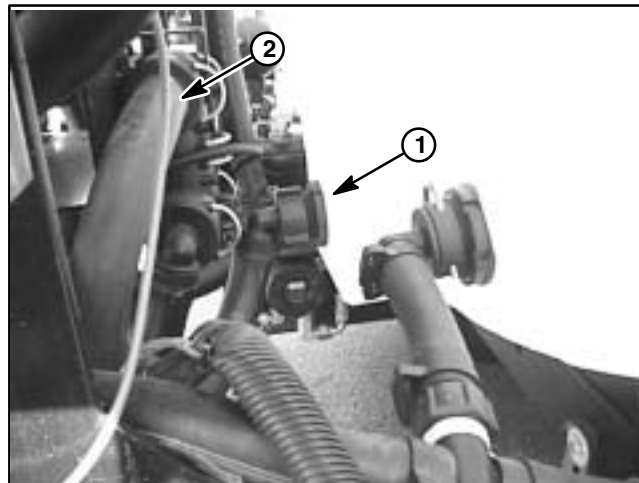

Figure 16

1. Pressure relief valve
2. Hose to pressure relief

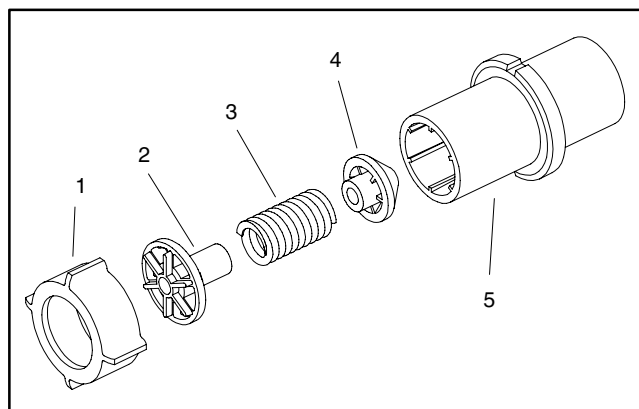

Figure 17

1. Nut
2. Seat
3. Spring
4. Cone
5. Relief valve housing

# Spray Control Assembly

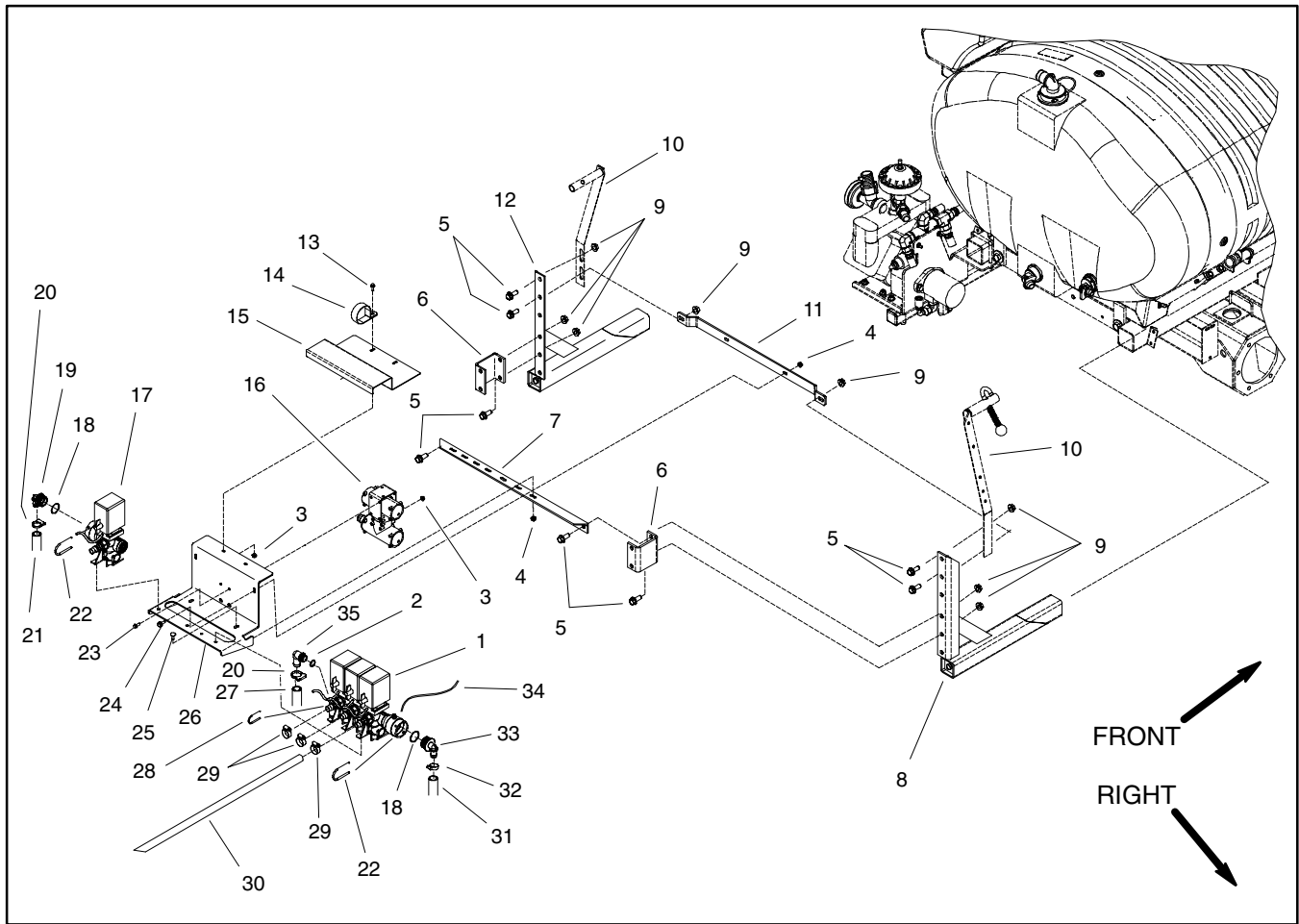

Figure 18

- |                              |                                |                               |
|------------------------------|--------------------------------|-------------------------------|
| 1. Boom valve motor assembly | 13. Flange head screw          | 25. Carriage bolt             |
| 2. O-ring                    | 14. R-clamp                    | 26. Mount bracket             |
| 3. Flange nut                | 15. Support bracket            | 27. Boom bypass hose (1")     |
| 4. Flange nut                | 16. Tee assembly               | 28. Fork                      |
| 5. Flange head screw         | 17. Agitation valve motor      | 29. Hose clamp                |
| 6. Boom mounting bracket     | 18. O-ring                     | 30. Boom supply hose (3 used) |
| 7. Cross support angle       | 19. Hosebarb                   | 31. Boom supply hose (1 1/2") |
| 8. RH boom mount             | 20. Hose clamp                 | 32. Hose clamp                |
| 9. Flange nut                | 21. Agitation supply hose (1") | 33. Hosebarb                  |
| 10. Boom hold-in assembly    | 22. Fork                       | 34. Pressure tube             |
| 11. Valve mounting bar       | 23. Flange head screw          | 35. Hosebarb                  |
| 12. LH boom mount            | 24. Flange head screw          |                               |

**IMPORTANT: Make sure to remove and neutralize chemicals from spray components before disassembly. Wear protective clothing, chemical resistant gloves, and eye protection during repair.**

### Removal (Fig. 18)

1. Park machine on a level surface, stop engine, engage parking brake, and remove key from the ignition switch.

2. Remove two (2) flange head screws and flange nuts that secure support bracket (item 15) to mount bracket (item 26). Position bracket away from spray control assembly.

3. Label hoses for proper installation after repairs are completed (Fig. 19). Loosen hose clamps and disconnect hoses from spray control assembly as needed.

4. If boom valve motor assembly is to be removed:
  - A. Unplug boom valve motor electrical connectors from machine wiring harness.
  - B. Remove pressure gauge tube from boom valve motor assembly.
  - C. Remove three (3) flange head screws and three (3) locknuts that secure boom valve motors to mount bracket (Fig. 20). Remove boom valve motor assembly from machine.

5. If agitation valve motor is to be removed:
  - A. Unplug agitation valve motor electrical connectors from machine wiring harness.
  - B. Remove flange head screw and locknut that secure agitation valve motor to mount bracket (Fig. 20). Remove agitation valve motor from machine.

6. Remove additional spray control components as required using Figure 18 as a guide. Discard all removed o-rings and gaskets.

**Assembly (Fig. 18)**

**NOTE:** Coat all o-rings with vegetable oil before installation to reduce the chance of damage during assembly.

1. Install spray control components using Figure 18 as a guide. Replace all removed o-rings and gaskets.
2. Position removed motor assembly to mount bracket and secure with fasteners removed during disassembly (Fig. 20).
3. Secure support bracket to mount bracket with two (2) flange head screws and flange nuts.
4. Install hoses to correct locations on spray control assembly (Fig. 19). Secure hoses with hose clamps.
5. If removed, install pressure gauge tube to boom valve motor assembly.
6. Plug electrical connectors from valve motor(s) to machine electrical harness.
7. Operate spray system and check for leaks.

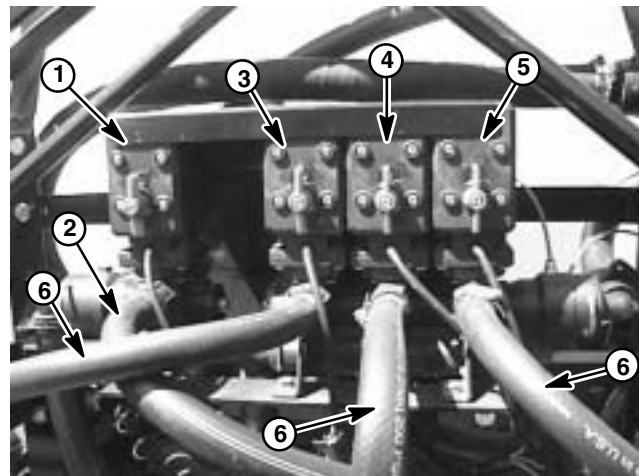

Figure 19

- |                          |                            |
|--------------------------|----------------------------|
| 1. Agitation valve motor | 4. Center boom valve motor |
| 2. Agitation supply hose | 5. RH boom valve motor     |
| 3. LH boom valve motor   | 6. Boom supply hose        |

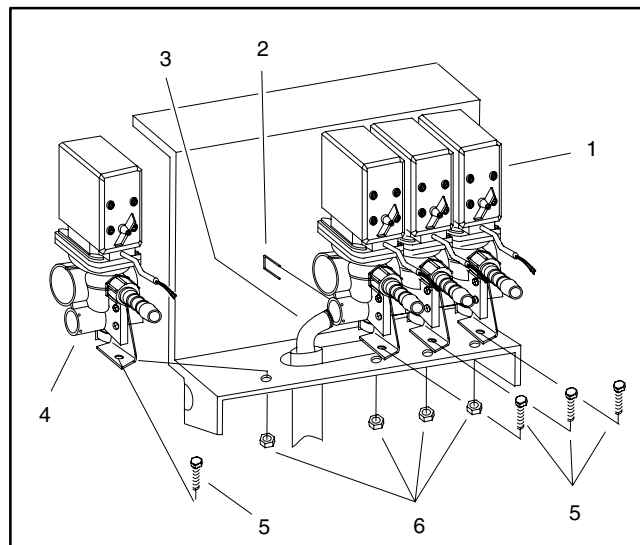

Figure 20

- |                      |                          |
|----------------------|--------------------------|
| 1. Boom valve motors | 4. Agitation valve motor |
| 2. Fork              | 5. Flange head screw     |
| 3. Boom bypass hose  | 6. Flange nut            |

# Boom Valve Motor Assembly

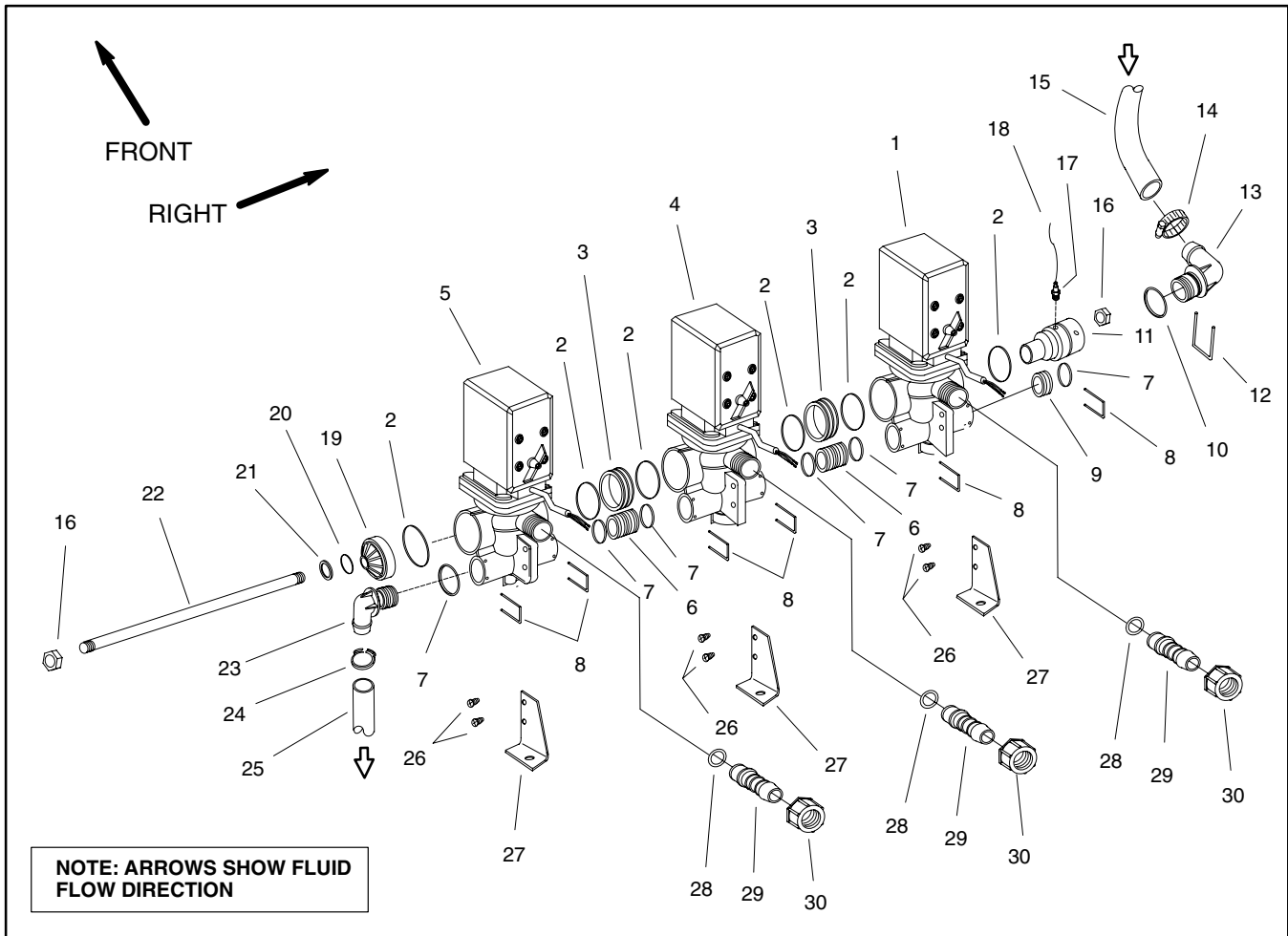

Figure 21

- |                            |                               |                           |
|----------------------------|-------------------------------|---------------------------|
| 1. RH boom valve motor     | 11. Connector                 | 21. Washer                |
| 2. O-ring                  | 12. Fork                      | 22. Rod                   |
| 3. Valve joiner            | 13. Hosebarb                  | 23. Hosebarb              |
| 4. Center boom valve motor | 14. Hose clamp                | 24. Hose clamp            |
| 5. LH boom valve motor     | 15. Boom supply hose (1 1/2") | 25. Boom bypass hose (1") |
| 6. Boom bypass joiner      | 16. Nut                       | 26. Screw                 |
| 7. O-ring                  | 17. Tube coupler              | 27. Mounting bracket      |
| 8. Fork                    | 18. Pressure tube             | 28. O-ring                |
| 9. End cap                 | 19. End cover                 | 29. Hosebarb (boom hose)  |
| 10. O-ring                 | 20. O-ring                    | 30. Nut                   |



**IMPORTANT:** Make sure to remove and neutralize chemicals from spray components before disassembly. Wear protective clothing, chemical resistant gloves, and eye protection during repair.

#### Disassembly (Fig. 21)

1. Separate boom valve motors as needed using Figures 21 and 22 as guides. Discard all removed o-rings and gaskets.
2. See Boom and Agitation Valve Motors in this section for disassembly and reassembly information of boom valve motor.

#### Assembly (Fig. 21)

**NOTE:** Coat all o-rings with vegetable oil before installation to reduce the chance of damage during assembly.

1. Reassemble boom valve motor assembly using Figures 21 and 22 as guides. Replace all removed o-rings.
2. Before installing rod (Item 22) into assembly, thread nut (item 16) fully onto rod end that has fewer threads. Make sure that o-ring (Item 20) is not damaged during installation over rod.
3. Install boom valve motor assembly on machine (see Spray Control Assembly in this section).
4. Operate spray system and check for leaks.

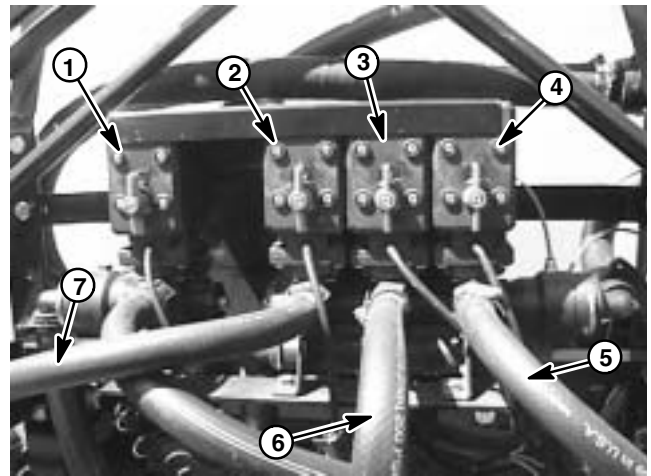

Figure 22

- |                            |                        |
|----------------------------|------------------------|
| 1. Agitation valve motor   | 5. RH boom supply hose |
| 2. LH boom valve motor     | 6. Center boom supply  |
| 3. Center boom valve motor | 7. LH boom supply hose |
| 4. RH boom valve motor     |                        |

# Agitation Valve Motor Assembly

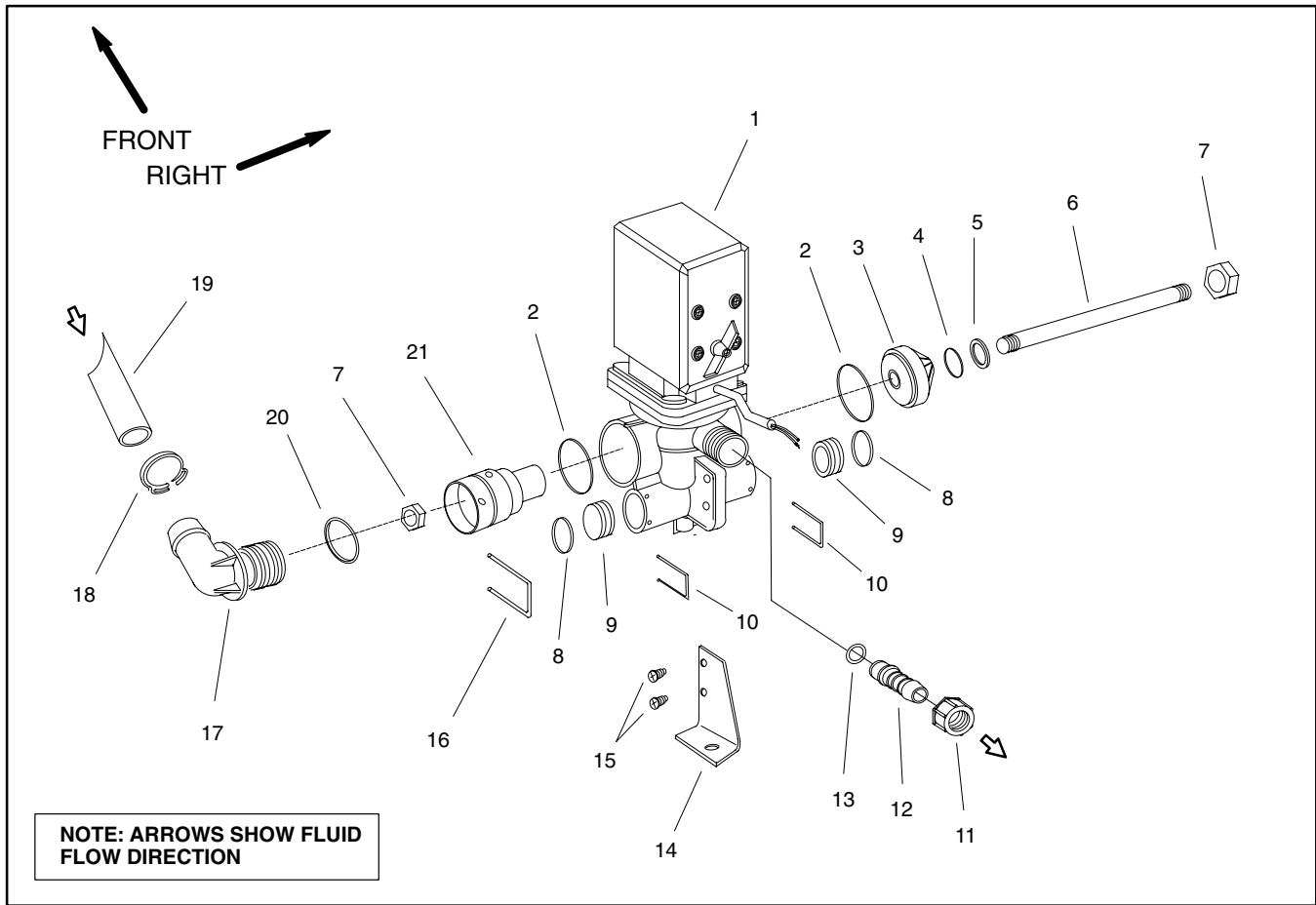

Figure 23

- |                          |                      |                           |
|--------------------------|----------------------|---------------------------|
| 1. Agitation valve motor | 8. O-ring            | 15. Screw                 |
| 2. O-ring                | 9. End cap           | 16. Fork                  |
| 3. End cover             | 10. Fork             | 17. Hosebarb              |
| 4. O-ring                | 11. Nut              | 18. Hose clamp            |
| 5. Washer                | 12. Hosebarb         | 19. Agitation supply hose |
| 6. Rod                   | 13. O-ring           | 20. O-ring                |
| 7. Nut                   | 14. Mounting bracket | 21. Connector             |

The agitation switch on the spray console is used to energize the agitation valve motor and open the valve. The open valve allows system flow to reach the three agitation nozzles located in the spray tank.

**IMPORTANT: Make sure to remove and neutralize chemicals from spray components before disassembly. Wear protective clothing, chemical resistant gloves, and eye protection during repair.**

### Disassembly (Fig. 23)

1. Disassemble agitation valve motor as needed using Figures 23 and 24 as guides. Discard all removed o-rings and gaskets.

2. See Boom and Agitation Valve Motors in this section for disassembly and reassembly information of the agitation valve motor.

### Assembly (Fig. 23)

**NOTE:** Coat all o-rings with vegetable oil before installation to reduce the chance of damage during assembly.

1. Reassemble agitation valve motor assembly using Figures 23 and 24 as guides. Replace all removed o-rings.

2. Install agitation valve motor assembly on machine (see Spray Control Assembly in this section).

3. Operate spray system and check for leaks.

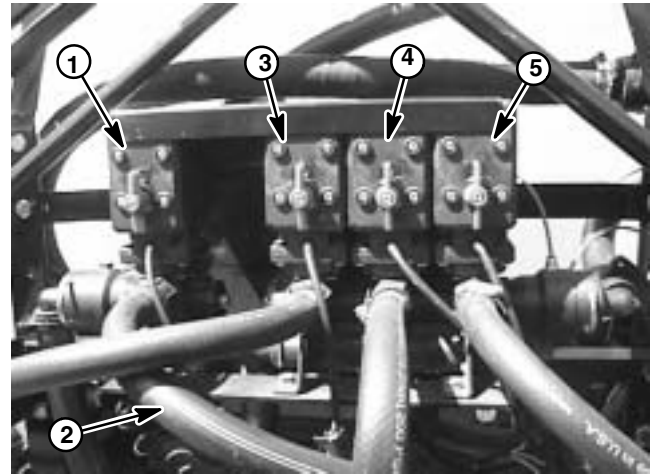

Figure 24

- |                          |                            |
|--------------------------|----------------------------|
| 1. Agitation valve motor | 4. Center boom valve motor |
| 2. Agitation supply hose | 5. RH boom valve motor     |
| 3. LH boom valve motor   |                            |

## Boom and Agitation Valve Motor Service

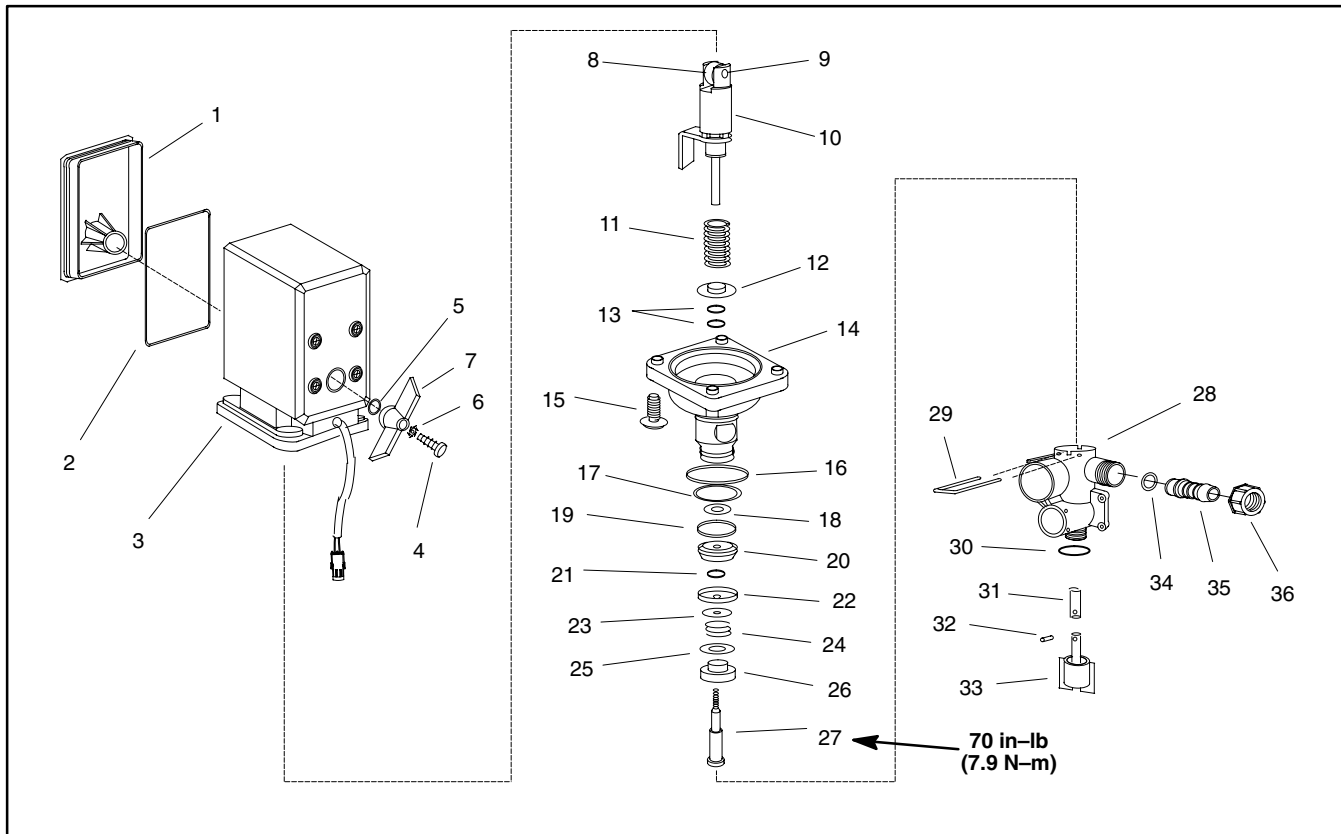

Figure 25

- |                        |                                  |                          |
|------------------------|----------------------------------|--------------------------|
| 1. Housing cover       | 13. O-ring                       | 25. Flat washer          |
| 2. Cover seal          | 14. Spindle housing              | 26. Cone                 |
| 3. Valve motor         | 15. Phillips head screw (4 used) | 27. Screw                |
| 4. Phillips head screw | 16. O-ring                       | 28. Manifold housing     |
| 5. O-ring              | 17. O-ring                       | 29. Fork                 |
| 6. Lock washer         | 18. Flat washer                  | 30. O-ring               |
| 7. Hand grip           | 19. Seat outer o-ring            | 31. Balancing valve      |
| 8. Roller              | 20. Seat                         | 32. Roll pin             |
| 9. Roller pin          | 21. Seat inner o-ring            | 33. Balancing valve knob |
| 10. Spindle            | 22. Seat base                    | 34. O-ring               |
| 11. Spring             | 23. Flat washer                  | 35. Hosebarb             |
| 12. Spring seat        | 24. Spring                       | 36. Nut                  |

The Multi Pro 5600 uses three valve motor assemblies to control the spray booms and one valve motor to control tank agitation (Fig. 26). Each of these motor assemblies includes a motor section (Items 1 through 7 in Figure 25), a spindle section (Items 8 through 27 in Figure 25), and a manifold assembly (Items 28 through 36 in Figure 25).

### Disassembly and Inspection (Fig. 25)

**IMPORTANT: Make sure to remove and neutralize chemicals from spray components before disassembly. Wear protective clothing, chemical resistant gloves, and eye protection during repair.**

1. Remove valve motor assembly from machine (see Agitation Valve Motor Assembly or Boom Valve Motor Assembly in this section).

2. To remove the motor and spindle section assembly from the manifold assembly:

A. Remove the fork (item 29) that secures the motor and spindle sections to the manifold assembly.

B. Lift the motor and spindle section assembly from the manifold.

3. To allow easier separation of the motor and spindle sections, make sure that valve motor is in the closed position (green indicator is recessed into the spindle housing). Remove four phillips head screws (item 15) and separate spindle section from motor section.

4. Remove rear housing cover from valve motor to inspect motor components.

A. Cam should be tight on shaft. Cam surface should be free of wear and/or scoring.

B. The inside of motor housing should be free of excessive moisture, corrosion, and dirt.

C. The cam bearing surface in the housing cover should be inspected for excessive wear.

5. Inspect and disassemble spindle section (Fig. 27).

A. Inspect spindle roller surface for wear or scoring. Check that spindle roller rotates freely on roller pin. Replace roller and/or pin as required.

B. The spindle can be disassembled by removing the screw at the bottom of the spindle shaft. Take note of washer, spring, seat, and o-ring locations as spindle is removed.

C. Inspect the cone located at the bottom of the spindle. The cone should be free of nicks or worn spots. A damaged cone will allow flow to the boom bypass rather than to the spray boom.

D. The seat o-rings allow the spindle to shut off flow to the spray boom. If boom nozzles leak when the boom is shut off, the seat and seat o-rings should be inspected carefully.

6. If leakage occurs from balancing valve knob at bottom of boom valve manifold (Fig. 28):

A. Carefully remove roll pin that secures balancing valve to knob.

B. Remove knob from manifold. Remove and discard o-ring.

C. Inspect seating surfaces of manifold and balancing valve. Clean or replace components as needed.

### Assembly (Fig. 25)

**NOTE:** Coat all o-rings with vegetable oil before installation to reduce the chance of damage during assembly.

1. Replace all removed o-rings.

2. If boom valve manifold was disassembled (Fig. 28):

A. Install o-ring, balancing valve, and knob to manifold.

B. Secure balancing valve to knob by carefully installing roll pin.

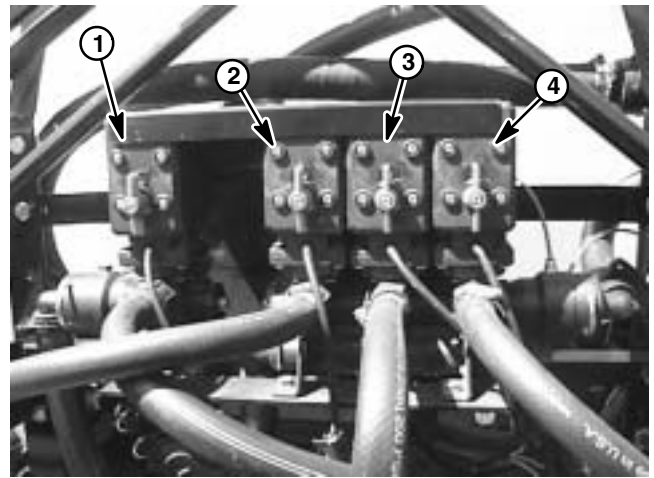

Figure 26

- 1. Agitation valve motor
- 2. LH boom valve motor
- 3. Center boom valve motor
- 4. RH boom valve motor

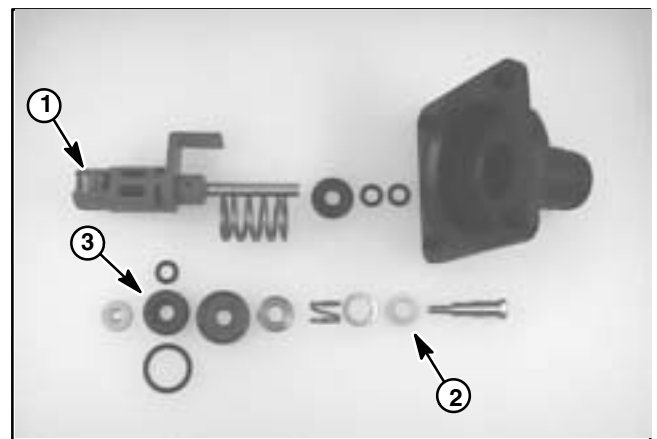

Figure 27

- 1. Spindle roller
- 2. Cone
- 3. Seat

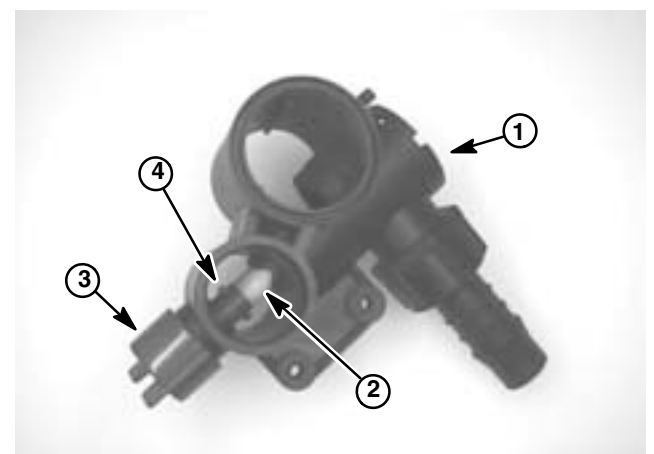

Figure 28

- 1. Boom valve manifold
- 2. Balancing valve
- 3. Balancing valve knob
- 4. Roll pin

3. Assemble spindle section by reversing disassembly process. Align green indicator tab on spindle to slot in spindle housing. Install screw into bottom of spindle to secure assembly. Torque screw 70 in-lb (7.9 N-m).
4. Position spindle section on motor section so that green indicator on spindle section is opposite the motor hand grip. Secure spindle section to motor section with four phillips head screws (item 15).
5. Replace rear housing to valve motor.
6. Position the motor and spindle section assembly to the manifold assembly. The motor hand grip and boom supply hosebarb on manifold should be on the same side of the assembly. Install the fork (item 29) to secure the motor and spindle sections to the manifold.
7. Assemble valve motor assembly. (see Boom Valve Motor Assembly or Agitation Valve Motor Assembly in this section).
8. Install valve motor assembly to machine (see Spray Control in this section).
9. Operate spray system and check for leaks.

This page is intentionally blank.

# Boom Bypass

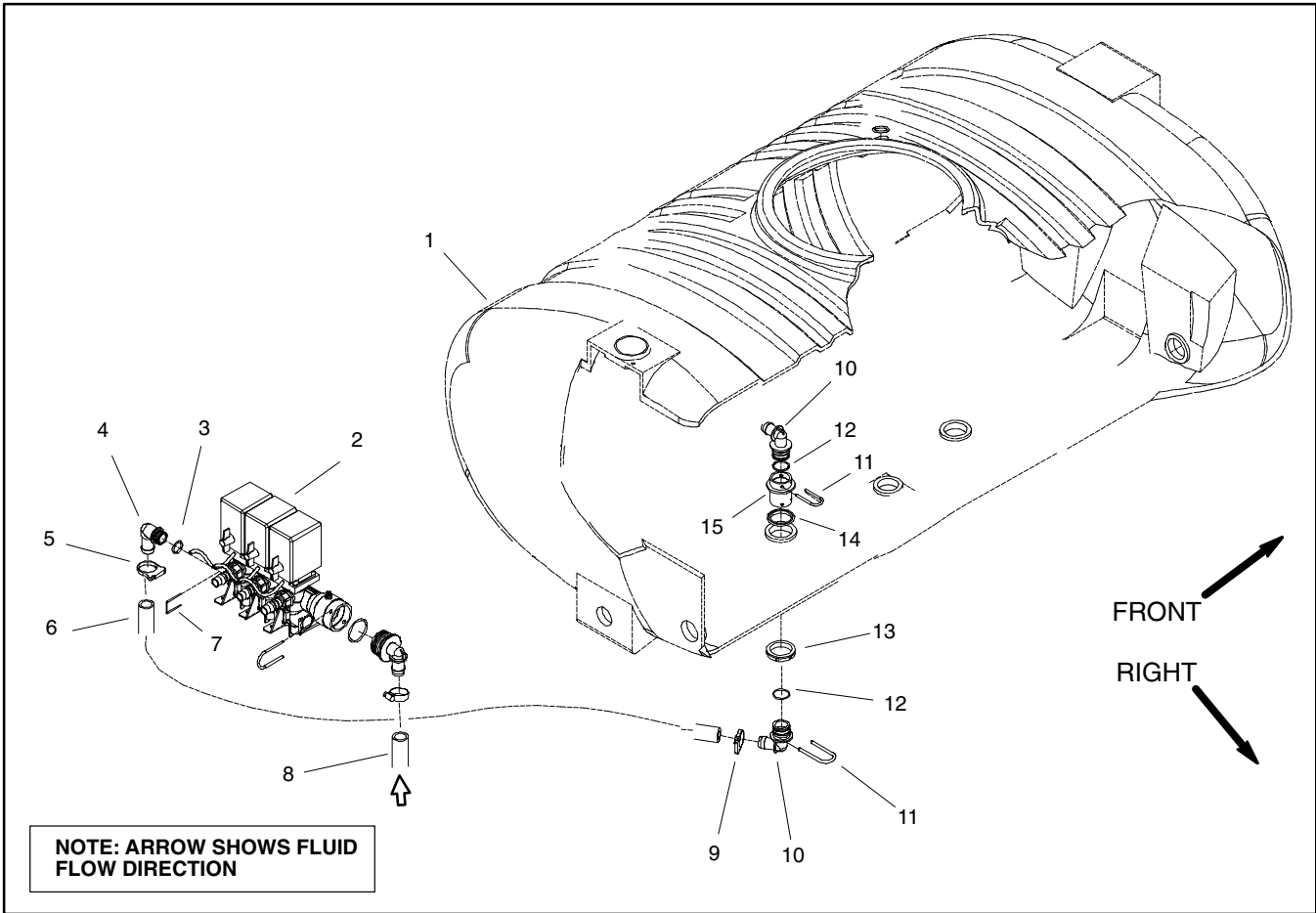

Figure 29

- 1. Spray tank
- 2. Boom valve motor assembly
- 3. O-ring
- 4. Hosebarb
- 5. Hose clamp

- 6. Boom bypass hose (1")
- 7. Fork
- 8. Boom supply hose (1 1/2")
- 9. Hose clamp
- 10. Elbow fitting

- 11. Fork
- 12. O-ring
- 13. Bulkhead nut
- 14. Bulkhead gasket
- 15. Bulkhead



### Disassembly (Fig. 29)

**IMPORTANT: Make sure to remove and neutralize chemicals from tank and spray components before disassembly. Wear protective clothing, chemical resistant gloves, and eye protection during repair.**

1. Park machine on a level surface, stop engine, engage parking brake, and remove key from the ignition switch.
2. Drain spray tank (see Operator's Manual).
3. Disassemble boom bypass using Figure 29 as a guide. Discard all removed o-rings and gaskets.

### Assembly (Fig. 29)

**NOTE:** Coat all o-rings with vegetable oil before installation to reduce the chance of damage during assembly.

1. Assemble boom bypass using Figure 29 as a guide. Replace all removed o-rings and gaskets.
2. Check spray tank for leaks.

# Tank Suction

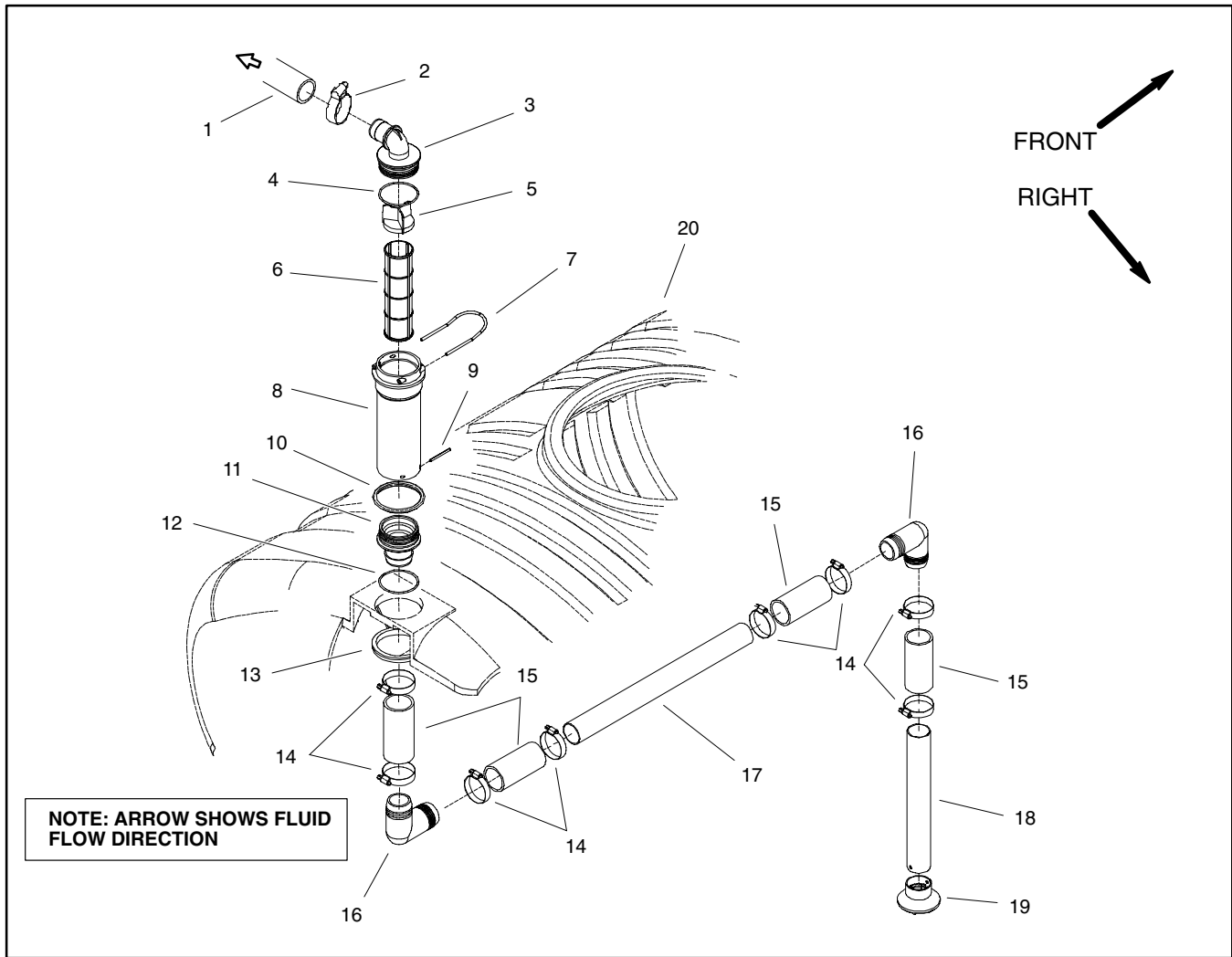

Figure 30

- 1. Suction hose (1 1/2")
- 2. Hose clamp
- 3. Hosebarb
- 4. O-ring
- 5. Suction screen vane
- 6. Suction screen
- 7. Fork

- 8. Filter housing
- 9. Expansion pin (2 used)
- 10. Gasket
- 11. Hosebarb
- 12. O-ring
- 13. Bulkhead nut
- 14. Hose clamp

- 15. Suction hose
- 16. Elbow
- 17. Suction tube
- 18. Suction tube
- 19. Suction tube foot
- 20. Spray tank

**NOTE:** If suction tube in tank develops an air leak, spray performance will diminish when tank level reaches the leak.

### Removal (Fig. 30)

**IMPORTANT:** Make sure to remove and neutralize chemicals from tank and spray components before disassembly. Wear protective clothing, chemical resistant gloves, and eye protection during repair.

1. Park machine on a level surface, stop engine, engage parking brake, and remove key from the ignition switch.
2. Remove suction strainer from spray tank (see Operator's Manual).
3. Raise tank lid and remove strainer basket to gain access to suction tube inside spray tank.
4. Remove suction tube assembly from spray tank and disassemble tube using Figure 13 as a guide. Discard all removed o-rings and gaskets.

### Assembly (Fig. 30)

**NOTE:** Coat all o-rings with vegetable oil before installation to reduce the chance of damage during assembly.

1. Assemble and install suction tube assembly using Figure 30 as a guide. Replace all removed o-rings and gaskets.
2. Check spray tank for leaks.

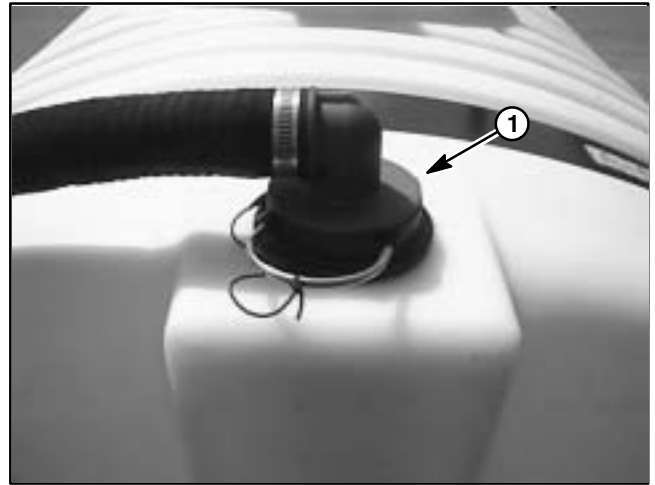

Figure 31

1. Suction strainer location

**Tank Drain Valve (Serial Numbers below 230000400)**

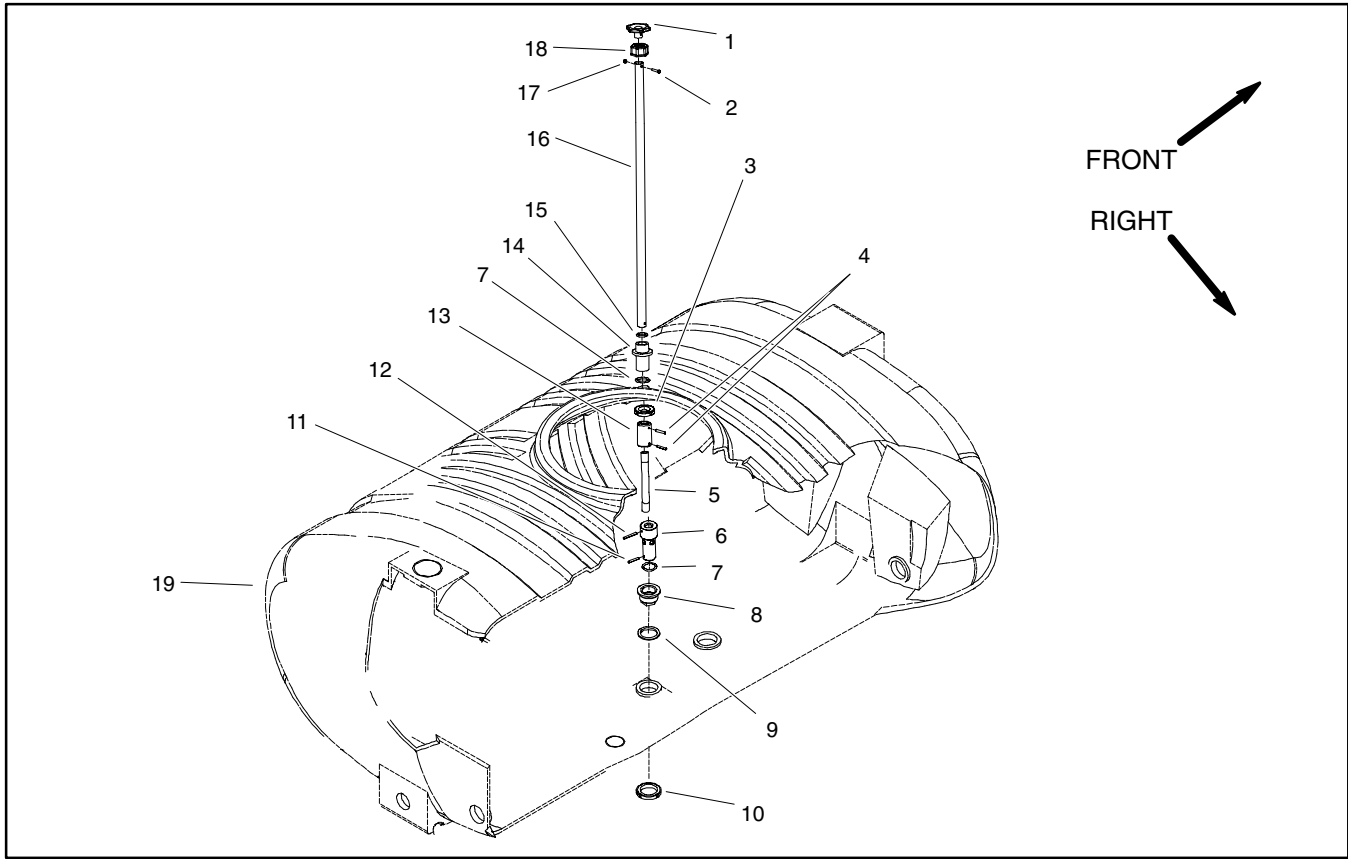

Figure 32

- 1. Tank drain knob
- 2. Bolt
- 3. Ringnut
- 4. Expansion pin
- 5. Flex tube
- 6. Drain screw
- 7. Gasket

- 8. Bulkhead fitting
- 9. Gasket
- 10. Ringnut
- 11. Pin
- 12. Expansion pin
- 13. Tube connector

- 14. Bulkhead
- 15. O-ring
- 16. Drain tube
- 17. Lock nut
- 18. Bulkhead nut
- 19. Spray tank

### Disassembly (Fig. 32)

**IMPORTANT:** Make sure to remove and neutralize chemicals from tank and spray components before disassembly. Wear protective clothing, chemical resistant gloves, and eye protection during repair.

1. Park machine on a level surface, stop engine, engage parking brake, and remove key from the ignition switch.
2. Drain spray tank (see Operator's Manual).
3. Remove bolt and lock nut that secure tank drain knob to drain tube. Slide knob from tube.
4. Loosen bulkhead nut from bulkhead. Slide nut and o-ring from drain tube.
5. Raise tank lid and remove strainer basket to gain access to ringnut (item 7) that secures bulkhead (item 14) to tank. Loosen and remove ringnut from bulkhead. Slide bulkhead from drain tube.
6. Loosen and remove ringnut (item 10) that secures bulkhead fitting (item 8) to bottom of tank.
7. Lift drain tube until bulkhead fitting (item 8) clears bottom of tank. Lower drain tube assembly into tank and remove tube assembly through tank lid opening.
8. Disassemble drain tube using Figure 32 as a guide. Discard all removed o-rings and gaskets.

### Assembly (Fig. 32)

**NOTE:** Coat all o-rings with vegetable oil before installation to reduce the chance of damage during assembly.

1. Assemble drain tube using Figure 32 as a guide. Replace all removed o-rings and gaskets.
2. Check spray tank for leaks.

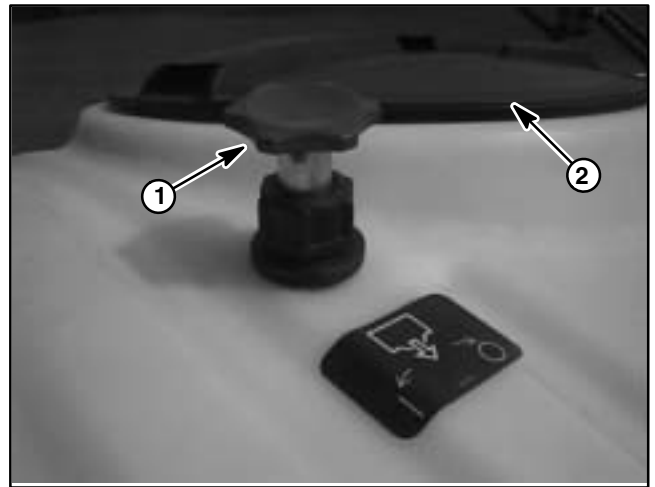

Figure 33

1. Tank drain knob

2. Tank lid

# Tank Drain Valve (Serial Numbers 230000400 and above)

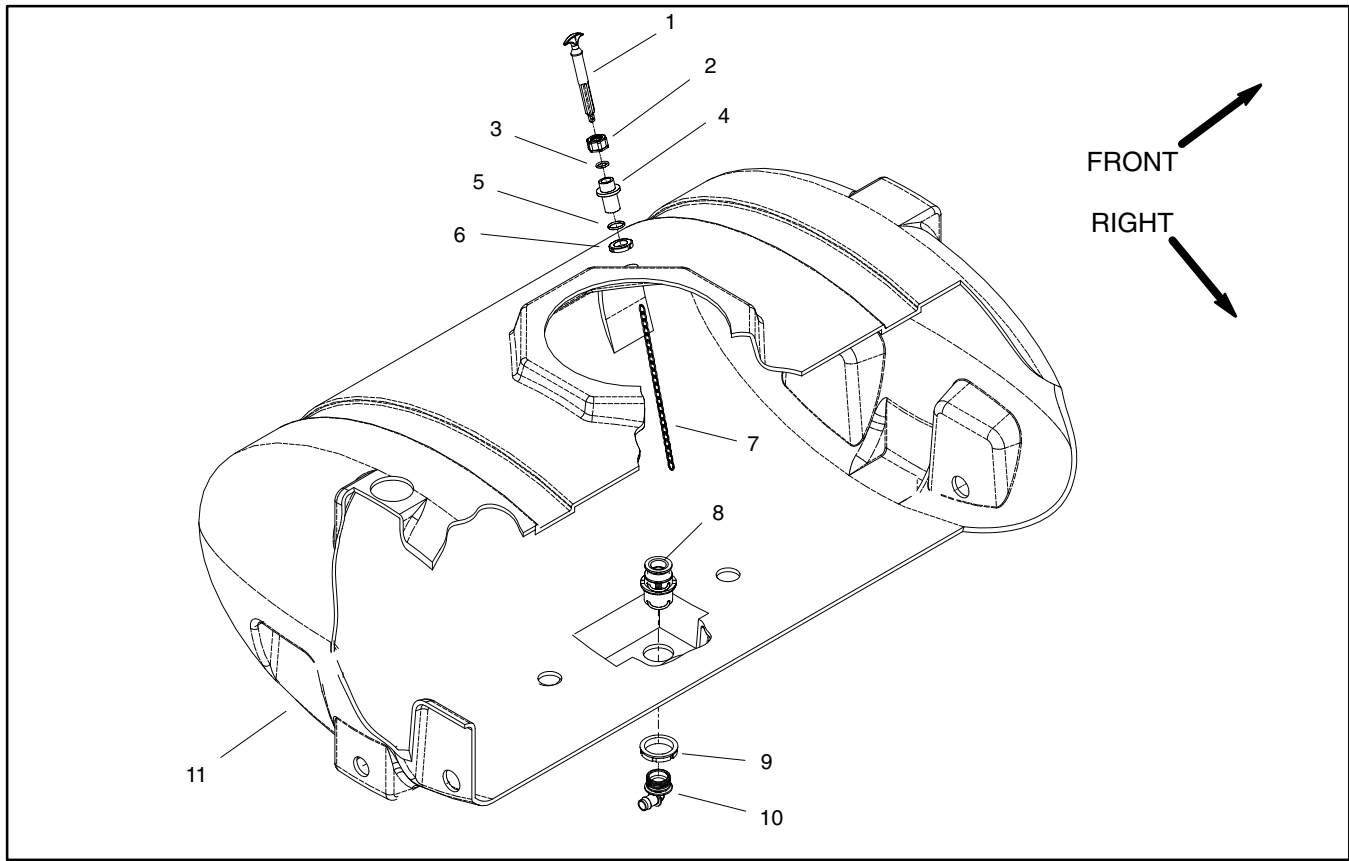

Figure 34

- 1. Drain handle
- 2. Nut
- 3. O-ring
- 4. Bulkhead

- 5. Gasket
- 6. Ringnut
- 7. Chain
- 8. Drain assembly

- 9. Bulkhead
- 10. Hosebarb
- 11. Spray tank

### Disassembly (Fig. 32)

**IMPORTANT:** Make sure to remove and neutralize chemicals from tank and spray components before disassembly. Wear protective clothing, chemical resistant gloves, and eye protection during repair.

1. Park machine on a level surface, stop engine, engage parking brake, and remove key from the ignition switch.

2. Drain spray tank (see Operator's Manual).

3. Raise tank lid and remove strainer basket to gain access to chain (item 7) that connects drain handle (item 1) to plunger in drain assembly (item 8). Disconnect chain from drain handle.

4. If necessary, remove drain handle and bulkhead from tank using Figure 32 as a guide.

5. If necessary, remove drain assembly from tank:

A. Remove fork from drain assembly to allow hosebarb to be removed from drain assembly.

B. Remove bulkhead nut that secures drain assembly to spray tank.

C. Lift drain assembly from bottom of tank.

6. Disassemble drain assembly using Figure 35 as a guide.

7. Discard all removed o-rings and gaskets.

### Assembly (Fig. 32)

**NOTE:** Coat all o-rings with vegetable oil before installation to reduce the chance of damage during assembly.

1. Assemble drain tube using Figures 32 and 35 as guides. Replace all removed o-rings and gaskets.

2. Check spray tank for leaks.

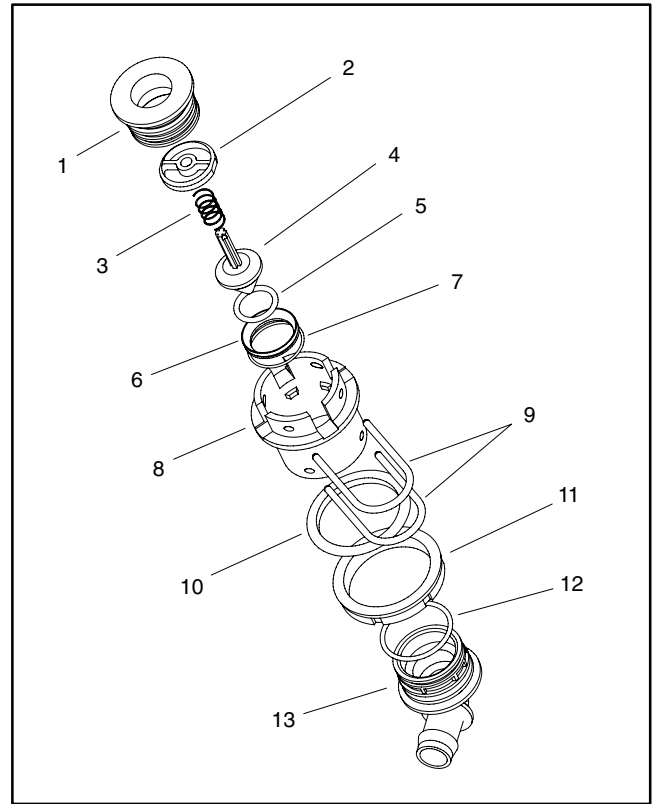

Figure 35

- |                   |                   |
|-------------------|-------------------|
| 1. Adapter        | 8. Drain bulkhead |
| 2. Plunger holder | 9. Fork           |
| 3. Spring         | 10. Gasket        |
| 4. Drain plunger  | 11. Bulkhead nut  |
| 5. O-ring         | 12. O-ring        |
| 6. Drain seat     | 13. Hosebarb      |
| 7. O-ring         |                   |

## Turret Bodies

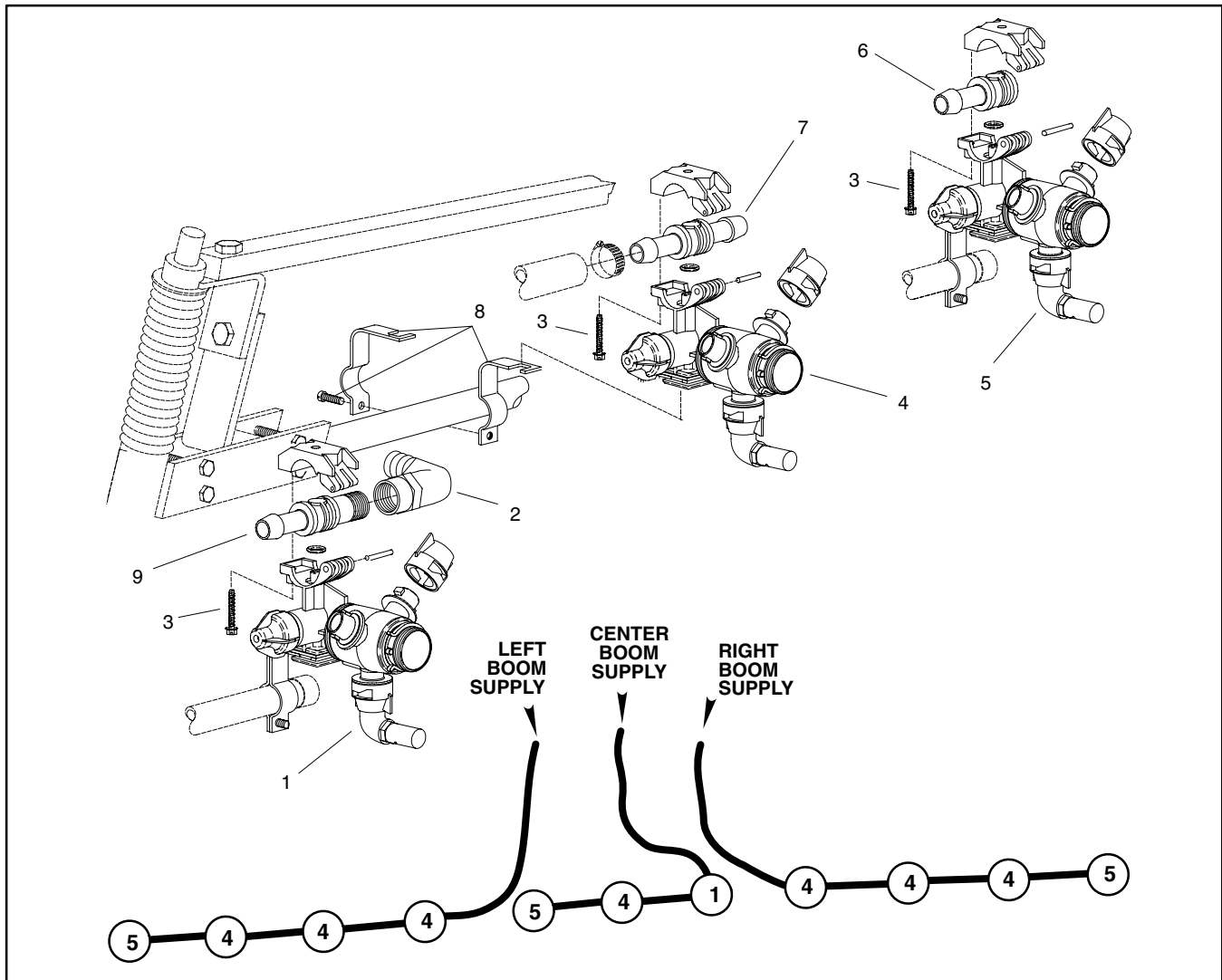

Figure 36

- |                              |                                     |                              |
|------------------------------|-------------------------------------|------------------------------|
| 1. Turret body (w/90° elbow) | 4. Turret body (w/double hose barb) | 7. Double hose barb(7 used)  |
| 2. 90° elbow (1 used)        | 5. Turret body (w/single hose barb) | 8. Turret body clamp         |
| 3. Screw                     | 6. Single hose barb (3 used)        | 9. Hose barb (for 90° elbow) |

### Removal (Fig. 36)

**IMPORTANT: Make sure to remove and neutralize chemicals from spray components before disassembly. Wear protective clothing, chemical resistant gloves, and eye protection during repair.**

1. Park machine on a level surface, stop engine, engage parking brake, and remove key from the ignition switch.
2. Loosen hose clamps and remove supply hose(s) from turret body.
3. Remove screw that secures turret body clamp to spray boom. Separate clamp halves and remove turret body from machine.

### Installation (Fig. 36)

**NOTE:** The type of hose barb on turret body determines turret location on spray boom. Refer to Figure 36 for turret position on booms.

1. Position turret body clamp halves to spray boom and turret body. Slide clamp halves together. Position turret so that spray nozzle and nozzle fan slot are parallel to ground. Tighten clamp screw to secure turret body.
2. Install supply hose(s) to turret body. Tighten hose clamp(s).



## Turret Body Service

### Disassembly (Fig. 37)

**IMPORTANT:** Make sure to remove and neutralize chemicals from spray components before disassembly. Wear protective clothing, chemical resistant gloves, and eye protection during repair.

1. Pull e-clip from body and slide plug with o-ring from body.
2. Disassemble turret body using Figure 37 as a guide.
3. Discard all removed seals, gaskets, o-rings, and diaphragms.

### Assembly (Fig. 37)

**NOTE:** Coat all o-rings with vegetable oil before installation to reduce the chance of damage during assembly.

1. Replace all removed seals, gaskets, o-rings, and diaphragms.

2. Assemble turret body using Figure 37 as a guide.

A. The turret (item 8) end with slightly larger bore and detent grooves needs to be orientated toward detent posts on body (item 4) (Fig. 38).

B. Make sure to align notch on plug (item 10) with groove in body (item 4) as plug is installed.

C. Install e-clip (item 5) into body to secure assembly.

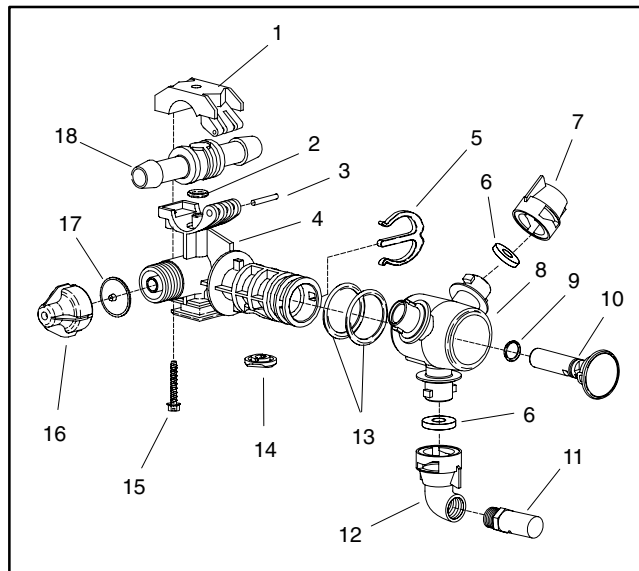

Figure 37

- |                      |                |
|----------------------|----------------|
| 1. Upper clamp       | 10. Plug       |
| 2. O-ring            | 11. Nozzle     |
| 3. Pivot pin         | 12. Nozzle cap |
| 4. Body              | 13. O-ring     |
| 5. E-clip            | 14. Seal       |
| 6. Gasket (3 used)   | 15. Screw      |
| 7. Dust cap (2 used) | 16. End cap    |
| 8. Turret            | 17. Diaphragm  |
| 9. O-ring            | 18. Hose barb  |

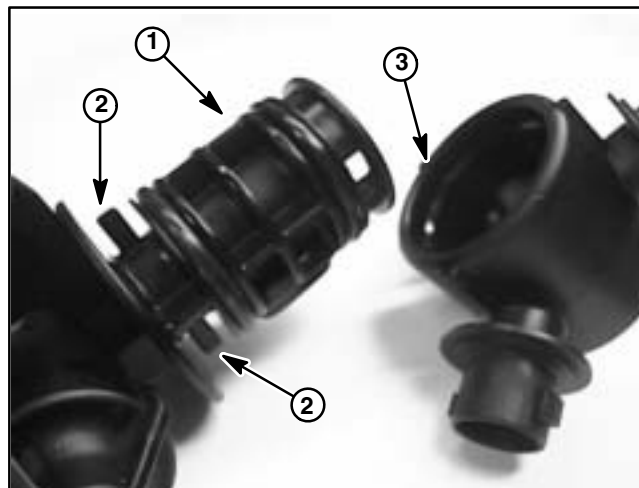

Figure 38

- |                |                  |
|----------------|------------------|
| 1. Body        | 3. Detent groove |
| 2. Detent post |                  |

Spray System

# Boom Frame Breakaway Pivot Assembly

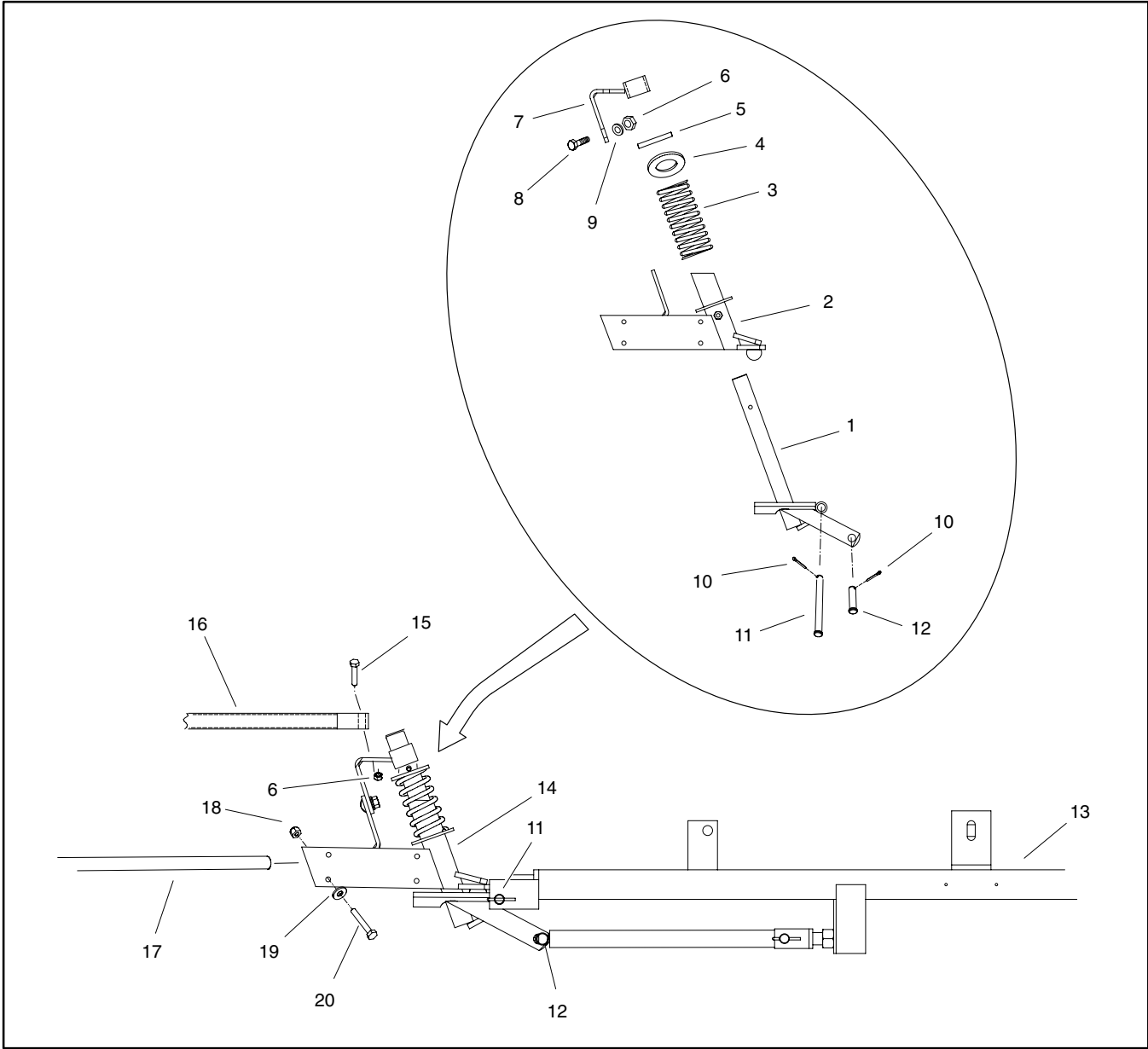

Figure 39

- 1. Hinge
- 2. Breakaway pivot
- 3. Spring
- 4. Washer
- 5. Roll pin
- 6. Hex nut
- 7. Support bracket
- 8. Carriage screw
- 9. Flat washer
- 10. Cotter pin
- 11. Clevis pin
- 12. Clevis pin
- 13. Main boom frame
- 14. Breakaway assembly
- 15. Cap screw
- 16. Boom support
- 17. Boom extension pipe
- 18. Lock nut
- 19. Flat washer
- 20. Cap screw (4 used per side)

### Disassembly (Fig. 39)

1. Park machine on a level surface, lower booms, stop engine, engage parking brake, and remove key from the ignition switch.
2. Support boom to prevent it from falling. Remove cap screw and hex nut that secure boom support to breakaway assembly.
3. Remove hex nut, flat washer, and carriage screw that secure support bracket to breakaway pivot. Slide support bracket from breakaway assembly.

**CAUTION**

**Spring in breakaway pivot is under tension. To prevent possible personal injury, compress spring before removing roll pin. Wear eye protection when removing roll pin.**

4. Compress spring in breakaway assembly slightly. Drive roll pin from hinge (Fig. 41). Remove flat washer and spring from assembly.
5. Complete disassembly as required using Figures 39 and 40 as guides.

### Assembly (Fig. 39)

1. Assemble breakaway pivot using Figures 39 and 40 as guides.
2. Lubricate grease fitting on breakaway pivot after assembly is complete (see Operator's Manual).

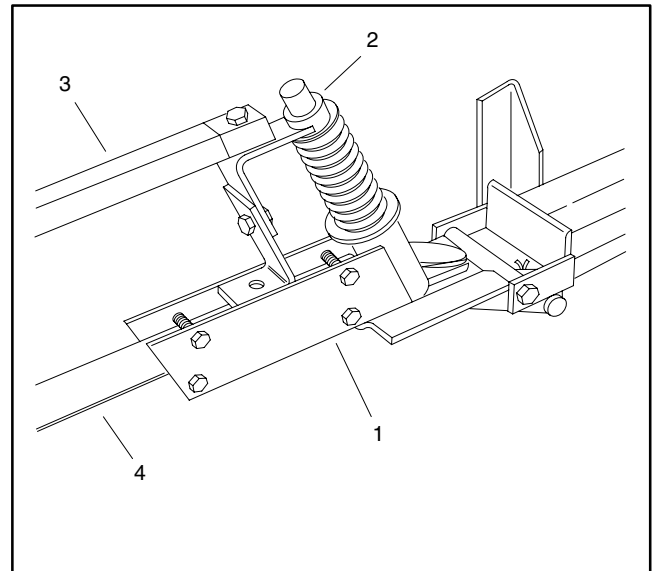

Figure 40

- |                    |                        |
|--------------------|------------------------|
| 1. Breakaway pivot | 3. Boom support        |
| 2. Support bracket | 4. Boom extension pipe |

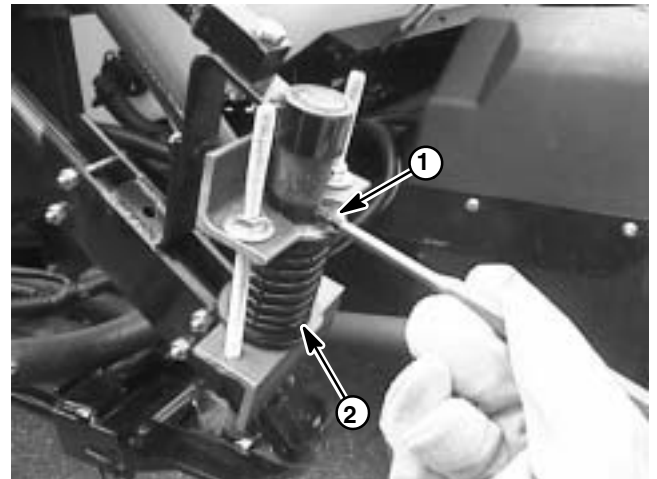

Figure 41

- |             |           |
|-------------|-----------|
| 1. Roll pin | 2. Spring |
|-------------|-----------|

## Pro Control Spray System (Optional)

The Multi Pro 5600 has an optional Pro Control Spray System available. This system includes a computer and flowmeter and is designed to automatically control spray application at varying vehicle speeds. The Operator's Manual for the Pro Control System includes information regarding installation, operation, programming, and maintenance. Refer to your Operator's Manual for information on the Pro Control Spray System.

**NOTE:** When a vehicle is equipped with the optional Pro Control Spray System, the bypass valves on all boom valve motors must be fully closed.

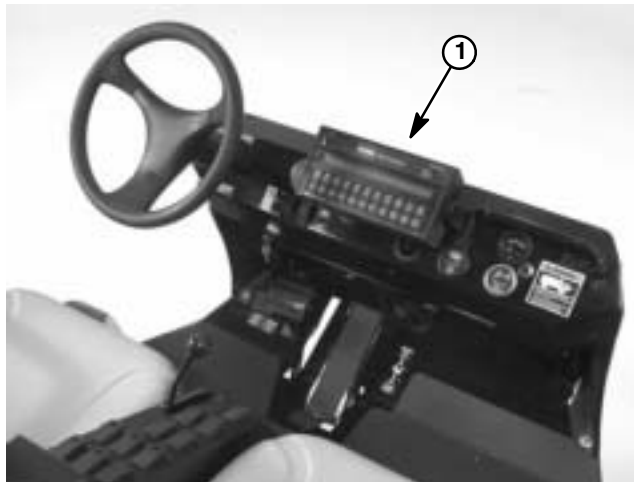

Figure 42

1. Pro Control computer

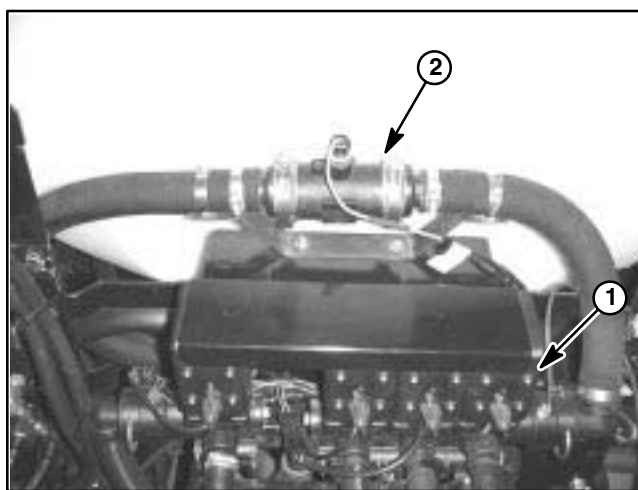

Figure 43

1. Spray control assembly
2. Pro Control flowmeter

This page is intentionally blank.

## Boom Actuator (Optional)

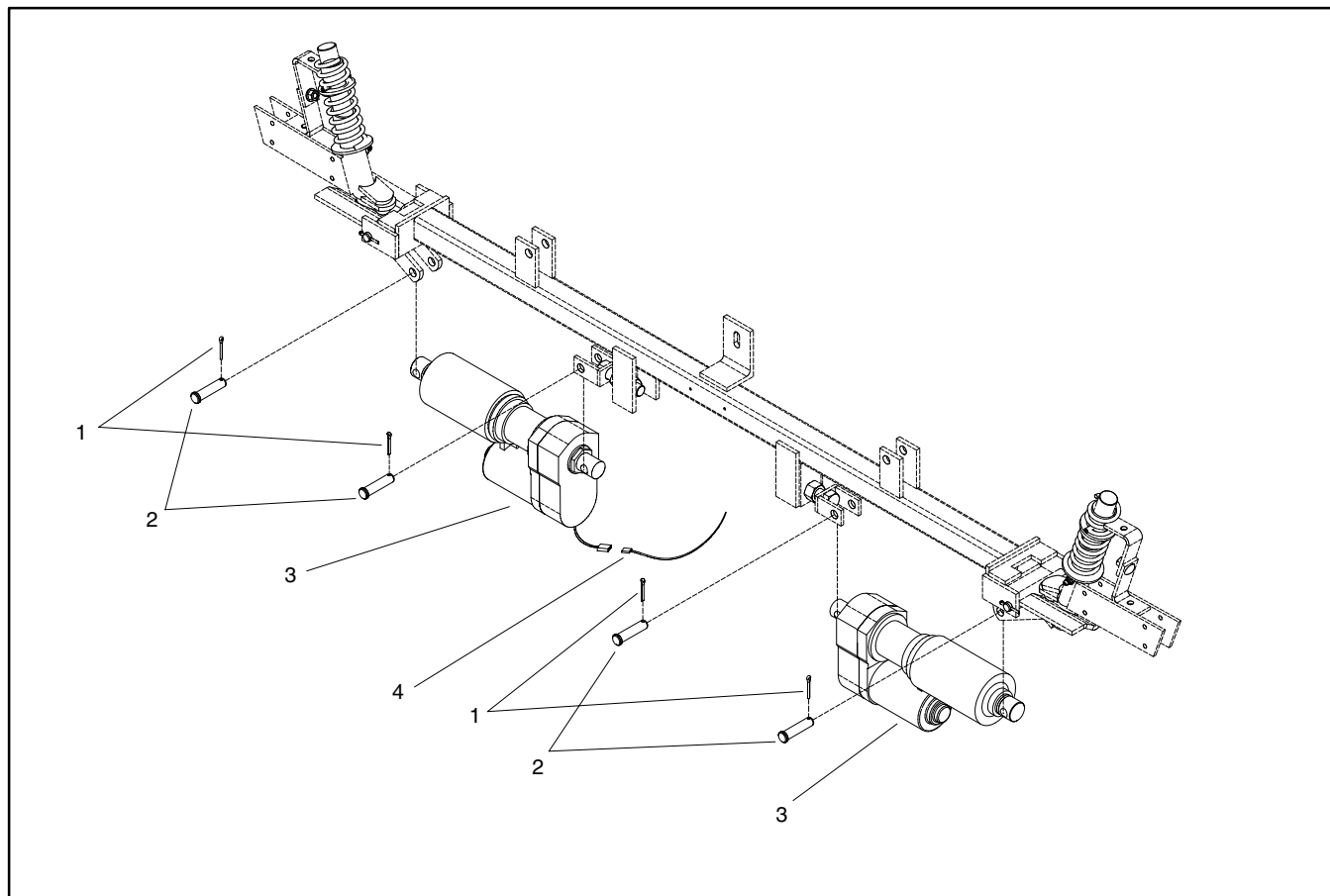

Figure 44

- 1. Cotter pin
- 2. Clevis pin

- 3. Boom actuator

- 4. Wire harness

### Removal (Fig 44)

1. Park machine on a level surface, lower booms, stop engine, engage parking brake, and remove key from the ignition switch.
2. Label actuator electrical leads to ease reassembly. Unplug boom actuator connector wires from machine harness.
3. Support boom to prevent it from falling. Remove cotter pins and clevis pins that attach boom actuator to center and side boom.
4. Pull actuator from machine.

### Installation (Fig 44)

1. Position actuator to clevis attachment points on center and side booms.
2. Install clevis pins and cotter pins to secure actuator to boom assembly.
3. Plug actuator connector wires into machine harness. Make sure that operator switches engage correct actuator.

### Adjustment

1. Loosen end nut that secures adjustable clevis to boom frame (Fig. 45). Position jam nut as close as possible to adjustable clevis. Tighten end nut to secure clevis.

2. Fully raise side boom with the boom actuator. The boom actuator should fully extend and ratchet.

3. With the boom actuator at full extension, the break-away pivot gusset should just touch the center boom frame slot (Fig. 46).

4. If needed, loosen end nut that secures adjustable clevis and readjust jam nut on clevis to allow correct boom actuator extension. Tighten end nut to secure clevis adjustment.

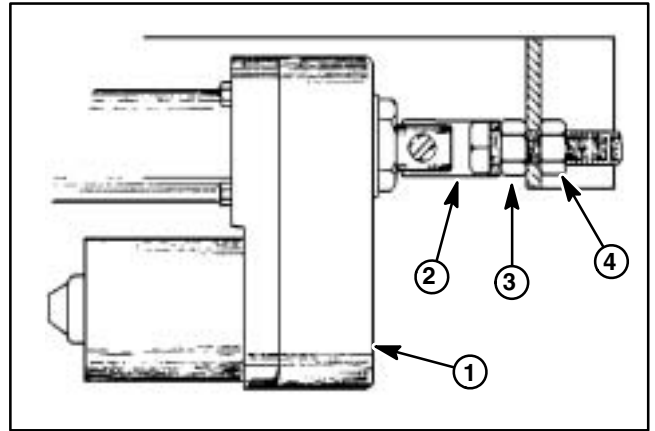

Figure 45

- |                      |            |
|----------------------|------------|
| 1. Boom actuator     | 3. Jam nut |
| 2. Adjustable clevis | 4. End nut |

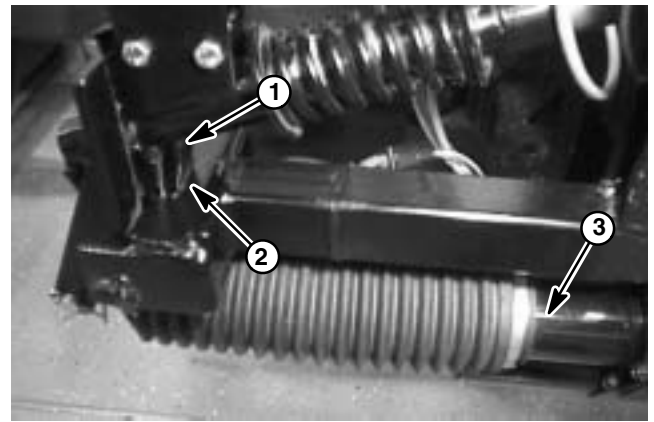

Figure 46

- |                           |                  |
|---------------------------|------------------|
| 1. Breakaway pivot gusset | 3. Boom actuator |
| 2. Boom frame slot        |                  |

## Boom Actuator Service

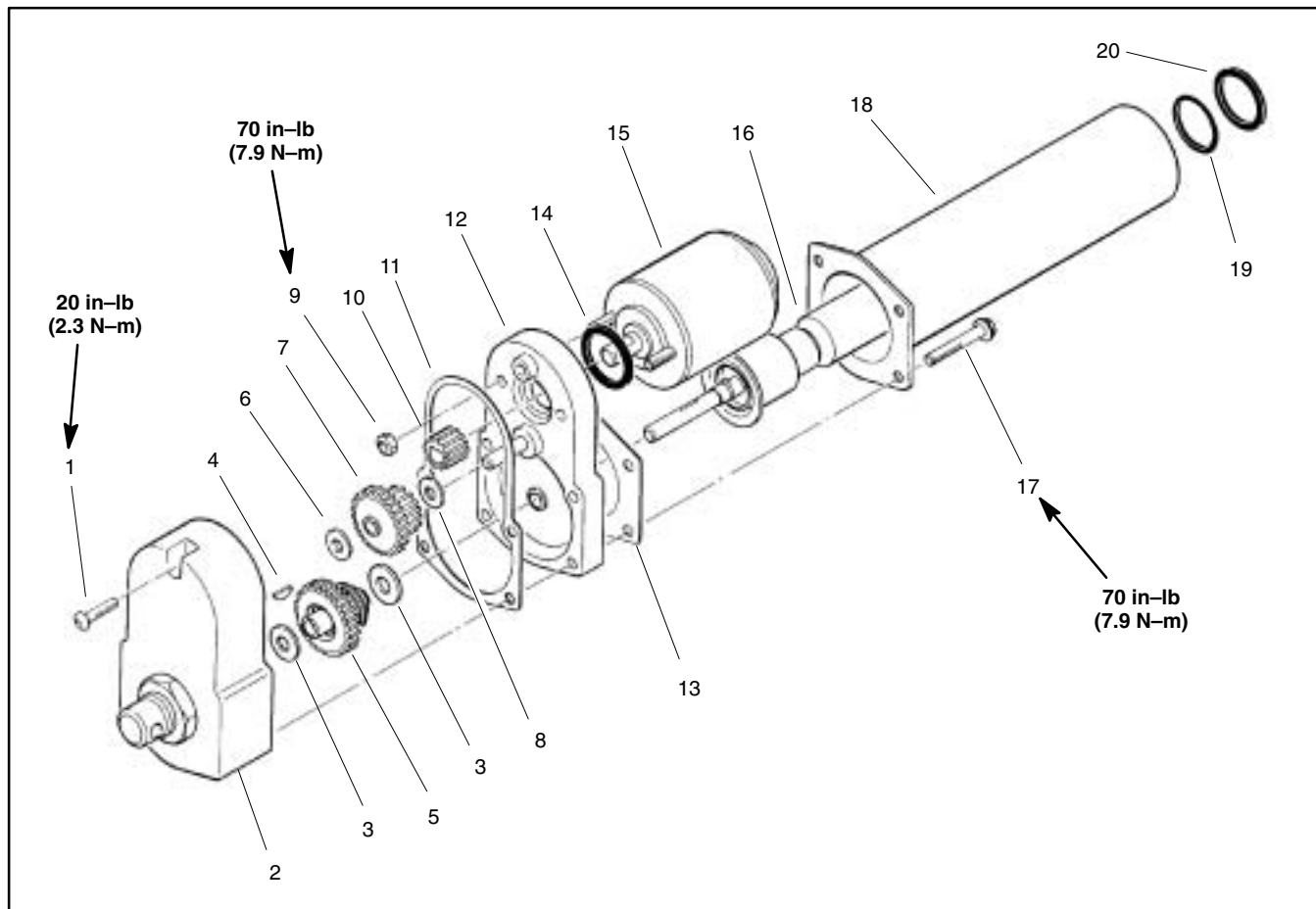

Figure 47

- 1. Screw
- 2. Rear housing
- 3. Washer
- 4. Woodruff key
- 5. Clutch
- 6. Thin washer
- 7. Intermediate gear

- 8. Thick washer
- 9. Hex nut (2 used)
- 10. Motor gear
- 11. Housing gasket
- 12. Front housing
- 13. Cover tube gasket
- 14. Motor seal

- 15. Motor assembly
- 16. Ball screw and brake assembly
- 17. Washer head screw (4 used)
- 18. Cover tube
- 19. O-ring
- 20. O-ring



### Disassembly (Fig. 47)

1. Remove four (4) washer head screws that secure cover tube. Remove one (1) screw (item 1) that retains rear housing. Slide rear housing and housing gasket from assembly.
2. Slide thin washer, intermediate gear, and thick washer from front housing support pin.
3. In order, remove washer, clutch, woodruff key, and second washer from ball screw shaft.
4. Pull cover tube from front housing. Remove cover tube gasket.
5. Loosen and remove two (2) hex nuts that secure motor to front housing. Slide motor, motor gear, and motor seal from front housing.
6. Remove ball screw and brake assembly from front housing.
7. Clean actuator components. Replace worn or damaged parts.
8. Discard and replace all removed gaskets and o-rings.

### Assembly (Fig. 47)

1. Position ball screw and brake assembly to front housing. Take care to not disturb brake components.
2. Slide motor, motor gear, and motor seal to front housing. Secure motor with two (2) hex nuts. Torque nuts to 70 in-lb (7.9 N-m).
3. Install new o-rings into rear of cover tube. Slide cover tube gasket and cover tube over ball screw.
4. Place washer on ball screw shaft. Position woodruff key and then slide clutch and second washer onto shaft.
5. Place thick washer, intermediate gear, and thin washer onto front housing support pin. Make sure that intermediate gear engages both motor gear and clutch.
6. Position housing gasket to front housing. Slide rear housing over gears.
7. Secure rear housing:
  - A. Thread one (1) screw (item 1) through rear housing and into front housing.
  - B. Install four (4) washer head screws through cover tube.
  - C. Torque screw (item 1) to 20 in-lb (2.3 N-m). Torque four washer head screws to 70 in-lb (7.9 N-m).

This page is intentionally blank.



## Table of Contents

SPECIFICATIONS .....	2
SERVICE AND REPAIRS .....	3
Tie Rod Ends .....	3
Front Wheels and Hubs .....	4
Spindles .....	6
Front Suspension .....	8
Brake Assembly .....	10
Brake Inspection and Repair .....	12
Brake Cables .....	13
Planetary Wheel Drive Assembly .....	14
Planetary Wheel Drive Service .....	16

# Specifications

Item	Description
Front Tire Pressure (23 x 10.5 – 12, 4 ply, tubeless)	18 PSI (1.24 bar) Maximum
Rear Tire Pressure (26.5 x 14 – 12, 4 ply, tubeless)	18 PSI (1.24 bar) Maximum
Front Wheel Lug Nut Torque	65 ft-lb (88 N-m)
Rear Wheel Lug Nut Torque	90 ft-lb (122 N-m)
Planetary, Brake Assembly and Wheel Motor Mounting Screw Torque	60 ft-lb (81 N-m)
Front Wheel Toe-In	1/8 to 1/4 inch (3.2 to 6.4 mm)
Planetary Gear Drive Lubricant Planetary Gear Lubricant Capacity (each wheel)	SAE 85W-140 wt. Gear Lube 16 fl oz (.47 l)

# Service and Repairs

## Tie Rod Ends

### Removal (Fig. 1)

1. Loosen jam nut on tie rod end. **Note:** Left side tie rod end has left hand threads.
2. Remove cotter pin and castle nut that secure tie rod end to spindle.
3. Use a suitable puller to separate tie rod end from spindle.
4. When removing tie rod end from tie rod, count the number of revolutions it takes to remove so new tie rod end can be installed with minimal change to front wheel toe-in.

### Installation (Fig. 1)

1. Install dust boot on new tie rod end.
2. Thread tie rod end into tie rod the same number of revolutions as the old tie rod end took to remove.
3. Install grease fitting into tie rod end.
4. Insert tie rod end shaft into spindle and secure with castle nut. Torque castle nut from 20 to 25 ft-lb (27 to 34 N-m). If necessary, nut can be tightened slightly further to align cotter pin position in spindle and nut. Install cotter pin.
5. Grease tie rod end (see Operator's Manual).
6. Check front wheel toe-in and adjust if needed (see Operator's Manual).

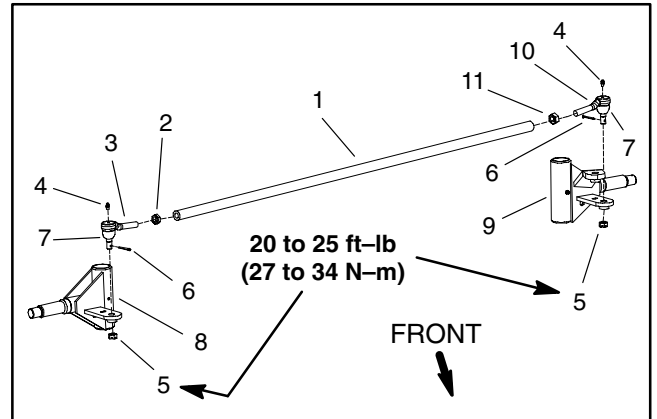

Figure 1

- |                        |                         |
|------------------------|-------------------------|
| 1. Tie rod             | 7. Dust boot            |
| 2. Jam nut (RH thread) | 8. RH spindle           |
| 3. RH tie rod end      | 9. LH spindle           |
| 4. Grease fitting      | 10. LH tie rod end      |
| 5. Castle nut          | 11. Jam nut (LH thread) |
| 6. Cotter pin          |                         |

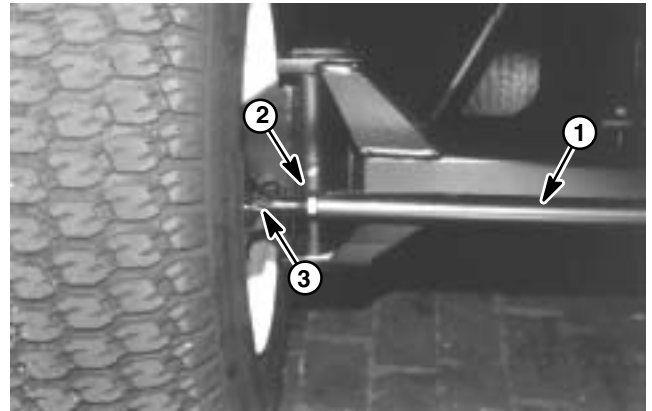

Figure 2

- |            |                |
|------------|----------------|
| 1. Tie rod | 3. Tie rod end |
| 2. Jam nut |                |

# Front Wheels and Hubs

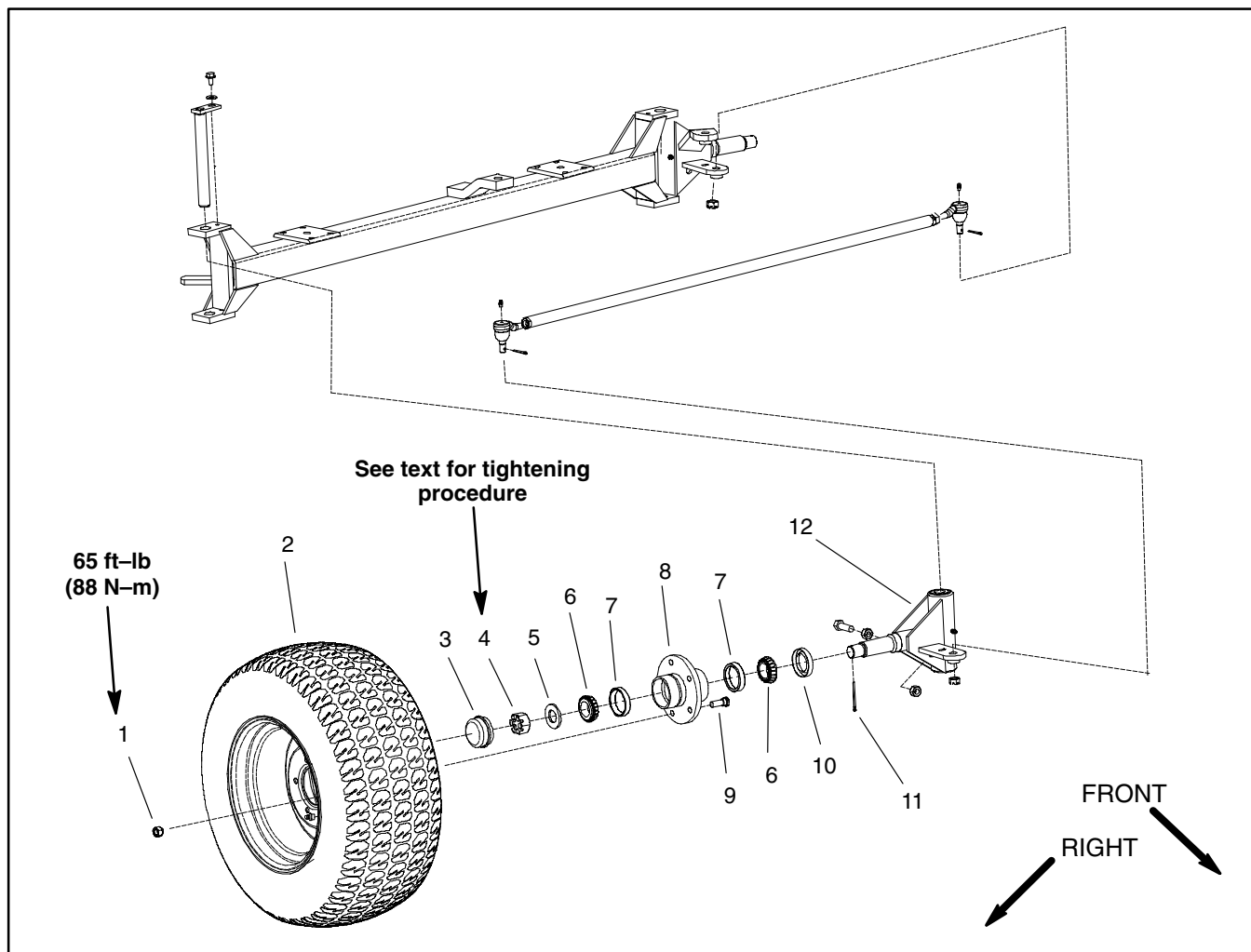



Figure 3

- |                               |                       |                                  |
|-------------------------------|-----------------------|----------------------------------|
| 1. Lug nut (5 used per wheel) | 5. Washer             | 9. Wheel stud (5 used per wheel) |
| 2. Wheel and tire assembly    | 6. Wheel bearing cone | 10. Seal                         |
| 3. Dust cap                   | 7. Wheel bearing cup  | 11. Cotter pin                   |
| 4. Slotted hex nut            | 8. Wheel hub          | 12. Front spindle (RH shown)     |

### Removal (Fig. 3)

1. Park machine on a level surface, stop engine, engage parking brake, and remove key from the ignition switch.

**CAUTION**

**When changing tires or performing other service, use correct blocks, hoists, and jacks. Make sure machine is parked on a solid, level surface such as a concrete floor. Prior to raising machine, remove any attachments that may interfere with the safe and proper raising of the machine. Always chock or block wheels. Use jack stands or solid wood blocks to support the raised machine. If the machine is not properly supported by blocks or jack stands, the machine may move or fall, which may result in personal injury.**

2. Jack front wheel off the ground (see Jacking Instructions in Operator's Manual). Chock front and rear of other wheels.
3. Remove lug nuts and front wheel assembly.
4. Carefully pry dust cap from wheel hub.
5. Remove cotter pin from front spindle.
6. Remove slotted hex nut and washer that secures wheel hub to spindle. Slide wheel hub with bearings from spindle.
7. If required, disassemble wheel hub:
  - A. Pull seal out of the wheel hub.
  - B. Remove bearings from both sides of wheel hub. Clean bearings in solvent. Clean inside of the hub.
  - C. Inspect wheel bearings. Check the bearings and cups for wear, pitting, or other noticeable damage. Replace worn or damaged parts.

### Installation (Fig. 3)

1. Clean all parts thoroughly before reassembly.
2. If wheel bearings were removed from wheel hub, assemble wheel hub:
  - A. If bearing cups were removed from the wheel hub, press inner and outer cups into the hub until they seat against the hub shoulder.
  - B. Pack both bearings with grease. Install greased inner bearing into the cup on inboard side of the wheel hub.
  - C. Fill hub approximately 50% full of grease.  
**IMPORTANT: The lip seal must be pressed in so it is flush with the end of the hub. The lip of the seal must face the bearing.**
  - D. Lubricate the inside of the new lip seal and press it into the wheel hub.
3. Install the wheel hub onto the spindle shaft taking care to not damage seal.
4. Install greased outer bearing cone, washer, and slotted hex nut onto spindle shaft.
5. Rotate the wheel hub by hand and torque the slotted hex nut from 75 to 180 in-lb (8.5 to 20.3 N-m) to seat bearing. Loosen nut until it is away from washer and hub has end play. Finally, tighten slotted hex nut from 15 to 20 in-lbs (1.7 to 2.3 N-m) while rotating hub.
6. Install cotter pin through spindle shaft hole. Install dust cap to hub.

**WARNING**

**Failure to maintain proper lug nut torque could result in failure or loss of wheel and may result in personal injury.**

7. Install wheel assembly with valve stem facing out and secure with lug nuts. Torque lug nuts evenly in a crossing pattern to 65 ft-lb (88 N-m).
8. Lower machine to ground.

# Spindles

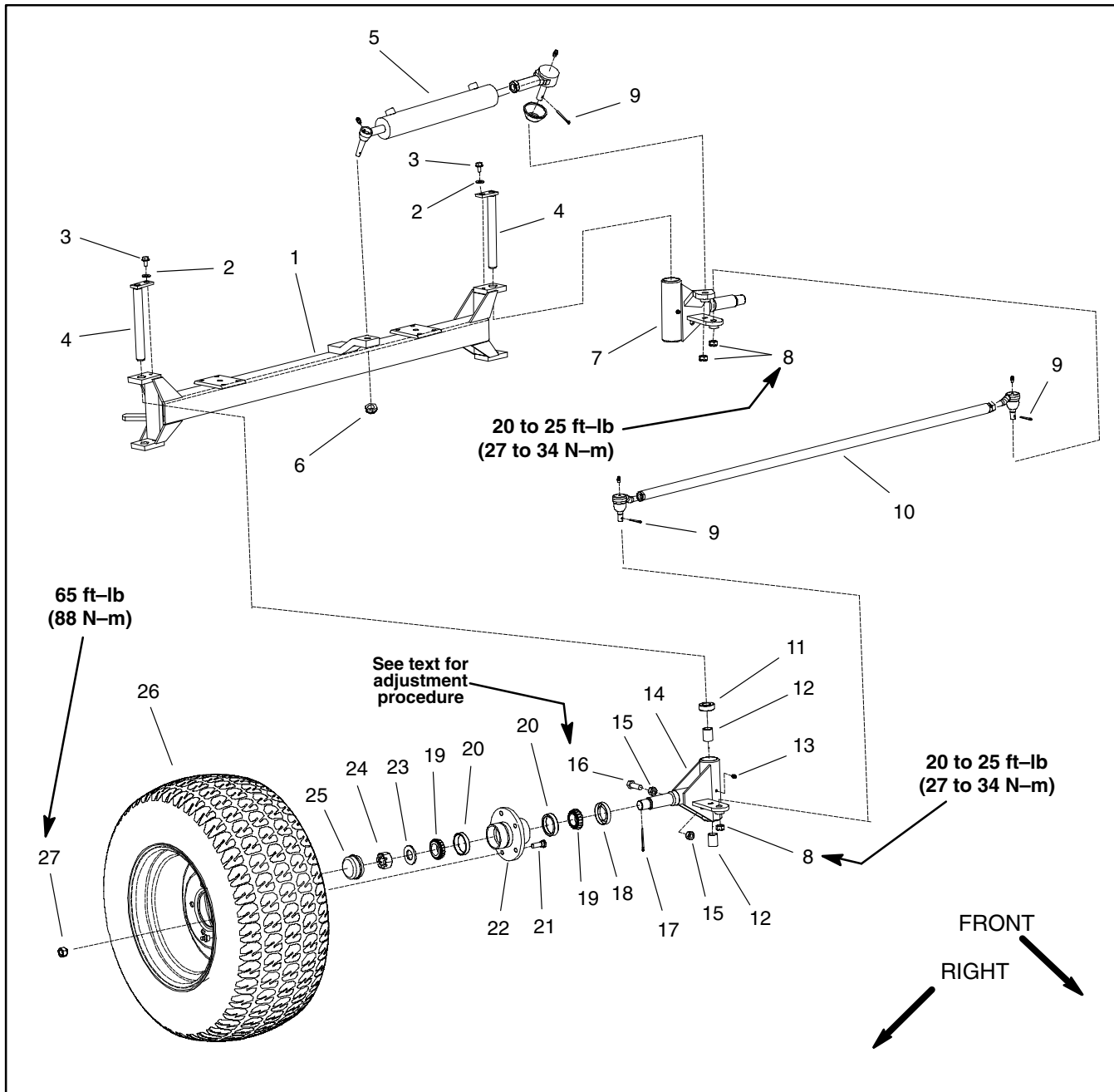



Figure 4

- |   |  |   |
|---|--|---|
| <ul style="list-style-type: none"> <li>1. Front axle</li> <li>2. Flat washer</li> <li>3. Washer head screw</li> <li>4. King pin</li> <li>5. Hydraulic steering cylinder</li> <li>6. Lock nut</li> <li>7. LH spindle assembly</li> <li>8. Castle nut</li> <li>9. Cotter pin</li> </ul> | <ul style="list-style-type: none"> <li>10. Tie rod assembly</li> <li>11. Thrust bearing</li> <li>12. Bushing</li> <li>13. Grease fitting</li> <li>14. RH spindle</li> <li>15. Hex nut</li> <li>16. Steering stop bolt</li> <li>17. Cotter pin</li> <li>18. Oil seal</li> </ul> | <ul style="list-style-type: none"> <li>19. Bearing cone</li> <li>20. Bearing cup</li> <li>21. Wheel stud (5 used per wheel)</li> <li>22. Wheel hub</li> <li>23. Flat washer</li> <li>24. Slotted hex nut</li> <li>25. Dust cap</li> <li>26. Wheel assembly</li> <li>27. Lug nut (5 used per wheel)</li> </ul> |
|---|--|---|



## Disassembly (Fig. 4)

1. Park machine on a level surface, stop engine, engage parking brake, and remove key from the ignition switch.

	<b>CAUTION</b>
<p><b>When changing attachments, tires, or performing other service, use correct blocks, hoists, and jacks. Make sure machine is parked on a solid, level surface such as a concrete floor. Prior to raising machine, remove any attachments that may interfere with the safe and proper raising of the machine. Always chock or block wheels. Use jack stands or solid wood blocks to support the raised machine. If the machine is not properly supported by blocks or jack stands, the machine may move or fall, which may result in personal injury.</b></p>	

2. Jack front of machine off ground (see Jacking Instructions in Operator's Manual).

3. Remove front wheel assembly and wheel hub from machine (see Front Wheels and Hubs in this section).

4. Remove tie rod end from spindle (see Tie Rod Ends in this section).

5. If left side spindle is being removed, separate hydraulic steering cylinder from spindle (see Steering Cylinder in Service and Repairs Section of Chapter 4 – Hydraulic System).

6. Remove washer head screw and flat washer that secure king pin to front axle.

7. Support spindle assembly to prevent it from falling during disassembly. Slide king pin from front axle and spindle. Remove spindle from front axle.

8. Remove thrust bearing from top of spindle.

9. If needed, remove bushings and steering stop bolt from spindle.

## Assembly (Fig. 4)

1. If removed, install bushings and steering stop bolt into spindle.

2. Place thrust bearing in top of spindle. Position spindle to front axle. Slide king pin into front axle and spindle.

3. Install washer head screw and flat washer to secure king pin to front axle.

4. If left side spindle was removed, attach hydraulic steering cylinder to spindle (see Steering Cylinder in Service and Repairs Section of Chapter 4 – Hydraulic System).

5. Secure tie rod end to spindle (see Tie Rod End in this section).

	<b>WARNING</b>
<p><b>Failure to maintain proper lug nut torque could result in failure or loss of wheel and may result in personal injury.</b></p>	

6. Install wheel with valve stem facing out and secure with lug nuts. Torque lug nuts evenly in a crossing pattern to 65 ft–lb (88 N–m).

7. Lubricate grease fittings on front axle assembly (see Operator's Manual).

8. Lower machine to ground.

9. Check and adjust front wheel toe-in (see Operator's Manual).

10. Adjust steering stop bolt on each spindle so that at full turn, there is a 1/16" (1.6 mm) gap between the tie rod and front axle.

11. After assembly is complete, make sure that steering components do not contact hoses and/or wires.

# Front Suspension

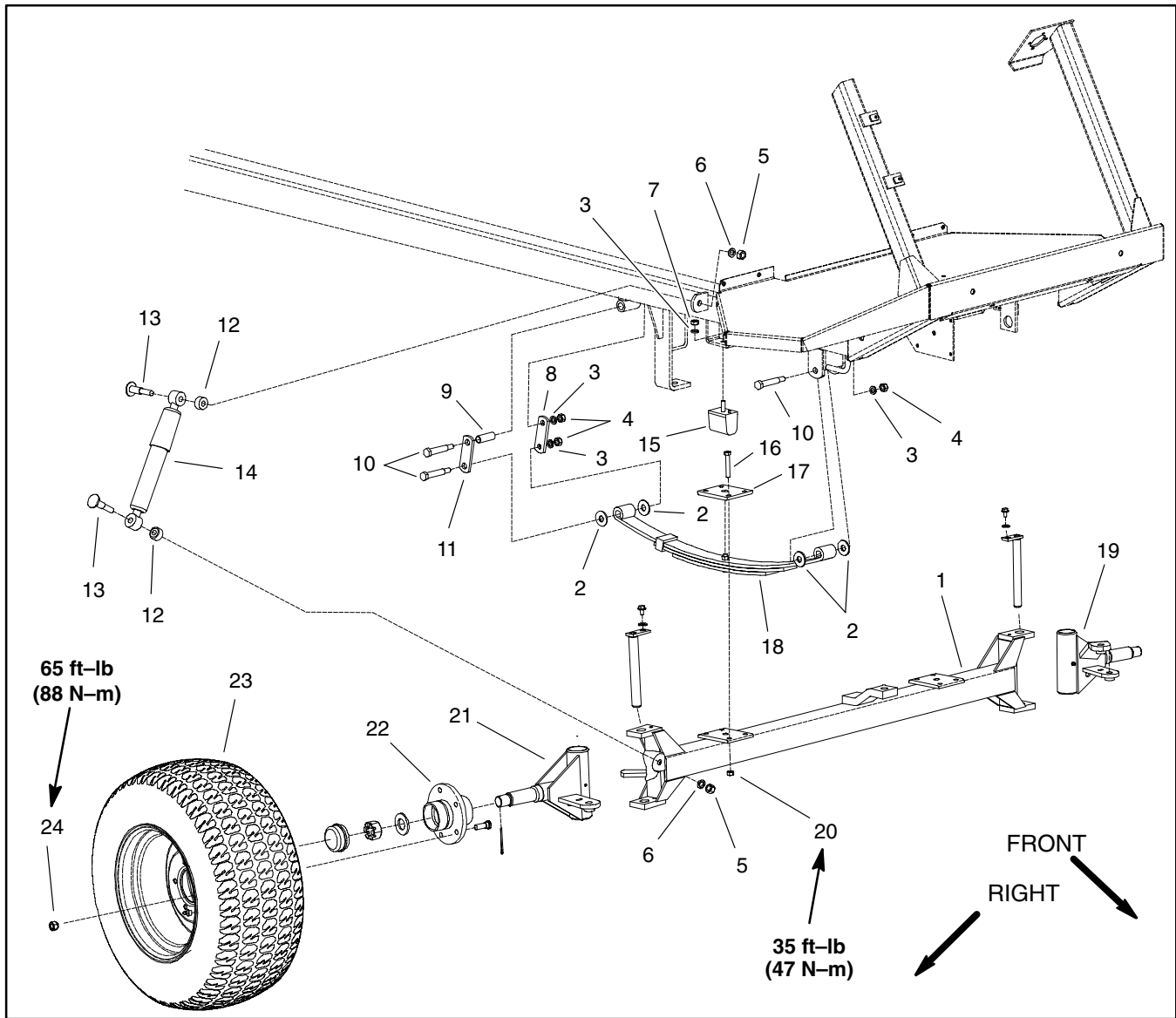



Figure 5

- |                   |                                   |                                  |
|-------------------|-----------------------------------|----------------------------------|
| 1. Front axle     | 9. Shackle bushing                | 17. Spring plate                 |
| 2. Flat washer    | 10. Shoulder bolt                 | 18. Leaf spring                  |
| 3. Lock washer    | 11. Outside shackle               | 19. LH spindle assembly          |
| 4. Hex nut        | 12. Spacer                        | 20. Lock nut (4 used per spring) |
| 5. Hex nut        | 13. Shoulder bolt                 | 21. RH spindle assembly          |
| 6. Lock washer    | 14. Shock absorber                | 22. Hub assembly                 |
| 7. Hex nut        | 15. Axle bumper                   | 23. Wheel assembly               |
| 8. Inside shackle | 16. Cap screw (4 used per spring) | 24. Lug nut (5 used per wheel)   |

## Disassembly (Fig. 5)

1. Park machine on a level surface, stop engine, engage parking brake, and remove key.

 <b>CAUTION</b>
<p><b>When changing attachments, tires, or performing other service, use correct blocks, hoists, and jacks. Make sure machine is parked on a solid, level surface such as a concrete floor. Prior to raising machine, remove any attachments that may interfere with the safe and proper raising of the machine. Always chock or block wheels. Use jack stands or solid wood blocks to support the raised machine. If the machine is not properly supported by blocks or jack stands, the machine may move or fall, which may result in personal injury.</b></p>

2. Jack front of machine off ground (see Jacking Instructions in Operator's Manual). Support machine to allow front suspension to hang freely from machine.

3. Remove front wheel assembly (see Front Wheels and Hubs).

4. Disassemble front suspension as needed using Figure 5 as a guide.

A. If wheel hub requires removal, see Front Wheels and Hubs Removal in this section. If spindle requires removal, see Spindles in this section.

B. When removing leaf springs, support axle to prevent it from falling. Loosen fasteners that secure springs to frame attachment points. Loosen and remove cap screws and locknuts that secure spring plate. Remove shackles, bushings, shoulder bolts, lock washers and hex nuts from spring and frame. Remove leaf springs from machine.

C. If front axle removal is required, remove steering cylinder from axle (see Steering Cylinder in Service and Repair Section of Chapter 4 – Hydraulic System).

## Assembly (Fig. 5)

1. Assemble front suspension using Figure 5 as a guide.

A. When installing suspension components, loosely install all fasteners before tightening any of the fasteners.

B. If wheel hub was removed, see Front Wheels and Hubs Installation in this section. If spindle was removed, see Spindles in this section.

**NOTE:** When installing leaf springs, make sure front axle and spring plate are centered on the screw head and nut that fasten spring leaves.

**IMPORTANT:** If leaf spring replacement is needed, always replace both springs for proper vehicle performance.

C. To install leaf springs, attach springs to frame with shackles, bushings, shoulder bolts, lock washers and hex nuts without tightening fasteners. Install spring plate to top of spring assembly with curved edge toward spring. Install and tighten cap screws and lock nuts in a crossing pattern until spring plate, leaf spring and axle contact. Fully tighten fasteners that secure springs to frame. Torque lock nuts that secure spring plate 35 ft-lb (47 N-m) using a crossing pattern.

D. When installing shock absorbers, make sure that spacer is positioned between shock and frame attachment point.

 <b>WARNING</b>
<p><b>Failure to maintain proper lug nut torque could result in failure or loss of wheel and may result in personal injury.</b></p>

2. Install wheel with valve stem facing out and secure with lug nuts. Torque lug nuts evenly in a crossing pattern to 65 ft-lb (88 N-m).

3. Lower machine to ground.

4. Lubricate suspension grease fittings (see Operator's Manual).

5. Check front wheel toe-in and adjust if necessary (see Operator's Manual).

6. Check front suspension and steering operation. Make sure that components do not contact hoses and/or wires.

## Brake Assembly

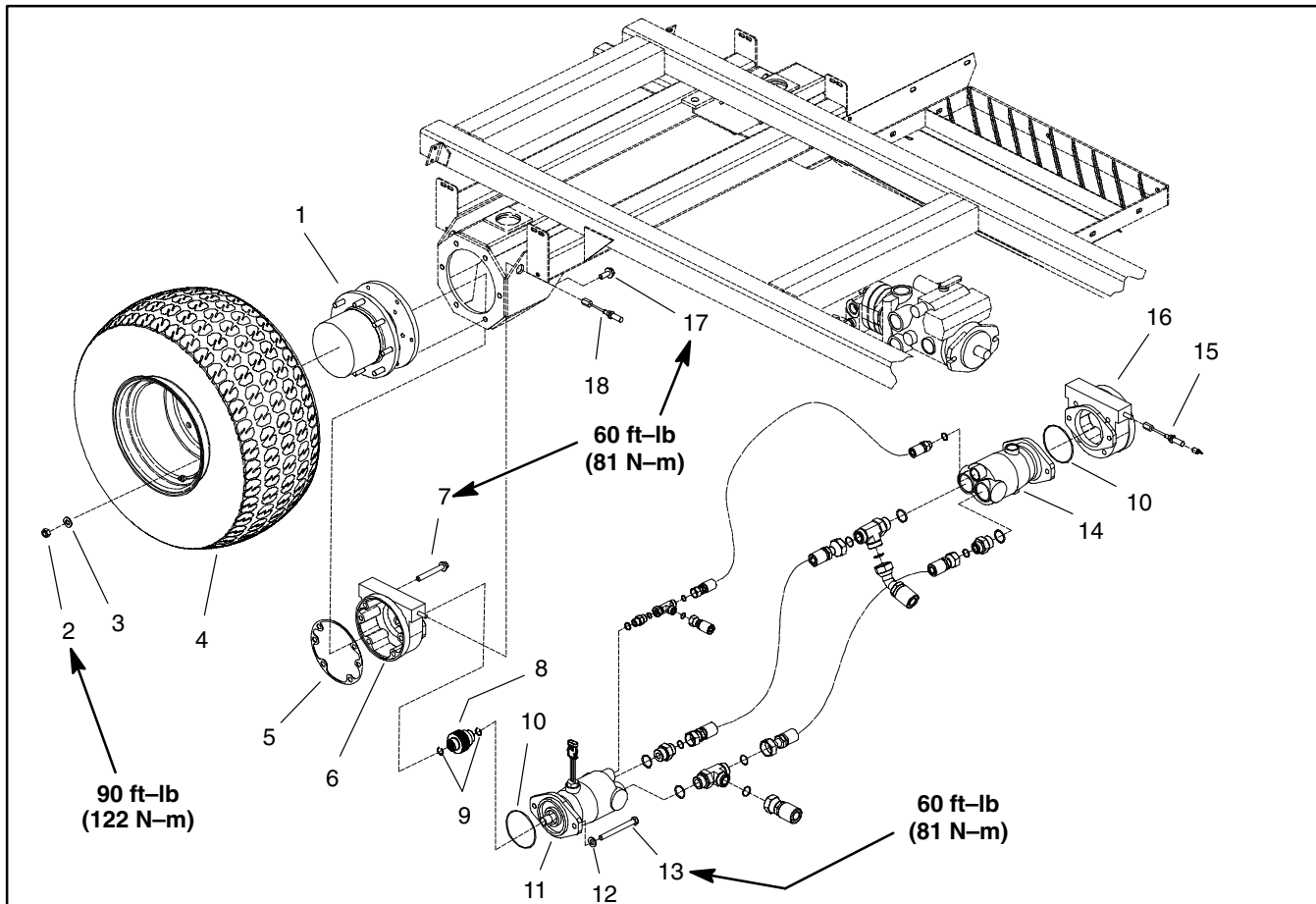

Figure 6

- |                                   |   |   |
|-----------------------------------|---|---|
| 1. Planetary assembly             | 7. Flange head screw (4 used per brake) | 13. Cap screw (2 used per motor)        |
| 2. Lock nut (8 used per wheel)    | 8. Splined brake shaft                  | 14. LH wheel motor                      |
| 3. Flat washer (8 used per wheel) | 9. Retaining ring                       | 15. LH brake cable                      |
| 4. Tire and wheel assembly        | 10. O-ring                              | 16. LH brake assembly                   |
| 5. Gasket                         | 11. RH wheel motor                      | 17. Flange head screw (6 used per side) |
| 6. RH brake assembly              | 12. Flat washer (2 used per motor)      | 18. RH brake cable                      |

### Removal (Fig. 6)

1. Park machine on a level surface, stop engine, engage parking brake, and remove key from the ignition switch.
2. Drain oil from planetary wheel drive/brake assembly (see Operator's Manual).



## CAUTION

When changing attachments, tires, or performing other service, use correct blocks, hoists, and jacks. Make sure machine is parked on a solid, level surface such as a concrete floor. Prior to raising machine, remove any attachments that may interfere with the safe and proper raising of the machine. Always chock or block wheels. Use jack stands or solid wood blocks to support the raised machine. If the machine is not properly supported by blocks or jack stands, the machine may move or fall, which may result in personal injury.

3. Chock front wheels and jack up rear of machine (see Jacking Instructions in Operator's Manual). Support machine with jack stands or solid wood blocks.

4. Remove rear wheel assembly.

5. Remove hydraulic wheel motor (see Rear Wheel Motors in Service and Repairs section of Chapter 4 – Hydraulic System).

6. Disconnect brake cable from pull rod on brake.

**NOTE:** Be careful not to drop splined brake shaft as brake assembly is removed.

7. Support brake assembly and remove four (4) flange head screws that secure brake assembly to planetary assembly. Remove brake assembly from machine.

8. Locate and remove splined brake shaft.

9. Complete brake inspection and repair.

### Installation (Fig. 6)

**NOTE:** The stepped end of the splined brake shaft must be aligned toward the hydraulic wheel motor (Fig. 7).

1. Install splined brake shaft into brake assembly. Make sure that splines engage rotating discs in brake assembly.

2. Make sure that gasket surfaces of planetary and brake assembly are clean. Position new gasket to brake assembly.

3. Position brake assembly to machine, aligning splined brake shaft with input shaft on planetary wheel drive.

4. Make sure that gasket is properly positioned and then install flange head screws (11) to secure brake assembly to planetary assembly. Tighten screws in a crossing pattern to a torque of 60 ft-lb (81 N-m).

5. Install brake cable to pull rod on brake assembly. Brake cable end should be completely threaded onto pull rod.

6. Install new o-ring on hydraulic wheel motor. Install wheel motor (see Rear Wheel Motors in Service and Repairs section of Chapter 4 – Hydraulic System).



## WARNING

**Failure to maintain proper lug nut torque could result in failure or loss of wheel and may result in personal injury.**

7. Install wheel assembly with valve stem facing out. Torque lock nuts 90 ft-lb (122 N-m) to secure wheel assembly.

8. Lower machine to ground.

9. Make sure drain plug is installed in bottom of brake assembly (Fig. 8). Fill planetary wheel drive/brake assembly to proper level with SAE 85W-140 gear lube (see Operator's Manual).

10. Check and adjust brake cables for proper brake operation (see Operator's Manual).

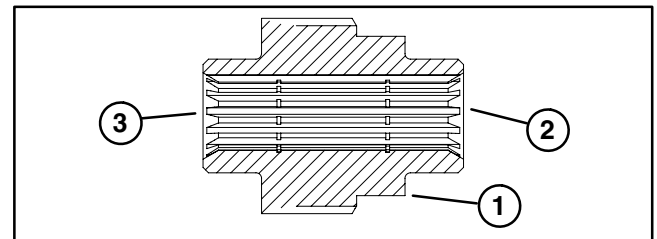

Figure 7

- 1. Splined brake shaft step
- 2. Hydraulic motor end
- 3. Planetary assembly end

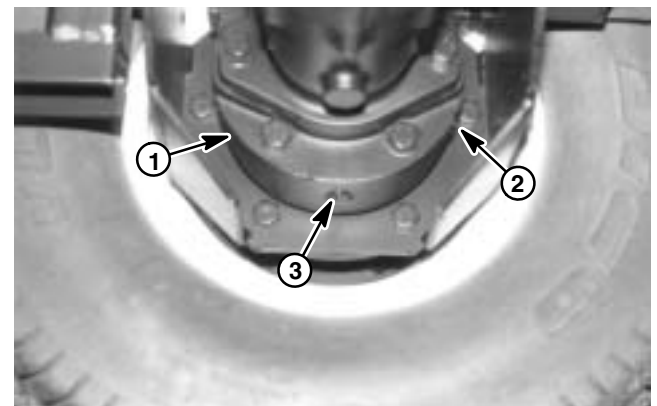

Figure 8

- 1. Brake housing
- 2. Check plug
- 3. Drain plug

## Brake Inspection and Repair

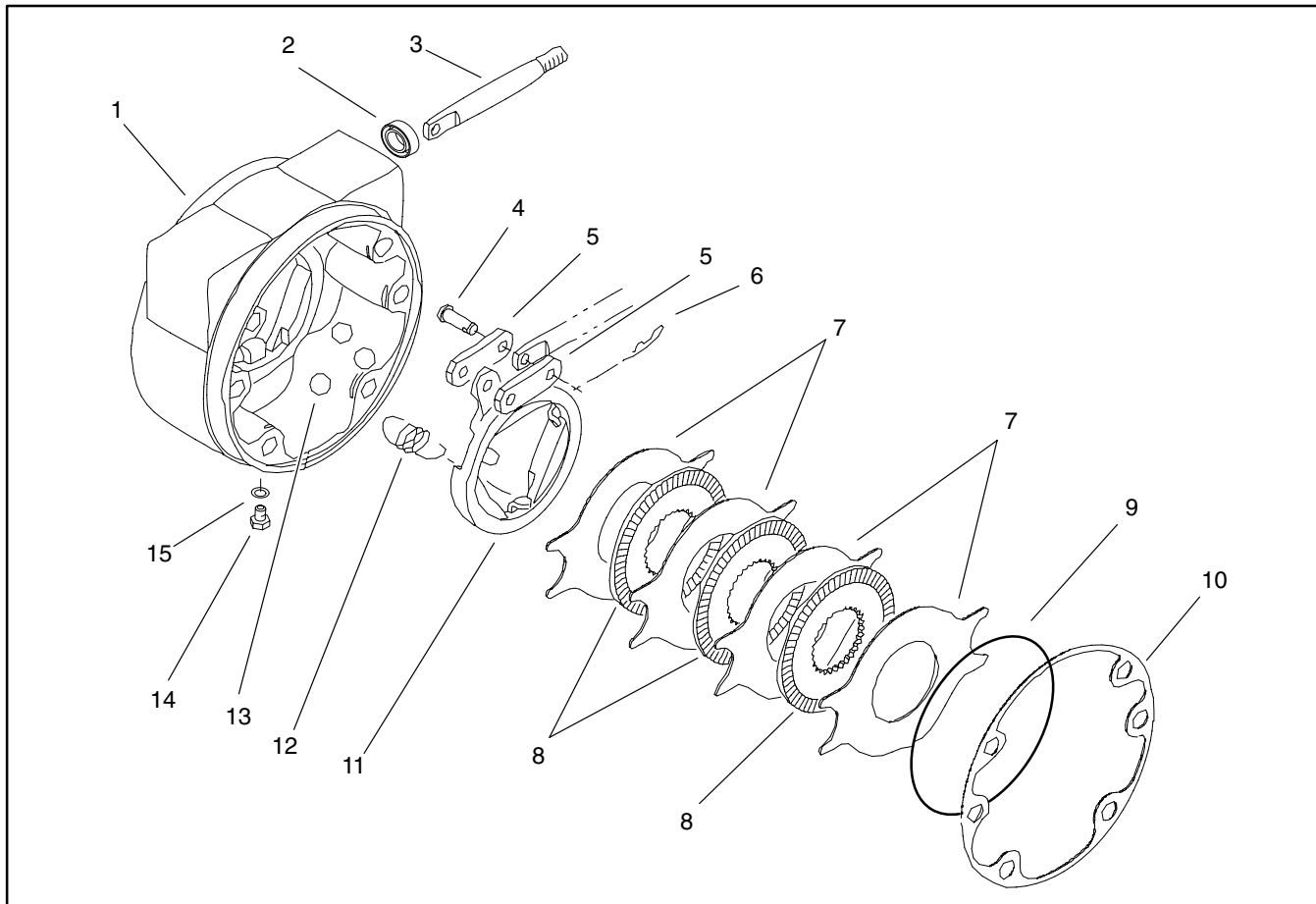

Figure 9

- |                             |                       |                               |
|-----------------------------|-----------------------|-------------------------------|
| 1. Brake housing (LH shown) | 6. Hitch pin (2 used) | 11. Rotating actuator         |
| 2. Seal                     | 7. Stationary disc    | 12. Extension spring (3 used) |
| 3. Pull rod                 | 8. Rotating disc      | 13. Ball (3 used)             |
| 4. Clevis pin               | 9. Retaining ring     | 14. Plug (2 used)             |
| 5. Link (2 used)            | 10. Gasket            | 15. O-ring                    |

### Brake Inspection and Repair (Fig. 9)

1. Scrape gasket material (10) from brake housing and planetary wheel drive mounting surfaces.
2. Remove retaining ring (9).
3. Remove four stationary discs (7) and three rotating discs (8).
4. Remove three extension springs (12).
5. Remove actuator assembly (3, 4, 5, 6, and 11) and three balls (13).
6. Remove seal (2) from brake housing.
7. Wash parts in cleaning solvent. Inspect components for wear or damage.
8. Reverse steps 2 – 6 to assemble brakes, installing new parts as necessary. Install a new seal (2).
9. Use a new gasket (10) when installing the brake assembly to machine.

## Brake Cables

### Removal

1. Remove brake cable from brake equalizer at front of machine under floorboard (Fig. 10 and 11):

A. Remove cotter pin, flat washer, and clevis pin that secure brake cable to brake equalizer.

B. Loosen jam nuts that secure cable to cable bracket on frame.

2. Remove brake cable from rear brake (Fig. 12):

A. Loosen and remove cable end from pull rod on brake assembly.

B. Loosen jam nut that secures brake cable to cable bracket on frame.

3. Remove R-clamp that secures brake cable:

A. R-clamp for right side cable is on top of traction pump.

B. R-clamp for left side cable is inside left frame rail.

4. Note routing of brake cable and remove cable from machine.

### Installation

1. Install brake cable to rear brake assembly:

A. Insert rear end of cable through cable bracket on frame and through hole in rear axle frame.

B. Connect cable end to brake pull rod on brake assembly. Tighten cable end.

C. Place cable in cable bracket. Secure with jam nut.

2. Route brake cable to front of machine.

3. Install brake cable to brake equalizer:

A. Pass cable through cable bracket on frame and position cable to brake equalizer.

B. Attach cable to equalizer with clevis pin, flat washer, and cotter pin.

C. Position cable to cable bracket and adjust cable free play with jam nuts. There should be no slack in cable and brake equalizer should be perpendicular to vehicle centerline after adjustment.

4. Secure cable to machine with R-clamp.

5. Check operation of brakes before using the machine.

Multi Pro 5600

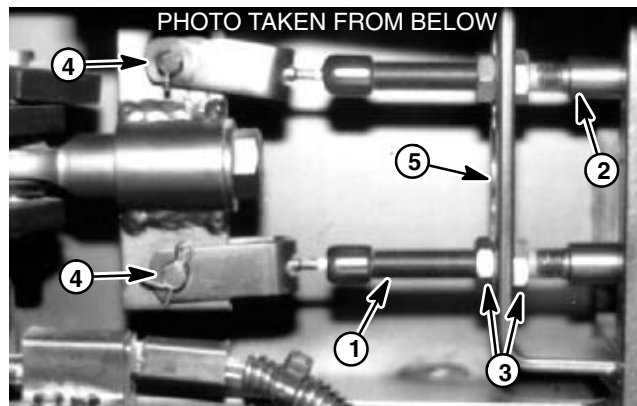

Figure 10

- |                   |                        |
|-------------------|------------------------|
| 1. RH brake cable | 4. Clevis pin          |
| 2. LH brake cable | 5. Frame cable bracket |
| 3. Cable jam nut  |                        |

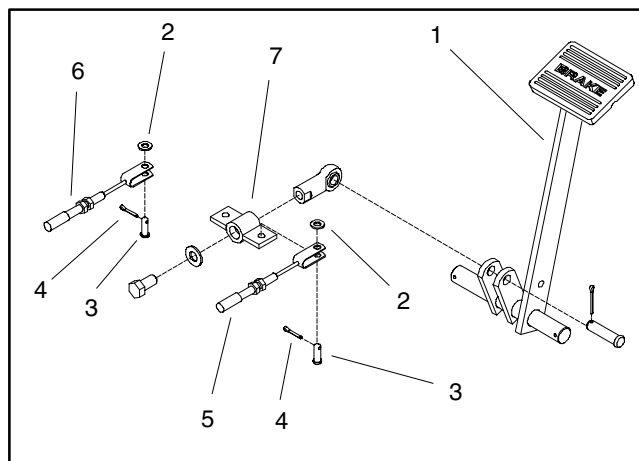

Figure 11

- |                   |                    |
|-------------------|--------------------|
| 1. Brake pedal    | 5. RH brake cable  |
| 2. Brake pull rod | 6. LH brake cable  |
| 3. Clevis pin     | 7. Brake equalizer |
| 4. Cotter pin     |                    |

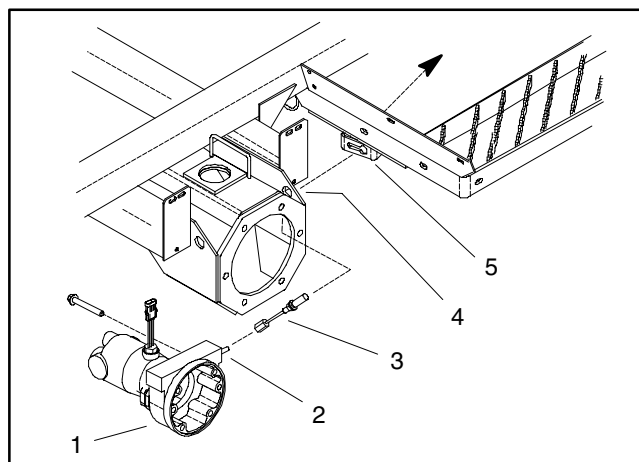

Figure 12

- |                           |                    |
|---------------------------|--------------------|
| 1. Brake (RH shown)       | 4. Axle frame hole |
| 2. Brake pull rod         | 5. Cable bracket   |
| 3. Brake cable (RH shown) |                    |

# Planetary Wheel Drive Assembly

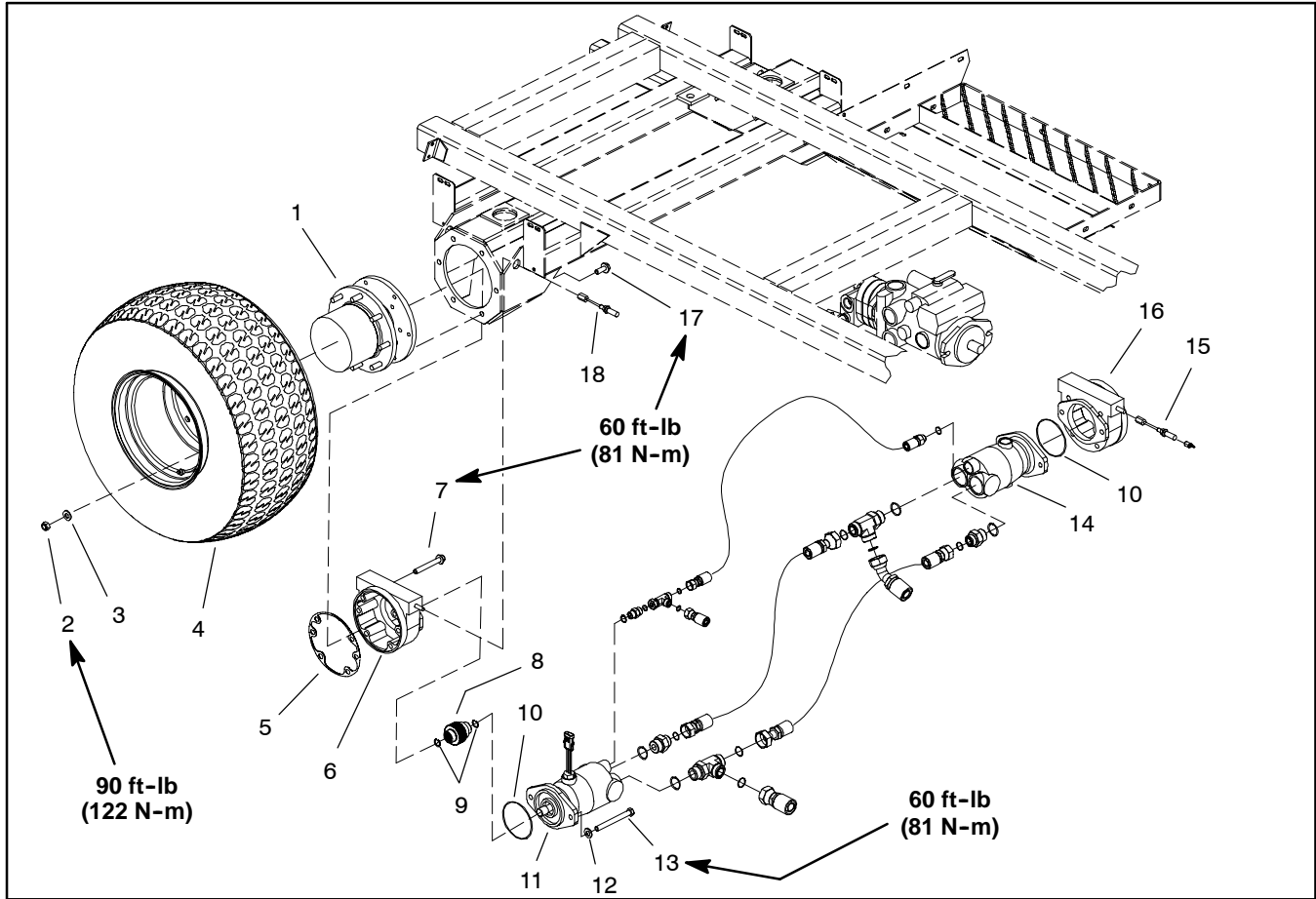

Figure 13

- |                                   |   |   |
|-----------------------------------|---|---|
| 1. Planetary assembly             | 7. Flange head screw (4 used per brake) | 13. Cap screw (2 used per motor)        |
| 2. Lock nut (8 used per wheel)    | 8. Splined brake shaft                  | 14. LH wheel motor                      |
| 3. Flat washer (8 used per wheel) | 9. Retaining ring                       | 15. LH brake cable                      |
| 4. Tire and wheel assembly        | 10. O-ring                              | 16. LH brake assembly                   |
| 5. Gasket                         | 11. RH wheel motor (with speed sensor)  | 17. Flange head screw (6 used per side) |
| 6. RH brake assembly              | 12. Flat washer (2 used per motor)      | 18. RH brake cable                      |

**NOTE:** The planetary wheel drive assembly can be serviced with the planetary installed to machine (see Planetary Wheel Drive Service in this section). Use the following procedure to remove and install planetary wheel drive assembly from machine.



### Removal (Fig. 13)

1. Park machine on a level surface, stop engine, engage parking brake, and remove key from the ignition switch.
2. Drain oil from planetary wheel drive/brake assembly (see Operator's Manual).

 **CAUTION**

**When changing attachments, tires, or performing other service, use correct blocks, hoists, and jacks. Make sure machine is parked on a solid, level surface such as a concrete floor. Prior to raising machine, remove any attachments that may interfere with the safe and proper raising of the machine. Always chock or block wheels. Use jack stands or solid wood blocks to support the raised machine. If the machine is not properly supported by blocks or jack stands, the machine may move or fall, which may result in personal injury.**

3. Chock front wheels and jack up rear of machine (see Jacking Instructions in Operator's Manual). Support machine with jack stands or solid wood blocks.
4. Remove rear wheel assembly.
5. Support wheel motor and brake assembly to prevent them from shifting during planetary removal.
6. Remove two (2) cap screws and flat washers that secure wheel motor to planetary assembly.
7. Remove four (4) flange head screws that secure brake assembly to planetary assembly (see Brake Assembly).
8. Support planetary assembly to prevent it from falling. Loosen and remove eight (8) flange head screws that secure planetary assembly to frame. Remove planetary assembly from machine.

### Installation (Fig. 13)

1. Make sure that gasket surfaces of planetary and brake assembly are clean. Position new gasket to brake assembly.
2. Position planetary assembly to machine making sure to engage splined brake shaft with planetary drive shaft. Install eight (8) flange head screws to secure planetary assembly to frame. Torque screws 60 ft-lb (81 N-m).
3. Make sure that gasket is properly positioned and then secure brake assembly to planetary (see Brake Assembly).

Multi Pro 5600

4. Secure wheel motor to planetary with two (2) cap screws and flat washers. Torque screws 60 ft-lb (81 N-m).

 **WARNING**

**Failure to maintain proper wheel lug nut torque could result in failure or loss of wheel and may result in personal injury.**

5. Install wheel assembly with valve stem facing out. Torque lug nuts 90 ft-lb (122 N-m).
6. Lower machine from jack stands.
7. Make sure drain plug is installed in bottom of brake assembly (Fig. 14). Fill planetary wheel drive/brake assembly to proper level with SAE 85W-140 gear lube (see Operator's Manual). Capacity is approximately 16 oz. (.47 l) per wheel.
8. Check and adjust brake cables for proper brake operation (see Operator's Manual).

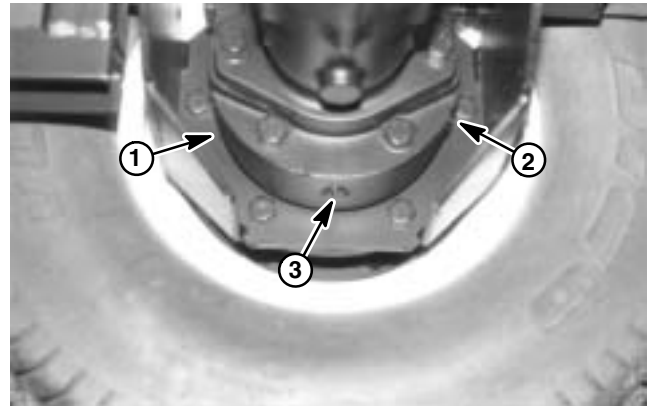

Figure 14

1. Brake housing
2. Check plug
3. Drain plug

# Planetary Wheel Drive Service

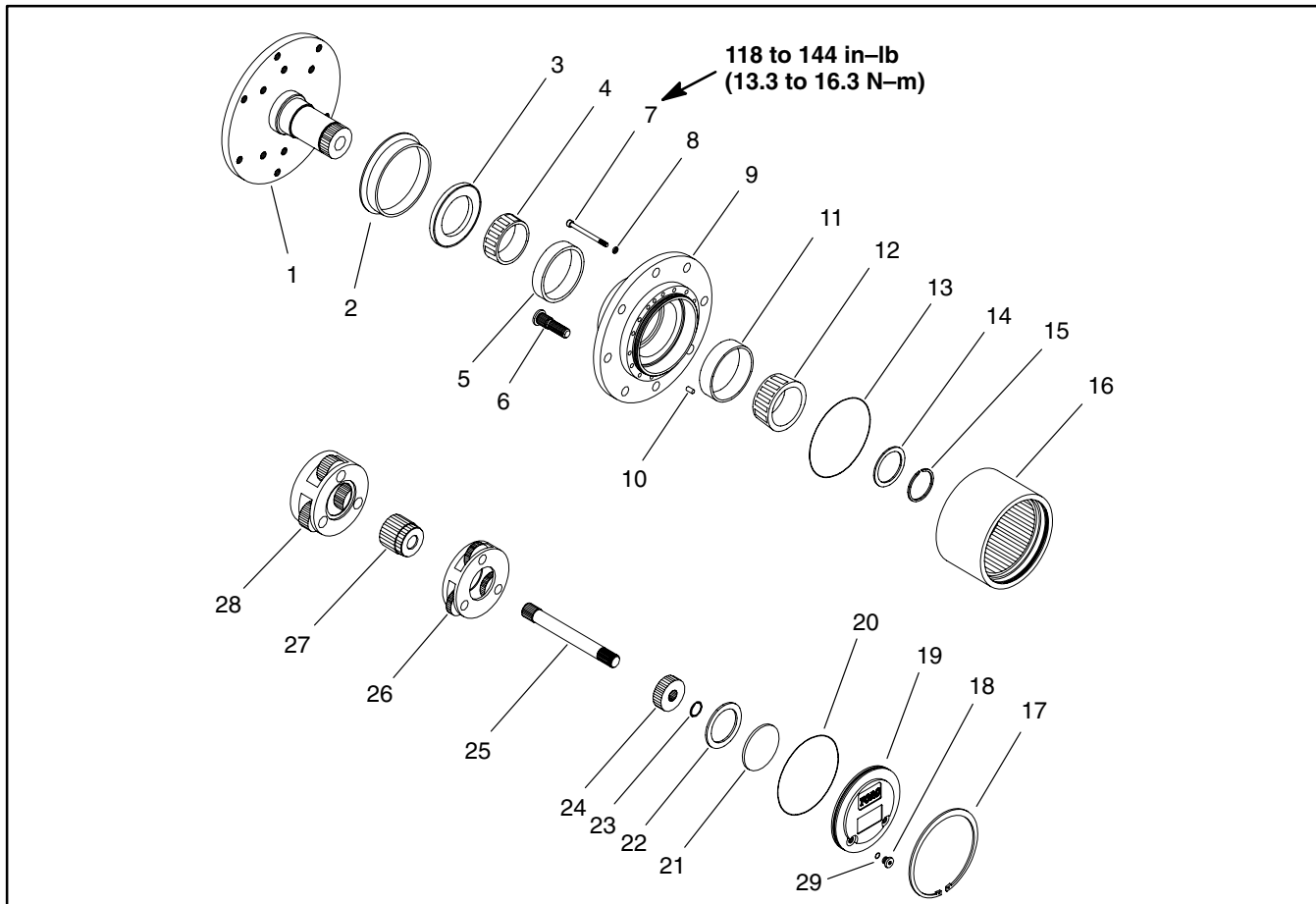

Figure 15

- |                                |                    |                       |
|--------------------------------|--------------------|-----------------------|
| 1. Spindle                     | 11. Bearing cup    | 21. Thrust plug       |
| 2. Boot seal                   | 12. Bearing cone   | 22. Thrust washer     |
| 3. Oil seal                    | 13. O-ring         | 23. Retaining ring    |
| 4. Bearing cone                | 14. Bearing shim   | 24. Primary gear      |
| 5. Bearing cup                 | 15. Snap ring      | 25. Drive shaft       |
| 6. Wheel stud (8 used)         | 16. Ring gear      | 26. Primary carrier   |
| 7. Socket head screw (16 used) | 17. Retaining ring | 27. Secondary gear    |
| 8. Lock washer (16 used)       | 18. Plug           | 28. Secondary carrier |
| 9. Housing                     | 19. End cap        | 29. O-ring            |
| 10. Dowel pin                  | 20. O-ring         |                       |

**NOTE:** The planetary wheel drive assembly can be serviced with the planetary installed to machine. If the spindle (item 1) needs to be removed from machine, see Planetary Wheel Drive Assembly in this section.

### Disassembly (Figs. 15 and 16)

1. If planetary wheel drive assembly is installed on machine:

A. Park machine on a level surface, lower cutting decks, stop engine and remove key from the ignition switch.

B. Drain oil from planetary wheel drive/brake assembly.

C. Chock rear wheels and jack up front of machine (see Jacking Instructions in Chapter 1 - Safety). Support machine with jack stands.

D. Remove front wheel assembly.

2. Remove retaining ring (item 17).

3. Remove end cap (item 20). Thrust plug (item 21) and thrust washer (item 22) usually remain in end cap bore and should be removed for cleaning and inspection.

4. Remove drive shaft assembly (items 23, 24 and 25) If necessary, remove retaining ring and primary gear from shaft.

5. Remove primary carrier (item 26), secondary gear (item 27) and secondary carrier (item 28).

**NOTE:** Steps 6 through 10 are necessary only if inspecting or replacing bearings and/or seals.

**IMPORTANT: Do not reuse retaining ring (item 10) after it has been removed.**

6. Remove retaining ring (item 15) and thrust washer (item 14). Discard retaining ring.

7. Carefully remove housing (item 9) from spindle (item 1). Remove outer bearing cone (item 12).

8. Remove and discard seals (items 2 and 3) and O-rings (item 13) from housing.

9. Remove inner bearing cone (item 4) from housing. If necessary, remove bearing cups (items 5 and 11) from housing.

10. If wheel stud (item 6) removal is necessary, use press to extract stud(s) from housing.

11. If necessary, remove socket head screws (item 7) with lock washers (item 8) that secure ring gear (item 16) to housing. Remove ring gear and two (2) dowel pins (item 10) from housing.

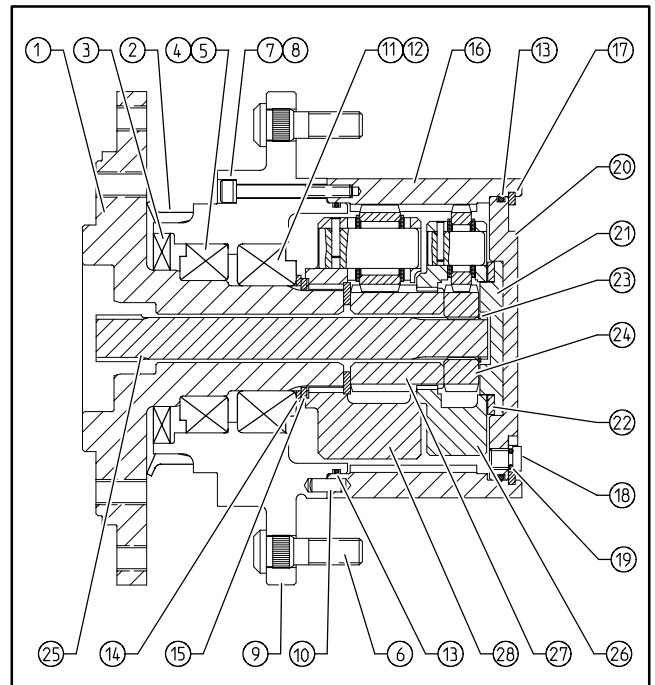

Figure 16

### Assembly (Figs. 15 and 16)

1. Thoroughly clean parts in solvent and dry completely after cleaning. Inspect parts for damage or excessive wear and replace as necessary.

2. If any wheel studs were removed, use a press to install new studs into housing. Make sure that stud shoulder is fully pressed against housing surface.

**NOTE:** Use new seal and shim kits when assembling planetary wheel drive.

3. If spindle and housing were separated:

A. Press bearing cups (items 5 and 11) into housing (item 9). Cups should be pressed fully to shoulder of the housing bore.

B. Set inner bearing cone (item 4) into inner bearing cup.

C. Make sure that seal bore in housing is thoroughly cleaned. If OD of seal (item 3) is not rubber or does not have a sealant coating, apply light coating of silicone sealant to seal bore in housing. Install seal into housing so it is flush with housing face. Lightly grease seal lips.

D. Pack boot seal (item 2) with grease and install on housing.

E. If ring gear was removed from housing, place dowel pins (item 10) in housing. Secure ring gear to housing with lock washers (item 8) and socket head screws (item 7). Torque socket head screws from 118 to 144 in-lb (13.3 to 16.3 N-m).

F. Lightly oil bearing journals on spindle shaft. Slide housing assembly onto spindle (item 1) taking care to not damage seal or spindle. Make sure that inner bearing in housing fully seats against spindle shaft shoulder.

G. Install outer bearing cone (item 12) onto spindle.

**NOTE:** The planetary shim kit includes the retaining ring and several thrust washers with thickness in incremental steps of 0.004 in. (0.10 mm).

H. Measure thickness of thrust washer (item 14) that was removed during disassembly. Choose new thrust washer of equal thickness or the next available thickness from thrust washers in the shim kit.

I. Apply a light coating of oil to spindle shaft, thrust washer (item 14) and new retaining ring (item 15). Install thrust washer onto spindle shaft.

 <b>WARNING</b>
<b>If retaining ring (item 15) is not fully installed in spindle groove, loss of wheel and personal injury may result.</b>

J. Carefully install new retaining ring (item 15) into the spindle shaft groove taking care to not distort ring. If the proper thrust washer has been installed, the retaining ring should fit tightly between the thrust washer and spindle groove. Tap the OD of the retaining ring starting in the center and working out toward each end to ensure that the retaining ring is properly seated into the spindle groove. Make sure that retaining ring ID is fully seated to spindle shaft groove.

K. After retaining ring is installed, make sure that there is no endplay in assembly. If required, remove retaining ring and install a thrust washer of different thickness to adjust endplay.

L. Install new O-ring (item 13) into groove in housing.

4. Install secondary carrier (item 28), secondary gear (item 27) and primary carrier (item 26) making sure that carrier gear teeth align with ring gear and spline on spindle shaft.

5. If primary gear (item 24) was removed from drive shaft, slide gear onto shaft and secure with retaining ring (item 23).

6. Install drive shaft assembly (items 25, 24 and 23) making sure that drive shaft spline aligns with carrier gears.

7. Install thrust plug (item 21) and thrust washer (item 22) into end cap (item 20). Make sure that thrust plug and thrust washer are captive on inside of end cap (item 20).

8. Install new O-ring (item 13) to end cap and then install end cap. Secure cap with retaining ring (item 17).

9. Check operation of planetary wheel drive. With a constant turning force applied, rotation of the planetary should be consistent. If there is more drag at certain points, gears are not rolling freely and the planetary should be examined for improper assembly or damaged components.

10. If planetary wheel drive assembly is installed on machine:

A. Install front wheel assembly.

 <b>WARNING</b>
<b>Failure to maintain proper wheel lug nut torque could result in failure or loss of wheel and may result in personal injury.</b>

B. Lower machine from jack stands. Torque wheel lug nuts in a crossing pattern from 70 to 90 ft-lb (95 to 122 N-m).

C. Make sure drain plug is installed in bottom of brake assembly. Fill planetary wheel drive/brake assembly with SAE 85W-140 gear lube to proper level. Capacity is approximately 16 oz. (0.47 l) per wheel.



Table of Contents

ELECTRICAL SCHEMATICS ..... 3  
    Vehicle Electrical Schematic (Serial Numbers  
        below 230000400) ..... 3  
    Vehicle Electrical Schematic (Serial Numbers  
        230000400 and above) ..... 4  
    Spray System Electrical Schematic ..... 5  
CIRCUIT DIAGRAMS ..... 6  
    Start Circuit Diagram ..... 6  
    Run Circuit Diagram ..... 7  
    Cruise Control Circuit Diagram ..... 8  
    Spray Circuit Diagram (Master Boom Switch ON) 9  
    Spray Circuit Diagram (Master Boom Switch OFF)10  
    Spray Circuit Application Rate Change Diagram . 11  
    Spray Circuit: Tank Agitation Diagram ..... 12  
WIRE HARNESS DRAWINGS ..... 13  
    Vehicle Wire Harness Drawing (Serial Numbers  
        below 230000400) ..... 13  
    Vehicle Wire Harness Drawing (Serial Numbers  
        below 230000400) ..... 14  
    Vehicle Wire Harness Drawing (Serial Numbers  
        230000400 and above) ..... 15  
    Vehicle Wire Harness Drawing (Serial Numbers  
        230000400 and above) ..... 16  
    Spray System Wire Harness Drawing ..... 17  
    Spray System Wire Harness Drawing ..... 18

This page is intentionally blank.

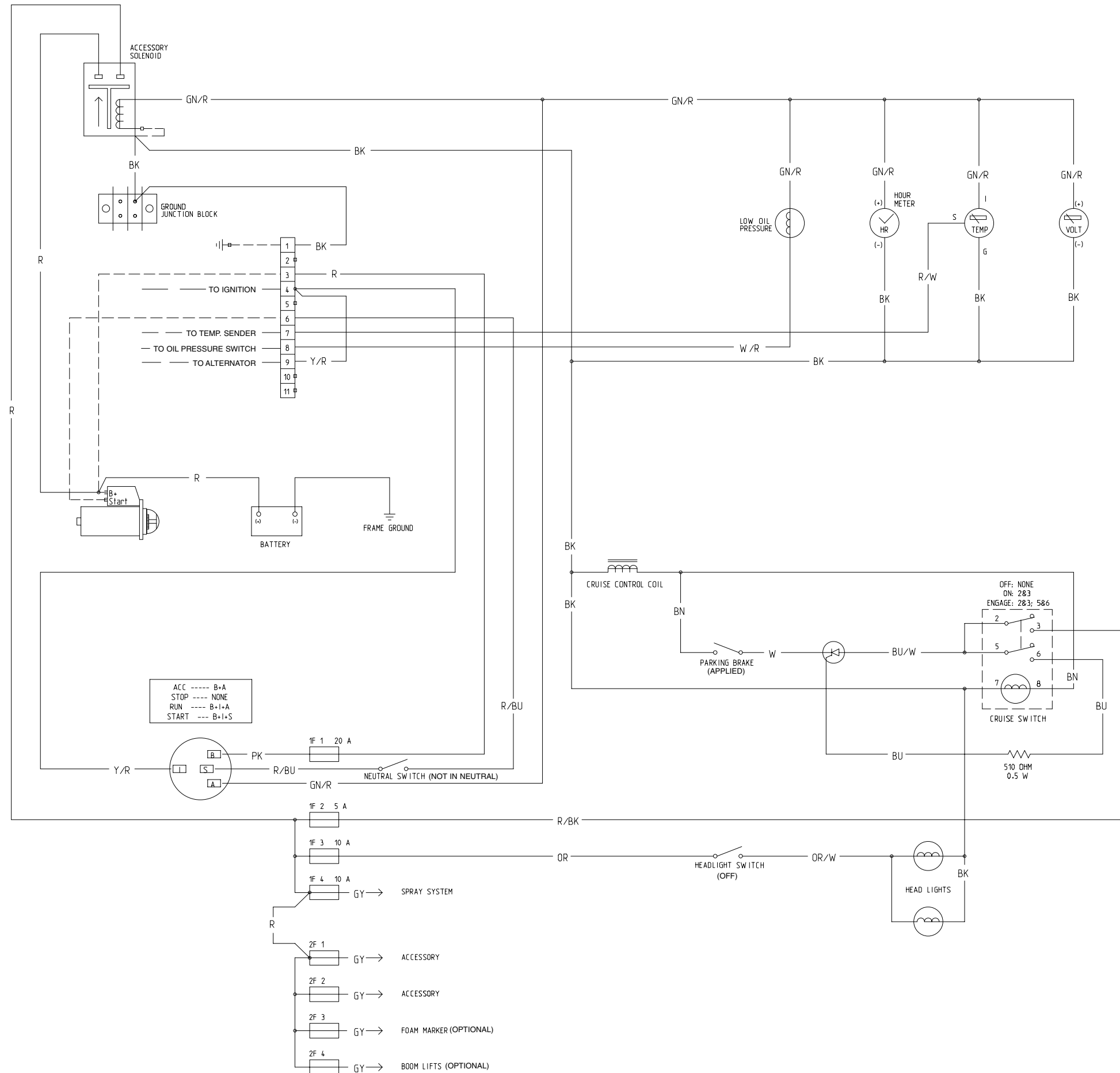

Multi Pro 5600  
**Vehicle Electrical Schematic**  
 (Serial Numbers below 230000400)

All relays and solenoids  
 are shown as de-energized.

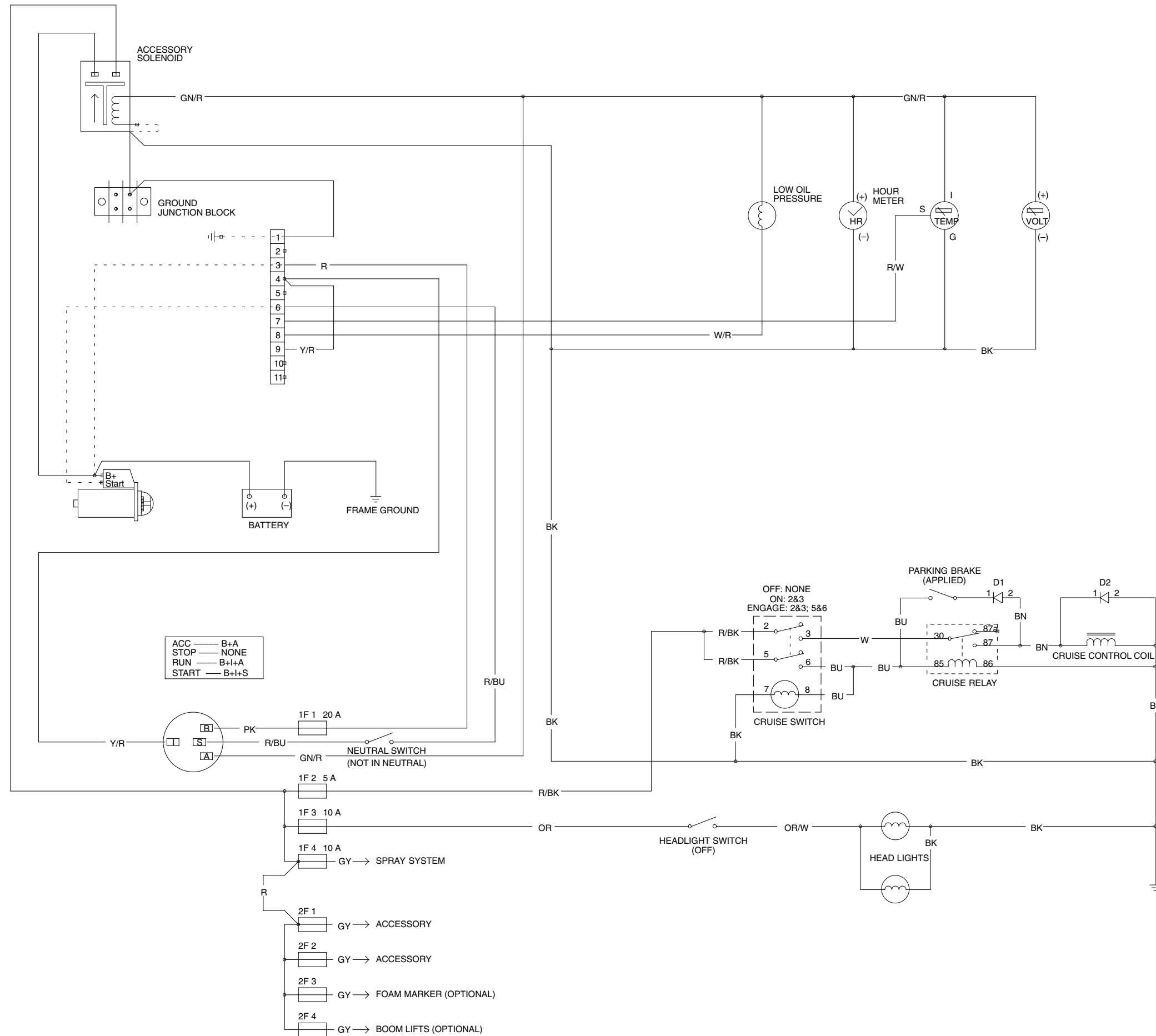

Multi Pro 5600  
**Vehicle Electrical Schematic**  
 (Serial Numbers 230000400 and above)

All relays and solenoids  
 are shown as de-energized.



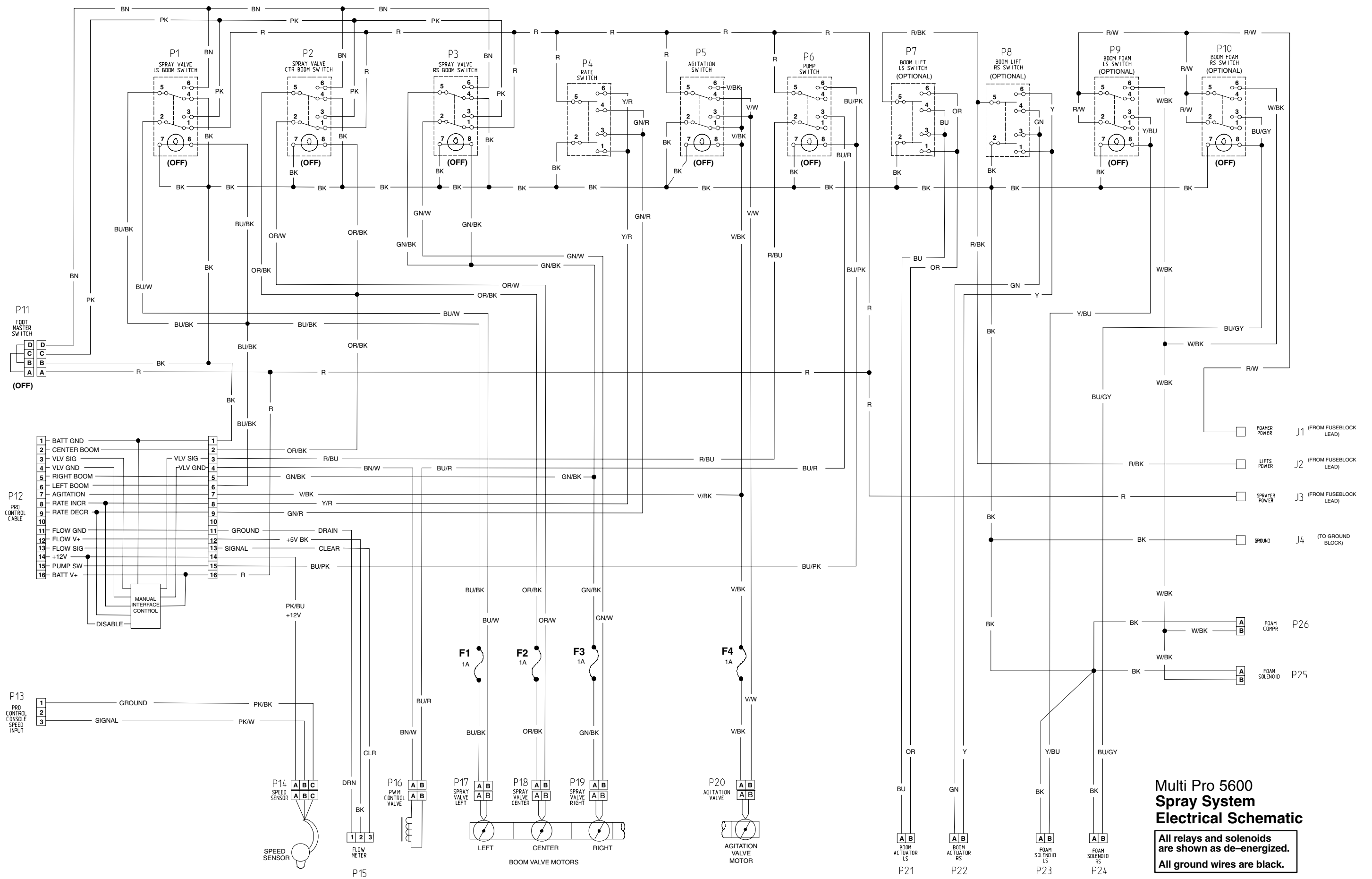

**Multi Pro 5600  
Spray System  
Electrical Schematic**

All relays and solenoids are shown as de-energized.  
All ground wires are black.

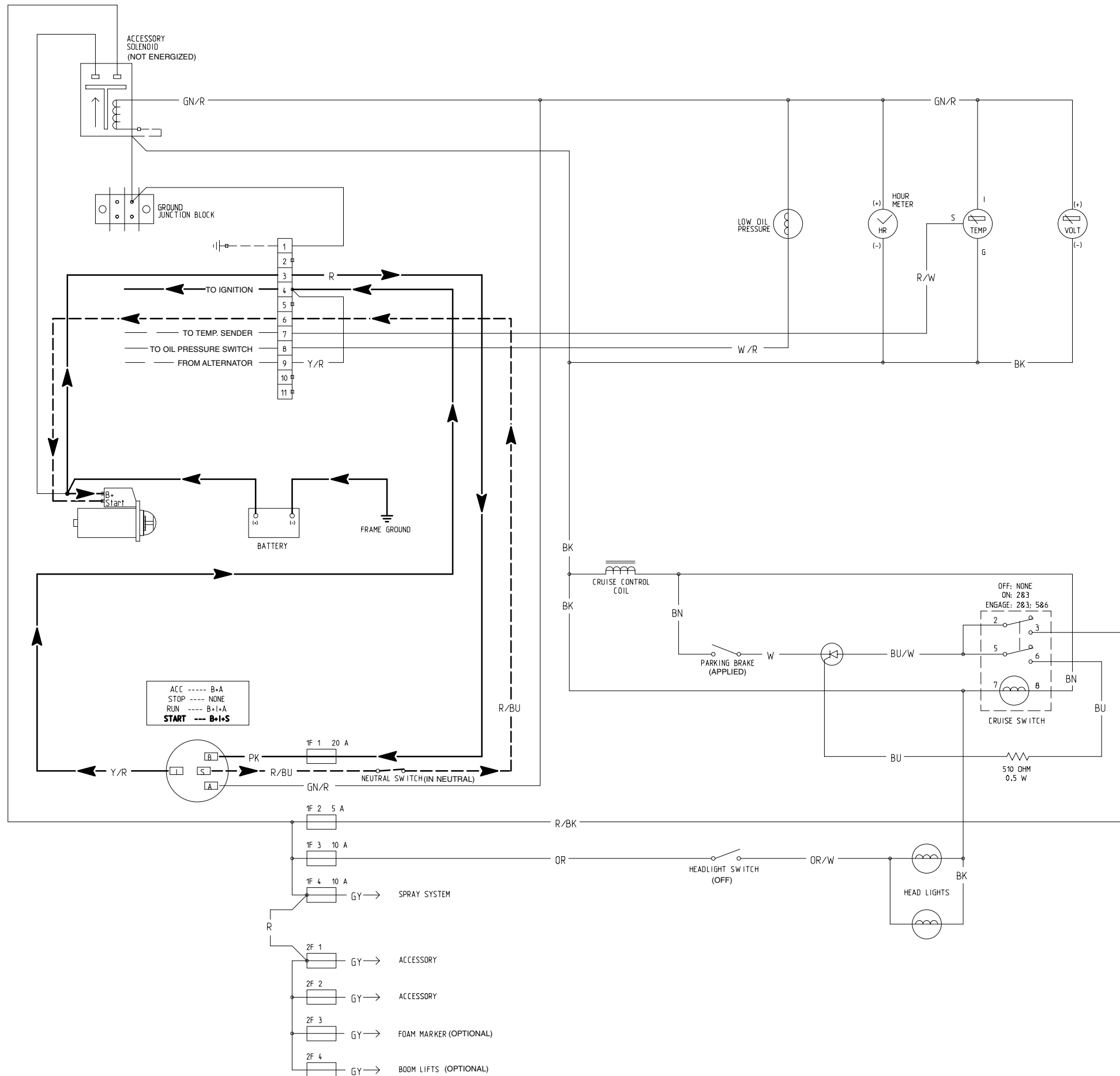

**Multi Pro 5600  
Start Circuit**

(Schematic from Serial Number below 230000400 shown)

- Power Current
- - - - Control Current
- Indicator/Gauge Current
- Logic Direction

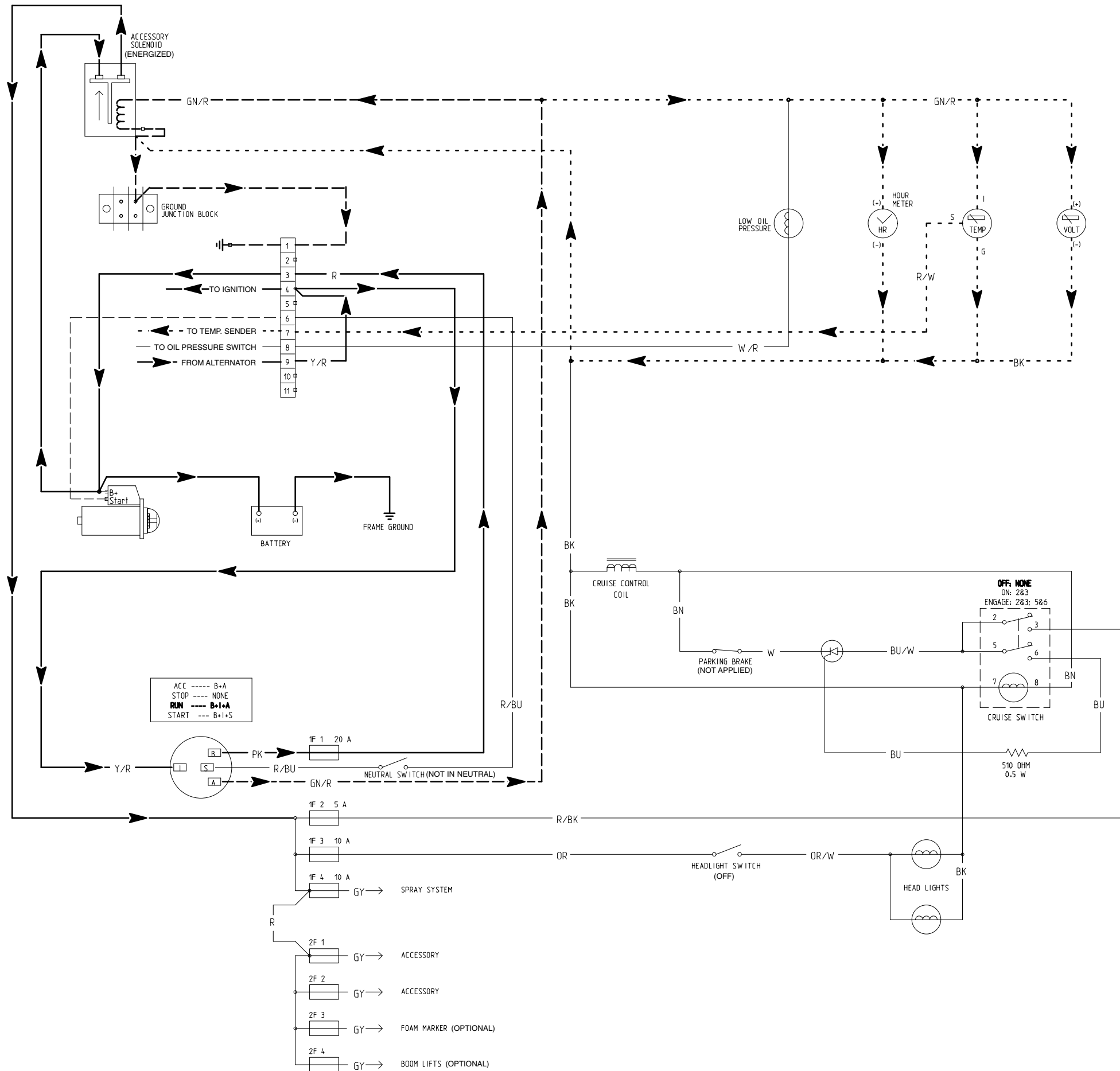

### Multi Pro 5600 Run Circuit

(Schematic from Serial Number below 230000400 shown)

- Power Current
- - - - Control Current
- · - · - · Indicator/Gauge Current
- Logic Direction

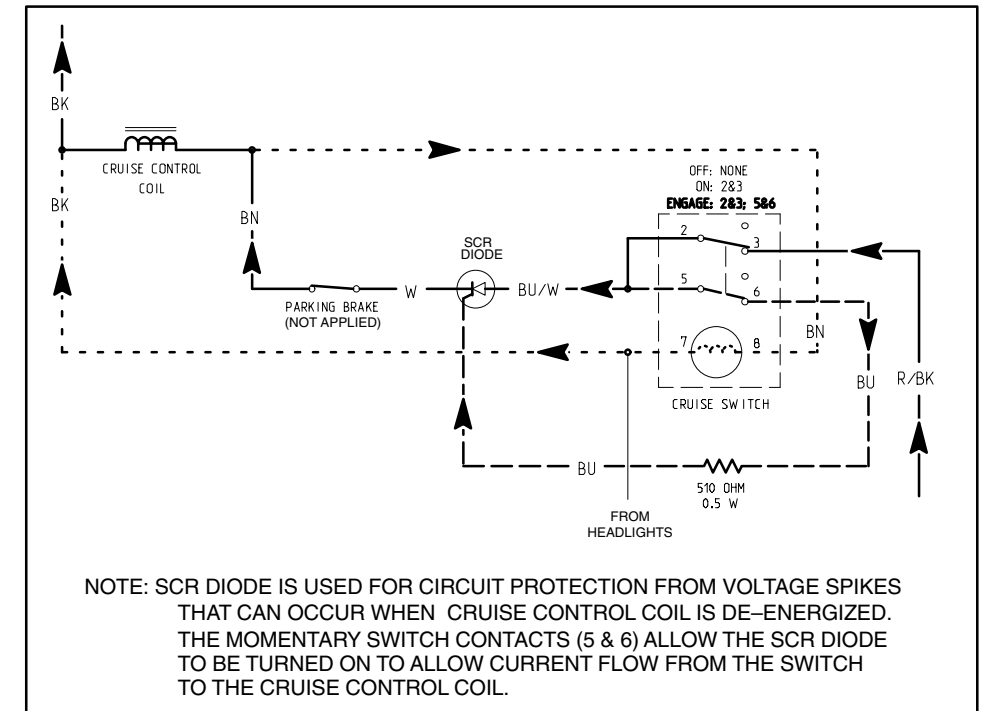
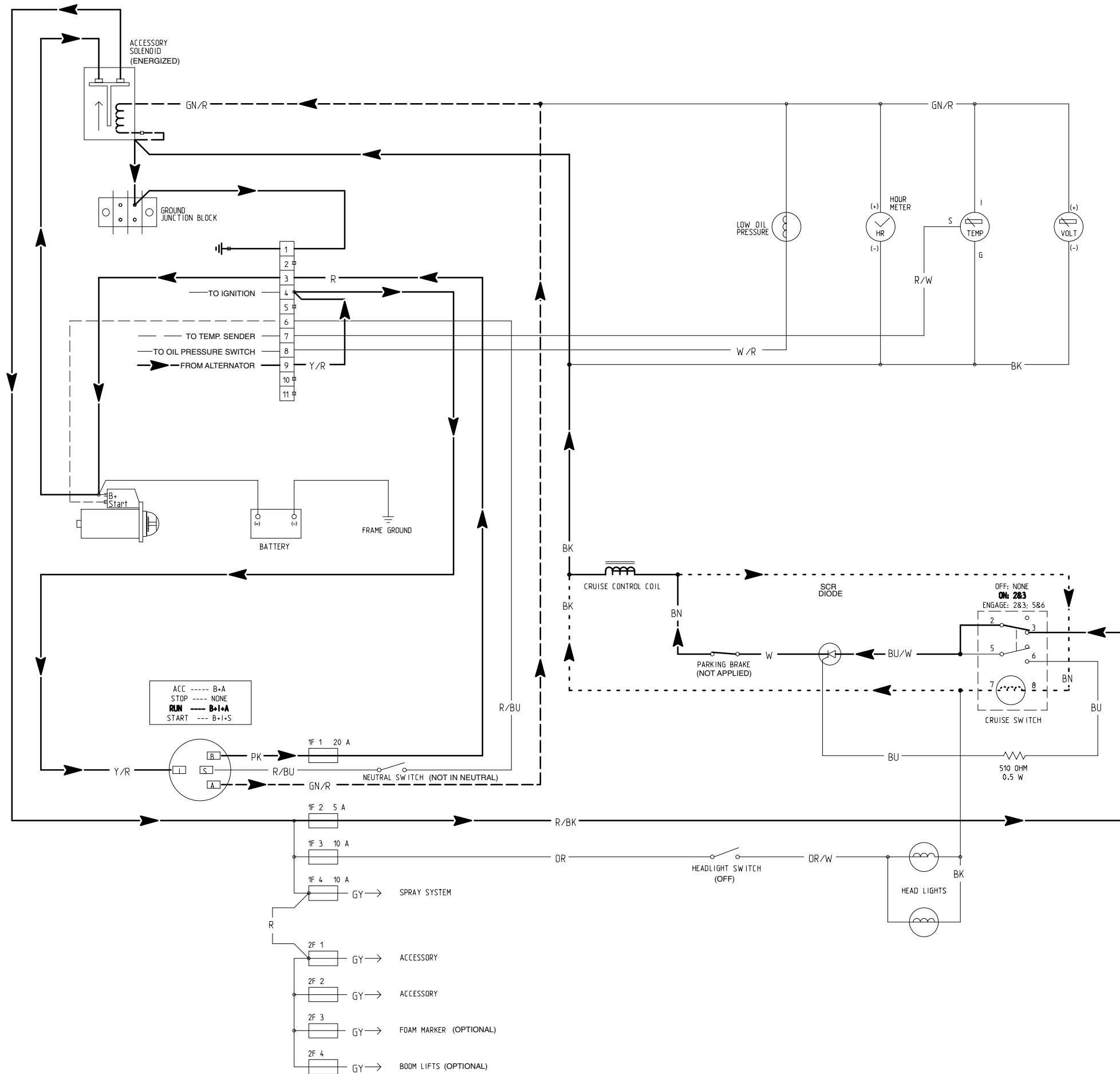

### Multi Pro 5600 Cruise Control Circuit

(Schematic from Serial Number below 230000400 shown)



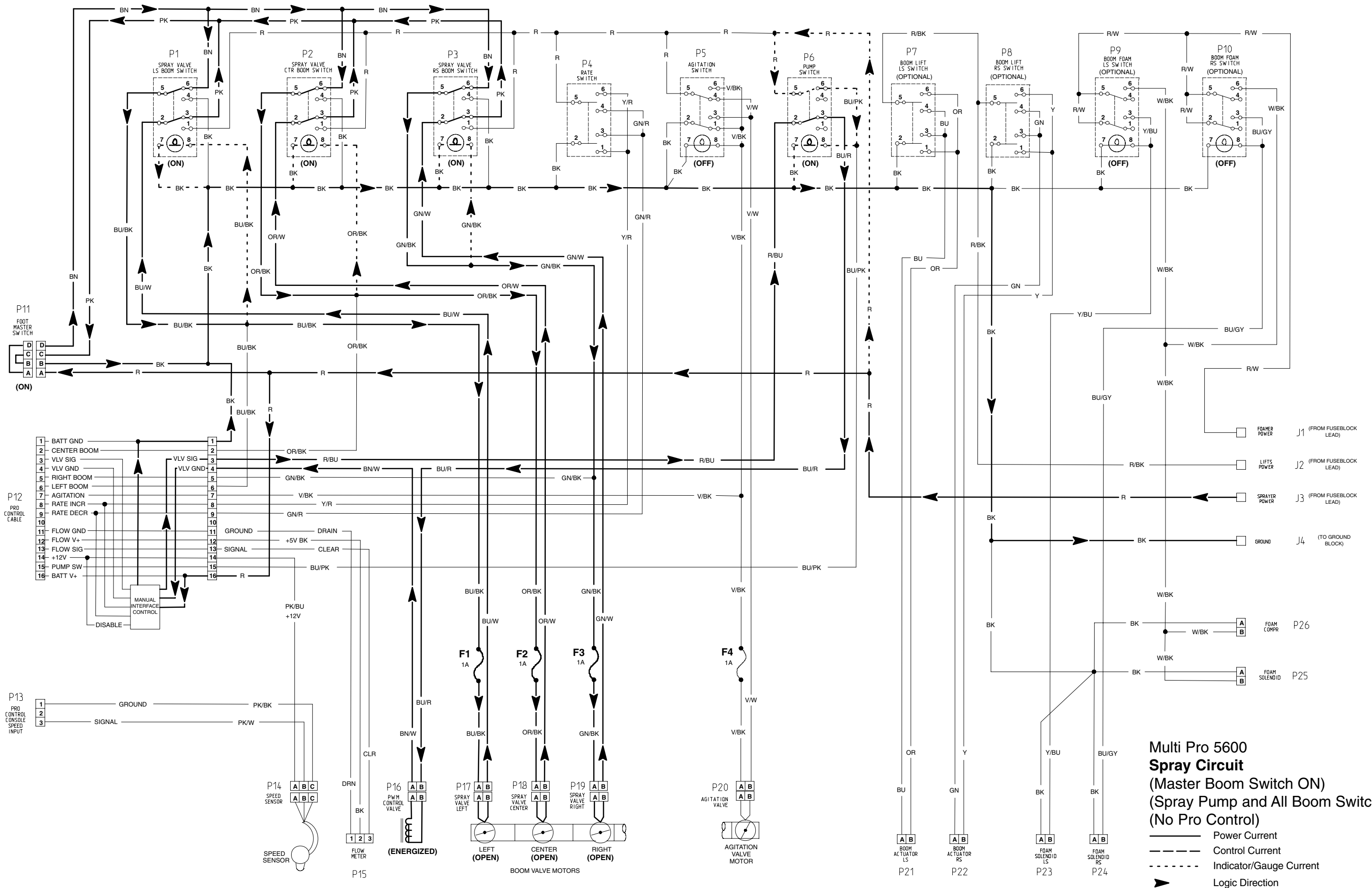

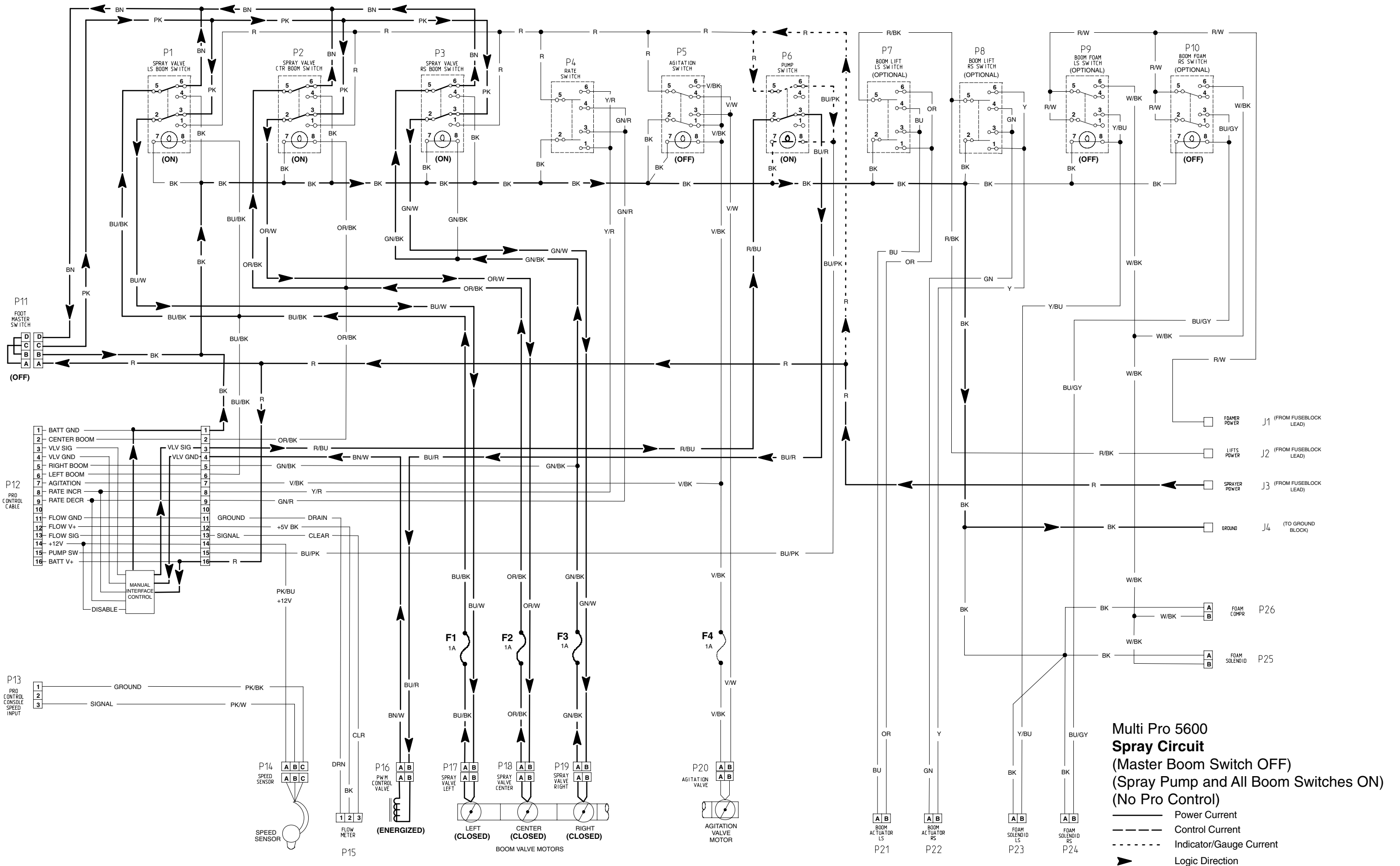
- Power Current
- - - Control Current
- - - - Indicator/Gauge Current
- Logic Direction

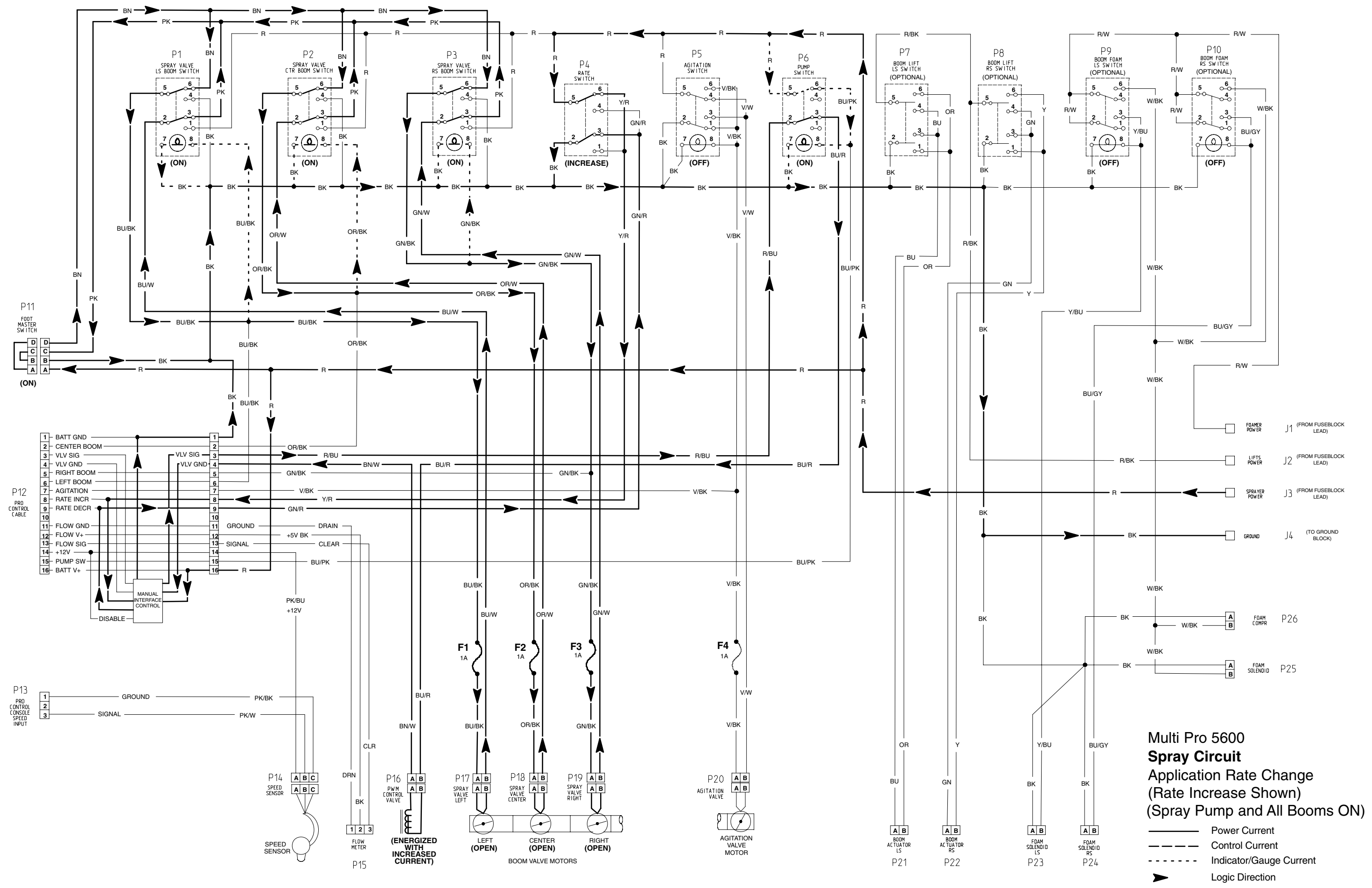





**Multi Pro 5600  
Spray Circuit  
Application Rate Change  
(Rate Increase Shown)  
(Spray Pump and All Booms ON)**

-  Power Current
-  Control Current
-  Indicator/Gauge Current
-  Logic Direction

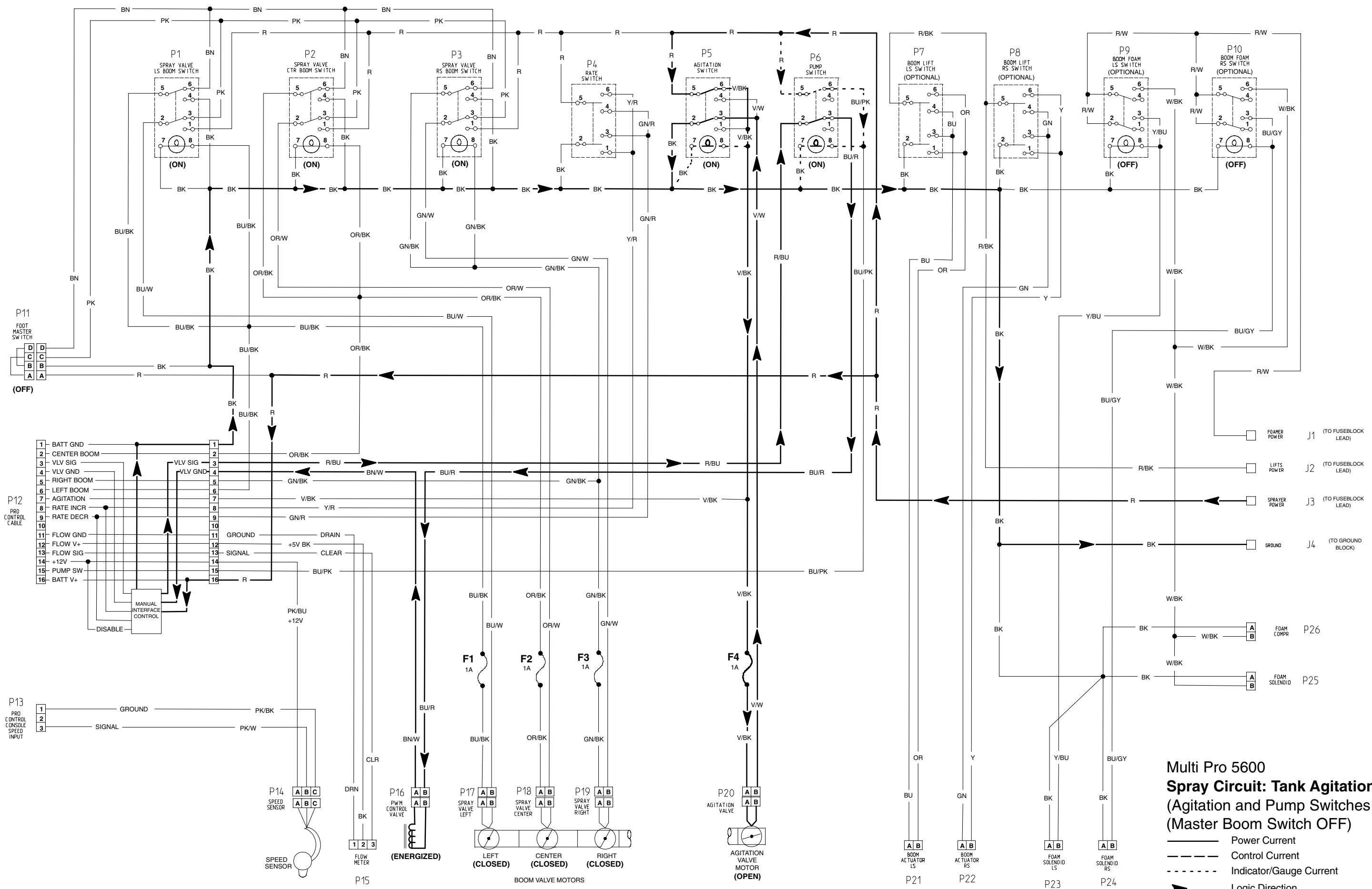

**Multi Pro 5600  
Spray Circuit: Tank Agitation  
(Agitation and Pump Switches ON)  
(Master Boom Switch OFF)**

- Power Current
- - - Control Current
- · · Indicator/Gauge Current
- Logic Direction



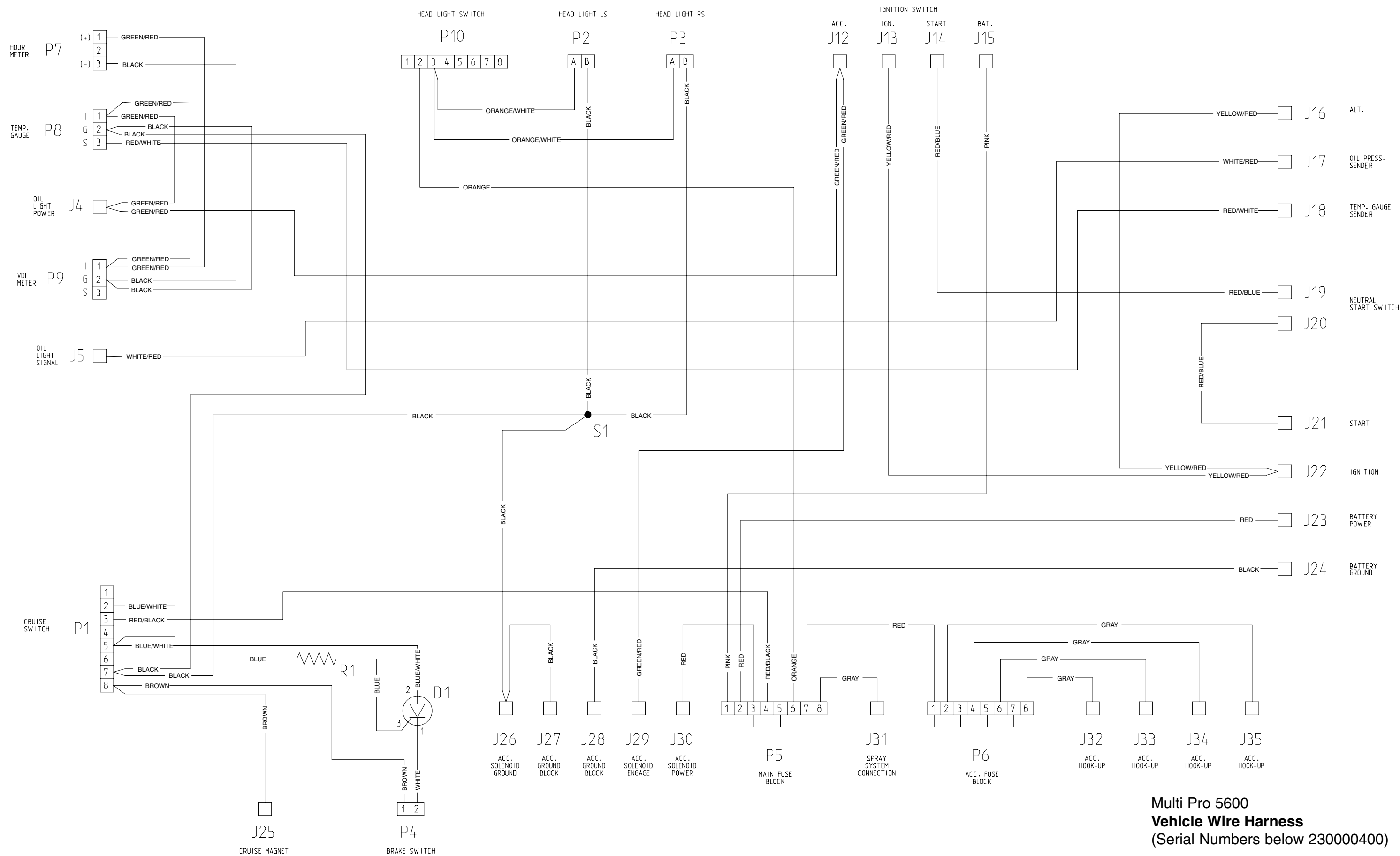

**Multi Pro 5600  
Vehicle Wire Harness  
(Serial Numbers below 230000400)**

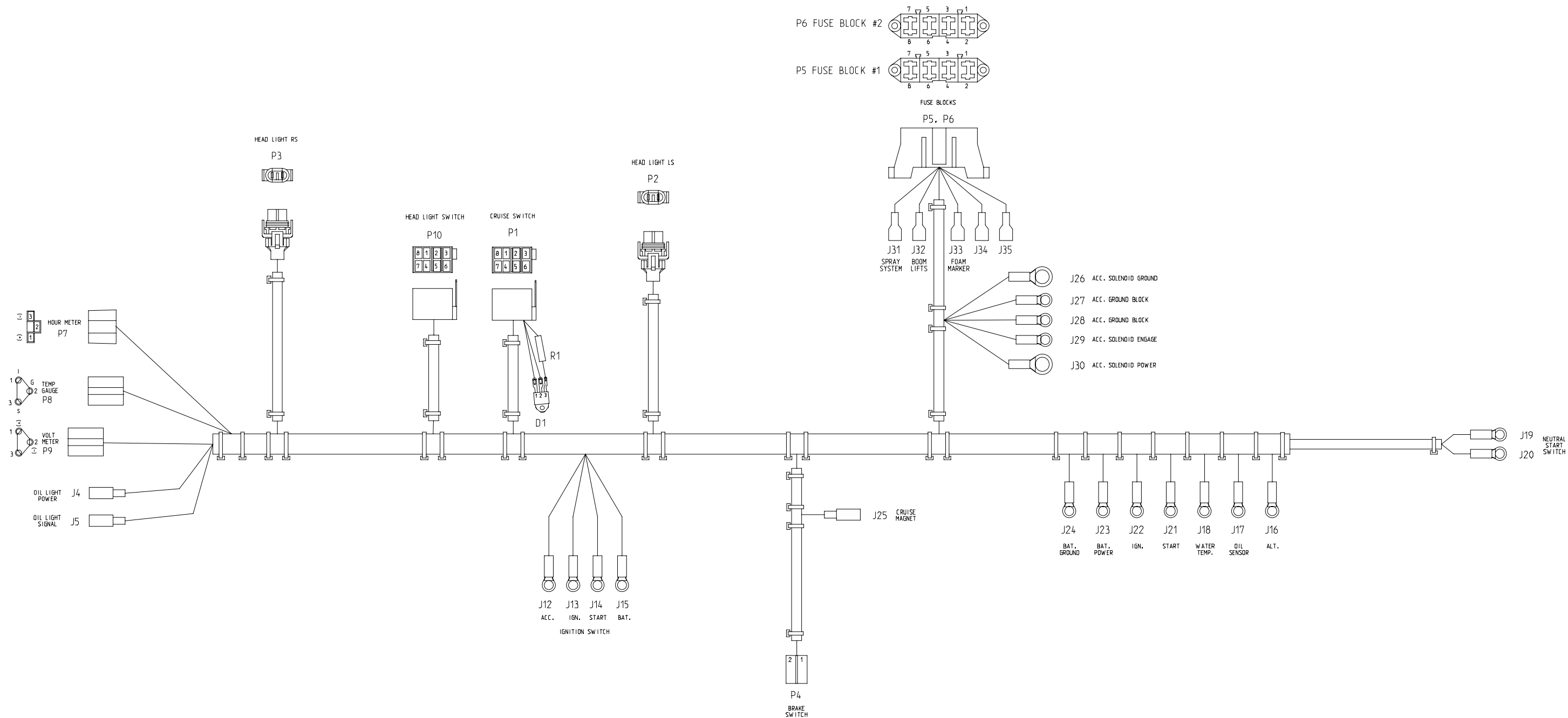

Multi Pro 5600  
**Vehicle Wire Harness**  
 (Serial Numbers below 230000400)

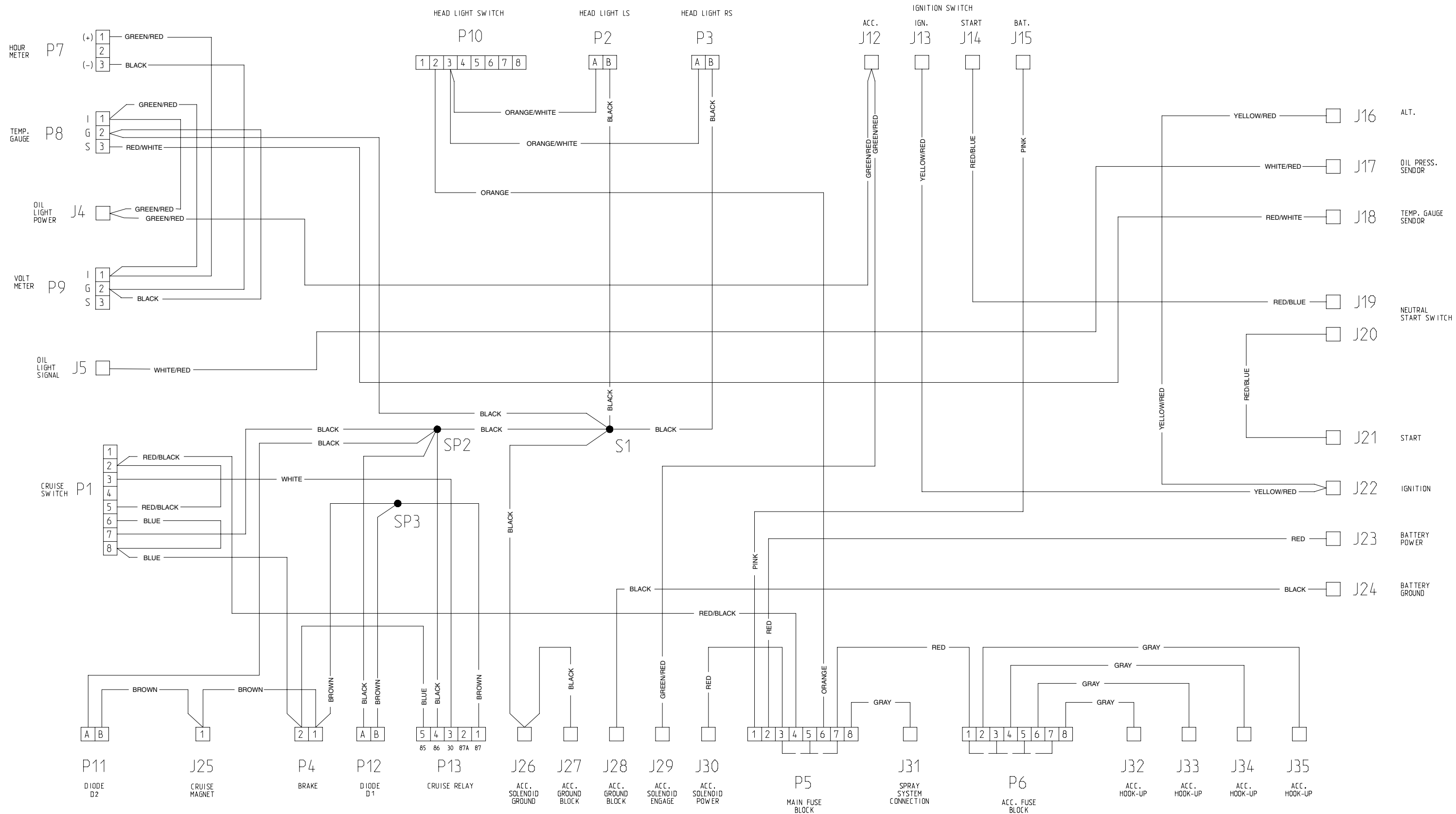

**Multi Pro 5600  
Vehicle Wire Harness**  
(Serial Numbers 230000400 and above)

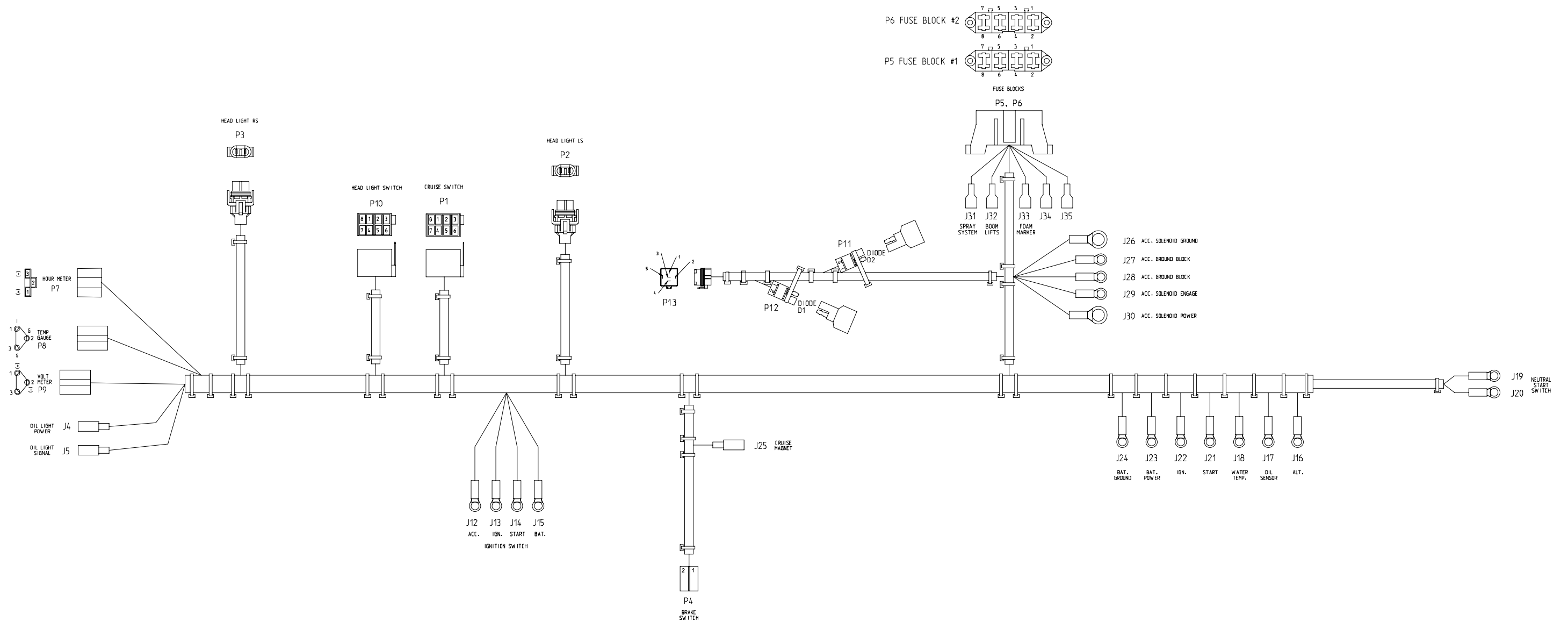

Multi Pro 5600  
**Vehicle Wire Harness**  
 (Serial Numbers 230000400 and above)

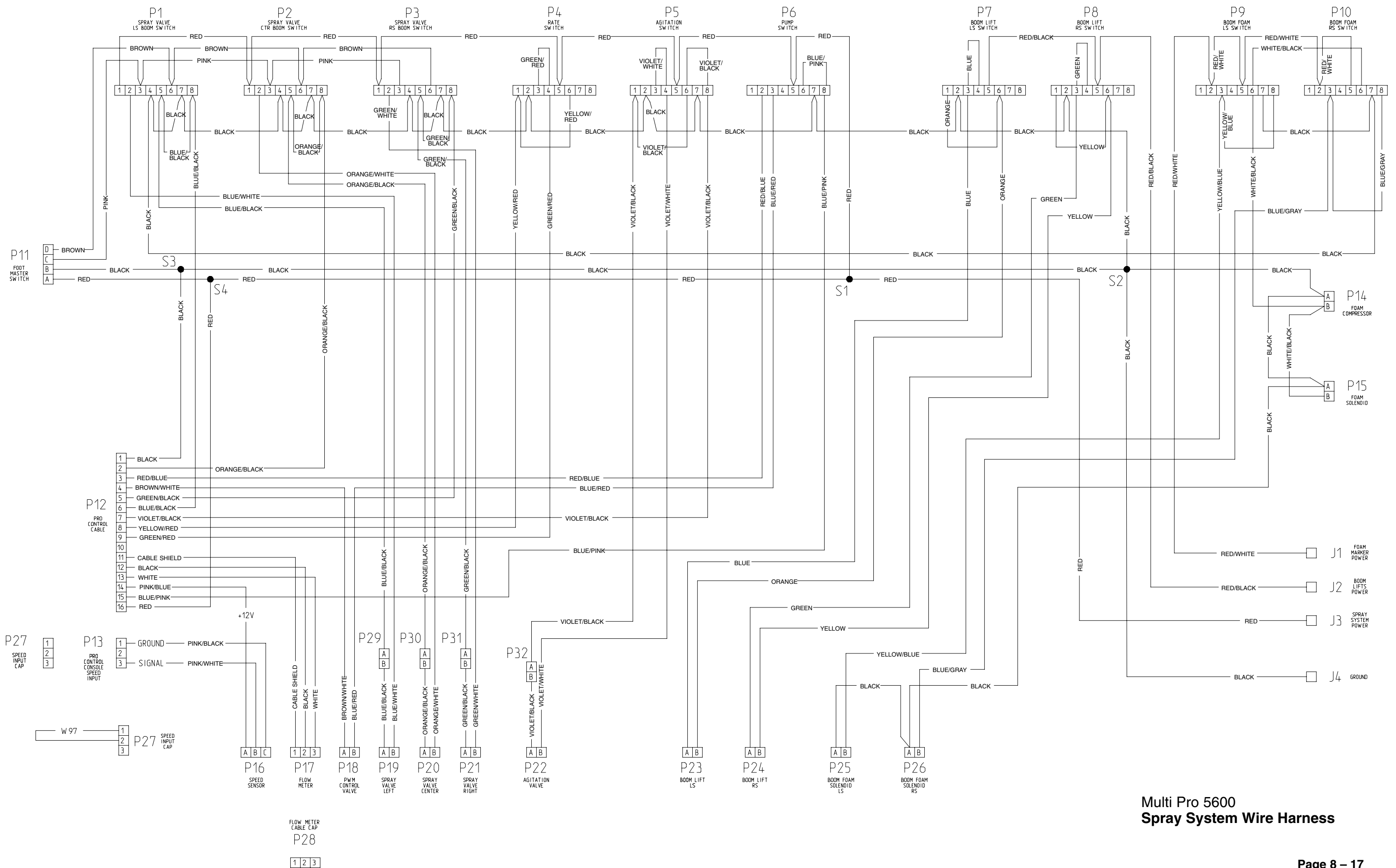

**Multi Pro 5600  
Spray System Wire Harness**

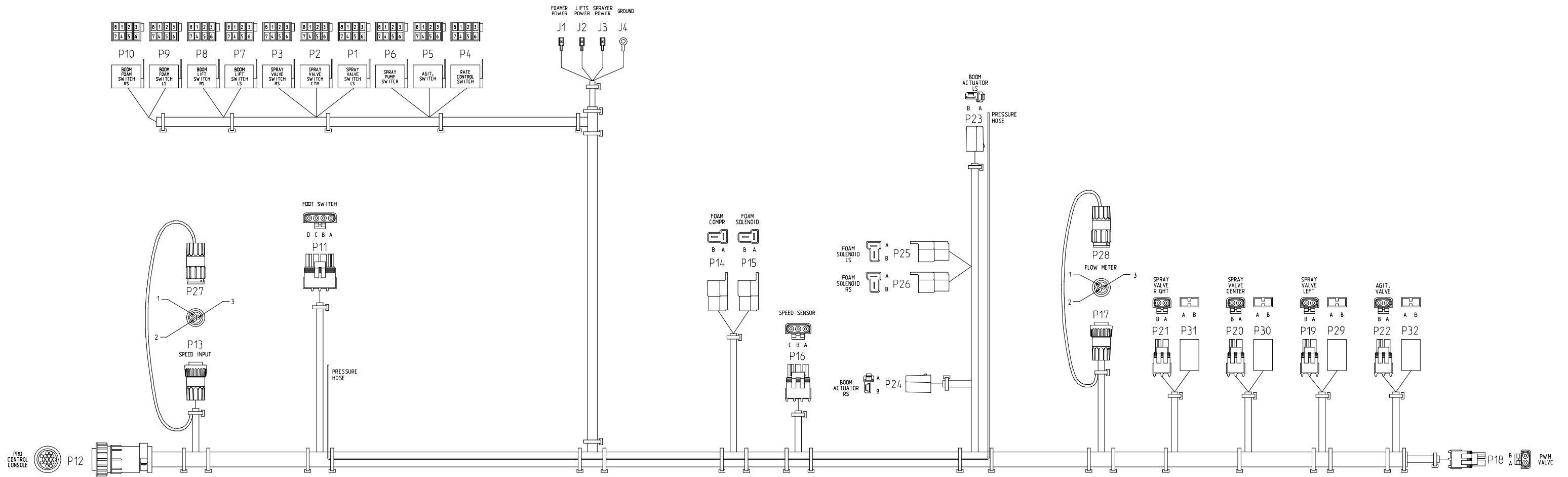

Multi Pro 5600  
Spray System Wire Harness