



Kubota-Powered Z Master® Mowers

Setup Instructions

Loose Parts

Use the chart below to verify that all parts have been shipped.

Procedure	Description	Qty.	Use
1	No parts required	–	Unfold the crate.
2	No parts required	–	Check the tire pressure.
3	Bolt, (3/8 x 1 inch) Flange nut, (3/8 inch) Curved washer	8 8 8	Install the Roll Over Protection System (ROPS)
4	No parts required	–	Add fuel to the machine.
5	No parts required	–	Charge the battery.
6	Number 2 general purpose lithium base or molybdenum base grease. (Purchase separately.)	1 tube	Check the machine for grease.
7	No parts required	–	Check the engine oil level.
8	No parts required	–	Prepare the side discharge chute.
9	No parts required	–	Check the machine before delivery to the customer.
10	Operator's Manual Engine Owner's Manual Registration Card Operator training material Key	1 1 1 1 2	Delivering the machine to the customer.

1

Unfolding the Crate

No Parts Required

Procedure

Refer to the Packaging Crate Instructions included with the machine.

2

Checking the Tire Pressure

No Parts Required

Procedure

Pressure: 13 psi (90 kPa)

Note: The front caster wheels are semi-pneumatic tires and do not need to be checked.

Check the air pressure in the drive tires.

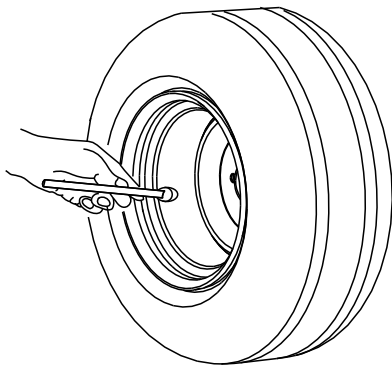

G001055

Figure 1

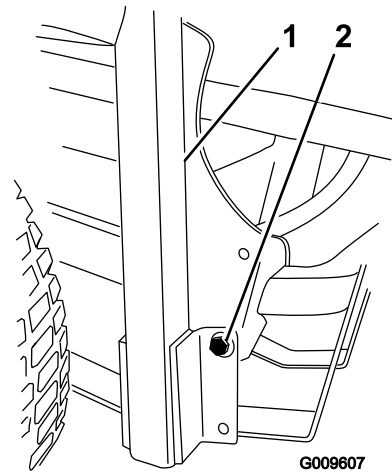

G009607

Figure 2

1. Roll Over Protection System (ROPS)
2. Remove this hardware and discard it

2. Install the ROPS to the frame on both sides with 8 bolts (3/8 x 1 inch), 8 curved washers, and 8 flange nuts (3/8 inch) (Figure 3).

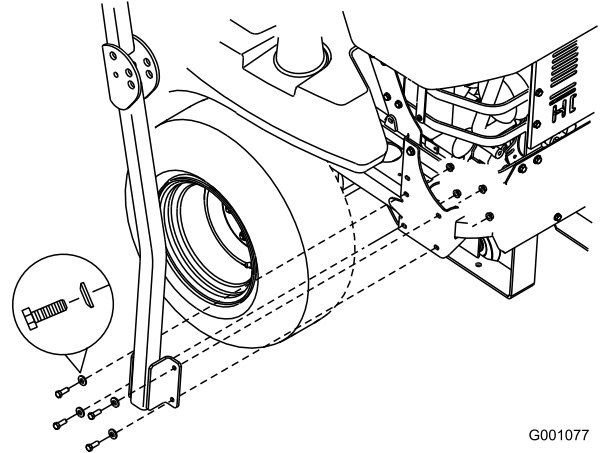

G001077

Figure 3

3

Installing the Roll Over Protection System (ROPS)

Parts needed for this procedure:

8	Bolt, (3/8 x 1 inch)
8	Flange nut, (3/8 inch)
8	Curved washer

Procedure

The Roll Over Protection System (ROPS) is not installed in the correct position for shipping purposes.

1. Remove the hardware holding the ROPS to the machine and discard this hardware (Figure 2).

4

Adding Fuel to the Machine

No Parts Required

Procedure

Add fuel to the machine before starting it. Refer to your *Operator's Manual*. for the correct fuel and procedure.

5

Charging the Battery

No Parts Required

Procedure



Charging the battery produces gasses that can explode and cause serious injury.

- Keep cigarettes, sparks and flames away from the battery.
- Make sure the ignition switch is off.
- Ventilate when charging or using the battery in an enclosed space.

Important: Do not run the machine with the battery disconnected; electrical damage may occur to the engine.

Charge the battery. Refer to the *Operator's Manual* for instructions.

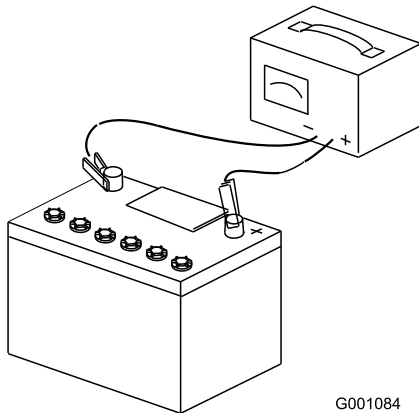

G001084

Figure 4

6

Checking the Machine for Grease

Parts needed for this procedure:

1 tube	Number 2 general purpose lithium base or molybdenum base grease. (Purchase separately.)
--------	---

Procedure

1. Remove the belt covers as shown below.

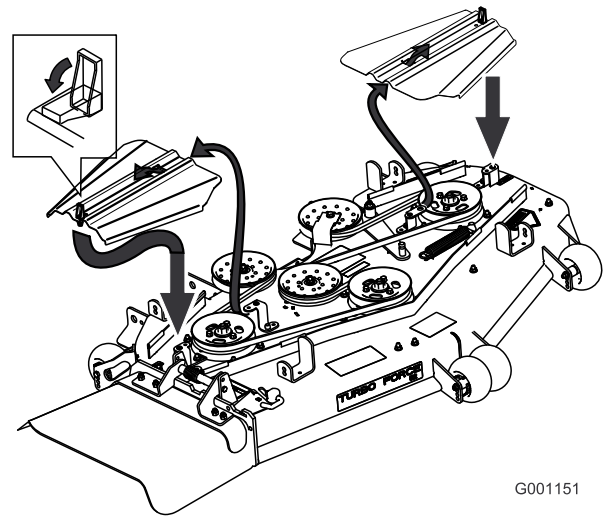

G001151

Figure 5

2. Check the tensioning arm for grease.
3. Check the grease for the three spindle bearings. If needed, add grease until it comes out of the lower seals.
4. Install the belt covers.

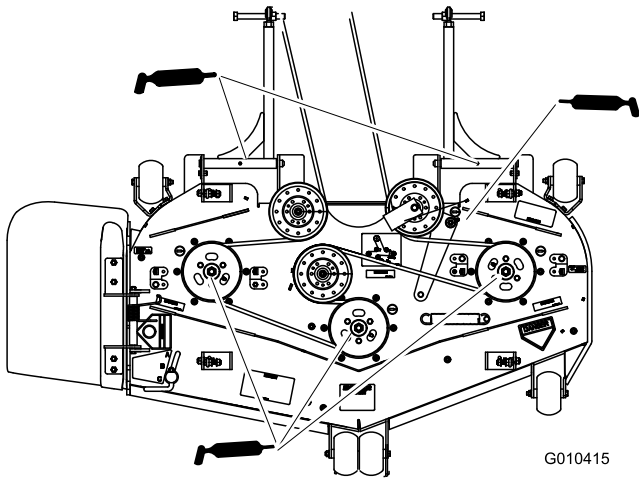

Figure 6

8

Checking the Side Discharge Chute

No Parts Required

Procedure

If there are plastic ties holding the side discharge chute up, remove them and lower the chute into place.

5. Check the grease for the pump drive belt idler arm.
6. Check the grease for the PTO drive belt idler arm.

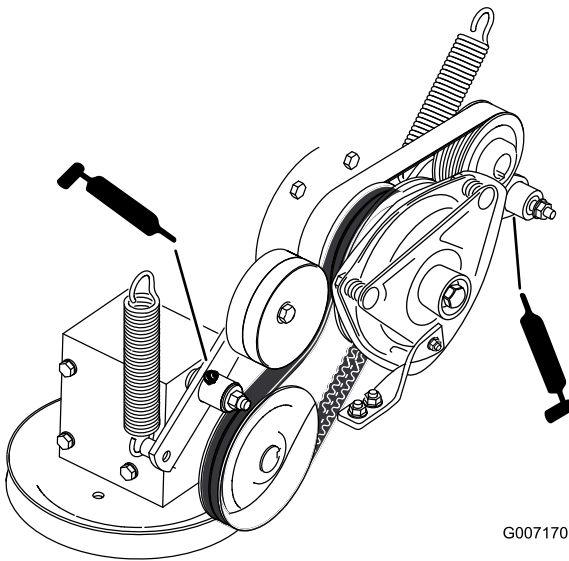

Figure 7



An uncovered discharge opening could allow the lawn mower to throw objects in the operator's or bystander's direction and result in serious injury or death. Also, contact with the blade could occur.

Never operate the lawn mower with the grass deflector removed unless you install a cover plate, a mulch plate, or a grass chute and catcher.

1. Make sure the **L** end of spring is installed behind the deck edge before installing the bolt as shown in Figure 8.
2. Place the **J** hook end of spring around grass deflector (Figure 8).

Important: The grass deflector must be free to rotate with downward tension. Lift the deflector up to the full open position and ensure that it rotates freely, without binding into the full down position.

7

Checking the Engine Oil Level

No Parts Required

Procedure

Before you start the engine and use the machine, check the oil level in the engine crankcase; refer to Checking Oil Level in *Operator's Manual*.

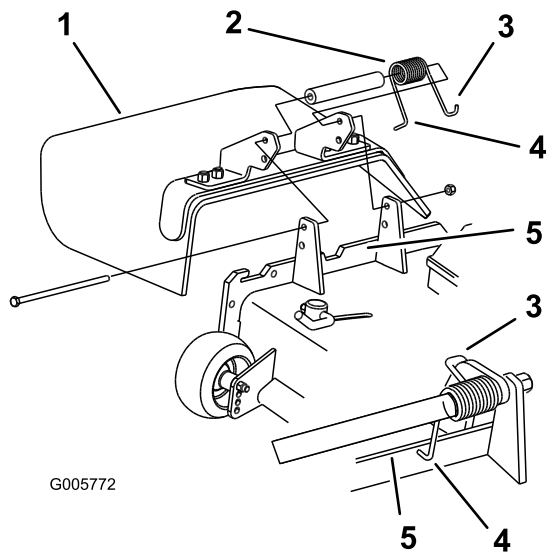

G005772

Figure 8

- 1. Grass Deflector
 - 2. Spring
 - 3. J hook end of spring
 - 4. L end of spring, place behind deck edge before installing bolt
 - 5. Deck edge
-

9

Checking the Machine Before Delivery to the Customer

No Parts Required

Procedure

Before delivering the machine to the customer, ensure that you perform or have performed the procedures listed in the following table and initial each when finished. Refer to the Operator's Manual for instructions on performing these procedures.

Initial	Check Procedure
	Check the tire pressure.
	Check the level of the mower.
	Check that all mower spindles are greased.
	Check the engine oil level.
	Check the hydraulic fluid level.
	Check ROPS is secure.
	On liquid cooled machines, check the level of the coolant in the radiator and overflow bottle.
	Check the adjustment of the parking brake.
	Ensure that the machine tracks correctly; refer to the <i>Operator's Manual</i> for the adjustment procedure.
	Check the safety interlock system; refer to the <i>Operator's Manual</i> .
	Ensure that the PTO works.
	Check all fasteners you installed to ensure that they are tight.

When you finish setting up the machine, sign and date in the space provided below:

Signature: _____ **Date:** _____

10

Delivering the Machine to the Customer

Parts needed for this procedure:

1	<i>Operator's Manual</i>
1	<i>Engine Owner's Manual</i>
1	Registration Card
1	Operator training material
2	Key

Procedure

At delivery, Fill in the model and serial number and complete the items listed in the following table and initial each when finished.

Model No. _____ **Serial No.** _____

Dealer Initial	Customer Initial	Check Procedure
		Show the customer where the following features are located and how they function: Fuel tank caps Oil fill cap/ Oil dipstick Engine oil filter Engine oil drain Fuel filters Air filter Radiator coolant Hydraulic fluid reservoir Hydraulic filter Battery Ignition switch Throttle lever Glow plug light and switch Power take off switch (PTO) Motion control levers Parking brake Mower height-of-cut Lift assist lever Z Stand® (Only on International machines) Adjustable seat Hydraulic bypass valves Rollover Protection System (ROPS) Mower deck flow baffle
		Refer to the <i>Operator's Manual</i> to point out safety procedures, operation, and maintenance procedures.
		Review the warranty statement as shown in the <i>Operator's Manual</i> .
		Describe the post sale service procedures for your store.
		Assist the customer in filling out and mailing the registration card or register online at www.Toro.com
		Make sure that the customer receives the <i>Operator's Manual</i> , <i>Engine Owner's Manual</i> , <i>Set Up Instructions</i> , and operator training material.
		Make sure the customer knows the <i>Parts Catalog</i> is available at www.Toro.com
		Assist the customer in loading the mower.

Note: When you, the dealer representative, have finished delivering the machine to the customer, sign and date in the space provide below and keep a copy of this page for dealer records.

Signature: _____ **Date:** _____

Signature: _____ **Date:** _____