



Operator-Controlled Discharge Chute Kit Commercial Walk-Behind Mower with 48in, 52in or 60in Cutting Unit

Model No. 115-4195

Parts Catalog

Ordering Replacement Parts

To order replacement parts, please supply the part number, the quantity, and the description of each part desired.

Understanding Reference Numbers

Each identified part in an illustration has a reference number. The reference number for a part also appears in the parts list, along with other information about the part.

This catalog uses two special reference number formats, one to indicate parts in a service assembly and another to indicate the quantity of a given part in an illustration.

Service Assembly Reference Numbers

Parts in service assemblies have reference numbers in the form a:b. The a represents the reference number of the entire service assembly and the b represents a sequential number unique to each part within the service assembly.

For example, a wheel assembly might be identified by reference number 6, the tire by 6:1, the valve by 6:2, and the wheel by 6:3. When you order the assembly identified by reference number 6, you receive all parts identified by reference numbers 6:1, 6:2, and 6:3. However, you may also order any part individually. Reference numbers of this type appear in illustrations and in part lists.

Reference Numbers Indicating Quantity

In an illustration, if a reference number indicates more than one part, the reference number has the form nX y. The n represents the quantity of the part, the X is the multiplication symbol, and the y represents the reference number.

For example, in an illustration, the reference number 2X 37 means that two of the parts identified by reference number 37 are indicated.

Contents

Description	Page	Description	Page
Chute Gate Assembly No. 115-4195 3	Door Assembly No. 117-0471 5
Deflector Assembly No. 115-4165 4		

Part Description Abbreviations

Part descriptions in this catalog may include the following abbreviations.

AR. as required	HYD. hydraulic
ASM. assembly	LH. left hand
BBC. blade brake clutch	NI. nylon insert
CARR. carriage	NPTF. national pipe thread fine
DEG. degrees	PFH. phillips flat head
EXT. external	PPH. phillips pan head
FH. flat head	PPHTF. phillips pan head thread forming
GA. gauge	PRH. phillips round head
HD. heavy-duty	PTH. phillips truss head
HF. hex flange	PTO. power-take-off
HH. hex head	RH. right hand
HHF. hex head flange	ROPS. roll-over protection system
HHFTF. hex head flange thread forming	SFH. slotted fillister head
HJ. hex jam	SHH. slotted hex head
HLH. hex lag head	SHWH. slotted hex washer head
HOC. height-of-cut	SPH. slotted pan head
HSBH. hex socket button head	SQH. square head
HSFH. hex socket flat head	SRH. slotted round head
HSH. hex socket head	STD. standard
HWH. hex washer head	TAP. self tapping
HWHTF. hex washer head thread forming	TTH. torx truss head

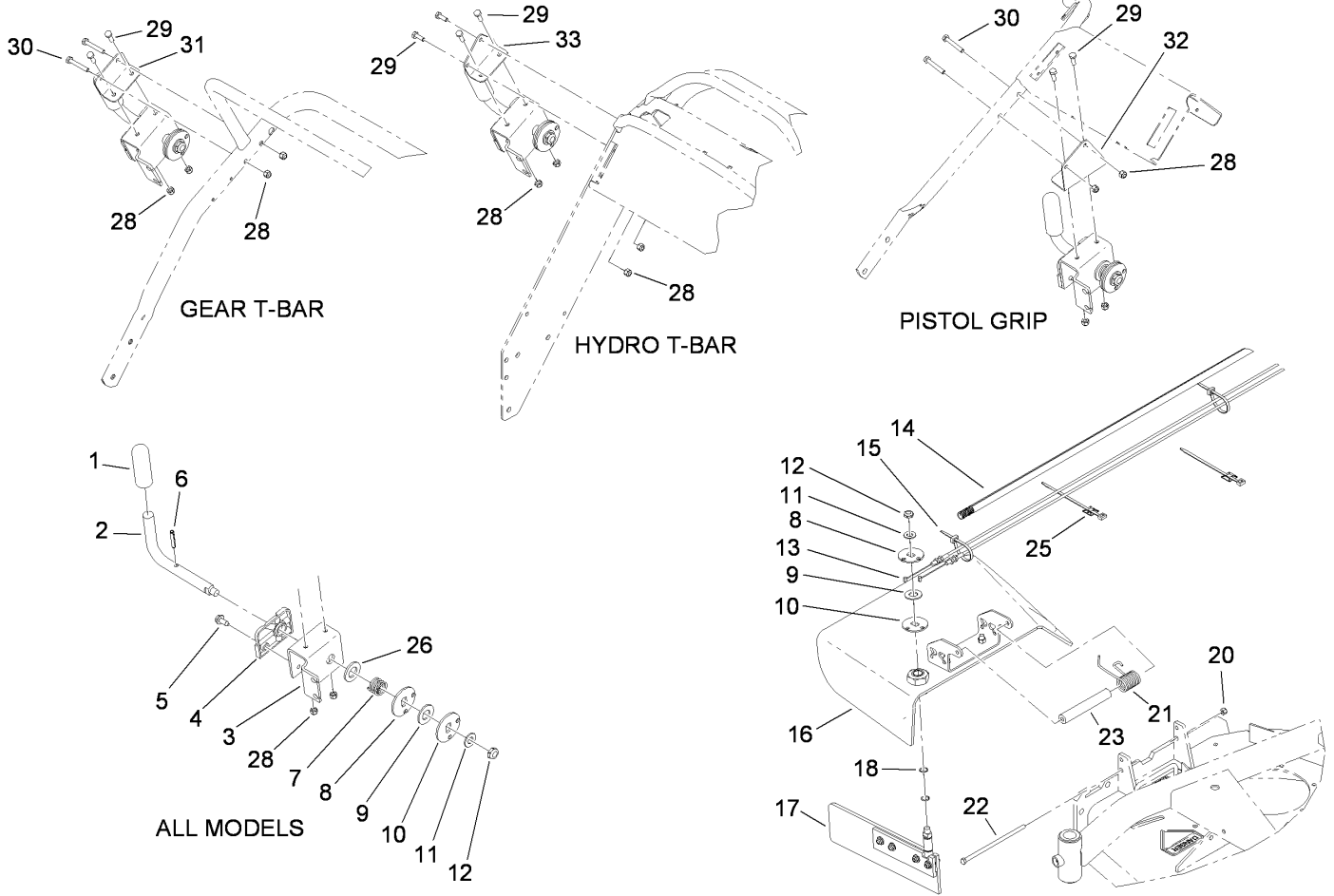

Chute Gate Assembly No. 115-4195

Ref	Part No.	Qty.	Description
1	108-7221	1	Grip
2	112-7096	1	Lever
3	112-7095-03	1	Bracket-Lever
4	108-2231	1	Block-Detent
5	32144-70	1	Screw-HWHTF
6	32121-15	1	Pin-Roll
7	87-3660	1	Spring-Compression
8	108-7218	2	Pulley-Top
9	108-7217	2	Pulley-Middle
10	108-7216	2	Pulley-Bottom
11	3256-26	2	Washer-Flat
12	3296-45	2	Nut-Lock, NI
13	115-4176	2	Cable
14	115-4169	1	Tube-Convolutd
15	3290-378	4	Tie-Cable
16	115-4165	1	Deflector ASM
17	117-0471	1	Door ASM
18	237-65	2	O-Ring
20	3296-29	1	Nut-Lock, NI
21	104-8554	1	Spring-Torsion
22	322-50	1	Screw-HH
23	105-4622	1	Spacer
25	93-3922	2	Mount-Tie, Cable
26	3256-28	1	Washer-Flat

Ref	Part No.	Qty.	Description
28	3296-42	4	Nut-Lock, NI
29	321-4	4	Screw-HH
30	321-10	2	Screw-HH
31	115-4157-03	1	Bracket-Mounting, T-Bar (Gear)
32	115-4158-03	1	Bracket-Mounting, Pistol Grip
33	115-4159-03	1	Bracket-Mounting, T-Bar (Hydro)

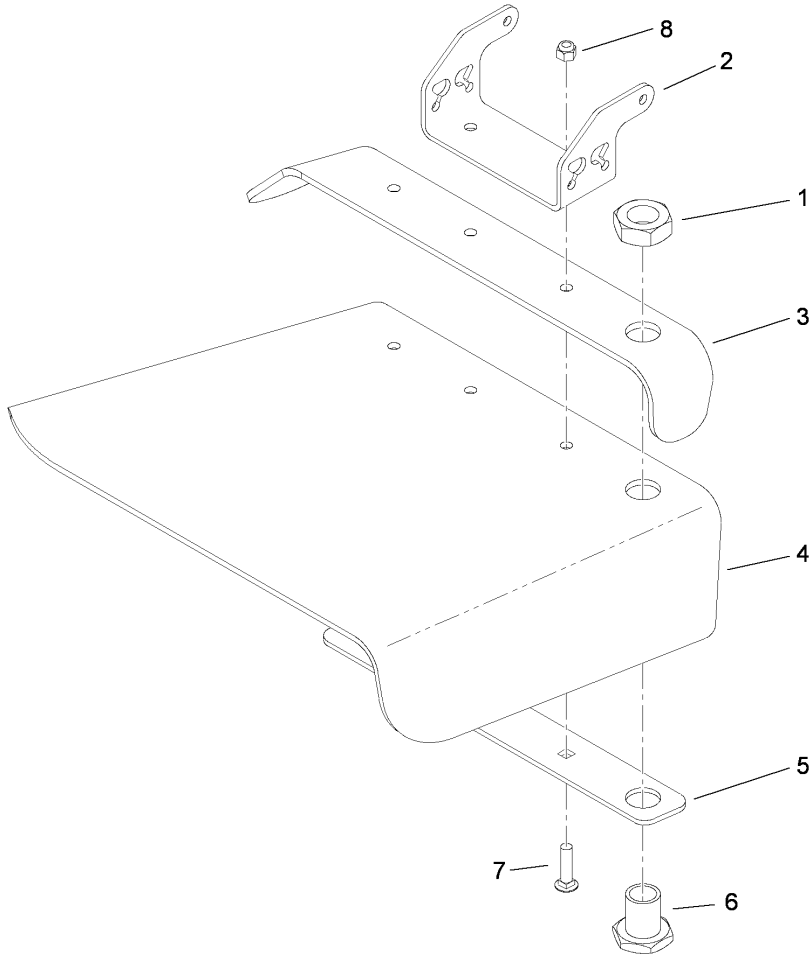

Deflector Assembly No. 115-4165

Ref	Part No.	Qty.	Description
1	67-5840	1	Nut-Jam
2	115-4161-01	1	Hinge-Deflector
3	115-4167-01	1	Bracket-Deflector
4	115-4166	1	Deflector-Rubber
5	115-4168-03	1	Strap-Deflector
6	108-7215	1	Hub ASM
7	3231-4	3	Screw-CARR
8	3296-39	3	Nut-Lock, NI

--	--	--	--

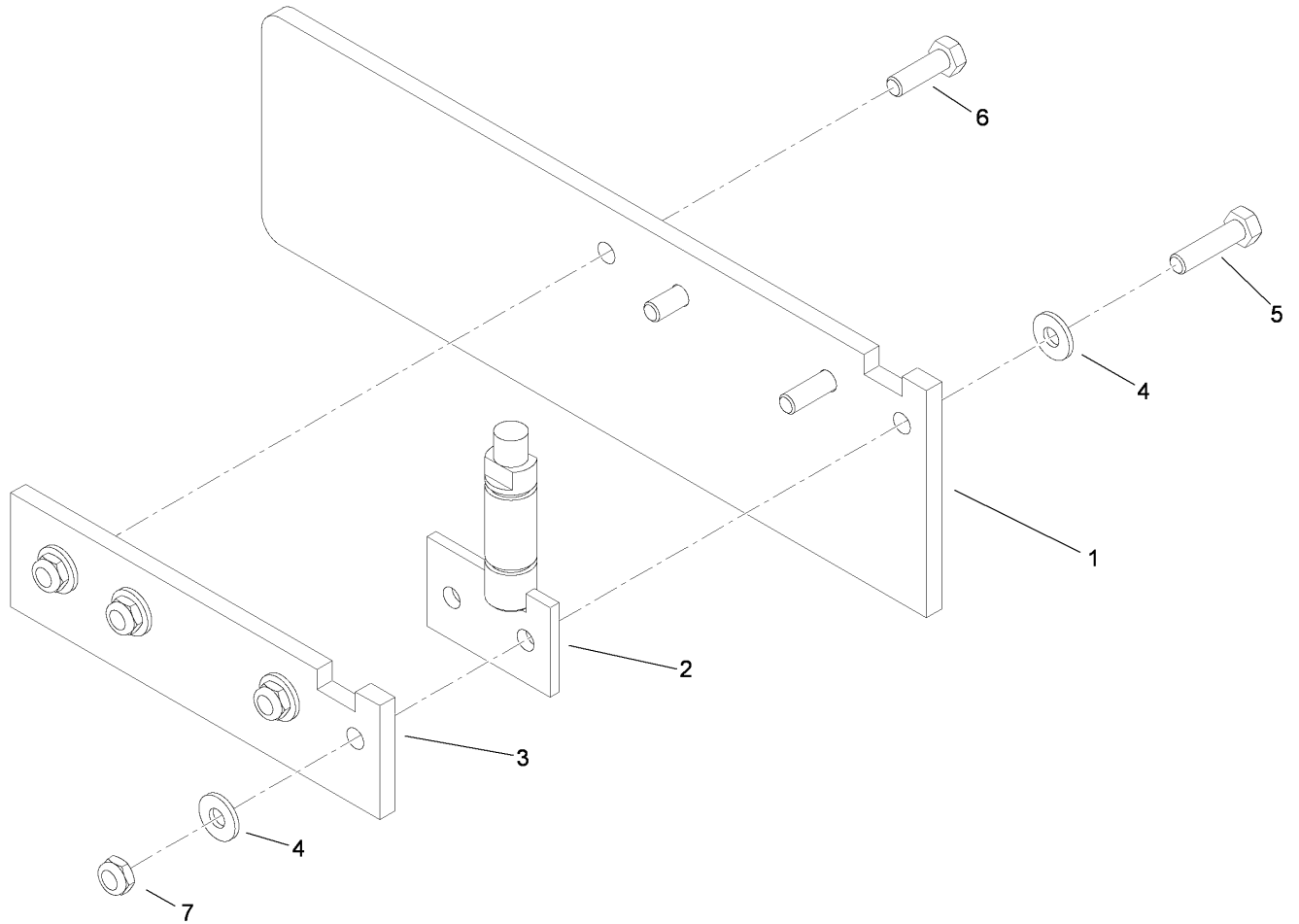

Door Assembly No. 117-0471

Ref	Part No.	Qty.	Description
1	117-0472	1	Gate-Chute, Rubber
2	107-8505	1	Hinge-Gate
3	108-7219	1	Door-Support
4	3256-2	8	Washer-Flat
5	322-6	2	Screw-HH
6	322-5	2	Screw-HH
7	3296-47	4	Nut-Lock, NI

NOTES

NOTES

