



## Workman<sup>®</sup> MDE Utility Vehicle

Model No. 07299 - 290000001 and up.

### Parts Catalog

---

#### **Ordering Replacement Parts**

To order replacement parts, please supply the part number, the quantity, and the description of each part desired.

#### **Understanding Reference Numbers**

Each identified part in an illustration has a reference number. The reference number for a part also appears in the parts list, along with other information about the part.

This catalog uses two special reference number formats, one to indicate parts in a service assembly and another to indicate the quantity of a given part in an illustration.

#### **Service Assembly Reference Numbers**

Parts in service assemblies have reference numbers in the form a:b. The a represents the reference number of the entire service assembly and the b represents a sequential number unique to each part within the service assembly.

For example, a wheel assembly might be identified by reference number 6, the tire by 6:1, the valve by 6:2, and the wheel by 6:3. When you order the assembly identified by reference number 6, you receive all parts identified by reference numbers 6:1, 6:2, and 6:3. However, you may also order any part individually. Reference numbers of this type appear in illustrations and in part lists.

#### **Reference Numbers Indicating Quantity**

In an illustration, if a reference number indicates more than one part, the reference number has the form nX y. The n represents the quantity of the part, the X is the multiplication symbol, and the y represents the reference number.

For example, in an illustration, the reference number 2X 37 means that two of the parts identified by reference number 37 are indicated.

# Contents

Description	Page	Description	Page
Dash Assembly	..... 3	Battery and Transaxle Assembly	..... 13
Solenoid Assembly No. 104-7135	..... 4	Electric Motor Assembly No. 104-7335	..... 14
Pedal Box Assembly	..... 5	Electric Transaxle Assembly No. 114-8330	..... 15
Master Cylinder and Brake Line Assembly	..... 6	LH Rear Brake Assembly No. 114-8332	..... 16
Master Cylinder Assembly No. 104-6782	..... 7	RH Rear Brake Assembly No. 114-8331	..... 17
Frame Assembly	..... 8	Upper Steering Assembly	..... 18
Seat Base Assembly	..... 9	Steering Box Assembly No. 112-3130	..... 19
Offboard 48 Volt Charger Assembly No. 112-3072	..... 10	Box and Tailgate Installation Assembly	..... 20
Front Tire, Spindle and Tie Rod Assembly	..... 11	Box and Tailgate Assembly	..... 21
Controller Assembly	..... 12	Hood and Fender Assembly	..... 22
		Attachments and Accessories List	..... 23

## Part Description Abbreviations

Part descriptions in this catalog may include the following abbreviations.

AR. .... as required	HYD. .... hydraulic
ASM. .... assembly	LH. .... left hand
BBC. .... blade brake clutch	NI. .... nylon insert
CARR. .... carriage	NPTF. .... national pipe thread fine
DEG. .... degrees	PFH. .... phillips flat head
EXT. .... external	PPH. .... phillips pan head
FH. .... flat head	PPHTF. .... phillips pan head thread forming
GA. .... gauge	PRH. .... phillips round head
HD. .... heavy-duty	PTH. .... phillips truss head
HF. .... hex flange	PTO. .... power-take-off
HH. .... hex head	RH. .... right hand
HHF. .... hex head flange	ROPS. .... roll-over protection system
HHFTF. .... hex head flange thread forming	SFH. .... slotted fillister head
HJ. .... hex jam	SHH. .... slotted hex head
HLH. .... hex lag head	SHWH. .... slotted hex washer head
HOC. .... height-of-cut	SPH. .... slotted pan head
HSBH. .... hex socket button head	SQH. .... square head
HSFH. .... hex socket flat head	SRH. .... slotted round head
HSH. .... hex socket head	STD. .... standard
HWH. .... hex washer head	TAP. .... self tapping
HWHTF. .... hex washer head thread forming	TTH. .... torx truss head

## Footnotes

- ❶ Not serviced separately

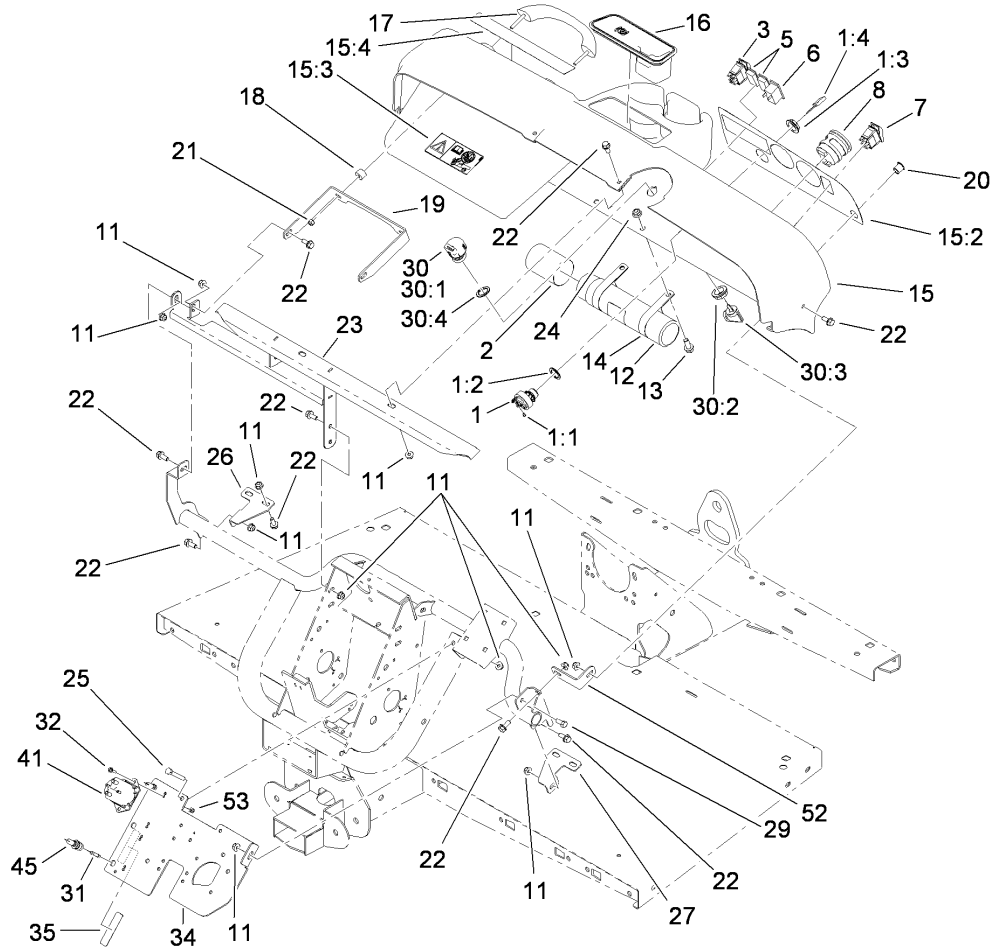

## Dash Assembly

Ref	Part No.	Qty.	Description
1	107-0348	1	Switch-Key, 48V
1:1	3250-28	3	Screw
1:2	108-8659	1	Washer-Backup
1:3	108-8660	1	Nut-Mounting
1:4	108-6994	1	Key-Ignition
2	104-7048	1	Cap-Housing
3	107-0255	1	Switch
5	99-7420	2	Plug-Hole
6	104-7129	1	Light-Indicator
7	107-0747	1	Switch-Rocker
8	107-0260	1	Guage-Hour/Battery Level, 48 Volt
11	104-8300	18	Nut-Flange, NI
12	104-7050	1	Housing-Manual
13	3234-11	2	Screw-HHF
14	2412-133	2	R-Clamp
15	114-8311	1	Dash ASM
15:2	112-3310	1	Decal-Dash, Ce
15:3	104-7215	1	Decal-Danger
15:4	115-2412	1	Decal-No Storage
16	104-6930	1	Plug-Rubber
17	112-3320	1	Handle-Grip
18	114-8301	2	Spacer
19	112-3391-03	1	Bracket-Grip, Handle
20	94-5627	1	Plug

Ref	Part No.	Qty.	Description
21	104-7201	2	Nut-HF
22	110-5053	15	Screw-Flange
23	115-7651-03	1	Dash Support ASM
24	104-8301	2	Nut-Flange, NI
25	322-11	2	Screw-HH
26	114-8304	1	Bracket-Dash Mount, RH
27	114-8312	1	Bracket-Dash Mount, LH
29	322-3	1	Screw-HH
30	110-2580	1	Switch-Key, Supervisor
● 30:1		1	Switch-Key
30:2	108-8660	1	Nut-Mounting
30:3	110-5221	1	Set-Key, Supervisor
30:4	108-8659	1	Washer-Backup
31	98-8876	2	Fuse-10 Amp
32	32105-13	2	Screw-HWH
34	112-3376-03	1	Plate-Mount, Electrical
35	115-7621	1	Decal-Electrical
41	104-7135	1	Solenoid
45	218-489	2	Holder-Fuse
52	114-8305	1	Angle-Mount, Dash (LH)
53	3296-2	2	Nut-Lock

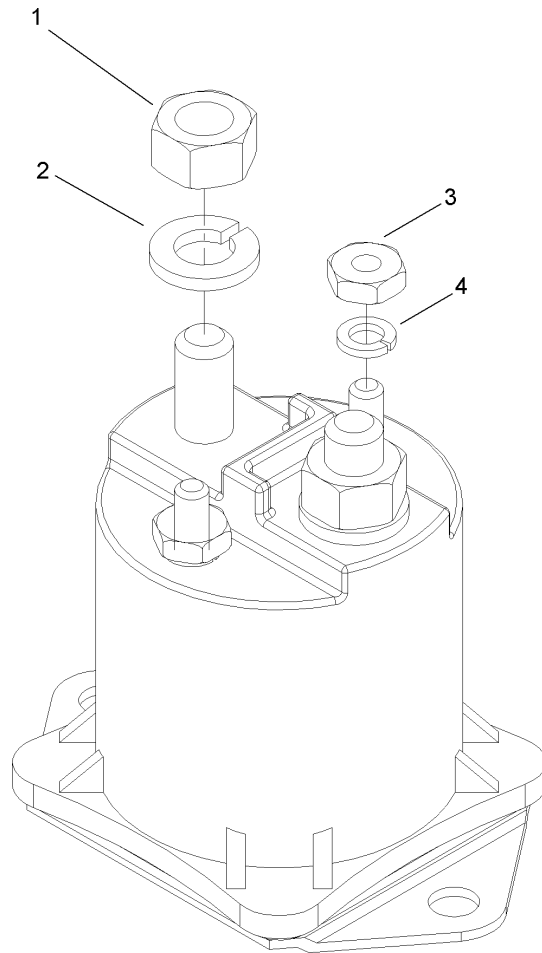

### Solenoid Assembly No. 104-7135

Ref	Part No.	Qty.	Description				
1	3217-6	2	Nut-Hex				
2	3253-4	2	Washer-Lock				
3	3219-14	2	Nut-Hex				
4	3253-17	2	Washer-Lock				

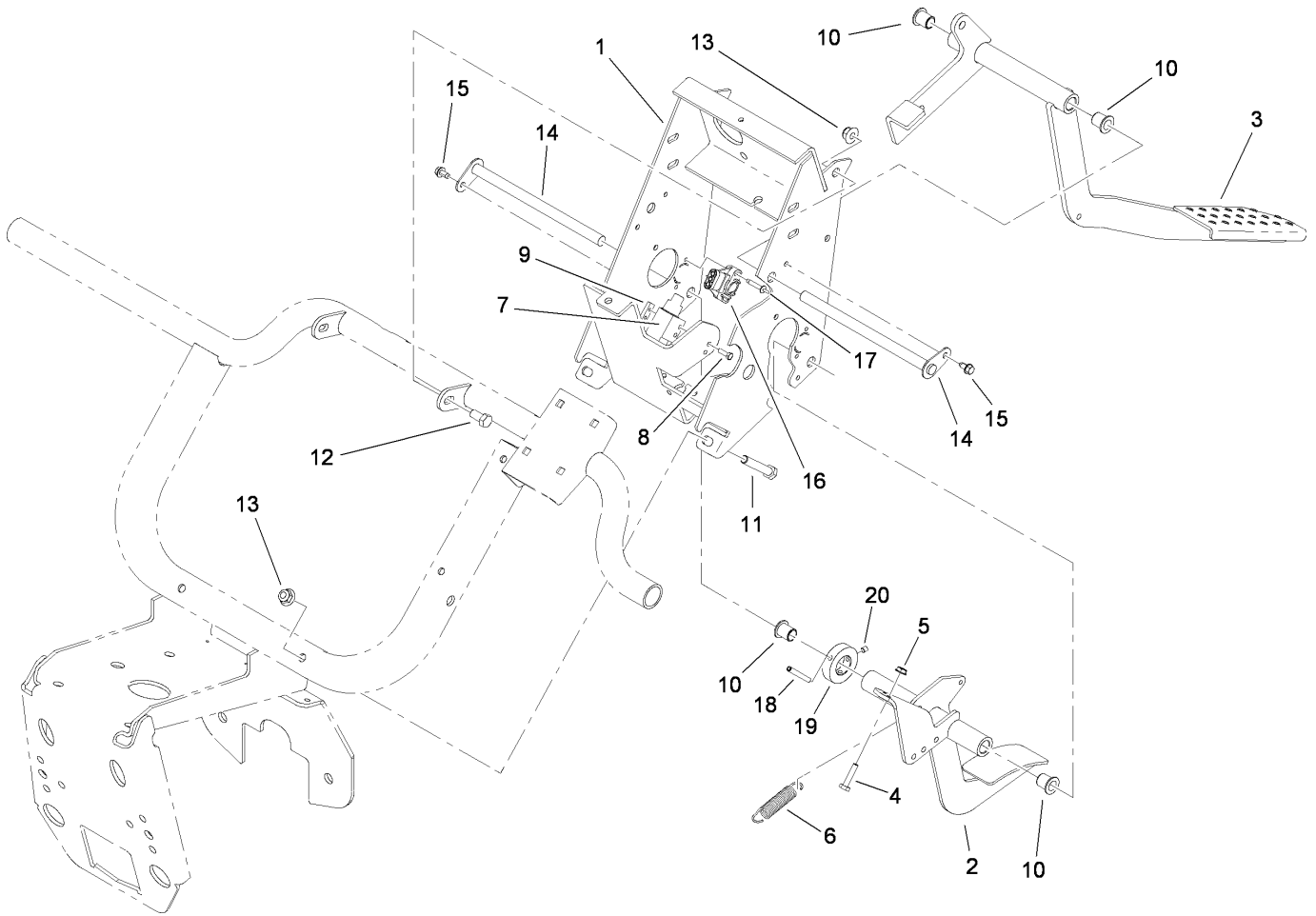

## Pedal Box Assembly

Ref	Part No.	Qty.	Description
1	112-3317-03	1	Pedal Support Frame ASM
2	115-7630-03	1	Throttle Pedal ASM
3	112-3314-03	1	Brake Pedal ASM
4	321-7	2	Screw-HH
5	32149-2	2	Nut-Keps
6	104-6415	1	Spring-Return, Pedal
7	99-7407	1	Switch
8	3290-134	2	Screw
9	1-633181	1	Plate-Tapped
10	256-155	4	Bushing-Flange
11	323-11	2	Screw-HH
12	323-4	2	Screw-HH
13	104-8301	4	Nut-Flange, NI
14	104-7164	2	Pivot-Pedal
15	12-3270	2	Screw
16	112-3046	1	Sensor-Position, Rotary
17	107-0386	2	Rivet-Blind
18	32121-78	1	Pin-Roll
19	104-7301	1	Collar
20	3245-32	2	Screw-HSH

--	--	--	--





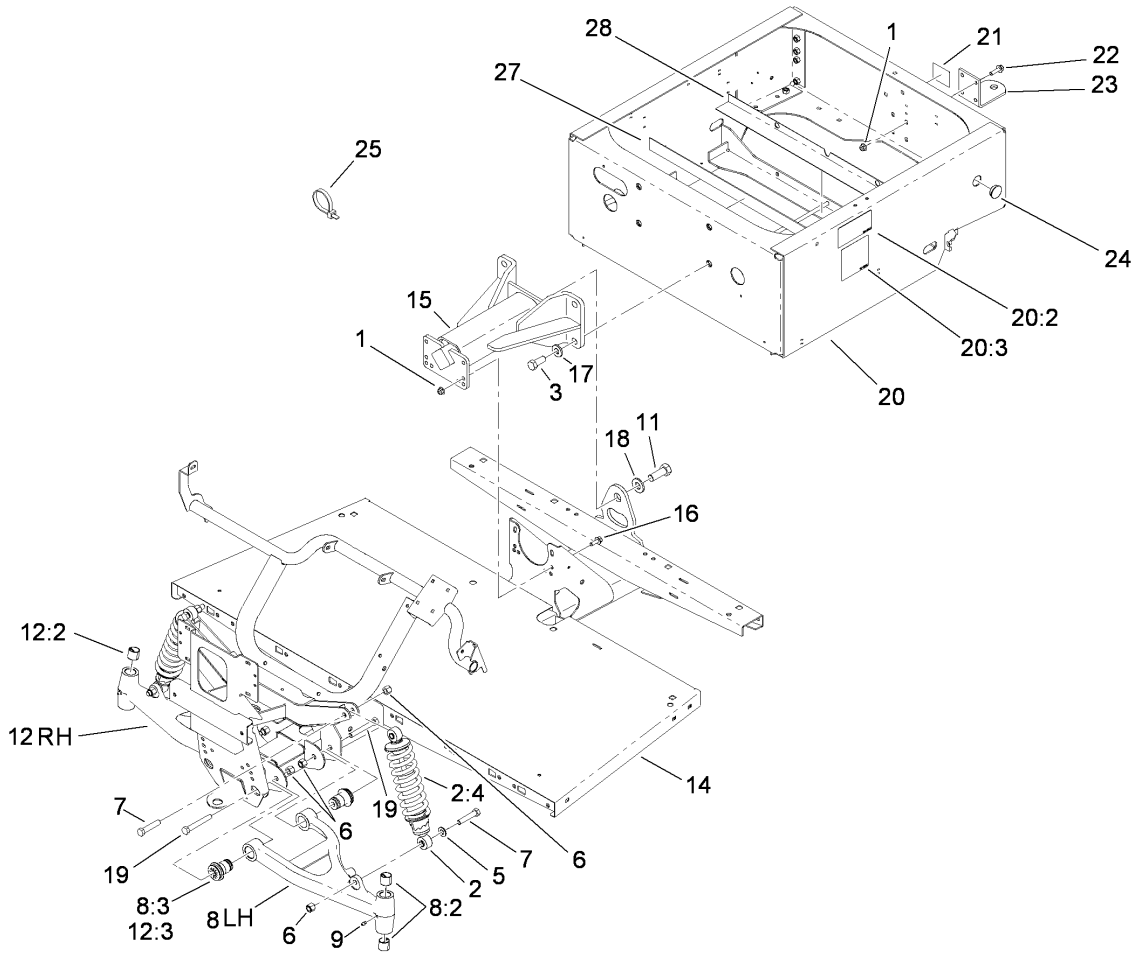

### Frame Assembly

Ref	Part No.	Qty.	Description
1	104-8301	8	Nut-Flange, NI
2	112-2975	2	Shock/Spring ASM
2:4	112-3383	1	Spring
3	327-4	4	Screw-HH
5	3256-26	2	Washer-Flat
6	3296-23	8	Nut-Lock, NI
7	325-10	4	Screw-HH
8	114-8313	1	LH A-Arm ASM
8:2	3-0348	2	Bushing
8:3	87-1450	2	Bushing-Flange
9	302-5	2	Fitting-Grease
11	328-24	1	Screw-HH
12	114-8314	1	RH A-Arm ASM
12:2	3-0348	2	Bushing
12:3	87-1450	2	Bushing-Flange
14	112-3340-03	1	Front Frame ASM
15	99-7700	1	Pivot Yoke ASM
16	3234-11	4	Screw-HHF
17	99-7667	4	Washer-Flat
18	87-3060	1	Washer-Hardened
19	325-14	4	Screw-HH
20	112-3018	1	Rear Frame ASM
20:2	104-7207	2	Decal-Electric
20:3	107-0257	1	Decal-Polarity

Ref	Part No.	Qty.	Description
21	99-7350	1	Decal-Rating, Hitch (Light Duty)
22	3234-24	4	Screw-HHF
23	99-7654-03	1	Hitch-Duty, Light
24	94-1402	1	Plug-Hole
25	3290-379	15	Tie-Cable
27	107-0252	1	Pad-Battery
28	107-0267	4	Isolator-Battery



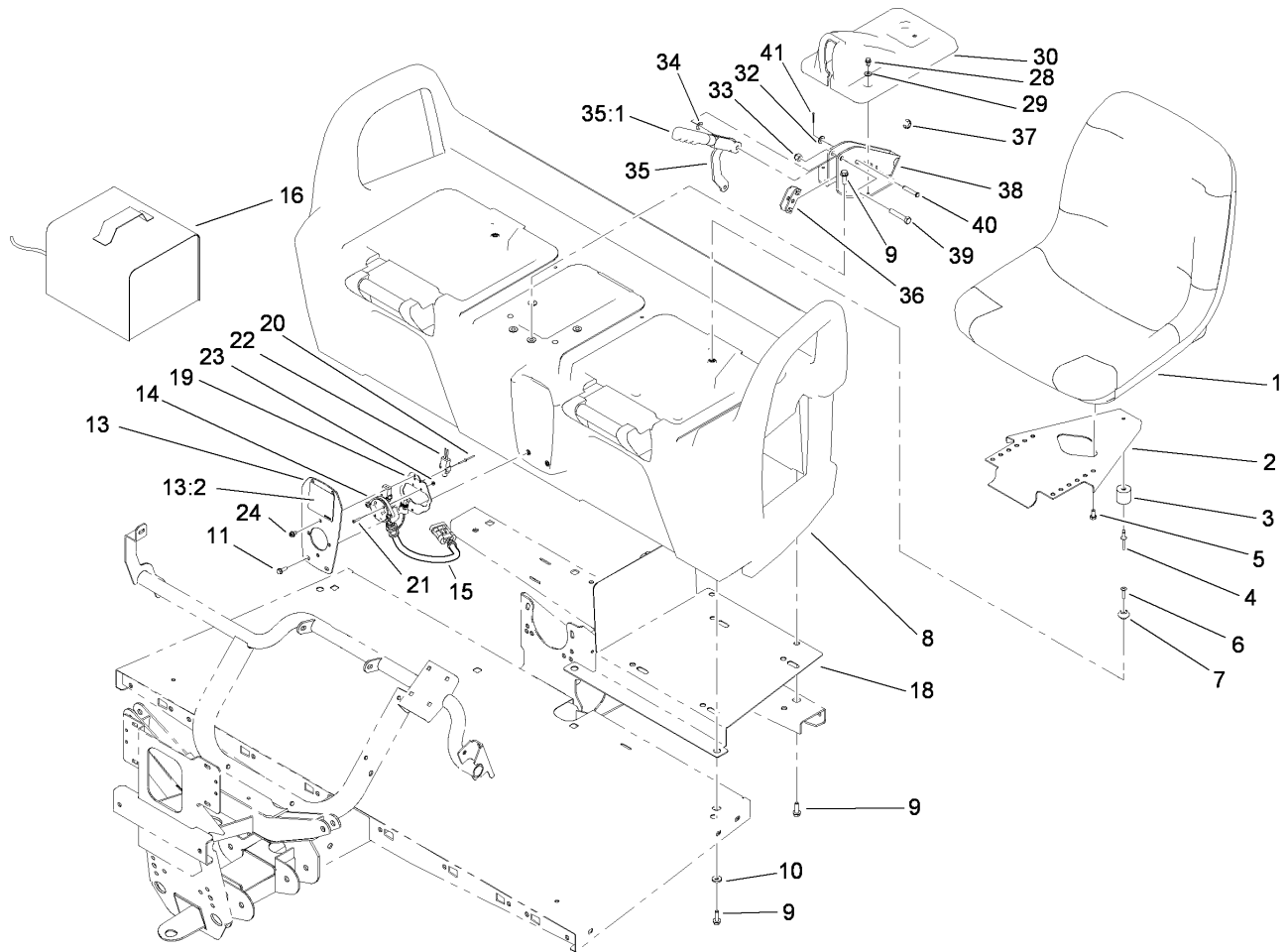

## Seat Base Assembly

Ref	Part No.	Qty.	Description
1	112-2923	2	Seat ASM
2	99-7829	2	Bracket-Seat
3	99-7830	2	Rubber Receptical ASM
4	3290-412	2	Rivet
5	33114-016	8	Screw-HH
6	32108-5	2	Screw-FH
7	99-7833	2	Post-Holding
8	104-6847	1	Seat Base ASM
9	3234-17	12	Screw-HHF
10	88-7200	8	Washer-Flat
11	32105-15	4	Screw
13	107-0370	1	Plate-Receptacle
13:2	107-0295	1	Decal-Charger
14	107-0288	1	Receptacle-Charger
15	115-1913	1	Harness-Wire, Charger
16	112-3072	1	Charger-48V T145, Offboard
18	107-0359-03	1	Tray-Seatbase
19	107-0716	1	Bracket-Mount, Socket
20	107-0333	2	Rivet-Pop
21	107-0334	2	Screw-HSH
22	99-3410	1	Switch
23	3296-9	2	Nut-Lock
24	32104-17	4	Screw-HWH
28	12-3270	2	Screw

Ref	Part No.	Qty.	Description
29	3256-1	2	Washer-Flat
30	104-7014	1	Cover-Brake, Parking
32	3256-23	1	Washer-Flat
33	3296-39	1	Nut-Lock, NI
34	3290-477	1	Washer-Curved
35	104-6842	1	Lever-Brake, Park
35:1	106-7972	1	Grip-Handle
36	87-3480	1	Bracket-Equalizer, Cable
37	32120-47	2	Ring-Retaining, External
38	104-6844-03	1	Support-Brake, Park
39	323-10	1	Screw-HH
40	94-3829	1	Pin-Clevis
41	3272-6	1	Pin-Cotter

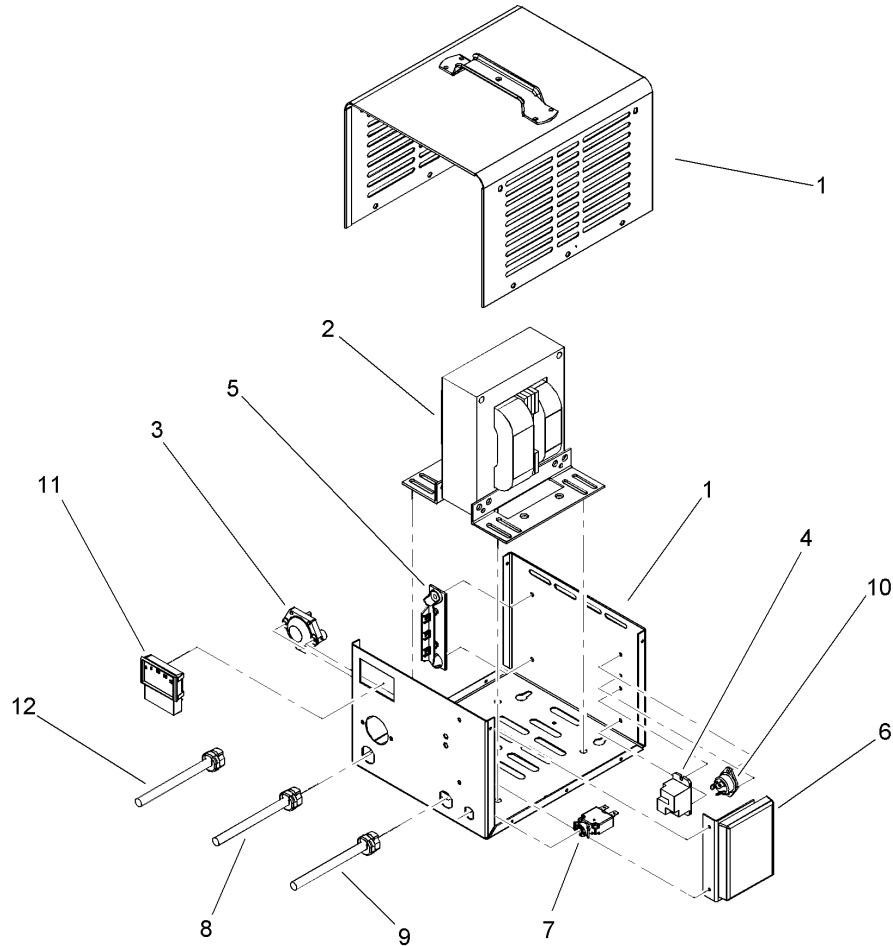

## Offboard 48 Volt Charger Assembly No. 112-3072

Ref	Part No.	Qty.	Description
❶		1	Case ASM
❷		1	Transformer ASM
3	108-1161	1	Fuse ASM
4	108-1162	1	Relay-48V, Dc
5	108-1163	1	Diode ASM
6	112-3073	1	Control Board ASM
7	110-2579	1	Breaker-Circuit
8	108-1166	1	Kit-Cordset, 8.5 Foot (Dc)
9	108-1167	1	Kit-Cordset, 72 Inch (Ac) Us
10	108-1168	1	Terminal And Screw ASM
11	108-1169	1	Ammeter
12	108-3071	1	Kit-Cordset, 20 Foot (Dc)

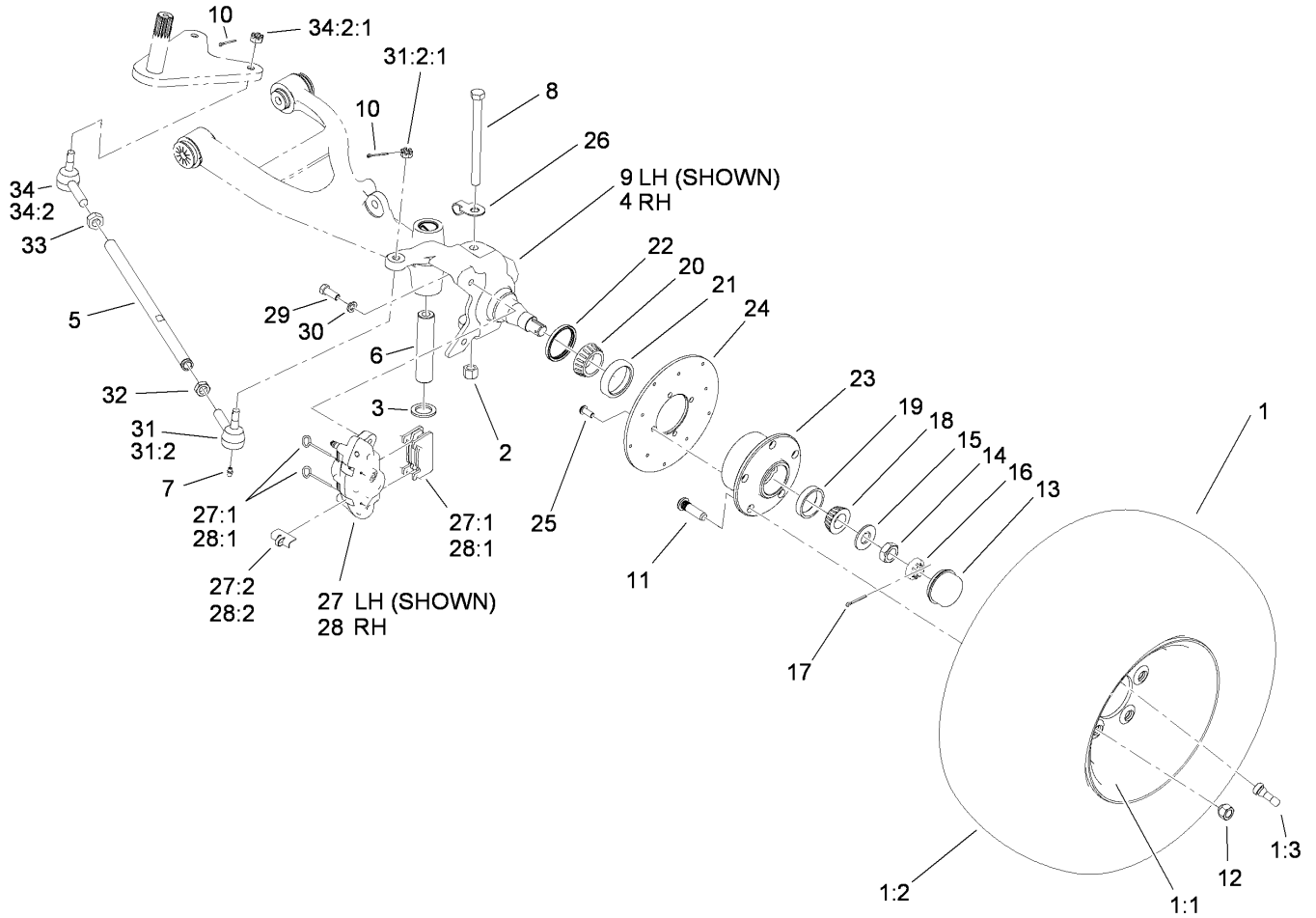

## Front Tire, Spindle and Tie Rod Assembly

Ref	Part No.	Qty.	Description
1	104-7290	2	Tire And Wheel ASM
1:1	104-7288	1	Wheel
1:2	104-7289	1	Tire
1:3	232-27	1	Stem-Valve
2	3296-23	2	Nut-Lock, NI
3	256-115	2	Washer-Thrust
4	112-3167	1	Spindle-RH
5	115-7654	2	Tie Rod
6	99-7499	2	Sleeve-Kingpin
7	302-5	4	Fitting-Grease
8	325-20	2	Screw-HH
9	112-3166	1	Spindle-LH
10	3272-7	4	Pin-Cotter
11	10-6830	10	Stud-Type, Drive
12	242-50	10	Nut-Lug
13	241-119	2	Cap-Dust
14	3220-7	2	Nut-Jam
15	93-0309	2	Washer-Tab
16	93-0307	2	Nut-Lock, Retainer
17	3272-12	2	Pin-Cotter
18	254-94	2	Bearing-Cone, Tapered
19	254-72	2	Bearing-Cup, Tapered
20	254-106	2	Cone-Bearing, Tapered
21	254-107	2	Cup-Bearing, Tapered

Ref	Part No.	Qty.	Description
22	108-7019	2	Seal-Shaft
23	104-6809	2	Hub
24	104-6891	2	Rotor
25	3274-55	8	Screw-HSBH
26	112-3311	2	Clip-Hose
27	112-3150	1	Caliper-LH
27:1	107-0708	1	Friction Pad And Pin Kit
27:2	112-3152	1	Spring-Rattle, Anti
28	112-3151	1	Caliper-RH
28:1	107-0708	1	Friction Pad And Pin Kit
28:2	112-3152	1	Spring-Rattle, Anti
29	323-6	4	Screw-HH
30	3253-21	4	Washer-Lock
31	112771-03	2	LH Ball Joint ASM
● 31:2		1	Joint-Ball, LH
31:2:1	915031	1	Nut
32	3218-21	2	Nut-Jam
33	3220-11	2	Nut-Jam
34	112772-03	2	RH Ball Joint ASM
● 34:2		1	Joint-Ball, RH
34:2:1	915031	1	Nut

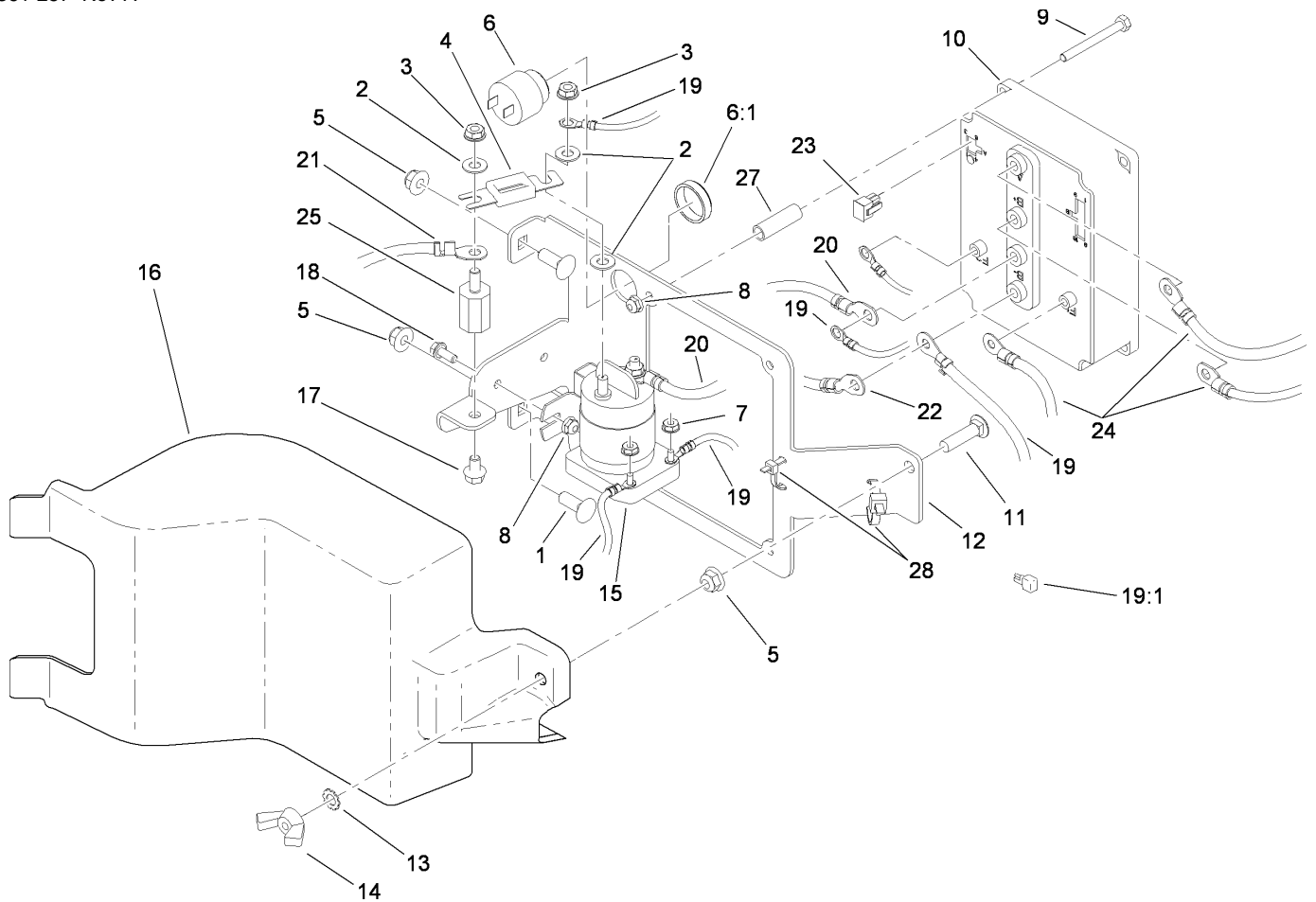

## Controller Assembly

Ref	Part No.	Qty.	Description
1	3231-22	2	Screw-CARR
2	107-0394	3	Washer-Flat
3	107-0380	3	Nut-HHF
4	104-7320	1	Fuse
5	104-8301	3	Nut-Flange, NI
6	94-5582	1	Alarm-Audio
6:1	104-5107	1	Nut-Plastic, Knurled
7	32149-8	2	Nut-Keps
8	104-7201	6	Nut-HF
9	321-15	4	Screw-HH
10	110-2569	1	Controller-Sevcon
11	3231-4	1	Screw-CARR
12	104-7137-03	1	Mount-Controler
13	3255-9	1	Washer-Lock
14	32103-3	1	Nut-Wing
15	104-7136	1	Contacto-48V
16	104-7138	1	Cover-Controller
17	100-1719	1	Screw-Flange
18	3234-33	2	Screw-HHF
19	115-7615	1	Harness-Wire, Main
19:1	100-4918	1	Diode
20	107-0740	1	Cable-Battery, Positive
21	107-0741	1	Cable-Battery, Positive
22	107-0742	1	Cable-Battery, Negative

Ref	Part No.	Qty.	Description
23	32160-130	1	Connector
24	107-0737	1	Harness-Wire, Battery Cable
25	107-0286	1	Isolator
27	107-0285	4	Spacer
28	3290-379	2	Tie-Cable

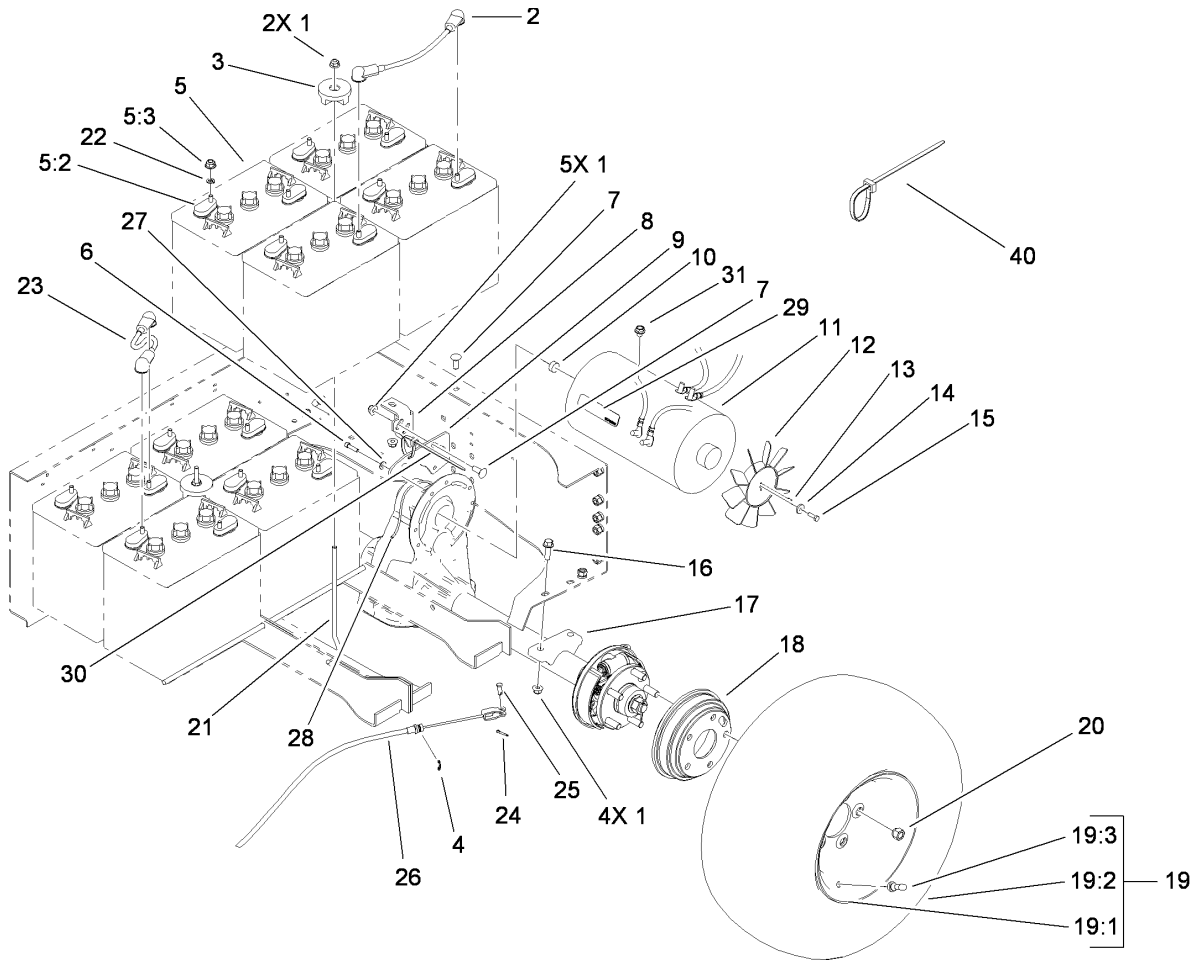

## Battery and Transaxle Assembly

Ref	Part No.	Qty.	Description
1	104-8301	11	Nut-Flange, NI
2	107-0739	1	Cable-Battery, Positive
3	104-7149	2	Hold Down ASM
4	32120-47	2	Ring-Retaining, External
5	8	1	Battery-Trojan T145
5:2	107-0289	2	Cover-Terminal, Battery
5:3	107-0388	2	Nut
6	3274-26	6	Screw-HSH
7	3231-22	5	Screw-CARR
8	104-7249-03	1	Bracket-Support
9	104-7305-03	1	Plate-Mount, Transaxle
10	112-3399	1	Damper-Rubber
11	104-7335	1	Motor-Electric
12	107-0259	1	Fan-10 Blade, Clockwise
13	32121-68	2	Pin-Roll
14	73-3580	1	Washer
15	3274-8	1	Screw-HSH
16	3234-24	4	Screw-HHF
17	114-8330	1	Transaxle-Electric
18	104-6500	2	Drum-Brake
19	104-7290	2	Tire And Wheel ASM
19:1	104-7288	1	Wheel
19:2	104-7289	1	Tire
19:3	232-27	1	Stem-Valve

Ref	Part No.	Qty.	Description
20	242-50	10	Nut-Lug
21	104-7339	2	Rod-Battery
22	107-0280	16	Washer-Lock
23	107-0738	6	Cable-Battery, Positive
24	3272-10	2	Pin-Cotter
25	283-62	2	Pin-Clevis
26	110-2647	2	Cable-Brake, Park
27	3256-22	6	Washer-Flat
28	110-1872	1	Hose-Fuel
29	107-0356	1	Decal-Motor
30	3290-379	12	Tie-Cable
31	107-0376	1	Screw-HSFH
40	3290-378	2	Tie-Cable



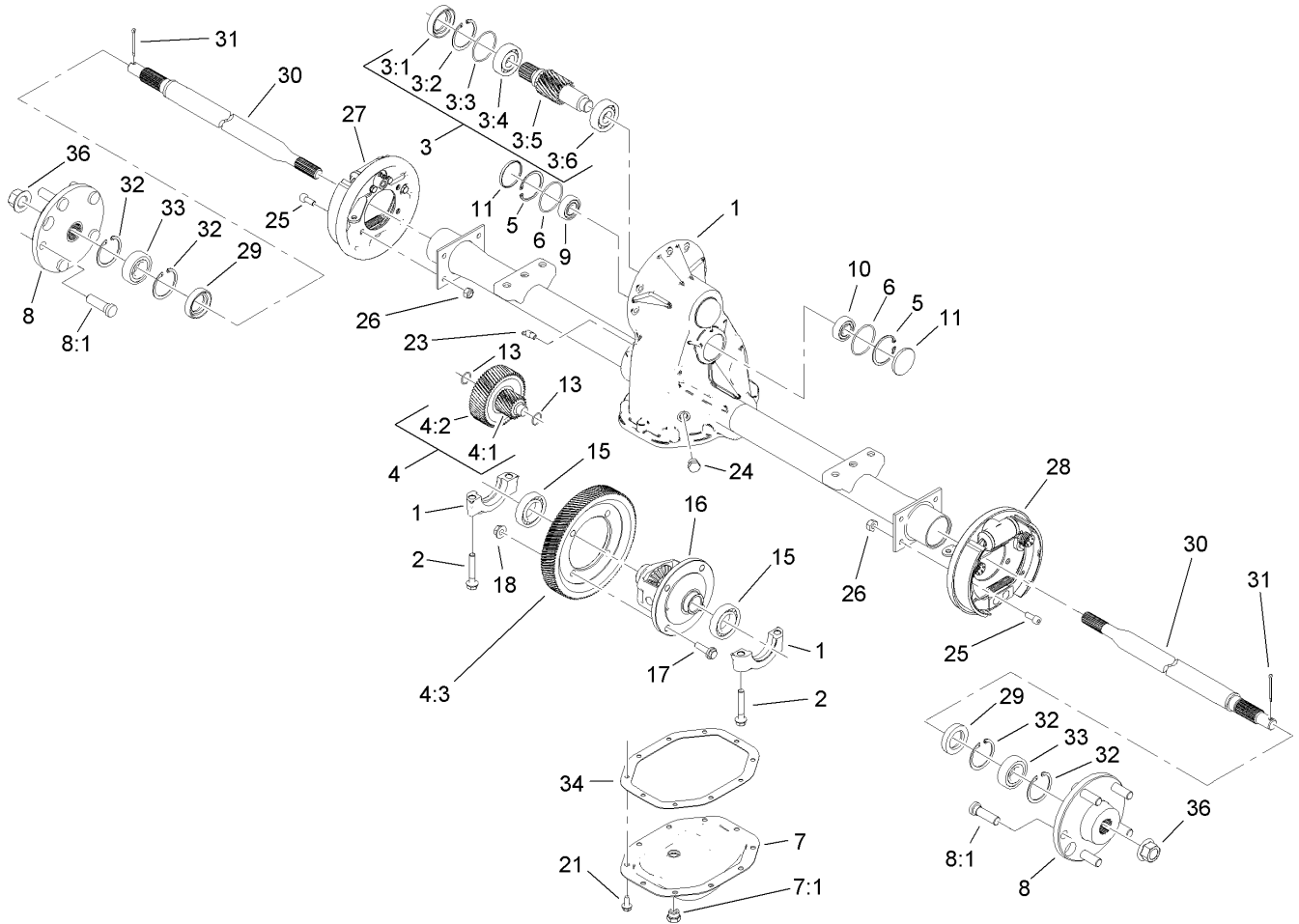

## Electric Transaxle Assembly No. 114-8330

Ref	Part No.	Qty.	Description
1		1	Transaxle ASM
2	108-2401	4	Bolt-Cap, Bearing
3	115-2185	1	Input Shaft Kit
3:1	108-2403	1	Seal-Oil
3:2	108-2404	1	Ring-Retaining
3:3	108-2405	1	O-Ring
3:4		1	Bearing-Ball
3:5		1	Shaft-Input
3:6		1	Bearing-Ball
4	108-2409	1	Internal Gear Kit
4:1		1	Shaft-Input
4:2		1	Gear-Intermediate
4:3	110-2541	1	Gear-Drive, Final
5	108-2404	2	Ring-Retaining
6	108-2405	2	O-Ring
7	108-2416	1	Cover Kit
7:1	108-2415	1	Plug-HH
8	112-3136	2	Hub ASM
8:1	112-3137	1	Bolt-Wheel
9	108-2406	1	Bearing-Ball
10	108-2407	1	Bearing-Ball
11	108-2408	2	Plug-Cap, End
13	108-2410	2	O-Ring
15	108-2411	2	Bearing-Ball

Ref	Part No.	Qty.	Description
16	112-3138	1	Differential ASM
17	108-2413	4	Screw-Hex
18	108-2414	4	Nut-Lock
21	108-2427	10	Screw-Tapping
23	108-2428	1	Elbow-90 Degree
24	108-2429	1	Plug-HH
25	112-3139	8	Screw-HSH
26	108-2418	8	Nut-Lock
27	114-8332	1	LH Brake ASM
28	114-8331	1	RH Brake ASM
29	112-3140	2	Seal-Oil
30	112-3141	2	Shaft-Axle
31	3272-12	2	Pin-Cotter
32	108-2424	4	Ring-Retaining
33	108-2425	2	Bearing-Ball
34	108-3148	1	Gasket
36	112-3142	2	Nut-HF









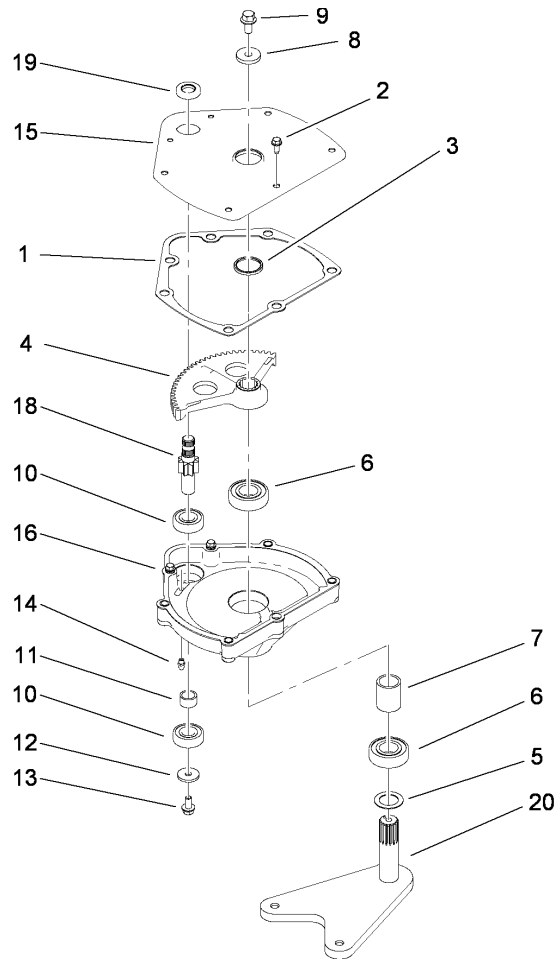

## Steering Box Assembly No. 112-3130

Ref	Part No.	Qty.	Description				
1	94-2135	1	Gasket				
2	32144-10	3	Screw-HWH				
3	103118	1	Seal				
4	99-7843	1	Sector-Gear				
5	3256-42	1	Washer-Flat				
6	251-82	2	Bearing-Ball				
7	112-2917	1	Spacer				
8	104-6563	1	Washer-Stepped				
9	104-7156	1	Screw-HHF				
10	38-7820	2	Bearing-Ball				
11	94-2217	1	Spacer-Shaft, Input				
12	1-613235	1	Washer				
13	98-3498	1	Screw-HH				
14	302-5	1	Fitting-Grease				
15	112-2918-03	1	Cover-Housing, Steering				
16	114-8309	1	Housing-Steering				
18	115-7726	1	Gear-Pinion				
19	99-7657	1	Seal-Oil				
20	112-3096-03	1	Pitman Arm ASM				

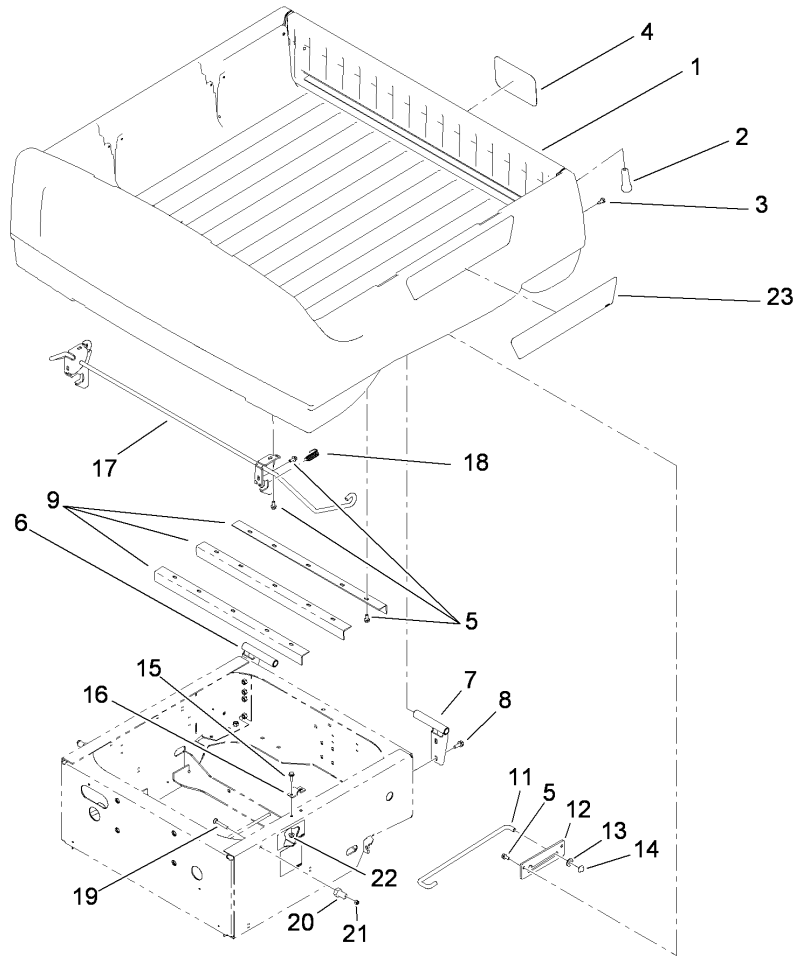

## Box and Tailgate Installation Assembly

Ref	Part No.	Qty.	Description
1		1	Box And Tailgate ASM
2	99-7984	2	Knob-Soft Grip, Push-On
3	87-8460	2	Bumper-Rubber
4	104-7213	1	Decal
5	3234-5	21	Screw-HHF
6	99-7309-03	1	RH Pivot Bracket ASM
7	99-7308-03	1	LH Pivot Bracket ASM
8	3234-11	4	Screw-HHF
9	99-7864-03	3	Brace-Box
11	99-7895	1	Rod-Prop
12	99-7894	1	Bracket-Rod, Prop
13	3256-26	1	Washer-Flat
14	32112-14	1	Nut-Push
15	3234-17	2	Screw-HHF
16	99-7896	1	Bracket-U, Prop Rod
17	115-2385	1	Rod-Latch
18	5-7290	2	Spring-Tension
19	3230-7	2	Screw-CARR
20	104-7248	2	Pin-Latch
21	3296-29	2	Nut-Lock, NI
22	104-8300	2	Nut-Flange, NI
23	115-2415	2	Decal

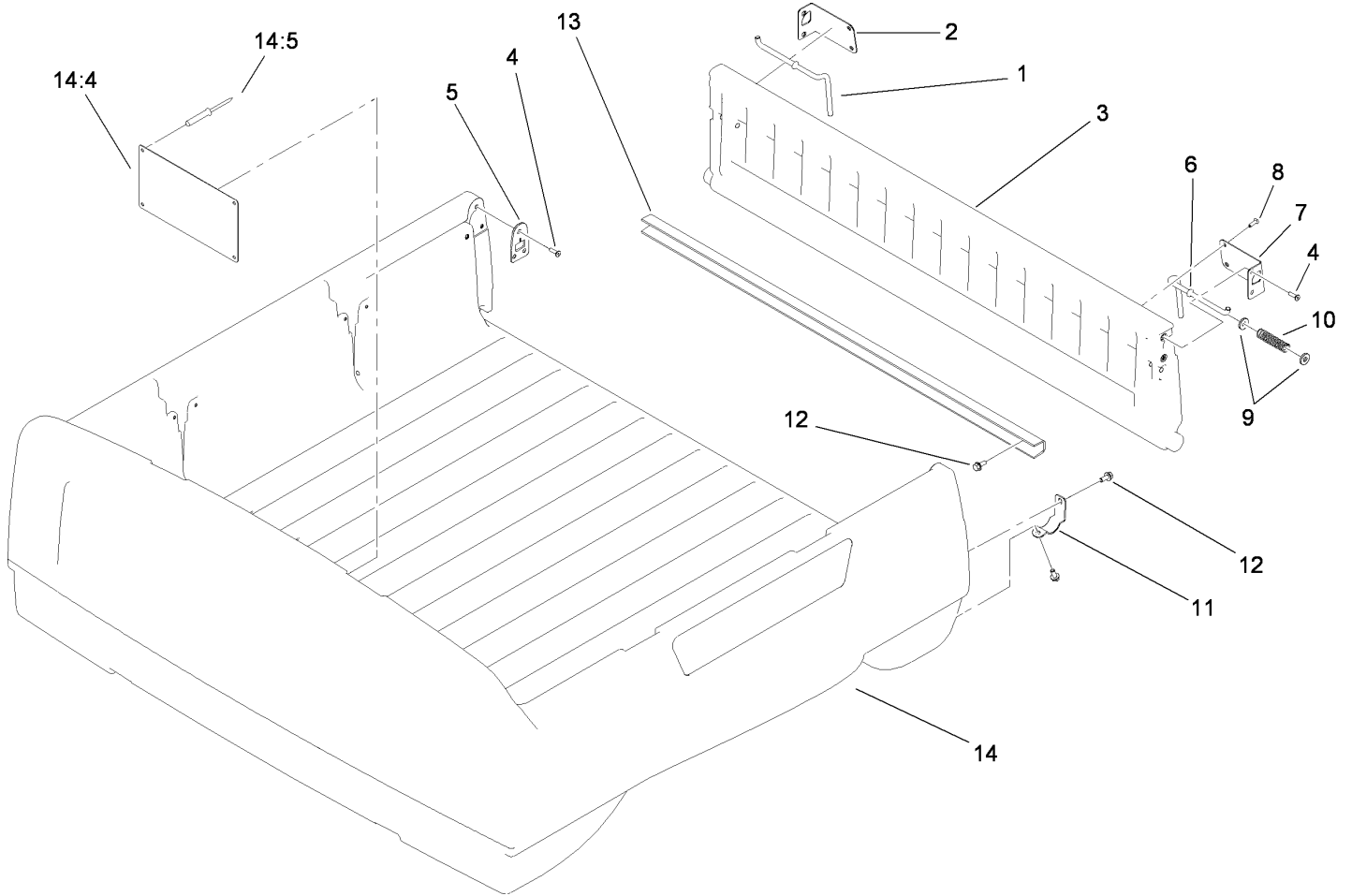

### Box and Tailgate Assembly

Ref	Part No.	Qty.	Description
1	99-7860	1	Rod-Latch, Right
2	99-7858	1	Bracket-Tailgate Latch, Right
3	115-7640	1	Tailgate ASM
4	99-7334	10	Screw
5	115-7676	2	Striker Plate ASM
6	99-7859	1	Rod-Latch, Left
7	99-7857	1	Bracket-Tailgate Latch, Left
8	99-7335	4	Screw
9	99-7861	4	Washer-Latch
10	61-8880	2	Spring
11	99-7286	2	Bracket-Pivot, Tailgate
12	3234-5	10	Screw-HHF
13	99-7867	1	Channel-Tailgate
14	115-7638	1	Box ASM
14:4	99-7954	1	Decal-No Riders
14:5	3290-415	4	Rivet

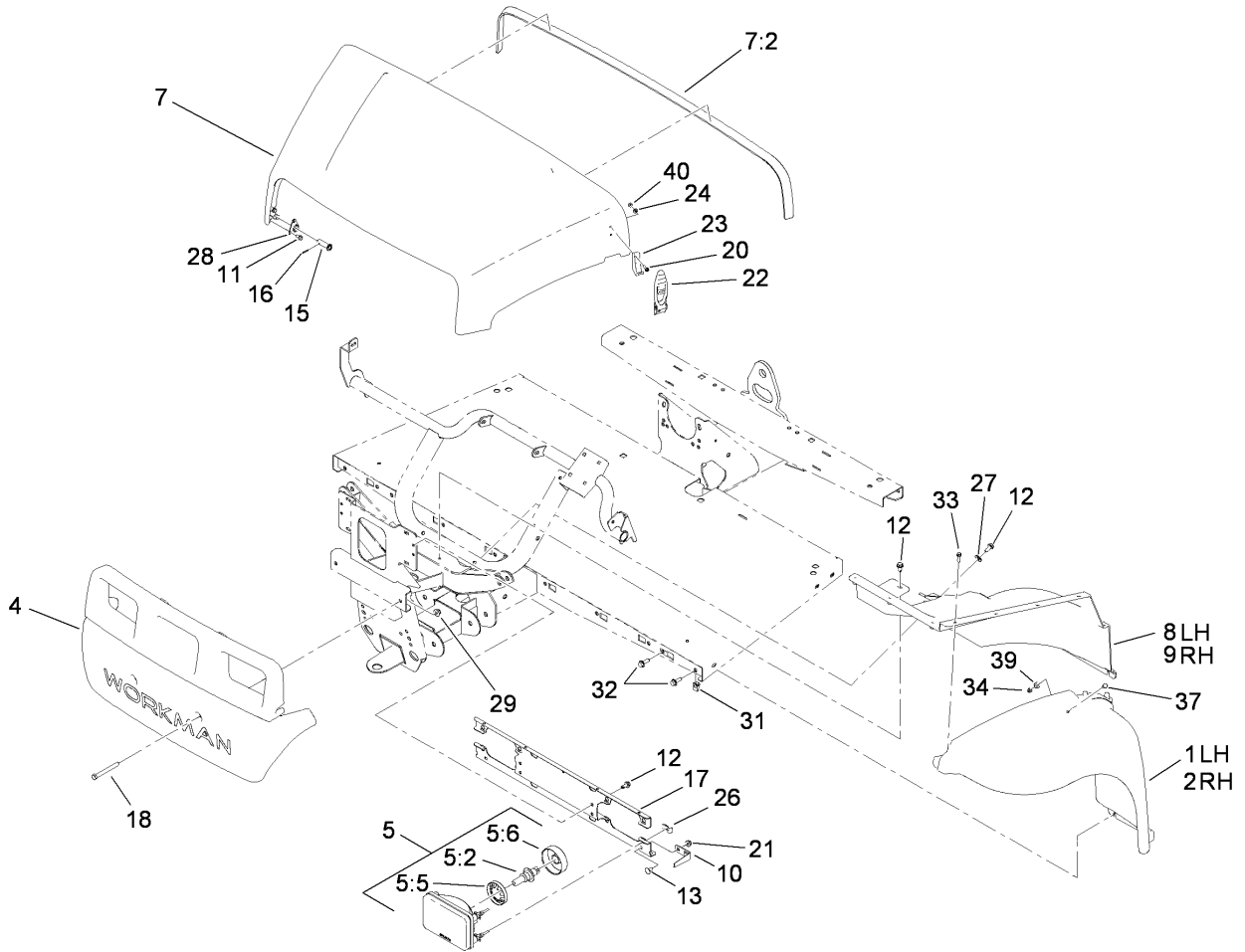

## Hood and Fender Assembly

Ref	Part No.	Qty.	Description
1	112-3371	1	Fender-LH
2	112-3370	1	Fender-RH
4	112-3365	1	Bumper
5	115-7617	2	Headlight ASM
5:2	115-7618	1	Bulb-24V
5:5	115-7667	1	Retainer-Headlight
5:6	115-7668	1	Boot-Headlight
7	115-7636	1	Hood ASM
7:2	115-7635	1	Seal-Foam
8	112-3369	1	Well-Fender, LH
9	112-3368	1	Well-Fender, RH
10	112-3373	2	Keeper-Pivot, Hood
11	46-8093	6	Screw-Plastite
12	32104-32	8	Screw-HWH
13	3230-18	2	Screw-CARR
15	112-2916	2	Pin-Pivot, Hood
16	32121-50	2	Pin-Spring
17	112-2915-03	1	Bracket-Light, Head
18	115-7660	2	Screw-HHF
20	32105-13	4	Screw-HWH
21	104-8300	2	Nut-Flange, NI
22	115-2416	2	Latch-Rubber
23	103-2897	2	Latch-Catch
24	3256-14	4	Washer-Flat

Ref	Part No.	Qty.	Description
26	115-2408	6	Clip-Speed
27	3256-71	2	Washer-Flat
28	112-3308	2	Retainer-Pin
29	104-8301	2	Nut-Flange, NI
31	112-3306	10	Nut
32	3234-29	10	Screw-HHF
33	46-8091	20	Screw-HWH
34	3296-42	2	Nut-Lock, NI
37	321-39	2	Screw-HH
39	3256-22	2	Washer-Flat
40	3296-2	4	Nut-Lock

# Attachments and Accessories

For 07299 - Workman MDE Utility Vehicle

Product Name	Model/Part
Electric Bed Lift Kit .....	07260
Rear Lift Kit .....	07261
Roll-Over Protection System .....	07276
Receiver Hitch Kit .....	07278
12V Converter Kit .....	07286
Stake Side Kit .....	07290

