



Bio-Diesel Fuel Filter Kit

Daihatsu-Powered Riding Mowers

Model No. 115-3550

Installation Instructions

After this kit is installed, this machine can use a biodiesel blended fuel of up to B20 (20% biodiesel, 80% petrodiesel). The petrodiesel portion should be low or ultra low sulfur.



Fuel is harmful or fatal if swallowed. Long-term exposure to vapors can cause serious injury and illness.

- Avoid prolonged breathing of vapors.
- Keep face away from nozzle and gas tank or conditioner opening.
- Keep fuel away from eyes and skin.



In certain conditions, fuel is extremely flammable and highly explosive. A fire or explosion from fuel can burn you and others and can damage property.

- Wipe up any fuel that spills.
- Never fill the fuel tank inside an enclosed trailer.
- Never smoke when handling fuel, and stay away from an open flame or where fuel fumes may be ignited by a spark.

Loose Parts

Use the chart below to verify that all parts have been shipped.

Procedure	Description	Qty.	Use
1	No parts required	–	Remove the existing water separator
2	Mounting plate Locknut (1/4 inch) Fuel filter clamp Bolt (5/16 x 1-3/4 inches) Bolt (5/16 x 3/4 inch) Locknut (5/16 inch) Water separator	1 1 1 1 1 2 1	Install the water separator.
3	Hose Hose clamp J-clamp Plastic tie	1 3 1 2	Installing and connecting the fuel hoses.
4	Low sulfur decal Fuel cap Diesel decal	2 2 1	Install the decals and fuel caps.
5	No parts required	–	Verify the connections.

1

Removing the Existing Water Separator

No Parts Required

Procedure

Important: Allow the engine to cool before installing this kit.

1. Drive the machine to a well ventilated area away from an open flame or where fuel fumes may be ignited by a spark.
2. Disengage the power take off (PTO) and set the parking brake.
3. Turn off the engine, remove the key, and wait for all moving parts to stop before leaving the operating position.
4. Disconnect the negative battery cable from the battery.
5. Allow the engine to cool before installing this kit.
6. Tilt the seat forward and remove the front engine panel (Figure 1).
7. Close the fuel selector valve.

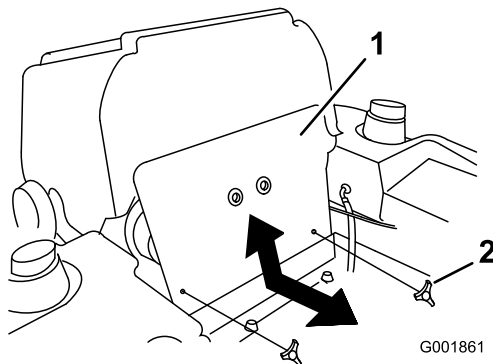

Figure 1

1. Knob
2. Front engine panel

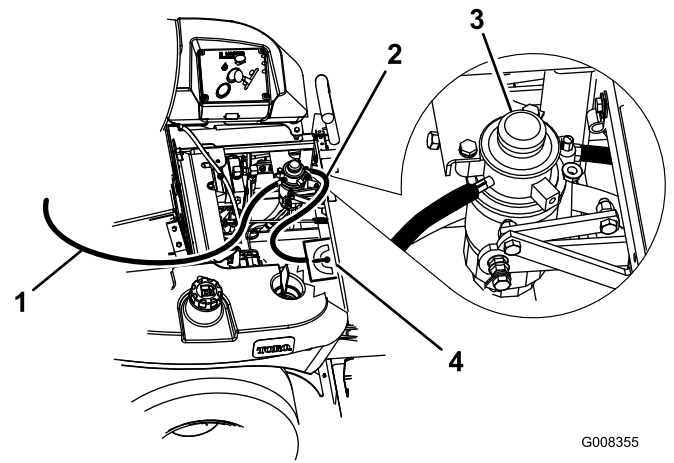

Figure 2

1. Fuel hose from the separator to the engine (make note where the connection is on the engine)
2. Hose from fuel selector valve
3. Existing water separator
4. Fuel selector valve

2

Installing the Water Separator

Parts needed for this procedure:

1	Mounting plate
1	Locknut (1/4 inch)
1	Fuel filter clamp
1	Bolt (5/16 x 1-3/4 inches)
1	Bolt (5/16 x 3/4 inch)
2	Locknut (5/16 inch)
1	Water separator

Procedure

1. Remove the existing hardware from the engine strap (Figure 3).
2. Install the mounting bracket to the engine strap with the previously removed hardware (Figure 3).
3. Install the water separator into the fuel filter clamp and install it to the mounting bracket with a bolt (5/16 x 1-3/4 inches), a bolt (5/16 x 3/4 inch), and 2 locknuts (5/16 inch) (Figure 3).
8. Locate the hose between the water separator and the fuel selector valve. Remove the fuel hose from the fuel selector valve (Figure 2).
9. Locate the hose between the water separator and the fuel selector valve. Remove the fuel hose from the the engine (Figure 2). Remember the location where the fuel hose was connected to the engine.
10. Remove the existing water separator from the machine.

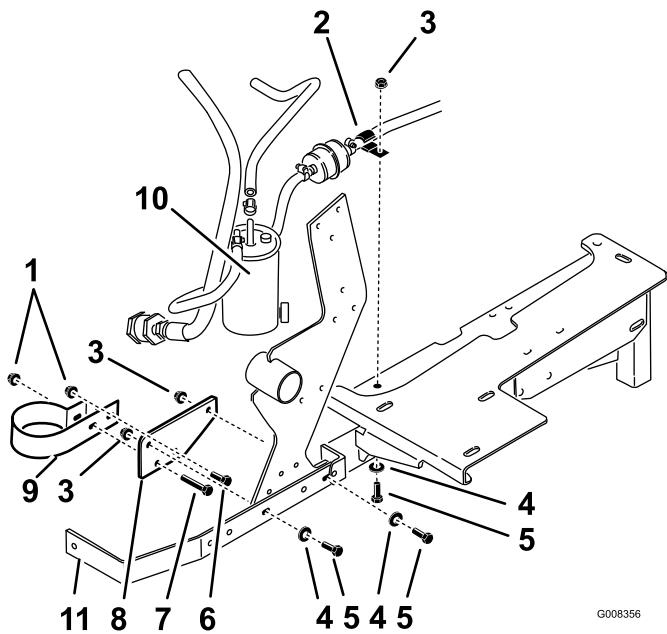

Figure 3

- | | |
|---------------------------|-------------------------------|
| 1. Locknut (5/16 inch) | 7. Bolt (5/16 x 1-3/4 inches) |
| 2. J-clamp | 8. Mounting plate |
| 3. Existing locknut | 9. Fuel filter bracket |
| 4. Existing washer | 10. Water separator |
| 5. Existing bolt | 11. Engine strap |
| 6. Bolt (5/16 x 3/4 inch) | |

5. Install the plastic ties to secure the hoses from touching any hot parts of the machine.

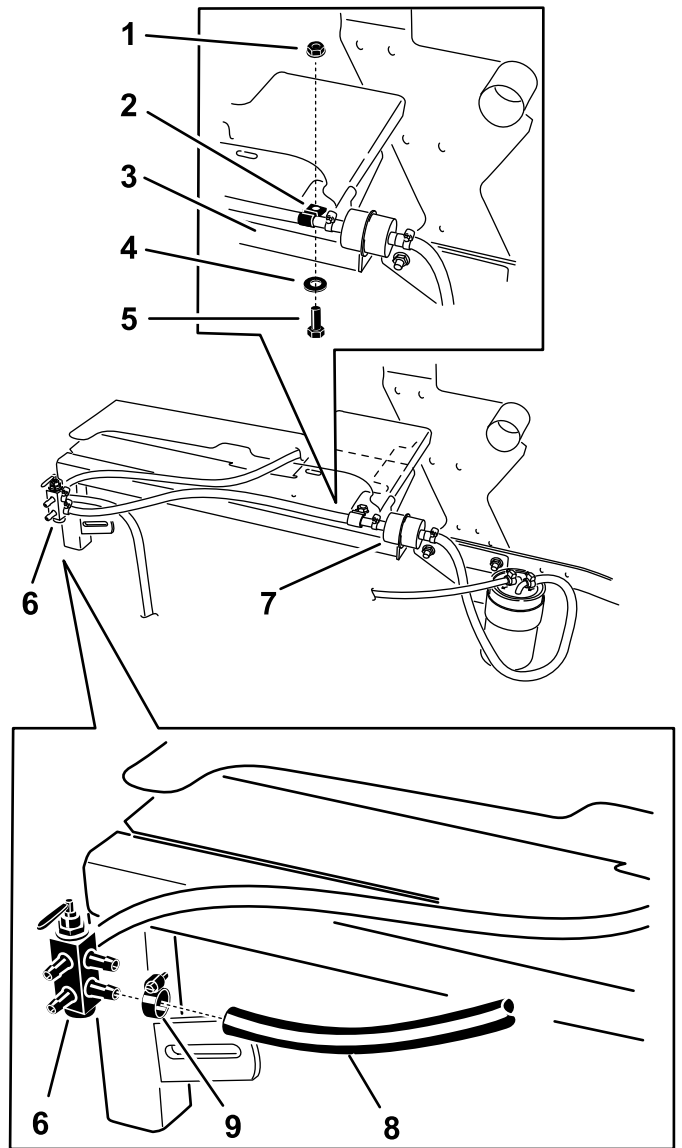

Figure 4

- | | |
|---------------------|------------------------|
| 1. Existing locknut | 6. Fuel selector valve |
| 2. J-clamp | 7. Fuel filter |
| 3. Engine frame | 8. Fuel hose |
| 4. Existing washer | 9. Hose clamp |
| 5. Existing bolt | |

3

Installing and Connecting the Fuel Hoses

Parts needed for this procedure:

1	Hose
3	Hose clamp
1	J-clamp
2	Plastic tie

Procedure

1. Route the fuel filter and fuel hose towards the fuel selector valve. Make sure no parts or hoses are touching the machine in areas that will get hot.
2. Remove the existing hardware and install the J-clamp to the engine frame (Figure 3 and Figure 4).
3. Install the fuel hose connected to the fuel filter into the J-clamp (Figure 4).
4. Install the new fuel hose onto fuel selector valve with a hose clamp (Figure 4).

- Install the new fuel hose to the water separator and to the engine fuel connection with 2 hose clamps (Figure 5). The connection to the engine is the same position as the fuel hose that was previously removed.

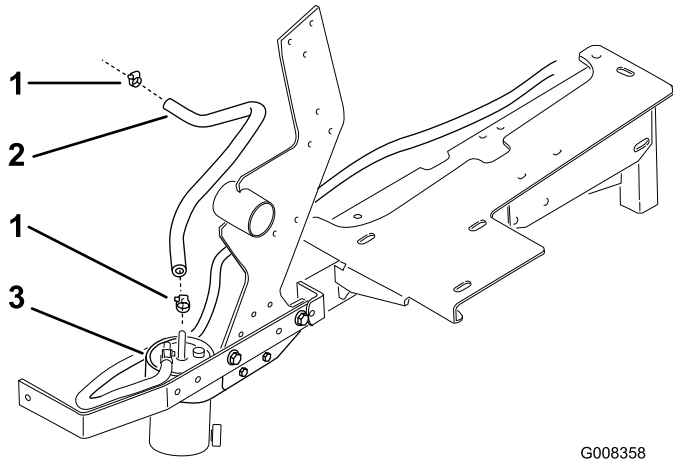

Figure 5

- Hose clamp
- New fuel hose, connect this end to the engine fuel intake
- Water separator

4

Installing the Decals and Fuel Caps

Parts needed for this procedure:

2	Low sulfur decal
2	Fuel cap
1	Diesel decal

Procedure

- Lower the engine hood.
- Remove the existing decal on each side.
- Install a low sulfur decal on each side of the engine hood. See Figure 6 for the correct position.

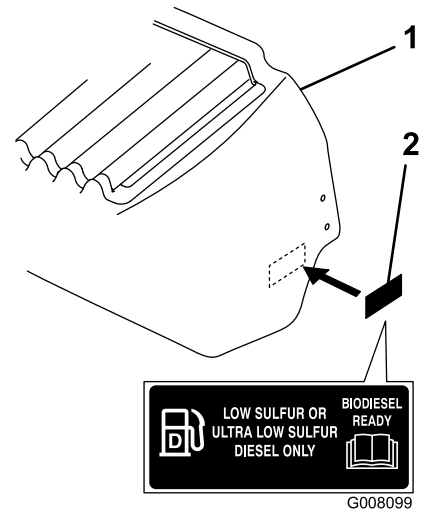

Figure 6

- Engine hood
- Low sulfur decal

- Clean the existing front decal and the area around it and let it dry (Figure 7).
- Install the new diesel decal over the existing one. See Figure 7.

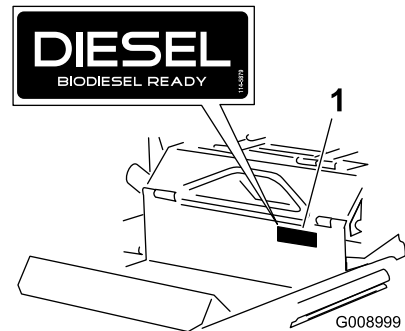

Figure 7

- Diesel decal

- Remove both existing fuel caps and replace them with the new fuel caps (Figure 8).

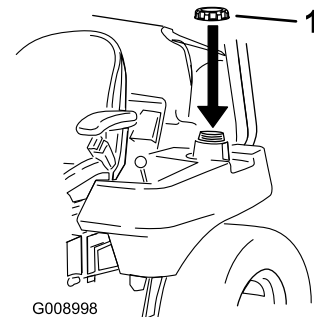

Figure 8

- New fuel cap

5

Verifying the Connections

No Parts Required

Procedure

1. Open the fuel selector valve.
2. Open the water separator drain valve until fuel starts to drain out and close the valve (Figure 9).
3. Ensure there are no leaks at the fuel hose connections.
4. Install the negative battery cable onto the battery.
5. Start the engine and ensure there are no leaks.

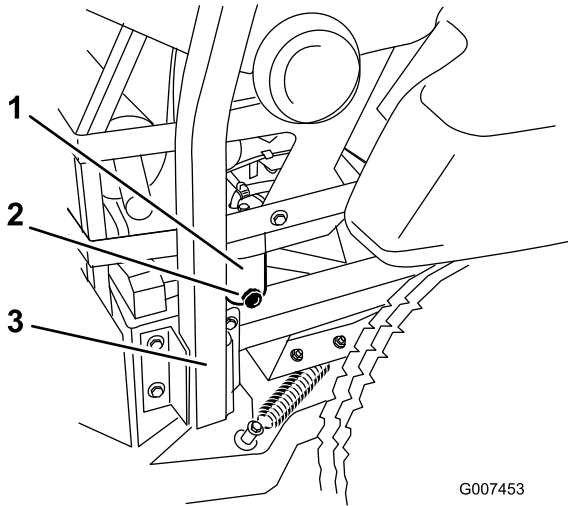

Figure 9

1. Water separator
2. Drain valve
3. Right side of machine

Operation

Adding Fuel

After this kit is installed, this machine can use a biodiesel blended fuel of up to B20 (20% biodiesel, 80% petrodiesel). The petrodiesel portion should be low or ultra low sulfur.

Observe the following precautions:

- The biodiesel portion of the fuel meet specification ASTM D6751 or EN14214.
- The blended fuel composition should meet ASTM D975 or EN590.
- Painted surfaces may be damaged by biodiesel blends.
- Use B5 (biodiesel content of 5%) or lesser blend in cold weather.
- Monitor seals, hoses, gaskets in contact with fuel as they may be degrade over time.
- Fuel filter plugging maybe expected for a time after converting to biodiesel blends.
- Contact your distributor if you wish for more information on biodiesel.

Purchase fuel in quantities that can be used within 30 days to ensure fuel freshness.

Use summer grade diesel fuel (No. 2-D) at temperatures above 20° F (-7° C) and winter grade diesel fuel (No. 1-D or No. 1-D/2-D blend) below 20° F (-7° C). Use of winter grade diesel fuel at lower temperatures provides lower flash point and pour point characteristics, therefore easing startability and lessening chances of chemical separation of the fuel due to lower temperatures (wax appearance, which may plug filters).

Use of summer grade diesel fuel above 20° F (-7° C) will contribute toward longer life of the pump components.

Important: Do not use kerosene or gasoline instead of diesel fuel. Failure to observe this caution will damage the engine.



In certain conditions, fuel is extremely flammable and highly explosive. A fire or explosion from fuel can burn you and others and can damage property.

- Fill the fuel tank outdoors, in an open area, when the engine is cold. Wipe up any fuel that spills.
- Never fill the fuel tank inside an enclosed trailer.
- Do not fill the fuel tank completely full. Add fuel to the fuel tank until the level is 1/4 to 1/2 inch (6 to 13 mm) below the bottom of the filler neck. This empty space in the tank allows fuel to expand.
- Never smoke when handling fuel, and stay away from an open flame or where fuel fumes may be ignited by a spark.
- Store fuel in an approved container and keep it out of the reach of children. Never buy more than a 30-day supply of fuel.
- Always place fuel containers on the ground away from your vehicle before filling.
- Do not fill fuel containers inside a vehicle or on a truck or trailer bed because interior carpets or plastic truck bed liners may insulate the container and slow the loss of any static charge.
- When practical, remove gas-powered equipment from the truck or trailer and refuel the equipment with its wheels on the ground.
- If this is not possible, then refuel such equipment on a truck or trailer from a portable container, rather than from a fuel dispenser nozzle.
- If a fuel dispenser nozzle must be used, keep the nozzle in contact with the rim of the fuel tank or container opening at all times until fueling is complete.



Fuel is harmful or fatal if swallowed. Long-term exposure to vapors can cause serious injury and illness.

- Avoid prolonged breathing of vapors.
- Keep face away from nozzle and gas tank or conditioner opening.
- Keep gas away from eyes and skin.

Filling the Fuel Tank

1. Shut the engine off and set the parking brake.
2. Clean around each fuel tank cap and remove the cap. Add fuel to both fuel tanks, until the level is 1/4 to 1/2 inch (6 to 13 mm) below the bottom of the filler neck. This space in the tank allows the fuel to expand. Do not fill the fuel tanks completely full.
3. Install fuel tank caps securely. Wipe up any fuel that may have spilled.
4. If possible, fill the fuel tank after each use. This will minimize possible buildup of condensation inside the fuel tank.

Maintenance

Servicing the Fuel Filter

Draining the Water Separator

Service Interval: Every 40 hours

1. Position the machine on a level surface.
2. Disengage the PTO, move the motion control levers to the neutral locked position and set the parking brake.
3. Stop the engine, remove the key, and wait for all moving parts to stop before leaving the operating position.
4. Locate the water separator at the back left of the machine.
5. Place a drain pan below the water separator.
6. Open the drain valve on the water separator approximately one turn to allow water and other contaminants to drain (Figure 10).
7. Close the drain valve when only diesel fuel comes out (Figure 10).

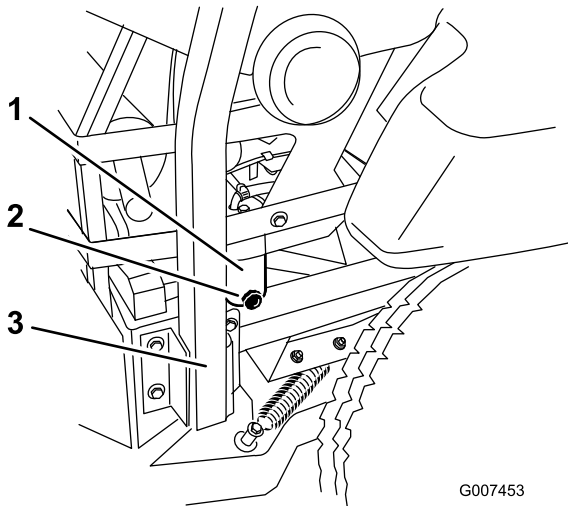

Figure 10

G007453

1. Water separator
2. Drain valve
3. Right side of machine

Changing the Fuel Filter

Service Interval: Every 400 hours/Yearly (whichever comes first) (more often in dirty or dusty conditions).

Never install a dirty fuel filter if it is removed from the fuel line.

1. Allow the machine to cool down.
2. Disengage the PTO, move the motion control levers to the neutral locked position and set the parking brake.
3. Stop the engine, remove the key, and wait for all moving parts to stop before leaving the operating position.
4. Close the fuel shut-off valve.
5. Loosen the two hose clamps and disconnect the fuel lines from the fuel filter (Figure 11).
6. Install a new filter. Connect the fuel lines to the fuel filter and install the two hose clamps.
7. Open the fuel shut-off valve.
8. Start the engine and check for leaks.

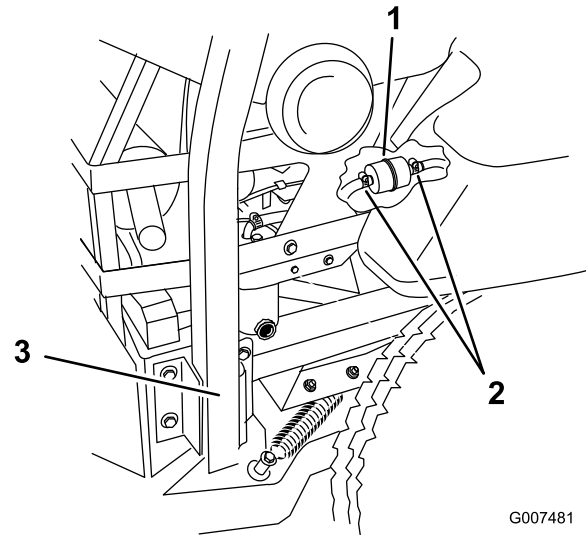

Figure 11

G007481

1. Fuel filter
2. Hose clamps
3. Right side of machine



Count on it.