



# Kubota-Powered Z Master® Mowers

## Setup Instructions

### Loose Parts

Use the chart below to verify that all parts have been shipped.

Procedure	Description	Qty.	Use
<b>1</b>	No parts required	–	Remove parts from the crate.
<b>2</b>	No parts required	–	Check the tire pressure.
<b>3</b>	Rear wheels	2	Install the drive wheels.
<b>4</b>	Roll bar, right section Roll bar, left section Roll bar, center section Bolt, (3/8 x 1 inch) Curved washer Flange nut, (3/8 inch) Bolt, (1/2 x 3–1/4 inch) Flange nut, (1/2 inch)	1 1 1 8 8 8 2 2	Install the Rollover Protection System (ROPS).
<b>5</b>	No parts required	–	Add fuel to the machine.
<b>6</b>	No parts required	–	Charge the battery.
<b>7</b>	Number 2 general purpose lithium base or molybdenum base grease. (Purchase separately.)	1 tube	Check the machine for grease.
<b>8</b>	No parts required	–	Check the engine oil level.
<b>9</b>	No parts required	–	Prepare the side discharge chute.
<b>10</b>	No parts required	–	Check the machine before delivery to the customer.
<b>11</b>	Operator's Manual Parts Catalog Engine Owner's Manual Registration Card Safety Video Key	1 1 1 1 1 2	Delivering the machine to the customer.

# 1

## Removing Parts from the Crate

No Parts Required

### Procedure

Remove the tires and the parts for the ROPS from the shipping crate.

# 2

## Checking the Tire Pressure

No Parts Required

### Procedure

Pressure: 13 psi (90 kPa)

**Note:** The front caster wheel is a semi-pneumatic tire and does not need to be checked.

Check the air pressure in the drive tires.

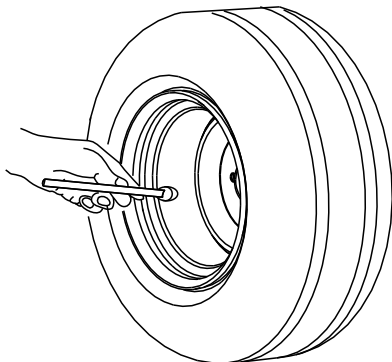

G001055

Figure 1

# 3

## Raising the Machine Up and Installing the Drive Wheels

Parts needed for this procedure:

2	Rear wheels
---	-------------

### Procedure

1. Remove the screws holding the right angle retaining plate to the crate.

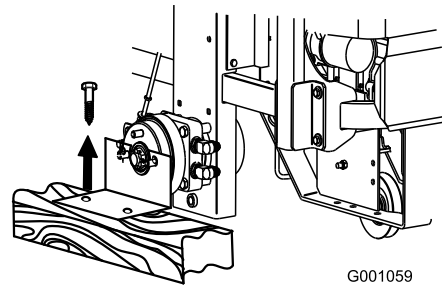

G001059

Figure 2

2. Raise the back of the machine up and support it with jack-stands.

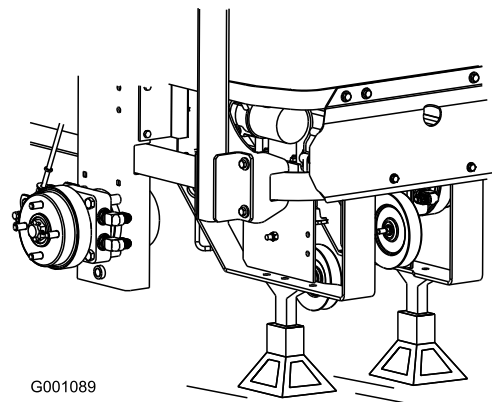

G001089

Figure 3

3. Remove the wheel nuts from both sides of the vehicle and remove the right angle retaining plate. Discard the screws and retaining plate.

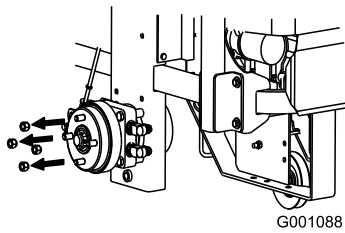

Figure 4

4. Mount the wheels with the valve stem to the outside and secure them with the wheel nuts previously removed.
5. Torque the wheel nuts to 95 ft-lb (128 N·m).
6. Remove the jack-stands.

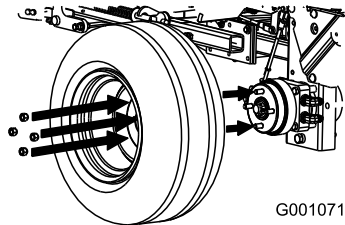

Figure 5

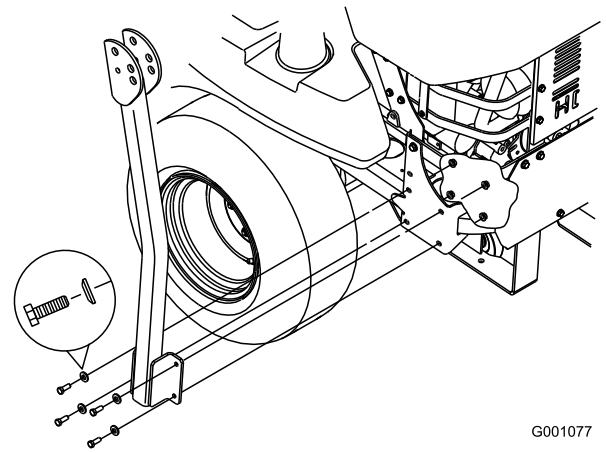

Figure 6

2. Install the lanyard clips onto the long bolts (1/2 x 3-1/4 inch).

**Note:** Make sure the bent tab points toward the head of the bolt.

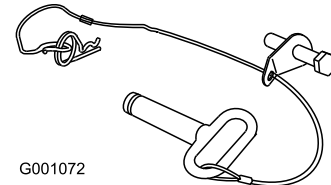

Figure 7

3. Lightly oil the ends of the center roll bar section.
4. Loosely install the center roll bar section using 2 bolts (1/2 x 3-1/4 inch) and 2 flange nuts (1/2 inch).

**Note:** Make sure the bolts are installed from the outside of the roll bar.

**Note:** Make sure the lanyard tab is installed as show and points forward.

# 4

## Installing the Roll Over Protection System

### Parts needed for this procedure:

1	Roll bar, right section
1	Roll bar, left section
1	Roll bar, center section
8	Bolt, (3/8 x 1 inch)
8	Curved washer
8	Flange nut, (3/8 inch)
2	Bolt, (1/2 x 3-1/4 inch)
2	Flange nut, (1/2 inch)

### Procedure

1. Loosely install the right and left roll bar section to the frame, with 8 bolts (3/8 x 1 inch), 8 curved washers, and 8 flange nuts (3/8 inch).

**Note:** The curve washer cone must be installed toward the bolt head.

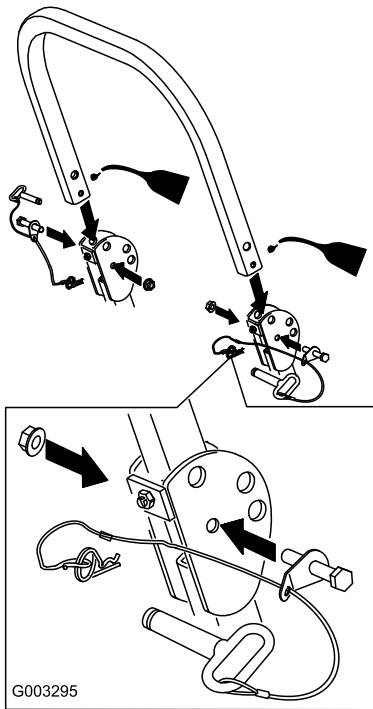

**Figure 8**

- 
5. Raise the roll bar into the upright position and secure it with the pins and hairpin cotter pins fastened to the lanyards

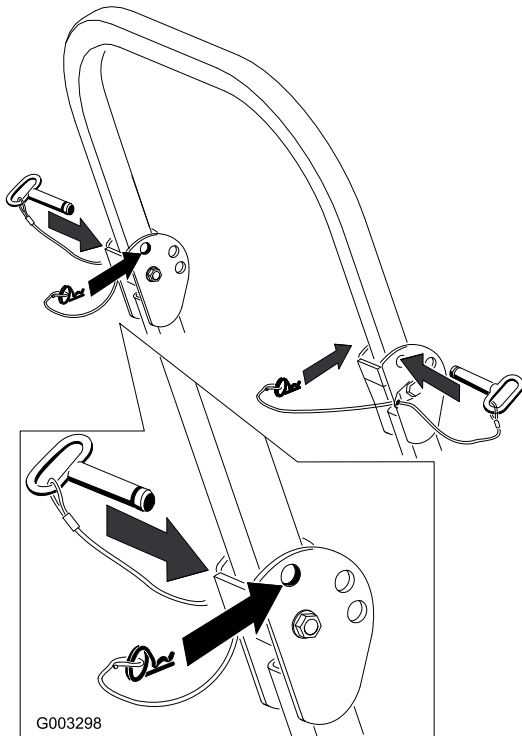

**Figure 9**

6. Torque all lower fasteners, attached to the machine frame, to 30 ft-lb.
7. Tighten the center roll bar bolts (1/2 x 3-1/4 inch) so it rotates freely with some resistance.

**Note:** No more than one thread should be exposed outside the nut.

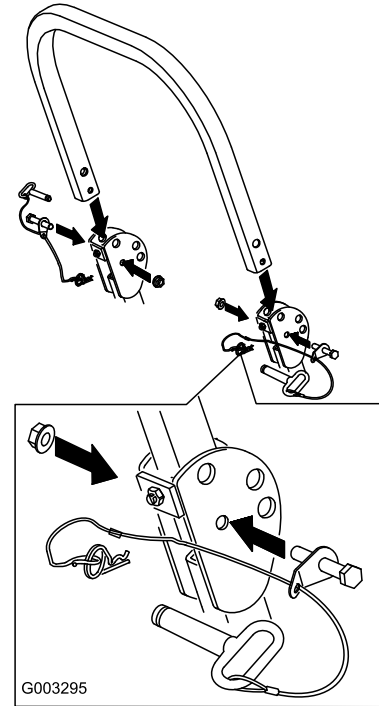

**Figure 10**

# 5

## Adding Fuel to the Machine

**No Parts Required**

### Procedure

Add fuel to the machine before starting it. Refer to your *Operator's Manual* for the correct fuel and procedure.

# 6

## Charging the Battery

No Parts Required

### Procedure



Charging the battery produces gasses that can explode and cause serious injury.

- Keep cigarettes, sparks and flames away from the battery.
- Make sure the ignition switch is off.
- Ventilate when charging or using the battery in an enclosed space.

**Important:** Do not run the machine with the battery disconnected; electrical damage may occur to the engine.

Charge the battery. Refer to the *Operator's Manual* for instructions.

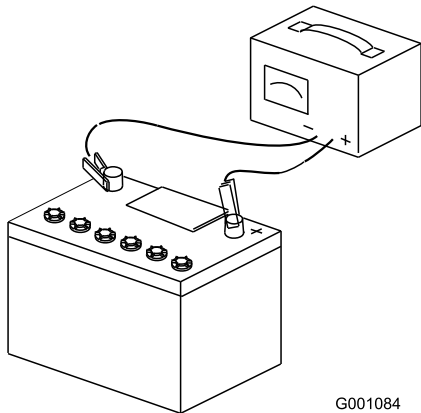

Figure 11

G001084

# 7

## Checking the Machine for Grease

Parts needed for this procedure:

1 tube	Number 2 general purpose lithium base or molybdenum base grease. (Purchase separately.)
--------	---

### Procedure

1. Remove the belt covers on domestic machines as shown below.

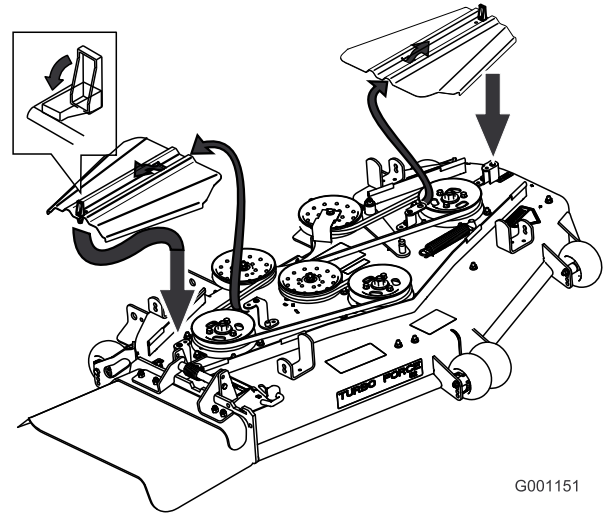

G001151

Figure 12

2. Remove the belt covers and bolts on international machines as shown below.

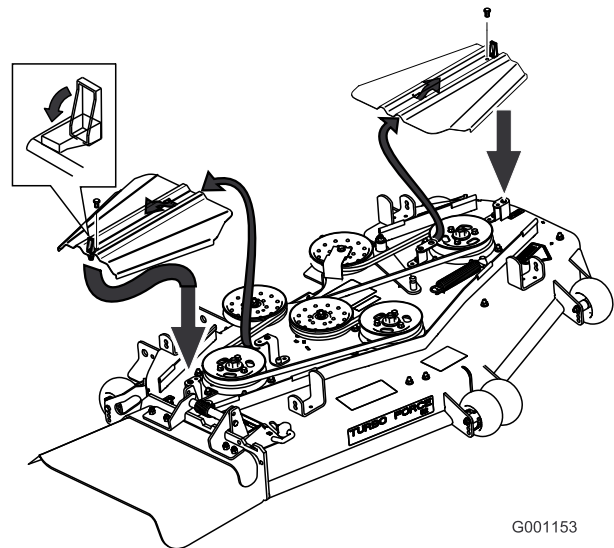

G001153

Figure 13

3. Check the tensioning arm for grease.
4. Check the grease for the three spindle bearings. If needed, add grease until it comes out of the lower seals.
5. Install the belt covers.

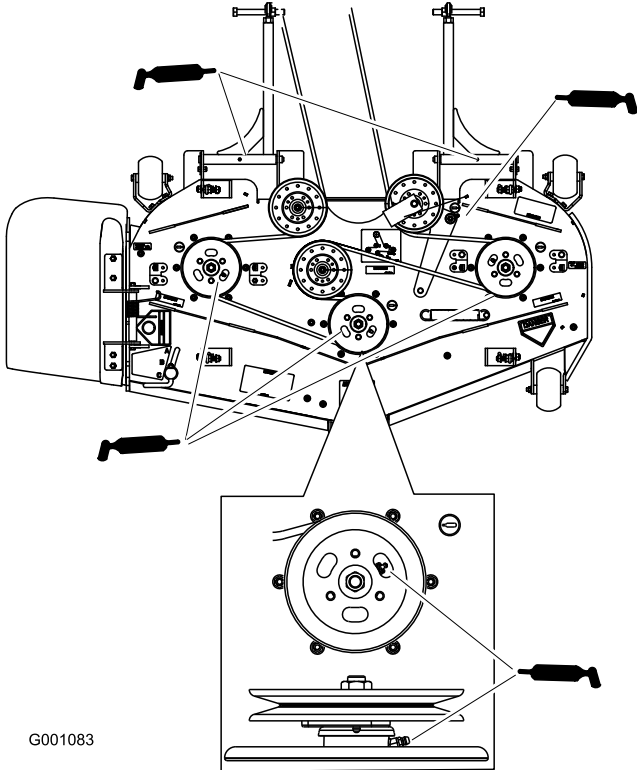

**Figure 14**

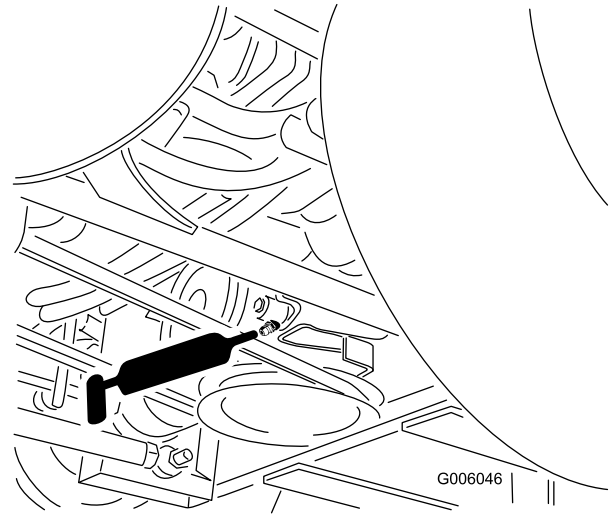

**Figure 16**

# 8

## Checking the Engine Oil Level

**No Parts Required**

### Procedure

Before you start the engine and use the machine, check the oil level in the engine crankcase; refer to Checking Oil Level in *Operator's Manual*.

6. Check the grease for the pump drive belt idler arm.

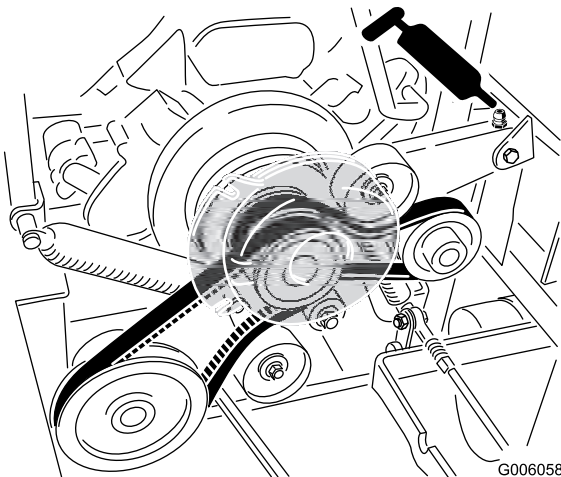

**Figure 15**

7. Check the grease for the PTO drive belt idler arm.

# 9

## Checking the Side Discharge Chute

### No Parts Required

### Procedure

If there are plastic ties holding the side discharge chute up, remove them and lower the chute into place.



An uncovered discharge opening could allow the lawn mower to throw objects in the operator's or bystander's direction and result in serious injury or death. Also, contact with the blade could occur.

Never operate the lawn mower with the grass deflector removed unless you install a cover plate, a mulch plate, or a grass chute and catcher.

1. Make sure the **L** end of spring is installed behind the deck edge before installing the bolt as shown in Figure 17.
2. Place the **J** hook end of spring around grass deflector (Figure 17).

**Important:** The grass deflector must be free to rotate with downward tension. Lift the deflector up to the full open position and ensure that it rotates freely, without binding into the full down position.

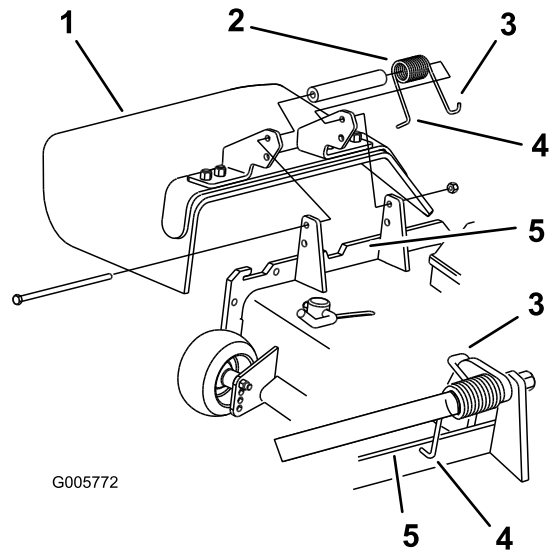

Figure 17

1. Grass Deflector
2. Spring
3. **J** hook end of spring
4. **L** end of spring, place behind deck edge before installing bolt
5. Deck edge

# 10

## Checking the Machine Before Delivery to the Customer

### No Parts Required

### Procedure

Before delivering the machine to the customer, ensure that you perform or have performed the procedures listed in the following table and initial each when finished. Refer to the Operator's Manual for instructions on performing these procedures.

Initial	Check Procedure
	Check the tire pressure.
	Check the level of the mower.
	Check that all mower spindles are greased.
	Check the engine oil level.
	Check the hydraulic fluid level.
	Check ROPS is secure.
	On liquid cooled machines, check the level of the coolant in the radiator and overflow bottle.
	Check the adjustment of the parking brake.
	Ensure that the machine tracks correctly; refer to the <i>Operator's Manual</i> for the adjustment procedure.
	Check the safety interlock system; refer to the <i>Operator's Manual</i> .
	Ensure that the PTO works.
	Check all fasteners you installed to ensure that they are tight.

When you finish setting up the machine, sign and date in the space provided below:

**Signature:** \_\_\_\_\_ **Date:** \_\_\_\_\_



# 11

## Delivering the Machine to the Customer

### Parts needed for this procedure:

1	<i>Operator's Manual</i>
1	<i>Parts Catalog</i>
1	<i>Engine Owner's Manual</i>
1	Registration Card
1	Safety Video
2	Key

### Procedure

At delivery, complete the items listed in the following table and initial each when finished.

Model No. \_\_\_\_\_ Serial No. \_\_\_\_\_

Dealer Initial	Customer Initial	Check Procedure
		Show the customer where the following features are located and how they function: Fuel tank caps Oil fill cap/ Oil dipstick Engine oil filter Engine oil drain Fuel filters Air filter Radiator coolant Hydraulic fluid reservoir Hydraulic filter Battery Ignition switch Throttle lever Glow plug light and switch Power take off switch (PTO) Motion control levers Parking brake Mower height-of-cut Lift assist lever Z Stand® (Only on International machines) Adjustable seat Hydraulic bypass valves Rollover Protection System (ROPS) Mower deck flow baffle
		Refer to the <i>Operator's Manual</i> to point out safety procedures, operation, and maintenance procedures.
		Review the warranty statement as shown in the <i>Operator's Manual</i> .
		Describe the post sale service procedures for your store.
		Assist the customer in filling out and mailing the registration card or register online at <a href="http://www.Toro.com">www.Toro.com</a>
		Make sure that the customer receives the <i>Operator's Manual, Parts Catalog, and Engine Owner's Manual, Set Up Instructions</i> , and safety video.
		Assist the customer in loading the mower.

**Note:** When you, the dealer representative, have finished delivering the machine to the customer, sign and date in the space provide below and keep a copy of this page for dealer records.

**Signature:** \_\_\_\_\_ **Date:** \_\_\_\_\_

**Signature:** \_\_\_\_\_ **Date:** \_\_\_\_\_

**Notes:**



**Count on it.**