

P Series Hydrostatic Pumps Service and Repair Manual

BLN-52503
January, 2014

Table of Contents

Section	Page
Description and Operation	1
Introduction	1
General Description	1
External Features.....	2-7
PC Series	2
PG/PE Series	3
PJ Series	4
PK Series.....	5
PR Series	6
PW/PY Series.....	7
Hydraulic Schematic	8-9
PC, PG, PE, PJ, PK and PR Series	8
PW and PY Series.....	9
Graphical Schematic	10
Technical Specifications.....	11
Product Identification	12
Safety	13
Personal Safety.....	13
Tool Safety	13
Work Area Safety	13
Servicing Safety	13
Troubleshooting	14-15
P Series Flow Test Kit Instructions.....	16-17
Service and Maintenance	18-20
External Maintenance	18
Service and Maintenance Procedures.....	18
Fluids	18
Fluid Volume and Level.....	19
Fluid Change.....	19
Filters	19
Purging Procedures	19
Return to Neutral Setting	20
Repair	21-126
PC Series Pump	21-36
PG/PE Series Pump	37-54
PJ Series Pump	55-72
PK Series Pump.....	73-90
PR Series Pump	91-108
PW/PY Series Pump.....	109-126
Glossary of Terms	127-128

FOREWORD

Headquartered in Sullivan, Illinois, Hydro-Gear is a world leader in the design, manufacture, and service of quality hydrostatic transaxles for the lawn and garden industry. The mission of our company is to be recognized by our customers and the industry as a world-class supplier and the quality leader in everything we do.

This Service and Repair Manual is designed to provide information useful in servicing the Hydro-Gear 6cc (0.37 cu in.) PC Series, the 10 cc (0.61 cu in.) PG Series, the 12 cc (0.73 cu in.) PJ Series, the 16 cc (0.98 cu in.) PR Series, and the 21 cc (1.28 cu in.) PW Series pumps.

Also included is a glossary of terms that are frequently used throughout the industry and in Hydro-Gear service publications. Understanding terminology is very important!

It is necessary, and good shop practice, that your service area be equipped with proper tools and the mechanics to be supplied with the latest information available. All repair procedures illustrated in this guide are suggested, but preferred methods of repair.

Some repair procedures require that the pump be removed from the vehicle.

This is not a certification, test or study guide for a certification test. If a technician is interested in certification they should contact an agent representing the OPEESA (Outdoor Power Equipment and Engine Service Association) (860-767-1770) or their Hydro-Gear Distributor. Many distributors will be hosting certification testing. These study guides will cover most of the products and manufacturers in our industry.

For more information about Hydro-Gear or our products, please contact your Central Service Distributor, or call our Customer Service Department at (217) 728-2581.

SECTION 1. DESCRIPTION AND OPERATION

INTRODUCTION

The purpose of this manual is to provide information useful in servicing the Hydro-Gear PC, PG, PE PJ, PK, PR, PW and PY Pumps. This manual includes the pump's general descriptions, hydraulic schematics, technical specifications, servicing and troubleshooting procedures for the pumps.

The P Series Pumps normally will not require servicing during the life of the vehicle in which it is installed. Should other servicing be required, the exterior of the pump will need to be thoroughly cleaned before beginning most procedures.

GENERAL DESCRIPTION

The P Series Pumps can be combined with wheel motors and other remotely located units. These pumps provide an infinitely variable speed range between zero and full displacement in both forward and reverse modes of operation.

The P Series Pumps are of the axial piston design, utilizing spherical nosed pistons. A compression spring, located inside each piston, holds the nose of the piston against a thrust bearing race.

The variable displacement pump features a cradle swashplate with a direct-proportional displacement control. Movement of the directional control shaft produces a proportional swashplate movement and a change in pump flow and/or direction.

Reversing the direction of the angle of the swashplate reverses the flow of oil from the pump and thus reverses the direction of motor output rotation.

A fixed displacement gerotor charge pump is provided in P Series Pumps. Oil from an external reservoir and filter is pumped into the closed loop by a charge pump. Fluid not required to replenish the closed loop flows either into the pump housing through a cooling orifice, or back to the charge pump inlet through the charge pressure relief valve.

Check or shock valves are included in the pump end cap to control the makeup oil flow for the system. The size and type of check valve can play an important role on the system pressure, response, and amount of heat generated, due to the recirculation of makeup oil flow. Shock valves are factory preset pressure regulating check valves.

In some applications of the P Series Pumps, it is desirable to move the machine for short distances at low speeds without operating the engine. A screw-type bypass valve is utilized in the pumps to permit movement of the machine. The bypass valve is fully opened when unscrewed two (2) turns maximum. The bypass valve allows oil to be routed from one side of the pump/motor circuit to the other, thus allowing the motor to turn with minimal resistance. An increase in resistance will occur with movement at higher speeds. The bypass valve must be fully closed during normal operation.



WARNING

Actuating the bypass will result in the loss of hydrostatic braking capacity. The machine must be stationary, on a level surface and in neutral when actuating the bypass.

Additionally, some pumps may be equipped with an Auxiliary Pump. The Auxiliary incorporates the principles of the charge gerotor assembly and provides the capability of an external auxiliary flow for an alternate hydraulic circuit to operate accessories without loss of drive.

EXTERNAL FEATURES - PC SERIES

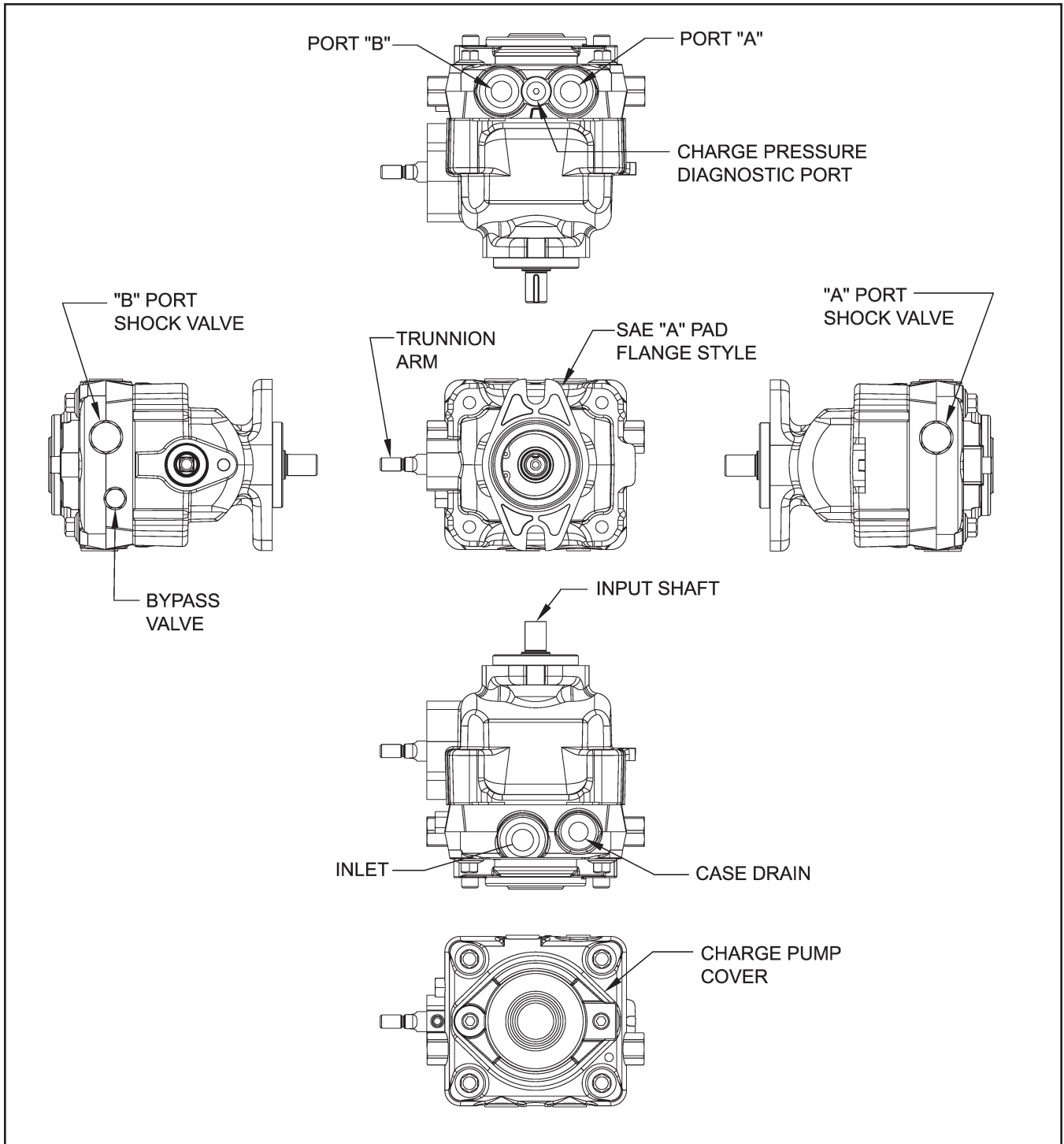

Figure 1. PC Pump with Standard Charge Pump

EXTERNAL FEATURES - PG / PE SERIES

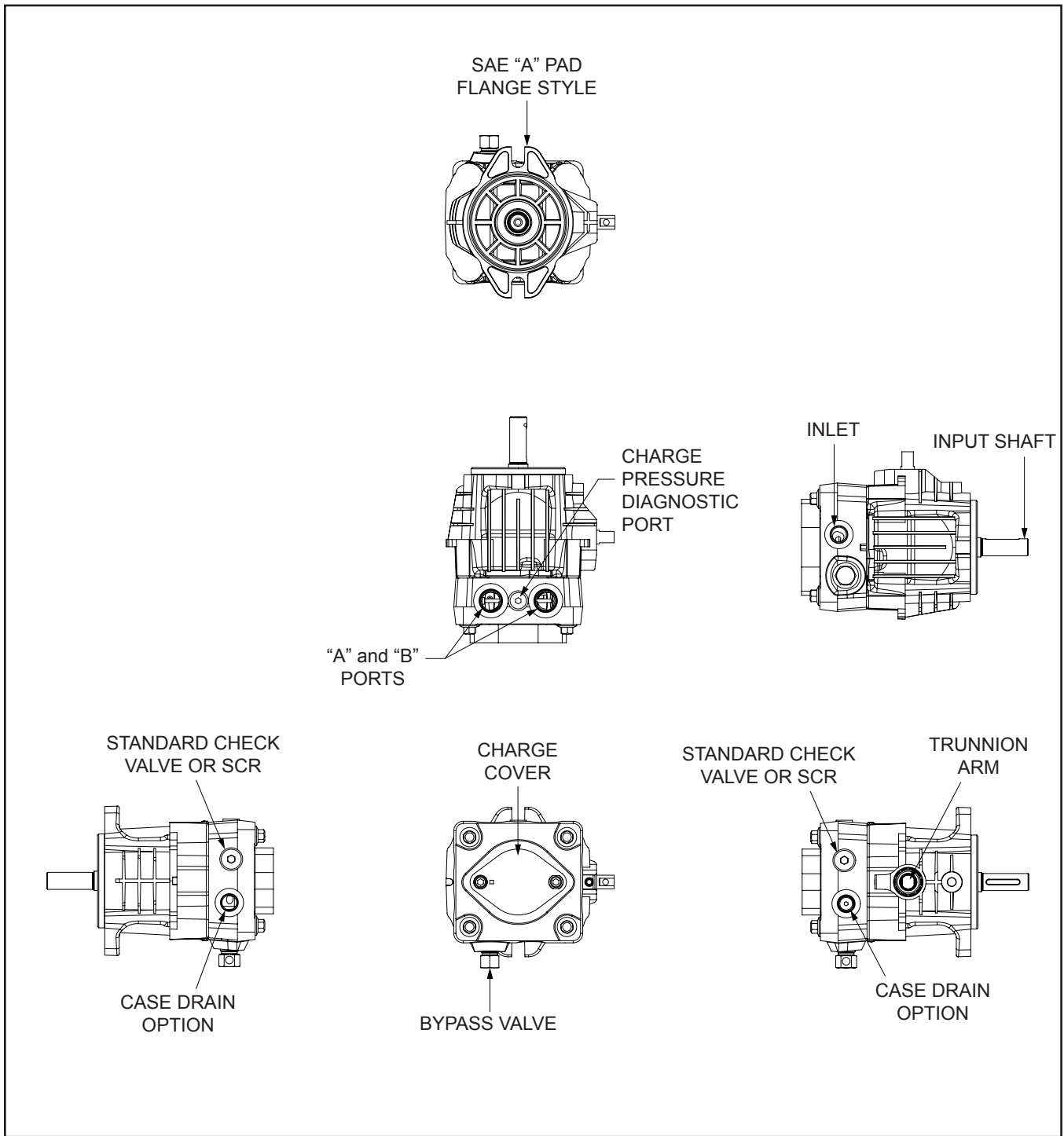

Figure 2. PG Pump With Standard Charge Pump

EXTERNAL FEATURES - PJ SERIES

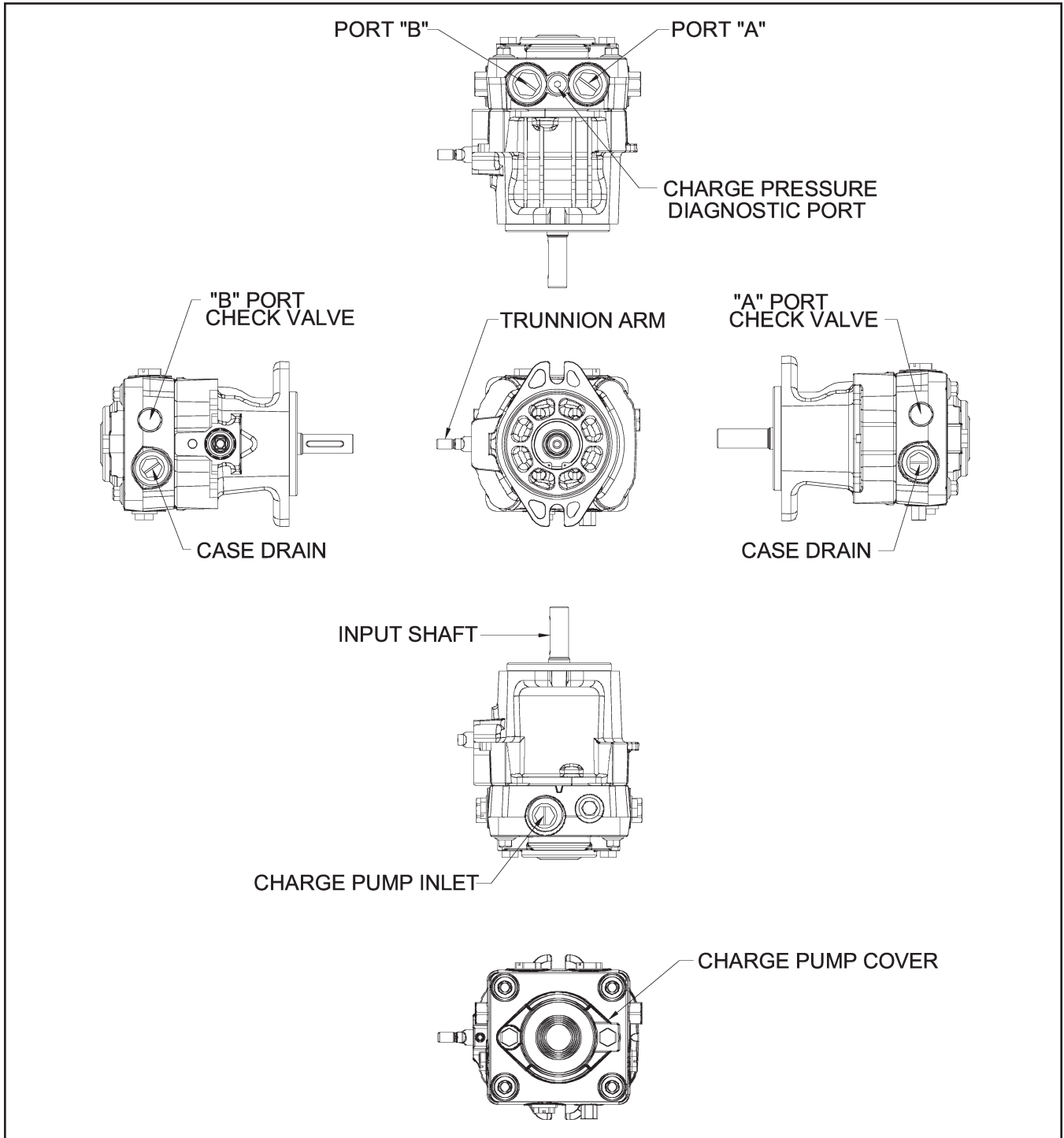

Figure 3. PJ Pump with Standard Charge Pump

EXTERNAL FEATURES - PK SERIES

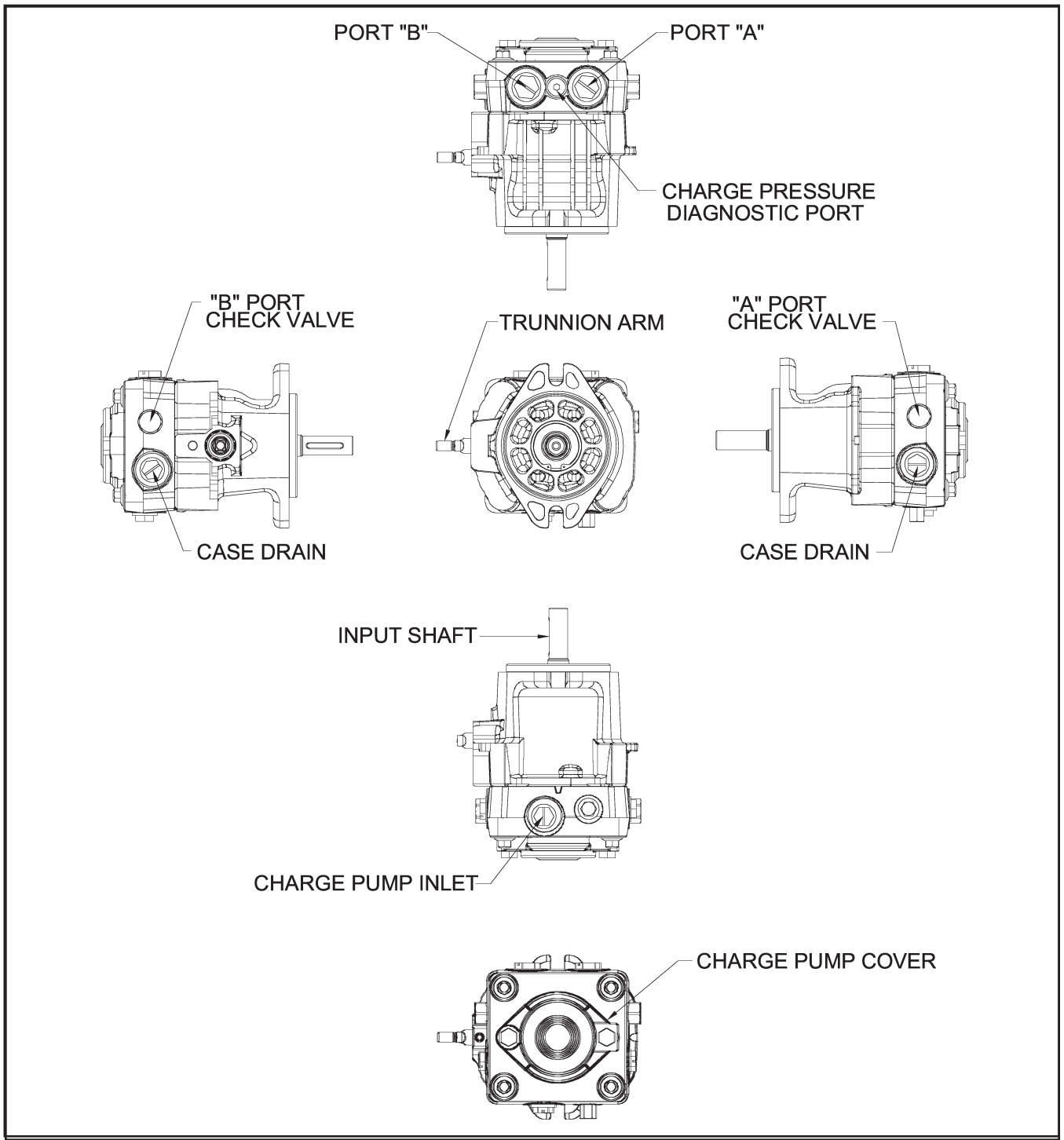

Figure 4. PK Pump With Standard Charge Pump

EXTERNAL FEATURES - PR SERIES

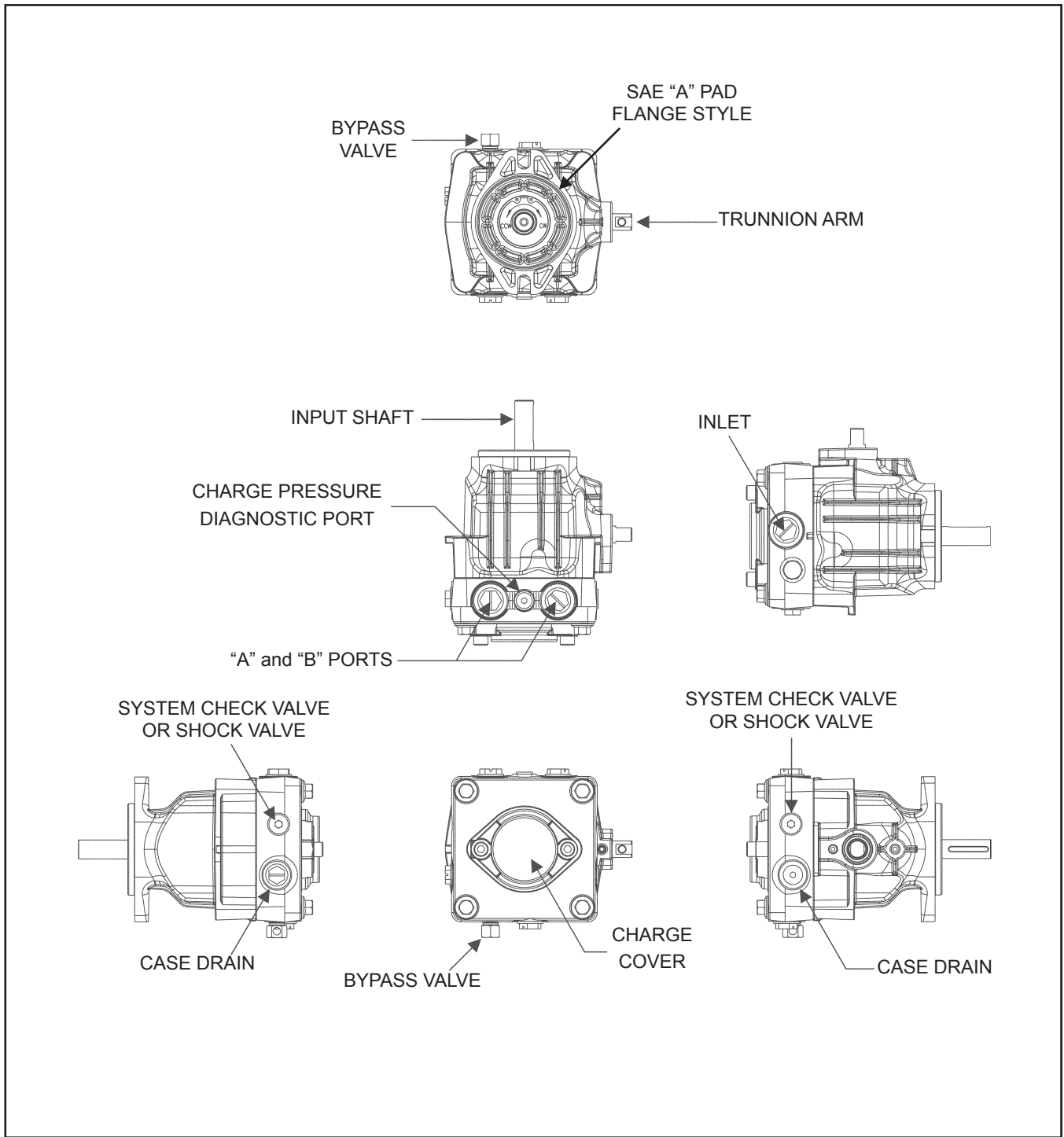

Figure 4. PR Pump With Standard Charge Pump

EXTERNAL FEATURES - PW / PY SERIES

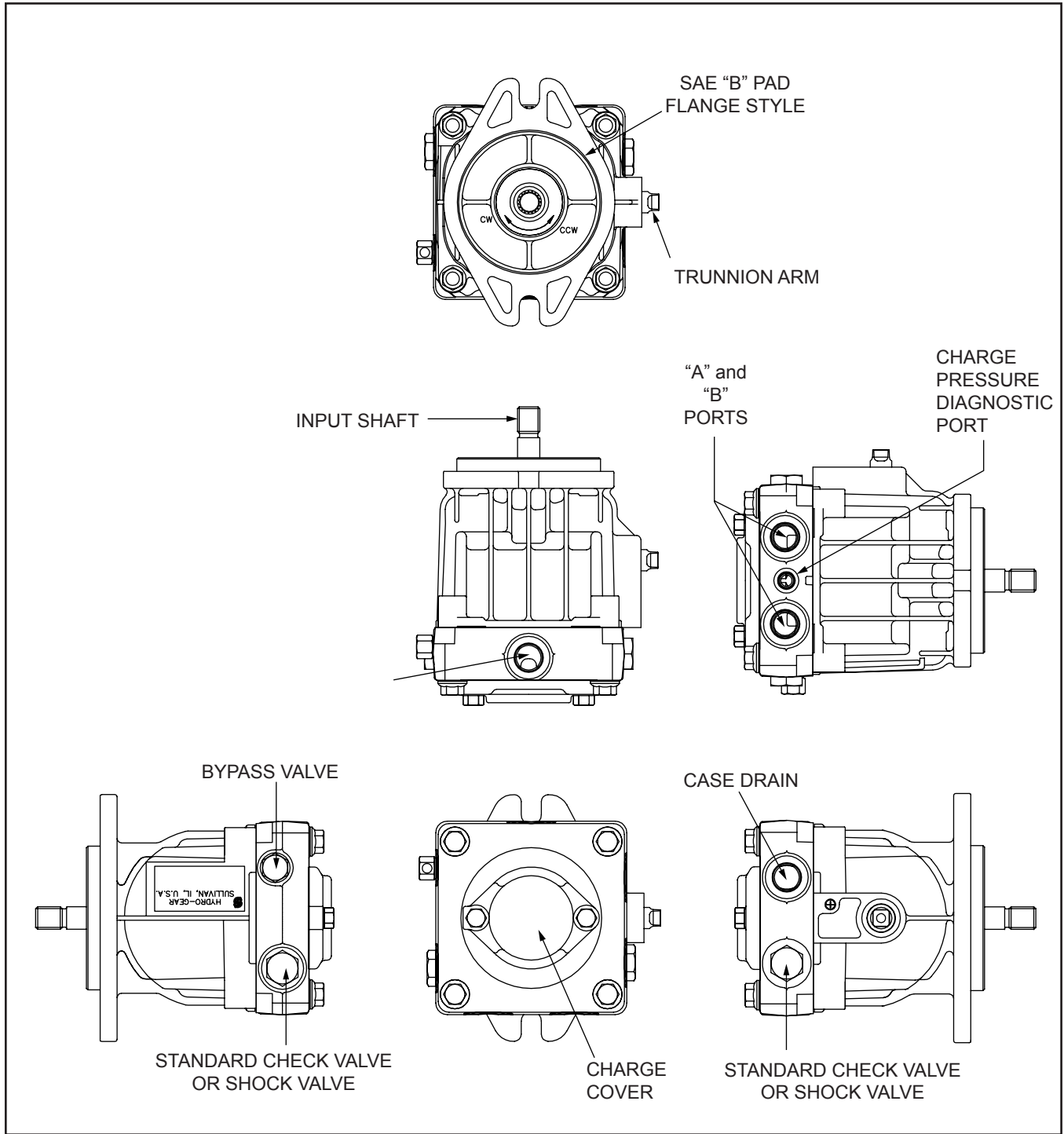

Figure 5. PW / PY Pump With Standard Charge Pump

HYDRAULIC SCHEMATIC

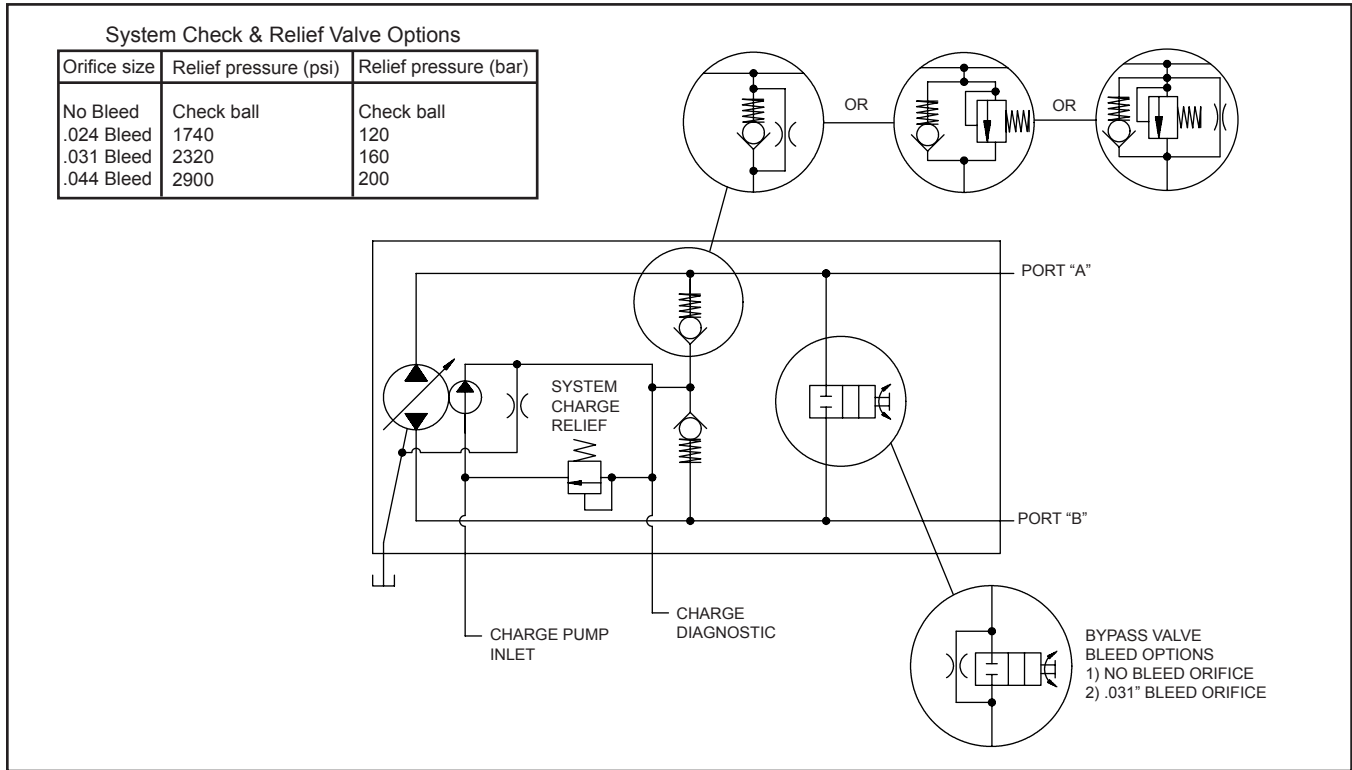

Figure 6. PC, PG, PJ, PK and PR Pumps with Standard Charge Pump

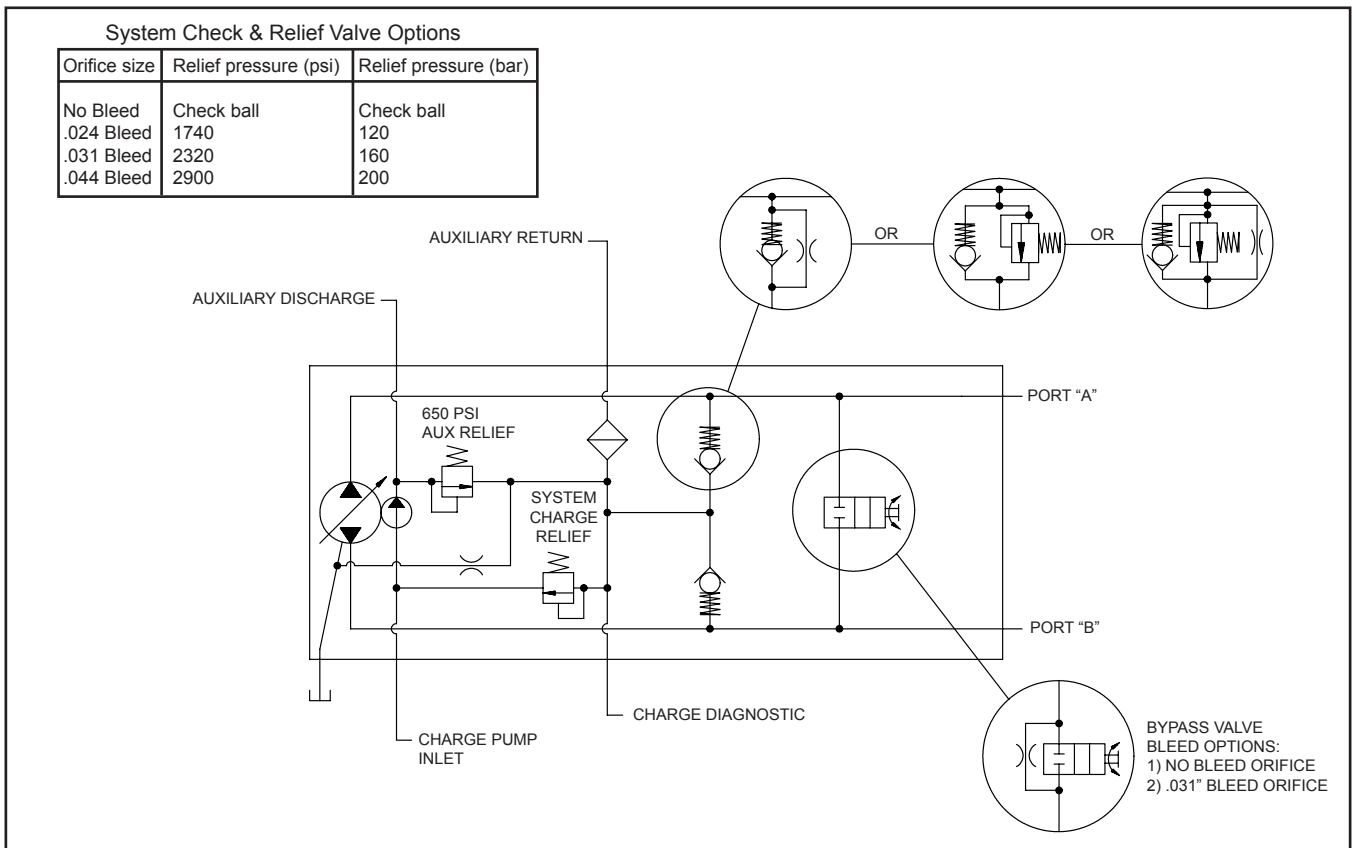

Figure 7. PC, PG, PJ, PK and PR Pumps with Auxiliary Charge Pump

HYDRAULIC SCHEMATIC

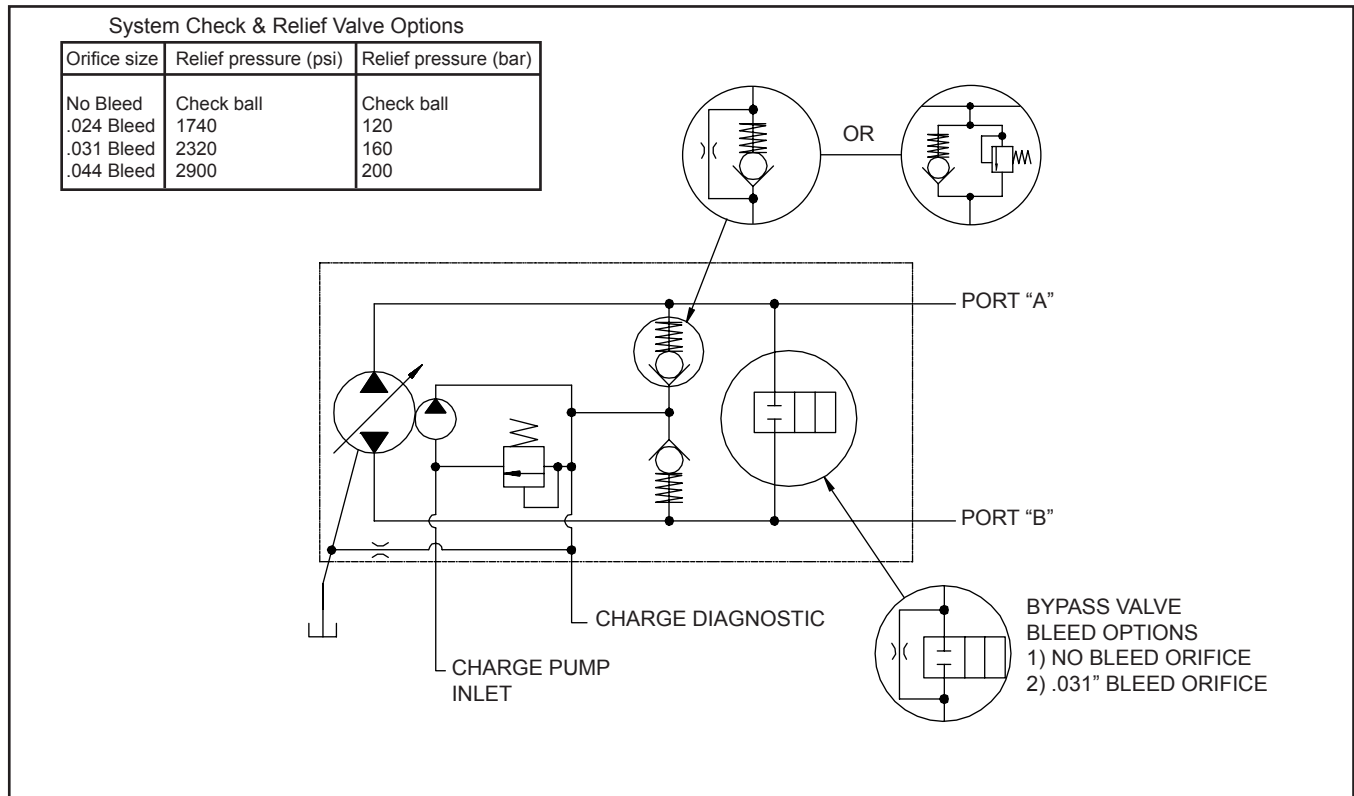

Figure 8. PW / PY Series Pump With Standard Charge Pump

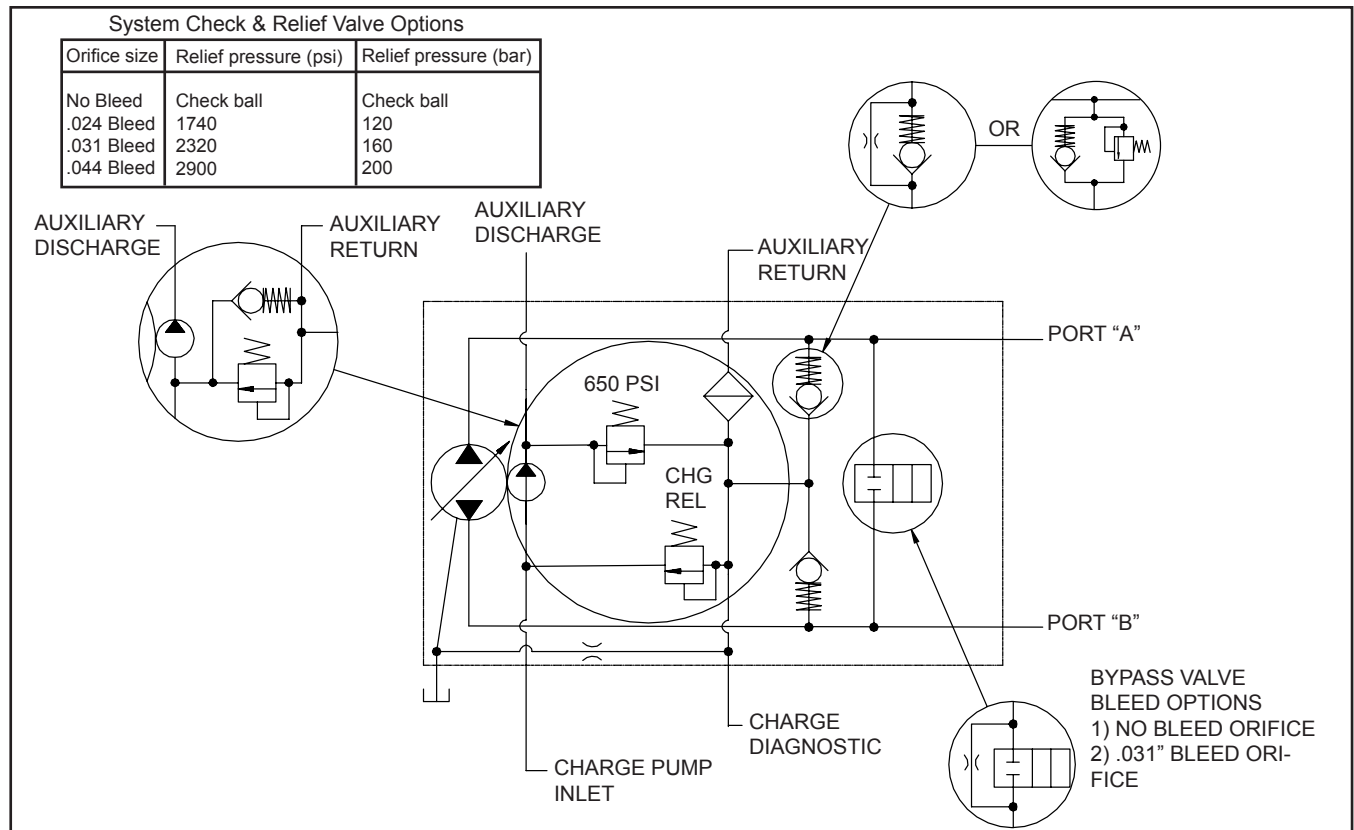

Figure 9. PW / PY Series Pump With Auxiliary Charge Pump

GRAPHICAL SCHEMATIC

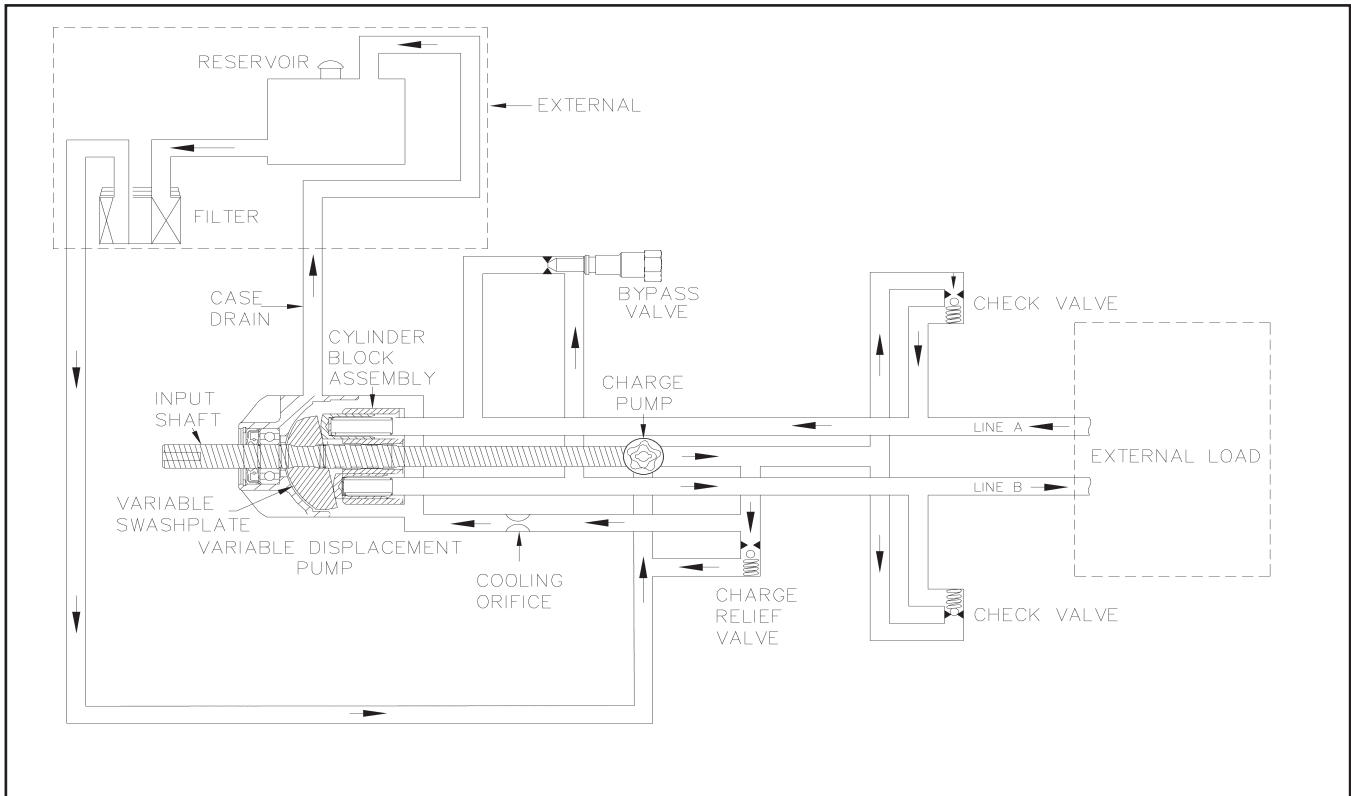

Figure 10. P Series Pump With Standard Charge Pump

Figure 10 represents a graphical schematic of the P Series Pump with standard charge pump. Figure 10 provides a graphical illustration of the hydraulic oil circuit.

The input shaft and pump cylinder block are turned in one direction only by the engine/drive belt/pulley combination or direct drive gear box.

The oil is drawn through an external filter by the charge pump. The filter prevents contaminants within the reservoir from entering into the charge pump gerotor.

The charge pump supplies fluid to keep the closed loop pressurized, preventing cavitation and providing cooling oil flow for the system.

The charge relief valve is used to maintain charge at a predetermined pressure.

Output of the system oil flow is controlled by the direction and amount that the swashplate is angled. As the pump pistons compress, they force oil into one of two passageways ("A" or "B") in the system hydraulic circuit. Oil is supplied externally under pressure to an external load, (e.g., a vehicle wheel motor).

As the angle of the pump swashplate is increased, the amount of oil being pumped will increase and cause a higher speed output of the wheel motor. Reversing the angle of the swashplate will reverse the direction of the oil flow. During the operation of the pump, fluid is "lost" from the hydraulic loop through leak paths designed into the product for lubrication and cooling purposes (around pistons, under the rotating cylinder block, etc.). This "lost" fluid returns to the reservoir through the case drain. This fluid must be made up in the loop. The charge pump makes up this fluid loss.

The makeup flow is controlled (or directed) by the system check valves. The check valves are used to direct makeup fluid into the low pressure side of the closed loop. Each check valve will either be held open or closed, depending upon the direction of the vehicle operation: Closed in a pressurized system passage, open in a low pressure, "charged" system passage.

TECHNICAL SPECIFICATIONS

Product Type	PC	PG/PE	PJ/PK	PR	PW/PY	PY 6cc Aux
Displacement in ³ /rev [cc/rev]	0.37 [6.1]	0.62 [10.2]	0.73 [12]	0.97 [16]	1.33 [21.8]	
Input Speed Maximum Unloaded RPM Minimum Loaded RPM	3600 1800					
System Operating Pressure Continuous psi [bar]	750 [51]	1000 [75]		1250[86]		
Intermittent psi [bar]	1750 [120]	2100 [145]		2500 [172]		
Peak psi [bar]	2500 [172]	3500 [240]		3750 [260]		
Pump Performance @2400 rpm/1000 psi gpm [l/min] @3000 rpm/1000 psi gpm [l/min] @3600 rpm/1000 psi gpm [l/min]	3.6 [13.6] 4.5 [17.0] 5.4 [20.4]	6.1 [23.1] 7.6 [28.8] 9.2 [34.8]	7.1 [26.8] 8.9 [33.6] 10.8 [40.8]	9.6 [36.3] 12 [45.4] 14.4 [54.5]	13.1 [49.6] 16.4 [62.1] 19.6 [74.2]	
Case Pressure Maximum @ Cold Start psi [bar] Continuous - Max. psi [bar]						
Inlet Vacuum Maximum Continuous Inches Mercury	4					
Charge Pump Displacement(s) in ³ /rev [cc/rev]	0.13 [2.1]	0.11/0.13 [1.9/2.1]	0.19 [3.2]	0.13/0.19 [2.1/3.2]		0.25 [4.1]
Auxiliary Pump Displacement in ³ /rev [cc/rev]	0.19 [3.2]					0.37 [6.1]
Auxiliary Pump Relief Setting psi [bar]	650 [45]					950-1400 [65.5-96.5]
Auxiliary Pump Performance @3200 rpm, 500 psi, 70 SUS [13 Cst] oil, & 180°F gpm [l/min]	1.8-2.0 [6.8-7.6]					4.4-5.0 [16.6-18.9]
Control Torque Required to Stroke Pump [Approximate - 20° External Stroke Angle] lb-in / 1000 psi [N-m / 70 bar] lb-in / 500 psi [N-m / 35 bar]	75 [8.5] 55 [6.2]	85 [9.6] 60 [6.8]	95 [10.7] 75 [8.5]	105 [11.9] 85 [9.6]		
Pump Oil Temperature Maximum Intermittent (hottest point) °F [°C] Normal Operating Range °F [°C]	230 [110] -10 to 200 [-23 to 93]					
Fluid Viscosity Limits @ 230°F [110°C] Optimum SUS [cSt] Minimum SUS [cSt]	70 [13] 55 [9]					
Weight of Unit lbs [kg]	7 [3.2]	8 [3.6]	12.65 [5.7]	12 [5.4]	14 [6.3]	17 [7.7]
Inlet Filtration Requirement Nominal micron	25					

Table 1: P Series Pump Technical Specifications

PRODUCT IDENTIFICATION

The label in Figure 11 is located on the pump housing. It identifies the model and configuration of the pump.

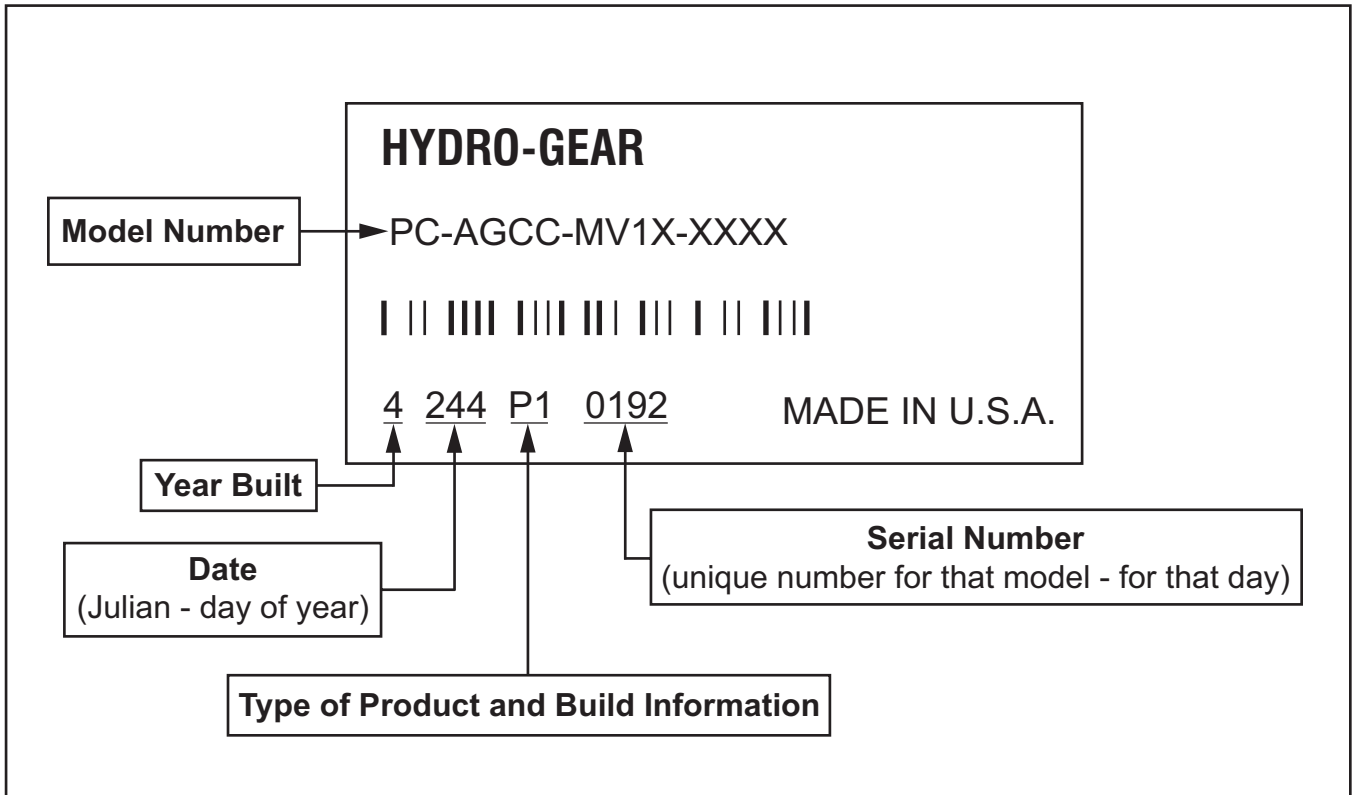



Figure 11. P Series Pump Configuration Label

SECTION 2. SAFETY

 This symbol points out important safety instructions which, if not followed, could endanger the personal safety and/or property of yourself and others. Read and follow all instructions in this manual before attempting maintenance on your P Series Pump. When you see this symbol - **HEED ITS WARNING.**

<p> WARNING</p> <p>POTENTIAL FOR SERIOUS INJURY</p> <p>Inattention to proper safety, operation, or maintenance procedures could result in personal injury, or damage to the equipment. Before servicing or repairing the P Series Pump, read fully and understand the safety precautions described in this section.</p>

PERSONAL SAFETY

Certain safety precautions must be observed while servicing or repairing the P Series Pump. This section addresses some of these precautions but must not be considered an all-inclusive source on safety information. This section is to be used in conjunction with all other safety material which may apply, such as:

- Other manuals pertaining to this machine
- Local and shop safety rules and codes
- Governmental safety laws and regulations

Be sure that you know and understand the equipment and the hazards associated with it. Do not place speed above safety.

Notify your supervisor whenever you feel there is any hazard involving the equipment or the performance of your job.

Never allow untrained or unauthorized personnel to service or repair the equipment.

Wear appropriate clothing. Loose or hanging clothing or jewelry can be hazardous. Use the appropriate safety equipment, such as eye and hearing protection, and safety-toe and slip-proof shoes.

Never use compressed air to clean debris from yourself or your clothing.

TOOL SAFETY

Use the proper tools and equipment for the task.

Inspect each tool before use and replace any tool that may be damaged or defective.

WORK AREA SAFETY

Keep the work area neat and orderly. Be sure it is well lit, extra tools are put away, trash and refuse are in the proper containers, and dirt or debris have been removed from the working areas of the machine.

The floor should be clean and dry, and all extension cords or similar trip hazards should be removed.

SERVICING SAFETY

Certain procedures may require the vehicle to be disabled in order to prevent possible injury to the servicing technician and/or bystanders.

The loss of hydrostatic drive line power may result in the loss of hydrostatic braking capability.

Some cleaning solvents are flammable. Use only approved cleaning materials: Do not use explosive or flammable liquids to clean the equipment.

To avoid possible fire, do not use cleaning solvents in an area where a source of ignition may be present.

Discard used cleaning material in the appropriate containers.

SECTION 3. TROUBLESHOOTING



WARNING

Do not attempt any servicing or adjustments with the engine running. Use extreme caution while inspecting the drive belt assembly and all vehicle linkage!

Follow all safety procedures outlined in the vehicle owner's manual!

In many cases, problems with the P Series Pump are not related to a defective pump but are caused by slipping drive belts, partially engaged bypass valves, and loose or damaged control linkages. Be sure to perform all operational checks and adjustments outlined in Section 3 before assuming the pump is malfunctioning. Table 2 below provides a troubleshooting checklist to help determine the cause of operational problems.

Possible Cause	Corrective Action
VEHICLE DOES NOT DRIVE/TRACK STRAIGHT	
Vehicle tires improperly inflated	Refer to vehicle manufacturer suggested pressure
Control linkage bent, loose or out of adjustment	Repair, adjust or replace vehicle linkage
Bypass loose	Tighten pump bypass per External Maintenance step 9, page 17
Inlet Leak	Check all external lines and connections to pump inlet
UNIT IS NOISY	
Excessive input speed	Adjust input speed above 1800 rpm and below 3600 rpm
Oil level low or contaminated oil	Fill reservoir to proper level or change oil
Excessive loading	Reduce vehicle load
Air trapped in hydraulic system	Purge hydraulic system per Purging Procedures on page 18
Bypass loose	Tighten pump bypass per External Maintenance step 9, page 17
Inlet leak, line or filter partially blocked or damaged	Check all external lines and connections and filter to pump inlet

Table 2. Pump Troubleshooting Checklist

Possible Cause	Corrective Action
UNIT HAS NO/LOW POWER	
Engine speed low	Adjust to correct rpm setting
Control linkage bent, loose or out of adjustment	Repair or replace vehicle linkage
Drive belt slipping or pulley damaged	Repair or replace drive belt or pulley
Oil level low or contaminated oil	Fill reservoir to proper level or change oil
Excessive loading	Reduce vehicle load
Bypass loose	Tighten pump bypass per External Maintenance step 9, page 17
Air trapped in hydraulic system	Purge hydraulic system per Purging Procedures on page 18
Inlet leak	Check all external lines and connections to pump inlet
Inlet filter clogged	Replace inlet filter
Suspected internal damage	Check pump by performing Flow Test on page 15
UNIT OPERATING HOT	
Debris buildup	Remove debris from pump and fan
Cooling fan or heat exchanger damaged	Repair or replace cooling fan or heat exchanger
Oil level low or contaminated oil	Fill reservoir to proper level or change oil
Excessive loading	Reduce vehicle load
Air trapped in hydraulic system	Purge hydraulic system per Purging Procedures on page 18
Inlet leak	Check all external lines and connections to pump inlet
PUMP LEAKS OIL	
Damaged seals and gaskets	Remove debris, replace seals
Air trapped in hydraulic system	Purge hydraulic system per Purging Procedures on page 18

P-SERIES FLOW TEST KIT INSTRUCTIONS - BLN-51334 April 2011
(This Instruction Sheet supersedes all previous flow testing instruction)

Description: P Series Flow Test Kit (Part Number 70661)

(Part Number 70661 Supersedes Part Numbers 70511 and BB-76810)

Purpose: The design purpose of the P Series Flow Test Kit is to allow the customer to isolate the pump from the wheel motor and determine if the pump is acceptable. The following information can be used to install and test the pump by simulating a wheel motor load.



WARNING

CERTAIN PROCEDURES REQUIRE THE VEHICLE ENGINE TO BE OPERATED AND THE VEHICLE TO BE RAISED OFF OF THE GROUND. TO PREVENT POSSIBLE INJURY TO



WARNING

DO NOT ATTEMPT ANY ADJUSTMENTS WITH THE ENGINE RUNNING. USE EXTREME CAUTION WHILE WORKING IN OR AROUND ALL VEHICLE LINKAGE!

INSTALLATION AND TESTING PROCEDURES:

1. Disconnect the system hoses at the wheel motor, or system hoses from the pump and connect the P Series Flow Test Kit. (Special care should be taken to prevent contamination debris from entering pump or wheel motor system ports).

Note: Using the Bi-Directional Flow Test Kit, determination of directional flow is not necessary. The flow meter may be connected in either direction into the forward and reverse high pressure system lines.

CAUTION: Ensure all fittings and hoses are attached securely. This test is being completed on the vehicle's high pressure system lines. Failure to perform this properly could result in bodily injury.

TESTING PROCEDURES:

1. Raise the drive tires off the ground. Block the remaining tires on the ground to prevent accidental vehicle movement.
2. Open the restriction valve all the way.
3. Make certain all external pump directional control stops are removed or backed off on the vehicle linkage to obtain full pump directional control arm travel.
4. Start the engine and engage the drive pulley if necessary.
5. Bring the engine to maximum operating speed.
(This should not exceed 3600 rpm input speed on the PC, PL, PG, PE, PJ and PK Series pumps)
(This should not exceed 3400 rpm input speed on the PR Series pumps)
(This should not exceed 2600 rpm input speed when testing the PW and PY Series pumps)
Engine speed adjustment may be necessary to obtain 2600 rpm.

CAUTION: Damage to the flow meter and/or re-calibration may result from testing at input speeds that exceed 2600 rpm on the PW and 3400 rpm on the PR Pumps.

6. With the directional control lever (on the vehicle) for the pump being tested, move the control arm in full forward motion. (It may be necessary to lock the control arm into full forward position to prevent false readings).
7. Operate without any load for approximately 30 seconds to 1 minute. This allows the system oil temperature to rise.

Note: Raising the system oil temperature will make a difference in the readings you receive. It has been determined that to complete this test accurately, the oil temperature must be near system operating temperatures. Suggested temperature range is 160° - 210°F (71.1° - 98.9°C).

8. On the PC, PG, PJ, PE, PK, PL, PR, PW and PY, tighten the flow meter restriction valve until the gauge reads 300 psi (21bar). Record the flow reading on the Bi-Directional Flow Meter.
9. Increase the pressure to 1100 PSI (76 bar) for all models (PC, PG, PJ, PE, PK, PL, PR, PW and PY). Record the flow reading on the Bi-Directional Flow Meter.
10. The acceptable gpm “flow droop” or (difference) is:

PC	1.0 gpm (3.7 l/min)
PG/PL/PE	1.5 gpm (5.6 l/min)
PJ/PK	2.0 gpm (7.6 l/min)
PR	2.5 gpm (9.4 l/min)
PW/PY	2.5 gpm (9.4 l/min)

If the difference exceeds these values the pump would not be operating efficiently and should be repaired or replaced.

TEST EXAMPLE: PE/PG/PL

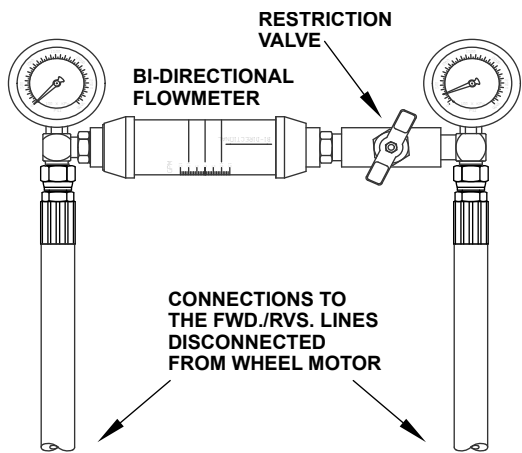

300 psi (21 bar) reading 7 gpm (26 l/min) (1st reading)

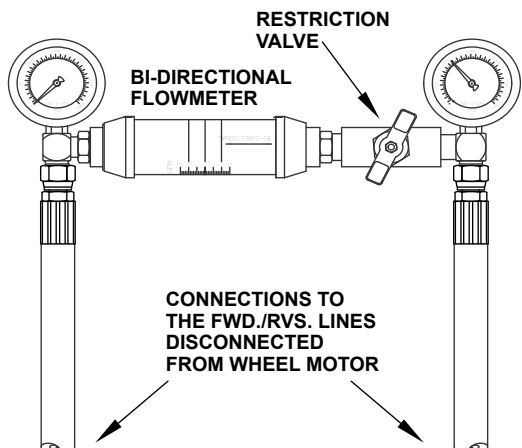

1100 psi (76 bar) reading 3 gpm (11 l/min) (2nd reading)

(PG/PL)
 300 psi (21 bar) reading 7 gpm (26 l/min) (1st reading)
 1100 psi (76 bar) reading - 3 gpm (11 l/min) (2nd reading)

 4 gpm (15 l/min) (the difference)

Subtract the 1st reading from the 2nd.
 (In this example, 4 gpm difference would indicate further pump examination).

SECTION 4. SERVICE AND MAINTENANCE

NOTE: Any servicing dealer attempting a warranty repair must have prior approval before conducting maintenance of a Hydro-Gear product, unless the servicing dealer is a current authorized Hydro-Gear Service Center.

EXTERNAL MAINTENANCE

Regular external maintenance of a P Series Pump should include the following:

1. Check the vehicle operator's manual for the recommended load ratings. Insure the current application does not exceed load rating.
2. Check fluid level in reservoir in accordance with vehicle manufacturer's recommendations.

NOTE: After the oil has been drained and maintenance has been performed, clean oil should be poured directly into the pump inlet and high pressure ports prior to plumbing connections and pump start-up.

3. Inspect the vehicle drive belt, idler pulley(s), and idler spring(s). Insure that belt slippage is not causing low input rpm to the pump.
4. Inspect all external plumbing for possible leaks or loose fittings. An air leak may be difficult to detect on the "suction side" or inlet line to the pump. Refer to Purging Procedures page 18.
5. Insure correct inlet filter(s) has been installed in accordance with the vehicle manufacturer recommendations.
6. Insure the reservoir is free of contaminants and is properly vented.
7. Inspect the P Series Pump cooling fan (if applicable) for broken or distorted blades and remove any obstructions (grass clippings, leaves or dirt). Inspect oil cooler (if applicable) for damaged fins and debris.

8. Inspect the vehicle control linkage to the directional control arm on the P Series Pump. Also, insure the control arm is securely fastened to the trunnion arm.
9. Inspect the bypass on the P Series Pump to insure it is properly engaged for operation. If the bypass is not fully engaged (rotated fully clockwise) it will not function properly. For vehicle movement without engine power, the bypass may be backed out (2) turns maximum. This is only recommended for movement of short distances at low speeds.



WARNING

Loosening the bypass will result in loss of hydraulic braking capability.

SERVICE AND MAINTENANCE PROCEDURES

NOTE: Damage to P Series Pumps may result from external or internal contamination, heat from excess debris or lack of lubrication and over-pressurization of the hydrostatic system. Follow guidelines established in this manual and the vehicle manufacturer's recommendations.

All the service procedures presented on the following pages can be performed while the P Series Pump is mounted on the vehicle. Any servicing beyond those presented in this section must be performed after the pump has been removed from the vehicle.

FLUIDS

The fluids used in Hydro-Gear products have been carefully selected, and only equivalent, or better products should be substituted.

Typically, an engine oil with a minimum rating of 55 SUS (9.0 cSt) at 230° F (110° C) maximum operating temperature and an API classification of SJ/CD is allowed. Refer to the vehicle manufacturer for recommended oil.

FLUID VOLUME AND LEVEL

Certain situations may require additional fluid to be added or even replaced. Refer to the vehicle manufacturer's recommendations for the proper fill location and level. After maintenance or oil change, follow purging procedures below and check the fluid level once the unit has been operated for approximately 1 minute.

FLUID CHANGE

In the event of oil contamination or degradation, oil addition or change may alleviate certain performance problems. Refer to the vehicle manufacturer's recommended oil change frequency. Refer to purging procedures below after changing fluids.

FILTERS

An inlet filter is required to insure that only clean fluid enters the system. Refer to the vehicle manufacture for approved filter replacement.

PURGING PROCEDURES

Due to the effects air has on efficiency in hydrostatic drive applications, it is critical that air is removed or purged from the system.

These purge procedures must be preformed anytime a hydrostatic system has been opened for maintenance or repair, or if any additional oil has been added to the system.

Air creates inefficiency because it has compression and expansion rates that are higher than that of oil.

Air trapped in the oil may cause the following symptoms:

1. Noisy operation.
2. Lack of power or drive after short-term operation.
3. High operation temperature and excessive expansion of oil.

Before starting, make sure the reservoir is at the proper oil level. If it is not, fill to the vehicle manufacturer's specifications.

The following procedures should be performed with the vehicle drive wheels off the ground, then repeated under normal operating conditions.



WARNING

POTENTIAL FOR SERIOUS INJURY

Certain procedures require the vehicle engine to be operated and the vehicle to be raised off of the ground. To prevent possible injury to the servicing technician and/or bystanders, insure the vehicle is properly secured.

1. With the bypass valve open and the engine running, slowly move the directional control in both forward and reverse directions (5 to 6 times). As air is purged from the unit, the oil level in the reservoir will drop.
2. With the bypass valve closed and the engine running, slowly move the directional control in both forward and reverse directions (5 to 6 times). Check the oil level, and add oil as required after stopping engine.
3. It may be necessary to repeat steps 1 and 2 until all the air is completely purged from the system. When the P Series Pump moves forward and reverse at normal speed and the reservoir oil remains at a constant level, purging is complete.

Cleanliness is a key factor in the successful repair of pumps. Thoroughly clean all exposed surfaces prior to any type of maintenance. Cleaning of all parts by using a solvent wash and air drying is usually adequate. As with any precision equipment, all parts must be kept free of foreign material and chemicals. Protect all exposed sealing areas and open cavities from damage and foreign material.

Upon removal, all seals, O-rings, and gaskets should be replaced. During installation, lightly lubricate all seals, O-rings, and gaskets with clean petroleum jelly prior to assembly. Also protect the inner diameter of seals by covering the shaft machined features with plastic wrap or equivalent.

RETURN TO NEUTRAL SETTING



WARNING

POTENTIAL FOR SERIOUS INJURY

Inattention to proper safety, operation, or maintenance procedures could result in personal injury, or damage to the equipment. Before servicing or repairing the P Series Pump, fully read and understand the safety precautions described in this manual.



WARNING

Do not attempt any servicing or adjustments with the engine running. Use extreme caution while inspecting the drive belt assembly and all vehicle linkage!

Follow all safety procedures outlined in the vehicle owner's manual.

The return to neutral mechanism on the pump is designed to set the directional control into a neutral position when the operator releases the vehicle hand control. Follow the procedures below to properly adjust the return to neutral mechanism on the pump:

1. Confirm the pump is in the operating mode (bypass disengaged). Raise the vehicle's drive tires off the ground to allow free rotation.
2. Remove the Original Equipment Manufacturer's (OEM's) control linkage at the control arm.
3. Start the engine and increase the throttle to full engine speed.
4. Check for axle rotation. If the axle does not rotate, go to Step 5. If the axle rotates, go to Step 6.
5. Stop the vehicle's engine. Reattach and adjust the vehicle's linkage according to the vehicle owner's manual.
6. Note the axle directional movement. Stop the vehicle engine. Loosen the RTN adjustment screw until the control arm can be rotated. Rotate the control arm in the proper direction until neutral is obtained (motor shaft does not rotate). Tighten the RTN adjustment screw. Recheck according to steps 3 and 4. Refer to Figure 12.

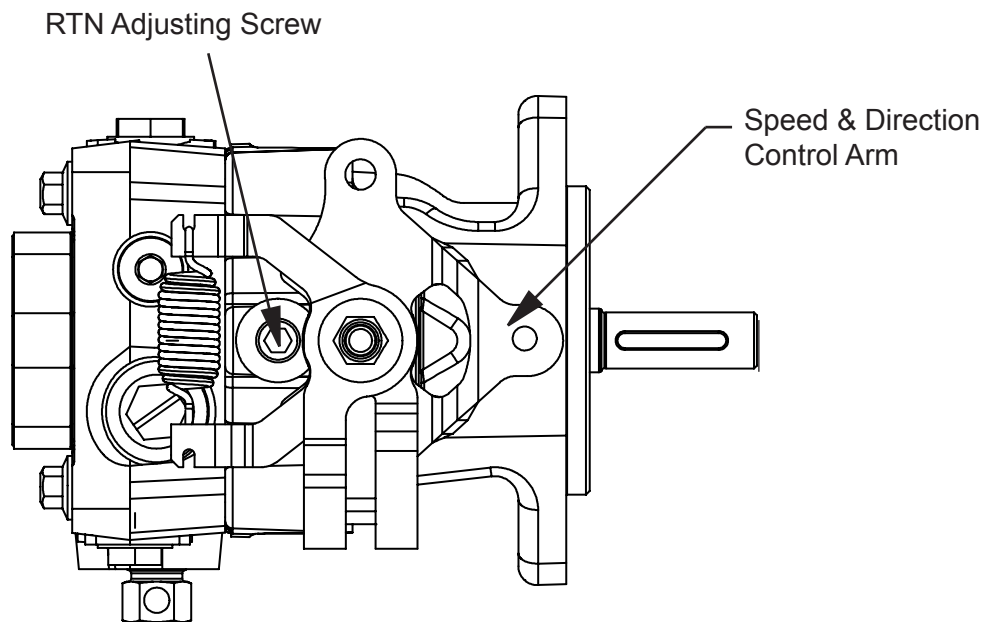

Figure 17. P Series Pump RTN Adjustment

REPAIR - PC SERIES PUMP

Repair - PC Series Pump	21-36
How to Use This Manual	21
General Instructions	21
Tools and Torques	22
Return to Neutral Linkage	23
Standard Control Arm Linkage	24
Fan Assembly	24
Input Shaft Seal	25
Trunnion Arm Seal	25
Shock Valves	26
Bypass	26
Charge Pump-Standard or Thru Shaft	27
Auxiliary Pump	28
End Cap	29
Cylinder Block	30
Block Spring and Thrust Bearings	31
Swashplate and Cradle Bearings	31
Input Shaft	32
Trunnion Arm	33
Parts List	34-35

HOW TO USE THIS MANUAL

Each assembly is provided with an exploded view showing the parts involved. **The item reference numbers in each illustration are for assembly instructions only.** See pages 34 and 35 for part names and descriptions. A complete exploded view and item list of the pump is provided at the end of this section.

GENERAL INSTRUCTIONS

Cleanliness is a primary means of ensuring satisfactory life on repaired pumps. Thoroughly clean all exposed surfaces prior to any type of maintenance. Cleaning of all parts by using a solvent wash and air drying is usually adequate. As with any precision equipment, all parts must be kept free of foreign material and chemicals.

Protect all exposed sealing surfaces and open cavities from damage and foreign material. The external surfaces should be cleaned before beginning any repairs.

Lip-type seals (shaft seals) are used on the input shaft and directional control shaft of each pump. These seals can be replaced without major disassembly of the unit. However, replacement of these seals generally requires removal of the pump from the machine. Upon removal, it is recommended that all seals, O-rings and gaskets be replaced.

During installation, lightly lubricate all seals, O-rings and gaskets with clean petroleum jelly prior to assembly. Also protect the inner diameter of the seals by covering the shaft with a cellophane (plastic wrap, etc.) material.

Parts requiring replacement must be replaced from the appropriate kits identified in the Items Listing, found at the end of this manual. Use only original Hydro-Gear replacement parts found listed in BLN-51427 (CD).

TOOLS AND TORQUES

Miscellaneous	3/8-Inch Drive Ratchet and Sockets
P Series Service & Repair Manual	7/16-inch Socket
Torque Wrench	1/2-Inch Socket
Scribe, Paint Pen, or Marker	11/16-Inch Socket
Seal Hook with a Magnet	10-mm Socket
Flat Blade Screwdriver	Combination Wrenches
Pliers	7/16 Inch
Internal Snap Ring	1/2 Inch
Allen Wrenches	11/16 Inch
1/8 inch	10 mm
1/4 inch	

Table 1. Required Tools

Item # and/or Description	Torque
Case Drain (fitting torque)	200-250 lb-in (22.6-28.2 Nm)
System Port (fitting torque)	370-470 lb-in (41.8-53.1 Nm)
Inlet (fitting torque)	200-250 lb-in (22.6-28.2 Nm)
Fan Nut, Hex Lock 5/16-24 UNF	120-160 lb-in (13.5-18.1 Nm)
4, End Cap/Adapter Plate Bolts	180-220 lb-in (20.3-24.9 Nm)
10, Cap Screw	180-220 lb-in (20.3-24.9 Nm)
15, Bypass Valve	110-130 lb-in (12.4-14.7 Nm)
42A, 42B, Shock Valves/Check Plugs	180-240 lb-in (20.3-27.1 Nm)
44, System Charge Relief Kit (Aux Chg)	180-240 lb-in (20.3-27.1 Nm)
45, Aux Relief Valve Kit	180-240 lb-in (20.3-27.1 Nm)
56, Diagnostic Plug	84-120 lb-in (9.4-13.5 Nm)
66, Filter Cover Plug	55-85 lb-in (6.2-9.6 Nm)
67, Filter Cover	200-275 lb-in (22.6-31.1 Nm)
103, Screw 5/16 x .875	200-240 lb-in (22.6-27.1 Nm)
106, Nut, Hex Lock 5/16-24 UNF	180-220 lb-in (20.3-24.9 Nm)
164, Plug, Metal 7/16-20	84-120 lb-in (9.4-13.5 Nm)

Table 2. PC Pump Torque Values

PC SERIES PUMP REPAIR

REMOVAL, INSPECTION AND/OR REPLACEMENT OF RETURN TO NEUTRAL ASSEMBLY

Refer to Figure 1.

Prior to disassembly, note the position of the scissor arm brackets and the tab on the outer control arm bracket.

Disassembly

CAUTION: The spring used on the return to neutral linkage is under tension. To avoid possible injury, use care and proper protection during disassembly and assembly of the return to neutral linkage.

1. Loosen (but do not remove) the nut (106).
2. To relieve spring tension, carefully pry up on the outer scissor control arm until it releases from the tab on the outer control arm bracket.
3. Remove the spring (102), nut (106) washer (104) and outer scissor control arm bracket.
4. Remove bushing (101), washer (105), and the inner scissor control arm bracket.
5. Remove the outer control arm bracket, bolt (103), washer (104) and the inner return arm bracket.

Inspection

1. With the arm control linkage removed, inspect the trunnion arm (37) and trunnion arm seal (49).
2. Inspect bushing (101) and all other linkage parts for damage, corrosion or wear.

Assembly

1. Install the inner return arm bracket, washer (104) and bolt (103).

NOTE: Do not over tighten the bolt (103). The bracket must move freely.

2. Install the outer control arm bracket, washer (105) and bushing (101).
3. Install the inner scissor control arm bracket, washer (105), and outer scissor control arm bracket.
4. Install washer (104), and nut (106). Tighten to the correct torque value. See page 22.
5. Install the spring (102).

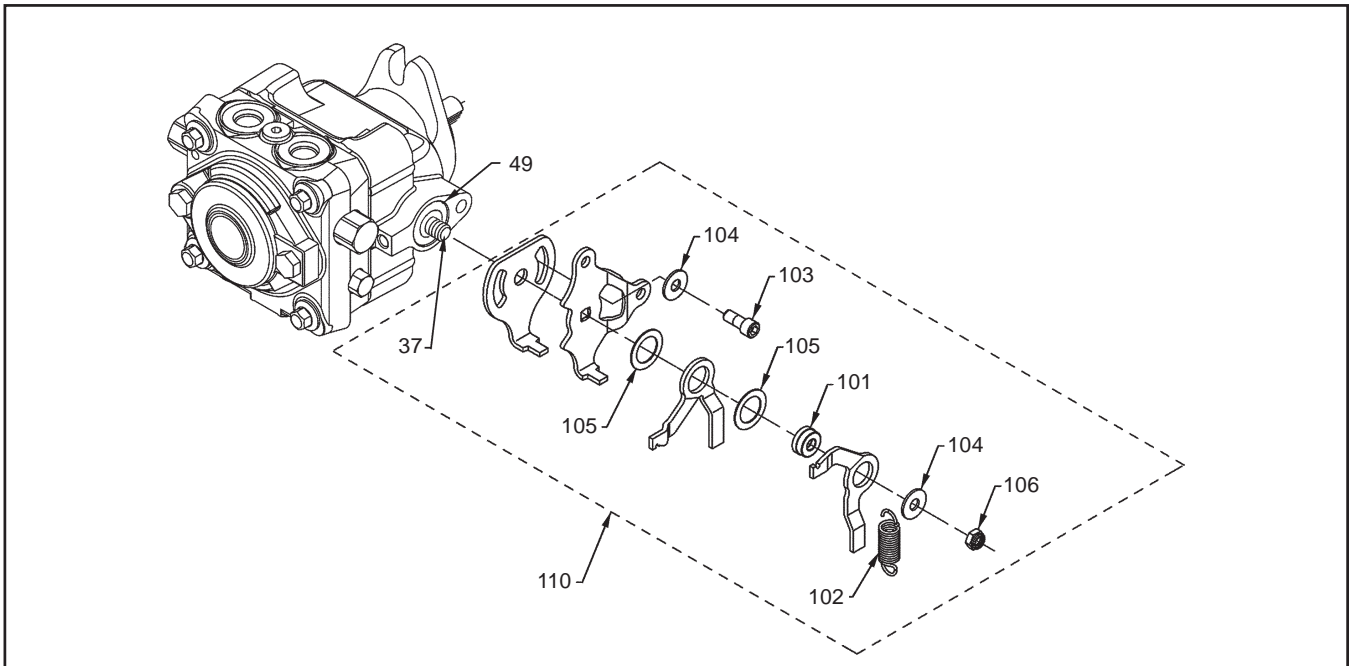

Figure 1. Return to Neutral Assembly

REMOVAL, INSPECTION AND/OR REPLACEMENT OF CONTROL ARM

Refer to Figure 2.

Disassembly

1. Remove the nut (106), washer (104) and bushing (101).
2. Remove the outer control arm bracket.
3. Remove bolt (103), washer (104) and the inner control arm bracket.

Inspection

1. With the arm control linkage removed, inspect the trunnion arm (37) and trunnion arm seal (49).
2. Inspect bushing (101) and all other linkage parts for damage, corrosion or wear.

Assembly

1. Install the inner control arm bracket, washer (104) and bolt (103).

NOTE: Do not over tighten the bolt (103). The bracket must move freely.

2. Install the outer control arm bracket, bushing (101), washer (104) and nut (106). Tighten to the correct torque value. See page 22.

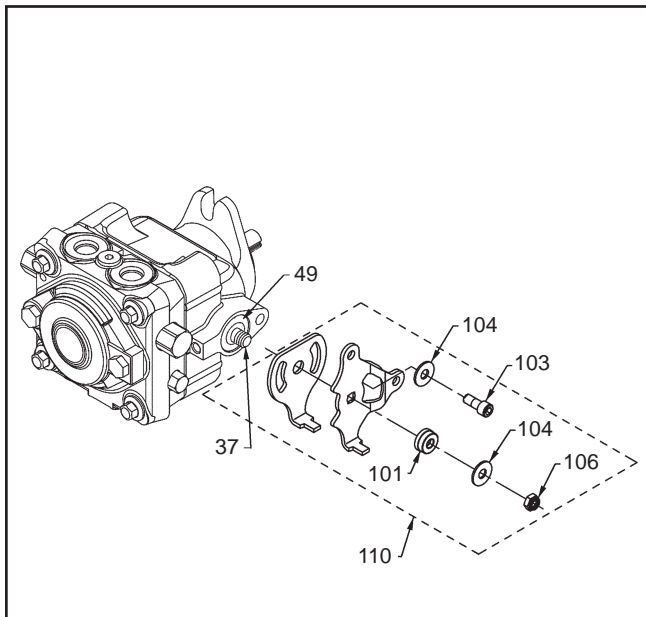

Figure 2. Standard Control Arm

REMOVAL, INSPECTION AND/OR REPLACEMENT OF FAN ASSEMBLY

Refer to Figure 3.

Disassembly

1. Remove the fan shroud (210) from the mounting bracket (209) by carefully pushing down on the shroud tabs.
2. Remove the nut (106) and fan assembly (90).
3. Remove the bolts (10) and bracket (209).

Inspection

Inspect the fan shroud (210), fan assembly (90) and mounting bracket (209) for damage.

Assembly

1. To install the mounting bracket (209), align and insert the bolts (10) into the bracket and charge pump cover. While holding the charge cover in place, tighten the bolts (10) per table 2, page 22.
2. Install the fan and washer assembly onto the shaft.
3. Install the nut (106) and tighten per table 2, page 22.
4. Install the fan shroud (210) onto the mounting bracket (209). Make sure that all shroud lock tabs are fully engaged in the mounting bracket slots.

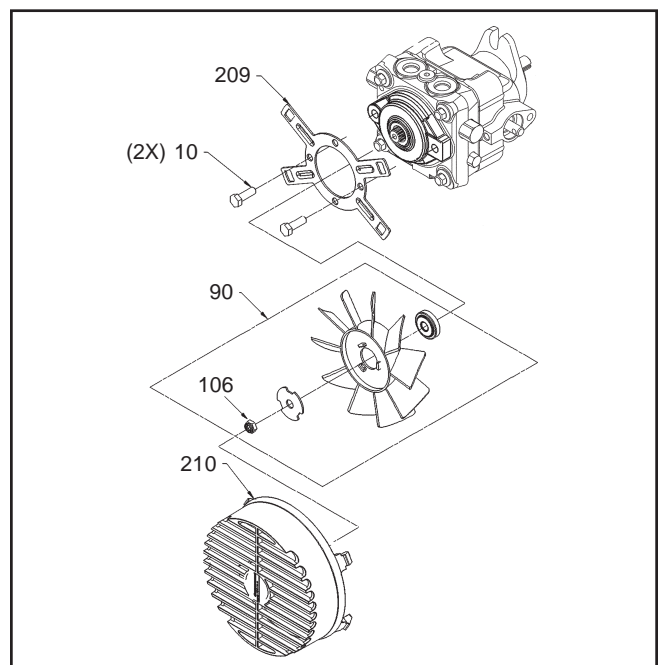

Figure 3. Fan Assembly

REMOVAL, INSPECTION AND/OR REPLACEMENT OF INPUT SHAFT SEAL

Refer to Figure 4.

Disassembly

1. Remove retaining ring (22) from housing.
2. Remove lip seal (20). Care must be taken to prevent damage to the housing bore, shaft sealing surface, or bearing. Once removed, the seal is not reusable.

Inspection

With seal removed inspect the spacer (21) and housing (1) bore for damage, corrosion or wear.

Assembly

1. Lubricate the new lip seal (20) inside diameter with petroleum jelly.
2. Wrap the input shaft (18) with plastic wrap to prevent damage to the inner surface of the lip seal (20).
3. Slide spacer (21) and seal (20) over shaft (18) so that lettering on the seal faces out.
4. Press the lip seal (20) into the housing bore. Insure the lip seal (20), shaft (18) or housing (1) bore do not become damaged. Remove the plastic wrap.
5. Install the retaining ring (22) into the housing (1) bore groove. Refer to Figure 4.

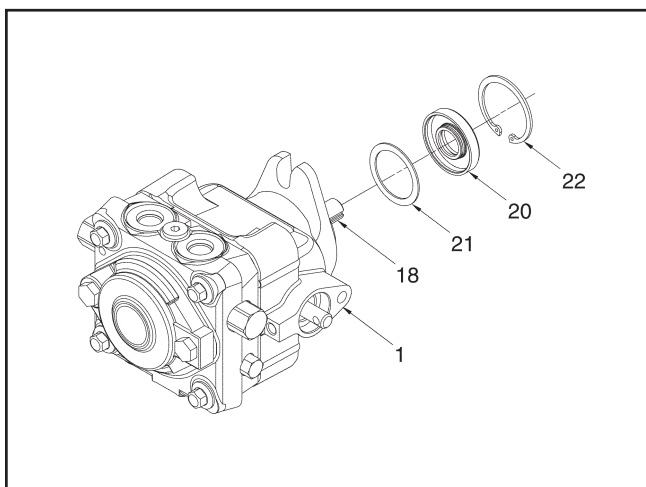

Figure 4. PC Pump Input Shaft Seal

REMOVAL, INSPECTION AND/OR REPLACEMENT OF TRUNNION ARM SEAL

Refer to Figure 5.

Disassembly

1. Remove the RTN assembly or control arm.
2. Remove the retainer and lip seal (49) from the housing. Care must be taken to prevent damage to the housing trunnion bore, trunnion arm and sealing surface. Once removed the retainer and lip seal are not reusable.

Inspection

With the lip seal (49) removed, inspect the area for corrosion and wear. Inspect the trunnion bore area sealing surface for damage or wear.

Assembly

1. Lubricate the new lip seal (49) inside diameter with petroleum jelly.
2. Wrap the trunnion arm with plastic wrap to prevent damage to the inner surface of the lip seal (49).
3. Slide the lip seal (49) over the trunnion arm so that the lettering on the seal (49) faces out.
4. Press the lip seal (49) into the housing bore. Insure the seal (49), trunnion arm, and housing bore do not become damaged. Remove plastic wrap.
5. Install the retainer from (49) over the trunnion arm on top of the lip seal. Press into the trunnion seal bore in the housing until the retainer mates against the trunnion seal.
6. Install the RTN assembly or control arm.

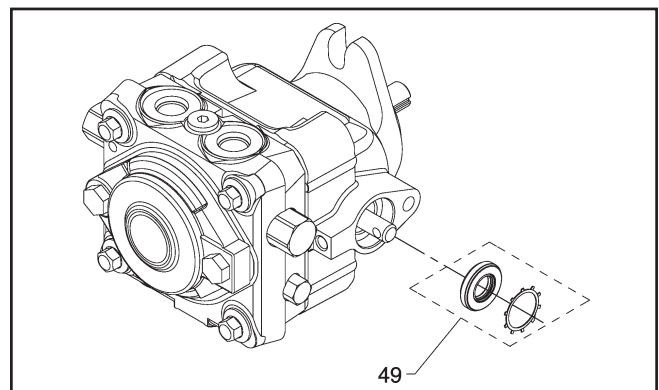

Figure 5. Trunnion Arm Seal

REMOVAL, INSPECTION AND/OR REPLACEMENT OF SHOCK VALVES

Refer to Figure 6.

Perform disassembly, inspection and assembly on shock valve one side at a time. Some units vary in “A” side to “B” side configuration.

Disassembly

1. Remove the shock valve (42) with an 11/16-inch wrench.
2. Remove the shock valve spring and the shock valve from the end cap.

Inspection

Inspect the shock valve (42) and mating seat in the end cap for damage or foreign material.

Assembly

1. Position the pump so the shock valve port is horizontal.
2. Insert the shock valve spring and shock valve as one assembly into the check plug port. Tighten to the correct torque value. See Table 2, page 22 (Torque Values).
3. Repeat disassembly, inspection and assembly for the opposite port.

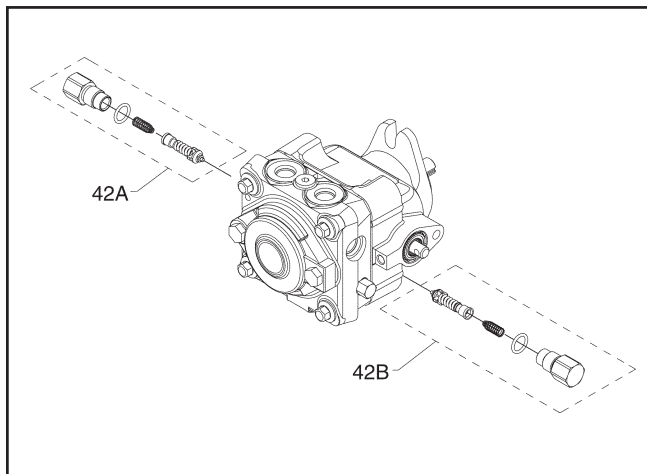

Figure 6. PC Pump Shock Valves

REMOVAL, INSPECTION AND/OR REPLACEMENT OF THE BYPASS

Refer to Figure 7.

Disassembly

1. Loosen the bypass valve (15) using a 7/16-inch wrench.
2. Remove the bypass (15) from the end cap.

Inspection

1. Inspect the bypass O-rings and mating seats in the end cap for damage or foreign material.
2. If damaged or worn, replace bypass (15).

Assembly

1. Position the pump so the bypass port is horizontal.
2. Insert the bypass (15) into the bypass port of the end cap. Tighten to the correct torque value. See Table 2, page 22 (Torque Values).

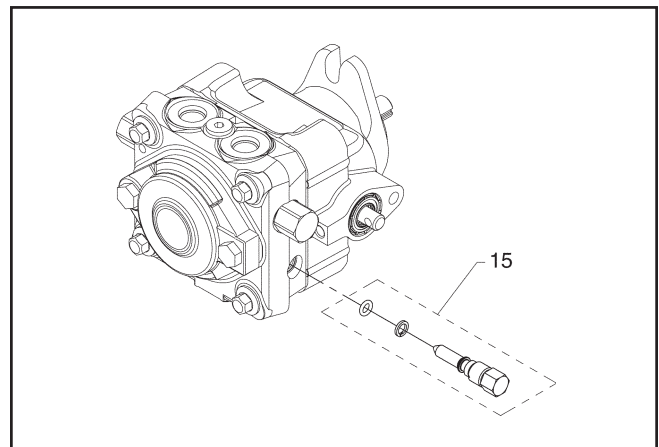

Figure 7. PC Pump Bypass

REMOVAL, INSPECTION AND ASSEMBLY OF THE STANDARD OR THRU SHAFT CHARGE PUMP

Refer to Figure 8.

Disassembly

1. Prior to removal of the charge pump cover, place a mark on the cover and end cap for alignment at assembly.
2. Using a 1/2-inch wrench, loosen the charge pump cover bolts (10) from the end cap (2). While holding the charge cover (6) in place, remove the charge cover bolts (10).
3. Remove the charge cover, O-ring (8) and gerotor items (7). Carefully check for and remove the charge spring and charge ball (44).
4. For thru shaft charge pump, remove the shaft seal.

Inspection

1. Inspect the charge cover O-ring (8) and running surfaces for damage. Inspect the spring, check ball (44), and mating seat in the end cap (2) for damage or foreign material.
2. Inspect the charge cover bore for damage corrosion or wear.

NOTE: If the end cap (2) is to be removed from the housing, do not assemble the charge pump (6) until the end cap is installed on the housing.

NOTE: For thru shaft charge pump assembly, follow steps 1 thru 8. For standard charge pump, follow steps 3 thru 8.

Assembly

1. Lubricate the new shaft seal with petroleum jelly.
2. Press the shaft seal into the charge cover. Be careful not to damage the shaft seal or charge cover bore.
3. Position the pump with the input shaft down, and the end cap (2) horizontal. Place the charge ball (44) in the end cap (2) charge passage so the ball mates to the end cap (2) charge ball seat. Place the charge spring, on top of the charge ball.
4. Insert the inner gerotor over input shaft (18).
5. Align the outer gerotor to fit over the inner gerotor.
6. Insert the O-ring (8) into the groove in the charge cover.
7. Position the charge cover and O-ring with the aligning mark on the end cap. Place the charge cover and O-ring as one piece over the charge spring and gerotor assembly. Insure the spring fits into the charge cover spring retaining groove.
8. Align and insert the charge pump cover bolts (10) into the end cap (2). Tighten to the correct torque value. See Table 2, page 22 (Torque Values).

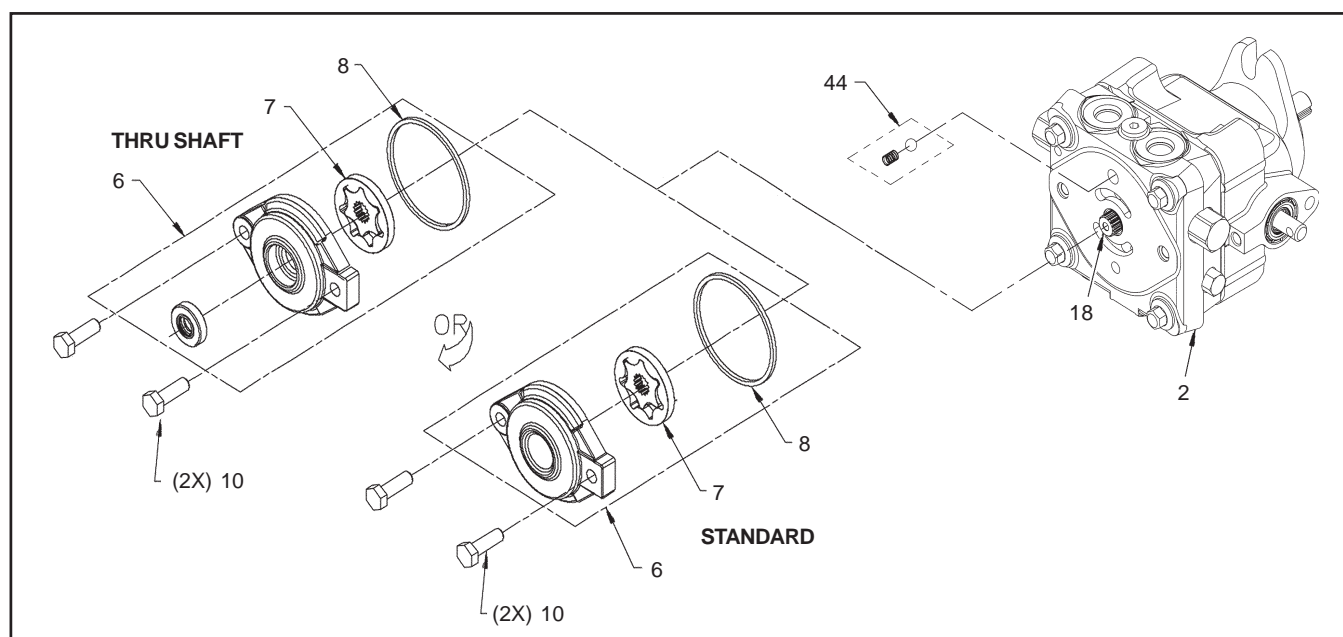

Figure 8. PC Pump Standard or Thru Shaft Charge Pump

REMOVAL, INSPECTION AND/OR REPLACEMENT OF AUXILIARY PUMP (IF EQUIPPED)

Refer to Figure 9.

Disassembly

1. Prior to removal of the auxiliary pump, place a mark on the auxiliary pump (6), charge pump (7) and end cap (2) for alignment at assembly.
2. Use a 10 mm wrench to loosen the auxiliary pump bolts (10) from the end cap (2). While holding the auxiliary pump in place, remove the bolts (10).
3. Remove the auxiliary pump, gasket, O-ring (8) and charge pump (7). While removing the charge pump, be sure to retain the spring and ball (44A) housed in the end cap (2).
4. Remove the plug (66) from the filter cover (67).
5. Use a 7/8 inch wrench to remove the filter cover assembly (67) from the pump.
6. Remove the O-ring and filter (54).
7. Remove the charge relief valve assembly (44) and auxiliary relief valve assembly (45) from the auxiliary pump.

Inspection

1. With the auxiliary pump removed, inspect the pump running surfaces for wear or damage.
2. Inspect all O-rings, gasket and mounting seats.

3. Inspect the filter cover assembly threads and filter for wear, damage or foreign material.

Assembly

1. Install the check ball, spring, and cap as one assembly (45) into the auxiliary relief valve port. Tighten to the correct torque value. See page 22.
2. Install the poppet, spring and cap as one assembly (44) into the charge relief port. Tighten to the correct torque value. See page 22.
3. Install the filter (54) and O-ring into the filter cover assembly (67). Install the assembly (67) into the auxiliary pump and tighten. Install plug (66) into the filter cover (67).
4. Lay the PC pump (input shaft down), so the end cap is horizontal. Install the O-ring (8) into the charge pump (7).
5. Install the gasket onto the auxiliary pump.
6. Make sure that the ball and spring (44A) are seated in the end cap (2), then position the auxiliary pump and gasket with the aligning mark on the charge pump (7). Insure that the pump fully engages the alignment pins (69).
7. Align and insert the bolts (10) into the auxiliary pump. While holding the auxiliary pump and charge pump in place, tighten the bolts (10) per table, page 22.

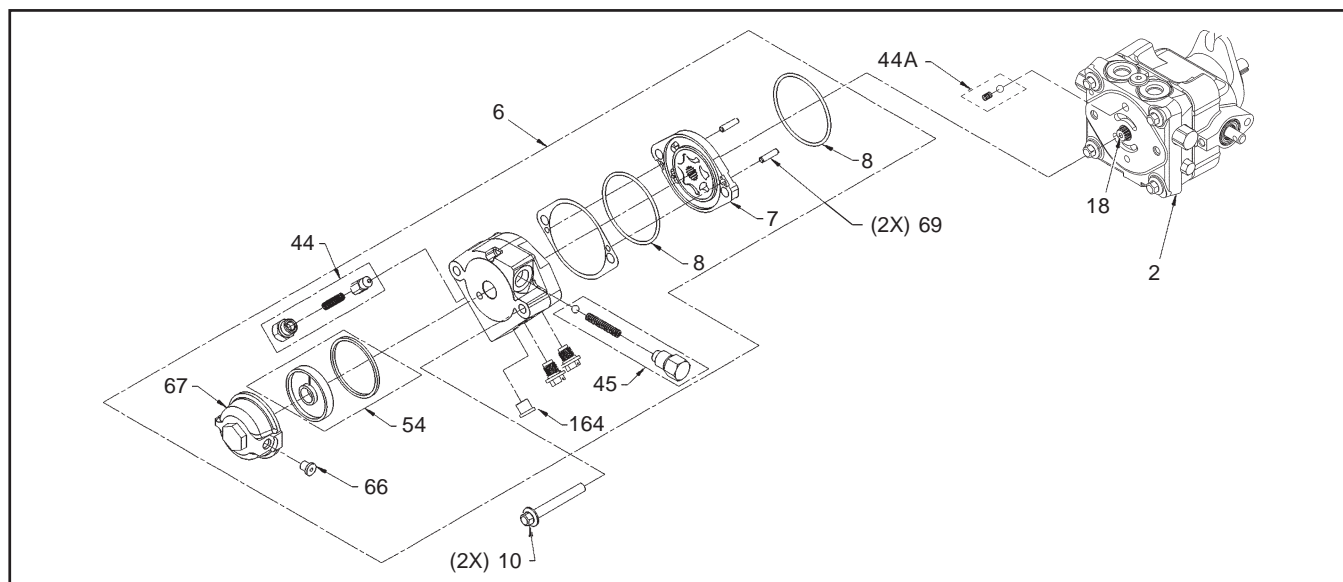

Figure 9. PC Series Auxiliary Pump

REMOVAL, INSPECTION AND ASSEMBLY OF THE END CAP

Refer to Figure 10.

Disassembly

1. Remove charge pump. (See page 27).
2. Using a 10 mm wrench, loosen the end cap bolts (4) evenly.
3. Hold the end cap (2) in place and remove the four end cap bolts (4).
4. Slowly remove the end cap (2).
5. Remove housing gasket (5).

Inspection

1. Inspect the end cap (2) body for damage, nicks or unusual wear patterns. Replace if necessary.
2. Inspect the running surface (side that contacts the cylinder block) (31). The running surface may show evidence of minor abrasive rings, this is normal.

Grooving in the plate, or material transfer that is evident when the surface is checked by dragging a fingernail across it, would be cause for replacement of the end cap (2).

3. Replace the housing gasket (5) with a new gasket before assembly.

Assembly

1. Install housing gasket (5) into housing gasket seat of housing (1).
2. Lubricate the mating surface of the cylinder block (31) to end cap (2) with clean oil prior to installation.
3. Install end cap (2). Before installing the four end cap bolts (4), push down on end cap (2) verifying alignment and insuring that the cylinder block pistons spring back and forth. Install end cap bolts (4). Tighten to the correct torque value. See Table 2, page 22 (Torque Values)
4. Install the charge pump. (See page 27).

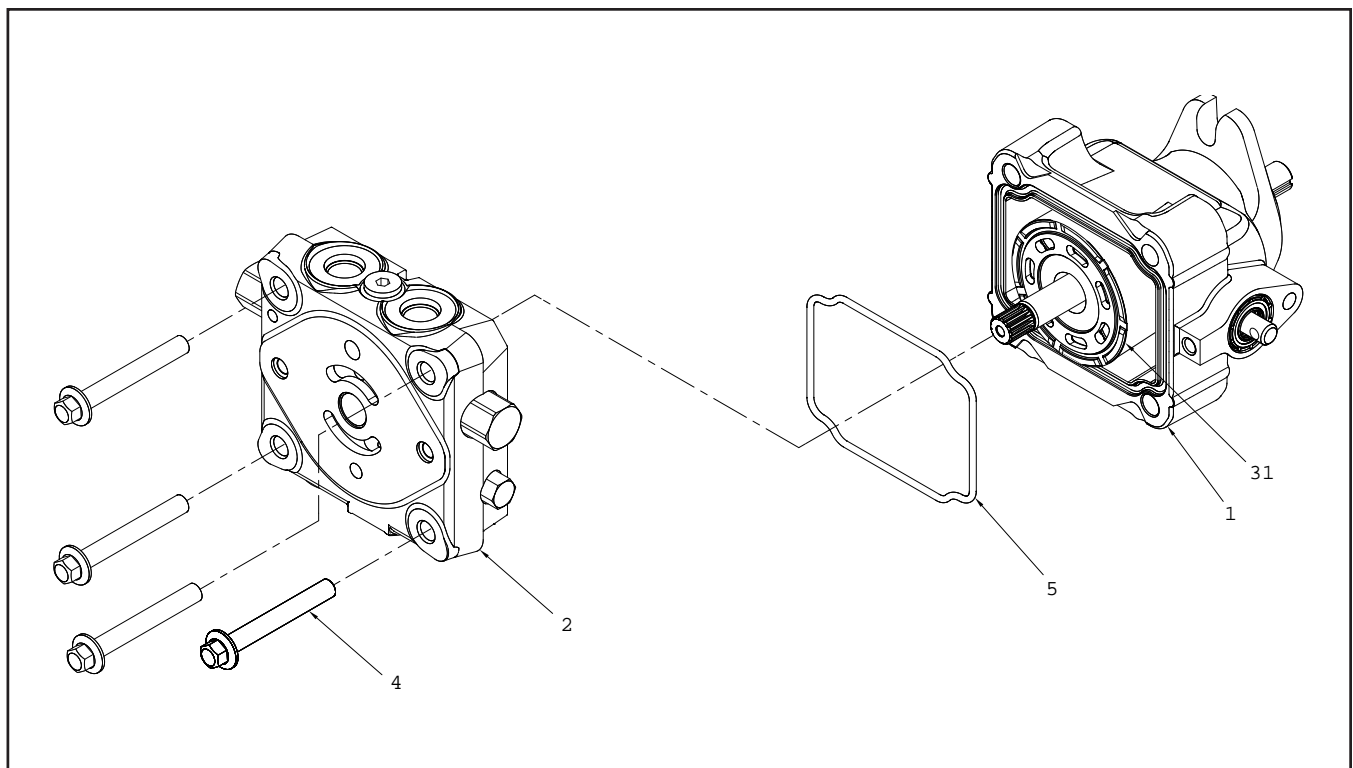

Figure 10. PC Pump End Cap

REMOVAL, INSPECTION AND ASSEMBLY OF THE CYLINDER BLOCK

Refer to Figure 11.

Disassembly

1. Remove charge pump. (See page 27).
2. Remove end cap. (See page 29).
3. Tilt the pump on its side and drain remaining oil. Lift out the cylinder block assembly (25).
4. Remove the pistons, springs and piston seats.

Inspection

1. Inspect the running surface of the cylinder block and piston ends for damage, nicks or unusual wear patterns. The running surface may show evidence of minor abrasion. This will be normal wear. If grooved or smeared, replace with a new cylinder block assembly.
2. Inspect the piston springs for distortion or breaks. If necessary, replace with a new cylinder block kit.
3. Inspect the piston seats. Residual oil may cause these to remain stuck to the inside of the pistons.

Assembly

1. Apply a thin layer of clean oil to the pistons and springs.

2. Install piston seats into the end of the pistons.
3. Install springs into the pistons.
4. Install each piston, spring and seat assembly into the cylinder block.

NOTE: To assist in cylinder block installation, a rubber band can be placed around all of the pistons to hold them in position.

After the cylinder block is installed, cut the rubber band and remove it from the housing.

5. With the pump housing tilted on its side, install the cylinder block assembly (25) with pistons contacting the thrust bearing.

NOTE: To check if the cylinder block assembly is installed correctly, position the pump housing vertically and support the housing at the mounting flange. Push down on the cylinder block. The cylinder block must move up and down freely. If it does not, remove the cylinder block assembly and reinstall.

6. Install the end cap. (See page 29).
7. Install the charge pump. (See page 27).

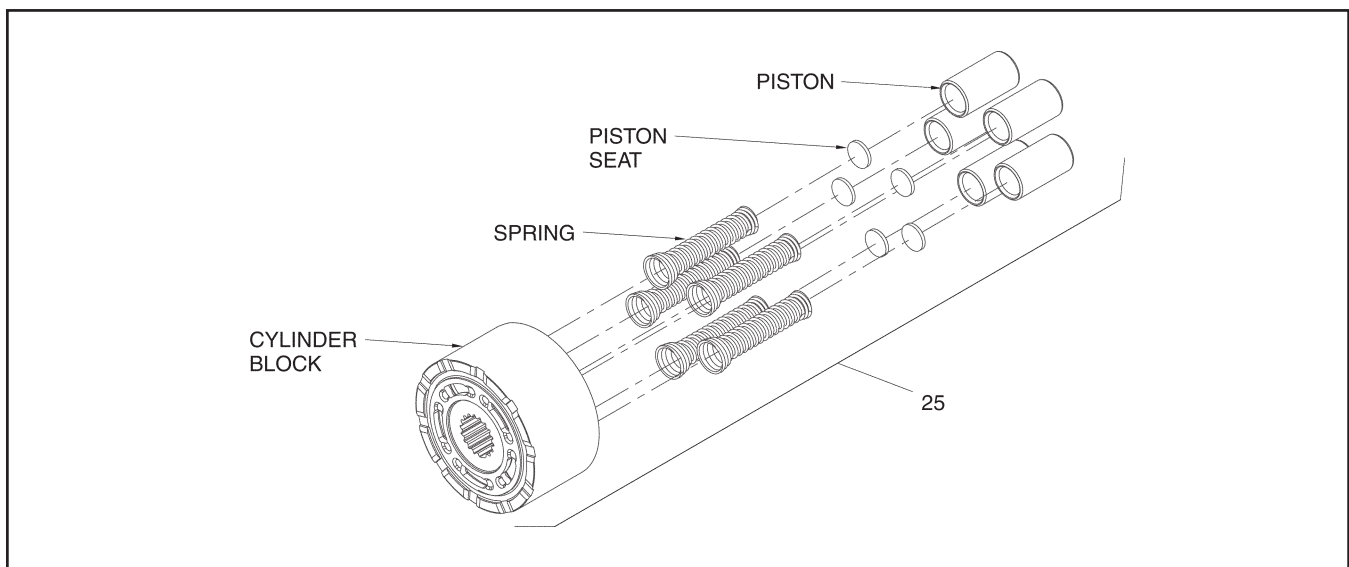

Figure 11. PC Pump Cylinder Block Assembly

REMOVAL, INSPECTION AND ASSEMBLY OF BLOCK SPRING AND THRUST BEARING

Refer to Figure 12.

Disassembly

1. Remove the block spring (29).
2. Remove the thrust bearing and races (34).

Inspection

1. Inspect and replace the block spring (29) if it is distorted or broken.
2. Inspect the running surface of the bearing races for damage, nicks or unusual wear patterns. The running surface may show evidence of minor abrasion. This will be normal wear.

Inspect the bearings for free movement. Inspect the bearing cage for distortion or damage. Replace if necessary.

Assembly

1. Install thrust bearing and race assembly (34).
2. Install block spring (29).

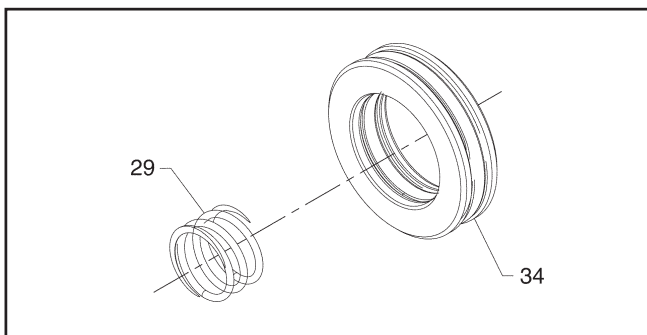

Figure 12. PC Pump Block Spring and Thrust Bearing

REMOVAL, INSPECTION AND ASSEMBLY OF SWASHPLATE AND CRADLE BEARINGS

Refer to Figure 13.

Disassembly

Remove the swashplate (32).

Inspection

1. Inspect the running surface of the bearing pocket of swashplate (32) for damage, nicks or unusual wear patterns. The running surface may show evidence of minor abrasion. This is normal wear. Inspect the cradle bearing side of the swashplate (32) for damage. Replace if necessary.
2. Inspect the cradle bearings attached to the inside of the housing (1) for normal wear patterns and placement, and insure they are staked securely in place. If the bearings are damaged, replace housing (1).

NOTE: The cradle bearings will have discoloration due to normal wear. Under normal circumstances, this will not warrant replacement.

Assembly

1. Install swashplate (32) by holding trunnion arm's slot guide (38) with a flat tip screwdriver. Use the screwdriver to hold the slot guide in place while positioning the swashplate (32) onto the cradle bearing in the housing (1).
2. Rotate trunnion arm (37) to verify that the swashplate moves freely.

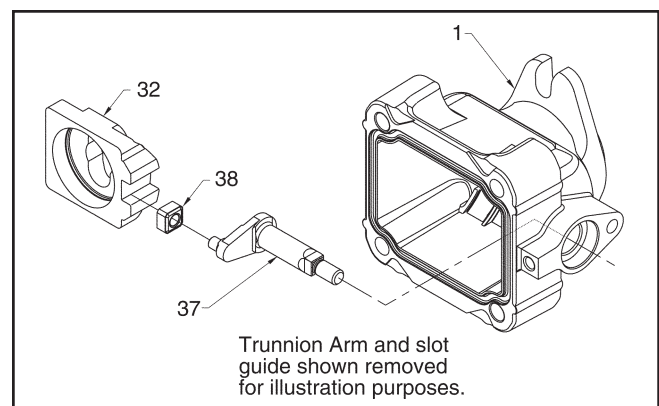

Figure 13. PC Pump Swashplate and Cradle Bearings

REMOVAL, INSPECTION AND ASSEMBLY OF INPUT SHAFT

Refer to Figure 14.

Disassembly

1. Remove the retaining ring (22).
2. Remove the lip seal (20).
3. Remove the spacer (21).
3. Remove the shaft (18) and bearing (19) assembly (18) from the pump.

Inspection

1. Inspect the input shaft (18) for worn splines, surface damage, or keyway damage. Replace shaft assembly if necessary.
2. Inspect the bearing (19) for evidence of scoring, corrosion, or damage. If the bearing must be replaced, remove the retaining ring (23) and use a press or bearing puller to remove the bearing.
3. Inspect and replace the spacer (21) if it is bent or broken.
4. Inspect and replace the retaining ring (22) if it is bent or broken.

NOTE: Upon removal, all seals, O-rings and gaskets should be replaced.

Assembly

NOTE: If trunnion arm is to be removed, do not assemble input shaft until the trunnion arm is installed.

NOTE: During installation, lightly lubricate all seals, O-rings and gaskets with clean petroleum jelly prior to assembly. Also, protect the inner diameter of seals by covering the shaft with plastic wrap.

1. If removed, press bearing (19) onto shaft (18) tight against the shoulder of the shaft. Install retaining ring (23) onto the shaft (18).
2. Install input shaft assembly (18) into the housing (1) bore. Light tapping with a rubber mallet may be necessary on the input shaft (18) once the bearing is aligned with the housing (1) bore. Verify that the shaft rotates smoothly.
3. Install spacer (21).
4. Install new lip seal (20) with the flat side of the seal toward the outside of the pump.
5. Remove the plastic wrap.
6. Install retaining ring (22).

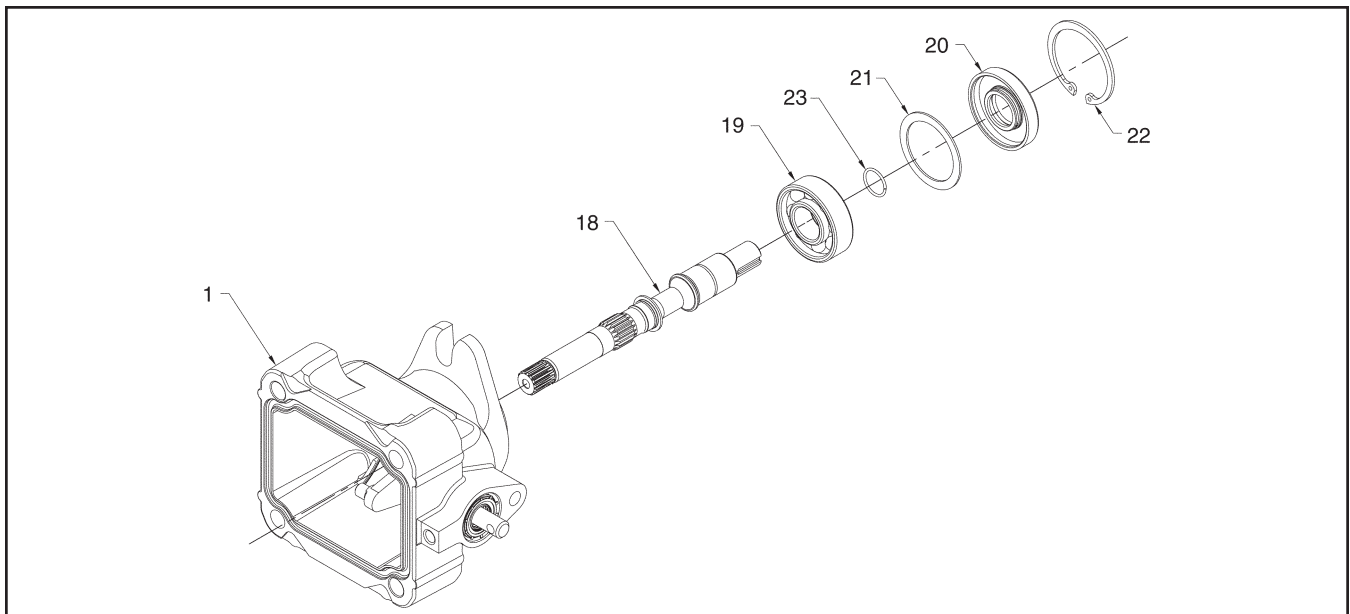

Figure 14. PC Pump Input Shaft

REMOVAL, INSPECTION AND INSTALLATION OF TRUNNION ARM

Refer to Figure 15.

Disassembly

1. Remove the slot guide (38).
2. Remove and discard the trunnion seal retainer and seal (49).
3. Remove the trunnion arm (37).

Inspection

NOTE: Upon removal, all seals, O-rings and gaskets should be replaced.

1. Inspect the trunnion arm (37) for wear or damage. Replace the trunnion arm if necessary.
2. Check for excessive play between trunnion arm (37) and housing (1). Replace housing if necessary.

Assembly

1. Install the trunnion arm (37) into the housing (1) bore. Rotate the trunnion arm to verify free movement.

NOTE: During installation, lightly lubricate all seals, O-rings and gaskets with clean petroleum jelly prior to assembly. Also protect the inner diameter of the seals by covering the shaft with plastic wrap. Remove the plastic wrap after the seal is installed.

2. Install a new seal and seal retainer (49).
3. Install slot guide (38).
4. To completely assemble the pump, refer to the assembly steps on pages 23-33. Begin with the trunnion arm assembly steps listed on page 33 and complete the assembly steps in reverse order working toward the front of the manual.

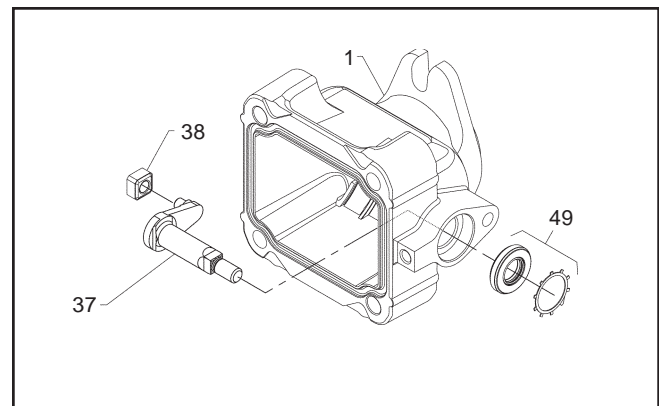
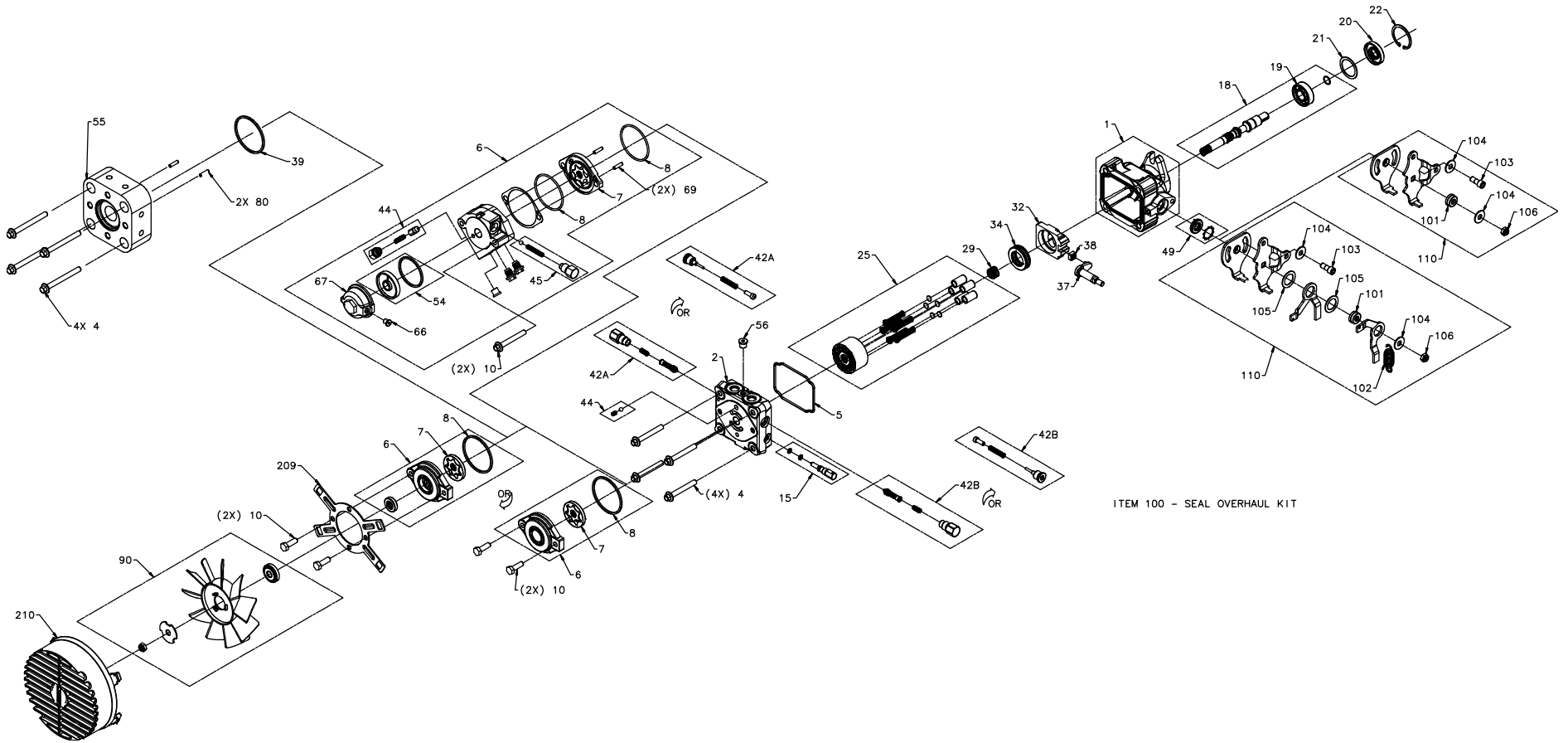

Figure 15. PC Pump Trunnion Arm

Figure 16. PC Pump



BOXES INDICATE ITEMS INCLUDED IN KITS.

Kit Number

ITEM LIST - PC SERIES

Part numbers are not provided in this manual. See CD (BLN-51427) for part numbers.

No.	Description	No.	Description
1	Housing Kit	44	Charge Relief Valve Kit (1/4 in. Plastic Ball and 50654 Spring)
2	End Cap	45	Auxiliary Relief Valve Kit
4	Screw, Hex Flange, M8 x 1.25	49	Trunnion Seal/Retainer Kit
5	Housing O-Ring	54	Filter Kit
6	Charge Pump Kit (Std. Charge)	55	Plate, Adapter (Gear AA)
	Charge Pump Kit (Std. Charge) Thru Shaft	56	Plug, 5/16 - 24
7	STD Gerotor Assy (0.11 cu in./rev)	66	Plug
8	O-Ring	67	Filter Cover
10	Cap Screw, Hex, 5/16 - 18 x 1.0	69	Pin, Straight Headless
15	Bypass Valve Kit (No Bleed Orifice)	80	Pin, Straight Headless
18	Pump Shaft Kit (1/2 in. Keyed w/Std. Charge)	90	Fan Kit
	Pump Shaft Kit (1/2 in. Keyed, Thru Shaft w Std. Charge)	100	Overhaul Seal Kit
	Pump Shaft Kit (9 tooth w/Std. Charge)	101	Spacer, Return
19	Ball Bearing, 17 x 40 x 12 mm	102	Spring, Extension
20	Lip Seal, 17 x 40 x 7 PTC	103	Screw, 5/16 x 0.875 in. (PATCH)
21	Spacer	104	Washer, 0.34 x 0.88 x 0.06 in.
22	Retaining Ring	105	Washer, Nylon
23	Retaining Ring	106	Nut, Hex Lock, 5/16 - 24 UNF
25	Cylinder Block Kit	110	Return-to-Neutral Kit, Std.
29	Block Spring		Return-to-Neutral Kit, CW Scissor
32	Swashplate		Return-to-Neutral Kit, CCC Scissor
34	Ball Thrust Bearing		Return-to-Neutral Kit,
37	Trunnion Arm, Tapered Square Trunnion Arm, Double D	209	Shroud Bracket
38	Slot Guide	210	Shroud
42	Shock Valve Kit		
	2900 psi, (200 bar), No Orifice		
	2900 psi, (200 bar), 0.024 in. Orifice		
	2900 psi, (200 bar), 0.031 in. Orifice		
	2900 psi, (200 bar), 0.044 in. Orifice		
	2320 psi, (160 bar), No Orifice		
	2320 psi, (160 bar), 0.024 in. Orifice		
	2320 psi, (160 bar), 0.031 in. Orifice		
	2320 psi, (160 bar), 0.044 in. Orifice		
	1740 psi, (120 bar), No Orifice		
	1740 psi, (120 bar), 0.024 in. Orifice		
	1740 psi, (120 bar), 0.031 in. Orifice		
	1740 psi, (120 bar), 0.044 in. Orifice		

REPAIR - PG AND PE SERIES PUMP

Repair - PG and PE Series Pump	37-54
How to Use This Manual.....	37
General Instructions	37
Tools and Torques	38
Return to Neutral Linkage.....	39
Standard Control Arm Linkage	40
Fan Assembly	40
Input Shaft Seal	41
Trunnion Arm Seal	41
Check Valves	42
Shock Valves	42
Bypass.....	43
Charge Pump-Standard or Thru Shaft.....	44
Auxiliary Pump.....	45
End Cap.....	46
Cylinder Block.....	47
Block Spring and Thrust Bearings	48
Swashplate and Cradle Bearings	48
Input Shaft	49
Trunnion Arm	50
Parts List.....	52-53

HOW TO USE THIS MANUAL

Each assembly is provided with an exploded view showing the parts involved. **The item reference numbers in each illustration are for assembly instructions only.** See pages 52 and 53 for part names and descriptions. A complete exploded view and item list of the pump is provided at the end of this section.

GENERAL INSTRUCTIONS

Cleanliness is a primary means of ensuring satisfactory life on repaired pumps. Thoroughly clean all exposed surfaces prior to any type of maintenance. Cleaning of all parts by using a solvent wash and air drying is usually adequate. As with any precision equipment, all parts must be kept free of foreign material and chemicals.

Protect all exposed sealing surfaces and open cavities from damage and foreign material. The external surfaces should be cleaned before beginning any repairs.

Lip-type seals (shaft seals) are used on the input shaft and directional control shaft of each pump. These seals can be replaced without major disassembly of the unit. However, replacement of these seals generally requires removal of the pump from the machine. Upon removal, it is recommended that all seals, O-rings and gaskets be replaced.

During installation, lightly lubricate all seals, O-rings and gaskets with clean petroleum jelly prior to assembly. Also protect the inner diameter of the seals by covering the shaft with a cellophane (plastic wrap, etc.) material.

Parts requiring replacement must be replaced from the appropriate kits identified in the Items Listing, found at the end of this manual. Use only original Hydro-Gear replacement parts found listed in BLN-51427 (CD).

TOOLS AND TORQUES

Miscellaneous	3/8-Inch Drive Ratchet and Sockets
P Series Service & Repair Manual	1/2-inch Socket
Torque Wrench	9/16-inch Socket
Scribe, Paint Pen, or Marker	5/8-inch Socket
Seal Hook with a Magnet	10-mm Socket
Flat Blade Screwdriver	
	Combination Wrenches
Pliers	1/2 inch
Internal Snap Ring	9/16 inch
	5/8 inch
Allen Wrenches	7/8 inch
5mm	10 mm
3/16 inch	
1/4 inch	

Table 1. Required Tools

Item # and/or Description	Torque
Case Drain (fitting torque)	200-250 lb-in (22.6-28.2 Nm)
System Port (fitting torque)	370-470 lb-in (41.8-53.1 Nm)
Inlet (fitting torque)	200-250 lb-in (22.6-28.2 Nm)
Fan Nut, Hex Lock 5/16-24 UNF	180-220 lb-in (20.3-24.9 Nm)
4, End Cap Bolts	180-220 lb-in (20.3-24.9 Nm)
10, Cap Screw (Aux Pump and Shroud Bracket)	180-220 lb-in (20.3-24.9 Nm)
10, Cap Screw (Charge Pump Cover)	87-118 lb-in (9.8-13.3 Nm)
15, Bypass Valve	110-130 lb-in (12.4-14.7 Nm)
42A, 42B, Shock Valves/Check Plugs	180-240 lb-in (20.3-27.1 Nm)
44, System Charge Relief Kit (Aux Chg)	180-240 lb-in (20.3-27.1 Nm)
45, Aux Relief Valve Kit	180-240 lb-in (20.3-27.1 Nm)
56, Diagnostic Plug	84-120 lb-in (9.4-13.5 Nm)
66, Filter Cover Plug	55-85 lb-in (6.2-9.6 Nm)
67, Filter Cover	200-275 lb-in (22.6-31.1 Nm)
95, Screw, Socket Head Set	100-185 lb-in (11.3-20.9 Nm)
103, Screw 5/16 x .875	200-240 lb-in (22.6-27.1 Nm)
106, Bolt	180-220 lb-in (20.3-24.9 Nm)
107, Nut, Hex Lock 5/16-24UNF	180-220 lb-in (20.3-24.9 Nm)

Table 2. PG / PE Pump Torque Values

PG AND PE SERIES PUMP REPAIR

REMOVAL, INSPECTION AND/OR REPLACEMENT OF RETURN TO NEUTRAL ASSEMBLY

Refer to Figure 1.

Prior to disassembly, note the position of the scissor arm brackets and the tab on the outer control arm bracket.

Disassembly

CAUTION: The spring used on the return to neutral linkage is under tension. To avoid possible injury, use care and proper protection during disassembly and assembly of the return to neutral linkage.

1. Loosen (but do not remove) the bolt (106)/nut(107).
2. To relieve spring tension, carefully pry up on the outer scissor control arm until it releases from the tab on the outer control arm bracket.
3. Remove the spring (102), bolt (106)/nut (107) and washer (104).
4. Remove the scissor arm (99).
5. Remove the outer control arm bracket(94), bolt (103), washer (104) and the inner return arm bracket(98).

Inspection

1. With the arm control linkage removed, inspect the trunnion arm (37) and trunnion arm seal (49).
2. Inspect scissor arm (99) and all other linkage parts for damage, corrosion or wear.

Assembly

1. Install the inner return arm bracket(98), washer (104) and bolt (103).

NOTE: Do not over tighten the bolt (103). The bracket must move freely.

2. Install the inner scissor control arm(94)
3. Tighten washer (104), and nut (103) to the correct torque value. See page 38.
4. Install the scissor arm(99).
5. Install washer(104) and bolt (106)/nut(107) to the correct torque value. See page 38.
5. Install the spring (102).

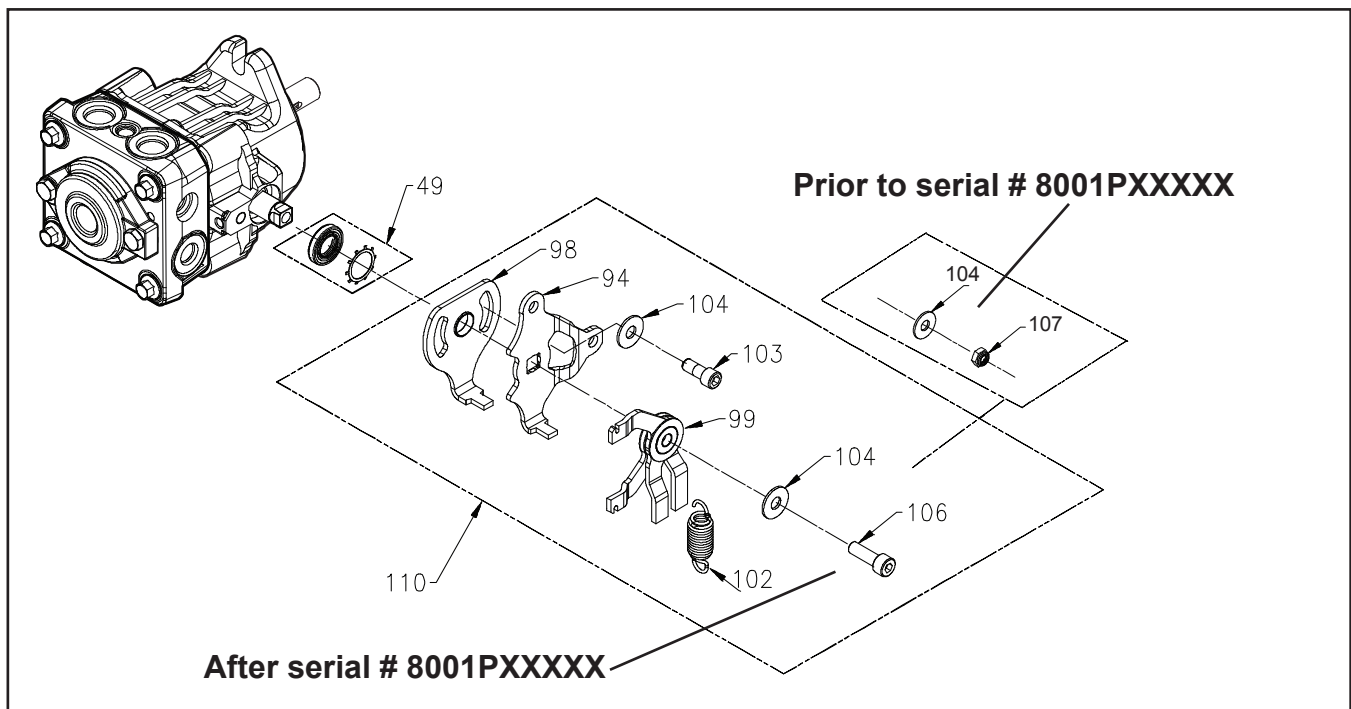

Figure 1. PG / PE Pump Return to Neutral

REMOVAL, INSPECTION AND/OR REPLACEMENT OF CONTROL ARM

Refer to Figure 2.

Disassembly

1. Remove the bolt (106), washer (104) and bushing (101).
2. Remove the outer control arm bracket.
3. Remove bolt (103), washer (104) and the inner control arm bracket.

Inspection

1. With the arm control linkage removed, inspect the trunnion arm (37) and trunnion arm seal (49).
2. Inspect bushing (101) and all other linkage parts for damage, corrosion or wear.

Assembly

1. Install the inner control arm bracket, washer (104) and bolt (103).

NOTE: Do not over tighten the bolt (103). The bracket must move freely.

2. Install the outer control arm bracket, bushing (101), washer (104), and bolt (106). Tighten to the correct torque value. See page 38.

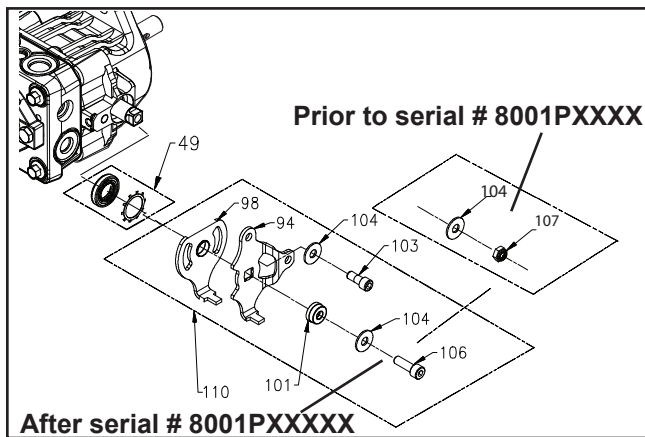

Figure 2. PG / PE Pump Standard Control Arm

REMOVAL, INSPECTION AND/OR REPLACEMENT OF FAN ASSEMBLY

Refer to Figure 3.

Disassembly

1. Remove the fan shroud (210) from the mounting bracket (209) by carefully pushing down on the shroud tabs.
2. Remove the nut (106) and fan assembly (90).
3. Remove the bolts (10) and bracket (209).

Inspection

Inspect the fan shroud (210), fan assembly (90) and mounting bracket (209) for damage.

Assembly

1. To install the mounting bracket (209), align and insert the bolts (10) into the bracket and charge pump cover. While holding the charge cover in place, tighten the bolts (10) per table 2, page 38.
2. Install the fan and washer assembly onto the shaft.
3. Install the nut (106) and tighten per table 2, page 38.
4. Install the fan shroud (210) onto the mounting bracket (209). Make sure that all shroud lock tabs are fully engaged in the mounting bracket slots.

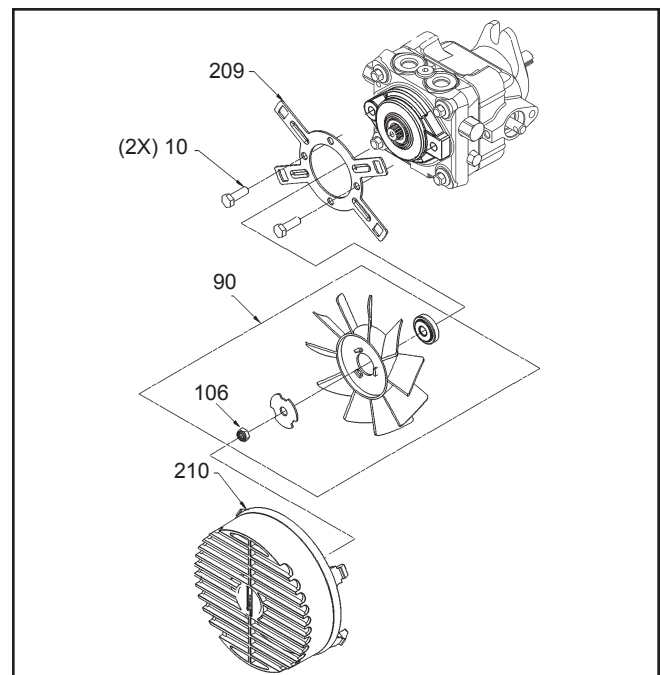

Figure 3. PG / PE Pump Fan Assembly

REMOVAL, INSPECTION AND/OR REPLACEMENT OF INPUT SHAFT SEAL

Refer to Figure 4.

Disassembly

1. Remove retaining ring (22) from housing.
2. Remove lip seal (20). Care must be taken to prevent damage to the housing bore, shaft sealing surface, or bearing. Once removed, the seal is not reusable.

Inspection

1. With seal removed inspect the spacer (21), input shaft bearing (19) and housing (1) bore for damage, corrosion or wear.

Assembly

1. Lubricate the new lip seal (20) inside diameter with petroleum jelly.
2. Wrap the input shaft (18) with plastic wrap to prevent damage to the inner surface of the lip seal (20).
3. Slide seal (20) over shaft (18) so that lettering on the seal faces out.
4. Press the lip seal (20) into the housing bore. Insure the lip seal (20), shaft (18) or housing (1) bore do not become damaged. Remove plastic wrap.
5. Install the retaining ring (22) into the housing (1) bore groove.

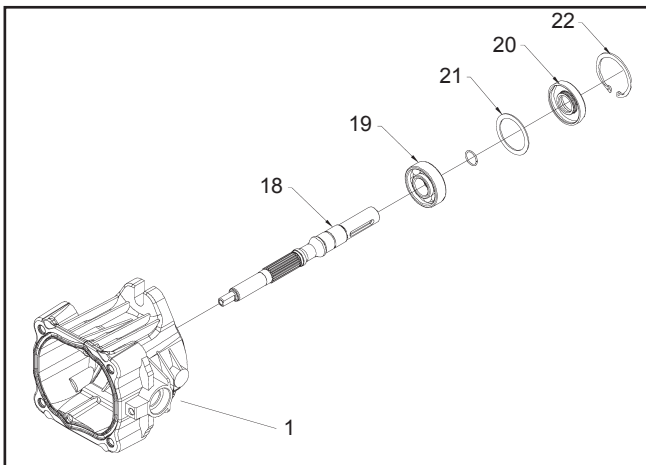

Figure 4. PG / PE Pump Input Shaft Seal

REMOVAL, INSPECTION AND/OR REPLACEMENT OF TRUNNION ARM (CONTROL ARM) SEAL

Refer to Figure 5.

Disassembly

1. Remove the retainer and lip seal (49) from the housing (1). Care must be taken to prevent damage to the housing trunnion bore, trunnion arm (37) and sealing surface. Once removed the retainer and lip seal is not reusable.

Inspection

1. With the lip seal (49) removed, inspect the area for corrosion and wear. Inspect the trunnion bore area sealing surface for damage or wear.

Assembly

1. Lubricate the new lip seal (49) with petroleum jelly.
2. Wrap the trunnion arm (37) with plastic wrap to prevent damage to the inner surface of the lip seal (49).
3. Slide the lip seal (49) over the trunnion arm (37) so that the lettering on the seal (49) faces out.
4. Press the lip seal (49) into the housing bore (1). Insure the seal (49), trunnion arm (37), and housing bore do not become damaged. Remove the plastic wrap.
5. Install the retainer from (49) over the trunnion arm (37) on top of the lip seal (49). Press into the trunnion seal bore in the housing until the retainer mates against the trunnion seal.

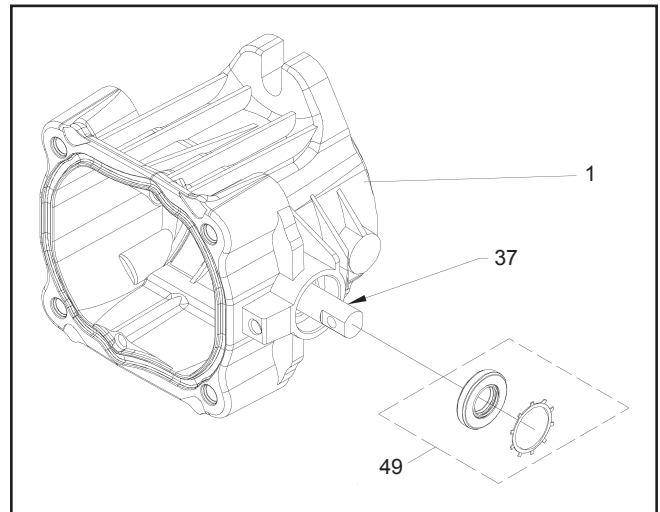

Figure 5. PG / PE Pump Trunnion Arm Seal

REMOVAL, INSPECTION AND/OR REPLACEMENT OF CHECK VALVES

Refer to Figure 6.

Disassembly

Perform disassembly, inspection and assembly on check valves one side at a time. Some units vary in “A” side to “B” side check configuration.

1. Remove the check valve (42) with an 1/4” allen wrench.
2. Remove the valve spring and poppet from the end cap (2).

Inspection

1. Inspect the poppets and mating seats in the end cap (2) for damage or foreign material.

Assembly

1. Lay the pump on its side, so the check plug port is horizontal.
2. Insert the check plug, spring and poppet (42) as one assembly into the check plug port. Tighten, reference Table 2, page 38 for torque values.
3. Repeat disassembly, inspection and assembly for the opposite port side.

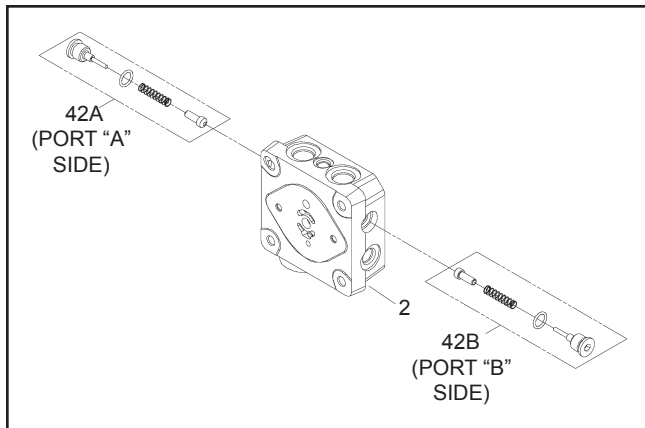

Figure 6. PG / PE Pump Check Valves

REMOVAL, INSPECTION AND/OR REPLACEMENT OF SYSTEM CHECK RELIEFS (SCR'S) OR SHOCK VALVES

Refer to Figure 7.

Disassembly

Perform disassembly, inspection and assembly on SCR/shock valve one side at a time. Some units vary in “A” side to “B” side configuration.

1. Remove the SCR (42) with a 7/8” wrench or the shock valve (42) with an 11/16” wrench.
2. Remove the check relief/shock valve spring and the check relief/shock valve from the end cap (2).

Inspection

1. Inspect the check relief or shock valve (42) and mating seat in the end cap (2) for damage or foreign material.

Assembly

1. Lay the pump on its side, so the check plug port is horizontal.
2. Insert the system check relief spring and check relief or shock valve spring and shock valve as one assembly into the check plug port. Tighten to the correct torque value. See page 38.
3. Repeat disassembly, inspection and assembly for the opposite port side.

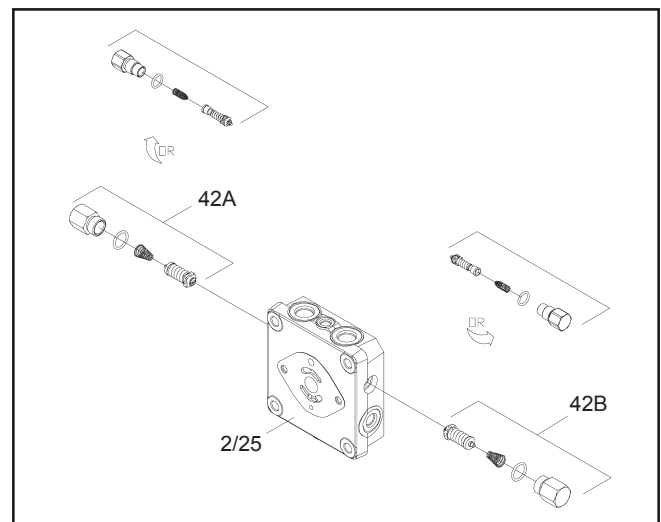

Figure 7. PG / PE Pump Shock Valves

REMOVAL, INSPECTION AND /OR REPLACEMENT OF THE BYPASS

Refer to Figure 8.

Disassembly

1. Loosen the bypass valve (15) using a 5/8" wrench.
2. Remove the bypass (15) from the end cap (2).

Inspection

1. Inspect the bypass O-rings and mating seats in the end cap (2) for damage or foreign materials.
2. If damaged or worn replace bypass (15)

Assembly

1. Lay the pump on its side, so the bypass port is horizontal.
2. Insert the bypass (15) into the bypass port on the end cap (2). Tighten to the proper torque value. See page 38.

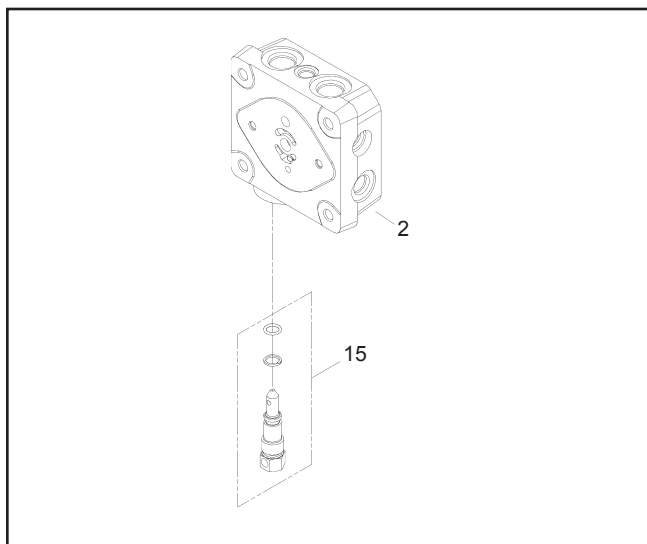

Figure 8. PG / PE Pump Bypass

REMOVAL, INSPECTION AND ASSEMBLY OF STANDARD OR THRU SHAFT CHARGE PUMP

Refer to Figure 9.

Disassembly

1. Prior to removal of the charge pump cover, place a mark on the cover and end cap for alignment at assembly.
2. Using a 1/2 inch wrench, or 5 mm allen wrench, loosen the charge pump cover bolts (10) from the end cap (2). While holding the charge cover in place, remove the charge cover bolts (10).
3. Remove the charge cover, O-ring and gerotor items (6). Carefully check for and remove the charge spring and charge ball (44).
4. For the Thru Shaft charge pump, remove the shaft seal.

Inspection

1. Inspect the charge cover O-ring and running surfaces for damage. Inspect the spring, check ball (44), and mating seat in the end cap (2) for damage or foreign material.

NOTE: If the end cap (2) is to be removed from the housing, do not assemble the charge pump (6) until the end cap is installed on the housing.

2. Inspect the charge cover bore for damage, corrosion or wear.

Assembly

NOTE: For the Thru Shaft charge pump follow steps 1-8. For the Standard charge pump follow steps 3-8.

1. Lubricate the new shaft seal with petroleum jelly.
2. Press the shaft seal into the charge cover. Be careful not to damage the seal or charge cover bore.
3. Position the pump with the input shaft down, and the end cap (2) horizontal. Place the charge ball (44) in the end cap (2) charge passage so the ball mates to the end cap (2) charge ball seat. Place the charge spring, on top of the charge ball.
4. Insert the inner gerotor over input shaft (18).
5. Align the outer gerotor to fit over the inner gerotor.
6. Insert the O-ring into the groove in the charge cover.
7. Position the charge cover and O-ring with the aligning mark on the end cap. Place the charge cover and O-ring with aligning mark on the end cap. Place the charge cover and O-ring as one piece over the charge spring and gerotor assembly. Insure the spring fits into the charge cover spring retaining groove.
8. Align and insert the charge pump cover bolts (10) into the end cap (2). Tighten to the correct torque value. See Table 2, page 38. (Torque Values.)

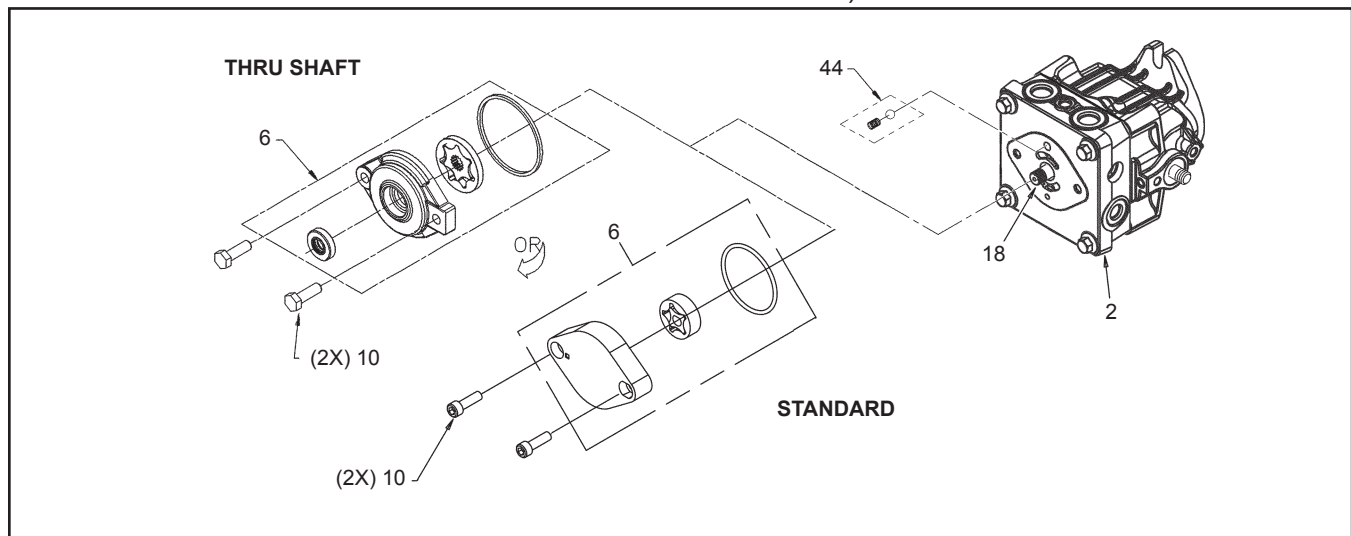

Figure 9. PG / PE Pump Standard or Thru Shaft Charge Pump

REMOVAL, INSPECTION AND/OR REPLACEMENT OF AUXILIARY PUMP (IF EQUIPPED)

Refer to Figure 10.

Disassembly

1. Prior to removal of the auxiliary pump, place a mark on the auxiliary pump, charge pump (7) and end cap (2) for alignment at assembly.
2. Use a 10mm wrench to loosen the auxiliary pump bolts (10) from the end cap (2). While holding the auxiliary pump in place, remove the bolts (10).
3. Remove the auxiliary pump, gasket (75), O-ring (59) and charge pump (7). While removing the charge pump, be sure to retain the spring and ball (44A) housed in the end cap (2).
4. Remove the plug (66) from the filter cover (67).
5. Use a 7/8 inch wrench to remove the filter cover assembly (67) from the auxiliary pump.
6. Remove the O-ring and filter (54).
7. Remove the charge relief valve assembly (44), plug (56) and auxiliary relief valve assembly (45) from the auxiliary pump.

Inspection

1. With the auxiliary pump removed, inspect the pump running surfaces for wear or damage.
2. Inspect all O-rings, gasket and mounting seats.

3. Inspect the filter cover assembly threads and filter for wear, damage or foreign material.

Assembly

1. Install the check ball, spring, and cap as one assembly (45) into the auxiliary relief valve port. Tighten to the correct torque value. See page 38.
2. Install the plug (56). Tighten to the correct torque value. See page 38.
3. Install the poppet, spring and cap as one assembly into the charge relief port. Tighten to the correct torque value. See page 42.
4. Install the filter (54) and O-ring onto the filter cover assembly (67). Install the assembly (67) into the auxiliary pump and tighten. Install plug (66) into the filter cover (67).
5. Lay the PG pump (input shaft down), so the end cap is horizontal. Install the O-ring (59) into the charge pump (7).
6. Install the gasket (75) onto the auxiliary pump.
7. Make sure that the ball and spring (44A) are seated in the end cap (2), then position the auxiliary pump and gasket with the aligning mark on the charge pump (7). Insure that the pump fully engages the alignment pins (69).
8. Align and insert the bolts (10) into the auxiliary pump. While holding the auxiliary pump and charge pump in place, tighten the bolts (10) per table 2, page 38.

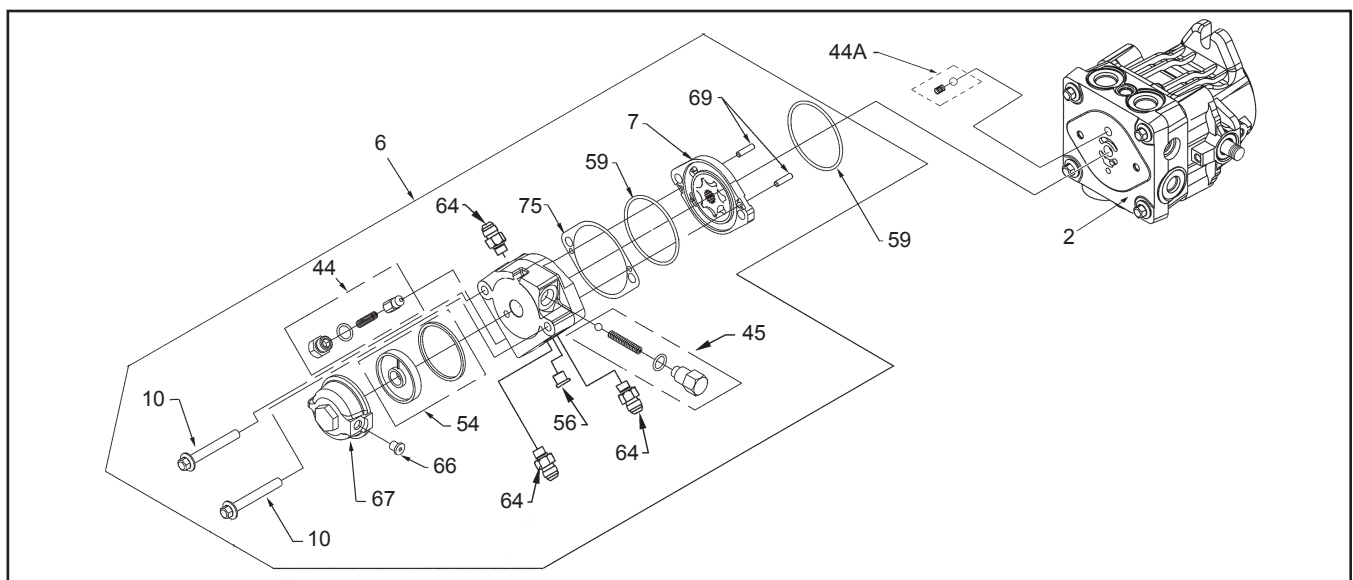

Figure 10. PG / PE Series Auxiliary Pump

REMOVAL, INSPECTION AND ASSEMBLY OF THE END CAP AND VALVE PLATE

Refer to Figure 11a and 11b.

Disassembly

1. Using a 10 mm wrench, loosen the end cap bolts (4) evenly.
2. Keeping the end cap (2) held in place, remove the four end cap bolts (4).
3. Slowly remove the end cap (2).
4. Remove the valve plate (31).

NOTE: Not applicable in PE-series pumps.

5. Remove housing alignment pins (3).
6. Remove housing gasket (5).

Inspection

1. Inspect the end cap body (2) for damage, nicks or unusual wear patterns. Replace if necessary.
2. Inspect the running surface (side that contacts the cylinder block) of the valve plate (31). The running surface may show evidence of minor abrasive rings, this is normal.

NOTE: Grooving in the valve plate and or end cap, made evident when the surface is checked by dragging a fingernail across it, would be cause for replacement of the valve plate.

3. Inspect and replace alignment pins (3) if bent or distorted.
4. Replace the housing gasket (5) with a new gasket before reassembly.

Assembly

1. Install housing gasket (5) into housing gasket seat of housing (1).
2. Install alignment pins (3) into housing (1).
3. Lubricate the valve plate prior to installation. Install valve plate (31) so the stamped letters "UP" on the valve plate are facing up toward the end cap.

NOTE: Not applicable in PE-series pumps.

4. Lubricate the end cap (2) face prior to installation in PE-series pumps.
5. Install end cap (2). Before installing the four end cap bolts (4), push down on the end cap (2) verifying alignment and insuring that the cylinder block pistons spring back and forth. Install end cap bolts (4). Tighten, reference Table 2, page 38 torque values.

PG Series Pumps (With Valve Plate)

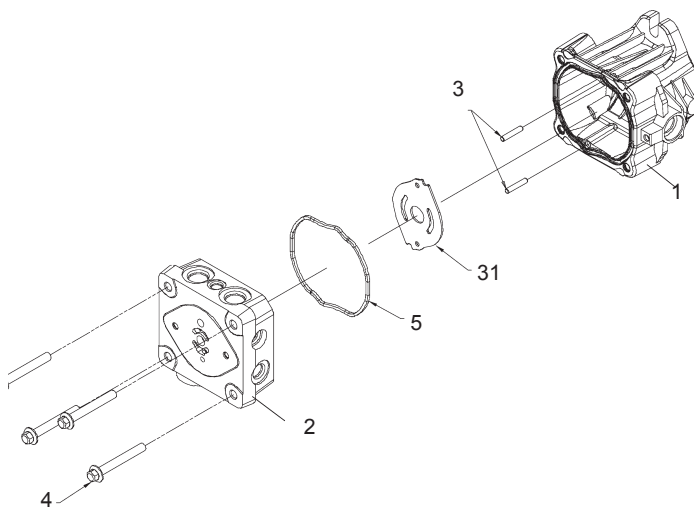

Figure 11a. PG Pump End Cap

PE Series Pumps (No Valve Plate)

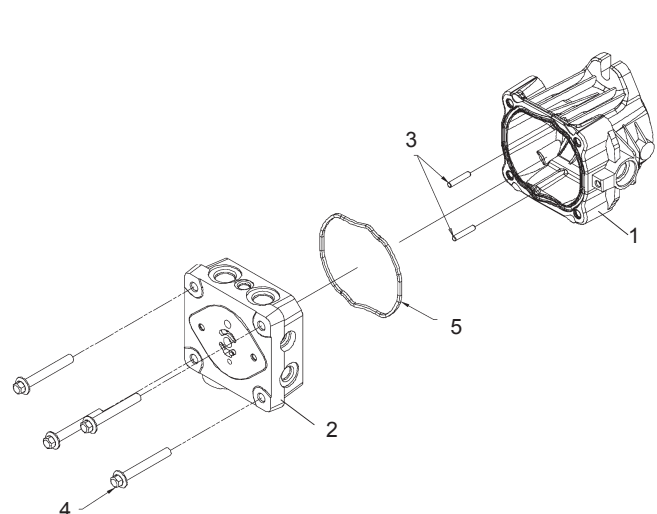

Figure 11b. PE Pump End Cap

REMOVAL, INSPECTION AND ASSEMBLY OF THE CYLINDER BLOCK

Refer to Figure 12.

Disassembly

1. Tilt the pump on its side, drain remaining oil. Lift out the cylinder block assembly (25).
2. Remove the pistons, springs and piston seats.

Inspection

1. Inspect the running surface of the cylinder block and piston ends for damage, nicks or unusual wear patterns. The running surface may show evidence of minor abrasion. This will be normal wear. If grooved or smeared, replace with a new cylinder block assembly.
2. Inspect the piston springs for distortion or breaks. If necessary, replace with a new cylinder block kit.
3. Inspect the piston seats. Residual oil may cause these to remain stuck to the inside of the pistons.

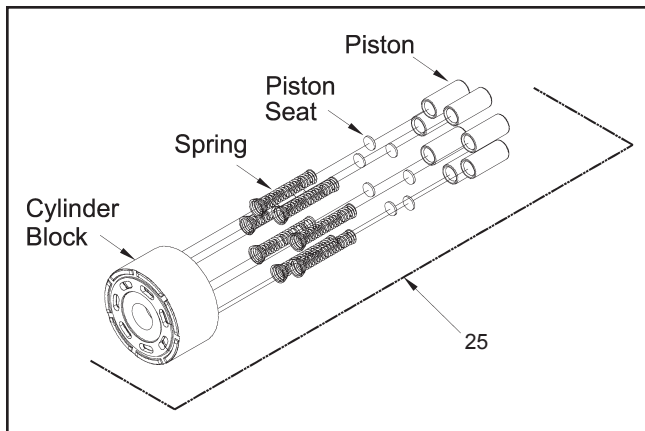

Figure 12. PG / PE Pump Cylinder Block

Assembly

1. Install piston seats into the end of the pistons.
2. Install springs into the pistons.
3. Install one at a time, pistons, springs and seats as one assembly into the cylinder block.
4. With the pump housing tilted on its side, install the cylinder block assembly (25) with pistons contacting the thrust bearing.

NOTE: To check that piston placement is correct, push downward on the cylinder block assembly (25). If this results in a spring action the block assembly has been installed correctly. If this cannot be accomplished, remove and reassemble the block assembly. Place a rubber band around the cylinder block pistons to hold them in position during installation. Then after installation cut the rubber band and remove it. Check cylinder block assembly for spring action.

REMOVAL, INSPECTION AND ASSEMBLY OF BLOCK SPRING, THRUST WASHER, AND THRUST BEARING

Refer to Figure 13.

Disassembly

1. Remove the block spring (29).
2. Remove the block thrust washer (30).
3. Remove the thrust bearing and race (34).

Inspection

1. Inspect and replace the block spring (29) and thrust washer (30) if they are distorted or broken.
2. Inspect the running surface of the bearing race for damage, nicks or unusual wear patterns. The running surface may show evidence of minor abrasion. This will be normal wear.

Inspect the bearings for free movement. Inspect the bearing cage for distortion or damage. Replace if necessary.

Assembly

1. Install thrust bearing and race assembly (34).

NOTE: The difference in race thicknesses: The thin race seats into the swashplate (32). The thicker race will be installed toward the piston noses.

2. Install thrust washer (30).
3. Install block spring (29).

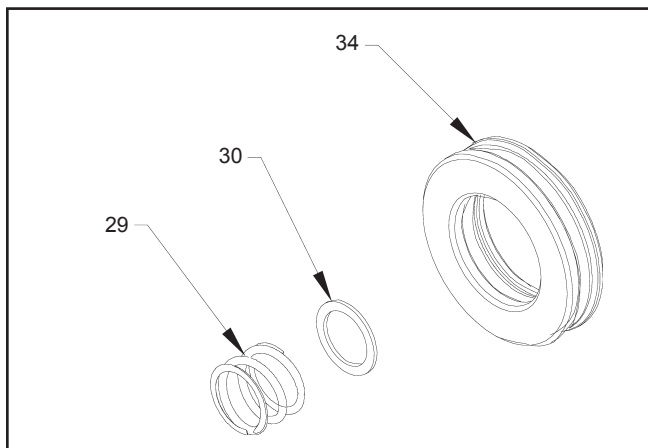

Figure 13. PG / PE Pump Block Spring and Thrust Bearing

REMOVAL, INSPECTION OF SWASHPLATE, INSPECTION OF CRADLE BEARINGS

Refer to Figure 14.

Disassembly

1. Remove the swashplate (32).

Inspection

1. Inspect the running surface of the bearing pocket for damage (32), nicks or unusual wear patterns. The running surface may show evidence of minor abrasion. This is normal wear. Inspect the cradle bearing side of the swashplate (32) for damage. Replace if necessary.
2. Inspect the cradle bearings attached to the inside of the housing (1) for normal wear patterns, placement, and insure they are staked securely in place. If damaged, replace housing (1).

NOTE: The cradle bearings will have discoloration due to normal wear. Under normal circumstances, this will not warrant replacement.

Assembly

1. Install swashplate (32) by holding trunnion arm's (37) slot guide (38) with the aide of a flat tip screwdriver. Use the screwdriver to hold the slot guide (38) in place while positioning the swashplate (32) onto the cradle bearing in the housing (1).
2. Rotate trunnion arm (37) to assure swashplate pivoting action.

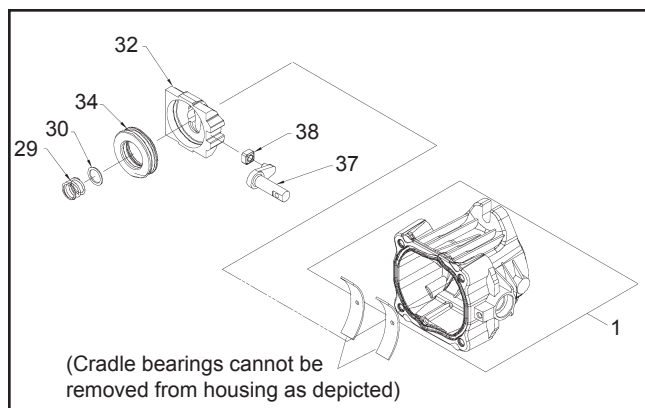

Figure 14. PG / PE Pump Swashplate and Cradle Bearings

REMOVAL, INSPECTION AND ASSEMBLY OF INPUT SHAFT

Refer to Figure 15.

Disassembly

1. Remove the retaining ring (22).
2. Remove the lip seal (20).
3. Remove the spacer (21).
4. Remove the shaft (18) from the pump.

Inspection

1. Inspect the input shaft (18) for worn splines, surface damage, or keyway damage. Replace shaft assembly if necessary.
2. Inspect the bearing (19) for evidence of scoring, corrosion, or damage. Replace shaft assembly if necessary.
3. Inspect and replace the spacer (21) if it is bent or broken.
4. Inspect and replace the retaining ring (22) if it is bent or broken.

NOTE: Replace the input shaft seal (20) after removal.

NOTE: If trunnion arm is to be removed, delay reassembly of input shaft assembly.

Assembly

NOTE: Upon removal, it is recommended that all seals, O-rings and gaskets be replaced. During installation, lightly lubricate all seals, O-rings and gaskets with clean petroleum jelly prior to assembly. Also, protect the inner diameter of seals by covering the shaft with plastic wrap.

1. Install input shaft assembly (18, 19, 23) into the housing (1) bore. Light tapping with a rubber mallet may be necessary on the input shaft (18) once the bearing is aligned with the housing (1) bore. Rotate the input shaft (18) to insure free movement.
2. Install spacer (21).
3. Install new lip seal (20).
4. Remove the plastic wrap.
5. Install retaining ring (22).

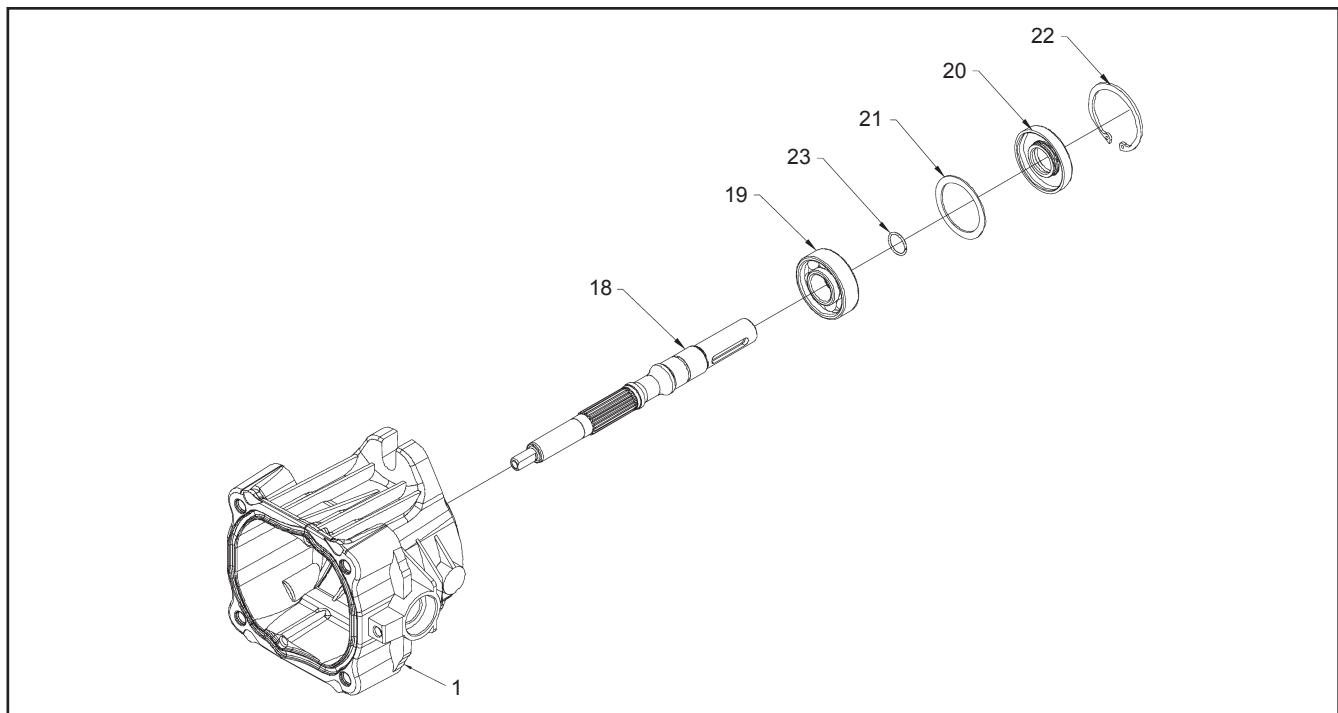

Figure 15. PG / PE Pump Input Shaft

REMOVAL AND INSPECTION OF TRUNNION ARM

Refer to Figure 16.

Disassembly

1. Remove the slot guide (38).
2. Remove and discard the trunnion seal retainer and seal (49).
3. Remove the trunnion arm (37).

Inspection

1. Inspect the trunnion arm (37) for wear or damage. Replace the trunnion arm if necessary.

Assembly

1. Install the trunnion arm (37) into the housing (1) bore. Rotate the trunnion arm to verify free movement.

NOTE: Upon removal, it is recommended that all seals, O-rings, and gaskets be replaced. During installation, lightly lubricate all seals, O-rings and gaskets with clean petroleum jelly prior to assembly. Also protect the inner diameter of seals by covering the shaft with plastic wrap. Remove the plastic wrap after the seal is installed.

2. Install a new seal and seal retainer (49).
3. Install the slot guide (38).
4. To completely reassemble the pump, refer to the assembly steps on pages 39-50. Begin with the trunnion arm assembly steps listed on page 54 and complete the assembly steps in reverse order working towards the front of the manual.

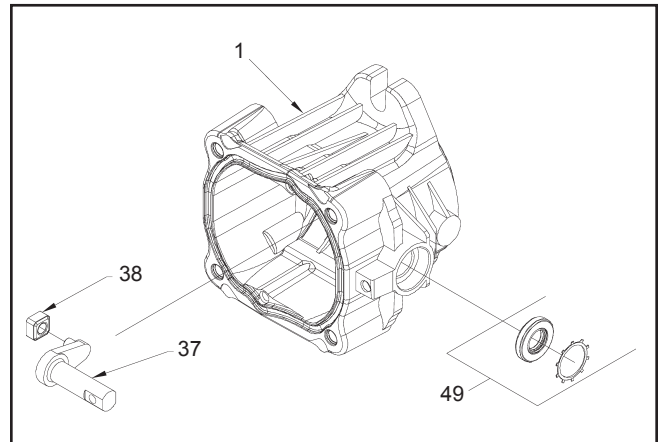
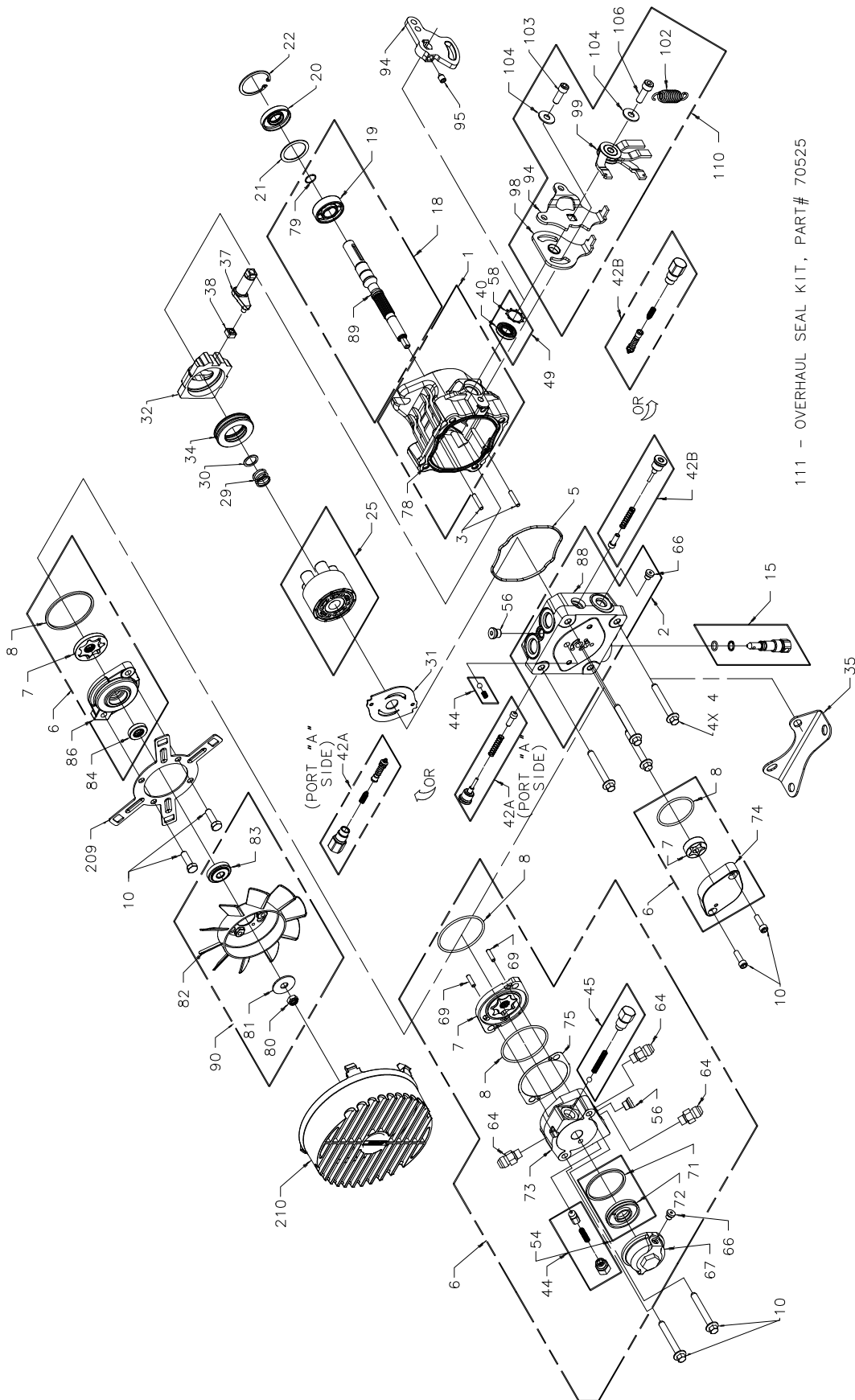

Figure 16. PG / PE Pump Trunnion Arm



111 - OVERHAUL SEAL KIT, PART# 70525

BOXES INDICATE ITEMS INCLUDED IN KITS.

Kit Number

Figure 17. PG / PE Pump

ITEM LIST - PG AND PE SERIES

Part numbers are not provided in this manual. See CD (BLN-51427) for part numbers.

No. Description

- 1 Housing Kit
- 2 End Cap Kit (W/Poppets, Standard Charge)
End Cap Kit (W/ SCR'S, Standard Charge)
End Cap Kit (W/ Poppets, Auxiliary Charge)
End Cap Kit (W/ SCR'S, Auxiliary Charge)
End Cap Kit (STD CHG) LH;SCR/HR: Poppet
End Cap Kit (STD CHG) LH:Poppet/RH:SCR
End Cap Kit (STD CHG) LH:SCR/RH:SCR
End Cap Kit (AUX CHG) LH:SCR/RH:Poppet
End Cap Kit (AUX CHG) LH:Poppet/RH:SCR
End Cap Kit (AUX CHG) LH:SCR/RHPoppet,
Thru
End Cap Kit (AUX CHG) W/Poppets, Thru
End Cap Kit (AUX CHG) W/SCR;s, Thru
End Cap Kit (AUX CHG) LH:Poppet/RH:SCR,
Thru
- 3 Straight Headless Pin
- 4 Hex Flange Bolt M8-1.25 X 60 mm LG
- 5 Housing O-Ring
- 6 Charge Pump Kit (STD)
Charge Pump Kit (STD CHG), Thru
Aux Pump Kit (AL., 15T Splined, 2-7/16 SAE
Ports)
Aux Pump Kit (AL., 15T Splined, 3-7/16 SAE
Ports)
- 7 STD Gerotor Assy (.11 cu. In/rev D-Drive)
Auxiliary Gerotor & Housing Assembly
- 8 O-Ring
- 10 Socket Head Screw M6 x 1.0-20 mm Lg (STD
Chg)
Hex Flange Bolt 8M-1.25 x 60 mm (Aux Chg)
Cap Screw, Hex 5/16-18 x 1.00 (Thru Chg)
Supplied with item # 2 only
- 15 Bypass Valve Kit (Blank)
Bypass Valve Kit (0.031")
Bypass Valve Kit (0.043")
- 18 Pump Shaft Kit (Blind 15mm Keyway
W/Std Chg)
Pump Shaft Kit (Blind 15mm Keyway
W/Aux Chg)
Pump Shaft Kit (9 Tooth W/Std Chg)
Pump Shaft Kit (9 Tooth W/Aux Chg)
Pump Shaft Kit (15mm Keyed, Std Chg, Thru)
Pump Shaft Kit (9 Tooth Thru Chg)
Pump Shaft Kit (Tapered)
- 19 Ball Bearing 17 X 40 X 12
- 20 Lip Seal 17 X 40 X 7 PTC
- 21 Spacer
- 22 Retaining Ring
- 25 Cylinder Block Kit
- 29 Block Spring
- 30 Block Thrust Washer
- 31 Valve Plate
- 32 Swashplate

No. Description

- 34 Ball Thrust Bearing
- 35 Stud, Torque
- 37 Trunnion Arm
Trunnion, RTN
- 38 Slot Guide
- 42 Check Valve Kit (blank Orifice)
Check Valve Kit (0.024" Orifice)
Check Valve Kit (0.031" Orifice)
Check Valve Kit (0.044" Orifice)
System Check / Relief Kit
System Check Relief Kit (.031" Orifice)
Shock Valve Kit
- 44 Charge Relief Valve Kit (1/4" Plastic Ball
& 50654 Spring)
Charge Relief Valve Kit (9/16" SAE Plug
& 3101536 Spring)
- 45 Aux Relief Valve Kit (1/4" Steel Ball)
Aux Relief Valve Kit (Aux Poppet)
- 49 Trunnion Seal/Retainer Kit
- 54 Auxiliary Filter Kit
- 56 Straight Thread Plug
- 59 O-Ring
- 64 Connector
- 66 5/16" SAE Plug
- 67 Filter Cover
- 69 Straight Headless Pin
- 75 Shim - Charge Pump (.002 - Red)
- 85 R-Ring - 144
- 90 Hub / 6" Fan Kit
Hub / 7" CCW Fan Kit
Hub / 7" CW Fan Kit
Hug / 7" Fan Kit
- 94 Control Arm
- 95 Screw, Soc Head
- 98 Return Arm
- 99 Inner Scissor Arm
- 100 Outer Scissor Arm
- 101 Spacer RTN
- 102 Spring, Extension
- 103 Screw, 5/16 x .875 (patch)
- 104 Washer .34 x .88 x .06
- 105 Washer, Nylon
- 106 Bolt
- 107 Nut, Hex
- 110 Kit, RTN, STD
Kit, RTN, CW
Kit, RTN, CCW
- 111 Seal Kit
- 209 Shroud Bracket
- 210 Shroud

REPAIR - PJ SERIES PUMP

Repair - PJ Series Pump	55-72
How to Use This Manual	55
General Instructions	55
Tools and Torques	56
Return to Neutral Linkage	57
Standard Control Arm Linkage	58
Fan Assembly	58
Input Shaft Seal	59
Trunnion Arm Seal	59
Check Valves	60
Shock Valves	60
Bypass	61
Charge Pump-Standard or Thru Shaft	62
Auxiliary Pump	63
End Cap	64
Cylinder Block	65
Block Spring and Thrust Bearings	66
Swashplate and Cradle Bearings	66
Input Shaft	67
Trunnion Arm	68
Parts List	70-71

HOW TO USE THIS MANUAL

Each assembly is provided with an exploded view showing the parts involved. **The item reference numbers in each illustration are for assembly instructions only.** See pages 70 and 71 for part names and descriptions. A complete exploded view and item list of the pump is provided at the end of this section.

GENERAL INSTRUCTIONS

Cleanliness is a primary means of ensuring satisfactory life on repaired pumps. Thoroughly clean all exposed surfaces prior to any type of maintenance. Cleaning of all parts by using a solvent wash and air drying is usually adequate. As with any precision equipment, all parts must be kept free of foreign material and chemicals.

Protect all exposed sealing surfaces and open cavities from damage and foreign material. The external surfaces should be cleaned before beginning any repairs.

Lip-type seals (shaft seals) are used on the input shaft and directional control shaft of each pump. These seals can be replaced without major disassembly of the unit. However, replacement of these seals generally requires removal of the pump from the machine. Upon removal, it is recommended that all seals, O-rings and gaskets be replaced.

During installation, lightly lubricate all seals, O-rings and gaskets with clean petroleum jelly prior to assembly. Also protect the inner diameter of the seals by covering the shaft with a cellophane (plastic wrap, etc.) material.

Parts requiring replacement must be replaced from the appropriate kits identified in the Items Listing, found at the end of this manual. Use only original Hydro-Gear replacement parts found listed in BLN-51427 (CD).

TOOLS AND TORQUES

Miscellaneous	3/8-Inch Drive Ratchet and Sockets
P Series Service & Repair Manual	7/16-inch Socket
Torque Wrench	1/2-inch Socket
Scribe, Paint Pen, or Marker	9/16-inch Socket
Seal Hook with a Magnet	5/8-inch Socket
Flat Blade Screwdriver	11/16-inch Socket
	10-mm Socket
Pliers	
Internal Snap Ring	Combination Wrenches
	7/16 inch
Allen Wrenches	1/2 inch
5mm	9/16 inch
1/8 inch	5/8 inch
3/16 inch	11/16 inch
1/4 inch	7/8 inch
	10 mm

Table 1. Required Tools

Item # and/or Description	Torque
Case Drain (fitting torque)	200-250 lb-in (22.6-28.2 Nm)
System Port (fitting torque)	370-470 lb-in (41.8-53.1 Nm)
Inlet (fitting torque)	200-250 lb-in (22.6-28.2 Nm)
4, End Cap/Adapter Plate Bolts	180-220 lb-in (20.3-24.9 Nm)
10, Cap Screw	180-220 lb-in (20.3-24.9 Nm)
15, Bypass Valve	110-130 lb-in (12.4-14.6 Nm)
42A, 42B, Shock Valves/Check Plugs	180-240 lb-in (20.3-27.1 Nm)
44, System Charge Relief Kit (Aux Chg)	180-240 lb-in (20.3-27.1 Nm)
45, Aux Relief Valve Kit	180-240 lb-in (20.3-27.1 Nm)
56, Diagnostic Plug	84-120 lb-in (9.4-13.5 Nm)
66, Filter Cover Plug	55-85 lb-in (6.2-9.6 Nm)
67, Filter Cover	200-275 lb-in (22.6-31.1 Nm)
103, Screw 5/16 x .875	200-240 lb-in (22.6-27.1 Nm)
106, Bolt	180-220 lb-in (20.3-24.9 Nm)
107, Nut, Hex Lock 5/16-24UNF	180-220 lb-in (20.3-24.9 Nm)

Table 2. PJ Pump Torque Values

PJ SERIES PUMP REPAIR

REMOVAL, INSPECTION AND/OR REPLACEMENT OF RETURN TO NEUTRAL ASSEMBLY

Refer to Figure 1.

Prior to disassembly, note the position of the scissor arm brackets and the tab on the outer control arm bracket.

Disassembly

CAUTION: The spring used on the return to neutral linkage is under tension. To avoid possible injury, use care and proper protection during disassembly and assembly of the return to neutral linkage.

1. Loosen (but do not remove) the bolt (106)/nut (107).
2. To relieve spring tension, carefully pry up on the outer scissor control arm until it releases from the tab on the outer control arm bracket.
3. Remove the spring (102), bolt (106)/nut (107) and washer (104).
4. Remove the scissor arm (99).
5. Remove the outer control arm bracket(94), bolt (103), washer (104) and the inner return arm bracket(98).

Inspection

1. With the arm control linkage removed, inspect the trunnion arm (37) and trunnion arm seal (49).
2. Inspect scissor arm (99) and all other linkage parts for damage, corrosion or wear.

Assembly

1. Install the inner return arm bracket(98), washer (104) and bolt (103).

NOTE: Do not over tighten the bolt (103). The bracket must move freely.

2. Install the inner scissor control arm(94)
3. Tighten washer (104), and nut (103) to the correct torque value. See page 74.
4. Install the scissor arm(99).
5. Install washer(104) and bolt (106)/nut (107) to the correct torque value. See page 74.
5. Install the spring (102).

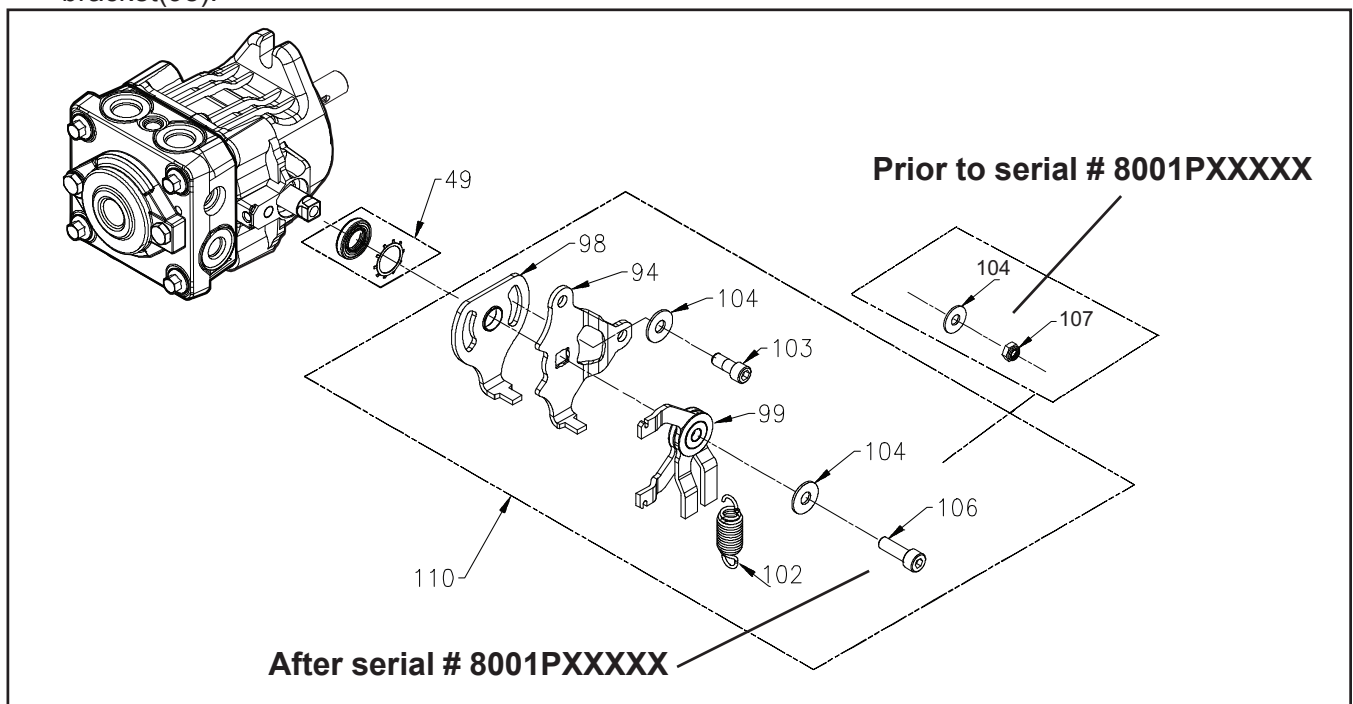

Figure 1. PJ Pump Return to Neutral

REMOVAL, INSPECTION AND/OR REPLACEMENT OF CONTROL ARM

Refer to Figure 2.

Disassembly

1. Remove the bolt (106)/nut (107), washer (104) and bushing (101).
2. Remove the outer control arm bracket.
3. Remove bolt (103), washer (104) and the inner control arm bracket.

Inspection

1. With the arm control linkage removed, inspect the trunnion arm (37) and trunnion arm seal (49).
2. Inspect bushing (101) and all other linkage parts for damage, corrosion or wear.

Assembly

1. Install the inner control arm bracket, washer (104) and bolt (103).

NOTE: Do not over tighten the bolt (103). The bracket must move freely.

2. Install the outer control arm bracket, bushing (101), washer (104), and bolt (106)/nut(107). Tighten to the correct torque value. See page 56.

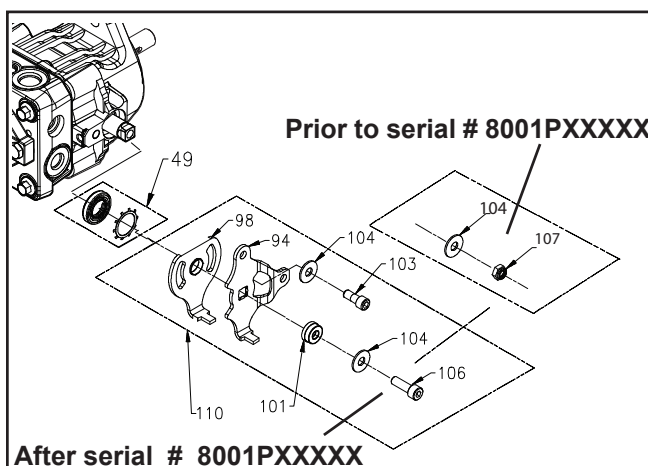

Figure 2. PJ Pump Standard Control Arm

REMOVAL, INSPECTION AND/OR REPLACEMENT OF FAN ASSEMBLY

Refer to Figure 3.

Disassembly

1. Remove the fan shroud (210) from the mounting bracket (209) by carefully pushing down on the shroud tabs.
2. Remove the nut (106) and fan assembly (90).
3. Remove the bolts (10) and bracket (209).

Inspection

Inspect the fan shroud (210), fan assembly (90) and mounting bracket (209) for damage.

Assembly

1. To install the mounting bracket (209), align and insert the bolts (10) into the bracket and charge pump cover. While holding the charge cover in place, tighten the bolts (10) per table 2, page 56.
2. Install the fan and washer assembly onto the shaft.
3. Install the nut (106) and tighten per table 2, page 56.
4. Install the fan shroud (210) onto the mounting bracket (209). Make sure that all shroud lock tabs are fully engaged in the mounting bracket slots.

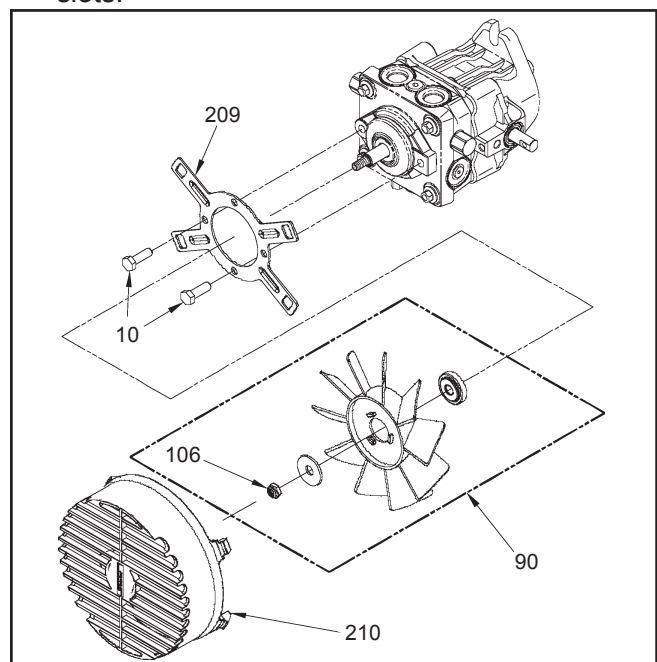

REMOVAL, INSPECTION AND/OR REPLACEMENT OF INPUT SHAFT SEAL

Refer to Figure 4.

Disassembly

1. Remove retaining ring (22) from housing.
2. Remove lip seal (20). Care must be taken to prevent damage to the housing bore, shaft sealing surface, or bearing. Once removed, the seal is not reusable.

Inspection

With seal removed inspect the spacer (21) and housing (1) bore for damage, corrosion or wear.

Assembly

1. Lubricate the new lip seal (20) inside diameter with petroleum jelly.
2. Wrap the input shaft with plastic wrap to prevent damage to the inner surface of the lip seal (20).
3. Slide spacer (21) and seal (20) over the input shaft so that lettering on the seal faces out.
4. Press the lip seal (20) into the housing bore. Insure the lip seal (20), input shaft or housing (1) bore does not become damaged.
5. Install the retaining ring (22) into the housing bore groove.

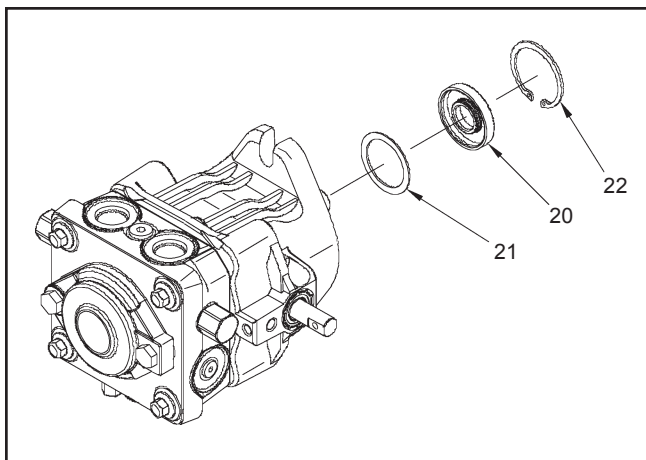

Figure 4. PJ Pump Input Shaft Seal

REMOVAL, INSPECTION AND/OR REPLACEMENT OF TRUNNION ARM SEAL

Refer to Figure 5.

Disassembly

1. Remove the RTN assembly or control arm.
2. Remove the retainer and lip seal (49) from the housing. Care must be taken to prevent damage to the housing trunnion bore, trunnion arm and sealing surface. Once removed the retainer and lip seal are not reusable.

Inspection

With the lip seal (49) removed, inspect the area for corrosion and wear. Inspect the trunnion bore area sealing surface for damage or wear.

Assembly

1. Lubricate the new lip seal (49) inside diameter with petroleum jelly.
2. Wrap the trunnion arm with plastic wrap to prevent damage to the inner surface of the lip seal (49).
3. Slide the lip seal (49) over the trunnion arm so that the lettering on the seal (49) faces out.
4. Press the lip seal (49) into the housing bore. Insure the seal (49), trunnion arm, and housing bore do not become damaged. Remove the plastic wrap.
5. Install the retainer from (49) over the trunnion arm on top of the lip seal. Press into the trunnion seal bore in the housing until the retainer mates against the trunnion seal.
6. Install the RTN assembly or control arm.

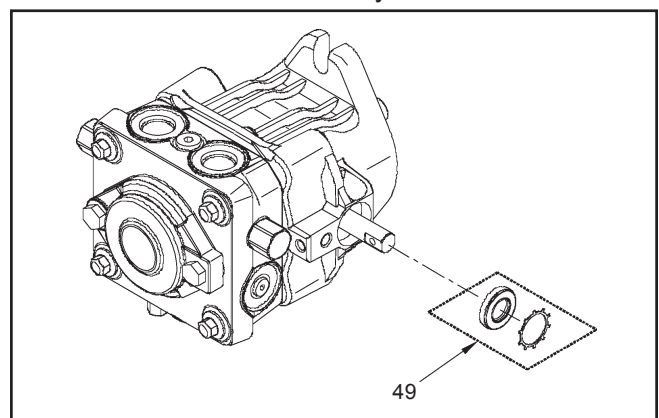

Figure 5. PJ Pump Trunnion Arm Seal

REMOVAL, INSPECTION AND/OR REPLACEMENT OF CHECK VALVES

Refer to Figure 6.

Perform disassembly, inspection and assembly on check valves one side at a time. Some units vary in “A” side to “B” side check configuration.

Disassembly

1. Remove the check valve (42) with an 1/4” allen wrench.
2. Remove the valve spring and poppet from the end cap.

Inspection

1. Inspect the poppets and mating seats in the end cap for damage or foreign material.

Assembly

1. Lay the pump on its side, so the check plug port is horizontal.
2. Insert the check plug, spring and poppet (42) as one assembly into the check plug port. Tighten, reference Table 2, page 56 for torque values.
3. Repeat disassembly, inspection and assembly for the opposite port side.

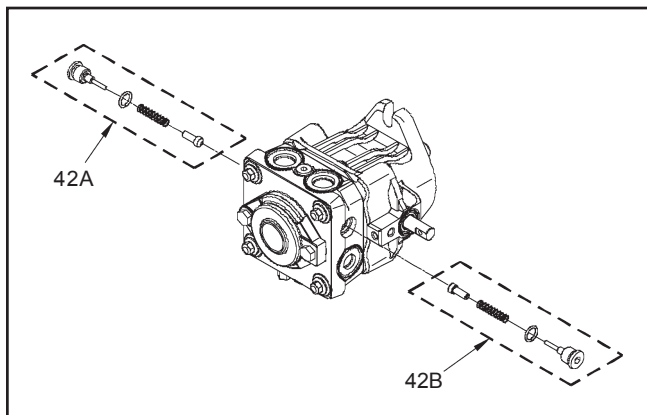

Figure 6. PJ Pump Check Valves

REMOVAL, INSPECTION AND/OR REPLACEMENT OF SYSTEM CHECK RELIEFS (SCR'S) OR SHOCK VALVES

Refer to Figure 7.

Disassembly

Perform disassembly, inspection and assembly on SCR/shock valve one side at a time. Some units vary in “A” side to “B” side configuration.

1. Remove the SCR (42) with a 7/8” wrench or the shock valve (42) with an 11/16” wrench.
2. Remove the check relief/shock valve spring and the check relief/shock valve from the end cap.

Inspection

1. Inspect the check relief or shock valve (42) and mating seat in the end cap for damage or foreign material.

Assembly

1. Lay the pump on its side, so the check plug port is horizontal.
2. Insert the system check relief spring and check relief or shock valve spring and shock valve as one assembly into the check plug port. Tighten to the correct torque value. See page 56.
3. Repeat disassembly, inspection and assembly for the opposite port side.

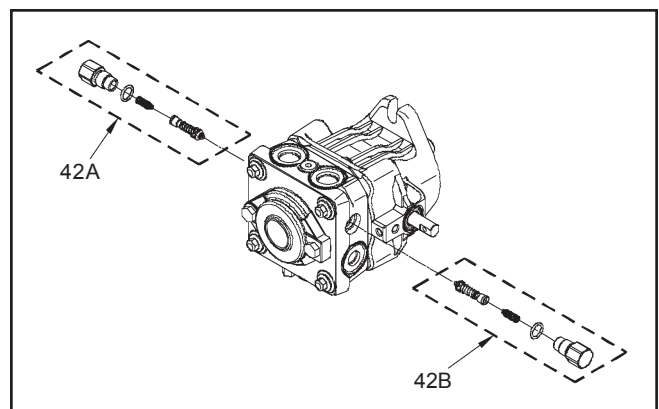

Figure 7. PJ Pump Shock Valves

REMOVAL, INSPECTION AND /OR REPLACEMENT OF THE BYPASS

Refer to Figure 8.

Disassembly

1. Loosen the bypass valve (15) using a 5/8" wrench.
2. Remove the bypass (15) from the end cap (2).

Inspection

1. Inspect the bypass O-rings and mating seats in the end cap (2) for damage or foreign materials.
2. If damaged or worn replace bypass (15)

Assembly

1. Lay the pump on its side, so the bypass port is horizontal.
2. Insert the bypass (15) into the bypass port on the end cap (2). Tighten to the proper torque value. See page 56.

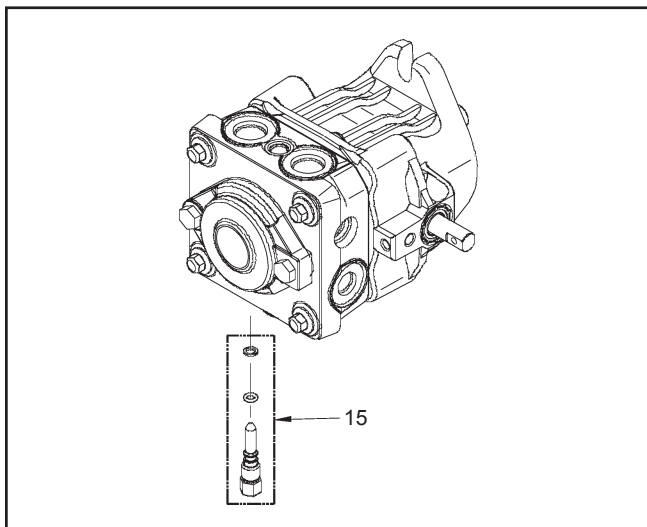

Figure 8. PJ Pump Bypass

REMOVAL, INSPECTION AND ASSEMBLY OF STANDARD OR THRU SHAFT CHARGE PUMP

Refer to Figure 9.

Disassembly

1. Prior to removal of the charge pump cover, place a mark on the cover and end cap for alignment at assembly.
2. Using a 1/2 inch wrench, or 5 mm allen wrench, loosen the charge pump cover bolts (10) from the end cap (2). While holding the charge cover in place, remove the charge cover bolts (10).
3. Remove the charge cover, O-ring and gerotor items (6). Carefully check for and remove the charge spring and charge ball (44).
4. For the Thru Shaft charge pump, remove the shaft seal.

Inspection

1. Inspect the charge cover O-ring and running surfaces for damage. Inspect the spring, check ball (44), and mating seat in the end cap (2) for damage or foreign material.

NOTE: If the end cap (2) is to be removed from the housing, do not assemble the charge pump (6) until the end cap is installed on the housing.

2. Inspect the charge cover bore for damage, corrosion or wear.

Assembly

NOTE: For the Thru Shaft charge pump follow steps 1-8. For the Standard charge pump follow steps 3-8.

1. Lubricate the new shaft seal with petroleum jelly.
2. Press the shaft seal into the charge cover. Be careful not to damage the seal or charge cover bore.
3. Position the pump with the input shaft down, and the end cap (2) horizontal. Place the charge ball (44) in the end cap (2) charge passage so the ball mates to the end cap (2) charge ball seat. Place the charge spring, on top of the charge ball.
4. Insert the inner gerotor over input shaft (18).
5. Align the outer gerotor to fit over the inner gerotor.
6. Insert the O-ring (8) into the groove in the charge cover.
7. Position the charge cover and O-ring with the aligning mark on the end cap. Place the charge cover and O-ring with aligning mark on the end cap. Place the charge cover and O-ring as one piece over the charge spring and gerotor assembly. Insure the spring fits into the charge cover spring retaining groove.
8. Align and insert the charge pump cover bolts (10) into the end cap (2). Tighten to the correct torque value. See Table 2, page 56. (Torque Values.)

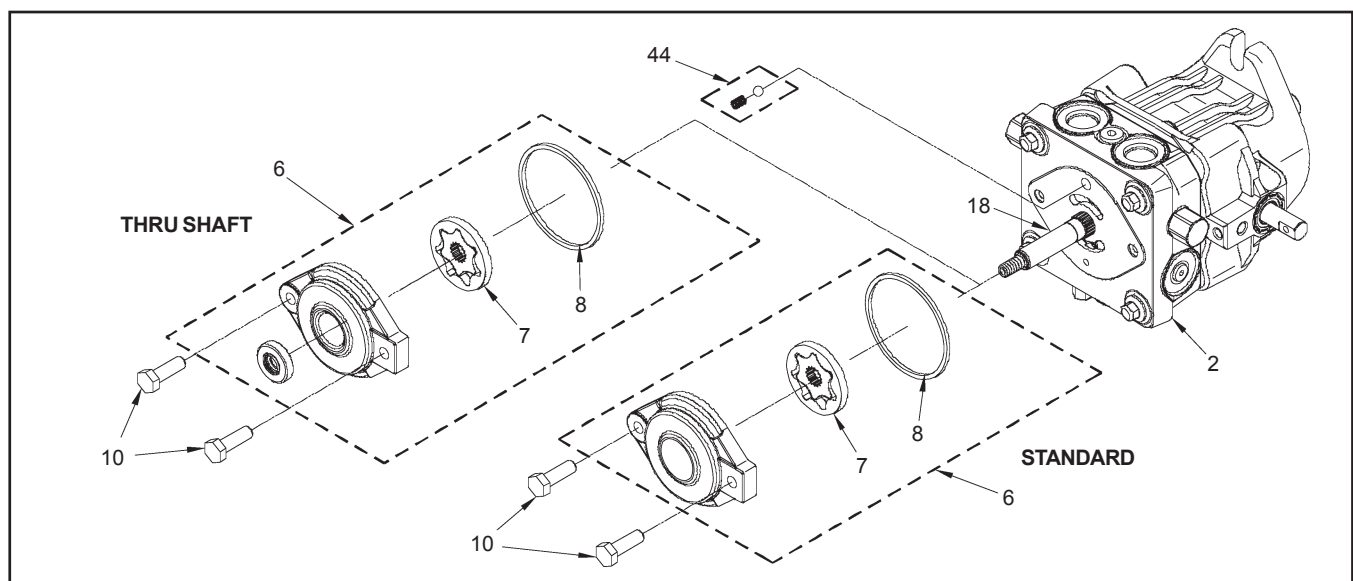

Figure 9. PJ Pump Standard or Thru Shaft Charge Pump

REMOVAL, INSPECTION AND/OR REPLACEMENT OF AUXILIARY PUMP (IF EQUIPPED)

Refer to Figure 10.

Disassembly

1. Prior to removal of the auxiliary pump, place a mark on the auxiliary pump, charge pump (7) and end cap (2) for alignment at assembly.
2. Use a 10mm wrench to loosen the auxiliary pump bolts (10) from the end cap (2). While holding the auxiliary pump in place, remove the bolts (10).
3. Remove the auxiliary pump, gasket (75), O-ring (8) and charge pump (7). While removing the charge pump, be sure to retain the spring and ball (44A) housed in the end cap (2).
4. Remove the plug (66) from the filter cover (67).
5. Use a 7/8 inch wrench to remove the filter cover assembly (67) from the auxiliary pump.
6. Remove the O-ring and filter (54).
7. Remove the charge relief valve assembly (44) and auxiliary relief valve assembly (45) from the auxiliary pump.

Inspection

1. With the auxiliary pump removed, inspect the pump running surfaces for wear or damage.
2. Inspect all O-rings, gasket and mounting seats.

3. Inspect the filter cover assembly threads and filter for wear, damage or foreign material.

Assembly

1. Install the check ball, spring, and cap as one assembly (45) into the auxiliary relief valve port. Tighten to the correct torque value. See page 56.
2. Install the poppet, spring and cap (44) as one assembly into the charge relief port. Tighten to the correct torque value. See page 56.
3. Install the filter (54) and O-ring onto the filter cover assembly (67). Install the assembly (67) into the auxiliary pump and tighten. Install plug (66) into the filter cover (67).
4. Lay the PJ Pump (input shaft down), so the end cap is horizontal. Install the O-ring (8) into the charge pump (7).
5. Install the gasket (75) onto the auxiliary pump.
6. Make sure that the ball and spring (44A) are seated in the end cap (2), then position the auxiliary pump and gasket with the aligning mark on the charge pump (7). Insure that the pump fully engages the alignment pins (69).
7. Align and insert the bolts (10) into the auxiliary pump. While holding the auxiliary pump and charge pump in place, tighten the bolts (10) per table 2, page 56.

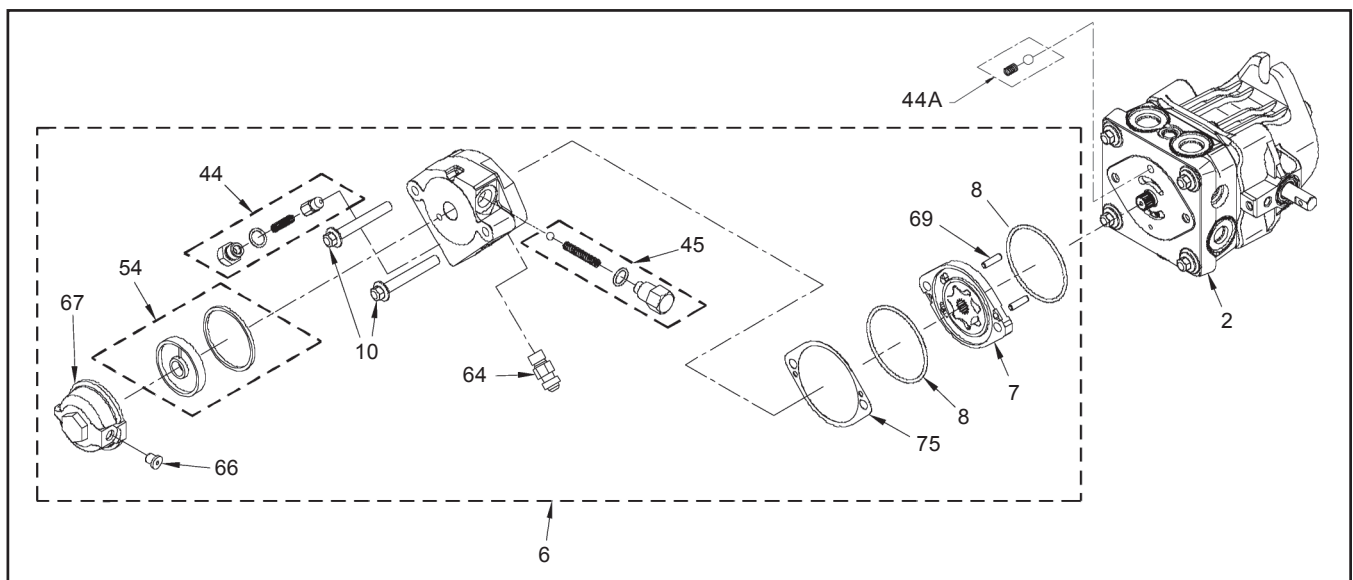

Figure 10. Auxiliary Pump

REMOVAL, INSPECTION AND ASSEMBLY OF THE END CAP

Refer to Figure 11.

Disassembly

1. Remove charge pump. (See page 62).
2. Using a 10 mm wrench, loosen the end cap bolts (4) evenly.
3. Hold the end cap (2) in place and remove the four end cap bolts (4).
4. Slowly remove the end cap (2).
5. Remove housing gasket (5).

Inspection

1. Inspect the end cap (2) body for damage, nicks or unusual wear patterns. Replace if necessary.
2. Inspect the running surface (side that contacts the cylinder block) of the end cap (2). The running surface may show evidence of minor abrasive rings, this is normal.

Grooving in the end cap, or material transfer that is evident when the surface is checked by dragging a fingernail across it, would be cause for replacement of the end cap (2).

3. Replace the housing gasket (5) with a new gasket before assembly.

Assembly

1. Install housing gasket (5) into gasket seat of housing (1).
2. Lubricate the cylinder block (25) to end cap (2) mating surface with clean oil prior to installation.
3. Install end cap (2). Before installing the four end cap bolts (4), push down on end cap (92) verifying alignment and insuring that the cylinder block pistons spring back and forth. Install end cap bolts (4). Tighten to the correct torque value. See Table 2, page 56 (Torque Values).
4. Install the charge pump. (See page 62.)

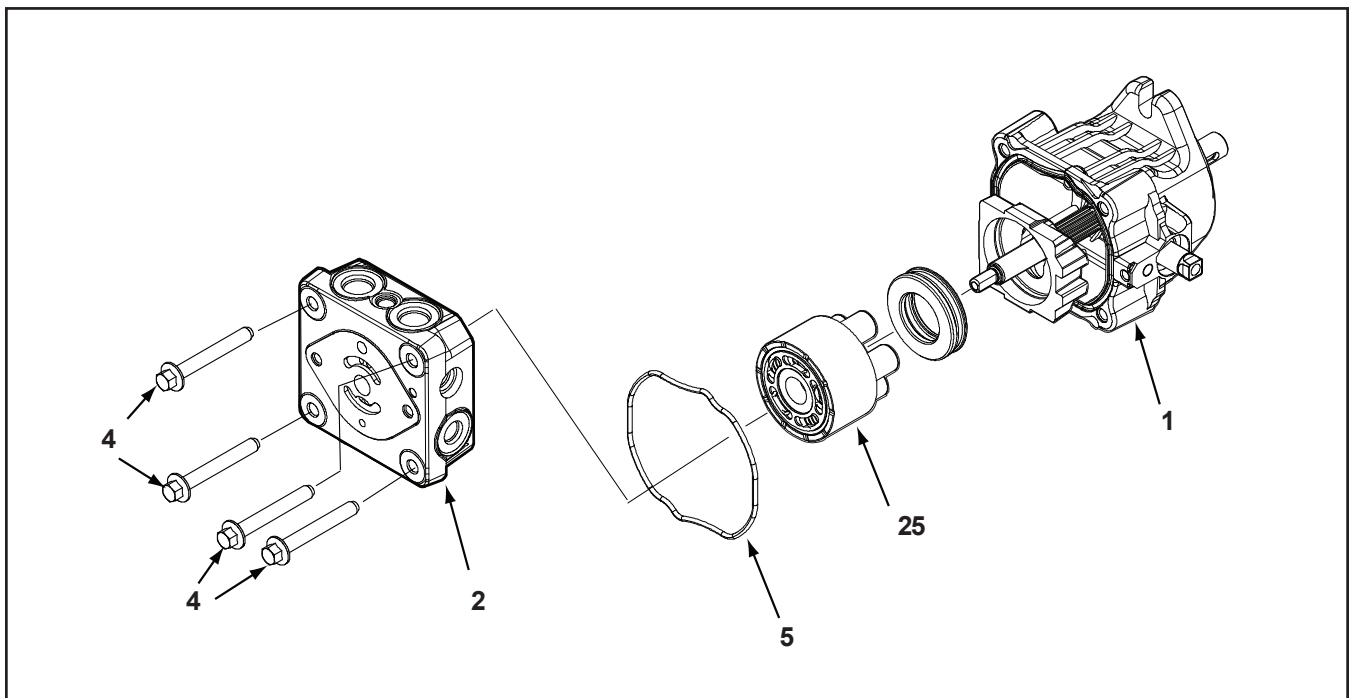

Figure 11. PJ Pump End Cap

REMOVAL, INSPECTION AND ASSEMBLY OF THE CYLINDER BLOCK

Refer to Figure 12.

Disassembly

1. Remove charge pump. (See page 62).
2. Remove end cap. (See page 64).
3. Tilt the pump on its side and drain remaining oil. Lift out the cylinder block assembly (25).
4. Remove the pistons, springs and piston seats.

Inspection

1. Inspect the running surface of the cylinder block and piston ends for damage, nicks or unusual wear patterns. The running surface may show evidence of minor abrasion. This will be normal wear. If grooved or smeared, replace with a new cylinder block assembly.
2. Inspect the piston springs for distortion or breaks. If necessary, replace with a new cylinder block kit.
3. Inspect the piston seats. Residual oil may cause these to remain stuck to the inside of the pistons.

Assembly

1. Apply a thin layer of clean oil to the pistons and springs.

2. Install piston seats into the end of the pistons.
3. Install springs into the pistons.
4. Install each piston, spring and seat assembly into the cylinder block.
5. With the pump housing tilted on its side, install the cylinder block assembly (25) with pistons contacting the thrust bearing.

NOTE: To check if the cylinder block assembly is installed correctly, position the pump housing vertically and support housing at the mounting flange. Push down on the cylinder block. The cylinder block must move up and down freely. If it does not, remove the cylinder block assembly. Place a rubber band around the cylinder block pistons to hold them in position during installation. Then after installation cut the rubber band and remove it. Check cylinder block assembly for spring action.

6. Install the end cap. (See page 64)
7. Install the charge pump. (See page 62)

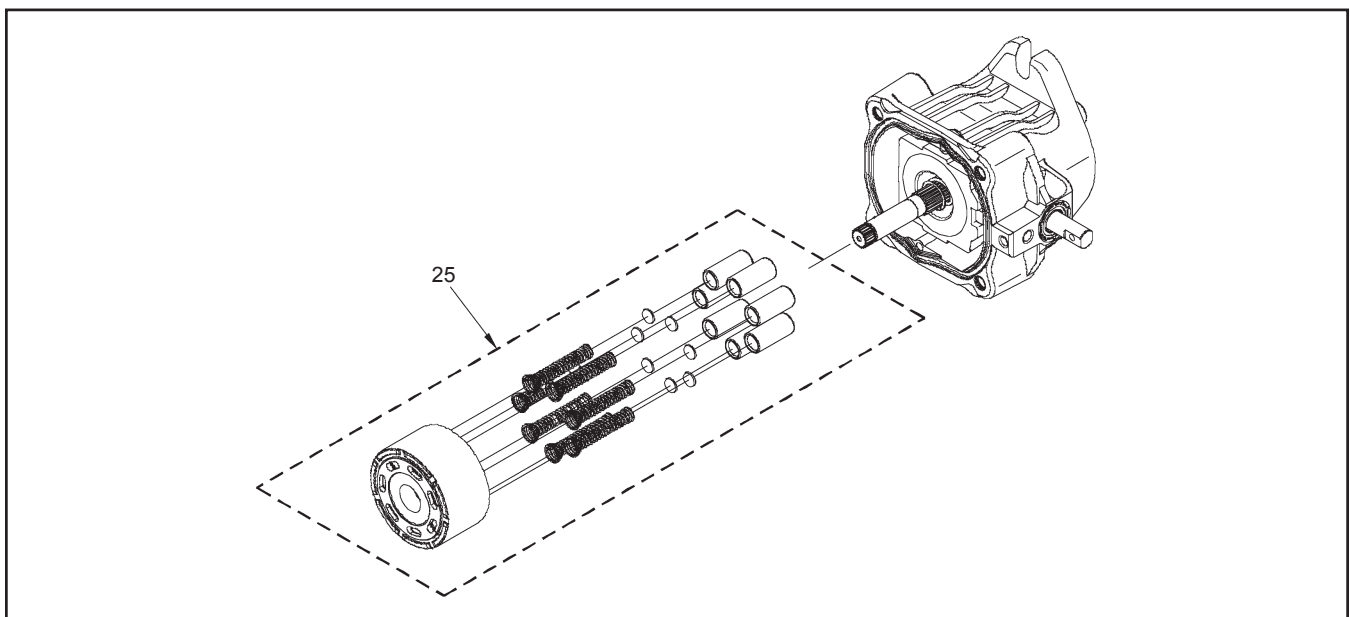

Figure 12. PJ Pump Cylinder Block

REMOVAL, INSPECTION AND ASSEMBLY OF BLOCK SPRING AND THRUST BEARING

Refer to Figure 13.

Disassembly

1. Remove the block spring (29).
2. Remove the block thrust washer (30) and thrust bearing (34).

Inspection

1. Inspect and replace the block spring (29) if it is distorted or broken.
2. Inspect the running surface of the bearing races for damage, nicks or unusual wear patterns. The running surface may show evidence of minor abrasion. This will be normal wear.

Inspect the bearings for free movement. Inspect the bearing cage for distortion or damage. Replace if necessary.

Assembly

1. Install thrust bearing and race assembly (34).
2. Install the block thrust washer (30).

NOTE: The difference in race thicknesses: The thin race seats into the swashplate (32). The thicker race will be installed toward the piston noses.

3. Install block spring (29).

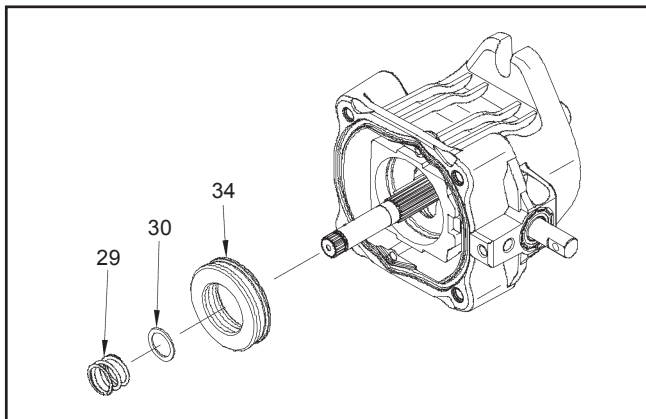

Figure 13. Pump Block Spring and Thrust Bearing

REMOVAL, INSPECTION AND ASSEMBLY OF SWASHPLATE AND CRADLE BEARINGS

Refer to Figure 14.

Disassembly

1. Remove the swashplate (32).

Inspection

1. Inspect the running surface of the bearing pocket of swashplate (32) for damage, nicks or unusual wear patterns. The running surface may show evidence of minor abrasion. This is normal wear. Inspect the cradle bearing side of the swashplate (32) for damage. Replace if necessary.
2. Inspect the cradle bearings attached to the inside of the housing (1) for normal wear patterns and placement, and insure they are staked securely in place. If the bearings are damaged, replace housing (1).

NOTE: The cradle bearings will have discoloration due to normal wear. Under normal circumstances, this will not warrant replacement.

Assembly

1. Install swashplate (32) by holding trunnion arm's slot guide (38) with a flat tip screwdriver. Use the screwdriver to hold the slot guide in place while positioning the swashplate (32) onto the cradle bearing in the housing (1).
2. Rotate trunnion arm (37) to verify that the swashplate moves freely.

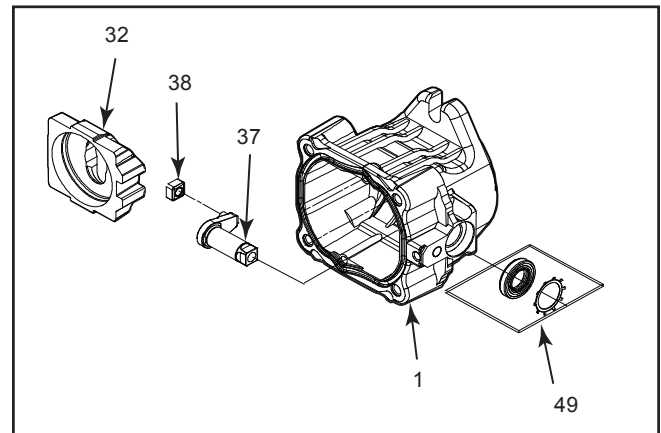

Figure 14. PJ Pump Swashplate and Cradle Bearings

REMOVAL, INSPECTION AND ASSEMBLY OF INPUT SHAFT

Refer to Figure 15.

Disassembly

1. Remove the retaining ring (22).
2. Remove the lip seal (20).
3. Remove the spacer (21).
4. Remove the shaft (18) and bearing (19) assembly from the pump.

Inspection

1. Inspect the input shaft (18) for worn splines, surface damage, or keyway damage. Replace shaft assembly if necessary.
2. Inspect the bearing (19) for evidence of scoring, corrosion, or damage. If the bearing must be replaced, remove the retaining ring and use a press or bearing puller to remove the bearing.
3. Inspect and replace the spacer (21) if it is bent or broken.
4. Inspect and replace the retaining ring (22) if it is bent or broken.

NOTE: Upon removal, all seals, O-rings and gaskets should be replaced.

Assembly

NOTE: If trunnion arm is to be removed, do not assemble input shaft until the trunnion arm is installed.

NOTE: During installation, lightly lubricate all seals, O-rings and gaskets with clean petroleum jelly prior to assembly. Also, protect the inner diameter of seals by covering the shaft with plastic wrap.

1. If removed, press bearing (19) onto shaft (18) tight against the shoulder of the shaft. Install retaining ring onto the shaft (18).
2. Install input shaft assembly (18) into the housing (1) bore. Light tapping with a rubber mallet may be necessary on the input shaft (18) once the bearing is aligned with the housing (1) bore. Verify that the shaft rotates smoothly.
3. Install spacer (21).
4. Install new lip seal (20) with the flat side of the seal toward the outside of the pump.
5. Remove the plastic wrap.
6. Install retaining ring (22).

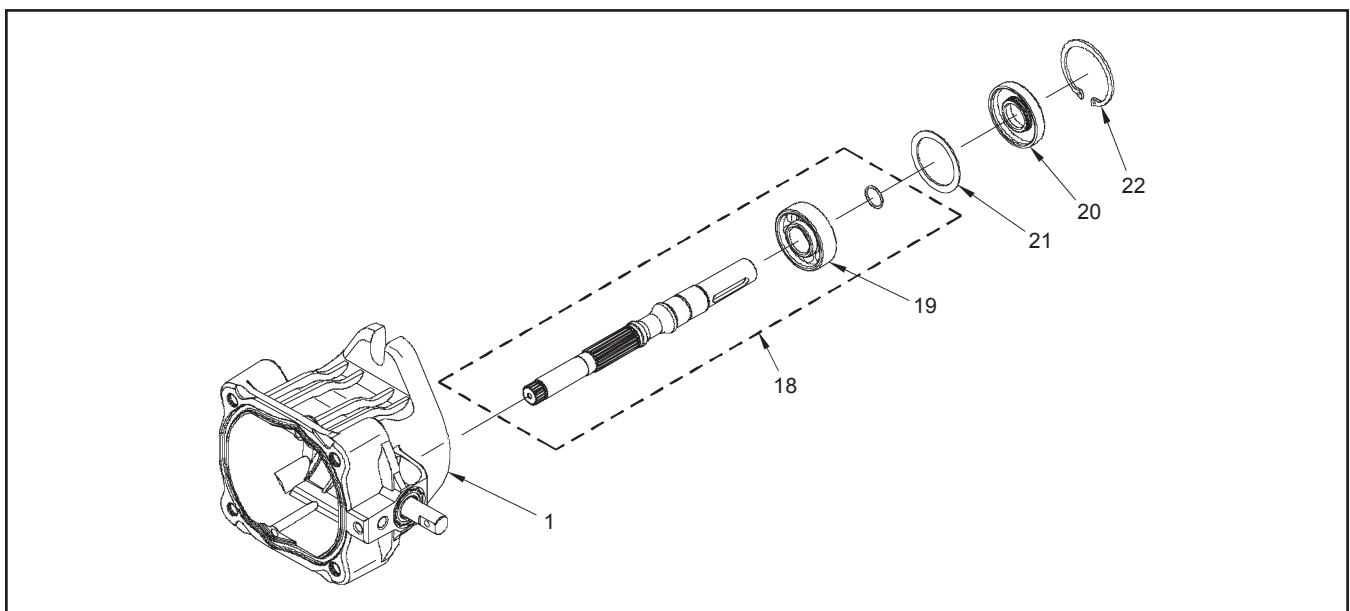

Figure 15. PJ Pump Input Shaft

REMOVAL, INSPECTION AND INSTALLATION OF TRUNNION ARM

Refer to Figure 16.

Disassembly

1. Remove the slot guide (38).
2. Remove and discard the trunnion seal retainer and seal (49).
3. Remove the trunnion arm (37).

Inspection

1. Inspect the trunnion arm (37) for wear or damage. Replace the trunnion arm if necessary.
2. Check for excessive play between trunnion arm (37) and housing (1). Replace housing if necessary.

Assembly

1. Install the trunnion arm (37) into the housing (1) bore. Rotate the trunnion arm to verify free movement.
2. Install a new seal and seal retainer (49).
3. Install slot guide (38).
4. To completely assembly the pump, refer to the assembly steps on pages 57-68. Begin with the trunnion arm assembly steps listed on page 68 and complete the assembly steps in reverse order working toward the front of the manual.

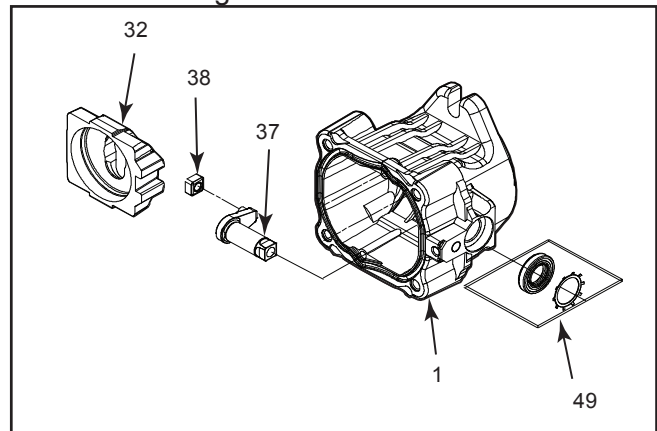
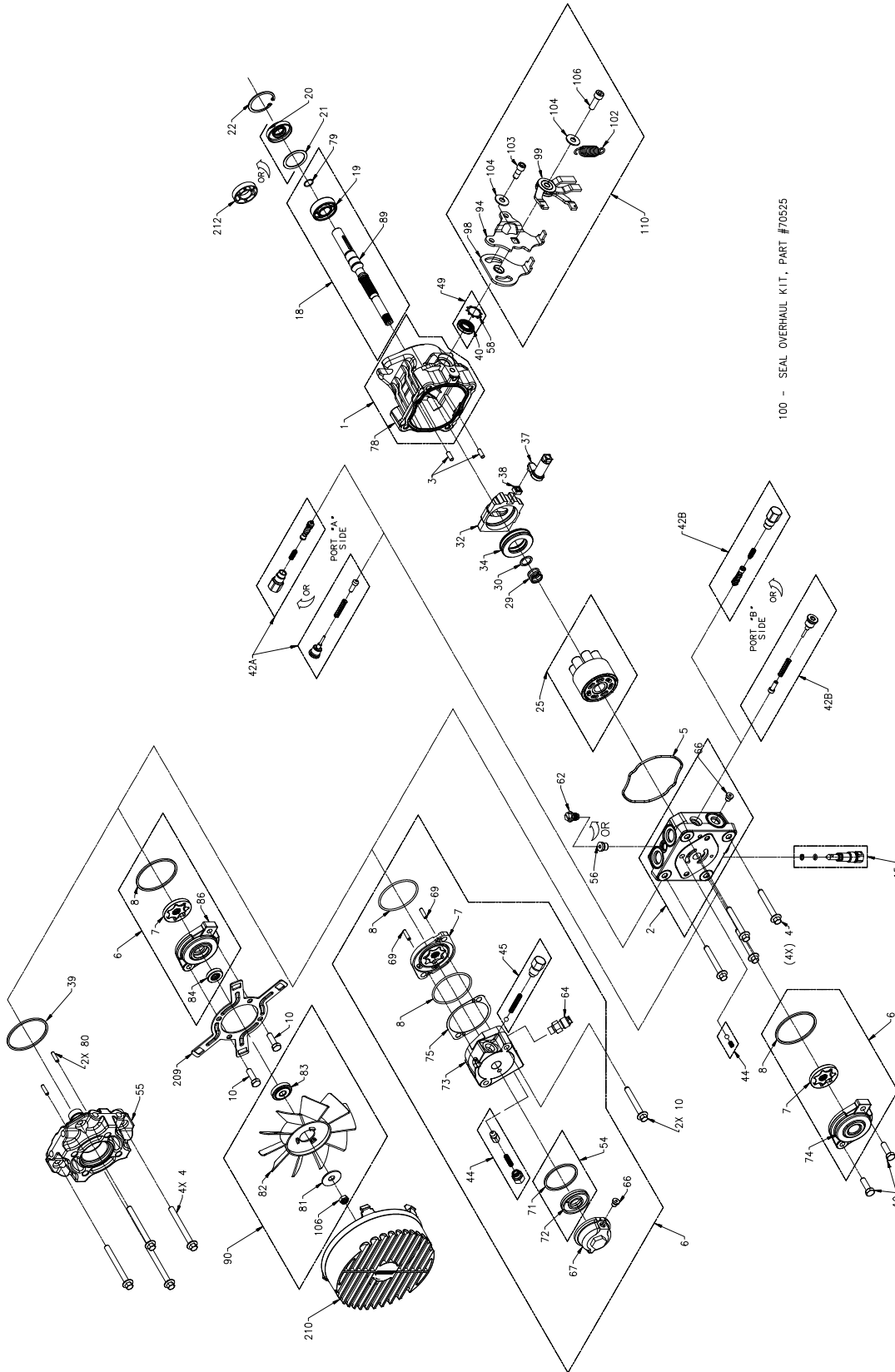

Figure 16. PJ Pump Trunnion Arm



BOXES INDICATE ITEMS INCLUDED IN KITS.

Kit Number

Figure 17. PJ Pump

ITEM LIST - PJ SERIES

Part numbers are not provided in this manual. See CD (BLN-51427) for part numbers.

No.	Description	No.	Description
1	Housing Kit	34	Ball Thrust Bearing
2	End Cap Kit (W/Poppets, Standard Charge)	35	Stud, Torque
	End Cap Kit (W/ SCR'S, Standard Charge)	37	Trunnion Arm
	End Cap Kit (W/ Poppets, Auxiliary Charge)		Trunnion, RTN
	End Cap Kit (W/ SCR'S, Auxiliary Charge)	38	Slot Guide
	End Cap Kit (STD CHG) LH;SCR/HR: Poppet	42	Check Valve Kit (blank Orifice)
	End Cap Kit (STD CHG) LH:Poppet/RH:SCR		Check Valve Kit (0.024" Orifice)
	End Cap Kit (STD CHG) LH:SCR/RH:SCR		Check Valve Kit (0.031" Orifice)
	End Cap Kit (AUX CHG) LH:SCR/RH:Poppet		Check Valve Kit (0.044" Orifice)
	End Cap Kit (AUX CHG) LH:Poppet/RH:SCR		System Check / Relief Kit
	End Cap Kit (AUX CHG) LH:SCR/RHPoppet, Thru		System Check Relief Kit (.031" Orifice)
	End Cap Kit (AUX CHG) W/Poppets, Thru		Shock Valve Kit
	End Cap Kit (AUX CHG) W/SCR;s, Thru	44	Charge Relief Valve Kit (1/4" Plastic Ball & 50654 Spring)
	End Cap Kit (AUX CHG) LH:Poppet/RH:SCR, Thru		Charge Relief Valve Kit (9/16" SAE Plug & 3101536 Spring)
3	Straight Headless Pin	45	Aux Relief Valve Kit (1/4" Steel Ball)
4	Hex Flange Bolt M8-1.25 X 60 mm LG		Aux Relief Valve Kit (Aux Poppet)
5	Housing O-Ring	49	Trunnion Seal/Retainer Kit
6	Charge Pump Kit (STD)	54	Auxiliary Filter Kit
	Charge Pump Kit (STD CHG), Thru	55	Plate, Adapter (Gear A)
	Aux Pump Kit (AL., 15T Splined, 2-7/16 SAE Ports)	56	Straight Thread Plug
	Aux Pump Kit (AL., 15T Splined, 3-7/16 SAE Ports)	59	O-Ring
7	STD Gerotor Assy (.11 cu. In/rev D-Drive) Auxiliary Gerotor & Housing Assembly	64	Connector
8	O-Ring	66	5/16" SAE Plug
10	Socket Head Screw M6 x 1.0-20 mm Lg (STD CHg)	67	Filter Cover
	Hex Flange Bolt 8M-1.25 x 60 mm (Aux Chg)	69	Straight Headless Pin
	Cap Screw, Hex 5/16-18 x 1.00 (Thru Chg)	75	Shim - Charge Pump (.002 - Red)
	Supplied with item # 2 only	80	Pin, Straight Headless
15	Bypass Valve Kit (Blank)	85	R-Ring - 144
	Bypass Valve Kit (0.031")	90	Hub / 6" Fan Kit
	Bypass Valve Kit (0.043")		Hub / 7" CCW Fan Kit
18	Pump Shaft Kit (Blind 15mm Keyway W/Std Chg)		Hub / 7" CW Fan Kit
	Pump Shaft Kit (Blind 15mm Keyway W/Aux Chg)		Hug / 7" Fan Kit
	Pump Shaft Kit (9 Tooth W/Std Chg)	98	Return Arm
	Pump Shaft Kit (9 Tooth W/Aux Chg)	99	Inner Scissor Arm
	Pump Shaft Kit (15mm Keyed, Std Chg, Thru)	100	Seal Kit
	Pump Shaft Kit (9 Tooth Thru Chg)	101	Spacer RTN
	Pump Shaft Kit (Tapered)	102	Spring, Extension
19	Ball Bearing 17 X 40 X 12	103	Screw, 5/16 x .875 (patch)
20	Lip Seal 17 X 40 X 7 PTC	104	Washer .34 x .88 x .06
21	Spacer	105	Washer, Nylon
22	Retaining Ring	106	Bolt
25	Cylinder Block Kit	107	Nut, Hex Lock 5/16 - 24 UNF
29	Block Spring	110	Kit, RTN, STD
30	Block Thrust Washer		Kit, RTN, CW
32	Swashplate		Kit, RTN, CCW
		209	Shroud Bracket
		210	Shroud

REPAIR - PK SERIES PUMP

Repair - PK Series Pump	73-90
How to Use This Manual	73
General Instructions	73
Tools and Torques	74
Return to Neutral Linkage	75
Standard Control Arm Linkage	76
Fan Assembly	76
Input Shaft Seal	77
Trunnion Arm Seal	77
Check Valves	78
Shock Valves	78
Bypass	79
Charge Pump-Standard or Thru Shaft	80
Auxiliary Pump	81
End Cap	82
Cylinder Block	83
Block Spring and Thrust Bearings	84
Swashplate and Cradle Bearings	84
Input Shaft	85
Trunnion Arm	86
Parts List	88-89

HOW TO USE THIS MANUAL

Each assembly is provided with an exploded view showing the parts involved. **The item reference numbers in each illustration are for assembly instructions only.** See pages 88 and 89 for part names and descriptions. A complete exploded view and item list of the pump is provided at the end of this section.

GENERAL INSTRUCTIONS

Cleanliness is a primary means of ensuring satisfactory life on repaired pumps. Thoroughly clean all exposed surfaces prior to any type of maintenance. Cleaning of all parts by using a solvent wash and air drying is usually adequate. As with any precision equipment, all parts must be kept free of foreign material and chemicals.

Protect all exposed sealing surfaces and open cavities from damage and foreign material. The external surfaces should be cleaned before beginning any repairs.

Lip-type seals (shaft seals) are used on the input shaft and directional control shaft of each pump. These seals can be replaced without major disassembly of the unit. However, replacement of these seals generally requires removal of the pump from the machine. Upon removal, it is recommended that all seals, O-rings and gaskets be replaced.

During installation, lightly lubricate all seals, O-rings and gaskets with clean petroleum jelly prior to assembly. Also protect the inner diameter of the seals by covering the shaft with a cellophane (plastic wrap, etc.) material.

Parts requiring replacement must be replaced from the appropriate kits identified in the Items Listing, found at the end of this manual. Use only original Hydro-Gear replacement parts found listed in BLN-51427 (CD).

TOOLS AND TORQUES

Miscellaneous	3/8-Inch Drive Ratchet and Sockets
P Series Service & Repair Manual	7/16-inch Socket
Torque Wrench	1/2-inch Socket
Scribe, Paint Pen, or Marker	9/16-inch Socket
Seal Hook with a Magnet	5/8-inch Socket
Flat Blade Screwdriver	11/16-inch Socket
	10-mm Socket
Pliers	
Internal Snap Ring	Combination Wrenches
	7/16 inch
Allen Wrenches	1/2 inch
5mm	9/16 inch
1/8 inch	5/8 inch
3/16 inch	11/16 inch
1/4 inch	7/8 inch
	10 mm

Table 1. Required Tools

Item # and/or Description	Torque
Case Drain (fitting torque)	200-250 lb-in (22.6-28.2 Nm)
System Port (fitting torque)	370-470 lb-in (41.8-53.1 Nm)
Inlet (fitting torque)	200-250 lb-in (22.6-28.2 Nm)
4, End Cap/Adapter Plate Bolts	180-220 lb-in (20.3-24.9 Nm)
10, Cap Screw	180-220 lb-in (20.3-24.9 Nm)
15, Bypass Valve	110-130 lb-in (12.4-14.6 Nm)
42A, 42B, Shock Valves/Check Plugs	180-240 lb-in (20.3-27.1 Nm)
44, System Charge Relief Kit (Aux Chg)	180-240 lb-in (20.3-27.1 Nm)
45, Aux Relief Valve Kit	180-240 lb-in (20.3-27.1 Nm)
56, Diagnostic Plug	84-120 lb-in (9.4-13.5 Nm)
66, Filter Cover Plug	55-85 lb-in (6.2-9.6 Nm)
67, Filter Cover	200-275 lb-in (22.6-31.1 Nm)
103, Screw 5/16 x .875	200-240 lb-in (22.6-27.1 Nm)
106, Bolt	180-220 lb-in (20.3-24.9 Nm)

Table 2. PK Pump Torque Values

PK SERIES PUMP REPAIR

REMOVAL, INSPECTION AND/OR REPLACEMENT OF RETURN TO NEUTRAL ASSEMBLY

Refer to Figure 1.

Prior to disassembly, note the position of the scissor arm brackets and the tab on the outer control arm bracket.

Disassembly

CAUTION: The spring used on the return to neutral linkage is under tension. To avoid possible injury, use care and proper protection during disassembly and assembly of the return to neutral linkage.

1. Loosen (but do not remove) the bolt (106).
2. To relieve spring tension, carefully pry up on the outer scissor control arm until it releases from the tab on the outer control arm bracket.
3. Remove the spring (102), bolt(106) washer (104).
4. Remove the scissor arm (99).
5. Remove the outer control arm bracket(94), bolt (103), washer (104) and the inner return arm bracket(98).

Inspection

1. With the arm control linkage removed, inspect the trunnion arm (37) and trunnion arm seal (49).
2. Inspect scissor arm (99) and all other linkage parts for damage, corrosion or wear.

Assembly

1. Install the inner return arm bracket(98), washer (104) and bolt (103).

NOTE: Do not over tighten the bolt (103). The bracket must move freely.

2. Install the inner scissor control arm(94)
3. Tighten washer (104), and nut (103) to the correct torque value. See page 74.
4. Install the scissor arm(99).
5. Install washer(104) and bolt (106) to the correct torque value. See page 74.
5. Install the spring (102).

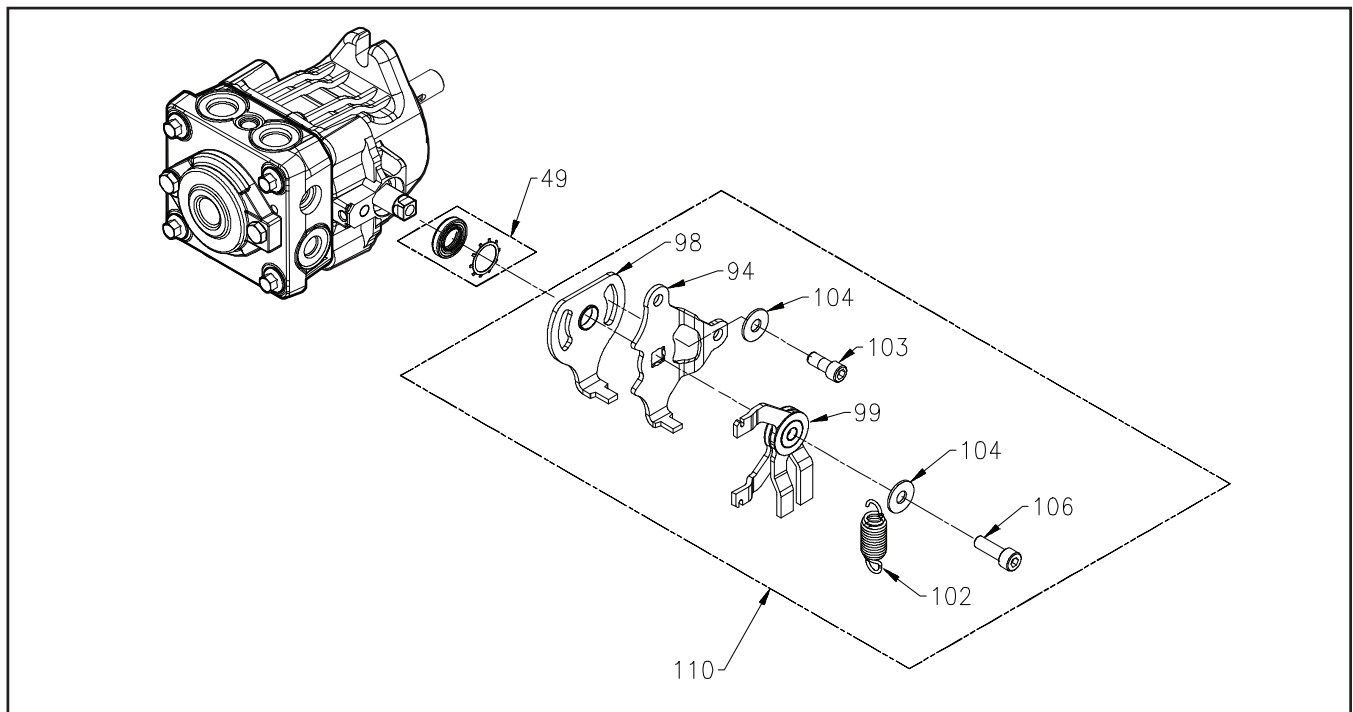

Figure 1. PK Pump Return to Neutral

REMOVAL, INSPECTION AND/OR REPLACEMENT OF CONTROL ARM

Refer to Figure 2.

Disassembly

1. Remove the bolt (106), washer (104) and bushing (101).
2. Remove the outer control arm bracket.
3. Remove bolt (103), washer (104) and the inner control arm bracket.

Inspection

1. With the arm control linkage removed, inspect the trunnion arm (37) and trunnion arm seal (49).
2. Inspect bushing (101) and all other linkage parts for damage, corrosion or wear.

Assembly

1. Install the inner control arm bracket, washer (104) and bolt (103).

NOTE: Do not over tighten the bolt (103). The bracket must move freely.

2. Install the outer control arm bracket, bushing (101), washer (104), and bolt (106). Tighten to the correct torque value. See page 74.

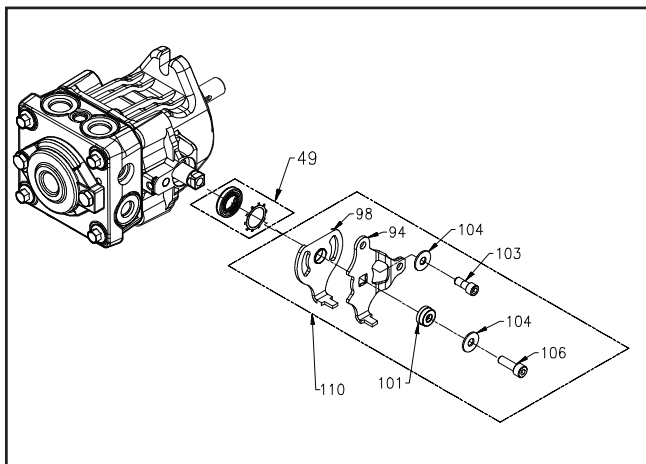

Figure 2. PK Pump Standard Control Arm

REMOVAL, INSPECTION AND/OR REPLACEMENT OF FAN ASSEMBLY

Refer to Figure 3.

Disassembly

1. Remove the fan shroud (210) from the mounting bracket (209) by carefully pushing down on the shroud tabs.
2. Remove the nut (106) and fan assembly (90).
3. Remove the bolts (10) and bracket (209).

Inspection

Inspect the fan shroud (210), fan assembly (90) and mounting bracket (209) for damage.

Assembly

1. To install the mounting bracket (209), align and insert the bolts (10) into the bracket and charge pump cover. While holding the charge cover in place, tighten the bolts (10) per table 2, page 74.
2. Install the fan and washer assembly onto the shaft.
3. Install the nut (106) and tighten per table 2, page 74.
4. Install the fan shroud (210) onto the mounting bracket (209). Make sure that all shroud lock tabs are fully engaged in the mounting bracket slots.

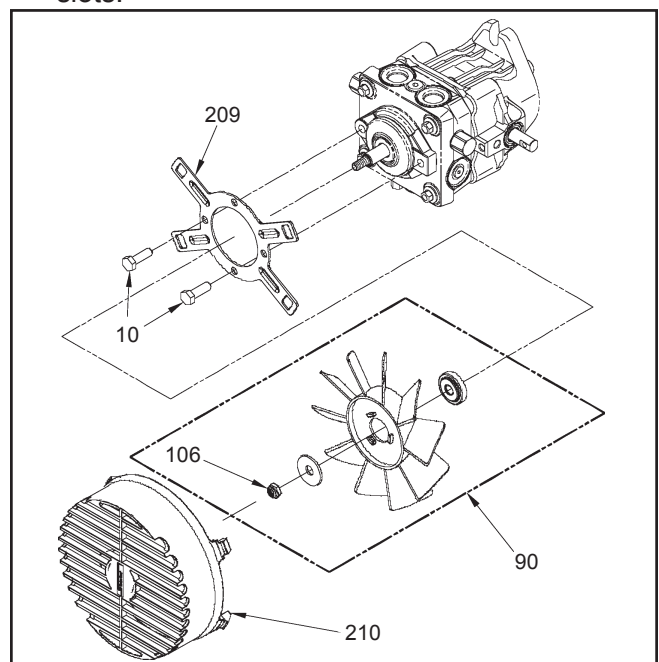

Figure 3. PK Pump Fan Assembly

REMOVAL, INSPECTION AND/OR REPLACEMENT OF INPUT SHAFT SEAL

Refer to Figure 4.

Disassembly

1. Remove retaining ring (22) from housing.
2. Remove lip seal (20). Care must be taken to prevent damage to the housing bore, shaft sealing surface, or bearing. Once removed, the seal is not reusable.

Inspection

With seal removed inspect the spacer (21) and housing (1) bore for damage, corrosion or wear.

Assembly

1. Lubricate the new lip seal (20) inside diameter with petroleum jelly.
2. Wrap the input shaft with plastic wrap to prevent damage to the inner surface of the lip seal (20).
3. Slide spacer (21) and seal (20) over the input shaft so that lettering on the seal faces out.
4. Press the lip seal (20) into the housing bore. Insure the lip seal (20), input shaft or housing (1) bore does not become damaged.
5. Install the retaining ring (22) into the housing bore groove.

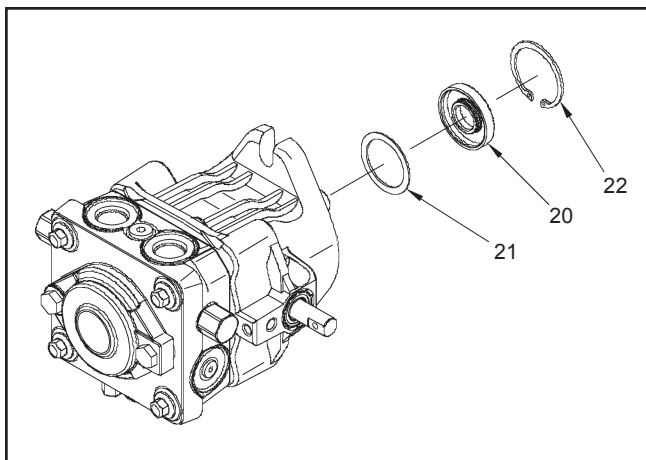

Figure 4. PK Pump Input Shaft Seal

REMOVAL, INSPECTION AND/OR REPLACEMENT OF TRUNNION ARM SEAL

Refer to Figure 5.

Disassembly

1. Remove the RTN assembly or control arm.
2. Remove the retainer and lip seal (49) from the housing. Care must be taken to prevent damage to the housing trunnion bore, trunnion arm and sealing surface. Once removed the retainer and lip seal are not reusable.

Inspection

With the lip seal (49) removed, inspect the area for corrosion and wear. Inspect the trunnion bore area sealing surface for damage or wear.

Assembly

1. Lubricate the new lip seal (49) inside diameter with petroleum jelly.
2. Wrap the trunnion arm with plastic wrap to prevent damage to the inner surface of the lip seal (49).
3. Slide the lip seal (49) over the trunnion arm so that the lettering on the seal (49) faces out.
4. Press the lip seal (49) into the housing bore. Insure the seal (49), trunnion arm, and housing bore do not become damaged. Remove the plastic wrap.
5. Install the retainer from (49) over the trunnion arm on top of the lip seal. Press into the trunnion seal bore in the housing until the retainer mates against the trunnion seal.
6. Install the RTN assembly or control arm.

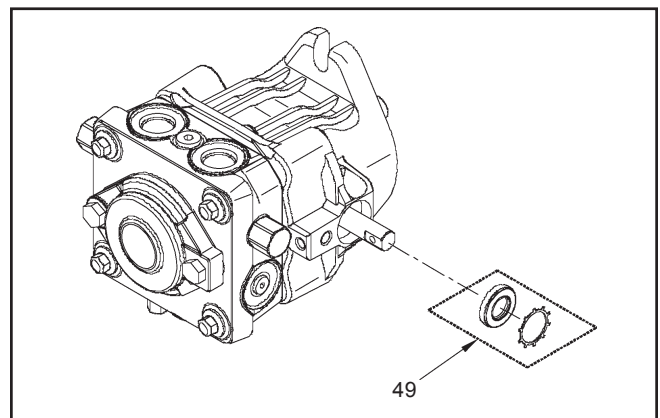

Figure 5. PK Pump Trunnion Arm Seal

REMOVAL, INSPECTION AND/OR REPLACEMENT OF CHECK VALVES

Refer to Figure 6.

Perform disassembly, inspection and assembly on check valves one side at a time. Some units vary in "A" side to "B" side check configuration.

Disassembly

1. Remove the check valve (42) with an 1/4" allen wrench.
2. Remove the valve spring and poppet from the end cap.

Inspection

1. Inspect the poppets and mating seats in the end cap for damage or foreign material.

Assembly

1. Lay the pump on its side, so the check plug port is horizontal.
2. Insert the check plug, spring and poppet (42) as one assembly into the check plug port. Tighten, reference Table 2, page 74 for torque values.
3. Repeat disassembly, inspection and assembly for the opposite port side.

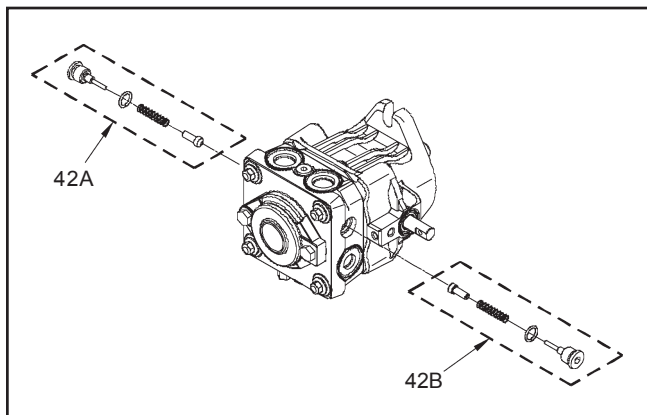

Figure 6. PK Pump Check Valves

REMOVAL, INSPECTION AND/OR REPLACEMENT OF SYSTEM CHECK RELIEFS (SCR'S) OR SHOCK VALVES

Refer to Figure 7.

Disassembly

Perform disassembly, inspection and assembly on SCR/shock valve one side at a time. Some units vary in "A" side to "B" side configuration.

1. Remove the SCR (42) with a 7/8" wrench or the shock valve (42) with an 11/16" wrench.
2. Remove the check relief/shock valve spring and the check relief/shock valve from the end cap.

Inspection

1. Inspect the check relief or shock valve (42) and mating seat in the end cap for damage or foreign material.

Assembly

1. Lay the pump on its side, so the check plug port is horizontal.
2. Insert the system check relief spring and check relief or shock valve spring and shock valve as one assembly into the check plug port. Tighten to the correct torque value. See page 74.
3. Repeat disassembly, inspection and assembly for the opposite port side.

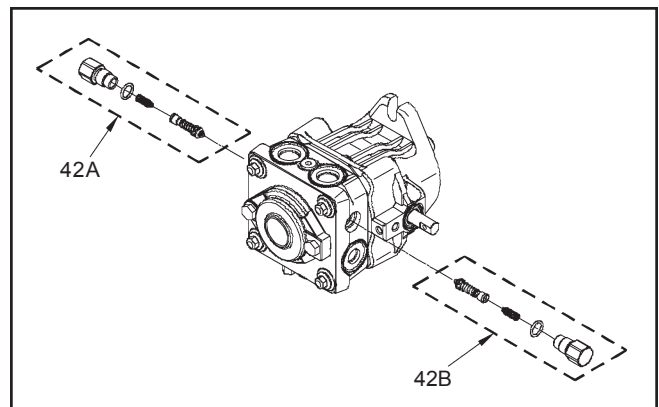

Figure 7. PK Pump Shock Valves

REMOVAL, INSPECTION AND /OR REPLACEMENT OF THE BYPASS

Refer to Figure 8.

Disassembly

1. Loosen the bypass valve (15) using a 5/8" wrench.
2. Remove the bypass (15) from the end cap (2).

Inspection

1. Inspect the bypass O-rings and mating seats in the end cap (2) for damage or foreign materials.
2. If damaged or worn replace bypass (15)

Assembly

1. Lay the pump on its side, so the bypass port is horizontal.
2. Insert the bypass (15) into the bypass port on the end cap (2). Tighten to the proper torque value. See page 74.

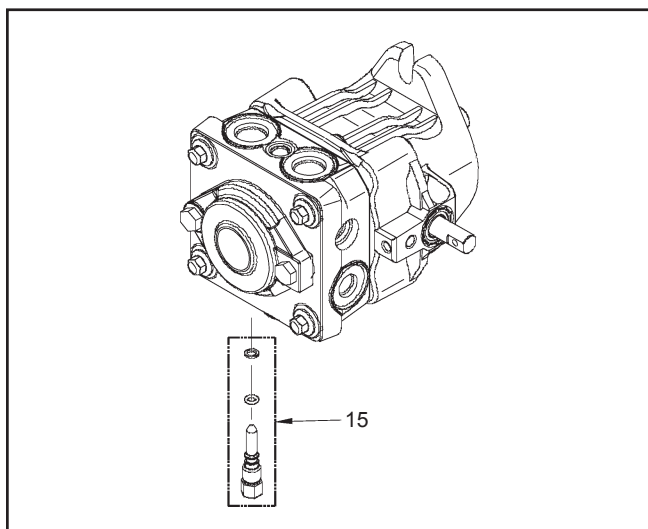

Figure 8. PK Pump Bypass

REMOVAL, INSPECTION AND ASSEMBLY OF STANDARD OR THRU SHAFT CHARGE PUMP

Refer to Figure 9.

Disassembly

1. Prior to removal of the charge pump cover, place a mark on the cover and end cap for alignment at assembly.
2. Using a 1/2 inch wrench, or 5 mm allen wrench, loosen the charge pump cover bolts (10) from the end cap (2). While holding the charge cover in place, remove the charge cover bolts (10).
3. Remove the charge cover, O-ring and gerotor items (6). Carefully check for and remove the charge spring and charge ball (44).
4. For the Thru Shaft charge pump, remove the shaft seal.

Inspection

1. Inspect the charge cover O-ring and running surfaces for damage. Inspect the spring, check ball (44), and mating seat in the end cap (2) for damage or foreign material.

NOTE: If the end cap (2) is to be removed from the housing, do not assemble the charge pump (6) until the end cap is installed on the housing.

2. Inspect the charge cover bore for damage, corrosion or wear.

Assembly

NOTE: For the Thru Shaft charge pump follow steps 1-8. For the Standard charge pump follow steps 3-8.

1. Lubricate the new shaft seal with petroleum jelly.
2. Press the shaft seal into the charge cover. Be careful not to damage the seal or charge cover bore.
3. Position the pump with the input shaft down, and the end cap (2) horizontal. Place the charge ball (44) in the end cap (2) charge passage so the ball mates to the end cap (2) charge ball seat. Place the charge spring, on top of the charge ball.
4. Insert the inner gerotor over input shaft (18).
5. Align the outer gerotor to fit over the inner gerotor.
6. Insert the O-ring (8) into the groove in the charge cover.
7. Position the charge cover and O-ring with the aligning mark on the end cap. Place the charge cover and O-ring with aligning mark on the end cap. Place the charge cover and O-ring as one piece over the charge spring and gerotor assembly. Insure the spring fits into the charge cover spring retaining groove.
8. Align and insert the charge pump cover bolts (10) into the end cap (2). Tighten to the correct torque value. See Table 2, page 74. (Torque Values.)

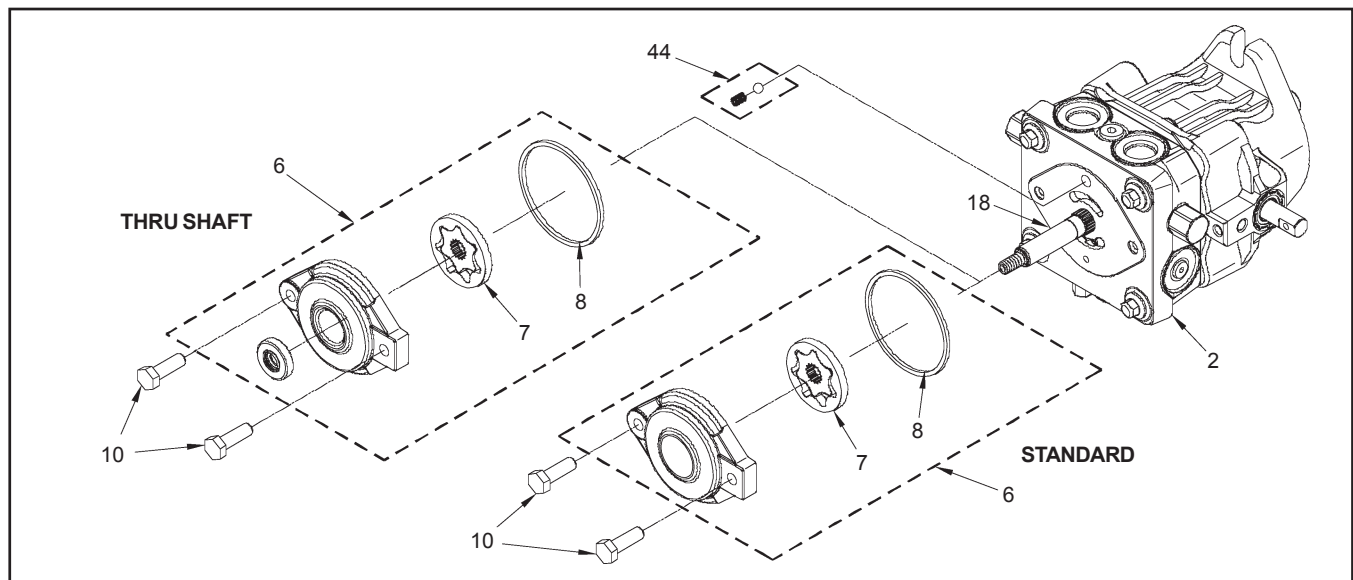

Figure 9. PK Pump Standard or Thru Shaft Charge Pump

REMOVAL, INSPECTION AND/OR REPLACEMENT OF AUXILIARY PUMP (IF EQUIPPED)

Refer to Figure 10.

Disassembly

1. Prior to removal of the auxiliary pump, place a mark on the auxiliary pump, charge pump (7) and end cap (2) for alignment at assembly.
2. Use a 10mm wrench to loosen the auxiliary pump bolts (10) from the end cap (2). While holding the auxiliary pump in place, remove the bolts (10).
3. Remove the auxiliary pump, gasket (75), O-ring (8) and charge pump (7). While removing the charge pump, be sure to retain the spring and ball (44A) housed in the end cap (2).
4. Remove the plug (66) from the filter cover (67).
5. Use a 7/8 inch wrench to remove the filter cover assembly (67) from the auxiliary pump.
6. Remove the O-ring and filter (54).
7. Remove the charge relief valve assembly (44) and auxiliary relief valve assembly (45) from the auxiliary pump.

Inspection

1. With the auxiliary pump removed, inspect the pump running surfaces for wear or damage.
2. Inspect all O-rings, gasket and mounting seats.

3. Inspect the filter cover assembly threads and filter for wear, damage or foreign material.

Assembly

1. Install the check ball, spring, and cap as one assembly (45) into the auxiliary relief valve port. Tighten to the correct torque value. See page 74.
2. Install the poppet, spring and cap (44) as one assembly into the charge relief port. Tighten to the correct torque value. See page 74.
3. Install the filter (54) and O-ring onto the filter cover assembly (67). Install the assembly (67) into the auxiliary pump and tighten. Install plug (66) into the filter cover (67).
4. Lay the PJ Pump (input shaft down), so the end cap is horizontal. Install the O-ring (8) into the charge pump (7).
5. Install the gasket (75) onto the auxiliary pump.
6. Make sure that the ball and spring (44A) are seated in the end cap (2), then position the auxiliary pump and gasket with the aligning mark on the charge pump (7). Insure that the pump fully engages the alignment pins (69).
7. Align and insert the bolts (10) into the auxiliary pump. While holding the auxiliary pump and charge pump in place, tighten the bolts (10) per table 2, page 74.

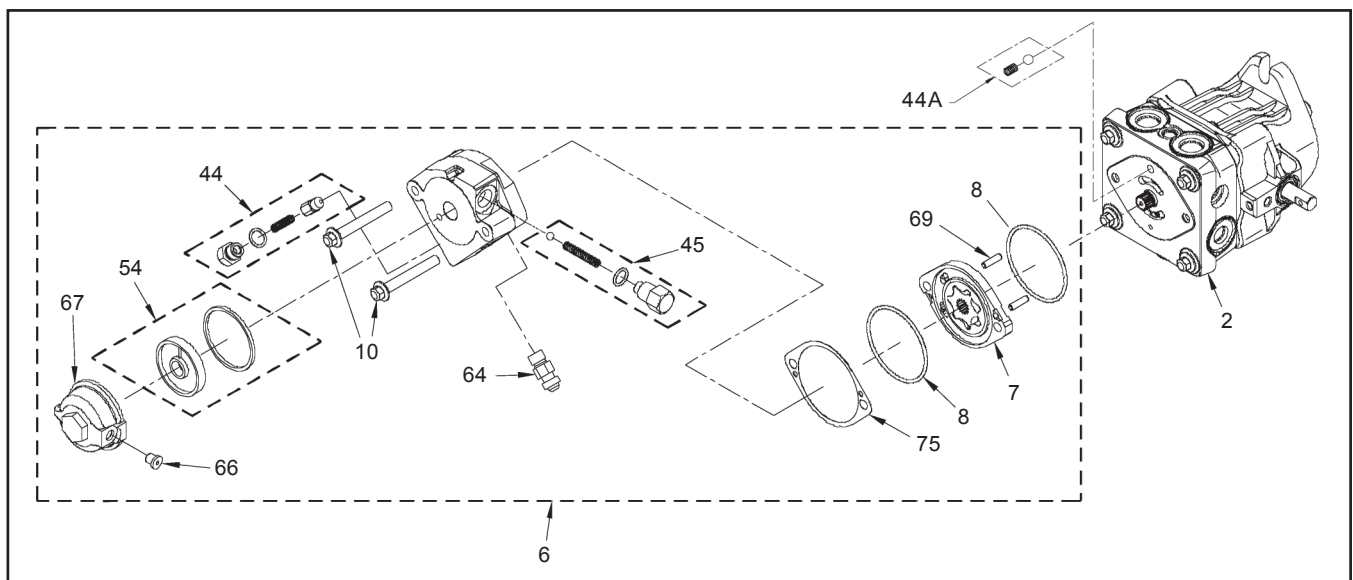

Figure 10. Auxiliary Pump

REMOVAL, INSPECTION AND ASSEMBLY OF THE END CAP

Refer to Figure 11.

Disassembly

1. Remove charge pump. (See page 62).
2. Using a 10 mm wrench, loosen the end cap bolts (4) evenly.
3. Hold the end cap (2) in place and remove the four end cap bolts (4).
4. Slowly remove the end cap (2).
5. Remove housing gasket (5).

Inspection

1. Inspect the end cap (2) body for damage, nicks or unusual wear patterns. Replace if necessary.
2. Inspect the running surface (side that contacts the cylinder block) of the end cap (2). The running surface may show evidence of minor abrasive rings, this is normal.

Grooving in the end cap, or material transfer that is evident when the surface is checked by dragging a fingernail across it, would be cause for replacement of the end cap (2).

3. Replace the housing gasket (5) with a new gasket before assembly.

Assembly

1. Install housing gasket (5) into gasket seat of housing (1).
2. Lubricate the cylinder block (25) to end cap (2) mating surface with clean oil prior to installation.
3. Install end cap (2). Before installing the four end cap bolts (4), push down on end cap (92) verifying alignment and insuring that the cylinder block pistons spring back and forth. Install end cap bolts (4). Tighten to the correct torque value. See Table 2, page 74 (Torque Values).
4. Install the charge pump. (See page 80.)

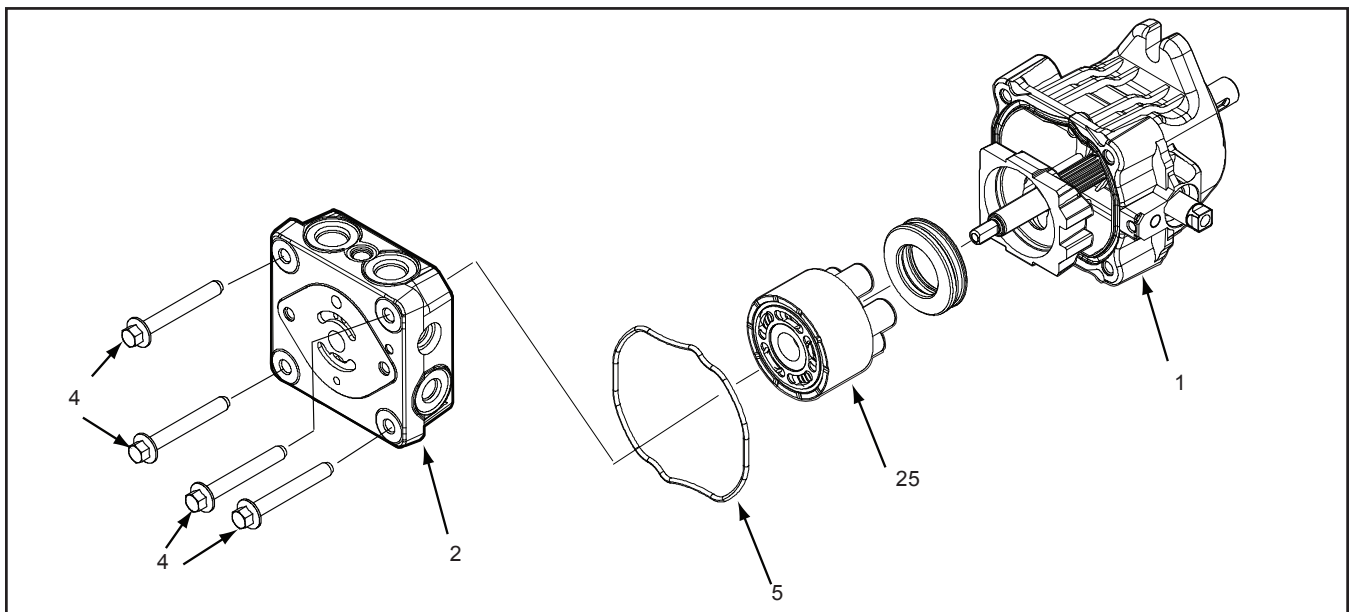

Figure 11. PK Pump End Cap

REMOVAL, INSPECTION AND ASSEMBLY OF THE CYLINDER BLOCK

Refer to Figure 12.

Disassembly

1. Remove charge pump. (See page 80).
2. Remove end cap. (See page 82).
3. Tilt the pump on its side and drain remaining oil. Lift out the cylinder block assembly (25).
4. Remove the pistons, springs and piston seats.

Inspection

1. Inspect the running surface of the cylinder block and piston ends for damage, nicks or unusual wear patterns. The running surface may show evidence of minor abrasion. This will be normal wear. If grooved or smeared, replace with a new cylinder block assembly.
2. Inspect the piston springs for distortion or breaks. If necessary, replace with a new cylinder block kit.
3. Inspect the piston seats. Residual oil may cause these to remain stuck to the inside of the pistons.

Assembly

1. Apply a thin layer of clean oil to the pistons and springs.

2. Install piston seats into the end of the pistons.
3. Install springs into the pistons.
4. Install each piston, spring and seat assembly into the cylinder block.
5. With the pump housing tilted on its side, install the cylinder block assembly (25) with pistons contacting the thrust bearing.

NOTE: To check if the cylinder block assembly is installed correctly, position the pump housing vertically and support housing at the mounting flange. Push down on the cylinder block. The cylinder block must move up and down freely. If it does not, remove the cylinder block assembly. Place a rubber band around the cylinder block pistons to hold them in position during installation. Then after installation cut the rubber band and remove it. Check cylinder block assembly for spring action.

6. Install the end cap. (See page 82)
7. Install the charge pump. (See page 80)

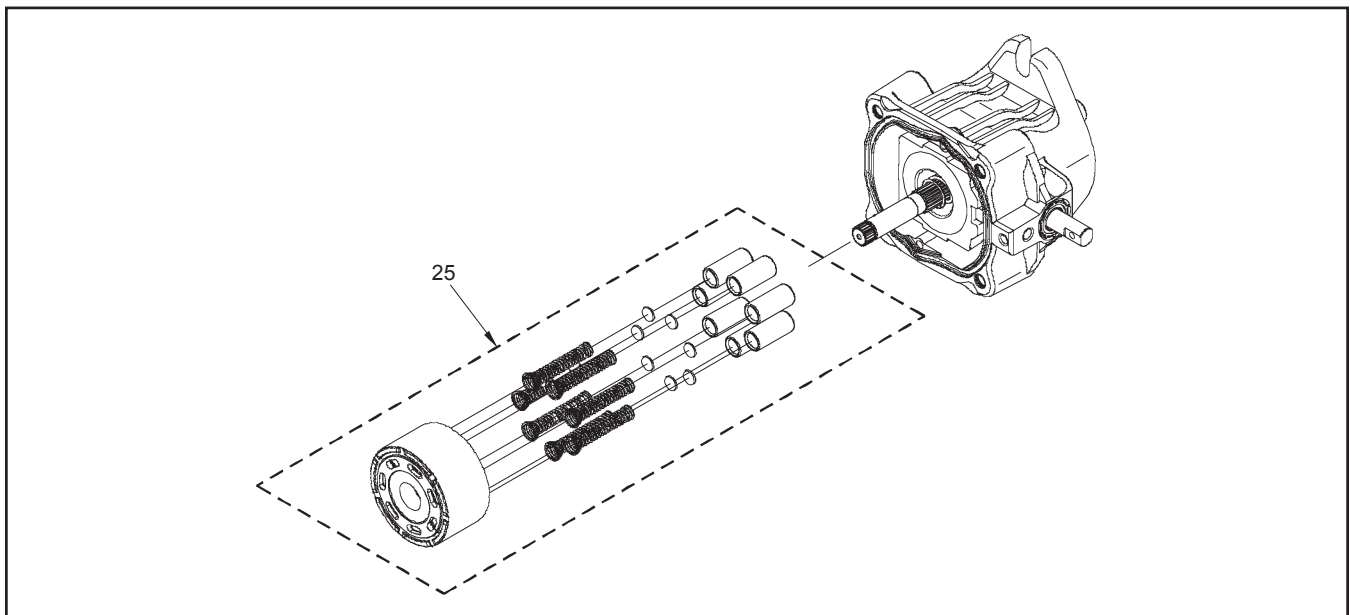

Figure 12. PK Pump Cylinder Block

REMOVAL, INSPECTION AND ASSEMBLY OF BLOCK SPRING AND THRUST BEARING

Refer to Figure 13.

Disassembly

1. Remove the block spring (29).
2. Remove the block thrust washer (30) and thrust bearing (34).

Inspection

1. Inspect and replace the block spring (29) if it is distorted or broken.
2. Inspect the running surface of the bearing races for damage, nicks or unusual wear patterns. The running surface may show evidence of minor abrasion. This will be normal wear.

Inspect the bearings for free movement. Inspect the bearing cage for distortion or damage. Replace if necessary.

Assembly

1. Install thrust bearing and race assembly (34).
2. Install the block thrust washer (30).

NOTE: The difference in race thicknesses: The thin race seats into the swashplate (32). The thicker race will be installed toward the piston noses.

3. Install block spring (29).

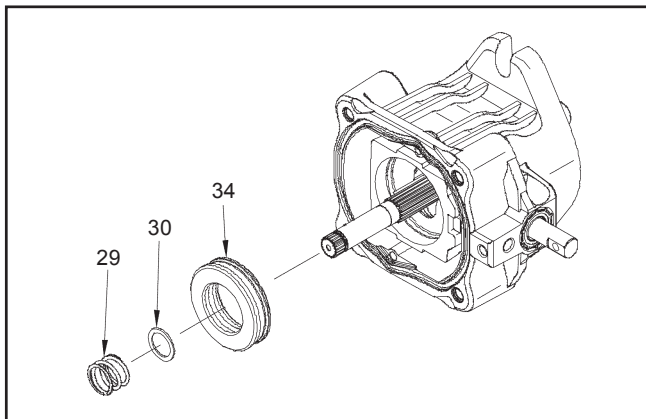

Figure 13. Pump Block Spring and Thrust Bearing

REMOVAL, INSPECTION AND ASSEMBLY OF SWASHPLATE AND CRADLE BEARINGS

Refer to Figure 14.

Disassembly

1. Remove the swashplate (32).

Inspection

1. Inspect the running surface of the bearing pocket of swashplate (32) for damage, nicks or unusual wear patterns. The running surface may show evidence of minor abrasion. This is normal wear. Inspect the cradle bearing side of the swashplate (32) for damage. Replace if necessary.
2. Inspect the cradle bearings attached to the inside of the housing (1) for normal wear patterns and placement, and insure they are staked securely in place. If the bearings are damaged, replace housing (1).

NOTE: The cradle bearings will have discoloration due to normal wear. Under normal circumstances, this will not warrant replacement.

Assembly

1. Install swashplate (32) by holding trunnion arm's slot guide (38) with a flat tip screwdriver. Use the screwdriver to hold the slot guide in place while positioning the swashplate (32) onto the cradle bearing in the housing (1).
2. Rotate trunnion arm (37) to verify that the swashplate moves freely.

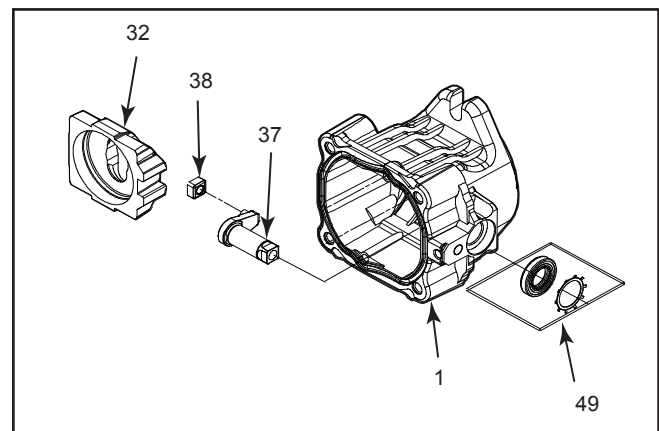

Figure 14. PK Pump Swashplate and Cradle Bearings

REMOVAL, INSPECTION AND ASSEMBLY OF INPUT SHAFT

Refer to Figure 15.

Disassembly

1. Remove the retaining ring (22).
2. Remove the lip seal (20).
3. Remove the spacer (21).
4. Remove the shaft (18) and bearing (19) assembly from the pump.

Inspection

1. Inspect the input shaft (18) for worn splines, surface damage, or keyway damage. Replace shaft assembly if necessary.
2. Inspect the bearing (19) for evidence of scoring, corrosion, or damage. If the bearing must be replaced, remove the retaining ring and use a press or bearing puller to remove the bearing.
3. Inspect and replace the spacer (21) if it is bent or broken.
4. Inspect and replace the retaining ring (22) if it is bent or broken.

NOTE: Upon removal, all seals, O-rings and gaskets should be replaced.

Assembly

NOTE: If trunnion arm is to be removed, do not assemble input shaft until the trunnion arm is installed.

NOTE: During installation, lightly lubricate all seals, O-rings and gaskets with clean petroleum jelly prior to assembly. Also, protect the inner diameter of seals by covering the shaft with plastic wrap.

1. If removed, press bearing (19) onto shaft (18) tight against the shoulder of the shaft. Install retaining ring onto the shaft (18).
2. Install input shaft assembly (18) into the housing (1) bore. Light tapping with a rubber mallet may be necessary on the input shaft (18) once the bearing is aligned with the housing (1) bore. Verify that the shaft rotates smoothly.
3. Install spacer (21).
4. Install new lip seal (20) with the flat side of the seal toward the outside of the pump.
5. Remove the plastic wrap.
6. Install retaining ring (22).

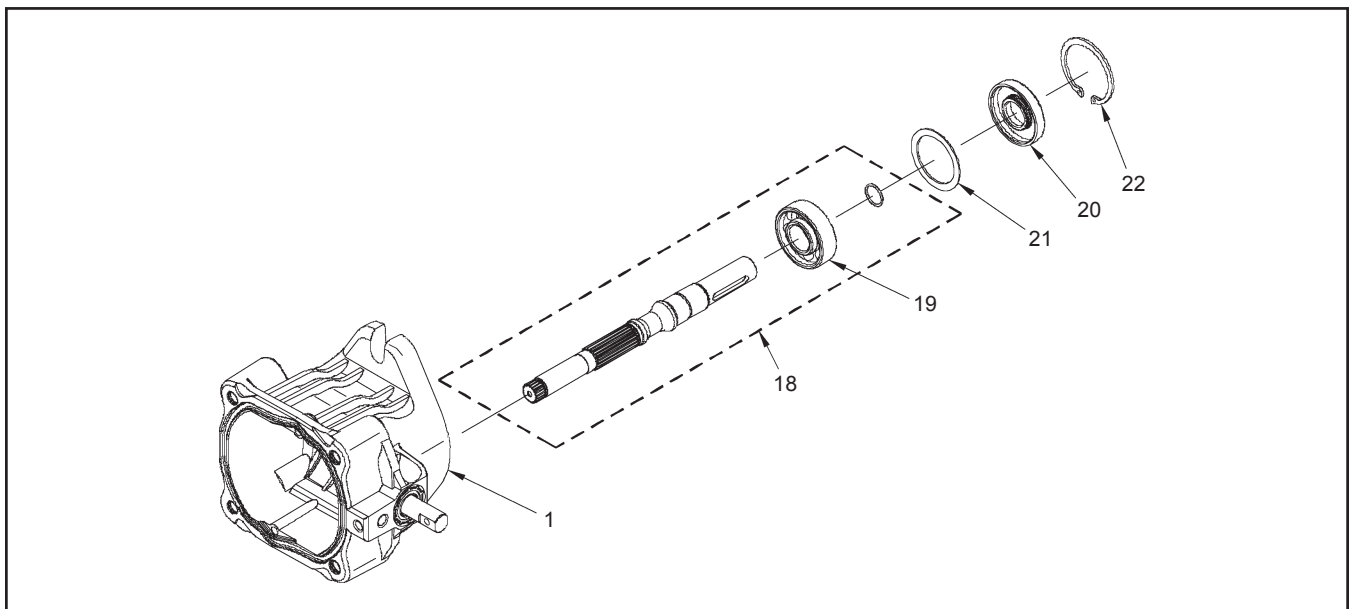

Figure 15. PK Pump Input Shaft

REMOVAL, INSPECTION AND INSTALLATION OF TRUNNION ARM

Refer to Figure 16.

Disassembly

1. Remove the slot guide (38).
2. Remove and discard the trunnion seal retainer and seal (49).
3. Remove the trunnion arm (37).

Inspection

1. Inspect the trunnion arm (37) for wear or damage. Replace the trunnion arm if necessary.
2. Check for excessive play between trunnion arm (37) and housing (1). Replace housing if necessary.

Assembly

1. Install the trunnion arm (37) into the housing (1) bore. Rotate the trunnion arm to verify free movement.
2. Install a new seal and seal retainer (49).
3. Install slot guide (38).
4. To completely assembly the pump, refer to the assembly steps on pages 75-86. Begin with the trunnion arm assembly steps listed on page 86 and complete the assembly steps in reverse order working toward the front of the manual.

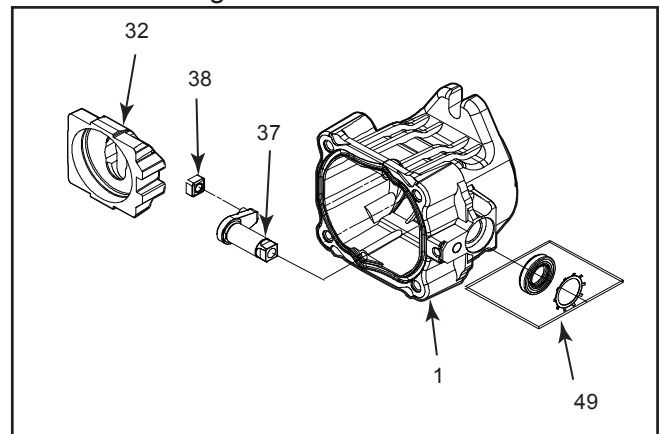
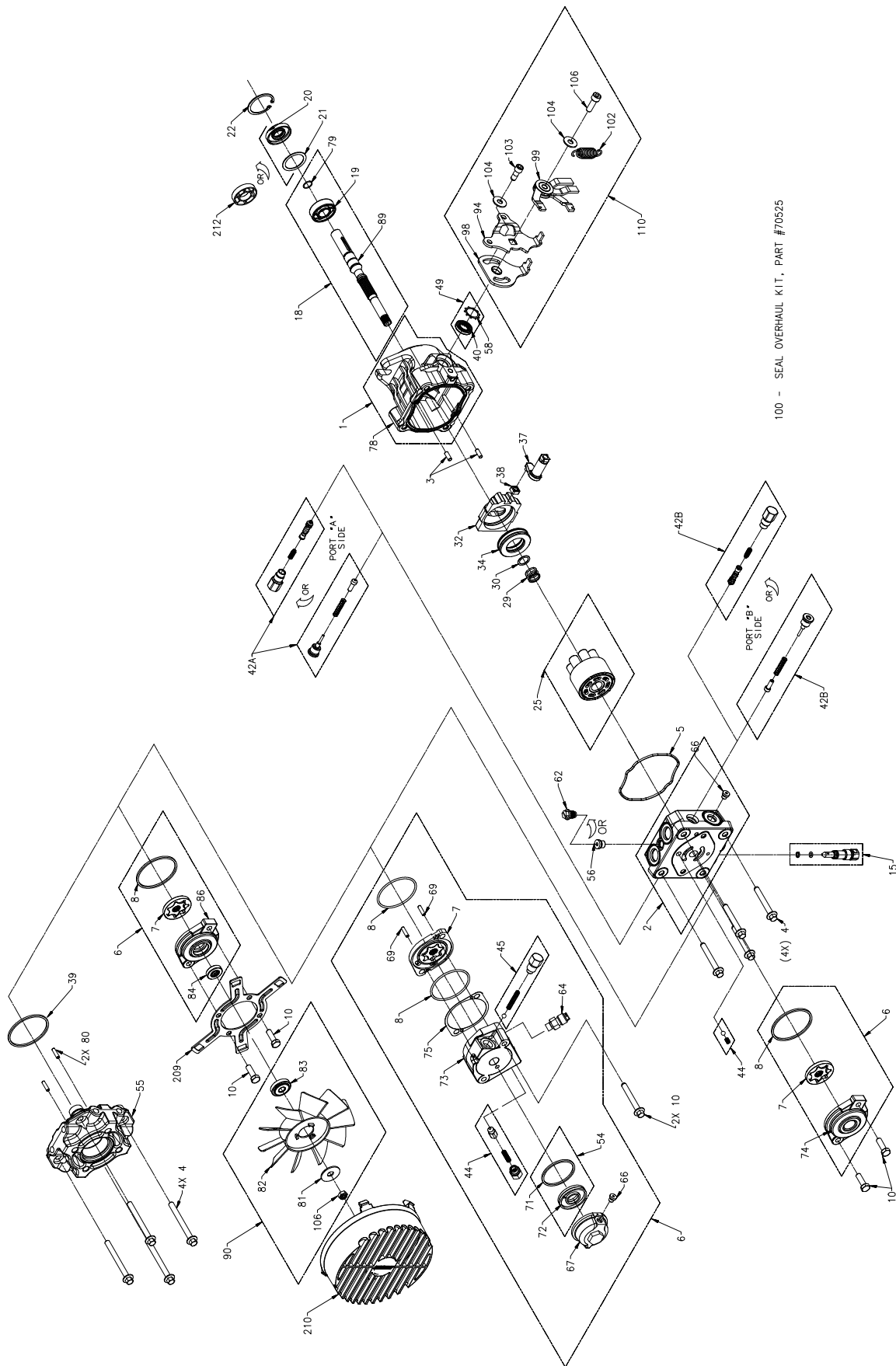

Figure 16. PK Pump Trunnion Arm



100 - SEAL OVERHAUL KIT, PART #70525

BOXES INDICATE ITEMS INCLUDED IN KITS.

Kit Number

Figure 17. PK Pump

ITEM LIST - PK SERIES

Part numbers are not provided in this manual. See website for part numbers.

No.	Description	No.	Description
1	Housing Kit	34	Ball Thrust Bearing
2	End Cap Kit (W/Poppets, Standard Charge)	35	Stud, Torque
	End Cap Kit (W/ SCR'S, Standard Charge)	37	Trunnion Arm
	End Cap Kit (W/ Poppets, Auxiliary Charge)		Trunnion, RTN
	End Cap Kit (W/ SCR'S, Auxiliary Charge)	38	Slot Guide
	End Cap Kit (STD CHG) LH;SCR/HR: Poppet	42	Check Valve Kit (blank Orifice)
	End Cap Kit (STD CHG) LH:Poppet/RH:SCR		Check Valve Kit (0.024" Orifice)
	End Cap Kit (STD CHG) LH:SCR/RH:SCR		Check Valve Kit (0.031" Orifice)
	End Cap Kit (AUX CHG) LH:SCR/RH:Poppet		Check Valve Kit (0.044" Orifice)
	End Cap Kit (AUX CHG) LH:Poppet/RH:SCR		System Check / Relief Kit
	End Cap Kit (AUX CHG) LH:SCR/RHPoppet, Thru		System Check Relief Kit (.031" Orifice)
	End Cap Kit (AUX CHG) W/Poppets, Thru		Shock Valve Kit
	End Cap Kit (AUX CHG) W/SCR;s, Thru	44	Charge Relief Valve Kit (1/4" Plastic Ball & 50654 Spring)
	End Cap Kit (AUX CHG) LH:Poppet/RH:SCR, Thru		Charge Relief Valve Kit (9/16" SAE Plug & 3101536 Spring)
3	Straight Headless Pin	45	Aux Relief Valve Kit (1/4" Steel Ball)
4	Hex Flange Bolt M8-1.25 X 60 mm LG		Aux Relief Valve Kit (Aux Poppet)
5	Housing O-Ring	49	Trunnion Seal/Retainer Kit
6	Charge Pump Kit (STD)	54	Auxiliary Filter Kit
	Charge Pump Kit (STD CHG), Thru	55	Plate, Adapter (Gear A)
	Aux Pump Kit (AL., 15T Splined, 2-7/16 SAE Ports)	56	Straight Thread Plug
	Aux Pump Kit (AL., 15T Splined, 3-7/16 SAE Ports)	59	O-Ring
7	STD Gerotor Assy (.11 cu. In/rev D-Drive)	64	Connector
	Auxiliary Gerotor & Housing Assembly	66	5/16" SAE Plug
8	O-Ring	67	Filter Cover
10	Socket Head Screw M6 x 1.0-20 mm Lg (STD CHg)	69	Straight Headless Pin
	Hex Flange Bolt 8M-1.25 x 60 mm (Aux Chg)	75	Shim - Charge Pump (.002 - Red)
	Cap Screw, Hex 5/16-18 x 1.00 (Thru Chg)	80	Pin, Straight Headless
	Supplied with item # 2 only	85	R-Ring - 144
15	Bypass Valve Kit (Blank)	90	Hub / 6" Fan Kit
	Bypass Valve Kit (0.031")		Hub / 7" CCW Fan Kit
	Bypass Valve Kit (0.043")		Hub / 7" CW Fan Kit
18	Pump Shaft Kit (Blind 15mm Keyway W/Std Chg)		Hug / 7" Fan Kit
	Pump Shaft Kit (Blind 15mm Keyway W/Aux Chg)	98	Return Arm
	Pump Shaft Kit (9 Tooth W/Std Chg)	99	Scissor Arm
	Pump Shaft Kit (9 Tooth W/Aux Chg)	100	Seal Kit
	Pump Shaft Kit (15mm Keyed, Std Chg, Thru)	101	Spacer RTN
	Pump Shaft Kit (9 Tooth Thru Chg)	102	Spring, Extension
	Pump Shaft Kit (Tapered)	103	Screw, 5/16 x .875 (patch)
19	Ball Bearing 17 X 40 X 12	104	Washer .34 x .88 x .06
20	Lip Seal 17 X 40 X 7 PTC	105	Washer, Nylon
21	Spacer	106	Bolt
22	Retaining Ring	110	Kit, RTN, STD
25	Cylinder Block Kit		Kit, RTN, CW
29	Block Spring		Kit, RTN, CCW
30	Block Thrust Washer	209	Shroud Bracket
32	Swashplate	210	Shroud

REPAIR - PR SERIES PUMP

Repair - PR Series Pump	91-108
How to Use This Manual.....	91
General Instructions	91
Tools and Torques	92
Return to Neutral Linkage.....	93
Standard Control Arm Linkage	94
Fan Assembly	94
Input Shaft Seal	95
Trunnion Arm Seal	95
Check Valves	96
Shock Valves	96
Bypass.....	97
Charge Pump-Standard or Thru Shaft.....	98
Auxiliary Pump.....	99
End Cap.....	100
Cylinder Block.....	101
Block Spring and Thrust Bearings	102
Swashplate and Cradle Bearings	102
Input Shaft	103
Trunnion Arm	104
Parts List.....	106-107

HOW TO USE THIS MANUAL

Each assembly is provided with an exploded view showing the parts involved. **The item reference numbers in each illustration are for assembly instructions only.** See pages 106 and 107 for part names and descriptions. A complete exploded view and item list of the pump is provided at the end of this section.

GENERAL INSTRUCTIONS

Cleanliness is a primary means of ensuring satisfactory life on repaired pumps. Thoroughly clean all exposed surfaces prior to any type of maintenance. Cleaning of all parts by using a solvent wash and air drying is usually adequate. As with any precision equipment, all parts must be kept free of foreign material and chemicals.

Protect all exposed sealing surfaces and open cavities from damage and foreign material. The external surfaces should be cleaned before beginning any repairs.

Lip-type seals (shaft seals) are used on the input shaft and directional control shaft of each pump. These seals can be replaced without major disassembly of the unit. However, replacement of these seals generally requires removal of the pump from the machine. Upon removal, it is recommended that all seals, O-rings and gaskets be replaced.

During installation, lightly lubricate all seals, O-rings and gaskets with clean petroleum jelly prior to assembly. Also protect the inner diameter of the seals by covering the shaft with a cellophane (plastic wrap, etc.) material.

Parts requiring replacement must be replaced from the appropriate kits identified in the Items Listing, found at the end of this manual. Use only original Hydro-Gear replacement parts found listed in BLN-51427 (CD).

TOOLS AND TORQUES

Miscellaneous	3/8-Inch Drive Ratchet and Sockets
P Series Service & Repair Manual	1/2-inch Socket
Torque Wrench	9/16-inch Socket
Scribe, Paint Pen, or Marker	5/8-inch Socket
Seal Hook with a Magnet	10-mm Socket
Flat Blade Screwdriver	
	Combination Wrenches
Pliers	1/2 inch
Internal Snap Ring	9/16 inch
	5/8 inch
Allen Wrenches	7/8 inch
5mm	10 mm
3/16 inch	
1/4 inch	

Table 1. Required Tools

Item # and/or Description	Torque
Case Drain (fitting torque)	200-250 lb-in (22.6-28.2 Nm)
System Port (fitting torque)	370-470 lb-in (41.8-53.1 Nm)
Inlet (fitting torque)	200-250 lb-in (22.6-28.2 Nm)
Fan Nut, Hex Lock 5/16-24 UNF	160-220 lb-in (18.1-24.9 Nm)
42A, 42B, Shock Valves/Check Plugs	180-240 lb-in (20.3-27.1 Nm)
45, Aux Relief Valve Kit	180-240 lb-in (20.3-27.1 Nm)
49, Aux Bypass/Check Kit	180-240 lb-in (20.3-27.1 Nm)
50, Bypass Valve	110-130 lb-in (12.4-14.7 Nm)
56, Screw	180-220 lb-in (20.3-24.9 Nm)
58, Hex Screw	255-300 lb-in (28.8-33.9 Nm)
67, Filter Cover	200-275 lb-in (22.6-31.1 Nm)
102, Cap Screw, Socket Head M8 x 1.25 x 25	180-220 lb-in (20.3-24.9 Nm)
107, Screw, 5/16-24 x .75	200-240 lb-in (22.6-27.1 Nm)
151, Diagnostic Plug	85-120 lb-in (9.6-13.5 Nm)
156, Filter Cover Plug	55-85 lb-in (6.2-9.6 Nm)

Table 2. PR Pump Torque Values

PR SERIES PUMP REPAIR

REMOVAL, INSPECTION AND/OR REPLACEMENT OF RETURN TO NEUTRAL ASSEMBLY

Prior to disassembly, note the position of the scissor arm brackets and the tab on the outer control arm bracket.

See Figure 1.

Disassembly

CAUTION: The spring used on the return to neutral linkage is under tension. To avoid possible injury, use care and proper protection during disassembly and assembly of the return to neutral linkage.

1. Loosen (but do not remove) the bolt (102).
2. To relieve spring tension, carefully pry up on the outer scissor control arm until it releases from the tab on the outer control arm bracket.
3. Remove the spring (108), bolt (102), washer (99) and outer scissor arm bracket (103).
4. Remove bushing (106), washers (109), and the inner scissor arm bracket (104).
5. Remove the outer control arm bracket (101), bolt (107), washer (99), and inner control arm bracket (105).

Inspection

1. With the arm control linkage removed, inspect the trunnion arm (13) and trunnion arm seal (12).
2. Inspect bushing (106) and all other linkage parts for damage, corrosion or wear.

Assembly

1. Install the inner return arm bracket (105), washer (99) and bolt (107).

NOTE: Do not over tighten the bolt (107). The bracket must move freely.

2. Install the outer control arm bracket (101), washer (109) and bushing (106).
3. Install the inner scissor control arm bracket (104), washer (109), and outer scissor control arm bracket (103).
4. Install washer (99), and bolt (102). Tighten to the correct torque value. See page 92
5. Install the spring (108).

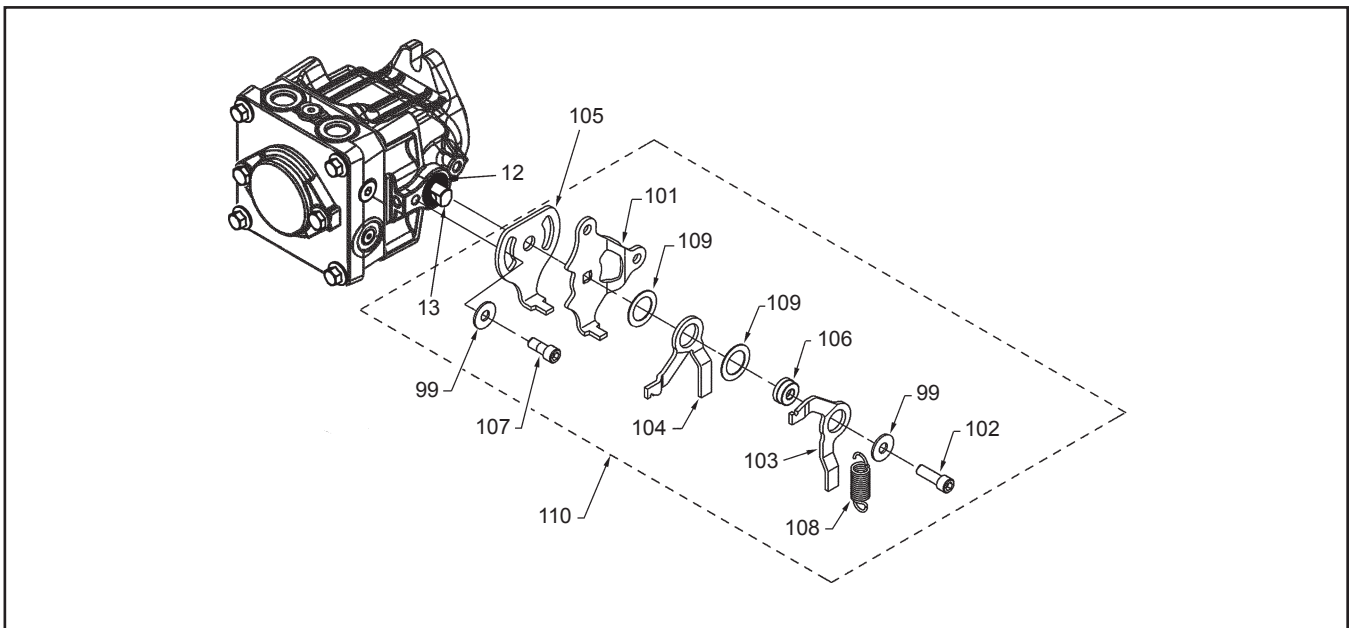

Figure 1. PR Pump Return to Neutral

REMOVAL, INSPECTION AND/OR REPLACEMENT OF CONTROL ARM

Refer to Figure 2.

Disassembly

1. Remove the bolt (102), washer (99) and bushing (106).
2. Remove the outer control arm bracket (101).
3. Remove bolt (107), washer (99) and the inner control arm bracket (105).

Inspection

1. With the arm control linkage removed, inspect the trunnion arm (13) and trunnion arm seal (12).
2. Inspect bushing (106) and all other linkage parts for damage, corrosion or wear.

Assembly

1. Install the inner return arm bracket (105), washer (99) and bolt (107).

NOTE: Do not over tighten the bolt (107). The bracket must move freely.

2. Install the outer control arm bracket (101), bushing (106), washer (99), and bolt (102). Tighten to the correct torque value. See page 92.

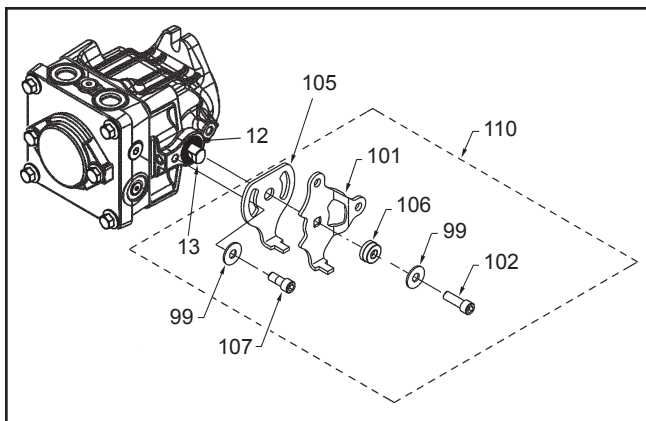

Figure 2. PR Pump Standard Control Arm

REMOVAL, INSPECTION AND/OR REPLACEMENT OF FAN ASSEMBLY

Refer to Figure 3.

Disassembly

1. Remove the fan shroud (210) from the mounting bracket (209) by carefully pushing down on the shroud tabs.
2. Remove the fan nut and fan assembly (90).
3. Remove the bolts (56) and bracket (209).

Inspection

Inspect the fan shroud (210), fan assembly (90) and mounting bracket (209) for damage.

Assembly

1. To install the mounting bracket (209), align and insert the bolts (56) into the bracket and charge pump cover. While holding the charge cover in place, tighten the bolts (56) per table 2, page 92.
2. Install the fan and washer assembly onto the shaft.
3. Install the fan nut and tighten per table 2, page 92.
4. Install the fan shroud (210) onto the mounting bracket (209). Make sure that all shroud lock tabs are fully engaged in the mounting bracket slots.

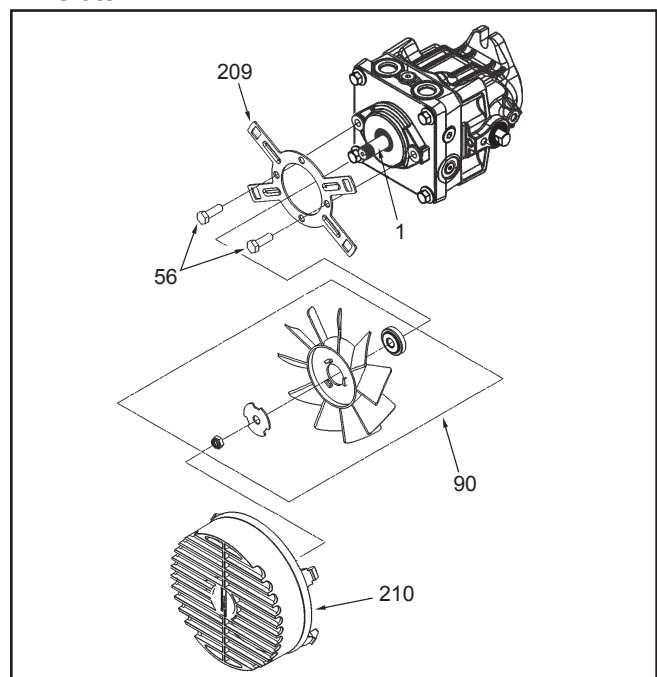

Figure 3. PR Pump Fan Assembly

REMOVAL, INSPECTION AND/OR REPLACEMENT OF INPUT SHAFT SEAL

Refer to Figure 4.

Disassembly

1. Remove retaining ring (3) from housing (15).
2. Remove lip seal (6). Care must be taken to prevent damage to the housing bore, shaft sealing surface, or bearing. Once removed, the seal is not reusable.

Inspection

1. With the lip seal (6) removed, inspect the spacer (4), shaft bearing (5) and housing (15) bore.

Assembly

1. Lubricate the new lip seal (6) with petroleum jelly.
2. Wrap the input shaft (1) with plastic wrap to prevent damage to the inner surface of the lip seal (6).
3. Slide the seal (6) over shaft (1) so that lettering on the seal (6) faces out.
4. Press the lip seal (6) into the housing (15) bore. Insure seal (6), shaft (1) or housing (15) bore do not become damaged.
5. Remove the plastic wrap.
6. Install the retaining ring (3) into the housing (15) bore groove.

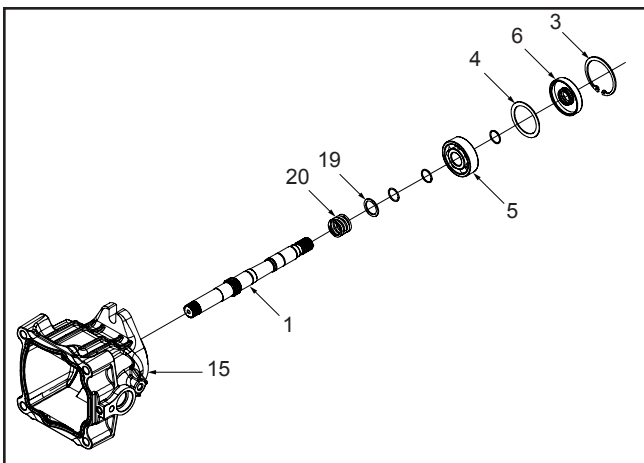

Figure 4. PR Pump Input Shaft Seal

REMOVAL, INSPECTION AND/OR REPLACEMENT OF TRUNNION ARM (CONTROL ARM) SEAL

Refer to Figure 5.

Disassembly

1. Remove the retainer and lip seal (12) from the housing (15). Care must be taken to prevent damage to the housing trunnion bore, trunnion arm (13) and sealing surface. Once removed the retainer and lip seal is not reusable.

Inspection

1. With the lip seal (12) removed, inspect the area for corrosion and wear. Inspect the trunnion bore area sealing surface for damage or wear.

Assembly

1. Lubricate the new lip seal (12) with petroleum jelly.
2. Wrap the trunnion arm (13) with plastic wrap to prevent damage to the inner surface of the lip seal (12).
3. Slide the lip seal (12) over the trunnion arm (13) so that the lettering on the seal (12) faces out.
4. Press the lip seal (12) into the housing bore (15). Insure the seal (12), trunnion arm (13), and housing bore do not become damaged. Remove the plastic wrap.
5. Install the retainer from (12) over the trunnion arm (13) on top of the lip seal (12). Press into the trunnion seal bore in the housing until the retainer mates against the trunnion seal.

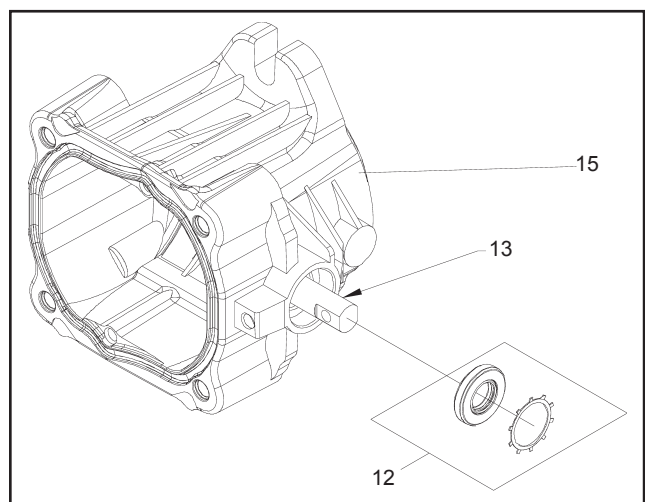

Figure 5. PR Pump Trunnion Arm Seal

REMOVAL, INSPECTION AND/OR REPLACEMENT OF CHECK VALVES

Refer to Figure 6.

Disassembly

Perform disassembly, inspection and assembly on check valves one side at a time. Some units vary in “A” side to “B” side check configuration.

1. Remove the check valve (42) with an 1/4” allen wrench.
2. Remove the valve spring and poppet from the end cap (25).

Inspection

1. Inspect the poppets and mating seats in the end cap (25) for damage or foreign material.

Assembly

1. Lay the pump on its side, so the check plug port is horizontal.
2. Insert the check plug, spring and poppet (42) as one assembly into the check plug port. Tighten, reference Table 2, page 92 for torque values.
3. Repeat disassembly, inspection and assembly for the opposite port side.

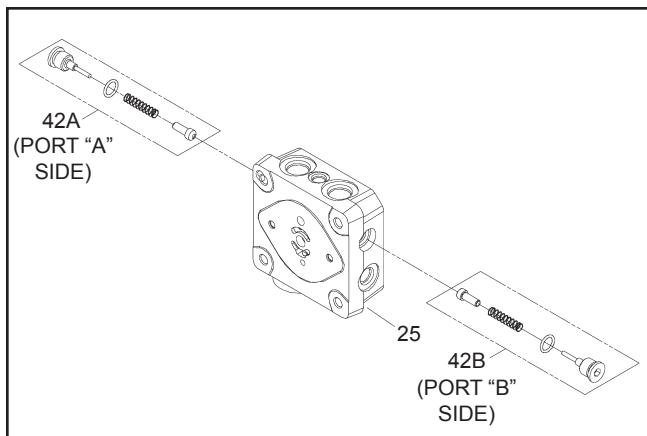

Figure 6. PR Pump Check Valves

REMOVAL, INSPECTION AND/OR REPLACEMENT OF SYSTEM CHECK RELIEFS (SCR'S) OR SHOCK VALVES

Refer to Figure 7.

Disassembly

Perform disassembly, inspection and assembly on SCR/shock valve one side at a time. Some units vary in “A” side to “B” side configuration.

1. Remove the SCR (42) with a 7/8” wrench or the shock valve (42) with an 11/16” wrench.
2. Remove the check relief/shock valve spring and the check relief/shock valve from the end cap (25).

Inspection

1. Inspect the check relief or shock valve (42) and mating seat in the end cap (25) for damage or foreign material.

Assembly

1. Lay the pump on its side, so the check plug port is horizontal.
2. Insert the system check relief spring and check relief or shock valve spring and shock valve as one assembly into the check plug port. Tighten to the correct torque value. See page 92.
3. Repeat disassembly, inspection and assembly for the opposite port side.

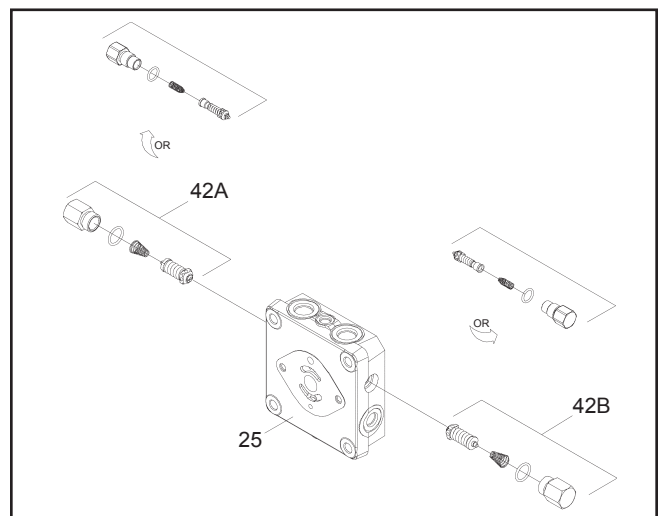

Figure 7. PR Pump Shock Valves

REMOVAL, INSPECTION AND /OR REPLACEMENT OF THE BYPASS

Refer to Figure 8.

Disassembly

1. Loosen the bypass valve (50) using a 5/8" wrench.
2. Remove the bypass (50) from the end cap (25).

Inspection

1. Inspect the bypass O-rings and mating seats in the end cap (25) for damage or foreign materials.
2. If damaged or worn replace bypass (50).

Assembly

1. Lay the pump on its side, so the bypass port is horizontal.
2. Insert the bypass (50) into the bypass port on the end cap (25). Tighten to the proper torque value. See page 92.

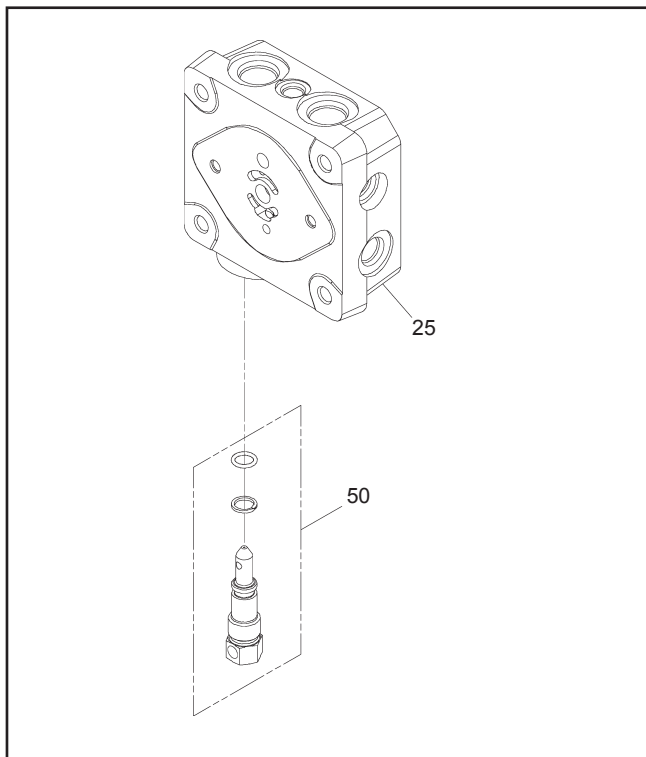

Figure 8. PR Pump Bypass

REMOVAL, INSPECTION AND ASSEMBLY OF STANDARD OR THRU SHAFT CHARGE PUMP

Refer to Figure 9.

Disassembly

1. Prior to removal of the charge pump cover, place a mark on the cover and end cap for alignment at assembly.
2. Using a 1/2 inch wrench loosen the charge pump cover bolts (56) from the end cap (2). While holding the charge cover in place, remove the charge cover bolts (56).
3. Remove the charge cover, O-ring (39) and gerotor items (41). Carefully check for and remove the charge spring and charge ball (44).
4. For the Thru Shaft charge pump, remove the shaft seal.

Inspection

1. Inspect the charge cover O-ring and running surfaces for damage. Inspect the spring, check ball (44), and mating seat in the end cap for damage or foreign material.

NOTE: If the end cap (2) is to be removed from the housing, do not assemble the charge pump (40) until the end cap is installed on the housing.

2. Inspect the charge cover bore for damage, corrosion or wear.

Assembly

NOTE: For the Thru Shaft charge pump follow steps 1-8. For the Standard charge pump follow steps 3-8.

1. Lubricate the new shaft seal with petroleum jelly.
2. Press the shaft seal into the charge cover. Be careful not to damage the seal or charge cover bore.
3. Position the pump with the input shaft down, and the end cap (25) horizontal. Place the charge ball (44) in the end cap (25) charge passage so the ball mates to the end cap (25) charge ball seat. Place the charge spring, on top of the charge ball.
4. Insert the outer gerotor over input shaft.
5. Align the outer gerotor to fit over the inner gerotor.
6. Insert the O-ring (39) into the groove in the charge cover.
7. Position the charge cover and O-ring (39) with the aligning mark on the end cap (25). Place the charge cover and O-ring with aligning mark on the end cap. Place the charge cover and O-ring as one piece over the charge spring and gerotor assembly. Insure the spring fits into the charge cover spring retaining groove.
8. Align and insert the charge pump cover bolts (56) into the end cap (25). Tighten to the correct torque value. See Table 2, page 92. (Torque Values.)

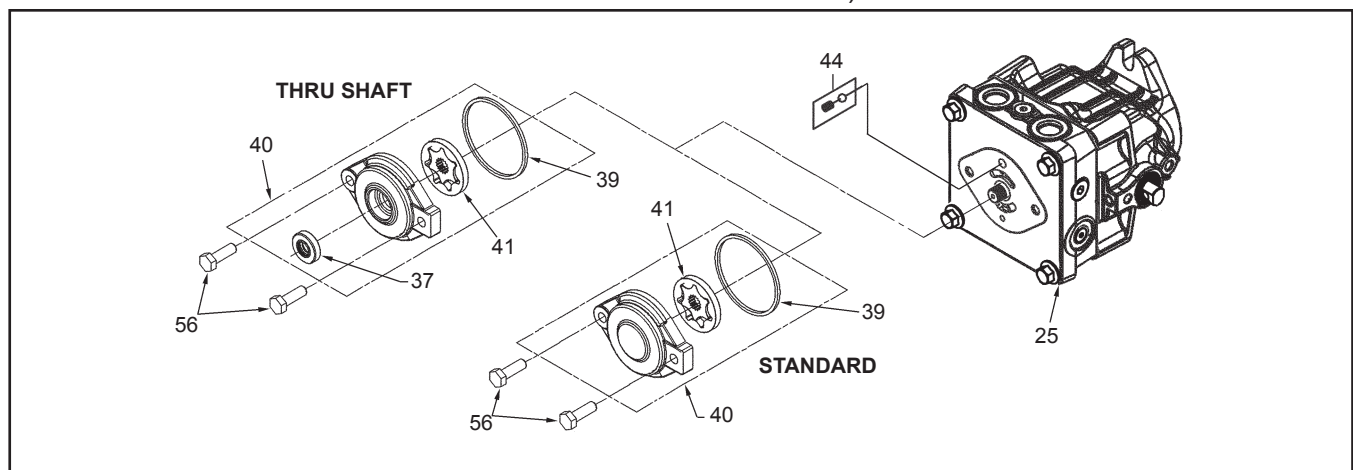

Figure 9. PR Pump Standard or Thru Shaft Charge Pump

REMOVAL, INSPECTION AND/OR REPLACEMENT OF AUXILIARY PUMP (IF EQUIPPED)

Refer to Figure 10.

Disassembly

1. Prior to removal of the auxiliary pump, place a mark on the auxiliary pump, charge pump (41) and end cap (25) for alignment at assembly.
2. Use a 10mm wrench to loosen the auxiliary pump bolts (56) from the end cap (25). While holding the auxiliary pump in place, remove the bolts (56).
3. Remove the auxiliary pump, gasket, O-ring (39) and charge pump (41). While removing the charge pump, be sure to retain the spring and ball (44) housed in the end cap (25).
4. Remove the plug (156) from the filter cover (67).
5. Use a 7/8 inch wrench to remove the filter cover assembly (67) from the auxiliary pump.
6. Remove the O-ring and filter (54).
7. Remove the charge relief valve assembly (49) and auxiliary relief valve assembly (45) from the auxiliary pump.

Inspection

1. With the auxiliary pump removed, inspect the pump running surfaces for wear or damage.

2. Inspect all O-rings, gasket and mounting seats.
3. Inspect the filter cover assembly threads and filter for wear, damage or foreign material.

Assembly

1. Install the check ball, spring, and cap as one assembly (45) into the auxiliary relief valve port. Tighten to the correct torque value. See page 92.
2. Install the poppet, spring and cap as one assembly (49) into the charge relief port. Tighten to the correct torque value. See page 92.
3. Install the filter (54) and O-ring onto the filter cover assembly (67). Install the assembly (67) into the auxiliary pump and tighten. Install plug (156) into the filter cover (67). See page 92 for the correct torque value.
4. Lay the PR pump (input shaft down), so the end cap is horizontal. Install the O-ring (39) into the charge pump (41).
5. Install the gasket onto the auxiliary pump.
6. Make sure that the ball and spring (44) are seated in the end cap (25), then position the auxiliary pump and gasket with the aligning mark on the charge pump (41). Insure that the pump fully engages the alignment pins (69).
7. Align and insert the bolts (56) into the auxiliary pump. While holding the auxiliary pump and charge pump in place, tighten the bolts (56) per table 2, page 92.

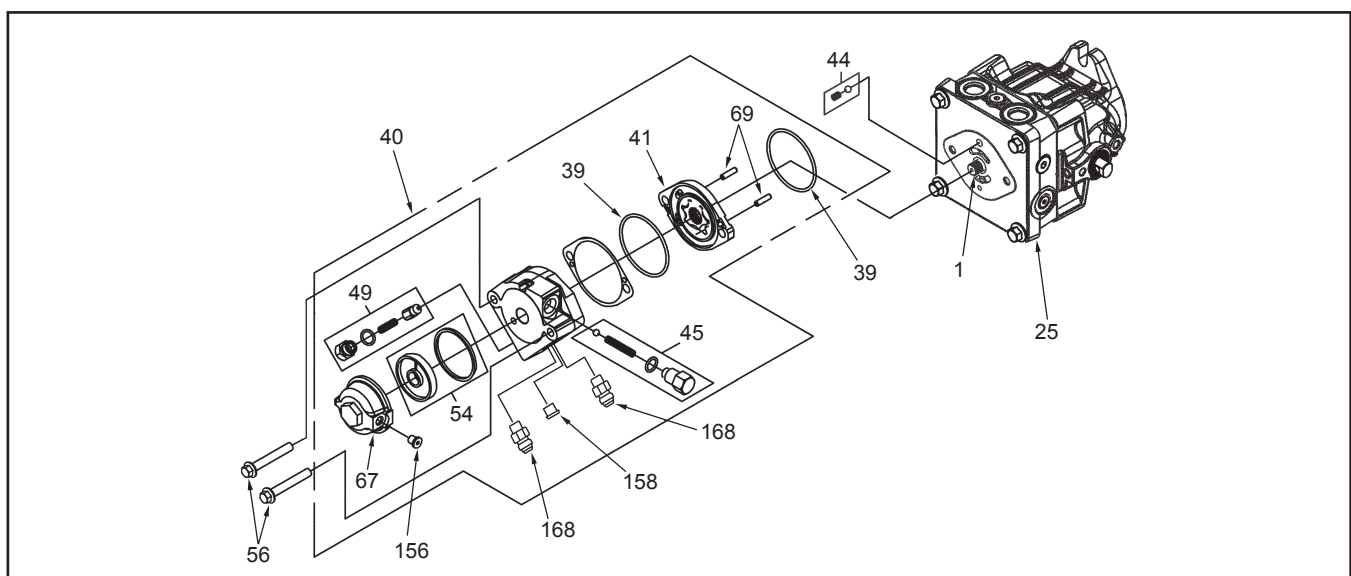

Figure 10. PR Series Auxiliary Pump

REMOVAL, INSPECTION AND ASSEMBLY OF THE END CAP AND VALVE PLATE

Refer to Figure 11.

Disassembly

1. Using any combination of two, 9/16" wrenches or 9/16" socket and ratchet drive, loosen the end cap bolts (58) evenly.
2. Keeping the end cap (25) held in place, remove the four end cap bolts (58).
3. Slowly remove the end cap (25).
4. Remove the valve plate (29).

NOTE: This step is only applicable on PR series pumps built prior to 0216Pxxxxx.

5. Remove housing alignment pins (26).
6. Remove housing gasket (28).

Inspection

1. Inspect the end cap (25) body for damage, nicks or unusual wear patterns. Replace if necessary.
2. Inspect the running surface (side that contacts the cylinder block) of the valve plate (29) and/or end cap (25). The running surface may show evidence of minor abrasive rings, this is normal.

NOTE: Grooving in the valve plate and/or end cap, made evident when the surface is checked by dragging a fingernail across it, would be cause for replacement of the valve plate.

3. Inspect and replace alignment pins (26) if bent or distorted.
4. Replace the housing O-ring (28) with a new O-ring before reassembly.

Assembly

1. Install O-ring (28) into the O-ring seat of housing (15).
2. Install alignment pins (26) into housing (15).
3. Lubricate the valve plate prior to installation. Install valve plate (29) so the bronze side of the valve plate is facing down toward the cylinder block.

NOTE: This step is only applicable on PR series pumps built prior to 0216Pxxxxx.

4. On pumps built without a valve plate, lubricate the end cap (25) prior to installation.
5. Install end cap (25). Before installing the four end cap bolts (58), push down on the end cap (25) verifying alignment and insuring that the cylinder block pistons spring back and forth. Install and torque end cap bolts (58). Reference Table 2, page 92 (torque values).

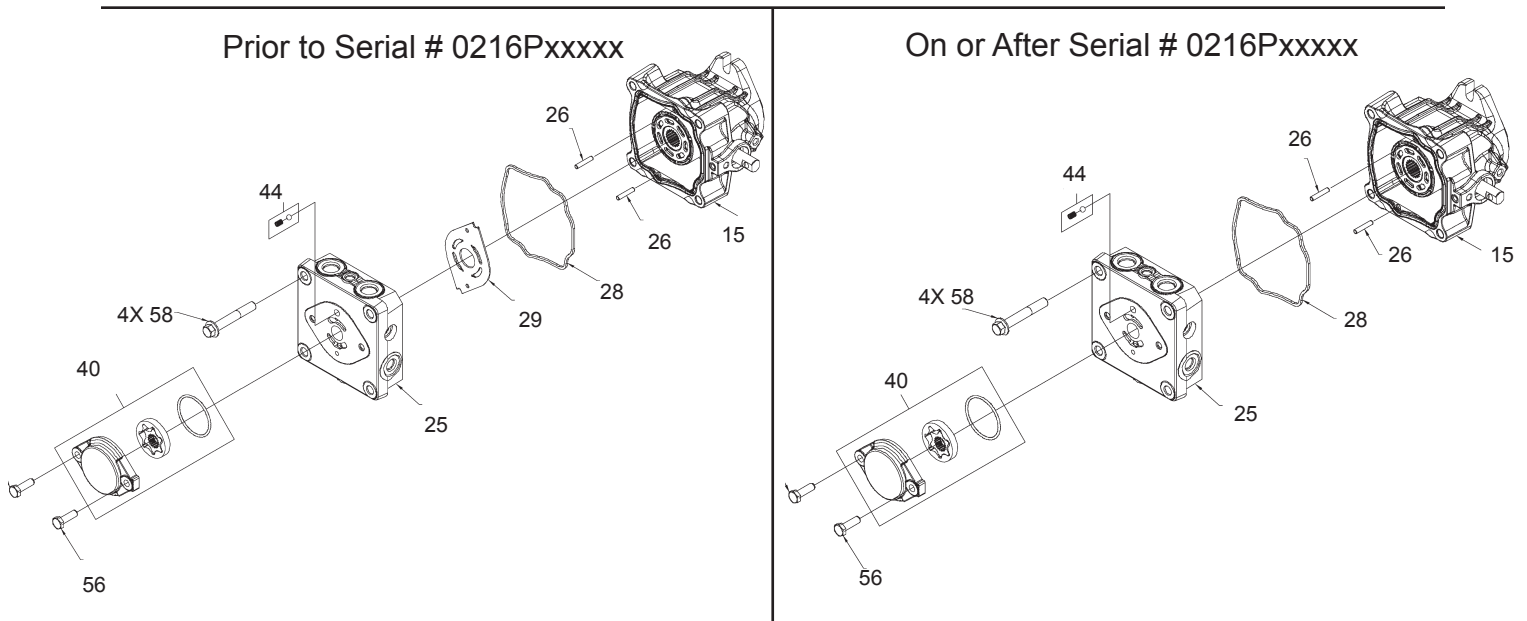

Figure 11. PR Pump End Cap

REMOVAL, INSPECTION AND ASSEMBLY OF THE CYLINDER BLOCK

Refer to Figure 12.

Disassembly

1. Tilt the pump on its side, drain remaining oil. Lift out the cylinder block assembly (38).
2. Remove the pistons, springs and piston seats.

Inspection

1. Inspect the running surface of the cylinder block and piston ends for damage, nicks or unusual wear patterns.

The running surface may show evidence of minor abrasion. This will be normal wear. If grooved or smeared, replace with a new cylinder block assembly.

2. Inspect the piston springs for distortion or breaks. If necessary, replace with a new cylinder block kit.
3. Inspect the piston seats. Residual oil may cause these to remain stuck to the inside of the pistons.

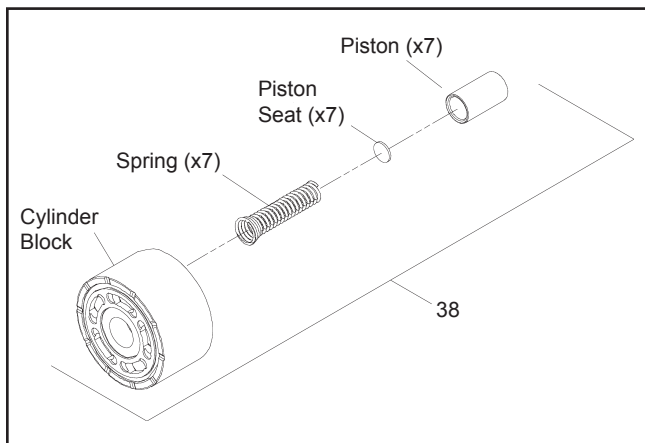

Figure 12. PR Pump Cylinder Block

Assembly

1. Install piston seats into the end of the pistons.
2. Install springs into the pistons.
3. Install one at a time, pistons, springs and seats as one assembly into the cylinder block.
4. With the pump housing tilted on its side, install the cylinder block assembly (38) with pistons contacting the thrust bearing.

NOTE: To check that piston placement is correct, push downward on the cylinder block assembly (38). If this results in a spring action the block assembly has been installed correctly. If this cannot be accomplished, remove and reassemble the block assembly. Place a rubber band around the cylinder block pistons to hold them in position during installation. Then after installation cut the rubber band and remove it. Check cylinder block assembly for spring action.

REMOVAL, INSPECTION AND ASSEMBLY OF BLOCK SPRING, THRUST WASHER, AND THRUST BEARING

Refer to Figure 13.

Disassembly

1. Remove the block spring (20).
2. Remove the thrust washer (19).
3. Remove the thrust bearing and race (17).

Inspection

1. Inspect and replace the block spring (20) and thrust washer (19) if they are distorted or broken.
2. Inspect the running surface of the bearing race for damage, nicks or unusual wear patterns. The running surface may show evidence of minor abrasion. This will be normal wear.

Inspect the bearings for free movement. Inspect the bearing cage for distortion or damage. Replace if necessary.

Assembly

1. Install thrust bearing and race assembly (17).

NOTE: The difference in race thicknesses: The thin race seats into the swashplate. The thicker race will be installed toward the piston noses.

2. Install thrust washer (19).
3. Install block spring (20).

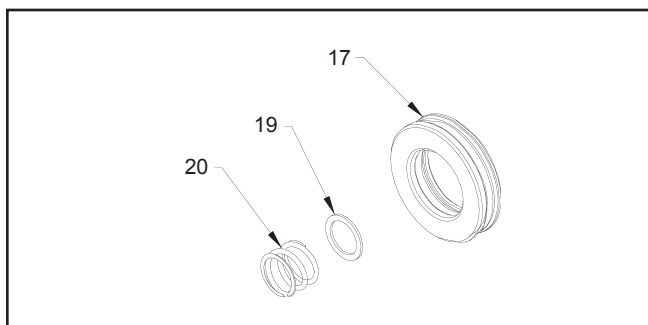

Figure 13. PR Pump Block Spring and Thrust Bearing

REMOVAL, INSPECTION OF SWASHPLATE, INSPECTION OF CRADLE BEARINGS

Refer to Figure 14.

Disassembly

1. Remove the swashplate (31).

Inspection

1. Inspect the running surface of the bearing pocket for damage (31), nicks or unusual wear patterns. The running surface may show evidence of minor abrasion. This is normal wear. Inspect the cradle bearing side of the swashplate (31) for damage. Replace if necessary.
2. Inspect the cradle bearings attached to the inside of the housing (15) for normal wear patterns, placement, and insure they are staked securely in place. If damaged, replace housing (15).

NOTE: The cradle bearings will have discoloration due to normal wear. Under normal circumstances, this will not warrant replacement.

Assembly

1. Install swashplate (31) by holding trunnion arm's (13) slot guide (14) with a flat tip screwdriver. Use the screwdriver to hold the slot guide (14) in place while positioning the swashplate (31) onto the cradle bearing in the housing (15).
2. Rotate trunnion arm (13) to assure swashplate pivoting action.

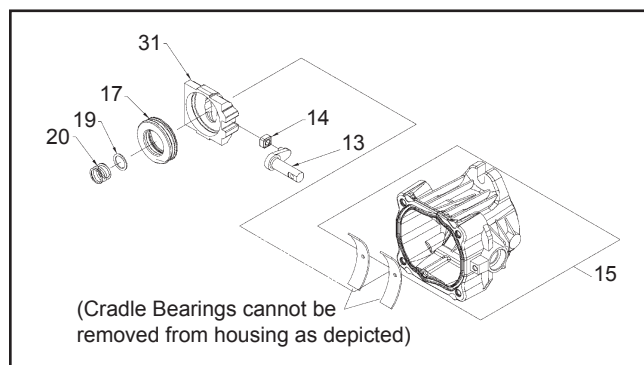

Figure 14. PR Pump Swashplate and Cradle Bearings

REMOVAL, INSPECTION AND ASSEMBLY OF INPUT SHAFT

Refer to Figure 15.

Disassembly

1. Remove the retaining ring (3).
2. Remove the lip seal (6).
3. Remove the spacer (4).
4. Remove the shaft assembly (1).

Inspection

1. Inspect the input shaft (1) for worn splines, damage, or keyway damage. Replace shaft assembly if necessary.
2. Inspect the bearing (5) for evidence of scoring, corrosion, or damage. Replace shaft assembly if necessary.
3. Inspect and replace the spacer (4) if it is bent or broken.

NOTE: Replace the input shaft seal (6) after removal.

4. Inspect and replace the retaining ring (3) if it is bent or broken.

NOTE: If trunnion arm is to be removed, delay reassembly of input shaft assembly.

5. Inspect and replace the thrust spring (20) and thrust washer (19) if they are distorted or broken.

Assembly

NOTE: Upon removal, it is recommended that all seals, O-rings and gaskets be replaced. During installation, lightly lubricate all seals, O-rings and gaskets with clean petroleum jelly prior to assembly. Also, protect the inner diameter of seals by covering the shaft with plastic wrap.

1. Install input shaft assembly (1) into the housing (15) bore. Light tapping with a rubber mallet may be necessary on the input shaft (1) once the bearing is aligned with the housing bore (15). Rotate the input shaft (1) to insure free movement.
2. Install spacer (4).
3. Install new lip seal (6).
4. Install retaining ring (3).

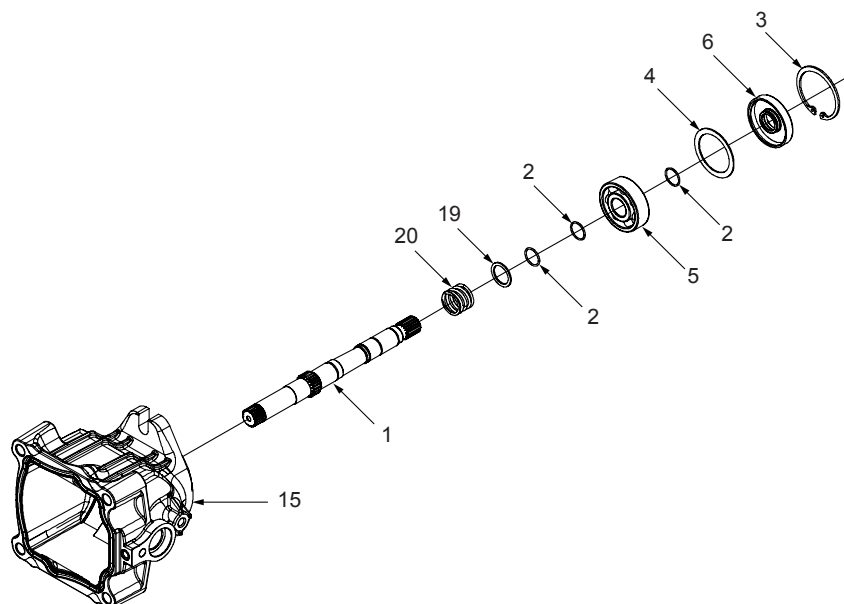

Figure 15. PR Pump Input Shaft

REMOVAL AND INSPECTION OF TRUNNION ARM

Refer to Figure 16.

Disassembly

1. Remove and discard the trunnion seal retainer and seal (12).
2. Remove the slot guide (14).
3. Remove the trunnion arm (13).

Inspection

1. Inspect the trunnion arm (13) for wear or damage. Replace the trunnion arm if necessary.

Assembly

1. Install the trunnion arm (13) into the housing (15) bore. Rotate the trunnion arm to verify free movement.
2. Install a new seal and seal retainer (12).
3. Install the slot guide (14).
4. To completely reassemble the pump, refer to the assembly steps on pages 93-104. Begin with the trunnion arm assembly steps listed on page 90 and complete the assembly steps in reverse order working towards the front of the manual.

NOTE: Upon removal, it is recommended that all seals, O-rings, and gaskets be replaced. During installation, lightly lubricate all seals, O-rings and gaskets with clean petroleum jelly prior to assembly. Also protect the inner diameter of seals by covering the shaft with plastic wrap. Remove the plastic wrap after the seal is installed.

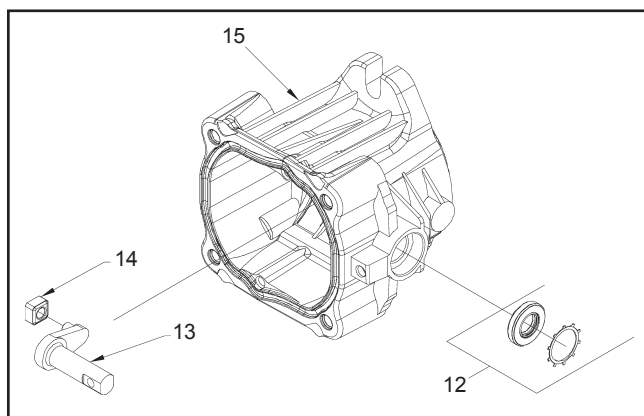
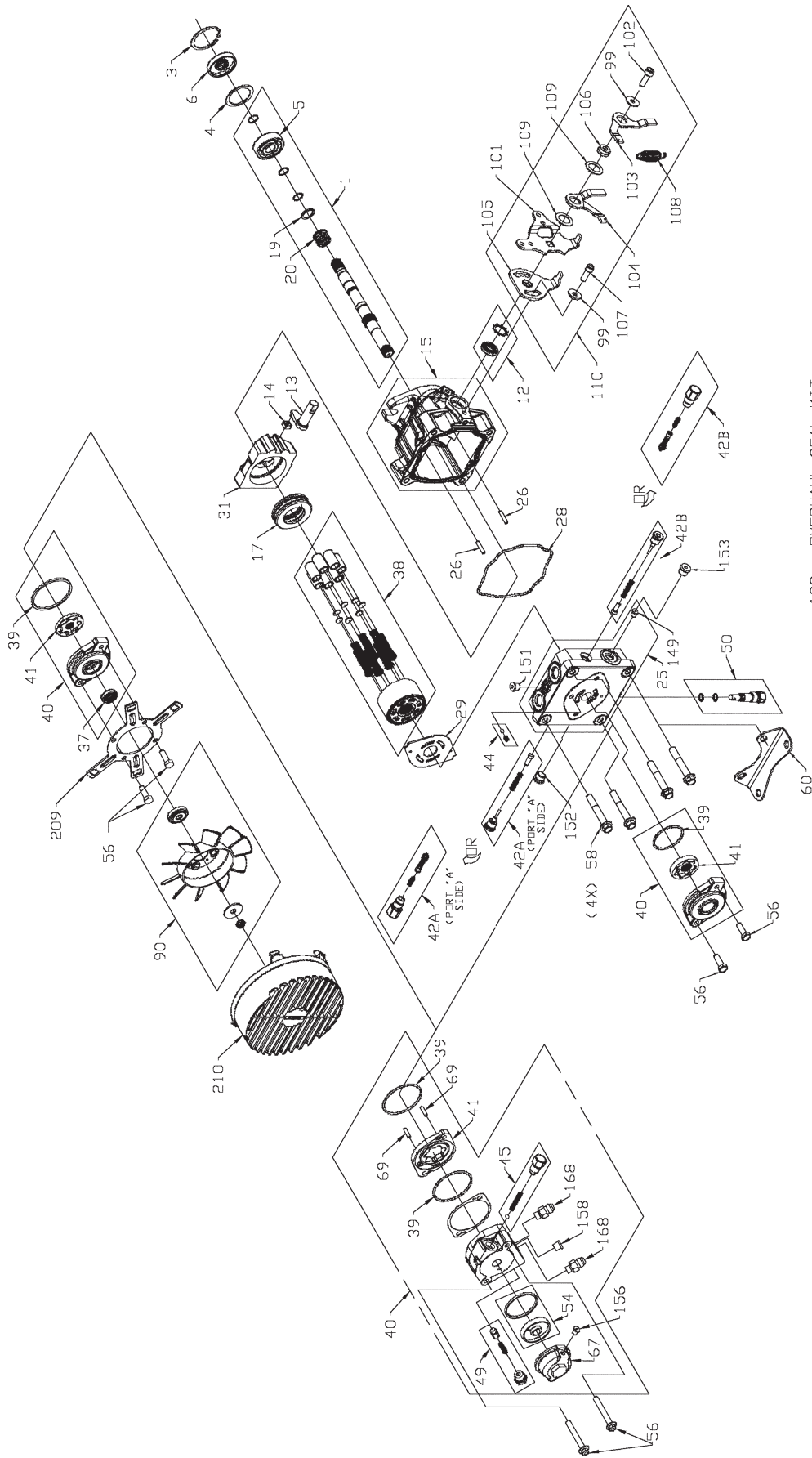

Figure 16. PR Pump Trunnion Arm



100 - OVERHAUL SEAL KIT

BOXES INDICATE ITEMS INCLUDED IN KITS.

Kit Number

Figure 17. PR Pump

ITEM LIST - PR SERIES

Part numbers are not provided in this manual. See CD (BLN-51427) for part numbers.

No.	Description	No.	Description
1	Pump Shaft Kit (19T spline)		Shock Valve Kit (.031" orifice)
	Pump Shaft Kit (17 mm keyed)		Shock Valve Kit (.044" orifice)
	Pump Shaft Kit (17 mm keyed thru taper)		
	Pump Shaft Kit (double tapered thru shaft)	44	Charge Relief Kit (1/4" plastic ball & spring)
3	Retaining Ring		Charge Relief Kit (1/4" plastic ball & spring)
4	Spacer		Charge Relief Kit (w/ 9/16" SAE valve plug 40-70 psi)
5	Shaft Ball Bearing		Charge Relief Kit (w/ 9/16" SAE valve plug 75-105 psi)
6	Lip Seal 17 X 47 X 8 PTCN1		Charge Relief Kit (w/ 1/2" SAE valve plug 40-70 psi)
12	Trunnion Seal Kit		Charge Relief Kit (w/ 1/2" SAE valve plug 135-1650 psi)
13	Trunnion Arm	45	Aux Relief Valve Kit
14	Slot Guide	49	Aux Bypass/Check Kit
15	Housing Kit	50	Bypass Valve Kit (blank orifice)
17	Thrust Ball Bearing Assembly		Bypass Valve Kit (.031" orifice)
19	Block Thrust Washer		Bypass Valve Kit (.043" orifice)
20	Block Spring	54	Auxiliary Filter Kit
25	End Cap Kit (w/poppets & std chg)	56	Socket Hd Cap Screw (M8 x 1.25-25mm)
	End Cap Kit (w/poppets & aux chg)		Flange Hd Screw (5/16-18 x 2.5)
26	Pin	58	Hex Screw, Flanged Hd (M10 x 1.50-65 mm)
28	O-Ring	60	Mounting Bracket
29	Valve Plate	67	Filter Cover
31	Variable Swashplate	69	Dowel Pin
38	Cylinder Block Kit (16cc)	90	Fan Kit
39	O-Ring	99	Washer
	R-Ring (-144)	100	Seal Kit
40	Charge Pump Kit (.19 std splined)	101	Control Arm
	Charge Pump Kit (.13 std thru shaft)	102	Screw
	Charge Pump Kit (CW-Iron Aux, 40-70 psi, .001" shim)	103	Outer Scissor Arm
	Charge Pump Kit (CW-Iron Aux, 135-165 psi, .001" shim)	104	Inner Scissor Arm
	Charge Pump Kit (CCW-Iron Aux, 70-70 psi, .001" shim)	105	Return Arm
	Charge Pump Kit (AI Aux, 7/16 SAE port, 40-70 psi, .001" shim)	106	Spacer
	Charge Pump Kit (AI Aux 7/16 SAE port, 75-105 psi, .001" shim)	197	Screw
41	Gerotor Assembly (.13 cu.in./rev)	108	Spring
	Gerotor Assembly (.19 cu.in./rev)	109	Washer
	Aux Gerotor & Hsg Assembly (0.19 cu.in./ rev)	110	Return Kit
42	Check Valve Kit (blank orifice)	149	Plug
	Check Valve Kit (0.24" orifice)	150	Plug
	Check Valve Kit (.031" orifice)	151	Plug
	Check Valve Kit (.044" orifice)	152	Plug
	Shock Valve Kit (blank orifice)	153	Plug
	Shock Valve Kit (.024" orifice)	156	Plug
		158	Plug
		168	Connector
		209	Shroud Bracket
		210	Shroud

REPAIR - PW / PY SERIES PUMP

Repair - PW / PY Series Pump.....	109-126
How to Use This Manual.....	109
General Instructions	109
Tools and Torques	110
Return to Neutral Linkage.....	111
Standard Control Arm Linkage	112
Fan Assembly	112
Input Shaft Seal.....	113
Trunnion Arm Seal.....	113
Check Valves.....	114
Shock Valves.....	114
Bypass.....	115
Charge Pump-Standard or Thru Shaft.....	116
Auxiliary Pump.....	117
Auxiliary Pump (6cc Piston).....	118
End Cap.....	119
Cylinder Block.....	120
Block Spring and Thrust Bearings	121
Swashplate and Cradle Bearings	121
Input Shaft	122
Trunnion Arm	123
Parts List.....	124-125

HOW TO USE THIS MANUAL

Each assembly is provided with an exploded view showing the parts involved. **The item reference numbers in each illustration are for assembly instructions only.** See pages 124 and 125 for part names and descriptions. A complete exploded view and item list of the pump is provided at the end of this section.

GENERAL INSTRUCTIONS

Cleanliness is a primary means of ensuring satisfactory life on repaired pumps. Thoroughly clean all exposed surfaces prior to any type of maintenance. Cleaning of all parts by using a solvent wash and air drying is usually adequate. As with any precision equipment, all parts must be kept free of foreign material and chemicals.

Protect all exposed sealing surfaces and open cavities from damage and foreign material. The external surfaces should be cleaned before beginning any repairs.

Lip-type seals (shaft seals) are used on the input shaft and directional control shaft of each Pump. These seals can be replaced without major disassembly of the unit. However, replacement of these seals generally requires removal of the pump from the machine. Upon removal, it is recommended that all seals, O-rings and gaskets be replaced.

During installation, lightly lubricate all seals, O-rings and gaskets with clean petroleum jelly prior to assembly. Also protect the inner diameter of the seals by covering the shaft with a cellophane (plastic wrap, etc.) material.

Parts requiring replacement must be replaced from the appropriate kits identified in the Items Listing, found at the end of this manual. Use only original Hydro-Gear replacement parts found listed in BLN-51427 (CD).

TOOLS AND TORQUES

Miscellaneous	3/8-Inch Drive Ratchet and Sockets
P Series Service & Repair Manual	1/2-inch Socket
Torque Wrench	9/16-inch Socket
Scribe, Paint Pen, or Marker	5/8-inch Socket
Seal Hook with a Magnet	10-mm Socket
Flat Blade Screwdriver	
	Combination Wrenches
Pliers	1/2 inch
Internal Snap Ring	9/16 inch
	5/8 inch
Allen Wrenches	7/8 inch
5mm	10 mm
3/16 inch	
1/4 inch	

Table 1. Required Tools

Item # and/or Description	Torque
Case Drain (fitting torque)	370-470 lb-in (41.8-53.1 Nm)
System Port (fitting torque)	370-470 lb-in (41.8-53.1 Nm)
Inlet (fitting torque)	370-470 lb-in (41.8-53.1 Nm)
Fan Nut, Hex Lock 3/8-24 UNF	180-220 lb-in (20.3-24.9 Nm)
42A, 42B, Shock Valves/Check Plugs	180-240 lb-in (20.3-27.1 Nm)
44, Charge Relief Kit	180-240 lb-in (20.3-27.1 Nm)
45, Aux Relief Valve Kit	180-240 lb-in (20.3-27.1 Nm)
49, Aux Bypass/Check Kit	180-240 lb-in (20.3-27.1 Nm)
50, Bypass Valve	110-130 lb-in (12.4-14.7 Nm)
56, Screw	180-220 lb-in (20.3-24.9 Nm)
58, Housing Bolt	255-300 lb-in (28.8-38.9 Nm)
66, Steel Plug	55-85 lb-in (6.2-9.6 Nm)
67, Filter Cover	200-275 lb-in (22.6-31.1 Nm)
70, Relief Valve	180-240 lb-in (20.3-27.1 Nm)
79, Pan Head Screw	100-130 lb-in (11.2-14.6 Nm)
158, Plug 9/16	110-150 lb-in (12.4-16.9 Nm)
166, Plug	6-12 lb-in (.6-1.3 Nm)
167, Plug	6-12 lb-in (.6-1.3 Nm)
Screw, Socket Hd. Control Arm 5/16-24 x .75	200-240 lb-in (22.6-27.1 Nm)
Screw, Socket Hd. RTN M8 x 1.25 x 25	180-220 lb-in (20.3-24.9 Nm)

Table 2. PW / PY Pump Torque Values

PW / PY SERIES PUMP REPAIR

REMOVAL, INSPECTION AND/OR REPLACEMENT OF RETURN TO NEUTRAL ASSEMBLY

Prior to disassembly, note the position of the scissor arm brackets and the tab on the outer control arm bracket.

See Figure 1.

Disassembly

CAUTION: The spring used on the return to neutral linkage is under tension. To avoid possible injury, use care and proper protection during disassembly and assembly of the return to neutral linkage.

1. Loosen (but do not remove) the bolt (112).
2. To relieve spring tension, carefully pry up on the outer scissor control arm until it releases from the tab on the outer control arm bracket.
3. Remove the spring (18), bolt (112) washer (109) and outer scissor arm bracket (113).
4. Remove bushing (116), washer (119), and the inner scissor control arm bracket (114).
5. Remove the outer control arm bracket (111), bolt (117), washer (109), and inner control arm bracket (115).

Inspection

1. With the arm control linkage removed, inspect the trunnion arm and trunnion arm seal.
2. Inspect bushing (116) and all other linkage parts for damage, corrosion or wear.

Assembly

1. Install the inner control arm bracket (115), washer (109) and bolt (117).

NOTE: Do not over tighten the bolt (117). The bracket must move freely.

2. Install the outer control arm bracket (111), washer (119) and bushing (116).
3. Install the inner scissor arm bracket (114), washer (119), and outer scissor arm bracket (113).
4. Install washer (109), and bolt (112). Tighten to the correct torque value. See page 110.
5. Install the spring (18).

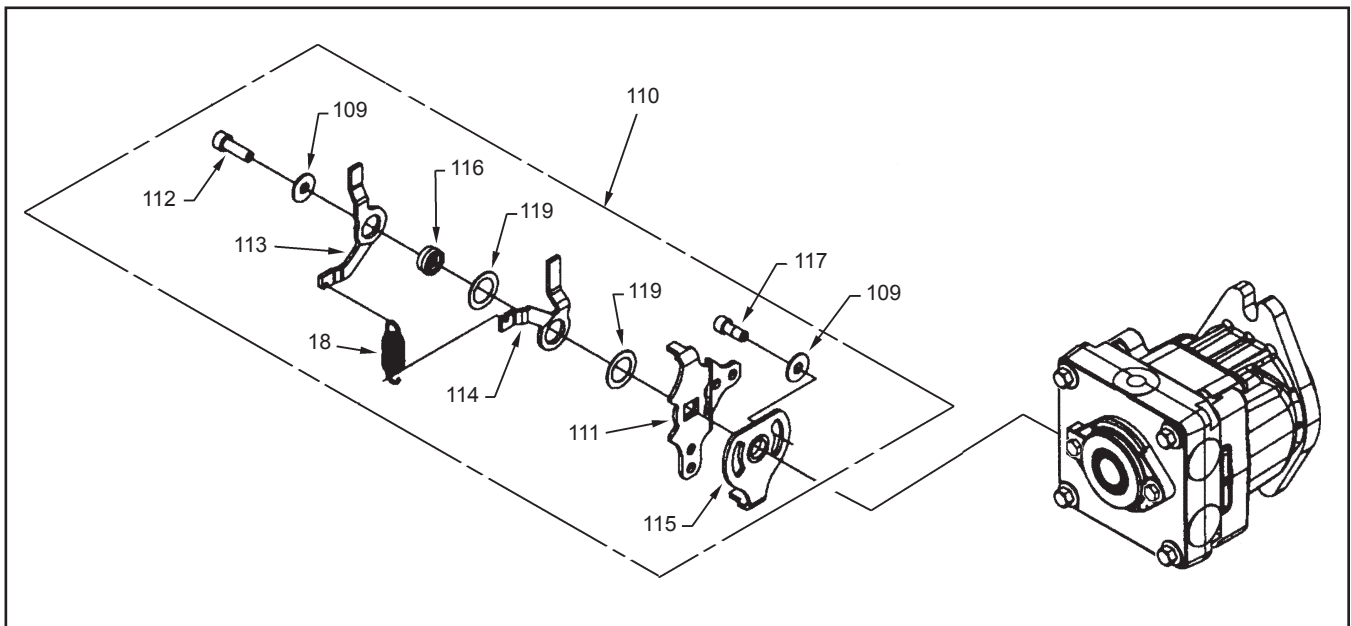

Figure 1. PW / PY Pump Return to Neutral

REMOVAL, INSPECTION AND/OR REPLACEMENT OF CONTROL ARM

Refer to Figure 2.

Disassembly

1. Remove the bolt (112), washer (109) and bushing (116).
2. Remove the outer control arm bracket (111).
3. Remove bolt (117), washer (109) and the inner control arm bracket (115).

Inspection

1. With the arm control linkage removed, inspect the trunnion arm and trunnion arm seal.
2. Inspect bushing (116) and all other linkage parts for damage, corrosion or wear.

Assembly

1. Install the inner return arm bracket (115), washer (109) and bolt (117).

NOTE: Do not over tighten the bolt (117). The bracket must move freely.

2. Install the outer control arm bracket (111), bushing (116), washer (109) and bolt (112). Tighten to the correct torque value. See page 110.

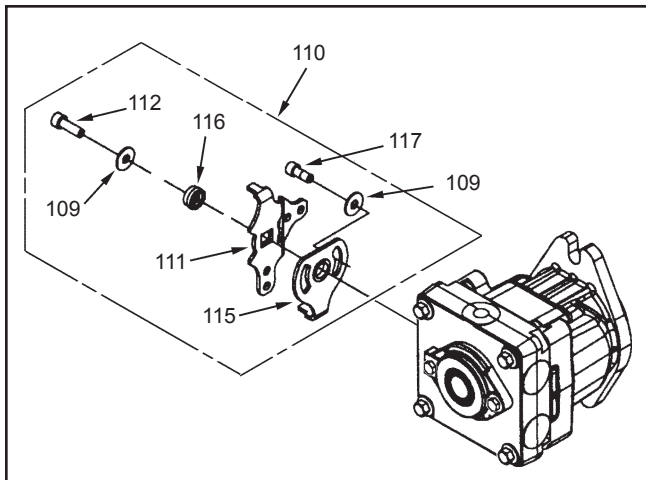

Figure 2. PW / PY Pump Standard Control Arm

REMOVAL, INSPECTION AND/OR REPLACEMENT OF FAN ASSEMBLY

Refer to Figure 3.

Disassembly

1. Remove the fan shroud (210) from the mounting bracket (209) by carefully pushing down on the shroud tabs.
2. Remove the fan nut and fan assembly (90).
3. Remove the bolts (56) and bracket (209).

Inspection

Inspect the fan shroud (210), fan assembly (90) and mounting bracket (209) for damage.

Assembly

1. To install the mounting bracket (209), align and insert the bolts (56) into the bracket and charge pump cover. While holding the charge cover in place, tighten the bolts (56) per table 2, page 110.
2. Install the fan and washer assembly onto the shaft.
3. Install the fan nut and tighten per table 2, page 110.
4. Install the fan shroud (210) onto the mounting bracket (209). Make sure that all shroud lock tabs are fully engaged in the mounting bracket slots.

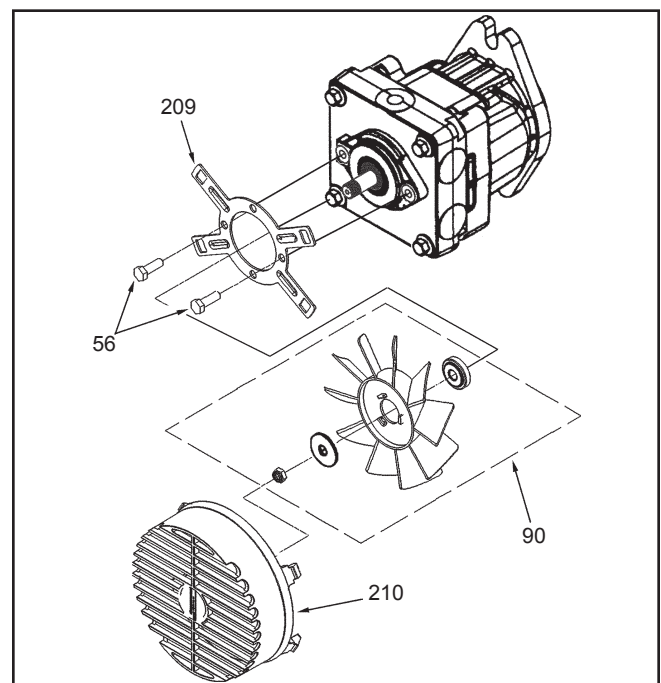

Figure 3. PW / PY Pump Fan Assembly

REMOVAL, INSPECTION AND/OR REPLACEMENT OF INPUT SHAFT SEAL

Refer to Figure 4.

Disassembly

1. Remove retaining ring (3) from housing (15).
2. Remove lip seal (6). Care must be taken to prevent damage to the housing bore, shaft, sealing surface, or bearing. Once removed, the seal is not reusable.

Inspection

1. With the lip seal (6) removed, inspect the spacer (4), shaft bearing (5) and housing (15) bore.

Assembly

1. Lubricate the new lip seal (6) with petroleum jelly.
2. Wrap the input shaft (1) with plastic wrap to prevent damage to the inner surface of the lip seal (6).
3. Slide the seal (6) over shaft (1) so that lettering on the seal (6) faces out.
4. Press the lip seal (6) into the housing (15) bore. Insure seal (6), shaft (1) or housing (15) bore do not become damaged. Remove the plastic wrap.
5. Install the retaining ring (3) into the housing (15) bore groove.

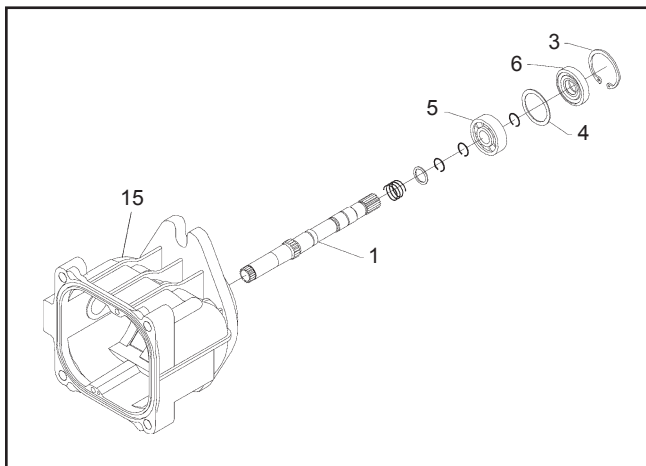

Figure 4. PW / PY Pump Input Shaft Seal

REMOVAL, INSPECTION AND/OR REPLACEMENT OF TRUNNION ARM (CONTROL ARM) SEAL

Refer to Figure 5.

Disassembly

1. Remove the retainer and lip seal (12). Care must be taken to prevent damage to the housing trunnion bore, trunnion arm (13) and sealing surface. Once removed the retainer and lip seal (12) is not reusable.

Inspection

1. With the lip seal (12) removed, inspect the area for corrosion and wear. Inspect the trunnion bore area sealing surface for damage or wear.

Assembly

1. Lubricate the new lip seal (12) with petroleum jelly.
2. Wrap the trunnion arm (13) with plastic wrap to prevent damage to the inner surface of the lip seal (12).
3. Slide the lip seal (12) over the trunnion arm (13) so that the lettering on the seal (12) faces out.
4. Press the lip seal (12) into the housing bore (15). Insure the seal (12), trunnion arm (13), and housing bore do not become damaged. Remove the plastic wrap.
5. Install the retainer over the trunnion arm (13) on top of the lip seal (12). Press into the trunnion seal bore in the housing (15).

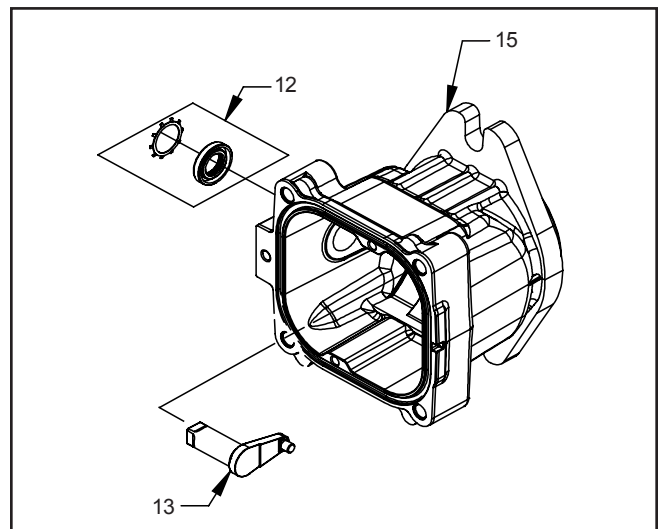

Figure 5. PW / PY Pump Trunnion Arm Seal

REMOVAL, INSPECTION AND/OR REPLACEMENT OF CHECK VALVES

Refer to Figure 6.

Disassembly

Perform disassembly, inspection and assembly on check valves one side at a time. Some units vary in “A” side to “B” side check configuration.

1. Remove the check valve (42) with an 1/4” allen wrench.
2. Remove the valve spring and poppet from the end cap (25).

Inspection

1. Inspect the poppets and mating seats in the end cap (25) for damage or foreign material.

Assembly

1. Lay the pump on its side, so the check plug port is horizontal.
2. Insert the check plug, spring and poppet (42) as one assembly into the check plug port. Tighten, reference Table 2, page 110 for torque values.
3. Repeat disassembly, inspection and assembly for the opposite port side.

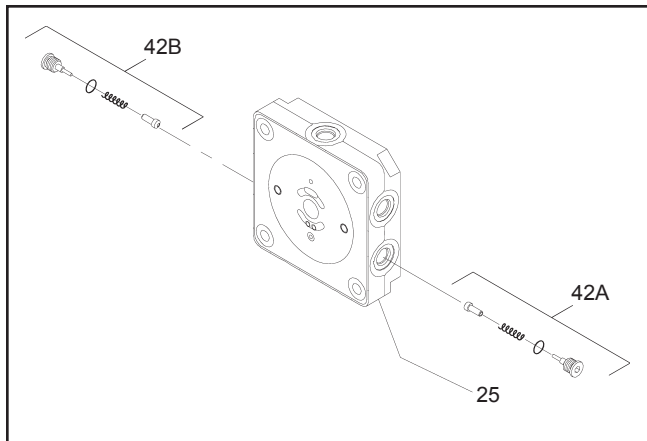

Figure 6. PW / PY Pump Check Valves

REMOVAL, INSPECTION AND/OR REPLACEMENT OF SYSTEM CHECK RELIEFS (SCR'S) OR SHOCK VALVES

Refer to Figure 7.

Disassembly

Perform disassembly, inspection and assembly on SCR/shock valve one side at a time. Some units vary in “A” side to “B” side configuration.

1. Remove the SCR (42) with a 7/8” wrench or the shock valve (42) with an 11/16” wrench.
2. Remove the check relief/shock valve spring and the check relief/shock valve from the end cap (25).

Inspection

1. Inspect the check relief or shock valve (42) and mating seat in the end cap (25) for damage or foreign material.

Assembly

1. Lay the pump on its side, so the check plug port is horizontal.
2. Insert the system check relief spring and check relief or shock valve as one assembly into the check plug port. Tighten, reference Table 2, page 110, for torque values.
3. Repeat disassembly, inspection and assembly for the opposite port side.

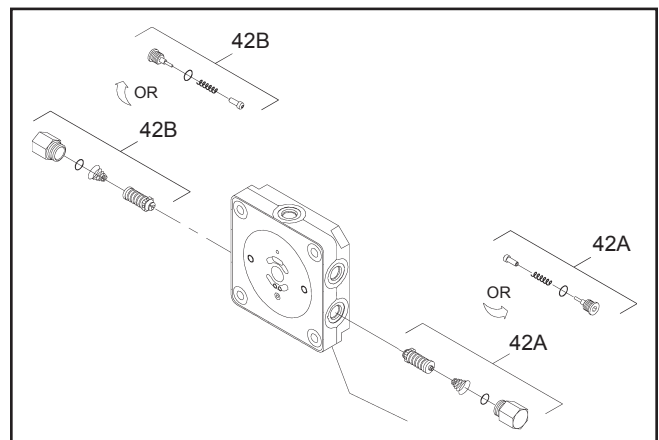

Figure 7. PW / PY Pump Shock Valves

REMOVAL, INSPECTION AND /OR REPLACEMENT OF THE BYPASS

Refer to Figure 8.

Disassembly

1. Loosen the bypass valve (50) using a 5/8" wrench.
2. Remove the bypass (50) from the end cap (25).

Inspection

1. Inspect the bypass O-rings and mating seats in the end cap (25) for damage or foreign materials.
2. If damaged or worn replace bypass (50)

Assembly

1. Lay the pump on its side, so the bypass port is horizontal.
2. Insert the bypass (50) into the bypass port on the end cap (25). Tighten, reference Table 2, page 110, torque values.

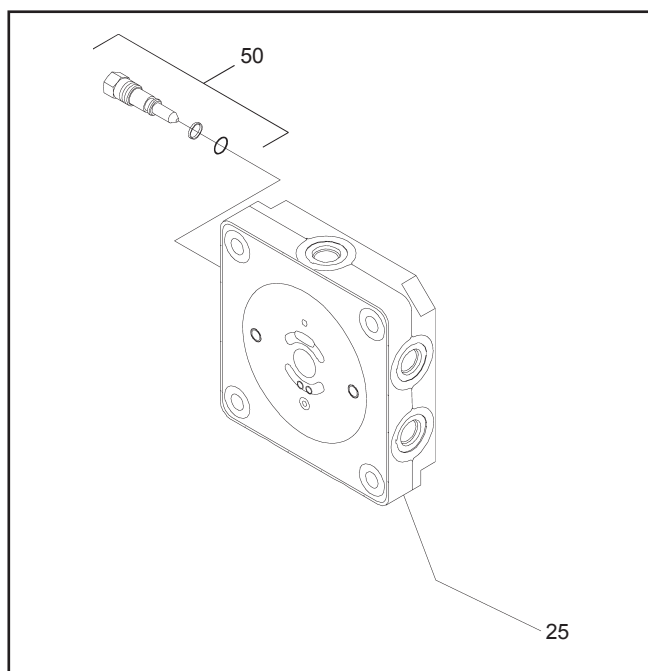

Figure 8. PW / PY Pump Bypass

REMOVAL, INSPECTION AND ASSEMBLY OF STANDARD OR THRU SHAFT CHARGE PUMP

Refer to Figure 9.

Disassembly

1. Prior to removal of the charge pump cover, place a mark on the cover and end cap for alignment at assembly.
2. Using a 1/2 inch wrench loosen the charge pump cover bolts (56) from the end cap (25). While holding the charge cover in place, remove the charge cover bolts (56).
3. Remove the charge cover, O-ring (39) and gerotor items (41). Carefully check for and remove the charge spring and charge ball (44).
4. For the thru shaft charge pump, remove the shaft seal (37). After serial date code 3076PXXXX all thru shaft charge covers will have a retaining ring (327) holding the shaft seal (37) in place.

Inspection

1. Inspect the charge cover O-ring and running surfaces for damage. Inspect the spring, check ball (44), and mating seat in the end cap (25) for damage or foreign material.
2. Inspect the charge cover bore for damage, corrosion or wear.

NOTE: If the end cap (25) is to be removed from the housing, do not assemble the charge pump (40) until the end cap is installed on the housing.

Assembly

For the Thru Shaft charge pump follow steps 1-8. For the Standard charge pump follow steps 3-8.

1. Lubricate the new shaft seal with petroleum jelly.
2. Press the shaft seal into the charge cover. Be careful not to damage the seal or charge cover bore.
3. Position the pump with the input shaft down, and the end cap (25) horizontal. Place the charge ball (44) in the end cap (25) charge passage so the ball mates to the end cap (25) charge ball seat. Place the charge spring (44), on top of the charge ball.
4. Insert the inner gerotor over input shaft.
5. Align the outer gerotor to fit over the inner gerotor.
6. Insert the O-ring (39) into the groove in the charge cover.
7. Position the charge cover and O-ring (39) with the aligning mark on the end cap (25). Place the charge cover and O-ring with aligning mark on the end cap. Place the charge cover and O-ring as one piece over the charge spring (44) and gerotor assembly. Insure the spring fits into the charge cover spring retaining groove.
8. Align and insert the charge pump cover bolts (56) into the end cap (25). Tighten to the correct torque value. See Table 2, page 110. (Torque Values.)

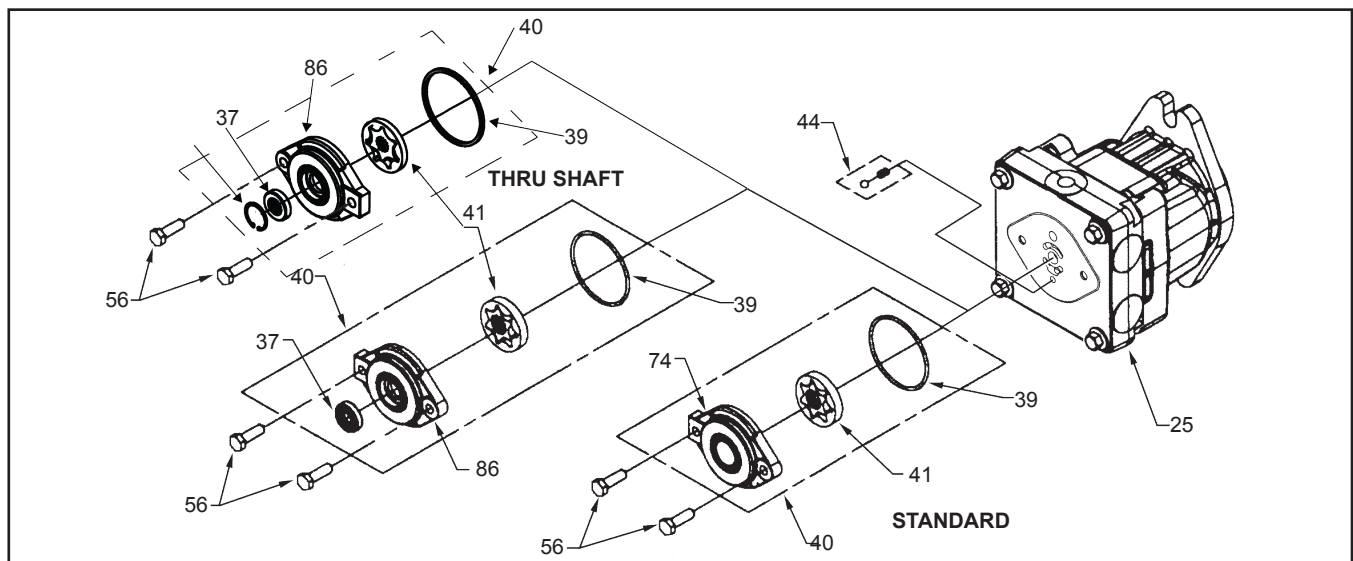

Figure 9. PW / PY Pump Standard or Thru Shaft Charge Pump

REMOVAL, INSPECTION AND/OR REPLACEMENT OF AUXILIARY PUMP (IF EQUIPPED)

Refer to Figure 10.

Disassembly

1. Prior to removal of the auxiliary pump, place a mark on the auxiliary pump, charge pump (41) and end cap (25) for alignment at assembly.
2. Use a 10mm wrench to loosen the auxiliary pump bolts (56) from the end cap (25). While holding the auxiliary pump in place, remove the bolts (56).
3. Remove the auxiliary pump, gasket, O-ring (39) and charge pump (41). While removing the charge pump, be sure to retain the spring and ball (44A) housed in the end cap (25).
4. Remove the plug (66) from the filter cover (67).
5. Use a 7/8 inch wrench to remove the filter cover assembly (67) from the pump.
6. Remove the O-ring and filter (54).
7. Remove the charge relief valve assembly (44) and auxiliary relief valve assembly (45) from the auxiliary pump.

Inspection

1. With the auxiliary pump removed, inspect the pump running surfaces for wear or damage.

2. Inspect all O-rings, gasket and mounting seats.
3. Inspect the filter cover assembly threads and filter for wear, damage or foreign material.

Assembly

1. Install the check ball, spring, and cap as one assembly (45) into the auxiliary relief valve port. Tighten to the correct torque value. See page 110.
2. Install the poppet, spring and cap as one assembly (44) into the charge relief port. Tighten to the correct torque value. See page 110.
3. Install the filter (54) and O-ring into the filter cover assembly (67). Install the assembly (67) into the auxiliary pump and tighten. Install the plug (66) into the filter cover (67).
4. Lay the PW pump (input shaft down), so the end cap is horizontal. Install the O-ring (39) into the charge pump (41).
5. Install the gasket onto the auxiliary pump.
6. Make sure that the ball and spring (44A) are seated in the end cap (25), then position the auxiliary pump and gasket with the aligning mark on the charge pump (7). Insure that the pump fully engages the alignment pins (69).
7. Align and insert the bolts (56) into the auxiliary pump. While holding the auxiliary pump and charge pump in place, tighten the bolts (56) per table 2, page 110.

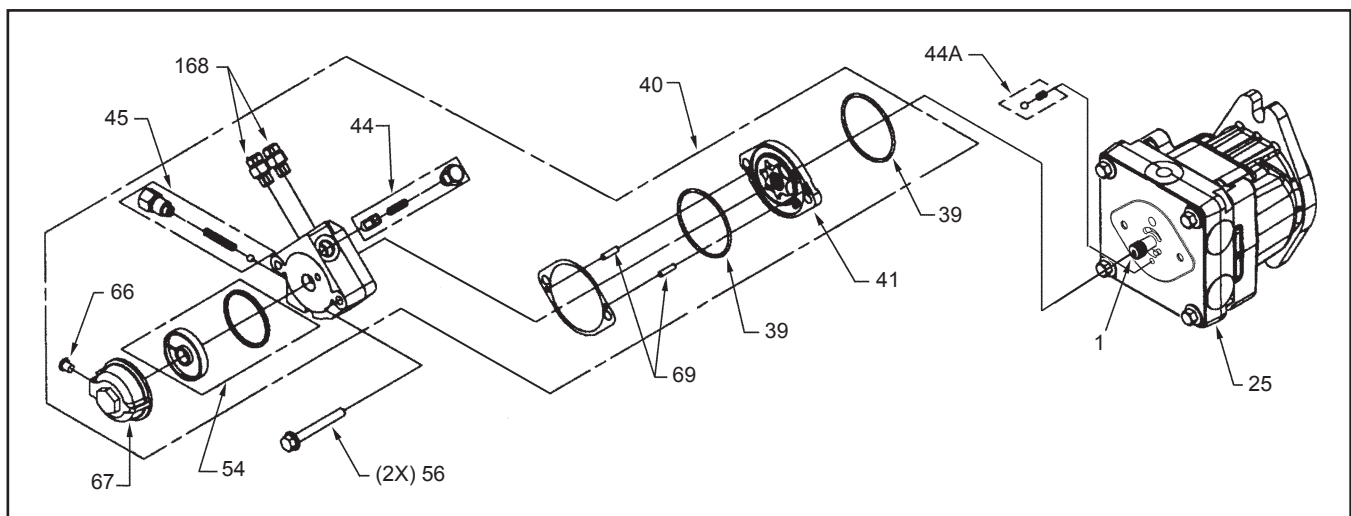

Figure 10. PW / PY Series Auxiliary Pump

REMOVAL, INSPECTION AND/OR REPLACEMENT OF 6CC PISTON AUXILIARY PUMP (IF EQUIPPED)

Refer to Figure 11.

Disassembly

1. Prior to removal of the 6cc piston auxiliary pump (40), *mark the auxiliary pump, charge pump (41) and end cap (25) for correct alignment at assembly.*
2. Remove the rotating cap (78) and O-ring (77).
3. Remove the thrust bearing (76).
4. Remove the cylinder block assembly (72-75).
5. Remove the portblock (40).
6. Remove the gerotor (41), O-ring (39), charge ball and spring (44A).
7. Remove the relief valve (70) from port block (40).

Inspection

1. Inspect bearing areas on (78) and O-ring.
2. Inspect thrust bearing (76) see page 121 figure 14.
3. Inspect cylinder block assembly (72-75) see page 120 figure 13.

4. Inspect running face on portblock (40). Grooving in the portblock, made evident when the surface is checked by dragging a fingernail across the surface, would be cause for replacement.
5. Inspect gerotor (41), O-ring (39) and end cap(25).

Assembly

1. After the endcap (25) has been installed on the pump housing (15). Position the pump with the input shaft down, and the end cap (25) horizontal. Place the charge ball (44) in the end cap (25) charge passage so the ball mates to the end cap (25) charge ball seat. Place the charge spring (44), on top of the charge ball.
2. Insert the gerotor (41) over input shaft.
3. Install the portblock (40) *paying attention to the orientation marks made before disassembly.* Tighten to the correct torque value. See Table 2, page 110. (Torque Values.)
4. Install cylinder block.
5. Install the rotating cap (78). Tighten to the correct torque value. See Table 2, page 110. (Torque Values.)

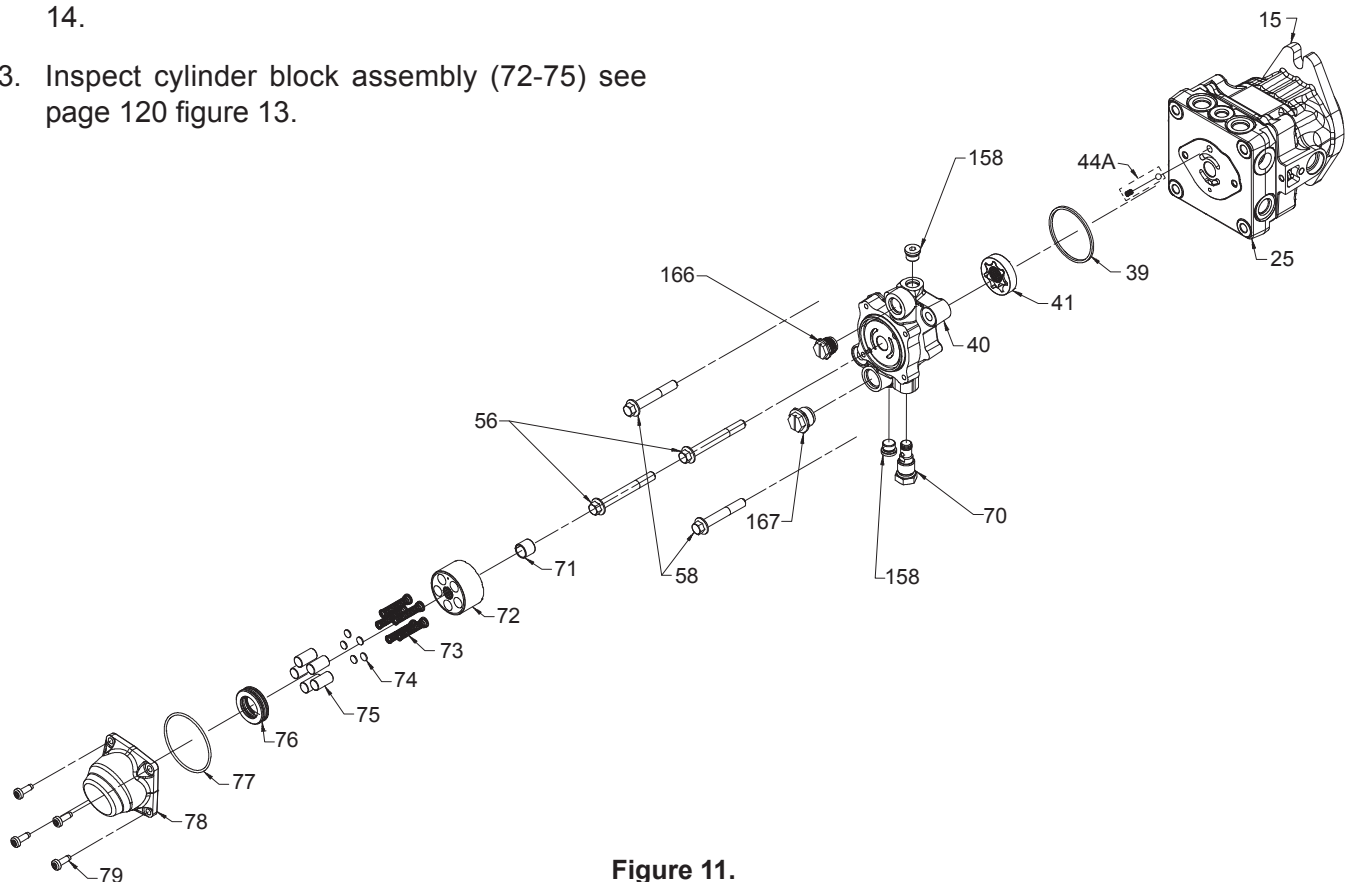

Figure 11.

REMOVAL, INSPECTION AND ASSEMBLY OF THE END CAP AND VALVE PLATE

Refer to Figure 12.

Disassembly

1. Using any combination of two, 9/16" wrenches or 9/16" socket and ratchet drive, loosen the end cap bolts (58) evenly.
2. Keeping the end cap (25) held in place, remove the four end cap bolts (58).
3. Slowly remove the end cap (25).
4. Remove the valve plate (29).

NOTE: This step is only applicable on PW series pumps built prior to 0216Pxxxxx.

5. Remove housing alignment pins (26).
6. Remove housing gasket (28).

Inspection

1. Inspect the end cap (25) and/or valve plate (29) for damage, nicks or unusual wear patterns.

NOTE: Grooving in the valve plate and/or end cap, made evident when the surface is checked by dragging a fingernail across the surface, would be cause for replacement of the valve plate and/or end cap.

2. Inspect and replace alignment pins (26) if bent or distorted.
3. Replace the housing O-ring (28) with a new O-ring before reassembly.

Assembly

1. Install housing O-ring (28) into O-ring seat of housing (15).
2. Install alignment pins (26) into housing (15).
3. Lubricate the valve plate prior to installation. Install valve plate (29) with the bronze side down, contacting the cylinder block.

NOTE: This step is only applicable on PW series pumps built prior to 0216Pxxxxx.

4. On pumps built without a valve plate, lubricate the end cap prior to installation.
5. Install end cap (25). Before installing the four end cap bolts (58), push down on the end cap (25) verifying alignment and insuring that the cylinder block pistons spring back and forth. Install end cap bolts. Tighten, per Table 2, page 110, torque values.

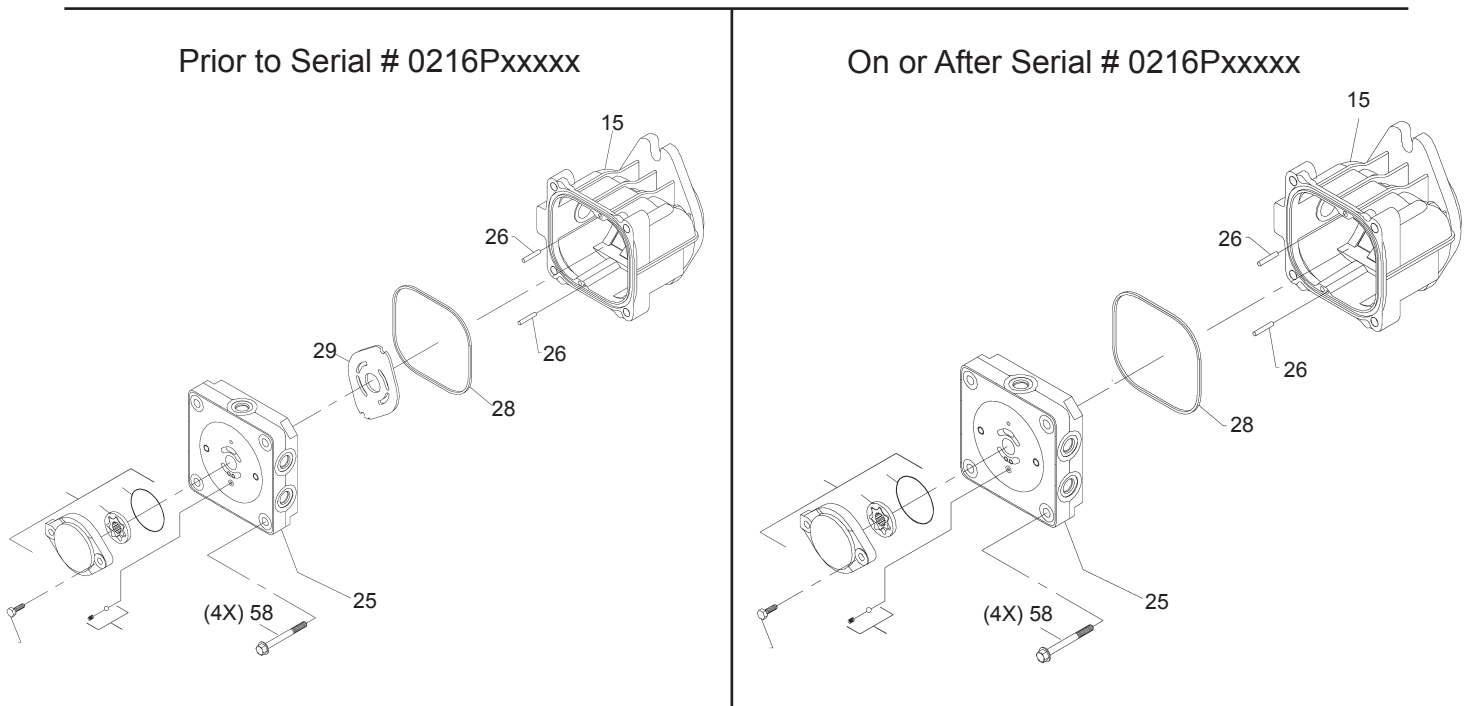

Figure 12. PW / PY Pump End Cap

REMOVAL, INSPECTION AND ASSEMBLY OF THE CYLINDER BLOCK

Refer to Figure 13.

Disassembly

1. Tilt the pump on its side, drain remaining oil. Lift out the cylinder block assembly (38).
2. Remove the pistons, springs and piston seats.

Inspection

1. Inspect the running surface of the cylinder block and piston ends for damage, nicks or unusual wear patterns.

The running surface may show evidence of minor abrasion. This will be normal wear. If grooved or smeared, replace with a new cylinder block assembly.

2. Inspect the piston springs for distortion or breakage. If necessary, replace with a new cylinder block kit.
3. Inspect the piston seats. Residual oil may cause these to remain stuck to the inside of the pistons.

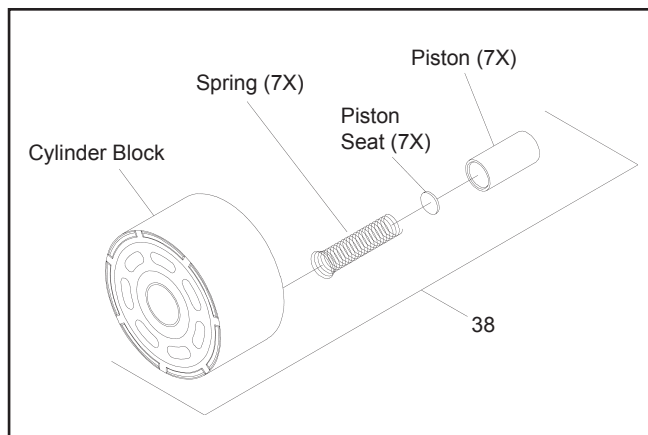

Figure 13. PW / PY Pump Cylinder Block

Assembly

1. Install piston seats into the end of the pistons.
2. Install springs into the pistons.
3. Install one at a time, pistons, springs and seats as one assembly into the cylinder block.
4. With the pump housing tilted on its side, install the cylinder block assembly (38) with pistons contacting the thrust bearing.

NOTE: To check that piston placement is correct, push downward on the cylinder block assembly (38). If this results in a spring action the block assembly has been installed correctly. If this cannot be accomplished, remove and reassemble the block assembly. Place a rubber band around the cylinder block pistons to hold them in position during installation. Then after installation cut the rubber band and remove it. Check for cylinder block assembly for spring action.

REMOVAL, INSPECTION AND ASSEMBLY OF THRUST BEARING

Refer to Figure 14.

Disassembly

1. Remove the thrust bearing and race (17).

Inspection

1. Inspect the running surface of the bearing race for damage (17), nicks or unusual wear patterns. The running surface may show evidence of minor abrasion. This will be normal wear. Inspect the bearings for free movement. Inspect the bearing cage for distortion or damage. Replace if necessary.

Assembly

1. Install thrust bearing and race assembly (17).

NOTE: The difference in race thicknesses: The thin race seats into the swashplate. The thicker race will be installed toward the piston noses.

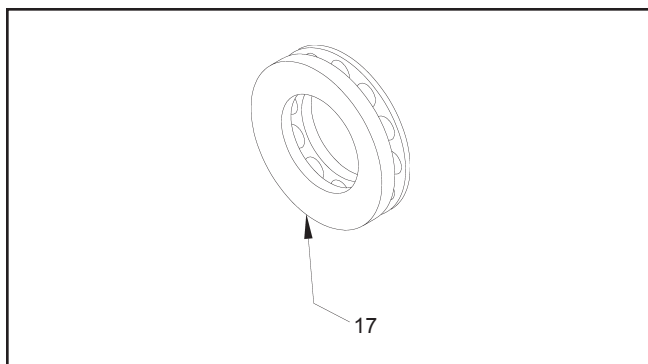

Figure 14. PW / PY Pump Thrust Bearing

REMOVAL, INSPECTION AND ASSEMBLY OF SWASHPLATE AND CRADLE BEARINGS

Refer to Figure 15.

Disassembly

1. Remove the swashplate (31).

Inspection

1. Inspect the running surface of the bearing pocket for damage (31), nicks or unusual wear patterns. The running surface may show evidence of minor abrasion. This is normal wear. Inspect the cradle bearing side of the swashplate (31) for damage. Replace if necessary.
2. Inspect the cradle bearings attached to the inside of the housing (15) for normal wear patterns, placement, and insure they are staked in place. If damaged, replace housing (15).

NOTE: The cradle bearings will have discoloration due to normal wear. Under normal circumstances, this will not warrant replacement.

Assembly

1. Install swashplate (31) by holding trunnion arm's (13) slot guide (14) with a flat tip screwdriver. Use the screwdriver to hold the slot guide (14) in place while positioning the swashplate (31) onto the cradle bearing in the housing (15).
2. Rotate trunnion arm (13) to assure swashplate pivoting action.

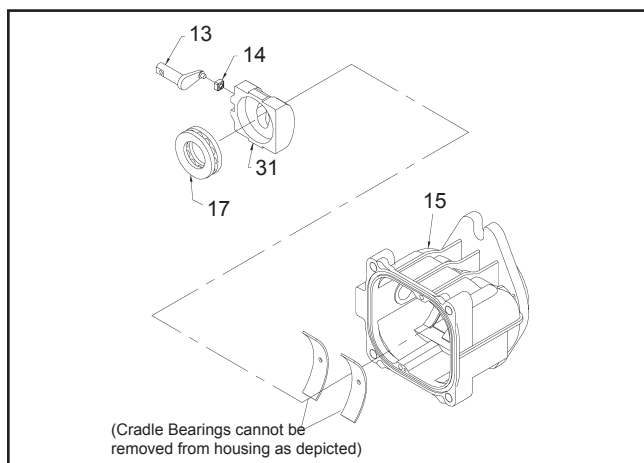

Figure 15. PW / PY Pump Swashplate and Cradle Bearings

REMOVAL, INSPECTION AND ASSEMBLY OF INPUT SHAFT

Refer to Figure 16.

Disassembly

1. Remove the retaining ring (3).
2. Remove the lip seal (6).
3. Remove the spacer (4).
4. Remove the shaft assembly (1).

Inspection

1. Inspect the input shaft (1) for worn splines, damage, or keyway damage. Replace shaft assembly if necessary.
2. Inspect the bearing (5) for evidence of scoring, corrosion, or damage. Replace shaft assembly if necessary.
3. Inspect and replace the spacer (4) if it is bent or broken.

NOTE: Replace the input shaft seal (6) after removal.

4. Inspect and replace the retaining ring (3) if it is bent or broken.

NOTE: If trunnion arm is to be removed, delay reassembly of input shaft assembly.

5. Inspect and replace the thrust spring (20) and thrust washer (19) if they are distorted or broken.

Assembly

NOTE: Upon removal, it is recommended that all seals, O-rings and gaskets be replaced. During installation, lightly lubricate all seals, O-rings and gaskets with clean petroleum jelly prior to assembly. Also, protect the inner diameter of seals by covering the shaft with plastic wrap.

1. Install input shaft (1) assembly into the housing (15) bore. Light tapping with a rubber mallet may be necessary on the input shaft (1) once the bearing is aligned with the housing bore (15). Rotate the input shaft (1) to insure free movement.
2. Install spacer (4).
3. Install new lip seal (6). Remove the plastic wrap.
4. Install retaining ring (3).

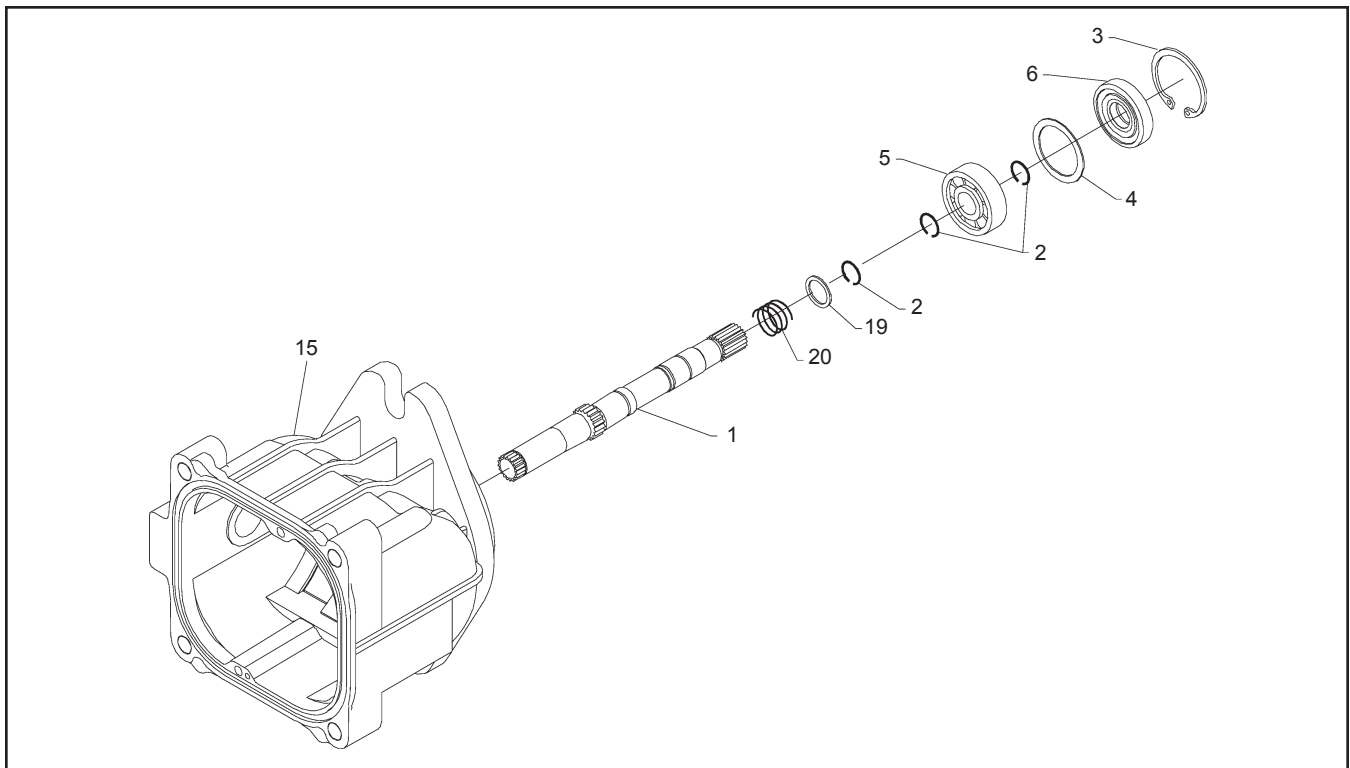

Figure 16. PW / PY Pump Input Shaft

REMOVAL AND INSPECTION OF TRUNNION ARM

Refer to Figure 17.

Disassembly

1. Remove trunnion seal retainer and seal (12).
2. Remove the slot guide (14).
3. Remove the trunnion arm (13).

Inspection

1. Inspect the trunnion arm (13) for wear or damage. Replace the trunnion arm if necessary.

Assembly

1. Install the trunnion arm (13) into the housing (15) bore. Rotate the trunnion arm to verify free movement.

NOTE: Upon removal, it is recommended that all seals, O-rings, and gaskets be replaced. During installation, lightly lubricate all seals, O-rings and gaskets with clean petroleum jelly prior to assembly. Also protect the inner diameter of seals by covering the shaft with plastic wrap. Remove the plastic wrap after the seal is installed.

2. Install a new seal and seal retainer.
3. Install the slot guide (14).
4. To completely reassemble the pump, refer to the assembly steps on pages 111-122. Begin with the trunnion arm assembly steps listed on page 122 and complete the assembly steps in reverse order working towards the front of the manual.

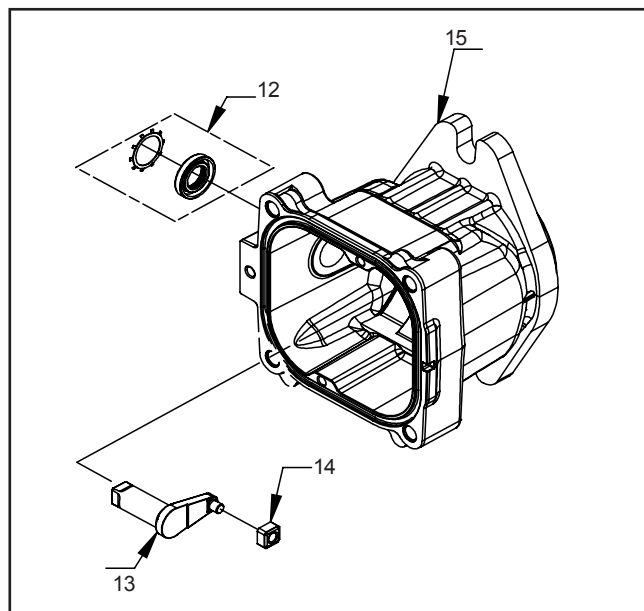
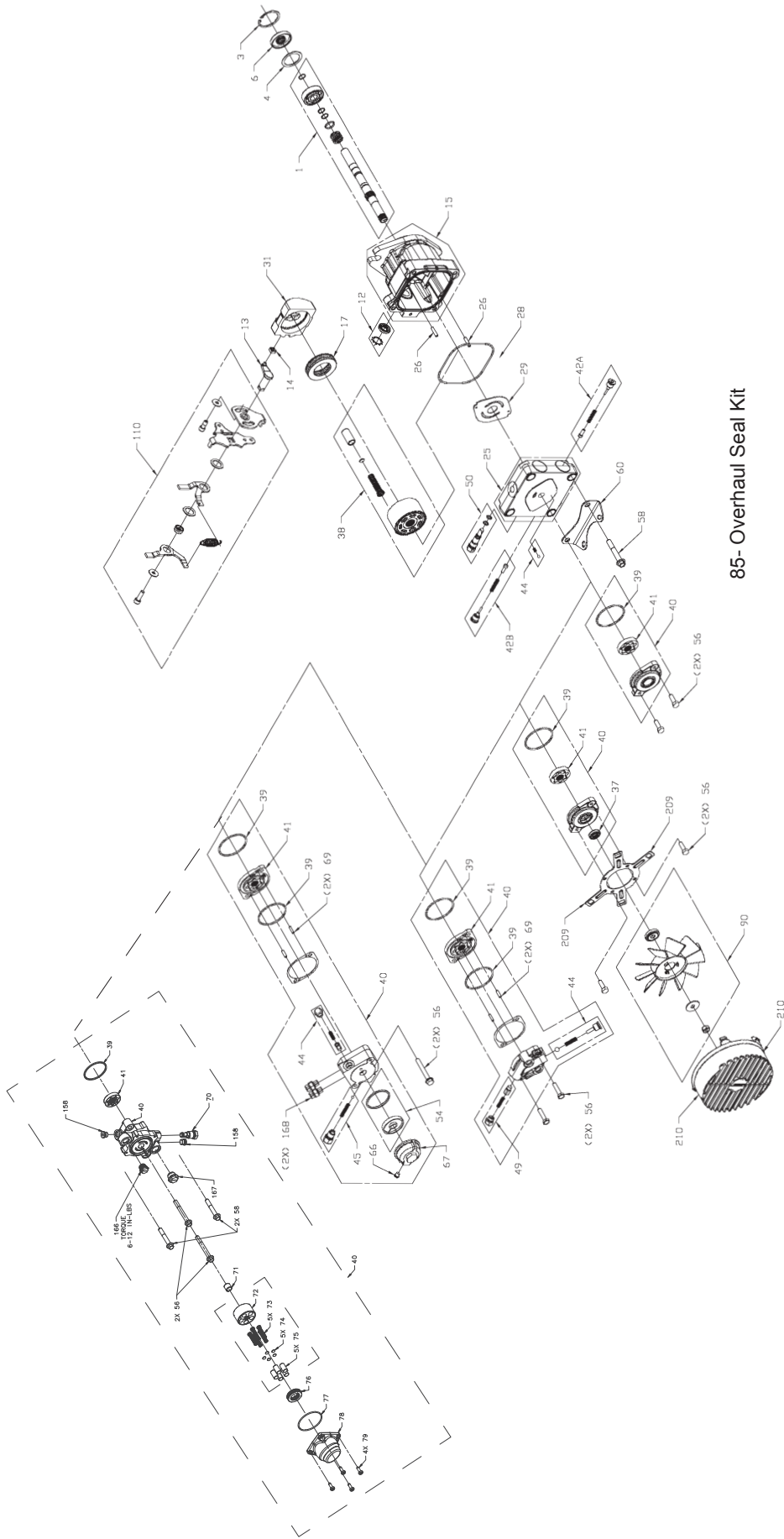

Figure 17. PW / PY Pump Trunnion Arm



85- Overhaul Seal Kit

Kit Number

BOXES INDICATE ITEMS INCLUDED IN KITS.

Figure 17. PW / PY Pump

ITEM LIST - PW / PY SERIES

Part numbers are not provided in this manual.

No.	Description	No.	Description
1	Pump Shaft Kit (19T spline)		Charge Pump Kit (AL Aux, 7/16 SAE port, 75-105 psi)
	Pump Shaft Kit (closed key)		Charge Pump Kit (6cc Aux)
	Pump Shaft Kit (thru shaft spline)	41	Gerotor Assembly (0.19 in ³ /rev)
	Pump Shaft Kit (tapered thru shaft)		Aux Gerotor & HSG Assembly (0.19 in ³ /rev)
	Pump Shaft Kit (shaft - thru pump)		Gerotor Assembly (0.13 in ³ /rev)
	Retaining Ring	42	Check Valve Kit (.031")
4	Spacer		Check Valve Kit (.044")
5	Shaft Ball Bearing		Shock Valve Kit (blank)
6	Lip Seal 17 X 47 X 8 PTCN1		System Check/Relief Kit
10	Trunnion Seal Retaining Ring	44	Charge Relief Kit (w 1/2" SAE valve plug, 40-70 psi)
12	Lip Seal 15 X 27 X 7		Charge Relief Kit (w 1/2" SAE valve plug, 135-165 psi)
13	Trunnion Arm		Charge Relief Kit (w/ 9/16" SAE valve plug)
14	Slot Guide		Charge Relief Kit (w/ 9/16" SAE valve plug 75-105 psi)
15	Housing Kit		Charge Relief Kit (w/ 7/32" plastic ball & spring)
17	Thrust Ball Bearing Assembly		Charge Relief Kit (w/ 1/4" plastic ball & spring)
19	Block Thrust Washer	45	Aux Relief Valve Kit
20	Block Spring	49	Aux Bypass/Check Kit
25	End Cap Kit (w/poppets)	50	Bypass Valve Kit (blank)
	End Cap Kit (w/poppets , .078" cooling orifice)		Bypass Valve Kit (.031")
	End Cap Kit (w SCR'S)	54	Auxiliary Filter Kit
	End Cap Kit (Aux w/ poppets)	56	Hex Screw, 5/16 - 18 X 1.0
	End Cap Kit (Aux w/ SCR's)		Hex Hd Cap Screw, 5/16 - 18 X 2.5
	End Cap Kit (Aux w/ LH:SCR and RH:poppet)	58	Hex Screw, Flanged Head
	End Cap Kit (w/LH:poppet and RH:SCR)	59	Hex Flange Nut
26	Pin	60	Mounting Bracket
28	O-Ring	66	Plug
29	Valve Plate	67	Filter Cover
31	Variable Swashplate	69	Pin
38	Cylinder Block Kit	85	Overhaul Seal Kit
39	O-Ring	110	Return Kit
	R-Ring (-144)	168	Connector
40	Charge Pump Kit (0.19 std splined)	209	Shroud Bracket
	Charge Pump Kit (0.13 std splined)	210	Shroud
	Charge Pump Kit (0.13 std thru shaft)		
	Charge Pump Kit (0.13 std spline, clear zinc cover)		
	Charge Pump Kit (CW - splined Aux, 40-70 psi)		
	Charge Pump Kit (CW - splined Aux, 135-165 psi)		
	Charge Pump Kit (CCW - splined Aux, 40-70 psi)		
	Charge Pump Kit (AL Aux, 7/16 SAE port, 40-70 psi)		

GLOSSARY OF TERMS

Axial Piston: Type of design for hydraulic motors and pumps in which the pistons are arranged parallel with the spindle (input or output shaft).

Bypass Valve: A valve whose primary function is to open a path for the fluid to bypass the motor or pump. Also referred to occasionally as the freewheel valve or dump valve.

Case Drain Line (Return Line): A line returning fluid from the component housing to the reservoir.

Cavitation: A phenomenon of boiling in a flowing liquid at normal temperatures, as a result of low pressure condition. The gas liberated from the fluid implodes rapidly and damages pump components.

Center Section: A device which acts as the valve body and manifold of the transmission.

Charge Pump: A device which supplies replenishing fluid to the fluid power system (closed loop).

Charge Pressure: The pressure at which replenishing fluid is forced into a fluid power system.

Charge Relief Valve: A pressure control valve whose primary function is to limit pressure in the charge circuit.

Check Valve: A valve whose primary function is to restrict flow in one direction.

Closed Loop: A sealed and uninterrupted circulating path for fluid flow from the pump to the motor and back.

Decay Rate: The ratio of pressure decay over time.

End Cap: See “Center Section.”

Entrained Air: A mechanically generated mixture of air bubbles having a tendency to separate from the liquid phase.

Gerotor: A fixed displacement pump frequently used as a charge pump.

Hydraulic Motor: A device which converts hydraulic fluid pressure and flow into mechanical force and motion.

Hydraulic Pump: A device which converts mechanical force and motion into hydraulic fluid pressure and flow.

Hydrostatic Motor: See “Hydraulic Motor.”

Hydrostatic Pump: See “Hydraulic Pump.”

Hydrostatic Transaxle: A multicomponent assembly including a gear case and a hydrostatic transmission.

Hydrostatic Transmission: The combination of a hydraulic pump and motor in one housing to form a device for the control and transfer of power.

Inlet Line: A supply line to the pump.

Integrated Hydrostatic Transaxle (IHT): The combination of a hydrostatic transmission and gear case in one housing to form a complete transaxle.

Manifold: A conductor which provides multiple connection ports.

Neutral: Typically described as a condition in which fluid flow and system pressure are below that which is required to turn the output shaft of the motor.

Pressure Decay: A falling pressure.

Priming: The filling of the charge circuit and closed loop of the fluid power system during start-up, frequently achieved by pressurizing the fluid in the inlet line.

Purging: The act of replacing air with fluid in a fluid power system.

Rated Flow: The maximum flow that the pump is capable of supplying.

Scoring: Scratches in the direction of motion of mechanical parts caused by abrasive contaminants.

Shock Valve: A relief valve in the closed loop of the hydrostatic circuit that provides makeup oil, as well as protecting the circuit from high pressure shocks or spikes.

Swashplate: A mechanical device used to control the displacement of the pump pistons in a fluid power system.

System Charge Check Valve: A valve controlling the replenishing flow of fluid from a charge circuit to the closed loop in a fluid power system.

System Pressure: The pressure which overcomes the total resistance in a system, including all efficiency losses.

Valve: A device which controls fluid flow direction, pressure, or flow rate.

Variable Displacement Pump: A pump in which the displacement per revolution can be varied.

Volumetric Displacement: The fluid volume for one revolution.

