

**TORO**<sup>®</sup>

Consumer Products

# **LX Lawn Tractor**

## **Service Manual**





# TABLE OF CONTENTS

SAFETY INFORMATION	
General Information . . . . .	1-1
Think Safety First . . . . .	1-1
SPECIFICATIONS	
Torque Specifications . . . . .	2-1
Standard Torque for Dry, Zinc Plated and Steel Fasteners (Inch Series) . . . . .	2-2
Standard Torque for Dry, Zinc and Steel Fasteners (Metric Fasteners) . . . . .	2-3
Other Torque Specifications . . . . .	2-4
Equivalents and Conversions . . . . .	2-5
Product Specifications . . . . .	2-6
CHASSIS	
Front Pivot Axle Replacement	
Removal . . . . .	3-1
Installation . . . . .	3-7
Axle Assembly Replacement	
Removal . . . . .	3-14
Installation . . . . .	3-17
Steering Wheel Replacement	
Removal . . . . .	3-19
Installation . . . . .	3-20
Steering Shaft Replacement	
Removal . . . . .	3-21
Installation . . . . .	3-24
Electric PTO Clutch Replacement	
Removal . . . . .	3-27
Installation . . . . .	3-28
Fuel Tank Replacement	
Removal . . . . .	3-29
Installation . . . . .	3-30
Hood Replacement	
Removal . . . . .	3-31
Installation . . . . .	3-32
Fender Replacement	
Removal . . . . .	3-33
Installation . . . . .	3-39
Tower Replacement	
Removal . . . . .	3-45
Installation . . . . .	3-53
Lower Transmission Drive Belt Replacement - Gear Drive Models	
Removal . . . . .	3-62
Installation . . . . .	3-64
Upper Transmission Drive Belt Replacement - Gear Drive Models	
Removal . . . . .	3-67
Installation . . . . .	3-69
Transmission Drive Belt (Hydro) Replacement	
Removal . . . . .	3-71
Installation . . . . .	3-74
Variable Speed Pulley Replacement	
Removal . . . . .	3-77
Installation . . . . .	3-79

# TABLE OF CONTENTS

---

## CHASSIS cont.

Variable Speed Pulley Service	
Disassembly . . . . .	3-81
Assembly . . . . .	3-82
Purging the System - Hydrostatic Models . . . . .	3-82
Fluid Change - Hydrostatic Models . . . . .	3-83
Neutral Adjustment - Hydrostatic Models . . . . .	3-84
Front Wheel Toe-in Measurement . . . . .	3-85
Front Wheel Toe-in Adjustment . . . . .	3-86
Autodrive Pedal Adjustment - Hydrostatic Models . . . . .	3-87
Brake Adjustment - Hydrostatic Models . . . . .	3-91
Throttle/Choke Cable Replacement	
Removal . . . . .	3-93
Installation . . . . .	3-96

## ENGINE

Engine Replacement	
Removal . . . . .	4-1
Installation . . . . .	4-7

## GEAR DRIVE SYSTEM

CVT Transmission Replacement	
Removal . . . . .	5-1
Installation . . . . .	5-4
Brake Puck Replacement	
Removal . . . . .	5-9
Installation . . . . .	5-11
Brake Adjustment . . . . .	5-14

## HYDROSTATIC DRIVE SYSTEM

Hydro Transmission Replacement	
Removal . . . . .	6-1
Installation . . . . .	6-7

## MOWER DECK

42" Mower Deck - Brake Idler Assembly Replacement	
Removal . . . . .	7-1
Installation . . . . .	7-3
42" Mower Deck - Idler Assembly Replacement	
Removal . . . . .	7-6
Installation . . . . .	7-8
42" Mower Belt Replacement	
Removal . . . . .	7-11
Installation . . . . .	7-13
46" Mower Deck - RH Idler Bracket Assembly	
Removal . . . . .	7-14
Installation . . . . .	7-16
46" Mower Deck - Brake Assembly	
Removal . . . . .	7-19
Installation . . . . .	7-20
46" Mower Deck - LH Idler Assembly	
Removal . . . . .	7-21
Installation . . . . .	7-23

# TABLE OF CONTENTS

## MOWER DECK cont.

46" Mower Deck - Lower Idler Bracket	
Removal . . . . .	7-25
Installation . . . . .	7-26
46" Mower Deck - Lower Mower Deck Belt Replacement	
Removal . . . . .	7-27
Installation . . . . .	7-30
46" Mower Deck - Upper Mower Deck Belt Replacement	
Removal . . . . .	7-34
Installation . . . . .	7-35
50" Mower Deck - Belt Replacement	
Removal . . . . .	7-36
Installation . . . . .	7-38
50" Mower Deck - Idler Replacement	
Removal . . . . .	7-39
Installation . . . . .	7-41
42" Mower Deck - Spindle Replacement	
Removal . . . . .	7-43
Installation . . . . .	7-45
42" Mower Deck - Spindle Service . . . . .	7-47
46" Mower Deck - Double Pulley Spindle Service . . . . .	7-51
46" Mower Deck - Single Pulley Spindle Service . . . . .	7-56
50" Mower Deck - Spindle Service . . . . .	7-60
42" Mower Deck Removal . . . . .	7-64
42" Mower Deck Installation . . . . .	7-67
46" Mower Deck Removal . . . . .	7-69
46" Mower Deck Installation . . . . .	7-72
50" Mower Deck Removal . . . . .	7-74
50" Mower Deck Installation . . . . .	7-76

## ELECTRICAL

Electrical System . . . . .	8-1
-----------------------------	-----

# **TABLE OF CONTENTS**

---

**THIS PAGE INTENTIONALLY LEFT BLANK.**

## General Information



This symbol means WARNING or PERSONAL SAFETY INSTRUCTION - read the instruction because it has to do with your safety. Failure to comply with the instruction may result in personal injury or even death.

This manual is intended as a service and repair manual only. The safety instructions provided herein are for troubleshooting, service, and repair of the LX Series Riding Lawn Tractor.

The riding mower and attachment operator's manual contain safety information and operating tips for safe operating practices. Operator's manuals are available through your Toro parts source or:

**The Toro Company  
Publications Department  
8111 Lyndale Avenue South  
Bloomington, MN 55420**

## Think Safety First

### **Avoid unexpected starting of engine...**

Always turn off the engine and disconnect the spark plug wire(s) before cleaning, adjusting, or repair.

### **Avoid lacerations and amputations...**

Stay clear of all moving parts whenever the engine is running. Treat all normally moving parts as if they were moving whenever the engine is running or has the potential to start.

### **Avoid burns...**

Do not touch the engine, muffler, or other components which may increase in temperature during operation, while the unit is running or shortly after it has been running.

### **Avoid fires and explosions...**

Avoid spilling fuel and never smoke while working with any type of fuel or lubricant. Wipe up any spilled fuel or oil immediately. Never remove the fuel cap or add fuel when the engine is running. Always use approved, labeled containers for storing or transporting fuel and lubricants.

### **Avoid asphyxiation...**

Never operate an engine in a confined area without proper ventilation.

### **Avoid injury from batteries...**

Battery acid is poisonous and can cause burns. Avoid contact with skin, eyes, and clothing. Battery gases can explode. Keep cigarettes, sparks, and flames away from the battery.

### **Avoid injury due to inferior parts...**

Use only original equipment parts to ensure that important safety criteria are met.

### **Avoid injury to bystanders...**

Always clear the area of bystanders before starting or testing powered equipment.

### **Avoid injury due to projectiles...**

Always clear the area of sticks, rocks, or any other debris that could be picked up and thrown by the powered equipment.

### **Avoid modifications...**

Never alter or modify any part unless it is a factory approved procedure.

### **Avoid unsafe operation...**

Always test the safety interlock system after making adjustments or repairs on the machine. Refer to the Electrical section in this manual for more information.

# SAFETY INFORMATION

---

**1**

**THIS PAGE INTENTIONALLY LEFT BLANK.**



# SPECIFICATIONS

## Torque Specifications

Recommended fastener torque values are listed in the following tables. For critical applications, as determined by Toro, either the recommended torque or a torque that is unique to the application is clearly identified and specified in the service manual.

These torque specifications for the installation and tightening of fasteners shall apply to all fasteners which do not have a specific requirement identified in the service manual. The following factors shall be considered when applying torque: cleanliness of the fastener, use of a thread sealant (Loctite), degree of lubrication on the fastener, presence of a prevailing torque feature, hardness of the surface underneath of the fastener's head, or similar condition which affects the installation.

As noted in the following tables, torque values should be **reduced by 25% for lubricated fasteners** to achieve the similar stress as a dry fastener. Torque values may also have to be reduced when the fastener is threaded into aluminum or brass. The specific torque value should be determined based on the aluminum or brass material strength, fastener size, length of thread engagement, etc.

The standard method of verifying torque shall be performed by marking a line on the fastener (head or nut) and mating part, then back off fastener 1/4 of a turn. Measure the torque required to tighten the fastener until the lines match up.

## Fastener Identification

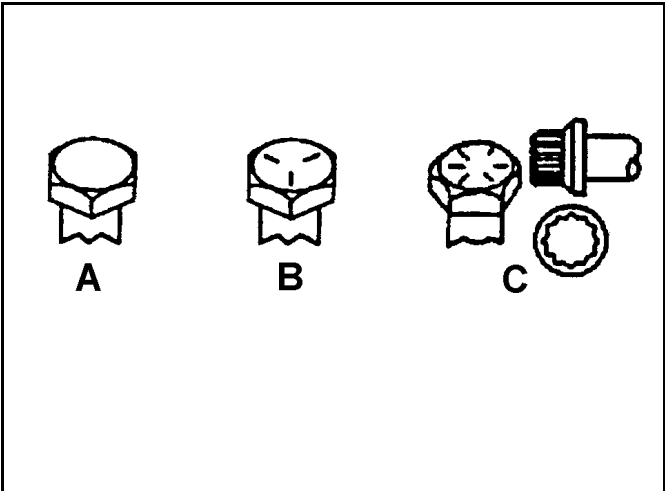

Figure 1

Inch Series Bolts and Screws	
(A) Grade 1	(C) Grade 8
(B) Grade 5	

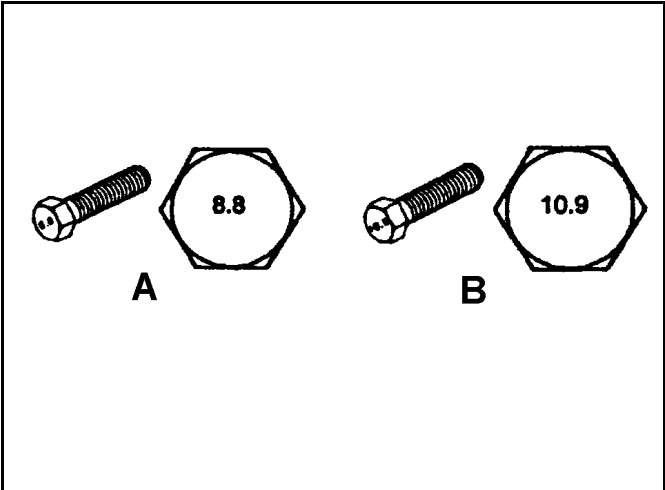

Figure 2

Metric Bolts and Screws	
(A) Class 8.8	(B) Class 10.9

# SPECIFICATIONS

## Standard Torque for Dry, Zinc Plated, and Steel Fasteners (Inch Series)

Thread Size	Grade 1, 5, & 8 with Thin Height Nuts	SAE Grade 1 Bolts, Screws, Studs, & Sems with Regular Height Nuts (SAE J995 Grade 2 or Stronger Nuts)		SAE Grade 5 Bolts, Screws, Studs, & Sems with Regular Height Nuts (SAE J995 Grade 2 or Stronger Nuts)		SAE Grade 8 Bolts, Screws, Studs, & Sems with Regular Height Nuts (SAE J995 Grade 2 or Stronger Nuts)	
		In-lb	In-lb	N-cm	In-lb	N-cm	In-lb
# 6 - 32 UNC	10 ± 2	13 ± 2	147 ± 23	15 ± 2	170 ± 20	23 ± 2	260 ± 20
# 6 - 40 UNF				17 ± 2	190 ± 20	25 ± 2	280 ± 20
# 8 - 32 UNC	13 ± 2	25 ± 5	282 ± 30	29 ± 3	330 ± 30	41 ± 4	460 ± 45
# 8 - 36 UNF				31 ± 3	350 ± 30	43 ± 4	31 ± 3
# 10 - 24 UNC	18 ± 2	30 ± 5	339 ± 56	42 ± 4	475 ± 45	60 ± 6	674 ± 70
#10 - 32 UNF				48 ± 4	540 ± 45	68 ± 6	765 ± 70
1/4 - 20 UNC	48 ± 7	53 ± 7	599 ± 79	100 ± 10	1125 ± 100	140 ± 15	1580 ± 170
1/4 - 28 UNF	53 ± 7	65 ± 10	734 ± 113	115 ± 10	1300 ± 100	160 ± 15	1800 ± 170
5/16 - 18 UNC	115 ± 15	105 ± 17	1186 ± 169	200 ± 25	2250 ± 280	300 ± 30	3390 ± 340
5/16 - 24 UNF	138 ± 17	128 ± 17	1446 ± 192	225 ± 25	2540 ± 280	325 ± 30	3670 ± 340
	ft-lb	ft-lb	N-m	ft-lb	N-m	ft-lb	N-m
3/8 - 16 UNC	16 ± 2	16 ± 2	22 ± 3	30 ± 3	41 ± 4	43 ± 4	58 ± 5
3/8 - 24 UNF	17 ± 2	18 ± 2	24 ± 3	35 ± 3	47 ± 4	50 ± 4	68 ± 5
7/16 - 14 UNC	27 ± 3	27 ± 3	37 ± 4	50 ± 5	68 ± 7	70 ± 7	68 ± 9
7/16 - 20 UNF	29 ± 3	29 ± 3	39 ± 4	55 ± 5	75 ± 7	77 ± 7	104 ± 9
1/2 - 13 UNC	30 ± 3	48 ± 7	65 ± 9	75 ± 8	102 ± 11	105 ± 10	142 ± 14
1/2 - 20 UNF	32 ± 3	53 ± 7	72 ± 9	85 ± 8	115 ± 11	120 ± 10	163 ± 14
5/8 - 11 UNC	65 ± 10	88 ± 12	119 ± 16	150 ± 15	203 ± 20	210 ± 20	285 ± 27
5/8 - 18 UNF	75 ± 10	95 ± 15	129 ± 20	170 ± 15	230 ± 20	240 ± 20	325 ± 27
3/4 - 10 UNC	93 ± 12	140 ± 20	190 ± 27	265 ± 25	359 ± 34	374 ± 35	508 ± 47
3/4 - 16 UNF	115 ± 15	165 ± 25	224 ± 34	300 ± 25	407 ± 34	420 ± 35	569 ± 47
7/8 - 9 UNC	140 ± 20	225 ± 25	305 ± 34	430 ± 45	583 ± 61	600 ± 60	813 ± 81
7/8 - 14 UNF	155 ± 25	260 ± 30	353 ± 41	475 ± 45	644 ± 61	660 ± 60	895 ± 81

**Note:** Reduce torque values listed in the table above by 25% for lubricated fasteners. Lubricated fasteners are defined as threads coated with a lubricant such as oil, graphite, or thread sealant such as Loctite.

**Note:** Torque values may have to be reduced when installing fasteners into threaded aluminum or brass. The specific torque value should be determined based on the fastener size, the aluminum or base material strength, length of thread engagement, etc.

**Note:** The nominal torque values listed above for Grade 5 and 8 fasteners are based on 75% of the minimum proof load specified in SAE J429. The tolerance is approximately ± 10% of the nominal torque value. Thin height nuts include jam nuts.

# SPECIFICATIONS

2

## Standard Torque for Dry, Zinc, and Steel Fasteners (Metric Fasteners)

Thread Size	Class 8.8 Bolts, Screws, and Studs with Regular Height Nuts (Class 8 or Strong Nuts)		Class 10.9 Bolts, Screws, and Studs with Regular Height Nuts (Class 10 or Strong Nuts)	
M5 X 0.8	57 ± 5 in-lb	640 ± 60 N-cm	78 ± 7 in-lb	885 ± 80 N-cm
M6 X 1.0	96 ± 9 in-lb	1018 ± 100 N-cm	133 ± 13 in-lb	1500 ± 150 N-cm
M8 X 1.25	19 ± 2 ft-lb	26 ± 3 N-m	27 ± 2 ft-lb	36 ± 3 N-m
M10 X 1.5	38 ± 4 ft-lb	52 ± 5 N-m	53 ± 5 ft-lb	72 ± 7 N-m
M12 X 1.75	66 ± 7 ft-lb	90 ± 10 N-m	92 ± 9 ft-lb	125 ± 12 N-m
M16 X 2.0	166 ± 15 ft-lb	225 ± 20 N-m	229 ± 22 ft-lb	310 ± 30 N-m
M20 X 2.5	325 ± 33 ft-lb	440 ± 45 N-m	450 ± 37 ft-lb	610 ± 50 N-m

**Note:** Reduce torque values listed in the table above by 25% for lubricated fasteners. Lubricated fasteners are defined as threads coated with a lubricant such as oil, graphite, or thread sealant such as Loctite.

**Note:** The nominal torque values listed above are based on 75% of the minimum proof load specified in SAE J1199. The tolerance is approximately ± 10% of the nominal torque value. Thin height nuts include jam nuts.

**Note:** Torque values may have to be reduced when installing fasteners into threaded aluminum or brass. The specific torque value should be determined based on the fastener size, the aluminum or base material strength, length of thread engagement, etc.

# SPECIFICATIONS

## Other Torque Specifications

### SAE Grade 8 Steel Set Screws

Thread Size	Recommended Torque	
	Square Head	Hex Socket
1/4 - 20 UNC	140 ± 20 in-lb	73 ± 12 in-lb
5/16 - 18 UNC	215 ± 35 in-lb	145 ± 20 in-lb
3/8 - 16 UNC	35 ± 10 ft-lb	18 ± 3 ft-lb
1/2 - 13 UNC	75 ± 15 ft-lb	50 ± 10 ft-lb

### Wheel Bolts and Lug Nuts

Thread Size	Recommended Torque**	
7/16 - 20 UNF Grade 5	65 ± 10 ft-lb	88 ± 14 N-m
1/2 - 20 UNF Grade 5	80 ± 10 ft-lb	108 ± 14 N-m
M12 X 1.25 Class 8.8	80 ± 10 ft-lb	108 ± 14 N-m
M12 X 1.5 Class 8.8	80 ± 10 ft-lb	108 ± 14 N-m

\*\* For steel wheels and non-lubricated fasteners.

### Thread Cutting Screws (Zinc Plated Steel)

Type 1, Type 23, or Type F	
Thread Size	Baseline Torque*
No. 6 - 32 UNC	20 ± 5 in-lb
No. 8 - 32 UNC	30 ± 5 in-lb
No.10 - 24 UNC	38 ± 7 in-lb
1/4 - 20 UNC	85 ± 15 in-lb
5/16 - 18 UNC	110 ± 20 in-lb
3/8 - 16 UNC	200 ± 100 in-lb

### Thread Cutting Screws (Zinc Plated Steel)

Thread Size	Threads per Inch		Baseline Torque*
	Type A	Type B	
No. 6	18	20	20 ± 5 in-lb
No. 8	15	18	30 ± 5 in-lb
No. 10	12	16	38 ± 7 in-lb
No. 12	11	14	85 ± 15 in-lb

\* Hole size, material strength, material thickness and finish must be considered when determining specific torque values. All torque values are based on non-lubricated fasteners.

### Conversion Factors

*in-lb X 11.2985 = N-cm*  
*ft-lb X 1.3558 = N-m*

*N-cm X 0.08851 = in-lb*  
*N-m X 0.73776 = ft-lb*

# SPECIFICATIONS

## Equivalents and Conversions

### Decimal and Millimeter Equivalents

Fractions	Decimals	mm	Fractions	Decimals	mm			
	1/64	0.015625	— 0.397	33/64	0.515625	— 13.097		
1/32	—	0.03125	— 0.794	17/32	—	0.53125	— 13.494	
	3/64	0.046875	— 1.191	35/64	0.546875	— 13.891		
1/16	—	0.0625	— 1.588	9/16	—	0.5625	— 14.288	
	5/64	0.078125	— 1.984	37/64	0.578125	— 14.684		
	3/32	—	0.9375	— 2.381	19/32	—	0.59375	— 15.081
	7/64	0.109275	— 2.778	39/64	0.609375	— 15.478		
1/8	—	0.1250	— 3.175	5/8	—	0.6250	— 15.875	
	9/64	0.140625	— 3.572	41/64	0.640625	— 16.272		
	5/32	—	0.15625	— 3.969	21/32	—	0.65625	— 16.669
	11/64	0.171875	— 4.366	43/64	0.671875	— 17.066		
3/16	—	0.1875	— 4.762	11/16	—	0.6875	— 17.462	
	13/64	0.203125	— 5.159	45/64	0.703125	— 17.859		
	7/32	—	0.21875	— 5.556	23/32	—	0.71875	— 18.256
	15/64	0.234375	— 5.953	47/64	0.734375	— 18.653		
1/4	—	0.2500	— 6.350	3/4	—	0.7500	— 19.050	
	17/64	0.265625	— 6.747	49/64	0.765625	— 19.447		
	9/32	—	0.28125	— 7.144	25/32	—	0.78125	— 19.844
	19/64	0.296875	— 7.541	51/64	0.796875	— 20.241		
5/16	—	0.3125	— 7.938	13/16	—	0.8125	— 20.638	
	21/64	0.328125	— 8.334	53/64	0.828125	— 21.034		
	11/32	—	0.34375	— 8.731	27/32	—	0.84375	— 21.431
	23/64	0.359375	— 9.128	55/64	0.859375	— 21.828		
3/8	—	0.3750	— 9.525	7/8	—	0.8750	— 22.225	
	25/64	0.390625	— 9.922	57/64	0.890625	— 22.622		
	13/32	—	0.40625	— 10.319	29/32	—	0.90625	— 23.019
	27/64	0.421875	— 10.716	59/64	0.921875	— 23.416		
7/16	—	0.4375	— 11.112	15/16	—	0.9375	— 23.812	
	29/64	0.453125	— 11.509	61/64	0.953125	— 24.209		
	15/32	—	0.46875	— 11.906	31/32	—	0.96875	— 24.606
	31/64	0.484375	— 12.303	63/64	0.984375	— 25.003		
1/2	—	0.5000	— 12.700	1	—	1.000	— 25.400	
	1 mm = 0.03937 in.			0.001 in. = 0.0254 mm				

### U.S to Metric Conversions

	To Convert	Into	Multiply By
<b>Linear Measurement</b>	Miles	Kilometers	1.609
	Yards	Meters	0.9144
	Feet	Meters	0.3048
	Feet	Centimeters	30.48
	Inches	Meters	0.0254
	Inches	Centimeters	2.54
	Inches	Millimeters	25.4
<b>Area</b>	Square Miles	Square Kilometers	2.59
	Square Feet	Square Meters	0.0929
	Square Inches	Square Centimeters	6.452
	Acre	Hectare	0.4047
<b>Volume</b>	Cubic Yards	Cubic Meters	0.7646
	Cubic Feet	Cubic Meters	0.02832
	Cubic Inches	Cubic Centimeters	16.39
<b>Weight</b>	Tons (Short)	Metric Tons	0.9078
	Pounds	Kilograms	0.4536
	Ounces (Avdp.)	Grams	28.3495
<b>Pressure</b>	Pounds/Sq. In.	Kilopascal	6.895
	Pounds/Sq. In.	Bar	0.069
<b>Work</b>	Foot-pounds	Newton-Meters	1.356
	Foot-pounds	Kilogram-Meters	0.1383
	Inch-pounds	Kilogram-Centimeters	1.152144
<b>Liquid Volume</b>	Quarts	Liters	0.9463
	Gallons	Liters	3.785
<b>Liquid Flow</b>	Gallons/Minute	Liters/Minute	3.785
<b>Temperature</b>	Fahrenheit	Celsius	1. Subtract 32°
			2. Multiply by 5/9

# SPECIFICATIONS

## Product Specifications

Name	LX420	LX425	LX460	LX465	LX500
<b>Engine</b>	18 HP Single Cylinder Kohler Courage	20 HP Single Cylinder Kohler Courage	20 HP Single Cylinder Kohler Courage	20 HP Single Cylinder Kohler Courage	22 HP Twin Cylinder Kohler Courage
<b>RPM Setting - High</b>	3450 ± 75	3450 ± 75	3450 ± 75	3450 ± 75	3300 ± 75
<b>RPM Setting - Low</b>	1700 ± 150	1700 ± 150	1700 ± 150	1700 ± 150	1750 ± 150
<b>Construction</b>	12 Gauge Steel Frame				
<b>Fuel Capacity</b>	3.0 Gallon (11.4 Liters)				
<b>Wheel Base</b>	46" (116.8cm)	46" (116.8cm)	46" (116.8cm)	46" (116.8cm)	46" (116.8cm)
<b>Overall Length</b>	68" (172.7cm)	68" (172.7cm)	68" (172.7cm)	68" (172.7cm)	68" (172.7cm)
<b>Overall Width</b>	42" (114.3cm)	42" (114.3cm)	48" (127.9cm)	49" (124.4cm)	54" (137.2cm)
<b>Overall Height</b>	43" (109.2cm)	43" (109.2cm)	43" (109.2cm)	43" (109.2cm)	43" (109.2cm)
<b>Weight (approximate)</b>	498 lbs. (225.9kg)	498 lbs. (225.9kg)	501 lbs. (227.25kg)	498 lbs. (225.9kg)	525 lbs. (238kg)
<b>Traction System</b>	CVT* Transaxle	CVT* Transaxle	CVT* Transaxle	Hydro-Gear LT-0510	CVT* Transaxle
<b>Ground Speed - Forward</b>	0 - 5.5 mph	0 - 5.5 mph	0 - 5.5 mph	0 - 6.4 mph	0 - 5.5 mph
<b>Ground Speed - Reverse</b>	0 - 2.3 mph	0 - 2.3 mph	0 - 2.3 mph	0 - 2.5 mph	0 - 2.3 mph
<b>Front Tires</b>	15 x 6				
<b>Rear Tires</b>	20 x 8	20 x 8	20 x 8	20 x 8	20 x 10
<b>Tire Pressure (Front/Rear)</b>	14psi / 10psi				
<b>Turning Radius</b>	18" (46cm)				
<b>Electrical System</b>	Voltage: 12-volt Negative Ground Battery: 190 CCA Alternator: 15 Amp Regulated Fuse: 20 Amp				
<b>Mower Deck</b>	42", Two Blade, 13 Gauge Steel	42", Two Blade, 13 Gauge Steel	46", Three Blade, 12 Gauge Steel	46", Three Blade, 12 Gauge Steel	50", Three Blade, 12 Gauge Steel

CVT = Constant Velocity Transaxle

## Front Pivot Axle Replacement

### Removal

1. Disconnect the negative and then the positive battery cable.
2. Remove the mower deck: 42" deck on page 7-64; 46" deck on page 7-69; 50" deck on page 7-74.
3. Remove the deck rod from the deck hanger bracket (Fig. 001).



Fig 001

PICT-7399a

4. Raise the hood (Fig. 002).



Fig 002

PICT-7063

5. Unplug the headlights from the wire harness (Fig. 003).



Fig 003

PICT-7064

6. Remove the hood from the frame (Fig. 004).



Fig 004

PICT-7066

# CHASSIS

7. Elevate and secure the front end of the machine so the front axle can be accessed.
8. Remove the hub caps from the two front tires (Fig. 005).



Fig 005 PICT-7400

9. Remove and discard the cotter pins from the two axles (Fig. 006).



Fig 006 PICT-7401

10. Remove the washer from the two axles (Fig. 007).



Fig 007 PICT-7402

11. Remove the wheel and tire assembly from the two axle assemblies (Fig. 008).



Fig 008 PICT-7403



**Note:** There are inner and outer bushings included with the rim assembly. When the wheel is removed, the inner bushing may come off with the wheel or stay on the axle.

**Bushing stays in rim of tire (Fig. 009):**



Fig 009

PICT-7410a

**Bushing stays on axle (Fig. 010):**



Fig 010

PICT-7413

12. Remove the bushing from each of the axle assemblies if it stayed in place at tire assembly removal (Fig. 011).



Fig 011

PICT-7415a

13. Remove the nut securing the ball joint to the axle assemblies (Fig. 012).



Fig 012

PICT-7421

# CHASSIS

14. Remove the ball joint from the axle assembly (Fig. 013).



Fig 013

PICT-7423

16. Remove the push nut from the axle assembly (Fig. 015).



Fig 015

PICT-7425

15. Remove the cap from the axle assembly (Fig. 014).



Fig 014

PICT-7424

17. Remove the axle assembly from the front pivot axle (Fig. 016).



Fig 016

PICT-7431a

18. Repeat steps 13-17 to remove the second axle.

19. Cut the cable tie securing the wire harness to the right hand hood pivot bracket (Fig. 017).

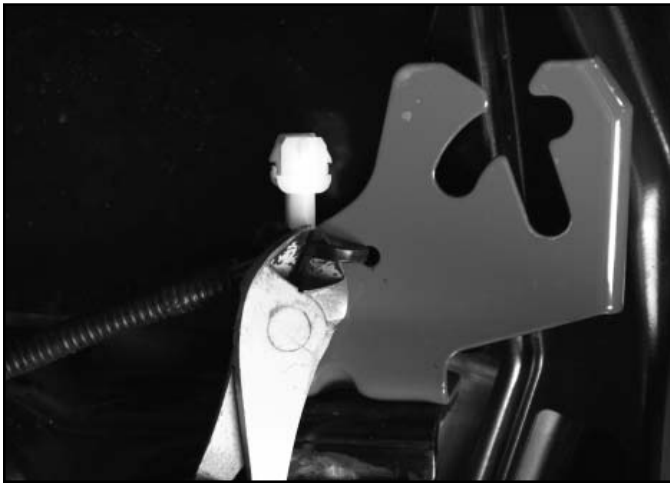

Fig 017

PICT-7434

20. Cut the electrical tape securing the wire harness to the plastic harness guide (Fig. 018).



Fig 018

PICT-7462a

21. Support the front pivot axle (Fig. 019).

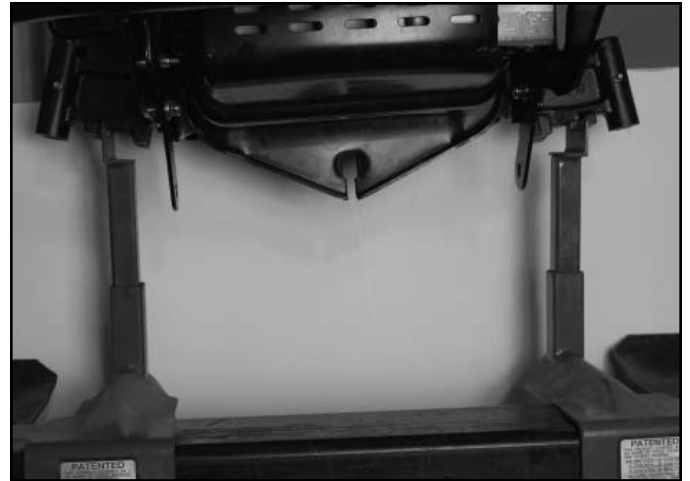

Fig 019

PICT-7439a

22. Remove the nuts from the 2 bolts securing the pivot axle and deck hanger bracket to the frame (Fig. 020).

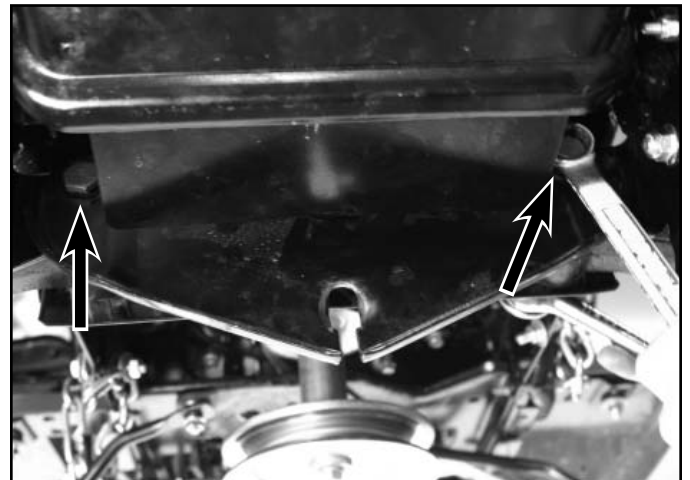

Fig 020

PICT-7442

# CHASSIS

23. Remove the 4 bolts (2 on the right, 2 on the left) securing the left and right pivot supports to the frame (Fig. 021).

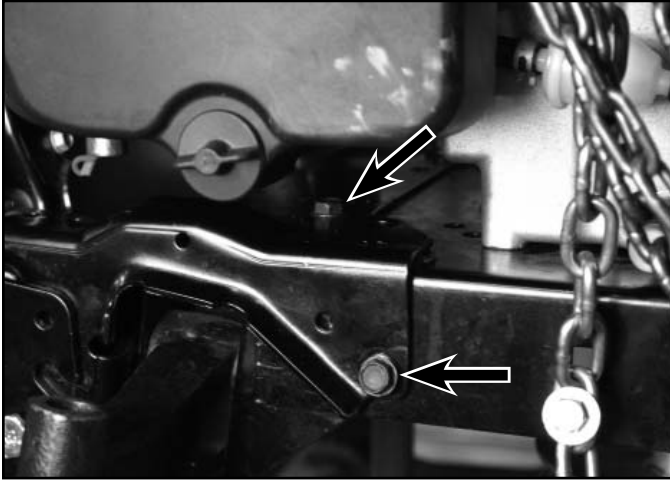

Fig 021

PICT-7436

25. Remove the second bolt and deck hanger plate from the pivot axle (Fig. 023).



Fig 023

PICT-7447

24. Remove one of the bolts securing the deck hanger plate and pivot axle to the frame (Fig. 022).

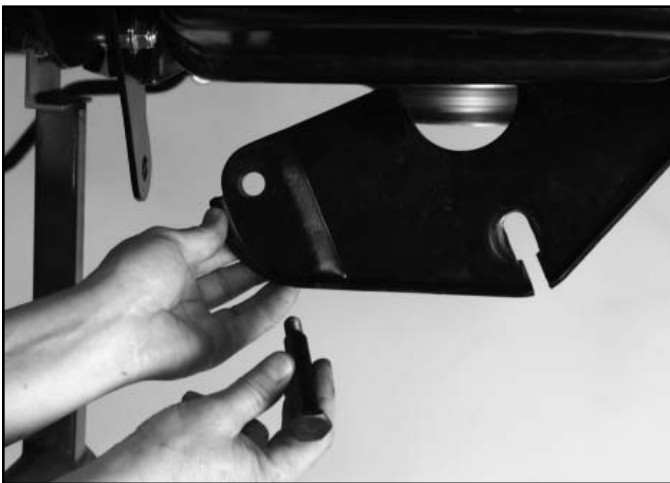

Fig 022

PICT-7444

26. Remove the muffler, heat shield and bracket assembly (Fig. 024).

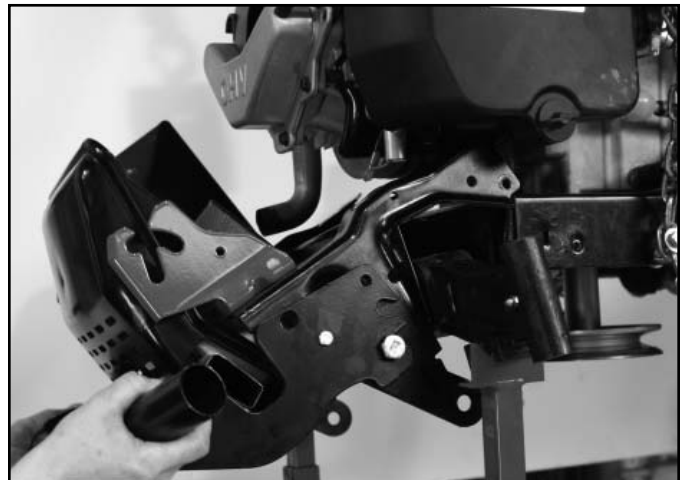

Fig 024

PICT-7449

27. Remove the pivot bar bracket (Fig. 025).



Fig 025

PICT-7450

28. Remove the front pivot axle (Fig. 026).



Fig 026

PICT-7451

## Installation

1. Position the front pivot axle to the front of the frame (Fig. 027).



Fig 027

PICT-7451

2. Position the pivot bar bracket to the front pivot axle (Fig. 028).



Fig 028

PICT-7450

# CHASSIS

3. Position the muffler, heat shield and bracket assembly to the frame (Fig. 029).



Fig 029

PICT-7449

4. Loosely install 4 bolts securing the left and right pivot supports to the frame (2 bolts on the left side bracket and 2 bolts on the right side bracket) (Fig. 031).

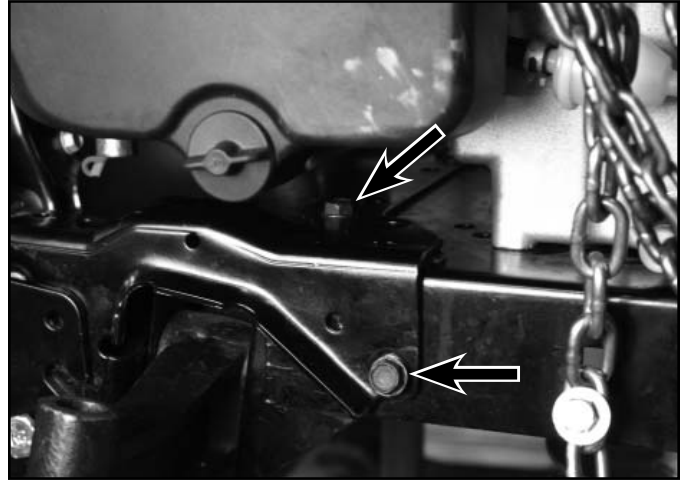

Fig 031

PICT-7436

3

**Note:** The tailpipe needs to be aligned and inserted into the muffler upon assembly (Fig. 030).

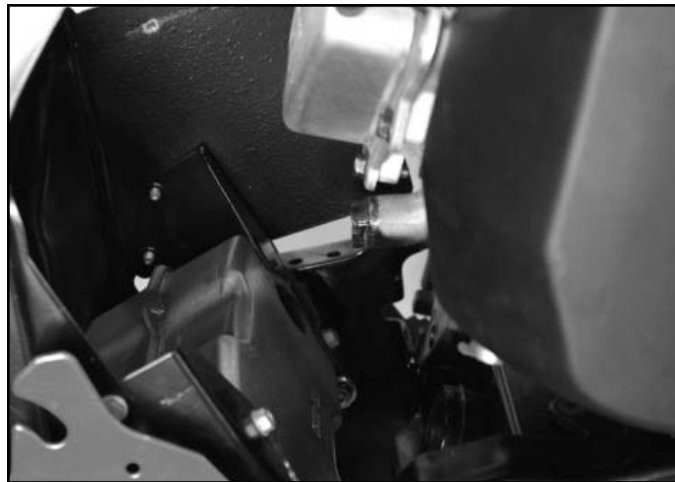

Fig 030

PICT-7457

5. Position the deck hanger plate to the pivot axle and install a shoulder bolt (Fig. 032).



Fig 032

PICT-7447

6. Align the second hole in the deck hanger bracket with the pivot axle and install a second shoulder bolt (Fig. 033).



Fig 033

PICT-7444

8. Tighten the 4 bolts securing the left and right pivot supports to the frame (2 bolts on the left side bracket and 2 bolts on the right side bracket) (Fig. 035).

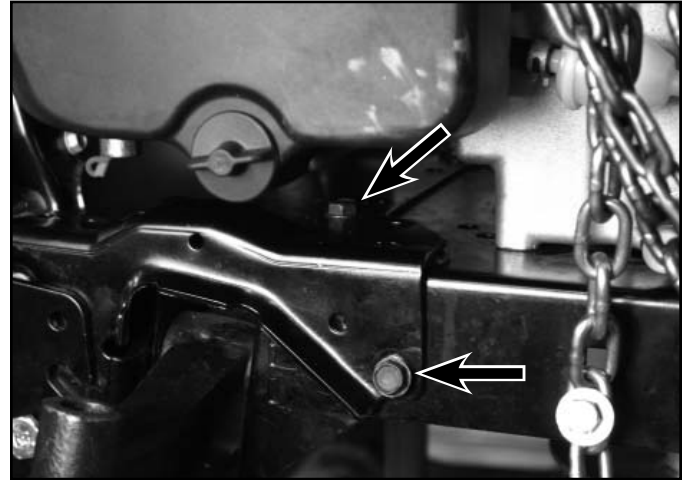

Fig 035

PICT-7436

7. Loosely install a nut onto the 2 shoulder bolts securing the pivot axle and deck hanger bracket to the frame (Fig. 034).

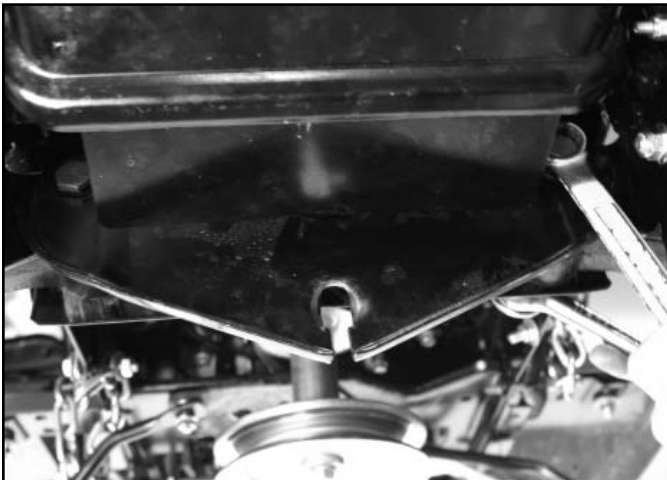

Fig 034

PICT-7442

9. Torque the 2 nuts installed on the shoulder bolts securing the pivot axle and deck hanger bracket to the frame to  $30 \pm 3$  ft-lbs. ( $40.67 \pm 4.06$  Nm) (Fig. 036).

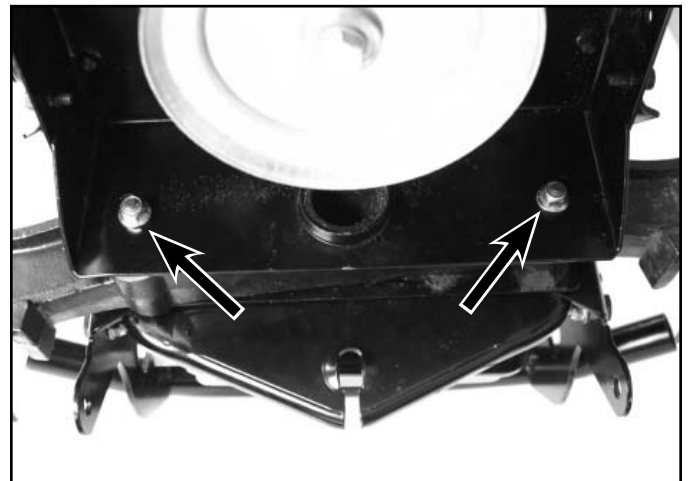

Fig 036

PICT-7460

# CHASSIS

10. Apply electrical tape to secure the wire harness to the plastic harness guide (Fig. 037).



Fig 037

PICT-7464

11. Secure the wire harness to the right hand hood pivot bracket with a cable tie (Fig. 038).

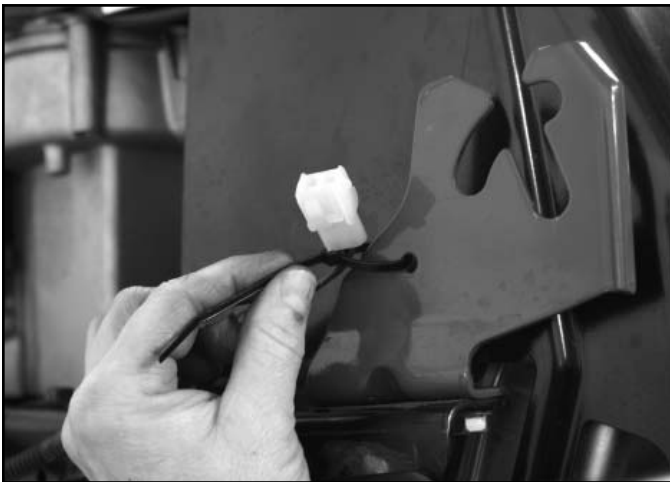

Fig 038

PICT-7466

**Note:** The following steps, 12 thru 21, should be done on both the right and left sides of the axle.

12. Insert the axle assembly into the pivot axle (Fig. 039).



Fig 039

PICT-7468a

13. Position the ball joint into the axle assembly (Fig. 040).



Fig 040

PICT-7469a



14. Install a nut onto the ball joint and torque to 12.5 to 29 ft-lbs. (16.94 to 39.54 Nm) (Fig. 041).



Fig 041

PICT-7470a

15. Install a cap/push nut onto the axle assembly (Fig. 042).



Fig 042

PICT-7471

16. Apply grease to the axle assembly (Fig. 043).



Fig 043

PICT-7472

17. Slide the wheel and tire assembly onto the axle assembly (Fig. 044).

**Note:** The wheel bearing is installed in the rim.



Fig 044

PICT-7473

# CHASSIS

18. Install a washer onto the axle assembly (Fig. 045).



Fig 045

PICT-7474a

20. Apply grease to the wheel bearing (Fig. 047).



Fig 047

PICT-7477a

19. Install a cotter pin into the axle assembly (Fig. 046).



Fig 046

PICT-7475a

21. Install the hub cap (Fig. 048).



Fig 048

PICT-7478

3

22. Lower the machine.

23. Position the hood on the chassis (Fig. 049).



Fig 049

PICT-7066

24. Plug the headlights into the wire harness (Fig. 050).



Fig 050

PICT-7064

25. Lower the hood (Fig. 051).



Fig 051

PICT-7063

26. Install the deck rod into the deck hanger bracket (Fig. 052).



Fig 052

PICT-7399a

27. Install the mower deck: 42" deck on page 7-67; 46" deck on page 7-72; 50" deck on page 7-76.

28. Connect the positive and then the negative battery cable.

29. Check the toe-in measurement and adjust as needed. Refer to "Front Wheel Toe-In Measurement" on page 3-85.

# CHASSIS

## Axle Assembly Replacement

### Removal

1. Raise the front of the machine.
2. Remove the hub cap (Fig. 053).



Fig 053

PICT-7067

3. Remove the cotter pin from the axle assembly (Fig. 054).



Fig 054

PICT-7069

4. Remove the washer from the axle assembly (Fig. 055).



Fig 055

PICT-7070

5. Remove the wheel and tire assembly from the axle assembly (Fig. 056).



Fig 056

PICT-7072

**Note:** There are inner and outer bushings included with the rim assembly. When the wheel is removed, the inner bushing may come off with the wheel or stay on the axle assembly.

**Bushing stays in rim of tire (Fig. 057):**



Fig 057

PICT-7410a

**Bushing stays on axle assembly (Fig. 058):**



Fig 058

PICT-7413

6. Remove the bushing from each of the axle assemblies if it stayed in place at tire assembly removal (Fig. 059).



Fig 059

PICT-7415a

7. Remove the nut securing the ball joint to the axle assembly (Fig. 060).



Fig 060

PICT-7077a

# CHASSIS

8. Remove the ball joint from the axle assembly (Fig. 061).



Fig 061

PICT-7078

10. Remove the push nut from the axle assembly (Fig. 063).



Fig 063

PICT-7425

9. Remove the cap from the axle assembly (Fig. 062).



Fig 062

PICT-7424

11. Remove the axle assembly from the axle pivot (Fig. 064).



Fig 064

PICT-7087

## Installation

1. Position the axle assembly into the axle pivot (Fig. 065).



Fig 065

PICT-7087

2. Install a cap/push nut onto the axle assembly (Fig. 066).



Fig 066

PICT-7471

3. Position the ball joint into the axle assembly (Fig. 067).



Fig 067

PICT-7078

4. Install a nut onto the ball joint and torque to 12.5 to 29 ft-lbs. (16.94 to 39.54 Nm) (Fig. 068).



Fig 068

PICT-7077a

# CHASSIS

5. Apply grease to lubricate the front axle pivot (Fig. 069).

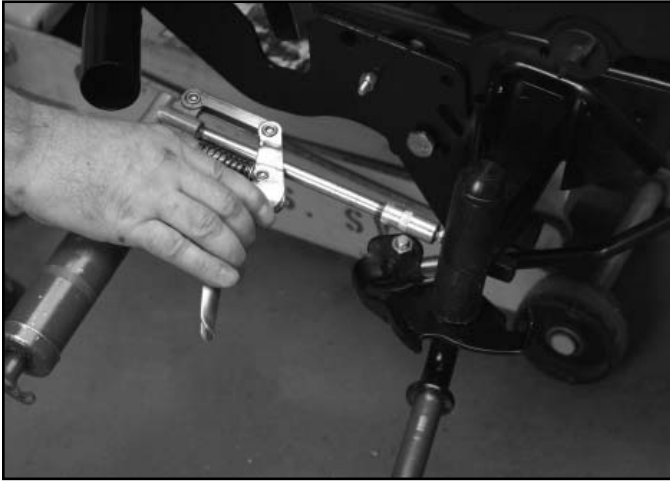

Fig 069

PICT-7091a

7. Install a washer onto the axle assembly (Fig. 071).



Fig 071

PICT-7070

6. Slide the wheel and tire assembly onto the axle assembly (Fig. 070).

**Note:** The wheel bearing is installed in the rim.



Fig 070

PICT-7072

8. Install a cotter pin into the axle pivot (Fig. 072).



Fig 072

PICT-7093



9. Apply grease to the wheel bearing (Fig. 073).



Fig 073

PICT-7092

10. Install the hub cap (Fig. 074).



Fig 074

PICT-7067

11. Lower the machine.

## Steering Wheel Replacement

### Removal

1. Remove the steering wheel cap (Fig. 075).



Fig 075

PICT-7103

2. Remove the bolt and washer securing the steering wheel to the steering shaft (Fig. 076).



Fig 076

PICT-7104

# CHASSIS

3. Remove the steering wheel (Fig. 077).



Fig 077

PICT-7105

2. Install the washer and bolt to secure the steering wheel to the steering shaft (Fig. 079).



Fig 079

PICT-7104

## Installation

1. Position the front tires so that they are pointing straight forward. Slide the steering wheel onto the steering shaft (Fig. 078).



Fig 078

PICT-7105

3. Install the steering wheel cap (Fig. 080).



Fig 080

PICT-7106

## Steering Shaft Replacement

### Removal

1. Remove the steering wheel cap (Fig. 081).



Fig 081

PICT-7103

2. Remove the bolt and washer securing the steering wheel to the steering shaft (Fig. 082).



Fig 082

PICT-7104

3. Remove the steering wheel (Fig. 083).



Fig 083

PICT-7105

4. Raise the hood (Fig. 084).



Fig 084

PICT-7063a

# CHASSIS

5. Remove the mower deck: 42" deck on page 7-64; 46" deck on page 7-69; 50" deck on page 7-74.
6. Disconnect the fuel line from the fuel filter and drain all the fuel from the fuel tank. Reconnect the fuel line to the fuel filter (Fig. 085).

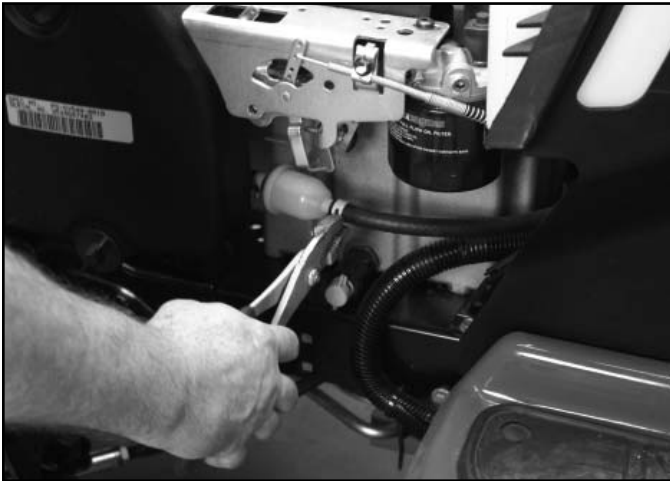

Fig 085

PICT-7094

8. Lift the fuel tank out of the tower (Fig. 087).



Fig 087

PICT-7655a

7. Remove the two screws securing the fuel tank support rods to the dash supports (Fig. 086).



Fig 086

PICT-7099a

9. Raise the machine to access the steering gear assembly.
10. Secure the steering gear in place with a Phillips screwdriver and remove the nut from the end of the steering shaft (Fig. 088).



Fig 088

PICT-7656a

11. Remove the pinion from the steering shaft (Fig. 089).



Fig 089

PICT-7659a

12. Push up on the steering shaft and remove the washer (Fig. 090).

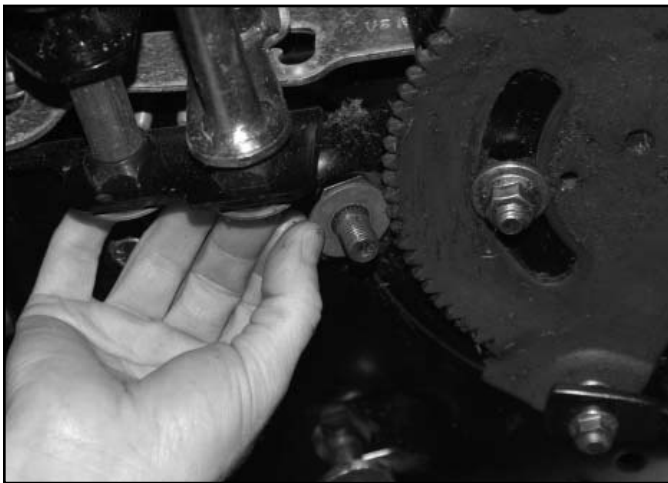

Fig 090

PICT-7661a

13. Lower the machine.

14. Pull the steering shaft up out of the hex flange bearing, angle the steering shaft in between the pedal levers and lower it out of the tower (Fig. 091).



Fig 091

PICT-7663

15. Remove the hex flange bushing (Fig. 092).

**Note:** Inspect the hex flange bushing and replace if worn or damaged.



Fig 092

PICT-7666a

# CHASSIS

## Installation

1. Install the hex flange bushing into the steering support bracket ensuring the hex is seated in the bracket (Fig. 093).

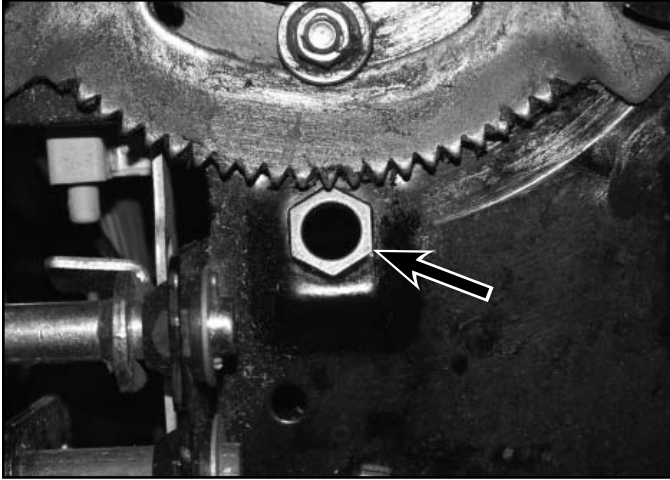

Fig 093

PICT-7668a

2. Slide the steering shaft up into the tower from below, insert the lower end of the steering shaft into the hex flange bushing (Fig. 094).



Fig 094

PICT-7663

3. Raise the tractor.
4. Push up on the steering shaft to install a washer onto the steering shaft (Fig. 095).



Fig 095

PICT-7661a

5. Slide the pinion onto the steering shaft (Fig. 096).



Fig 096

PICT-7659a

- Loosely install a nut on the steering shaft. Secure the steering gear in place with a Phillips screwdriver and tighten the nut (Fig. 097).

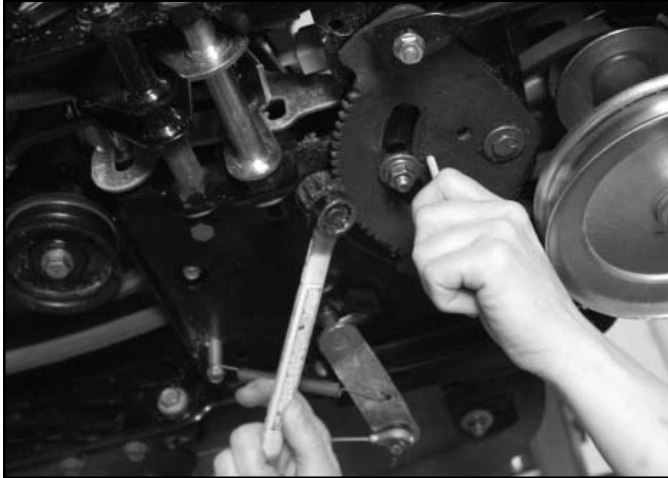

Fig 097

PICT-7656a

- Lower the tractor.
- Position the fuel tank into the tower (Fig. 099).



Fig 099

PICT-7655a

- Grease the pinion gear with #2 general purpose grease (Fig. 098).

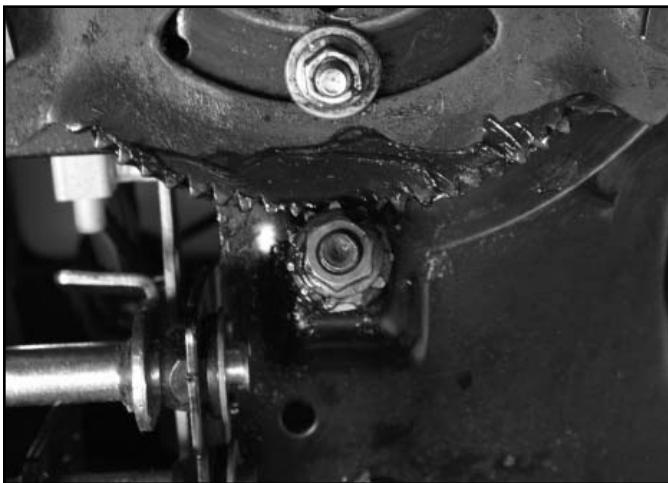

Fig 098

PICT-7676

- Position the fuel tank support rods and install two screws securing the fuel tank support rods to the dash supports (Fig. 100).



Fig 100

PICT-7099a

# CHASSIS

11. Lower the hood (Fig. 101).



Fig 101

PICT-7063a

13. Install the washer and bolt to secure the steering wheel to the steering shaft (Fig. 103).



Fig 103

PICT-7104

12. With the tractor's wheels straight ahead, position the steering wheel onto the steering shaft (Fig. 102).



Fig 102

PICT-7105

14. Install the steering wheel cap (Fig. 104).



Fig 104

PICT-7106

15. Install the mower deck: 42" deck on page 7-67; 46" deck on page 7-72; 50" deck on page 7-76.



## Electric PTO Clutch Replacement

### Removal

1. Remove the mower deck from the tractor. Refer to "50" Mower Deck Removal" on page 7-74.
2. Raise the tractor so the clutch can be accessed.
3. Unplug the clutch from the wire harness (Fig. 105).
4. Route the clutch connector out through the slot in the frame.
5. Remove the bolt and lock washer securing the clutch to the crankshaft (Fig. 106).



Fig 105

PICT-7977a

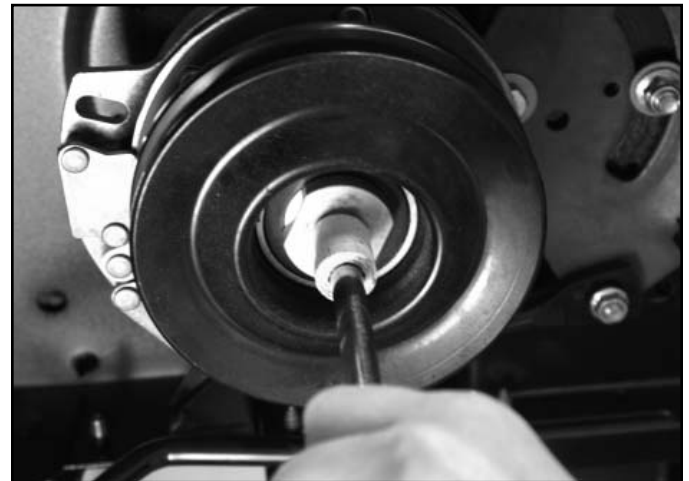

Fig 106

PICT-7982

6. Remove the clutch and washer(s) from the crankshaft (Fig. 107).



Fig 107

PICT-7988

# CHASSIS

## Installation

1. Apply anti-seize compound to the crankshaft (Fig. 108).



Fig 108

PICT-7984

2. Lay the washer(s) on top of the clutch (Fig. 109).



Fig 109

PICT-7985

3. Align the keyway in the clutch with the key on the crankshaft and slide the clutch and washer assembly onto the crankshaft. (Fig. 110).



Fig 110

PICT-7988

4. Install the bolt and lock washer securing the clutch to the crankshaft. Torque the bolt to 37.5–50 ft-lbs. (50.84–67.79 Nm) (Fig. 111).



Fig 111

PICT-7986

5. Route the clutch plug through the slot in the frame.
6. Plug the clutch into the wire harness (Fig. 112).



Fig 112

PICT-7977a

7. Lower the tractor to the ground.
8. Install the mower deck onto the tractor. Refer to "50" Mower Deck Installation" on page 7-76.

## Fuel Tank Replacement

### Removal

1. Raise the hood (Fig. 113).



Fig 113

PICT-7063

2. Disconnect the fuel line from the fuel filter and drain all the fuel from the fuel tank into an approved container (Fig. 114).



Fig 114

PICT-7094

# CHASSIS

3. Remove the two screws securing the fuel tank support rods to the dash supports (Fig. 115).



Fig 115

PICT-7099a

## Installation

1. Position the fuel tank into the engine compartment (Fig. 117).



Fig 117

PICT-7100a

4. Remove the fuel tank from the engine compartment (Fig. 116).



Fig 116

PICT-7100a

2. Position the fuel tank support rods and install screws to secure the fuel tank (Fig. 118).



Fig 118

PICT-7099a

3. Connect the fuel line to the fuel filter and secure with a hose clamp (Fig. 119).

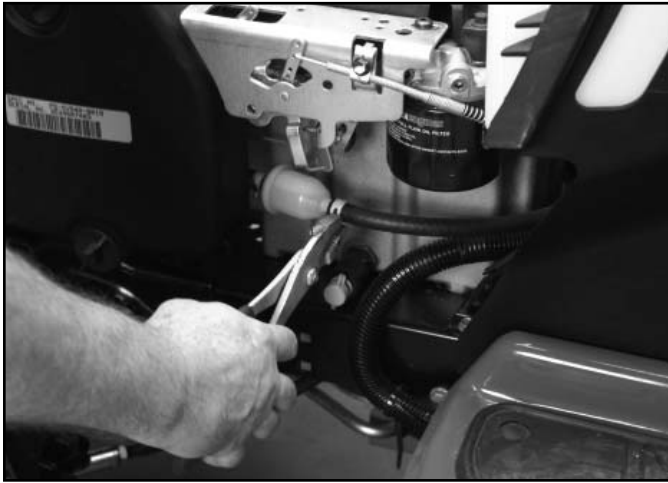

Fig 119

PICT-7094

4. Lower the hood (Fig. 120).



Fig 120

PICT-7063

## Hood Replacement

### Removal

1. Raise the hood (Fig. 121).



Fig 121

PICT-7063

2. Unplug the headlights from the wire harness (Fig. 122).



Fig 122

PICT-7064

# CHASSIS

3. Remove the hood from the chassis (Fig. 123).



Fig 123

PICT-7066

2. Plug the headlights to the wire harness (Fig. 125).



Fig 125

PICT-7064

## Installation

1. Position the hood on the chassis (Fig. 124).



Fig 124

PICT-7066

3. Lower the hood (Fig. 126).



Fig 126

PICT-7063

## Fender Replacement

### Removal

1. Lift the seat to access the battery compartment.
2. Disconnect the negative battery cable from the battery terminal (Fig. 127).



Fig 127

PICT-7107

3. Disconnect the positive battery cable from the battery terminal (Fig. 128).



Fig 128

PICT-7108

4. Remove the battery hold down rod (Fig. 129).



Fig 129

PICT-7109a

5. Remove the battery from the battery tray (Fig. 130).



Fig 130

PICT-7110

# CHASSIS

6. Remove the battery tray (Fig. 131).

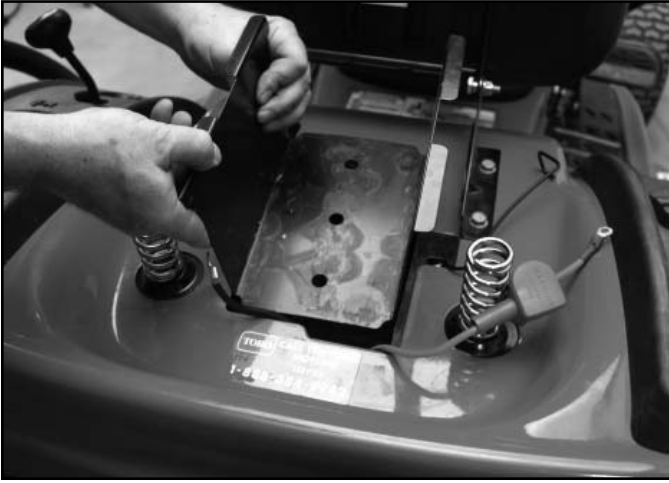

Fig 131

PICT-7111

8. Loosen the bolt and nut securing the left seat mount bracket to the seat bracket (Fig. 133).



Fig 133

PICT-7115

7. Disconnect the two seat switch wires (Fig. 132).



Fig 132

PICT-7113

9. Release the extension spring from the seat mount bracket (Fig. 134).



Fig 134

PICT-7117

3



10. Remove the 4 bolts securing the seat mount brackets to the fender (Fig. 135).

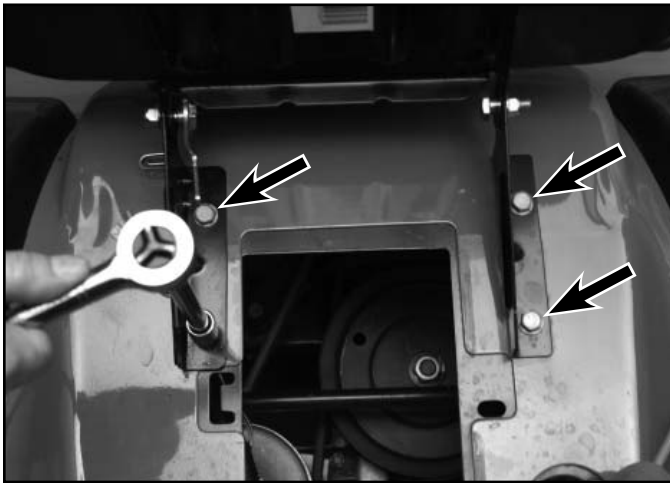

Fig 135

PICT-7119

12. Remove the shifter knob from the shift lever (Fig. 137).



Fig 137

PICT-7122

11. Remove the seat (Fig. 136).



Fig 136

PICT-7121

13. Remove the height-of-cut grip from the height-of-cut lever (Fig. 138).



Fig 138

PICT-7123

# CHASSIS

14. Pry up the front portion of the left hand foot pad (Fig. 139).



Fig 139

PICT-7124

16. Pry up the front portion of the right hand foot pad (Fig. 141).



Fig 141

PICT-7213

3

15. Remove the bolt, nut and washer securing the fender to the frame (Fig. 140).



Fig 140

PICT-7125

17. Remove the bolt nut and washer securing the fender to the frame (Fig. 142).



Fig 142

PICT-7127a

18. Locate the 2 screws under the danger decal on the fender. Cut the decal to expose the bolt heads (Fig. 143).

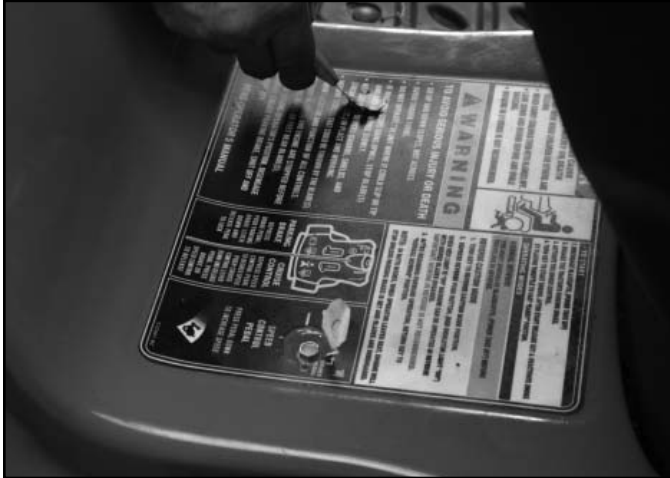

Fig 143

PICT-7129

20. Raise the fender and prop it slightly to access the fasteners securing the brake pedal to the brake control assembly (Fig. 145).



Fig 145

PICT-7131a

19. Remove the 2 screws (Fig. 144).



Fig 144

PICT-7130

- Remove the two sets of fasteners securing the brake pedal lever to the brake control assembly (Fig. 146):

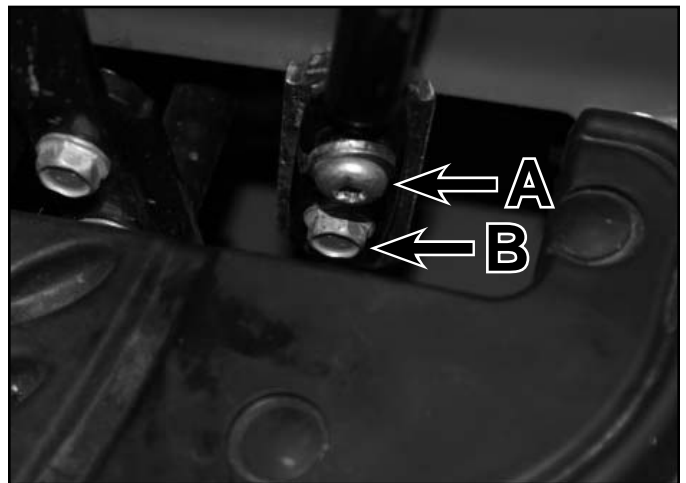

Fig 146

PICT-7132

- A. Torx screw and washer
- B. Hex head bolt, lock washer and nut

# CHASSIS

21. Remove the brake pedal (Fig. 147).



Fig 147

PICT-7134

23. Remove the speed control pedal (Fig. 149).



Fig 149

PICT-7136

22. Remove the two bolts securing the speed control pedal to the speed control assembly (Fig. 148).



Fig 148

PICT-7135

24. Remove the fender (Fig. 150).



Fig 150

PICT-7138

## Installation

1. Position the fender onto the frame (Fig. 151).



Fig 151

PICT-7138

2. Position the speed control pedal to the speed control assembly (Fig. 152).



Fig 152

PICT-7136

3. Install 2 bolts to secure the speed control pedal to the speed control assembly (Fig. 153).



Fig 153

PICT-7211

4. Position the brake pedal to the brake control assembly (Fig. 154).



Fig 154

PICT-7212

# CHASSIS

5. Raise the fender and prop it slightly to access the fasteners securing the brake pedal to the brake control assembly (Fig. 155).



Fig 155

PICT-7131a

7. Begin securing the fender to the frame by installing 2 screws located under the danger decal (Fig. 157). Glue the cut decal pieces into place or replace the decal.



Fig 157

PICT-7130

3

6. Install the two sets of fasteners securing the brake pedal lever to the brake control assembly (Fig. 156):

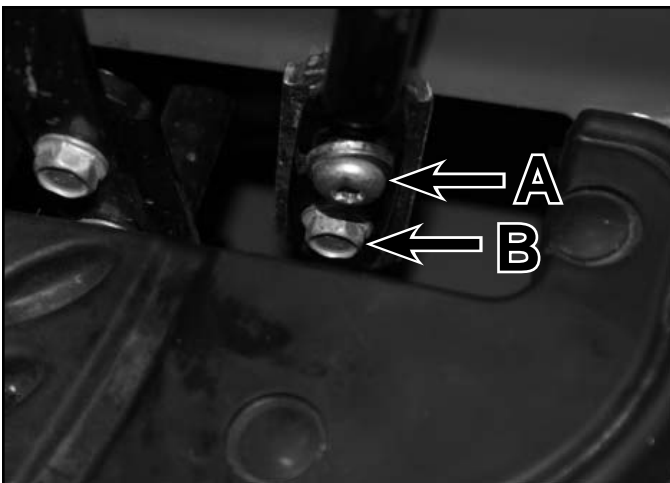

Fig 156

PICT-7132

8. Install the bolt, nut and washer securing the right side of the fender to the frame and tighten (Fig. 158).



Fig 158

PICT-7127a

- A. Torx screw and washer
- B. Hex head bolt, washer and nut

9. Push the foot pad down to the foot rest by applying pressure down on the ratchet clip (Fig. 159).



Fig 159

PICT-7216

11. Push the left side foot pad down to the foot rest by applying pressure down on the ratchet clip (Fig. 161).



Fig 161

PICT-7217

10. Install the bolt, nut and washer securing the left side of the fender to the frame and tighten (Fig. 160).



Fig 160

PICT-7125

12. Install the height-of-cut grip onto the height-of-cut lever (Fig. 162).



Fig 162

PICT-7123

# CHASSIS

13. Install the shifter knob onto the shift lever (Fig. 163).



Fig 163

PICT-7122

15. Install the 4 bolts securing the seat mount brackets to the fender (Fig. 165).



Fig 165

PICT-7119

14. Position the seat onto the fender, aligning the seat mount bracket holes with the holes in the fender (Fig. 164).



Fig 164

PICT-7121

16. Loosen the bolt and nut securing the left seat mount bracket to the seat (Fig. 166).



Fig 166

PICT-7115



17. Install the extension spring from the seat mount bracket to the seat pivot bracket (Fig. 167).



Fig 167

PICT-7117

19. Connect the two seat switch connectors to the switch springs (Fig. 169).

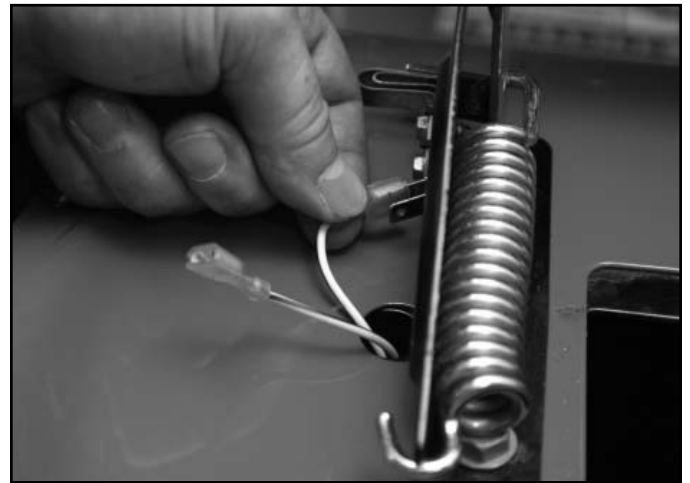

Fig 169

PICT-7113

18. Tighten the bolt and nut to secure the left seat mount bracket to the seat mount (Fig. 168).



Fig 168

PICT-7115

20. Install the battery tray (Fig. 170).



Fig 170

PICT-7111

# CHASSIS

21. Install the battery in the battery tray (Fig. 171).



Fig 171

PICT-7110

23. Connect the positive battery cable to the battery terminal (Fig. 173).



Fig 173

PICT-7108

22. Install the battery hold down rod (Fig. 172).



Fig 172

PICT-7109a

24. Connect the negative battery cable to the battery terminal (Fig. 174).



Fig 174

PICT-7107

25. Test operate tractor to ensure all controls and the seat switch are operating properly.

## Tower Replacement

### Removal

1. Remove the steering wheel cap (Fig. 175).



Fig 175

PICT-7141

2. Remove the bolt and washer securing the steering wheel to the steering shaft (Fig. 176).



Fig 176

PICT-7142

3. Remove the steering wheel (Fig. 177).



Fig 177

PICT-7143

4. Disconnect the fuel line from the fuel filter and drain all the fuel from the fuel tank into an approved container (Fig. 178).



Fig 178

PICT-7094

# CHASSIS

5. Remove the rear fender. See "Fender Replacement - Removal" on page 3-33.
6. Remove the two screws securing the fuel tank support rods to the tower supports (Fig. 179).



Fig 179

PICT-7144a

8. Unplug the hour meter from the wire harness (Fig. 181).

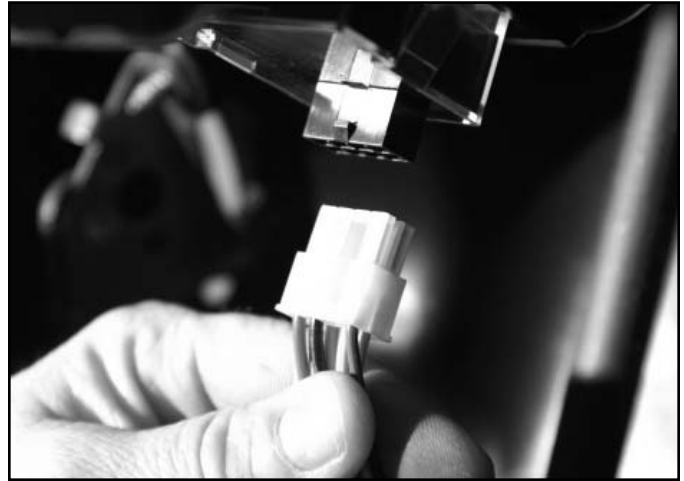

Fig 181

PICT-7148

7. Remove the fuel tank from the engine compartment (Fig. 180).



Fig 180

PICT-7146a

9. **Electric PTO models:** Unplug the electric PTO switch plug (Fig. 182).

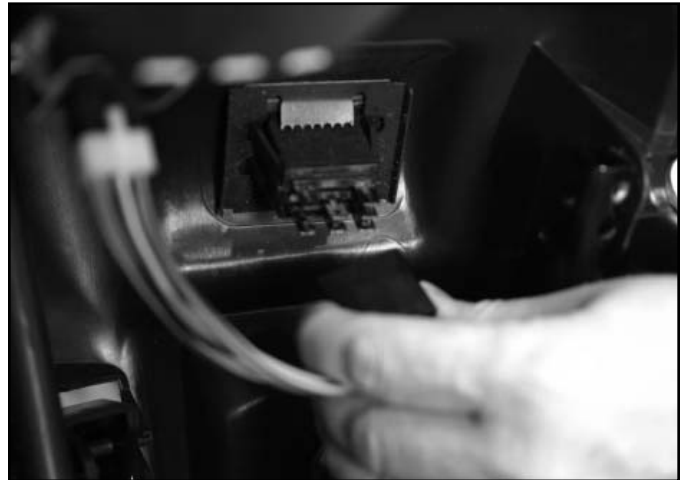

Fig 182

PICT-9826

10. Disconnect the ignition module from the wire harness (Fig. 183).



Fig 183

PICT-7149

12. Remove the fuse holder from the tower support by depressing the tabs (Fig. 185).



Fig 185

PICT-7210

11. Unplug the ignition switch from the wire harness (Fig. 184).

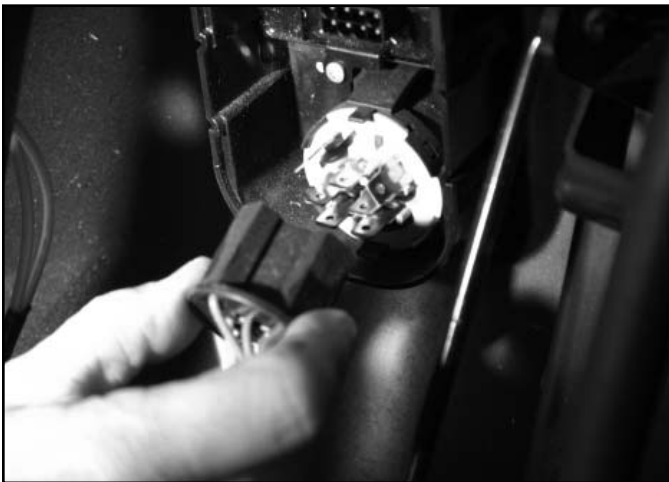

Fig 184

PICT-7150

13. Remove the throttle decal from the tower (Fig. 186).



Fig 186

PICT-7153

# CHASSIS

14. Remove the bolt and nut securing the control knob to the throttle/choke assembly (Fig. 187).



Fig 187

PICT-7154

16. Remove the 2 screws securing the throttle/choke assembly to the tower (Fig. 189).



Fig 189

PICT-7156

15. Remove the control knob (Fig. 188).



Fig 188

PICT-7155

17. Pull the throttle/choke assembly out from the rear of the tower (Fig. 190).



Fig 190

PICT-7158

18. Remove the 2 nuts securing the deck engage handle to the PTO engage lever and stop bracket (manual PTO models) (Fig. 191).



Fig 191

PICT-7159

20. Separate the deck engage handle/bolt assembly from the PTO engage lever (manual PTO models) (Fig. 193).



Fig 193

PICT-7165

19. Remove the stop bracket (manual PTO models) (Fig. 192).



Fig 192

PICT-7164

21. Remove the cotter pin from the park brake linkage rod (Fig. 194).



Fig 194

PICT-7166

# CHASSIS

22. Remove the linkage rod from the park brake lever (Fig. 195).



Fig 195

PICT-7168

24. Remove the linkage rod from the cruise control lever (Fig. 197).



Fig 197

PICT-7170

3

23. Remove the cotter pin from the cruise control linkage rod (Fig. 196).



Fig 196

PICT-7169

25. Remove the screws securing the top of the tower to the top of the tower support brackets (Fig. 198).



Fig 198

PICT-7172



26. Remove the 2 screws securing the lower front left and right corners of the tower to the frame (Fig. 199).

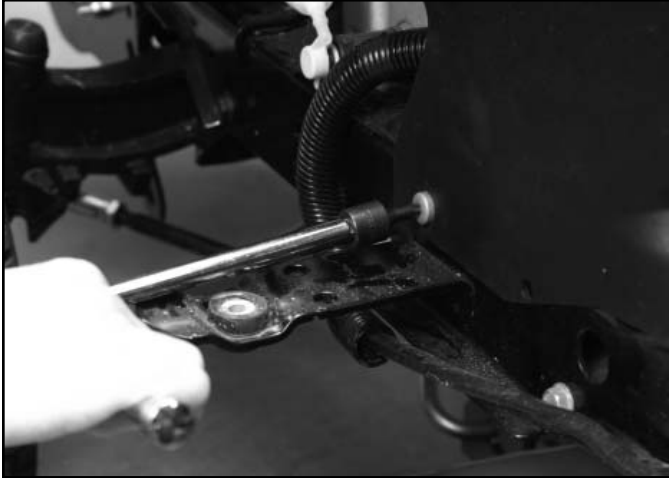

Fig 199

PICT-7198

27. Loosen the 2 bolts securing the lower rear corners of the tower to the frame (Fig. 200).

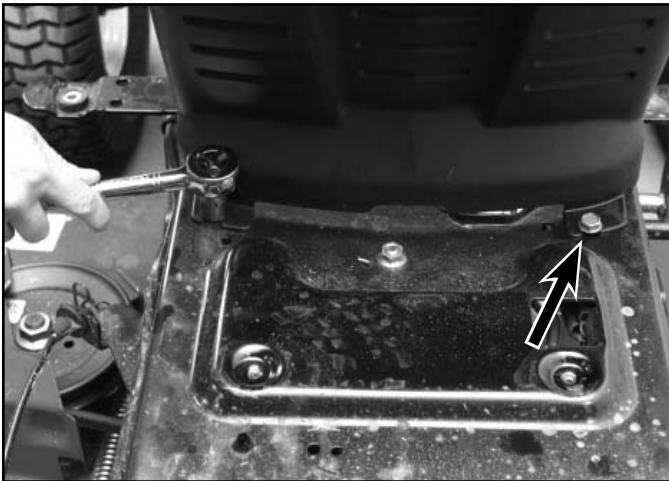

Fig 200

PICT-7174

28. Lift the tower assembly off the frame (Fig. 201).



Fig 201

PICT-7175

29. Remove the PTO knob from the deck engage handle in the tower (Fig. 202).



Fig 202

PICT-7179a

# CHASSIS

30. Remove the deck engage handle from the tower by routing it out the back side of the tower (Fig. 203).



Fig 203

PICT-7182

32. Remove the ignition switch module by depressing the 4 tabs (Fig. 205).



Fig 205

PICT-7186

31. Remove the hour meter from the tower by squeezing the tabs (Fig. 204).



Fig 204

PICT-7184

33. Remove the screw securing the bent lever rod to the back of the tower and then remove the rod/lever assembly from the tower (Fig. 206).



Fig 206

PICT-7188a

34. Remove the 2 screws securing the left tower support to the frame (Fig. 207).

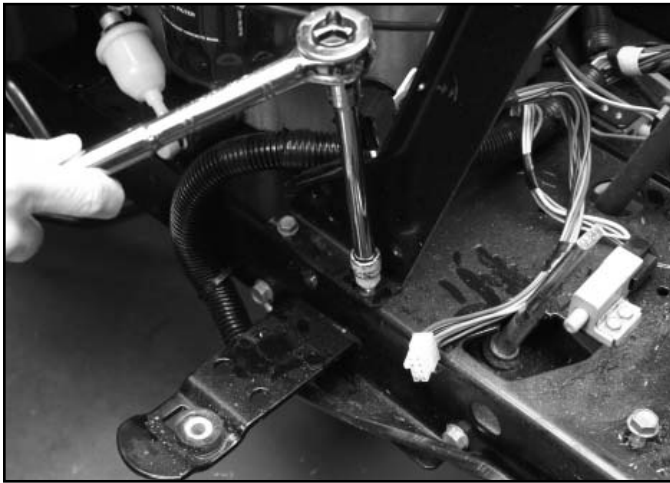

Fig 207

PICT-7191

35. Remove the left tower support from the frame (Fig. 208).



Fig 208

PICT-7192

36. Repeat steps 34 and 35 on the right tower support.

## Installation

1. Position the left tower support onto the frame (Fig. 209).

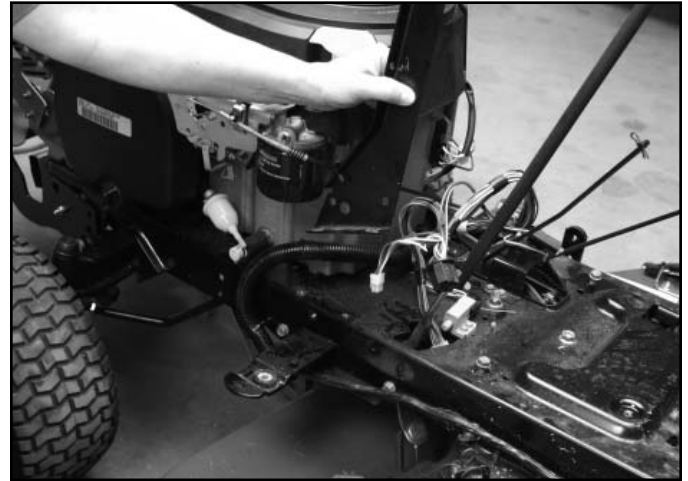

Fig 209

PICT-7194

2. Install 2 screws to secure the support onto the frame (Fig. 210).

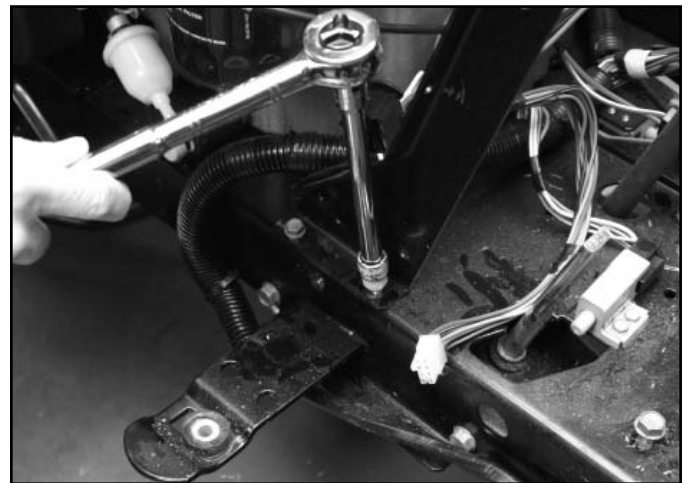

Fig 210

PICT-7191

# CHASSIS

3. Repeat steps 1 and 2 to install the right tower support.
4. Position the bent lever rod into the tower and secure with a screw (Fig. 211).



**Fig 211** PICT-7188a

6. Install the hour meter into the tower (Fig. 213).



**Fig 213** PICT-7184

5. Install the ignition switch module into the tower (Fig. 212).



**Fig 212** PICT-7186

7. Position the deck engage handle into the tower by routing it in through the back side of the tower (Fig. 214).



**Fig 214** PICT-7195

8. Install the PTO knob onto the deck engage handle (Fig. 215).



Fig 215

PICT-7179a

10. Tighten the 2 bolts to secure the lower rear corners of the tower to the frame (Fig. 217).

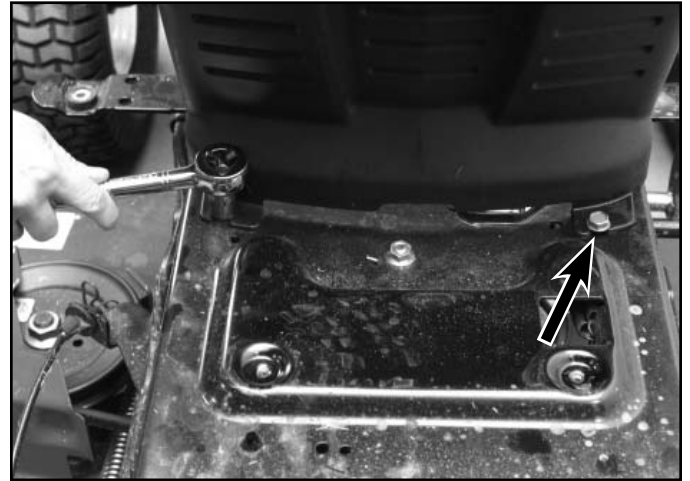

Fig 217

PICT-7174

9. Position the tower assembly so that the 2 tabs on the lower rear corners of the tower are slid under the 2 loose bolts on the frame (Fig. 216).



Fig 216

PICT-7197

11. Install 2 screws to secure the lower front corners of the tower to the frame (Fig. 218).

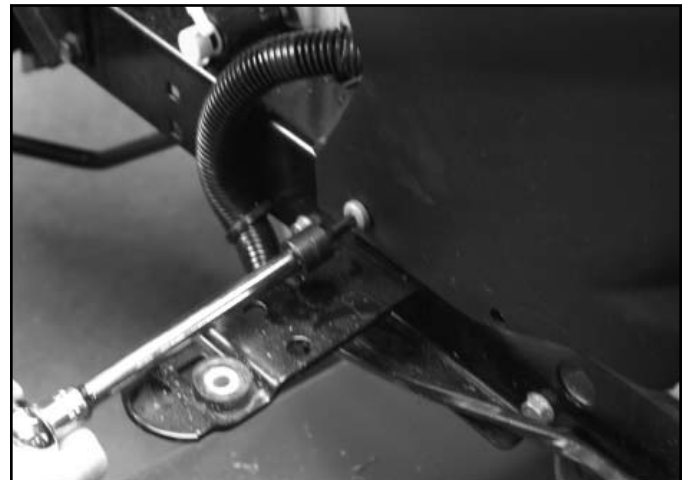

Fig 218

PICT-7173

# CHASSIS

12. Install the screws securing the top of the tower to the top of the tower support brackets (Fig. 219).



Fig 219

PICT-7172

14. Install a cotter pin to secure the rod to the cruise control lever (Fig. 221).



Fig 221

PICT-7169

13. Position the cruise control rod into the cruise control lever (Fig. 220).



Fig 220

PICT-7170

15. Position the park brake rod into the park brake lever (Fig. 222).



Fig 222

PICT-7168

3

16. Install a cotter pin to secure the park brake rod to the park brake lever (Fig. 223).



Fig 223

PICT-7166

18. Assemble the stop bracket onto the deck engagement handle bolts (manual PTO models) (Fig. 225).



Fig 225

PICT-7164a

17. Insert the two bolts on the deck engagement handle assembly into the PTO engage lever (manual PTO models) (Fig. 224).



Fig 224

PICT-7201

19. Install 2 nuts securing the deck engagement handle assembly and stop bracket to the PTO engage lever (manual PTO models) (Fig. 226).



Fig 226

PICT-7200

# CHASSIS

20. Position the throttle/choke assembly into the slot in the tower (Fig. 227).



Fig 227

PICT-7206

22. Slide the control knob onto the throttle/choke assembly (Fig. 229).



Fig 229

PICT-7208

21. Install 2 screws to secure the throttle/choke assembly to the tower (Fig. 228).



Fig 228

PICT-7156

23. Install the bolt and nut securing the control knob to the throttle/choke assembly (Fig. 230).



Fig 230

PICT-7154

3



24. Install the throttle decal onto the tower (Fig. 231).



Fig 231

PICT-7153

26. Plug the ignition switch into the wire harness (Fig. 233).



Fig 233

PICT-7150

25. Install the fuse holder into the dash support (Fig. 232).



Fig 232

PICT-7210

27. Connect the ignition module to the wire harness (Fig. 234).



Fig 234

PICT-7149

# CHASSIS

28. **Electric PTO models:** Plug the electric PTO switch plug into the switch (Fig. 235).

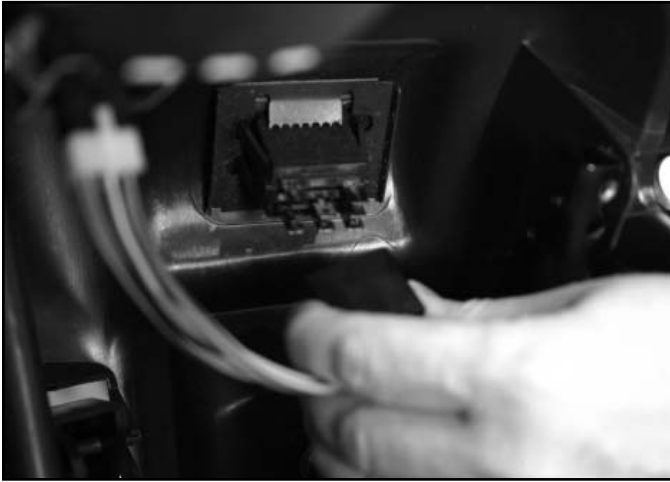

Fig 235

PICT-9826

30. Position the fuel tank into the engine compartment (Fig. 237).



Fig 237

PICT-7146a

29. Plug the hour meter into the wire harness (Fig. 236).

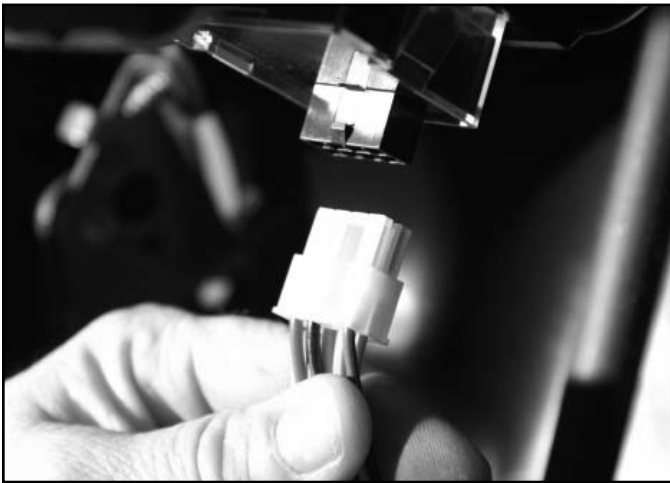

Fig 236

PICT-7148

31. Install two screws securing the fuel tank support rods to the dash supports (Fig. 238).



Fig 238

PICT-7144

32. Install the fender. Refer to "Fender Replacement - Installation" on page 3-39.
33. Connect the fuel line to the fuel filter and secure in place with a hose clamp (Fig. 239).

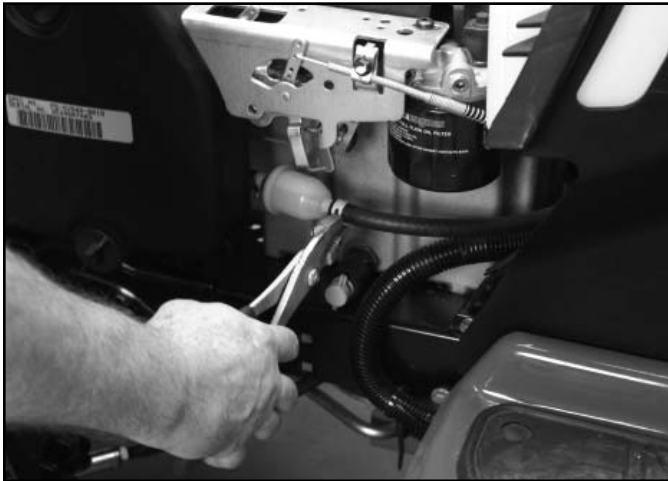

Fig 239

PICT-7094

34. With the front wheels pointing straight ahead, position the steering wheel onto the steering shaft (Fig. 240).



Fig 240

PICT-7143

35. Install the washer and secure the steering wheel to the steering shaft with a bolt (Fig. 241).



Fig 241

PICT-7142

36. Install the steering wheel cap (Fig. 242).



Fig 242

PICT-7106

37. Start the machine.
38. Operate all controls and test the interlock system to ensure proper operation.

# CHASSIS

## Lower Transmission Drive Belt Replacement - Gear Drive Models

### Removal

1. Remove the mower deck: 42" deck on page 7-64; 46" deck on page 7-69; 50" deck on page 7-74.
2. Remove the upper transmission drive belt. See "Upper Transmission Drive Belt Replacement - Removal" on page 3-67.
3. Electric PTO models: Remove the electric PTO clutch. Refer to "Electric PTO Clutch Replacement - Removal" on page 3-27.
4. Raise the machine to access the belt.
5. Remove the bolt securing the belt keeper rod to the chassis (Fig. 243).



Fig 243

PICT-7296

6. Remove the belt keeper rod (Fig. 244).



Fig 244

PICT-7301

7. Secure the engine pulley and remove the crankshaft bolt and washer (Fig. 245).



Fig 245

PICT-7302

8. While sliding the pulley off the crankshaft, slip the lower transmission drive belt off the pulley (Fig. 246).



Fig 246

PICT-7305

10. **Electric PTO models:** Slide the engine pulley off the crankshaft. While sliding the pulley off the crankshaft remove the belt from the pulley. (Fig. 248).



Fig 248

PICT-7305

9. Remove the pulley from the crankshaft (Fig. 247).



Fig 247

PICT-7306

11. Remove the belt guide (bolt and spacer) from the frame. It must be accessed through the steering support bracket (Fig. 249).



Fig 249

PICT-7308

# CHASSIS

12. Remove the belt from around the crankshaft and feed it back toward the rear of the machine, removing it from the double idler pulleys (Fig. 250).



Fig 250

PICT-7309

13. Remove the lower transmission drive belt from the variable speed pulley and pull it out of the machine (Fig. 251).



Fig 251

PICT-7311

## Installation

1. Route the lower transmission drive belt into the variable speed pulley by lifting up on the middle section of the pulley and placing the belt into the lower groove of the pulley (Fig. 252).



Fig 252

PICT-7312

2. Continue routing the belt forward above the steering support bracket and then up around the crankshaft (Fig. 253).

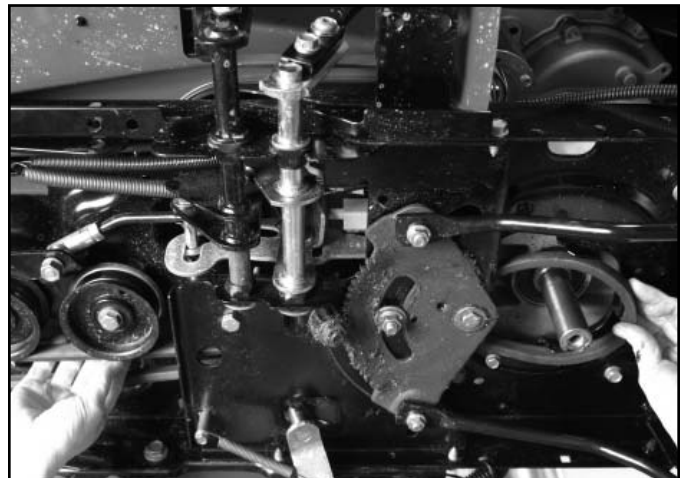

Fig 253

PICT-7314

3. Apply anti-seize compound to the crankshaft (Fig. 254).



Fig 254

PICT-7315

5. While sliding the engine pulley onto the crankshaft, slip the lower transmission drive belt onto the engine pulley (Fig. 256).



Fig 256

PICT-7317

4. **Electric PTO models:** Slide the engine pulley onto the crankshaft. While sliding the pulley up, route the belt around the pulley (Fig. 255).



Fig 255

PICT-9828

6. Install the crankshaft bolt and washer securing the engine pulley to the crankshaft. Torque the bolt to 37.5 to 50 ft-lbs. (50.84 to 67.79 Nm) (Fig. 257).



Fig 257

PICT-7328

# CHASSIS

7. Install the rod end of the keeper rod into the frame. Secure the keeper rod by installing a bolt through the loop end and into the frame (Fig. 258).



Fig 258

PICT-7318

8. Install the belt guide (bolt and spacer) to the frame through the steering support bracket. Ensure the belt is routed to the right of the belt guide (Fig. 259).



Fig 259

PICT-7331

9. Route the belt around the double idler pulleys (Fig. 260).

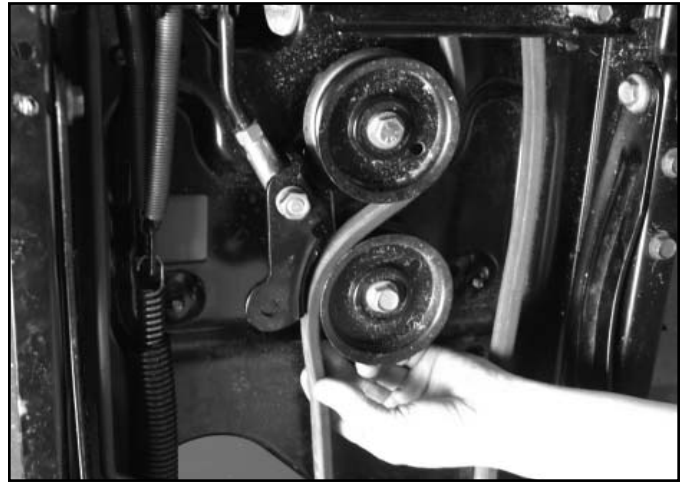

Fig 260

PICT-7332

10. **Electric PTO models:** Install the electric PTO clutch onto the crankshaft. Refer to "Electric PTO Clutch Replacement - Installation" on page 3-28.
11. Lower the machine.
12. Install the upper transmission drive belt. See "Upper Transmission Drive Belt Replacement - Installation" on page 3-69.
13. Install the mower deck: 42" deck on page 7-67; 46" deck on page 7-72; 50" deck on page 7-76.



## Upper Transmission Drive Belt Replacement - Gear Drive Models

The mower deck has been removed for photo purposes.

### Removal

1. Disconnect the negative battery cable and then the positive battery cable.
2. Remove the battery hold down strap (Fig. 261).

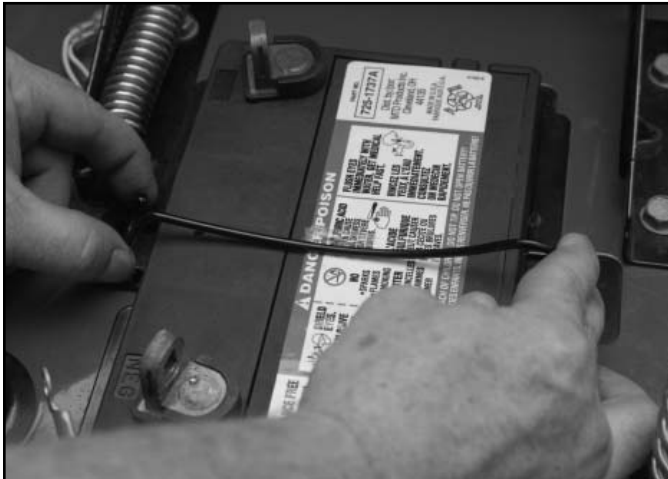

Fig 261

PICT-7109a

3. Remove the battery from battery compartment (Fig. 262).



Fig 262

PICT-7276

4. Remove the battery tray (Fig. 263).



Fig 263

PICT-7277

# CHASSIS

5. Place a strap around the idler arm. Pull on the strap and secure it so that tension is released from the belt (Fig. 264).

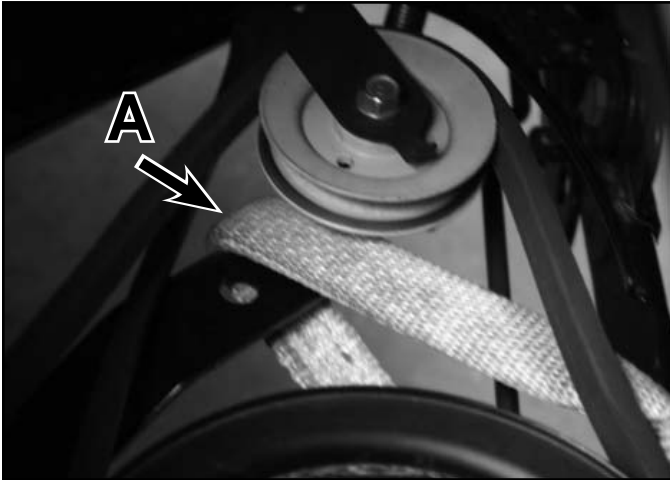

Fig 264

PICT-7280

- A. Strapped idler arm

6. Using a screwdriver, secure the transmission pulley through the vent hole. Remove the nut that secures the transmission pulley to the transmission (Fig. 265).

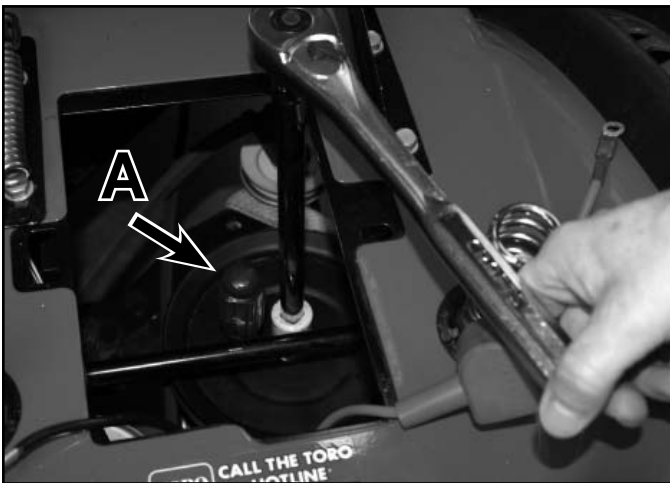

Fig 265

PICT-7282

- A. Screwdriver

7. Remove the transmission pulley from the transmission (Fig. 266).



Fig 266

PICT-7283

8. Remove the belt from the top groove of the variable speed pulley (Fig. 267).



Fig 267

PICT-7287a

9. Remove the upper transmission drive belt from the idler pulley and remove it from the machine (Fig. 268).

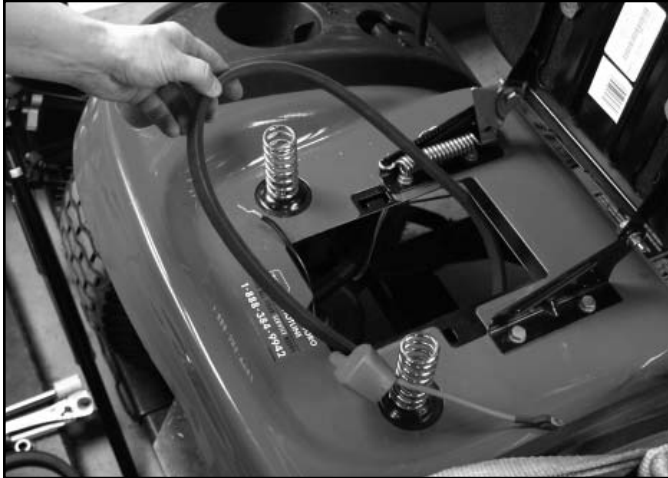

Fig 268

PICT-7284

2. Route the belt into the top groove of the variable speed pulley (Fig. 270).



Fig 270

PICT-7287a

## Installation

1. Secure the idler arm with a strap so the belt will not be under tension during installation. Install the upper transmission drive belt onto the idler pulley (Fig. 269).



Fig 269

PICT-7286a

3. Position the transmission pulley above the transmission and rout the upper transmission belt around it. Engage the grooves in the pulley with the splines of the transmission pulley hub (Fig. 271).



Fig 271

PICT-7289a

# CHASSIS

4. With a screwdriver inserted through the pulley vent hole, secure the transmission pulley to the transmission with a nut. Torque the nut to 35-33 ft-lbs. (33.9-44.7 Nm) (Fig. 272).

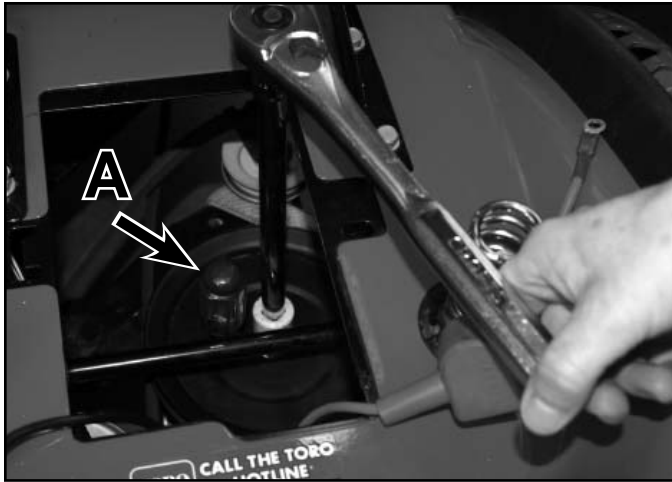

Fig 272

PICT-7282

- A. Screwdriver

5. Remove the strap securing the idler pulley.
6. Install the battery tray (Fig. 273).



Fig 273

PICT-7277

7. Place the battery into the battery compartment (Fig. 274).



Fig 274

PICT-7276

8. Install the battery hold down strap (Fig. 275).



Fig 275

PICT-7497

9. Connect the positive battery cable and then the negative battery cable.

## Transmission Drive Belt (Hydro) Replacement

### Removal

1. Remove the mower deck. Refer to "46" Mower Deck Removal" on page 7-69.
2. Disconnect the negative battery cable (Fig. 276).



Fig 276

PICT-7494

3. Disconnect the positive battery cable (Fig. 277).



Fig 277

PICT-7495

4. Remove the battery hold down strap (Fig. 278).



Fig 278

PICT-7109a

5. Lift the battery out of the battery tray (Fig. 279).



Fig 279

PICT-7499

# CHASSIS

6. Remove the battery tray (Fig. 280).

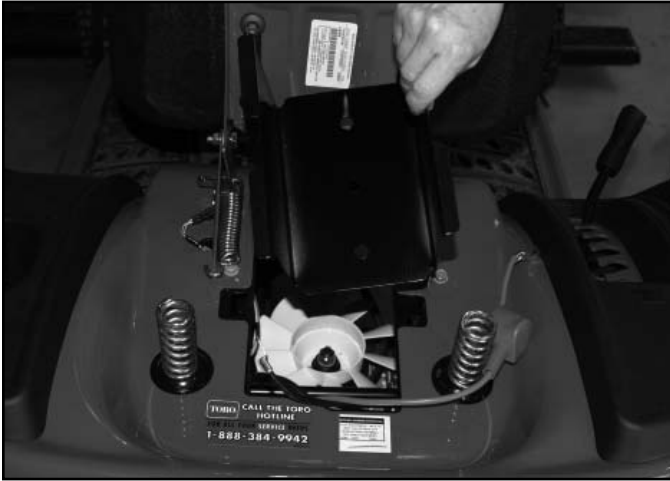

Fig 280

PICT-7500

8. Remove the transmission drive belt from the fixed V idler (Fig. 282).



Fig 282

PICT-7508

7. Remove tension from the center double idler bracket and remove the transmission drive belt from the idler pulley (Fig. 281).

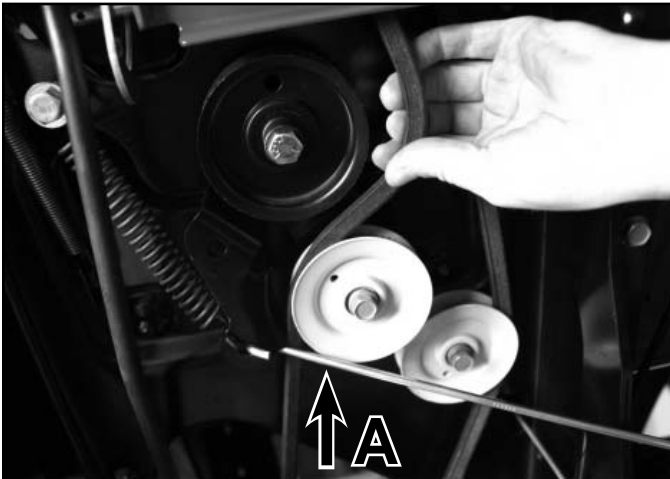

Fig 281

PICT-7505

9. Secure the engine pulley and remove the bolt and washer retaining it to the crankshaft (Fig. 283).

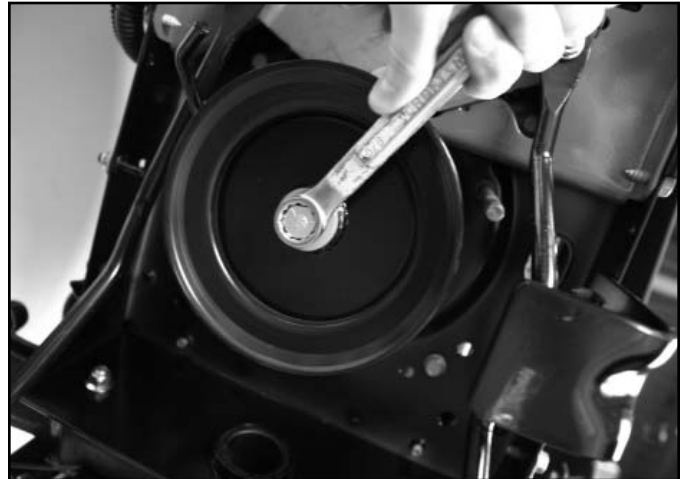

Fig 283

PICT-7507

- A. Spring removal tool

10. Begin sliding the engine pulley down the crankshaft and remove the transmission drive belt from the pulley (Fig. 284).



Fig 284

PICT-7510

11. Remove the transmission drive belt from around the crankshaft (Fig. 285).



Fig 285

PICT-7514

12. Remove the transmission drive belt from above the steering support bracket (Fig. 286).

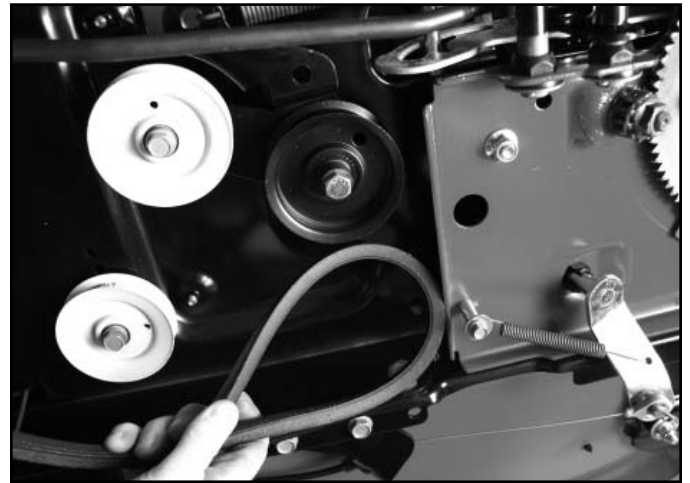

Fig 286

PICT-7515

13. Remove the transmission drive belt from around the transmission pulley and fan and remove it from the machine (Fig. 287).



Fig 287

PICT-7518

# CHASSIS

## Installation

1. Position the transmission belt around the transmission fan pulley (Fig. 288).



Fig 288

PICT-7583

2. Route the belt between the frame and the steering support bracket (Fig. 289).

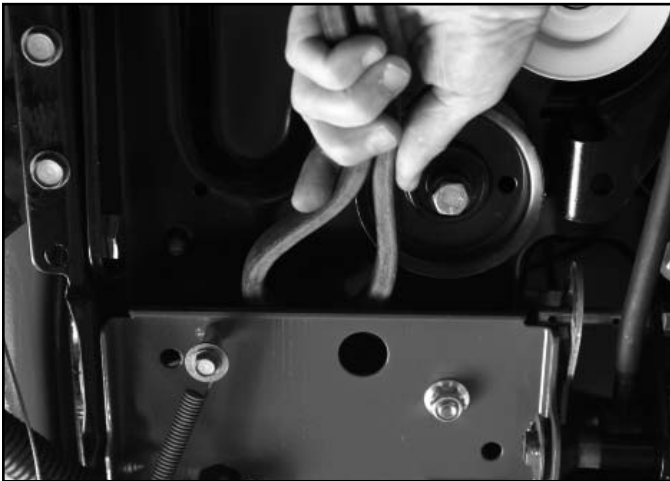

Fig 289

PICT-7587

3. Continue routing the belt forward and position it around the crankshaft (Fig. 290).

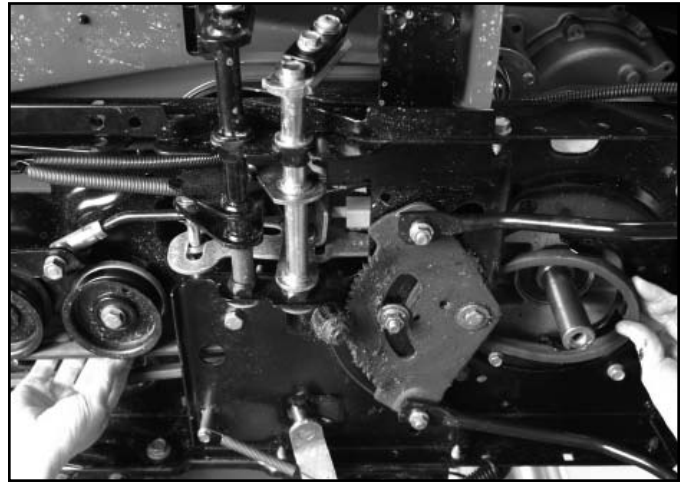

Fig 290

PICT-7314

4. Apply anti-seize compound to the crankshaft (Fig. 291).

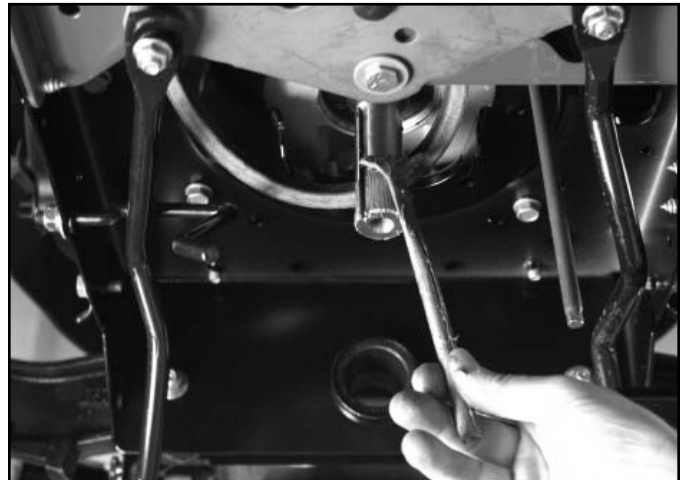

Fig 291

PICT-7589



5. Align the key of the engine pulley with the keyway on the crankshaft. Slide the engine pulley onto the crankshaft and install the transmission belt onto the pulley (Fig. 292).



Fig 292

PICT-7590

6. Install a bolt and washer to secure the engine pulley to the crankshaft and torque to 37.5 to 50 ft-lbs. (50.84 to 67.79 Nm) (Fig. 293).



Fig 293

PICT-7328

7. Route the transmission drive belt around the fixed V-idler pulley (Fig. 294).



Fig 294

PICT-7594

8. Remove tension from the center double idler bracket and install the transmission drive belt around the idlers (Fig. 295).



Fig 295

PICT-7595

# CHASSIS

9. Install the mower deck. Refer to “46” Mower Deck Installation” on page 7-72.
10. Install the battery tray (Fig. 296).



Fig 296

PICT-7500

12. Install the battery hold down strap (Fig. 298).



Fig 298

PICT-7497

11. Position the battery into the battery tray (Fig. 297).



Fig 297

PICT-7499

13. Connect the positive battery cable (Fig. 299).



Fig 299

PICT-7495

14. Connect the negative battery cable (Fig. 300).



Fig 300

PICT-7494

15. Purge the system. Refer to "Purging the System" on page 3-82.
16. Check the neutral adjustment. Refer to "Neutral Adjustment" on page 3-84.
17. Check the brake adjustment. Refer to "Brake Adjustment" on page 3-91.

## Variable Speed Pulley Replacement

The mower deck has been removed for photo purposes.

## Removal

1. Disconnect the negative battery cable and then the positive battery cable.
2. Remove the battery hold down strap (Fig. 301).



Fig 301

PICT-7109a

3. Remove the battery from battery compartment (Fig. 302).



Fig 302

PICT-7276

# CHASSIS

4. Remove the battery tray (Fig. 303).



Fig 303

PICT-7277

6. Slip both the lower and upper belts off the variable speed pulley (Fig. 305).



Fig 305

PICT-7346

5. Place a strap around the idler arm. Pull on the strap and secure it so that tension is released from the belt (Fig. 304).

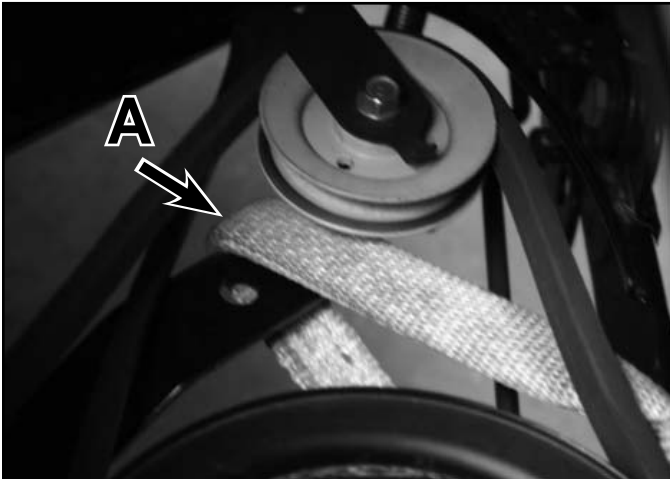

Fig 304

PICT-7280

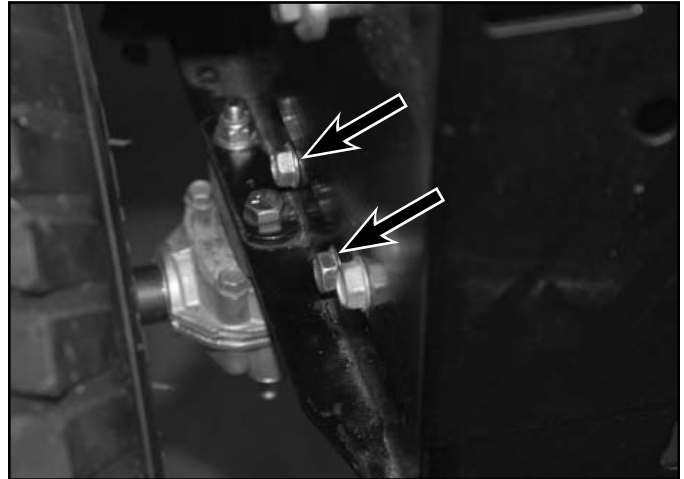

Fig 306

PICT-7333a

- A. Strapped idler arm

- Slide the variable speed pulley off the transmission shaft (Fig. 307).



Fig 307

PICT-7339

- Position the variable speed pulley with the bracket up against the frame and install the 2 bolts (Fig. 309).



Fig 309

PICT-7333a

## Installation

- Place the variable speed pulley onto the transmission shaft and install the upper and lower belts onto the pulley (Fig. 308).



Fig 308

PICT-7346

- Release the strapped idler arm making sure the belt is in the idler pulley groove (Fig. 310).



Fig 310

PICT-7280

# CHASSIS

4. Install the battery tray (Fig. 311).



Fig 311

PICT-7277

6. Install the battery hold down strap (Fig. 313).



Fig 313

PICT-7497

5. Place the battery into the battery compartment (Fig. 312).



Fig 312

PICT-7276

7. Connect the positive battery cable (Fig. 314).



Fig 314

PICT-7495

8. Connect the negative battery cable (Fig. 315).



Fig 315

PICT-7494

2. Remove the 3 bolts securing the bearing cup to the pulley bracket (Fig. 317).



Fig 317

PICT-7342

## Variable Speed Pulley Service

### Disassembly

1. Remove the center bolt and washer securing the bearings to the pulley shaft (Fig. 316).



Fig 316

PICT-7340

3. Remove the bearing cup (Fig. 318).



Fig 318

PICT-7343

# CHASSIS

4. Remove the 2 ball bearings (Fig. 319).



Fig 319

PICT-7344

5. Remove the pulley bracket (Fig. 320).

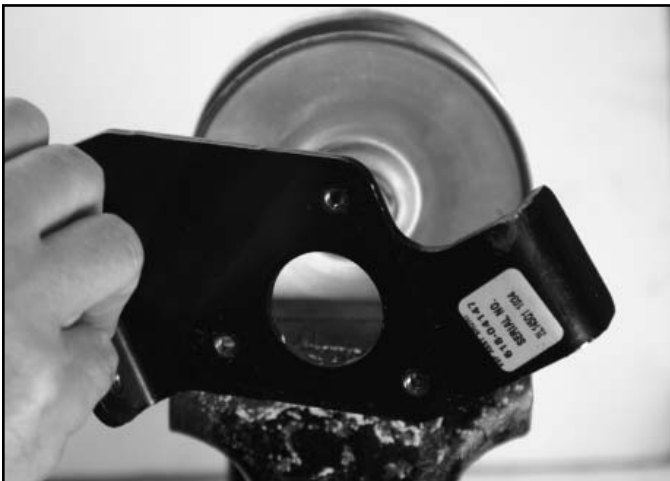

Fig 320

PICT-7345

6. Inspect the bearings for wear and damage. Replace if necessary.

## Assembly

Assemble the variable speed pulley assembly in reverse order of disassembly.

## Purging the System - Hydrostatic Models

Due to the effect air has on efficiency in hydrostatic drive applications, it is critical that it be purged from the system.

These purge procedures should be implemented any time a hydrostatic system has been opened to facilitate maintenance or any additional oil has been added to the system.

Air creates inefficiency because its compression and expansion rate is higher than the oil in hydrostatic drive systems.

The resulting symptoms in hydrostatic systems may be:

1. Noisy operation
2. Lack of power or drive after short term operation
3. High operation temperature and excessive expansion of oil



Before starting, make sure the transaxle is at the specified oil level (Fig. 321).

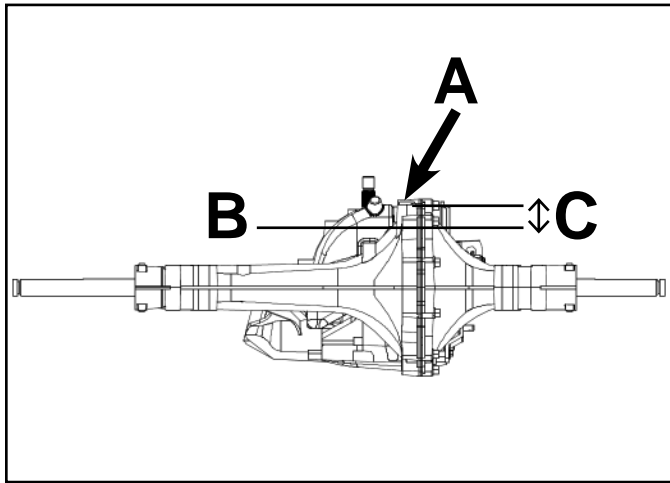

**Fig 321** fig. 4 310-0510 IHTa

- A. Fill port
- B. Oil level
- C. 1-1/4" (31.75mm) max. depth at 50°-100° F (10°-38° C)

The following procedures should be performed with the vehicle drive wheels off the ground, then repeated under normal operating conditions.

1. With the bypass valve open and the engine running, slowly move the directional control (foot control) in both forward and reverse directions 5 to 6 times; as air is purged from the unit, the oil level will drop.
2. With the bypass valve in the closed position and the engine running, slowly move the directional control valve (foot control) in both forward and reverse directions 5 to 6 times. After stopping the engine, check the oil level and add oil as required.
3. It may be necessary to repeat Steps 1 and 2 until all the air is completely purged from the system. When the transaxle moves forward and reverse at normal speed purging is complete.

## Fluid Change - Hydrostatic Models

The Hydro-Gear transaxle is factory filled, sealed and does not require oil maintenance. However, in the event of oil contamination or degradation, oil replacement may correct certain performance problems. Remove the transaxle from the vehicle and completely drain the oil from the top fluid fill port. Refill unit as near the top of fill port as is practical. Tipping the unit forward, backward and from side to side will allow air to escape. The tipping and filling activity may need to be repeated several times. Refer to the oil fill range (Fig. 322).

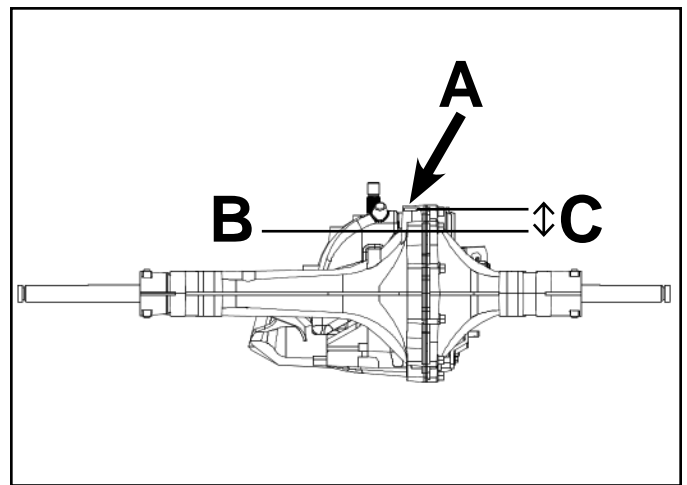

**Fig 322** fig. 4 310-0510 IHTa

- A. Fill port
- B. Oil level
- C. 1-1/4" (31.75mm) max. depth at 50°-100° F (10°-38° C)

Reinstall transaxle and perform purging procedures. If the oil drained from the transaxle is severely contaminated or overheated, the transaxle should be disassembled for inspection, cleaning, and repair, as needed.

Fluid Description	Volume
20W-50 engine oil	79 fl. oz. (2336ml)

# CHASSIS

## Neutral Adjustment - Hydrostatic Models

Before making a neutral adjustment, the transmission must be warmed up for at least 10 minutes.

1. Loosen the bolt and washer retaining the right side wheel to the right side axle (Fig. 323).



Fig 323

PICT-7221

2. Raise and support the right rear end of the tractor to permit removing the right rear tire. Make sure the left rear tire stays on the ground.

3. Remove the bolt, washer and wheel assembly from the right axle (Fig. 324).



Fig 324

PICT-7597

4. Locate the neutral adjusting puck and loosen the Allen head bolt. If it's difficult to loosen, heat the aluminum housing near the bolt with a propane torch (Fig. 325).

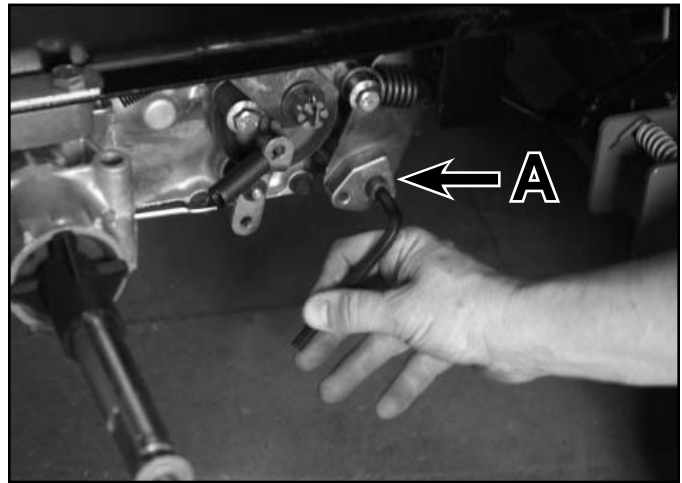

Fig 325

PICT-7599

- A. Adjusting puck

5. Start the engine and run it at full throttle.
6. Rotate the adjusting puck in both directions and watch the axle direction. Adjust the puck so it is set at the midpoint between forward and reverse axle rotation. Make sure the axle is not moving.
7. Once in neutral, hold the puck with an adjustable wrench so it won't move. Tighten the Allen head bolt (Fig. 326).



Fig 326

PICT-7600

8. Operate the foot control in forward and reverse. Allow the pedal to return to the neutral position to test the adjustment.

## Front Wheel Toe-in Measurement

If there is uneven tire wear, lawn scuffing, or hard steering, toe-in may need to be adjusted. The front toe-in measurement should be  $1/16''$  to  $5/16''$  (1.58 to 7.93mm). This should be checked every 100 hours or once a year, whichever occurs first.

### MEASUREMENT:

1. Disengage the PTO, set the parking brake, and turn the ignition key to OFF to stop the engine. Remove the key.
2. Pull the front of the tires out to remove normal looseness in the linkage (Fig. 327).



Fig 327

PICT-7820

# CHASSIS

3. Measure the distance between the front rims at steering axle level (front and rear of the wheels).

**Note:** You can also measure between the tread mold marks if the tires are new (Fig. 328 - front and Fig. 329 - rear).



Fig 328

PICT-7821



Fig 329

PICT-7828

4. The front measurement should be  $1/16''$  to  $5/16''$  (1.58mm to 7.93mm) less than the rear measurement. If needed, follow the adjustment procedures:

## Front Wheel Toe-in Adjustment

1. Remove the tie rod from one steering arm (Fig. 330).



Fig 330

PICT-7830

2. Loosen the jam nut securing the ball joint to the steering rod (Fig. 331).



Fig 331

PICT-7831

3. Rotate the ball joint one turn: clockwise to increase toe-in; counterclockwise to decrease toe-in (Fig. 332).

**IMPORTANT:** If more than one turn is required to meet specifications, alternate between the right and left steering rods to maintain steering wheel alignment.



Fig 332

PICT-7833

4. Tighten the jam nut to secure the position of the ball joint to the steering rod (Fig. 333).



Fig 333

PICT-7831

5. Install the ball joint to the steering arm and check the toe-in as described in the measurement section.

## Autodrive Pedal Adjustment - Hydrostatic Models

1. Remove the mower deck. Refer to "46" Mower Deck Removal" on page 7-69.
2. The Autodrive pedal is properly adjusted when the hole found in the double idler bracket has approximately 1-3/8" (3.5cm) of travel with 10 lbs. (4.5kg) of pressure applied to the Autodrive pedal (Fig. 334 and Fig. 335).



Fig 334

PICT-7670

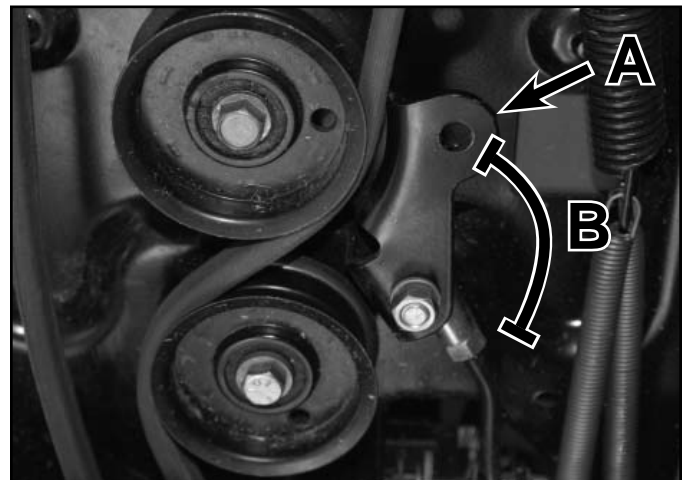

Fig 335

PICT-7673a

- A. Double idler bracket    B. 1-3/8" ravel distance

# CHASSIS

3. If adjustment is needed:
4. Locate the speed control assembly on the underside of the steering support bracket (Fig. 336).

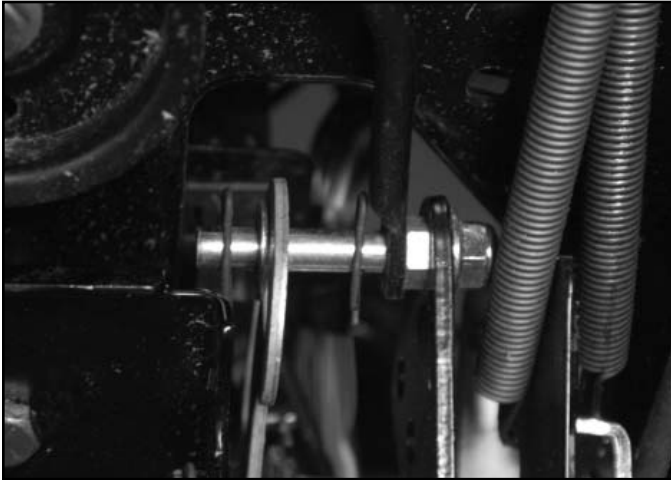

Fig 336

PICT-7682a

6. Remove the washer from the speed control assembly (Fig. 338).



Fig 338

PICT-7683

5. Remove both hairpin cotters from the main pin on the speed control assembly (Fig. 337).

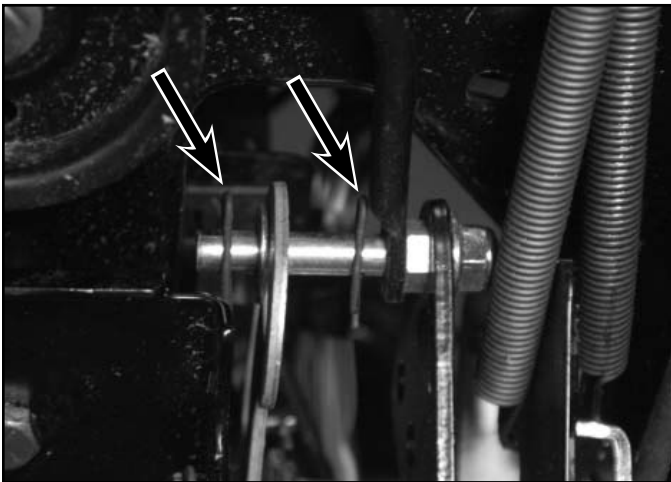

Fig 337

PICT-7682a

7. Remove the Autodrive pedal return spring (Fig. 339).



Fig 339

PICT-7684

8. Remove the lock nut from the main pin (Fig. 340).

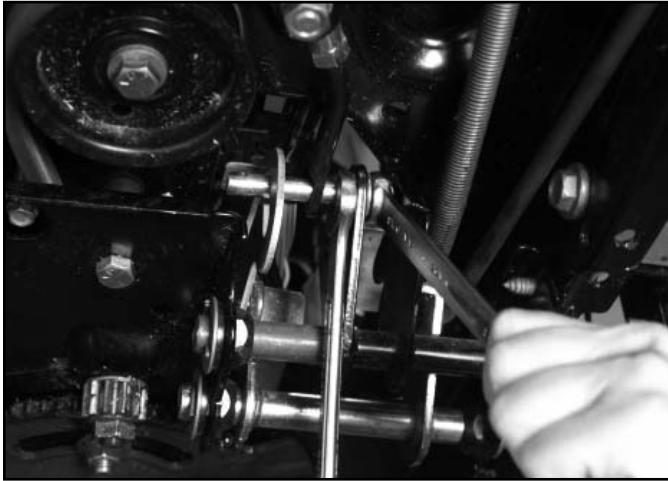

Fig 340

PICT-7691

9. Remove the main pin from the speed control assembly (Fig. 341).

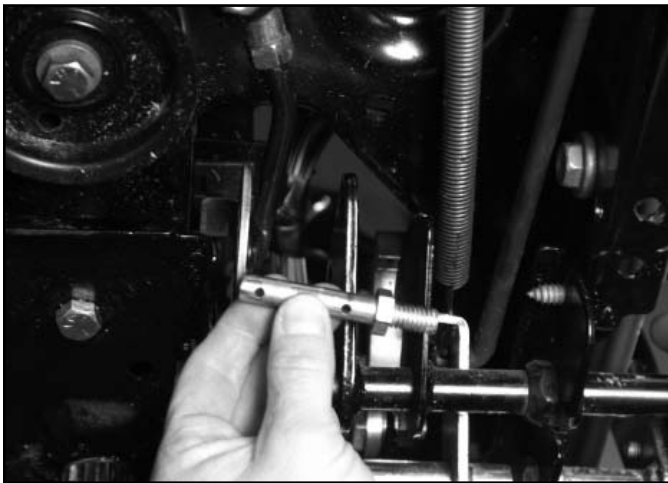

Fig 341

PICT-7692

10. Loosen the jam nut on the idler adjustment rod. Turn the idler adjustment rod clockwise or counter-clockwise until the proper adjustment has been achieved (Fig. 342).

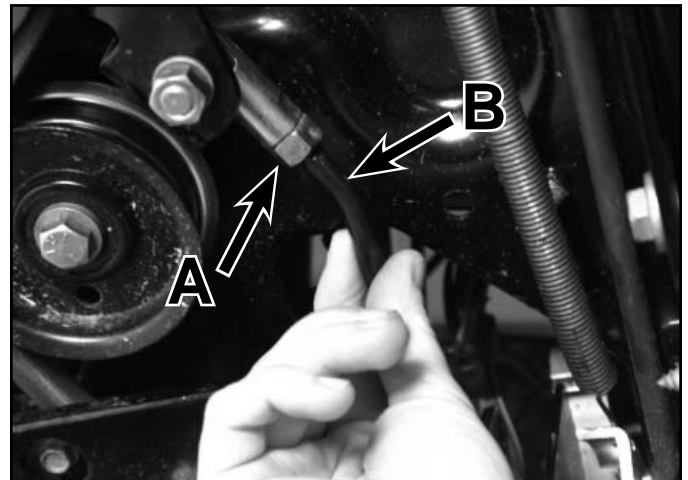

Fig 342

PICT-7693

A. Jam nut

B. Idler adjustment rod

11. Tighten the jam nut.

# CHASSIS

12. Install the main pin through the adjustment rod, back into the lockout bracket, then through the speed control assembly. Install the jam nut onto the pin (Fig. 343).

**Note:** Ensure the main pin is oriented so the hairpin holes are positioned vertically.

3

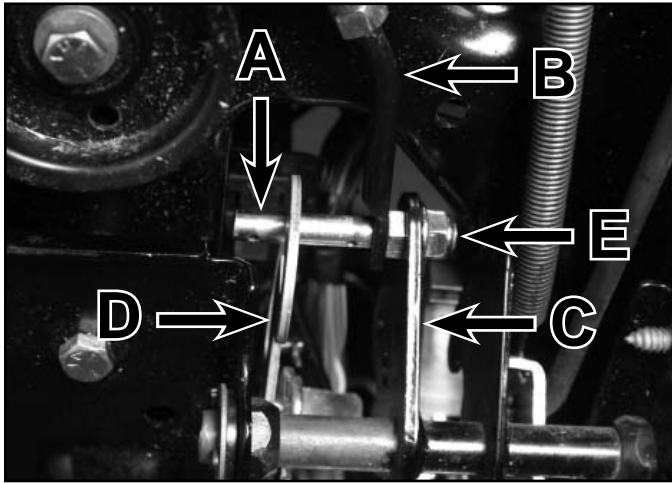

Fig 343 PICT-7699

- A. Main pin
- B. Adjustment rod
- C. Lockout bracket
- D. Speed control assembly
- E. Jam nut

13. Install a washer onto the main pin (Fig. 344).



Fig 344 PICT-7683

14. Install 2 hairpin cotters into the main pin (Fig. 345).

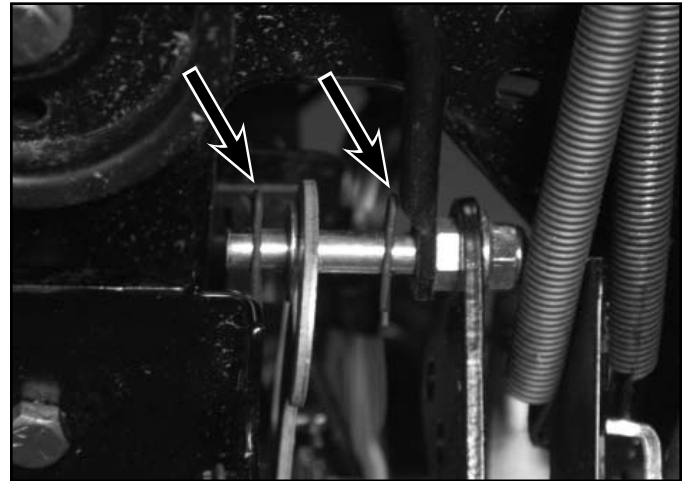

Fig 345 PICT-7682a

15. Install the Autodrive pedal return spring into the notch on the speed control bracket (Fig. 346).

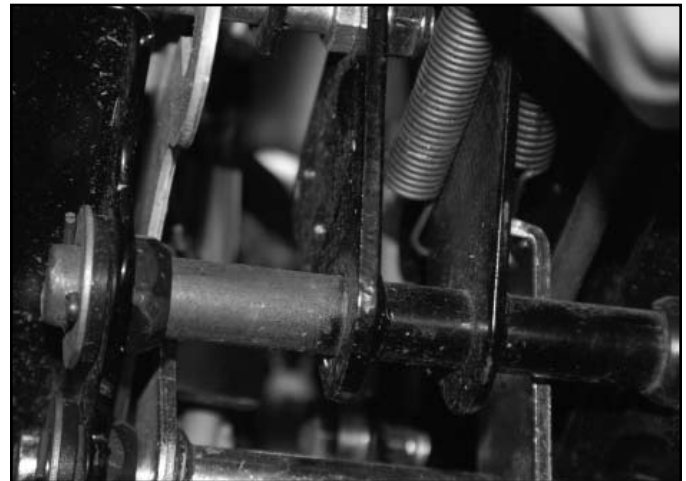

Fig 346 PICT-7687a



16. Install the other end of the Autodrive pedal return spring to the tab on the frame (Fig. 347).

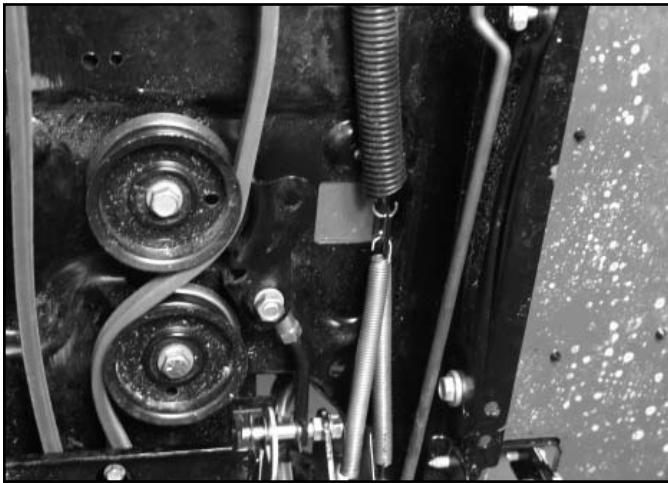

Fig 347

PICT-7704

17. Check the travel distance on the idler bracket (approximately 1-3/8" (3.5cm) of travel with 10 lbs. (4.5kg) of pressure applied to the Autodrive pedal). If additional adjustment is needed, go back to step 3 and repeat adjustment.
18. Install the mower deck. Refer to "46" Mower Deck Installation" on page 7-72.

## Brake Adjustment - Hydrostatic Models

1. Loosen the bolt retaining the right rear wheel to the axle (Fig. 348).



Fig 348

PICT-9609

2. Raise and support the right rear end of the tractor. Make sure the left rear tire stays on the ground.
3. Remove the bolt, washer and wheel assembly from the right axle (Fig. 349).



Fig 349

PICT-7597

# CHASSIS

4. Remove the cotter pin securing the brake adjusting nut (Fig. 350).



Fig 350

PICT-7605

6. Tighten or loosen the brake adjusting nut until slight resistance is felt on the feeler gauge when sliding it in and out (Fig. 352).

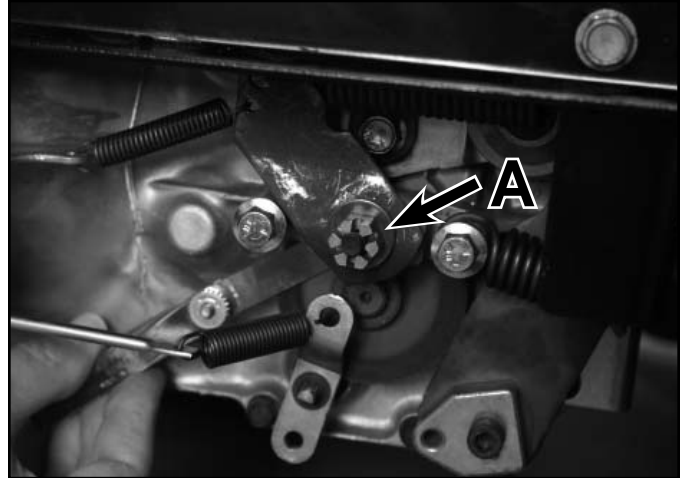

Fig 352

PICT-7606

5. Insert a 0.015 in. (.38mm) feeler gauge between the brake disc and brake puck (Fig. 351).



Fig 351

PICT-7606

- A. Feeler gauge

7. Install a new cotter pin (Fig. 353).



Fig 353

PICT-7605

8. Install tire and check the brake operation again. If satisfactory brake adjustment/operation cannot be attained, the brake pads require service. Refer to the Brake Maintenance section of Hydro-Gear manual 310-0510.
9. With the parking brake released and the bypass lever in push mode, the rear wheels must rotate freely when you push the unit. If they do not rotate freely, repeat steps 1 through 8 above.

## Throttle/Choke Cable Replacement

### Removal

**Note:** The steering wheel has been removed for photo purposes.

1. Raise the hood (Fig. 354).



Fig 354

PICT-7063a

2. Disconnect the fuel line from the fuel filter and drain all the fuel from the fuel tank into an approved container (Fig. 355).

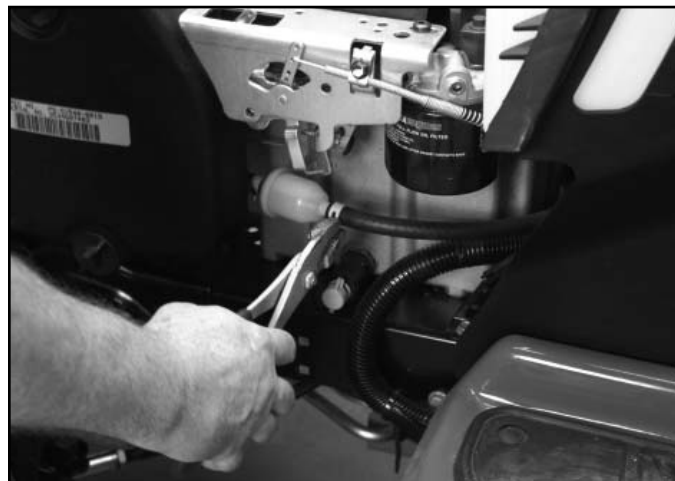

Fig 355

PICT-7094

3. Remove the two screws securing the fuel tank support rods to the tower supports (Fig. 356).



Fig 356

PICT-7099a

# CHASSIS

4. Remove the fuel tank from the tower/engine compartment (Fig. 357).



Fig 357

PICT-7100a

6. Remove the throttle/choke cable from the clamp (Fig. 359).



Fig 359

PICT-7376

5. Locate the speed control assembly on the left side of the engine. Loosen the throttle/choke cable clamp (Fig. 358).



Fig 358

PICT-9635

7. Unhook the z-bend of the throttle/choke control cable from the speed control lever (Fig. 360).



Fig 360

PICT-7379

8. Remove the throttle/choke decal from the tower (Fig. 361).



Fig 361

PICT-7153

10. Remove the control knob (Fig. 363).



Fig 363

PICT-7155

9. Remove the bolt and nut securing the throttle/choke control knob to the throttle/choke assembly (Fig. 362).

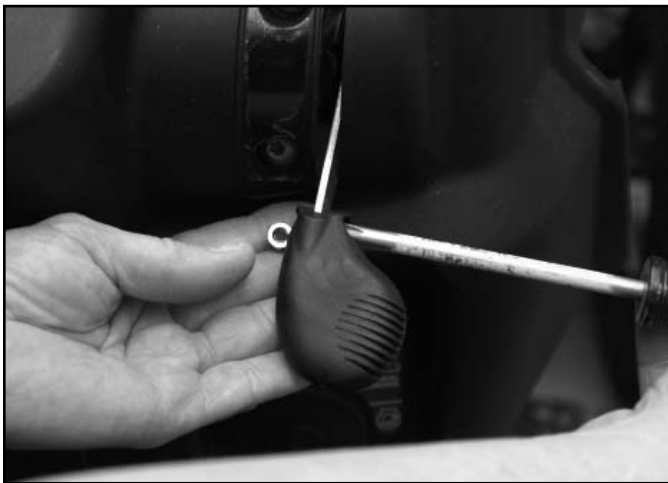

Fig 362

PICT-7154

11. Remove the 2 screws securing the throttle/choke assembly to the tower (Fig. 364).



Fig 364

PICT-7156

# CHASSIS

12. Pull the throttle/choke assembly out from the rear of the tower and remove it from the machine (Fig. 365).



Fig 365

PICT-7158

2. Route the throttle/choke cable around the engine to the back side of the tower (Fig. 367).



Fig 367

PICT-9638a

## Installation

1. Hook the z-bend of the throttle/choke control cable into the second hole from the top of the speed control lever (Fig. 366).



Fig 366

PICT-9637

3. Insert the throttle/choke assembly lever into the slot from the rear of the tower and install 2 screws to secure the throttle/choke assembly to the tower (Fig. 368).



Fig 368

PICT-9640

- Slide the control knob onto the throttle/choke control lever (Fig. 369).



Fig 369

PICT-9641

- Apply a throttle/choke decal onto the tower, over the 2 screws securing the throttle/choke assembly (Fig. 371).



Fig 371

PICT-9643

- Install a bolt and nut to secure the control knob to the throttle/choke assembly (Fig. 370).



Fig 370

PICT-9642

- Move the throttle/choke control lever to the "CHOKE" position (Fig. 372).



Fig 372

PICT-9644

# CHASSIS

8. Remove the air cleaner cover and air cleaner from the engine (Fig. 373).

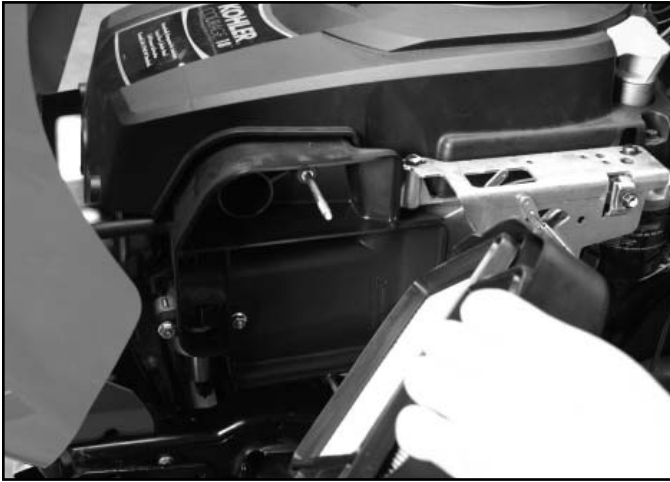

Fig 373

PICT-9645

10. Position the speed control lever into the choke position (all the way back) (Fig. 375).



Fig 375

PICT-9648

9. Position the throttle/choke cable into the cable clamp (Fig. 374).



Fig 374

PICT-9646

- Note: The choke should be closed in the carburetor (Fig. 376).**

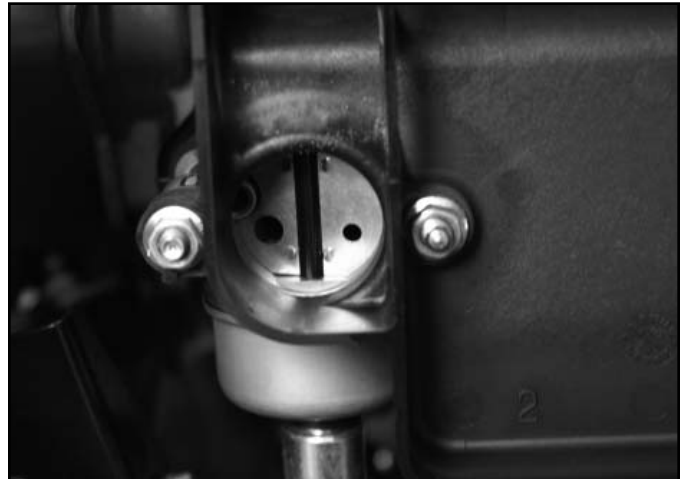

Fig 376

PICT-9649



11. Tighten the cable clamp securing the cable position (Fig. 377).



Fig 377

PICT-9650

- Note:** The choke should be open in the carburetor (Fig. 379).

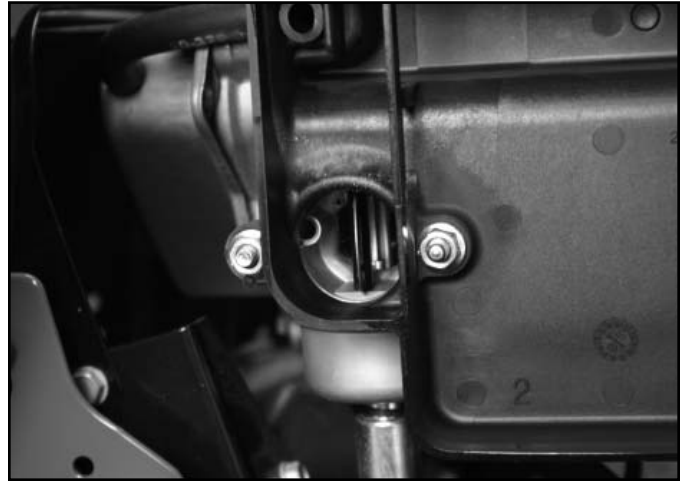

Fig 379

PICT-9663

12. Position the throttle/choke control lever to the detent in the "FAST" position (Fig. 378).



Fig 378

PICT-9653

13. Install the air cleaner and air cleaner cover (Fig. 380).



Fig 380

PICT-9651

# CHASSIS

14. Position the fuel tank into the engine compartment (Fig. 381).



Fig 381

PICT-7100a

16. Connect the fuel line to the fuel filter and secure with a hose clamp (Fig. 383).

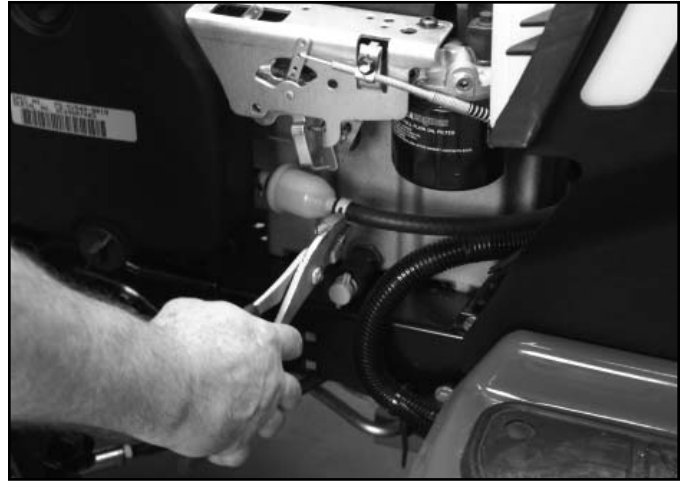

Fig 383

PICT-7094

15. Position the fuel tank support rods and install the screws to secure the fuel tank to the tower (Fig. 382).



Fig 382

PICT-7099a

17. Lower the hood (Fig. 384).



Fig 384

PICT-7063a

18. Start the tractor and run it in both forward and reverse. If additional throttle and choke cable adjustment is required, see steps 7 thru 12 above.

## Engine Replacement

### Removal

1. Remove the mower deck: 42" deck on page 7-64; 46" deck on page 7-69; 50" deck on page 7-74.
2. Disconnect the negative battery cable and then the positive battery cable.
3. Remove the battery hold down strap (Fig. 385).



Fig 385

PICT-7109a

4. Remove the battery from battery compartment (Fig. 386).



Fig 386

PICT-7276

5. Remove the battery tray (Fig. 387).



Fig 387

PICT-7277

6. Raise the machine so the underside of the frame can be accessed.
7. At the front of the tractor, remove the bolt securing the belt keeper rod to the chassis (Fig. 388).

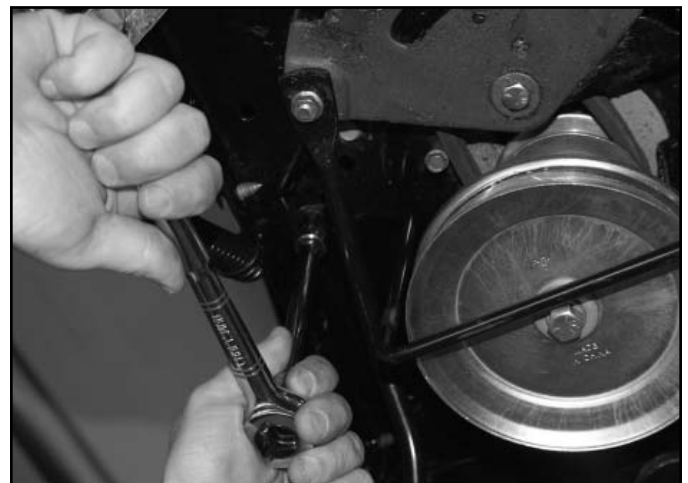

Fig 388

PICT-7347a

# ENGINE

8. Remove the belt keeper rod (Fig. 389).



Fig 389

PICT-7350a

10. While sliding the pulley off the crankshaft, slip the lower transmission drive belt off the pulley (Fig. 391).



Fig 391

PICT-7353

9. Remove the crankshaft bolt and washer (Fig. 390).



Fig 390

PICT-7352

11. Remove the 4 engine mounting bolts (Fig. 392).

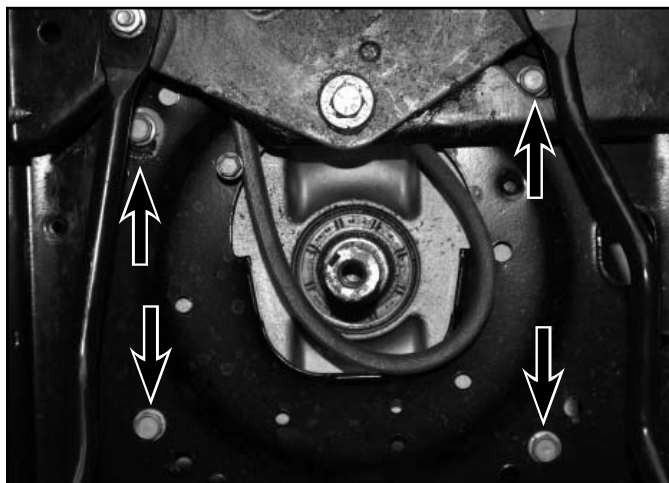

Fig 392

PICT-7355

4

12. Raise the hood (Fig. 393).



Fig 393

PICT-7063

14. Remove the hood (Fig. 395).



Fig 395

PICT-7359

13. Unplug the headlights from the wire harness (Fig. 394).



Fig 394

PICT-7358

15. Remove the oil drain cap and install the drain hose onto the oil drain fitting (Fig. 396).



Fig 396

PICT-7363

# ENGINE

16. Loosen the engine oil dipstick.
17. Twist the oil drain counter-clockwise and drain the oil from the engine (Fig. 397).



Fig 397

PICT-9541

21. If bumper kit is installed: Remove the 2 bolts and nuts securing the front bumper assembly to the support pivot brackets (Fig. 399).



Fig 399

PICT-7367a

18. After oil has drained, turn the oil drain fitting clockwise to close.
19. Remove the drain hose. Reinstall the oil drain fitting cap.
20. Disconnect the fuel line from the fuel filter and drain all the fuel from the fuel tank into an approved container (Fig. 398).

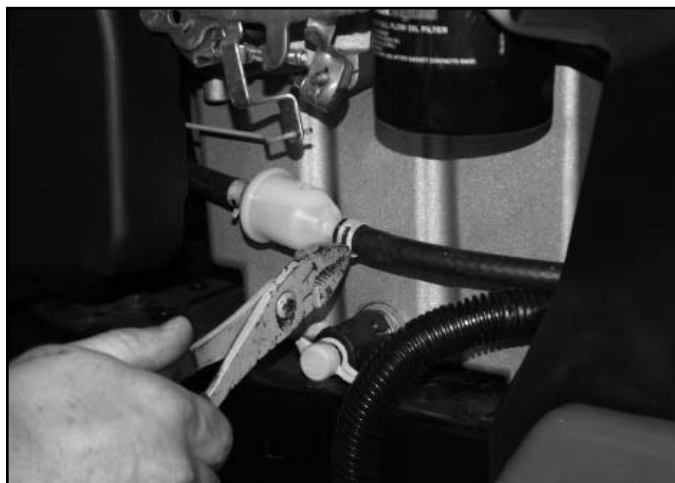

Fig 398

PICT-7365

22. If bumper kit is installed: Remove the bumper (Fig. 400).



Fig 400

PICT-7370

23. Remove the 4 bolts securing the right and left muffler brackets to the frame (2 on the left and 2 on the right) (Fig. 401).



Fig 401

PICT-7371a

24. Remove the muffler and heat shield assembly from the frame (Fig. 402).



Fig 402

PICT-7374

25. Mark the throttle cable at the clamp (Fig. 403).



Fig 403

PICT-7375

26. Loosen the throttle cable clamp and remove the cable from the clamp (Fig. 404).



Fig 404

PICT-7376

# ENGINE

27. Remove the z-bend from the speed control lever (Fig. 405).



Fig 405

PICT-7379

29. Remove the nut securing the positive wire from the starter assembly. Remove the positive wire from the starter assembly (Fig. 407).



Fig 407

PICT-7382

28. Unplug the wire harness (Fig. 406).

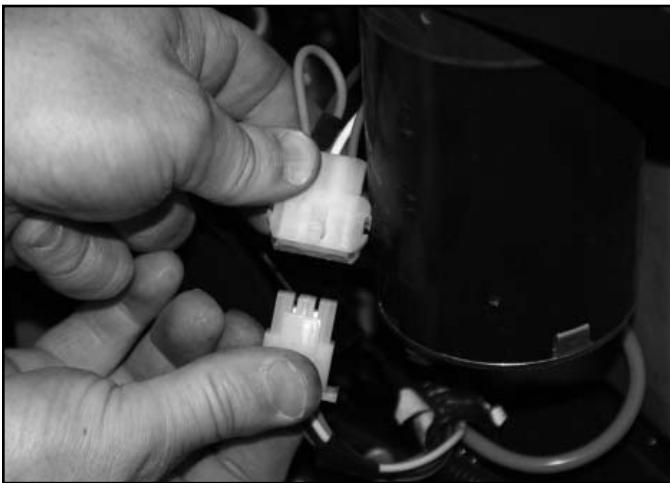

Fig 406

PICT-7380

30. Attach chains/straps and a hoist to the lift points on the engine. Raise and remove the engine from the frame (Fig. 408).



Fig 408

PICT-7386



## Installation

1. Position the engine onto the frame (Fig. 409).



Fig 409

PICT-7386

2. Slide the positive wire onto the starter assembly and install the nut to secure it (Fig. 410).



Fig 410

PICT-7388

3. Unplug the wire harness (Fig. 411).

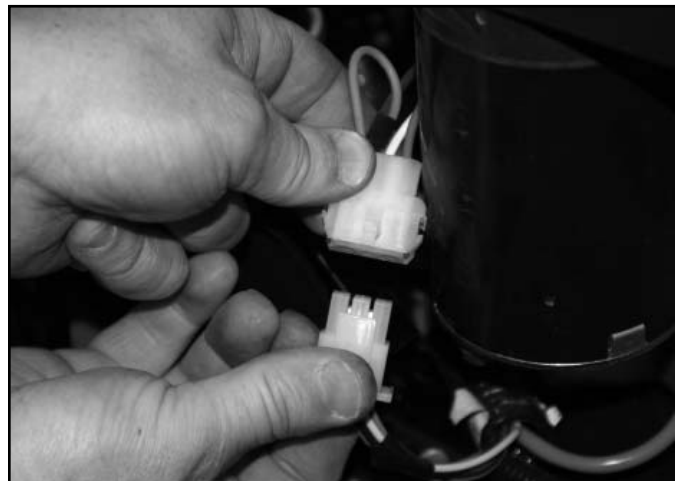

Fig 411

PICT-7380

4. Install the z-bend into the speed control lever (second hole from the top) (Fig. 412).



Fig 412

PICT-7390

4

# ENGINE

5. Install the throttle cable into the cable clamp at the previously marked position (Fig. 413).



Fig 413

PICT-7392

7. Install the hose clamp to secure the fuel line to the filter (Fig. 415).



Fig 415

PICT-7395

6. Connect the fuel line to the fuel filter (Fig. 414).



Fig 414

PICT-7394

8. Position the muffler and heat shield assembly to the frame so that the tail pipe gets inserted into the muffler and the 4 bolt holes line up with the holes in the frame (Fig. 416).

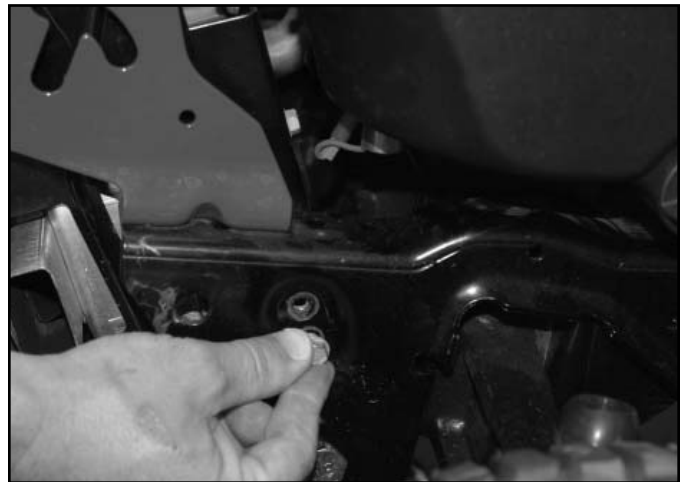

Fig 416

PICT-7396a

4

9. Loosely install the 4 bolts securing the right and left muffler brackets to the frame (2 on the left and 2 on the right). Tighten all 4 bolts. (Fig. 417).



Fig 417

PICT-7371a

11. Optional bumper kit: Install the 2 bolts and nuts securing the front bumper assembly to the support pivot brackets (Fig. 419).



Fig 419

PICT-7367a

10. Optional bumper kit: Position the bumper to the frame (Fig. 418).



Fig 418

PICT-7370

12. Install the hood brackets onto the hood pivot brackets (Fig. 420).



Fig 420

PICT-7359

# ENGINE

13. Plug the headlights into the wire harness (Fig. 421).



Fig 421

PICT-7358

15. Raise the machine so the underside of the frame can be accessed.

16. Align the engine mounting holes with the holes in the frame. Install and tighten the 4 engine mounting bolts (Fig. 423).

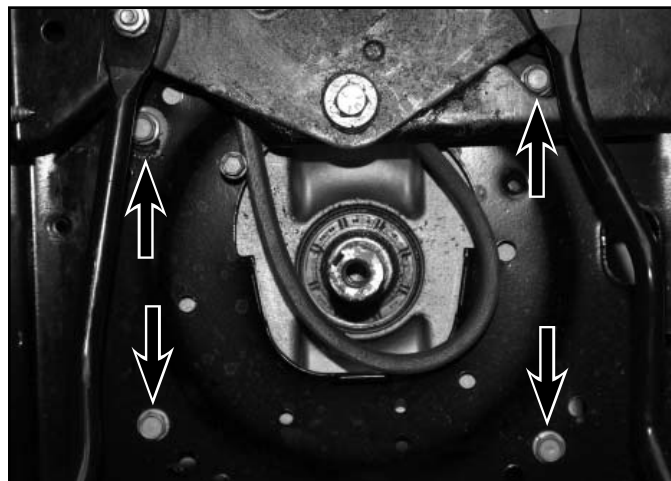

Fig 423

PICT-7355

14. Lower the hood (Fig. 422).



Fig 422

PICT-7063

17. Apply anti-seize compound to the crankshaft (Fig. 424).

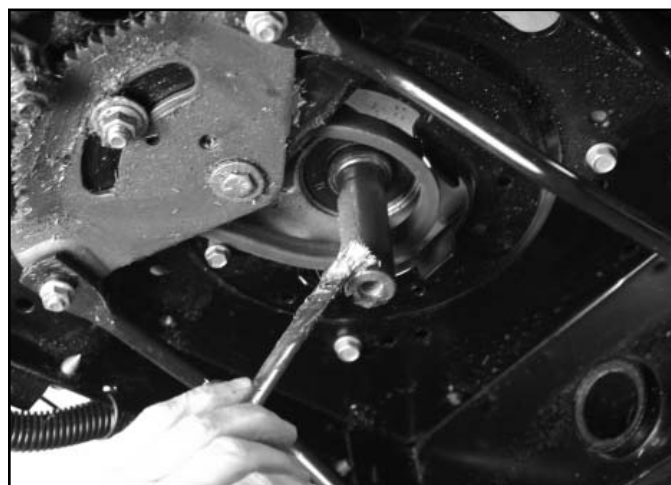

Fig 424

PICT-7315

18. While sliding the engine pulley onto the crankshaft, slip the lower transmission drive belt onto the engine pulley (Fig. 425).



Fig 425

PICT-7317

19. Install the crankshaft bolt and washer securing the pulley to the crankshaft. Torque the bolt to 37.5 to 50 ft-lbs. (50.84 to 67.79 Nm) (Fig. 426).



Fig 426

PICT-7328

20. Ensure the lower transmission drive belt is routed around the double pulley (Fig. 427).

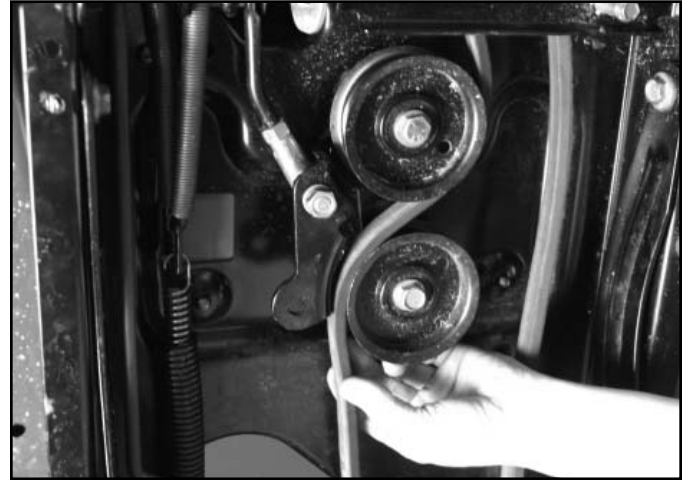

Fig 427

PICT-7332

21. Install the belt keeper rod and secure it to the frame with a bolt (Fig. 428).



Fig 428

PICT-7318

# ENGINE

22. Lower the machine.

23. Install the battery tray (Fig. 429).



Fig 429

PICT-7277

24. Place the battery into the battery compartment (Fig. 430).



Fig 430

PICT-7276

25. Install the battery hold down strap (Fig. 431).



Fig 431

PICT-7497

26. Connect the positive battery cable and then the negative battery cable.

27. Install the mower deck: 42" deck on page 7-67; 46" deck on page 7-72; 50" deck on page 7-76.

28. Fill the engine with oil per the engine specifications.

29. Add fuel to the fuel tank.

30. Check the throttle adjustment. Refer to "Throttle/Choke Cable Replacement - Installation", steps 7 through 12 starting on page 3-97.

# GEAR DRIVE SYSTEM

## CVT Transmission Replacement

### Removal

1. Remove the negative battery cable (Fig. 432).



Fig 432

PICT-7107

2. Using a hoist or hydraulic floor jack, raise the rear of the tractor off the ground (Fig. 433).



Fig 433

PICT-7219

3. Remove both rear hub caps from the rear wheel assemblies (Fig. 434).



Fig 434

PICT-7220

4. Loosen and remove the bolt, washer, and hub cap washer located on the right and left rear tire assemblies (Fig. 435).



Fig 435

PICT-7221

5

# GEAR DRIVE SYSTEM

5. Remove the right and left rear tires (Fig. 436).



Fig 436

PICT-7222

7. Slide the shift linkage forward away from the transmission (Fig. 438).



Fig 438

PICT-7229a

6. Shift the forward/reverse lever to the forward position. This will allow enough clearance to remove the hairpin cotter. Remove the hairpin cotter that secures the shift linkage to the shift fork (Fig. 437).

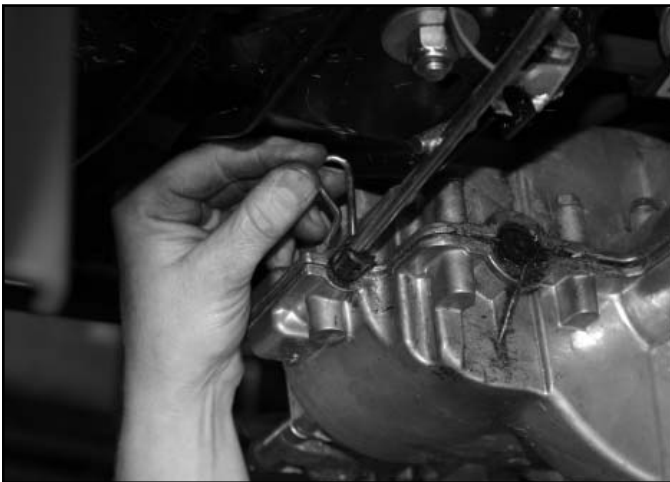

Fig 437

PICT-7224

8. Support the bottom of the transmission with jack supports or a hydraulic floor jack (Fig. 439).



Fig 439

PICT-7230

5



# GEAR DRIVE SYSTEM

9. Remove the self tapping screws and washers that secure the transmission to the front torque bracket (Fig. 440).

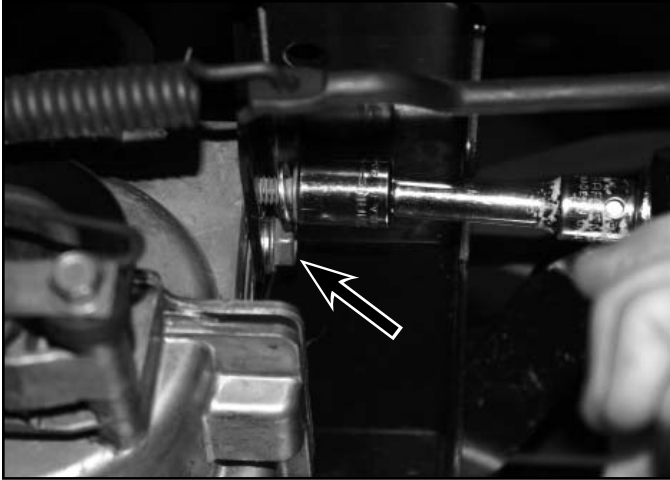

Fig 440

PICT-7233

11. Remove the transmission mounting bracket (Fig. 442).



Fig 442

PICT-7237

10. Remove the two hex bolts and lock nuts securing the right hand side of the transmission to the frame (Fig. 441).

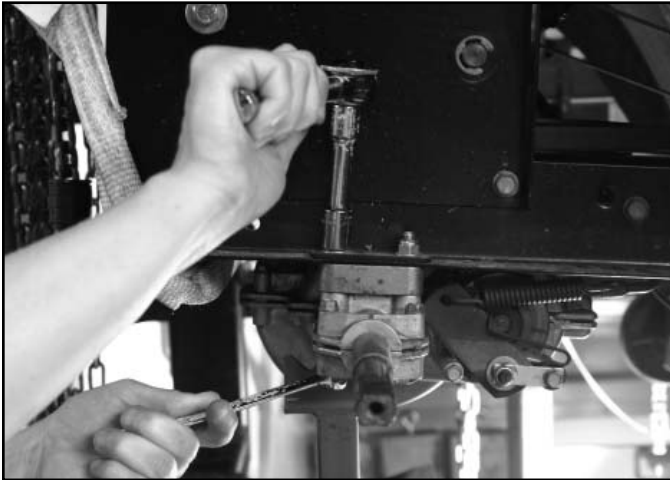

Fig 441

PICT-7236

12. Remove the two hex bolts and lock nuts securing the left hand side of the transmission to the frame.

**Note:** The rear hex bolt and lock nut are installed opposite of the other three bolts retaining the transmission to the frame (Fig. 443).

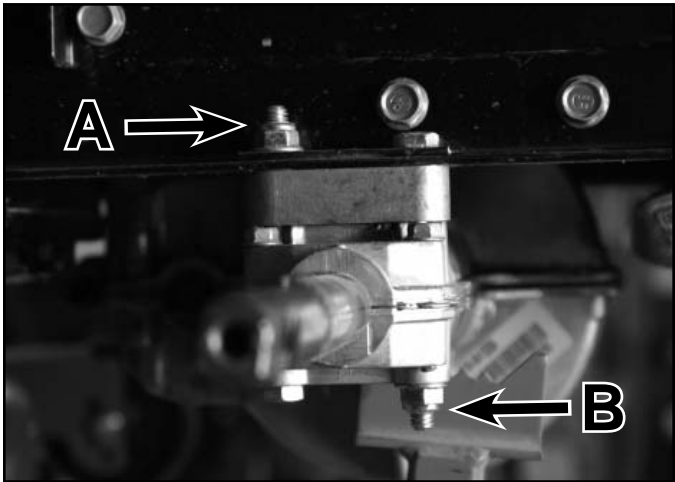

Fig 443

PICT-7238

- A. Front bolt, installed up
- B. Rear bolt, installed down

# GEAR DRIVE SYSTEM

13. Remove the two bolts and the spacer located on the right side of the transmission (Fig. 444).



Fig 444

PICT-7240

15. While lowering the transmission out of the frame, remove the transmission belt (Fig. 446).

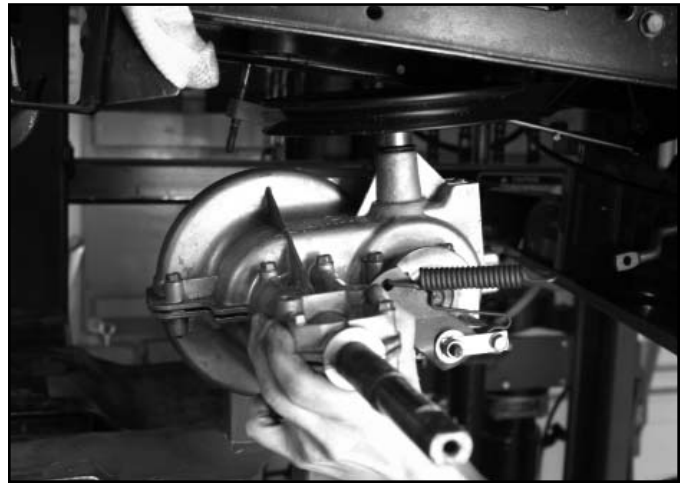

Fig 446

PICT-7243

14. Remove the brake spring from the brake rod (Fig. 445).



Fig 445

PICT-7242

## Installation

1. Position the transmission to the frame (Fig. 447).

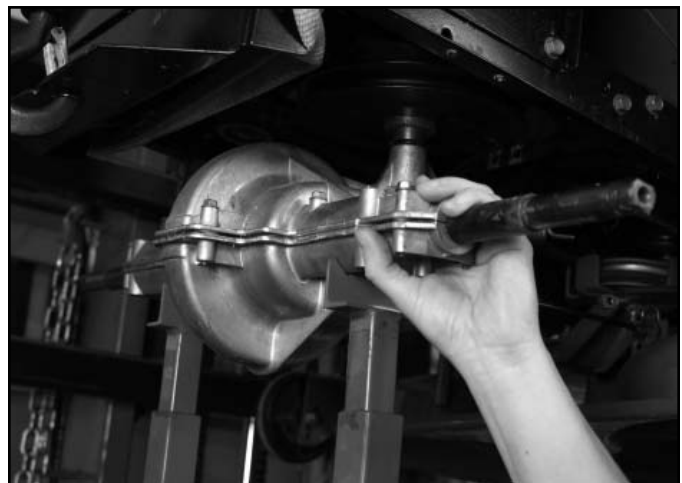

Fig 447

PICT-7248

5

# GEAR DRIVE SYSTEM

- 2. With the spacer installed, line the left side rear bolt hole in the transmission with the rear left bolt installed downward from the chassis (Fig. 448).

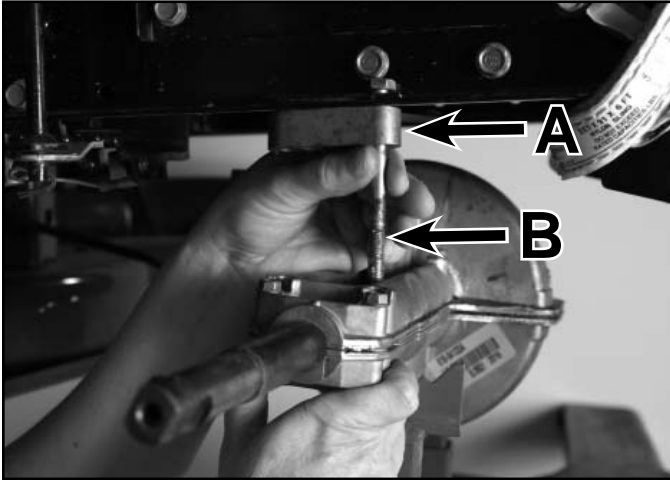

Fig 448 PICT-7251

- A. Spacer
- B. Bolt

- 3. Loosely install the nut onto the bolt (Fig. 449).

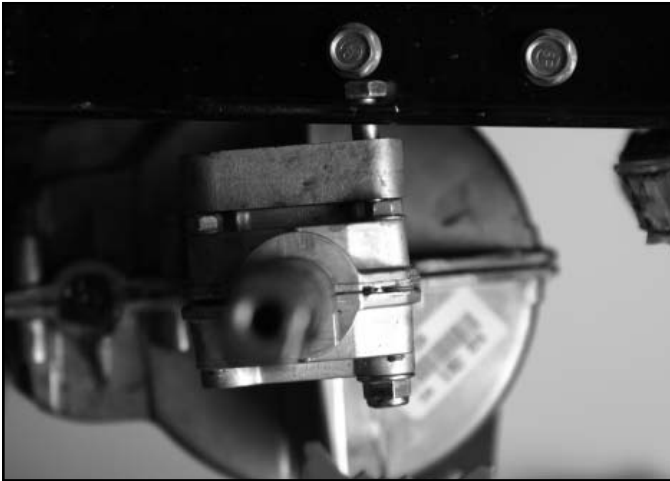

Fig 449 PICT-7253

- 4. Install the transmission belt onto the transmission pulley (Fig. 450).



Fig 450 PICT-7254

- 5. Position the second spacer on the right side of the transmission and install a bolt (upward). Insert the bolt up through the frame and loosely install the nut (Fig. 451).

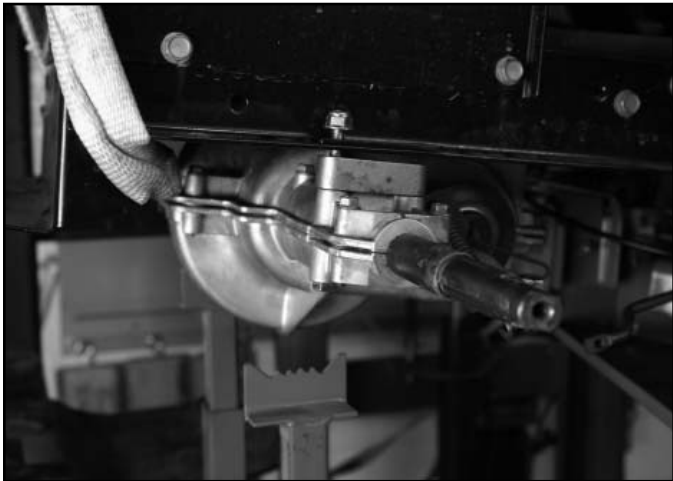

Fig 451 PICT-7255

5

# GEAR DRIVE SYSTEM

- Loosely install the 2 bolts and washers securing the transmission to the front torque bracket (Fig. 452).

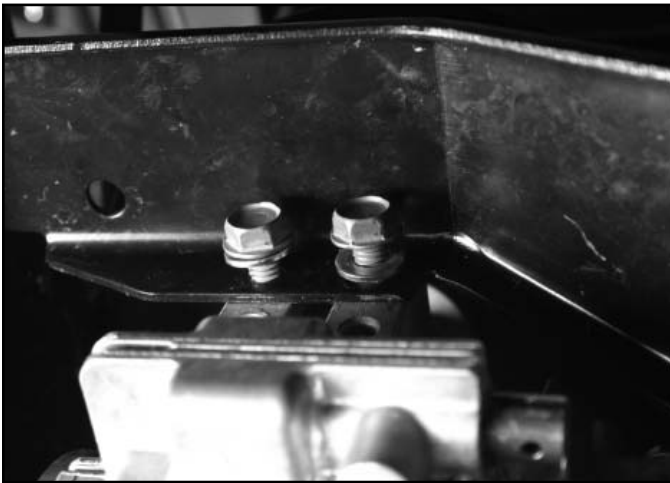

Fig 452

PICT-7256

- Install the remaining bolt up through the transmission, spacer and chassis on the left side of the transmission. Loosely install the nut (Fig. 454).

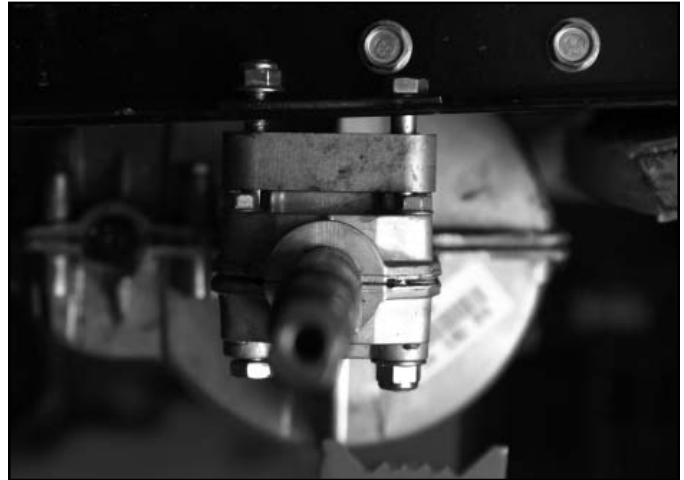

Fig 454

PICT-7261

- Install the second bolt up through the transmission, spacer and frame on the right side of the transmission. Loosely install the nut (Fig. 453).

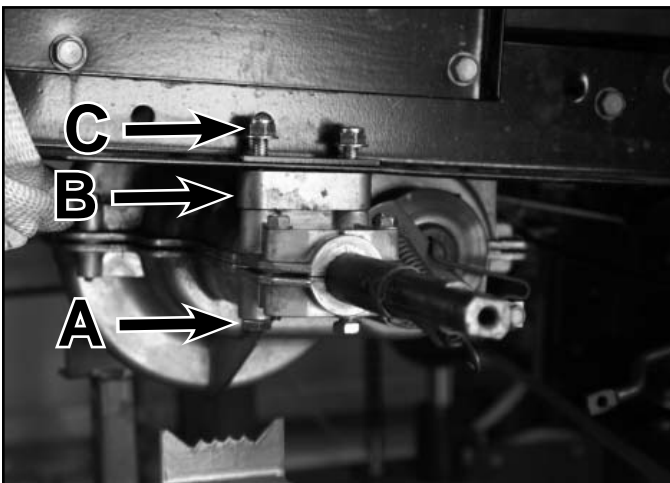

Fig 453

PICT-7257

- A. Bolt head
- B. Spacer

- C. Nut

- Using a spring removal tool (Toro p/n: 92-5771), install the brake spring to the brake rod (Fig. 455).

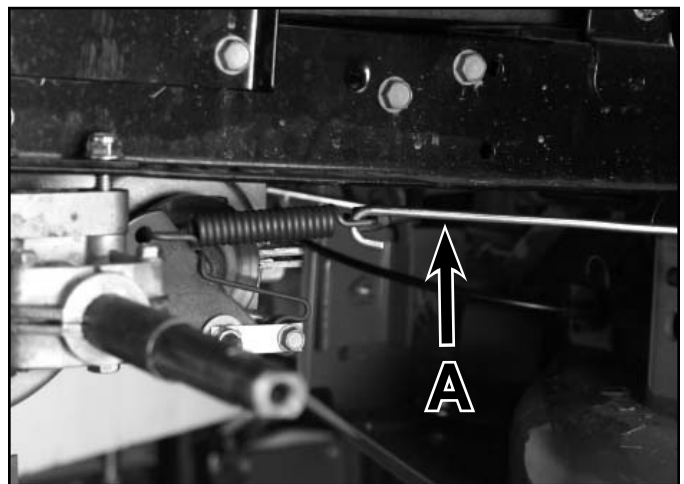

Fig 455

PICT-7266

- A. Spring removal tool

# GEAR DRIVE SYSTEM

10. Tighten the six bolts securing the transmission to the frame.
11. Ensure the shift fork is pushed into the transmission all the way (forward position). Position the shift rod into the shift fork and install a hairpin to secure (Fig. 456).



Fig 456

PICT-7268

13. Move the shifter to neutral (Fig. 458).

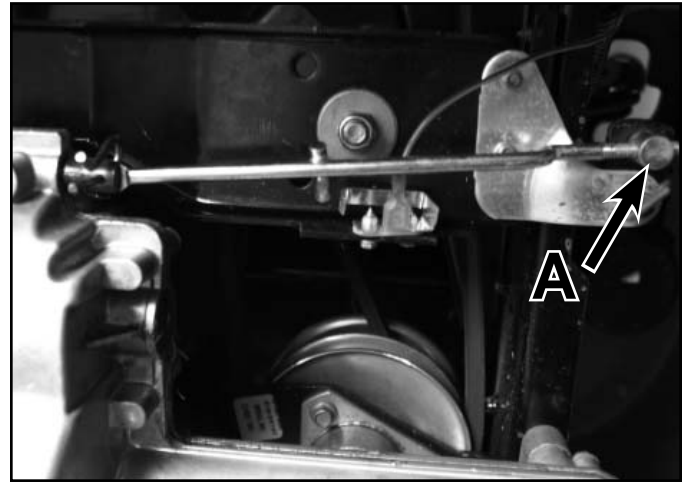

Fig 458

PICT-7271

- A. Shift rod adjustment trunnion

12. Shift rod alignment check: The shift fork in the forward position (Fig. 457).

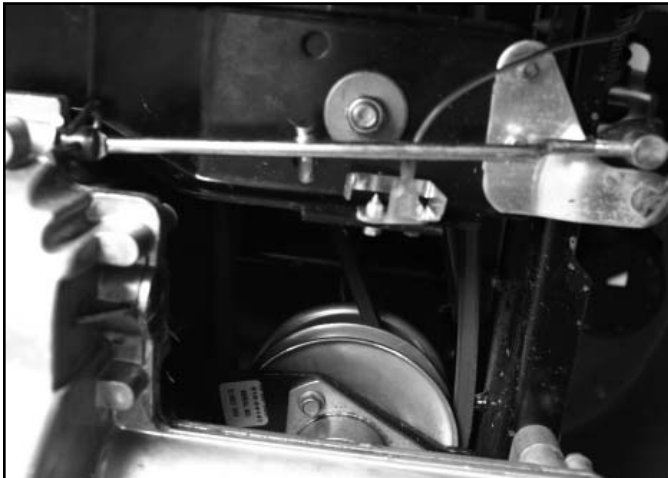

Fig 457

PICT-7270

14. Move the shifter to reverse (Fig. 459).



Fig 459

PICT-7274

# GEAR DRIVE SYSTEM

15. In the reverse position, the spring switch tab should be fully depressed. If adjustment is needed, move the shifter to the neutral position. Remove the hair-pin from the shift rod trunnion. Rotate the trunnion clockwise or counterclockwise until the shift rod connects with the reverse spring switch when the shift lever is in the reverse position (Fig. 460 and Fig. 461).

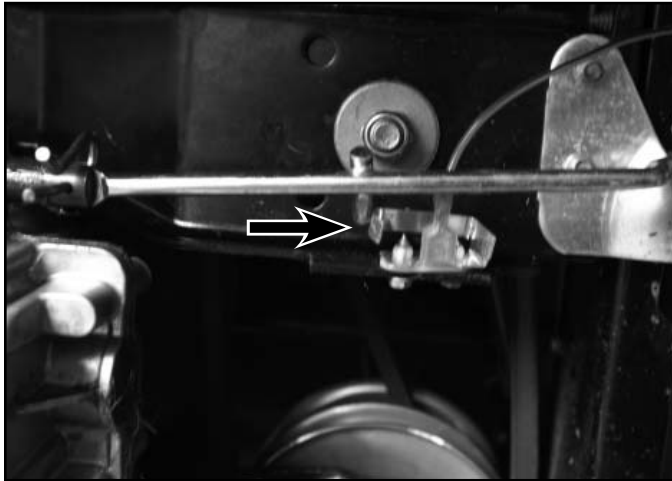

Fig 460

PICT-7274

16. Apply anti-sieze compound to the axles. Slide the left and right wheel assemblies onto tthe axles (Fig. 462).



Fig 462

PICT-7222

17. Install the hub cap washer, washer and bolt securing the rear right wheel assembly to the axle. Repeat for rear left wheel assembly (Fig. 463).



Fig 463

PICT-7221

A. Shift rod adjustment trunnion

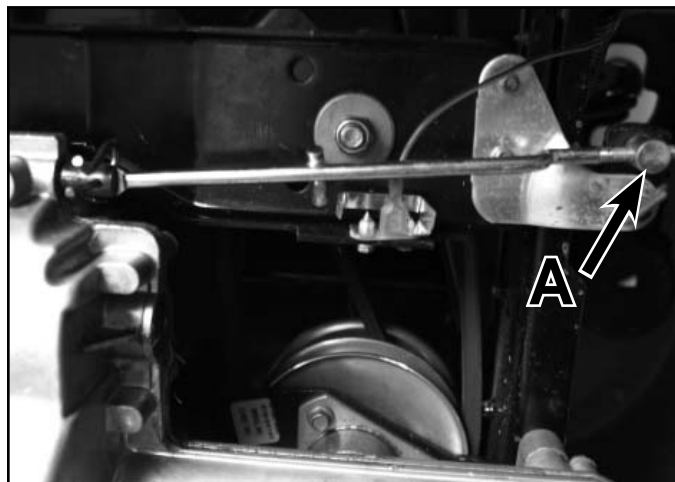

Fig 461

PICT-7271

# GEAR DRIVE SYSTEM

18. Install both rear hub caps (Fig. 464).



Fig 464

PICT-7220

20. Install the negative battery cable (Fig. 466).



Fig 466

PICT-7107

19. Lower the tractor and remove it from the hoist/floor jack (Fig. 465).



Fig 465

PICT-7219

21. Test operate tractor in forward and reverse. Ensure the reverse caution mode system is functioning properly.

5

## Brake Puck Replacement

### Removal

1. Remove the hub cap from the right rear wheel (Fig. 467).



Fig 467

PICT-9608

# GEAR DRIVE SYSTEM

2. Loosen the bolt retaining the right rear wheel to the axle (Fig. 468).



Fig 468

PICT-9609

5. Remove the 2 hex head screws retaining the brake assembly to the gear drive transmission (Fig. 470).

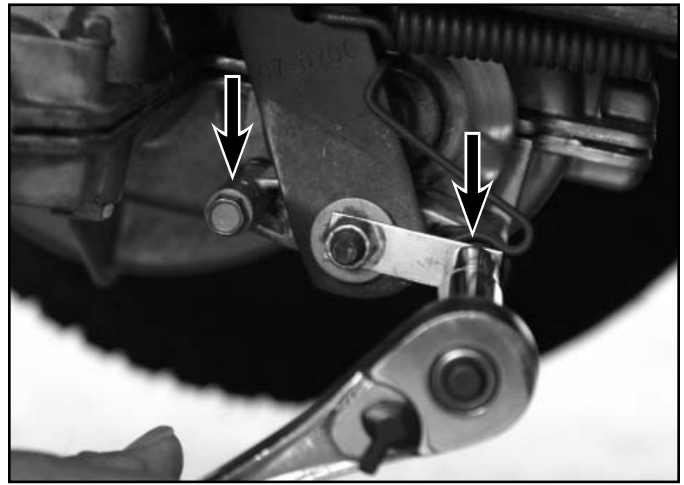

Fig 470

PICT-9656

3. Raise and support the right rear of the tractor, allowing enough clearance to remove the right rear tire.
4. Remove the bolt, washer and wheel assembly from the right axle (Fig. 469).



Fig 469

PICT-9655

6. Unhook the spring from the brake rod and brake assembly (Fig. 471).



Fig 471

PICT-9618

5



# GEAR DRIVE SYSTEM

7. Remove the outer puck from the brake assembly (Fig. 472).



Fig 472

PICT-9620

9. Remove the inner puck (Fig. 474).



Fig 474

PICT-9622

8. Remove the brake disc (Fig. 473).

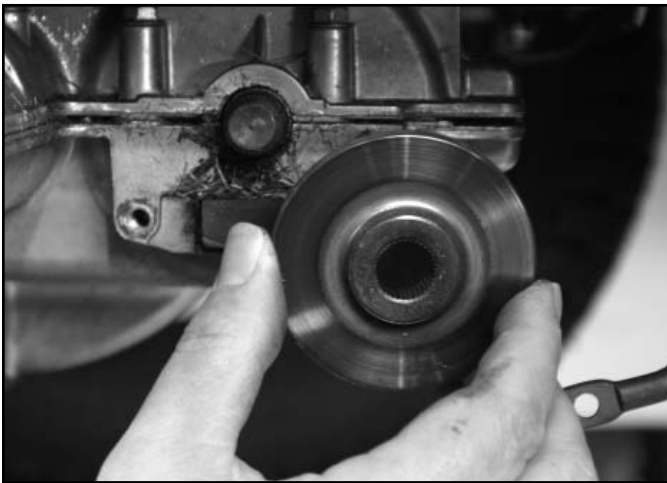

Fig 473

PICT-9621

## Installation

1. Install a new inner brake puck (Fig. 475).



Fig 475

PICT-9623

5

# GEAR DRIVE SYSTEM

2. Install the brake disc onto the brake shaft (Fig. 476).

**Note:** A new brake disc should be used if the original is deeply grooved, worn or overheated.



Fig 476

PICT-9657

4. Hook the spring from the brake assembly to the brake rod (Fig. 478).



Fig 478

PICT-9618

**5**

3. Install a new outer puck onto the brake assembly (Fig. 477).



Fig 477

PICT-9620

5. Position the brake assembly to the transmission and install 2 hex head screws to secure it (Fig. 479).



Fig 479

PICT-9615

# GEAR DRIVE SYSTEM

6. Insert a .011" (.28mm) feeler gauge in between the outer puck and the disc. Tighten or loosen the adjusting hex nut until the proper gap is achieved (Fig. 480).



Fig 480

PICT-9660

7. Slide the wheel onto the axle (Fig. 481).



Fig 481

PICT-9611

8. Install the washer and bolt securing the wheel to the axle (Fig. 482).



Fig 482

PICT-9609

9. Lower the machine so all tires are on the ground.

10. Install the hub cap (Fig. 483).



Fig 483

PICT-9608

11. Check the brake operation. Refer to "Brake Adjustment – Gear Drive" following.

# GEAR DRIVE SYSTEM

## Brake Adjustment

1. Park the machine on a level surface and disengage the blade control (PTO). Set the parking brake, and turn the ignition key to Off to stop the engine.
2. If the rear wheels lock and skid when you push the tractor forward, no adjustment is required. An adjustment is required if the wheels turn and do not lock.
3. Release the parking brake.
4. To adjust the brake, loosen the brake adjusting nut slightly (Fig. 484).



Fig 484

PICT-9633

5. Insert a .011" (.28mm) feeler gauge between the disc and the outer puck. If the clearance is not correct make the necessary adjustment with the brake adjusting nut. Tighten the brake adjusting nut until slight resistance is felt on the feeler gauge when sliding it in and out (Fig. 485).



Fig 485

PICT-9626

6. Check the brake operation again. See steps 1 and 2.

**Important:** With the parking brake released the rear wheels must rotate freely when you push the unit. If they do not rotate freely, additional brake adjustment must be made.

# HYDROSTATIC DRIVE SYSTEM

## Hydro Transmission Replacement

### Removal

1. Remove the mower deck. Refer to "46" Mower Deck Removal" on page 7-69.
2. Disconnect the negative battery cable (Fig. 486).

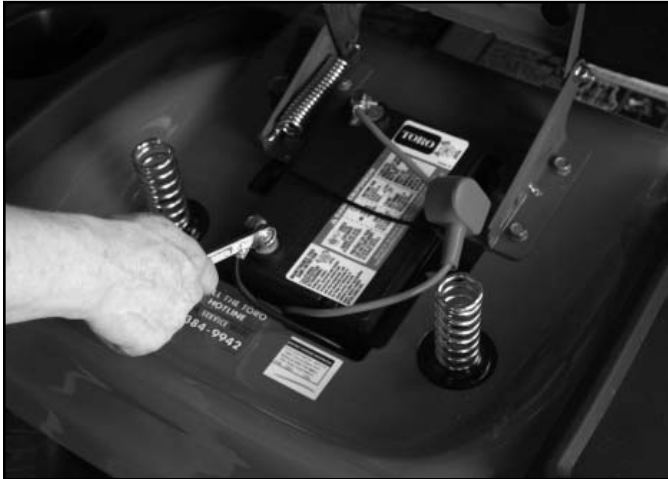

Fig 486

PICT-7494

3. Disconnect the positive battery cable (Fig. 487).



Fig 487

PICT-7495

4. Remove the battery hold down strap (Fig. 488).



Fig 488

PICT-7497

5. Lift the battery out of the battery tray (Fig. 489).



Fig 489

PICT-7499

# HYDROSTATIC DRIVE SYSTEM

6. Remove the battery tray (Fig. 490).



Fig 490

PICT-7500

8. Remove the transmission drive belt from the fixed V idler (Fig. 492).



Fig 492

PICT-7508

7. With a spring removal tool, remove tension from the center double idler bracket and remove the transmission drive belt from the idler (Fig. 491).



Fig 491

PICT-7505

9. Secure the engine pulley and remove the bolt and washer retaining it to the crankshaft (Fig. 493).

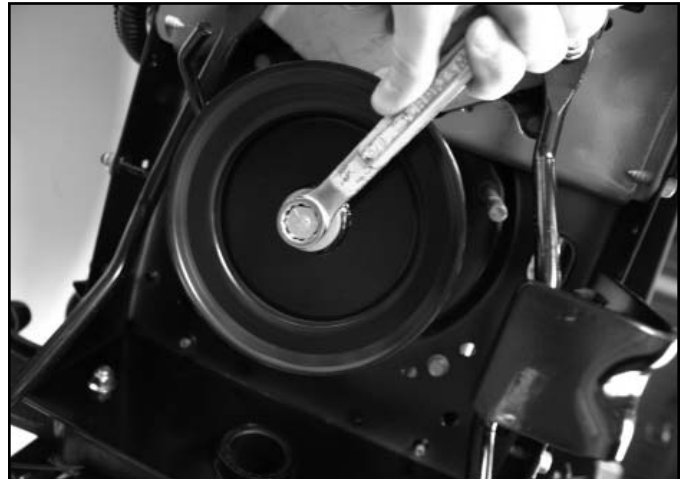

Fig 493

PICT-7507

6

# HYDROSTATIC DRIVE SYSTEM

- Slide the engine pulley off the crankshaft. As the pulley is being slid off the crankshaft, remove the transmission drive belt from the pulley (Fig. 494).



Fig 494

PICT-7510

- Route the transmission drive belt out from above the steering support bracket (Fig. 496).

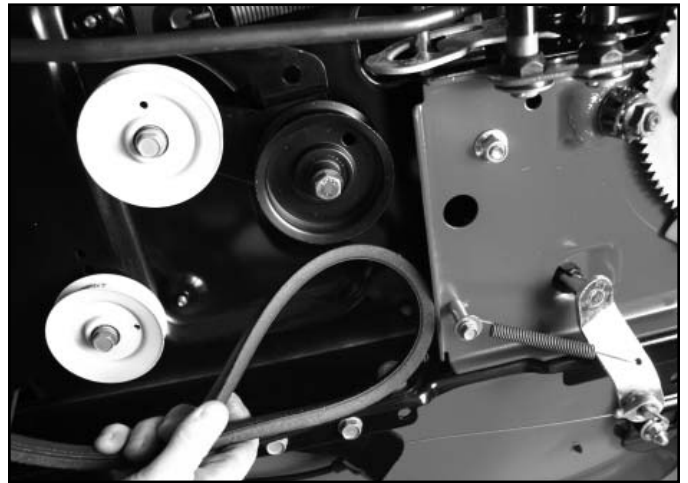

Fig 496

PICT-7515

- Remove the transmission drive belt from around the crankshaft (Fig. 495).



Fig 495

PICT-7514

- Remove the transmission drive belt from around the transmission pulley and fan (Fig. 497).



Fig 497

PICT-7518

# HYDROSTATIC DRIVE SYSTEM

14. Insert a spring removal tool through the opening in the rear of the machine (Fig. 498).



Fig 498

PICT-7553

16. Loosen the bolts securing the rear tires to the axle (Fig. 500).



Fig 500

PICT-7519

15. Using the spring removal tool, unhook the hydro linkage return spring from the stud (Fig. 499).

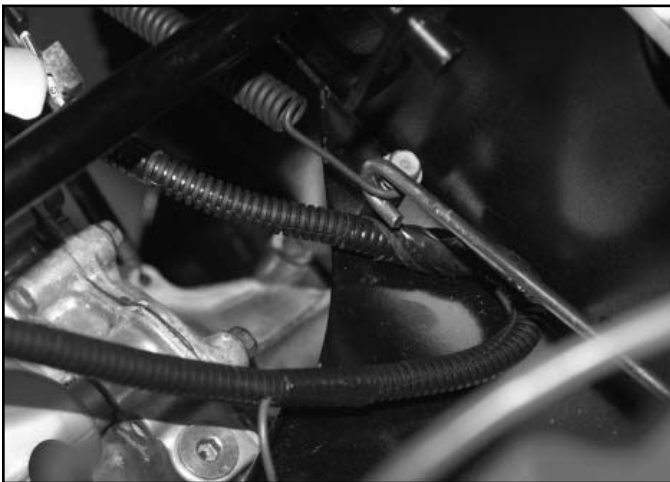

Fig 499

PICT-7555a

17. Raise and support the machine so the rear tires are off the ground.

18. Remove the bolt and washer retaining the rear tire to the axle (Fig. 501).



Fig 501

PICT-7519

6



# HYDROSTATIC DRIVE SYSTEM

19. Remove the wheel and tire assembly from the axle (Fig. 502).



Fig 502

PICT-7521

22. Disconnect the short spring switch wire terminal from the switch post (Fig. 504).



Fig 504

PICT-7556

20. Repeat steps 18 and 19 to remove the other rear tire.

21. Remove the bypass rod spring from the bypass lever. Move the rod out of the way (Fig. 503).



Fig 503

PICT-7578

23. Remove the self tapping screw securing the ground wire (green) to the linkage bracket (Fig. 505).



Fig 505

PICT-7543a

# HYDROSTATIC DRIVE SYSTEM

24. Remove the brake lever return spring from the transmission housing (Fig. 506).

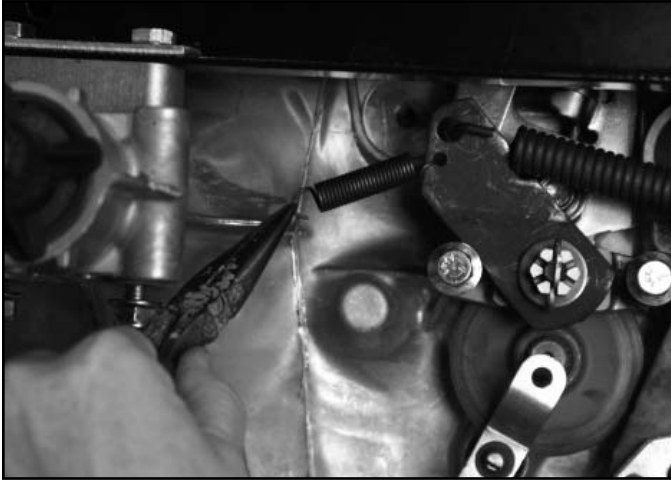

Fig 506

PICT-7557

26. Remove the hairpin cotter from the trunnion on the front end of the control rod and remove the trunnion from the control pedal assembly (Fig. 508).



Fig 508

PICT-7533a

25. Remove the cotter pin from the front end of the brake lever rod and remove the brake lever rod from the brake lever (Fig. 507).

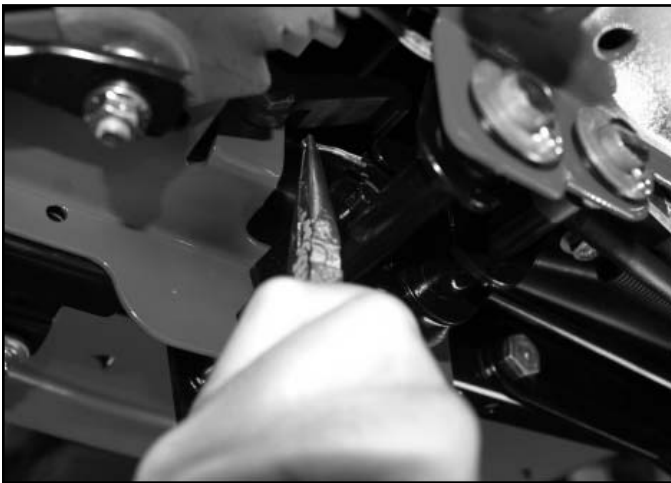

Fig 507

PICT-7529

27. Support the hydro transmission.

28. Remove the 4 screws securing the front transmission support to the frame (2 screws on each side) (Fig. 509).

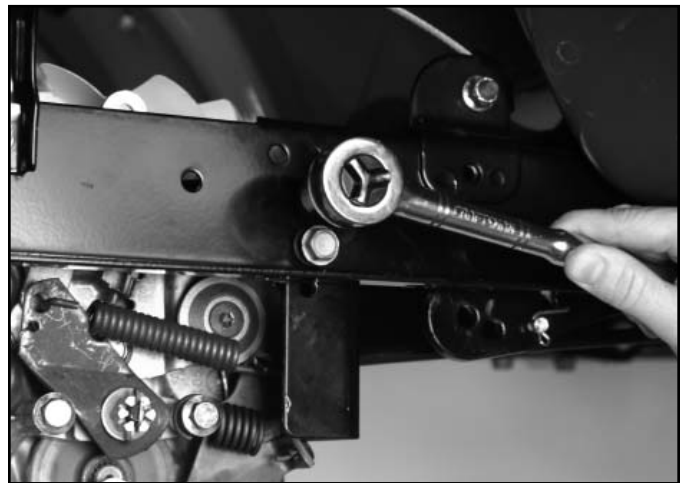

Fig 509

PICT-7558

6

# HYDROSTATIC DRIVE SYSTEM

29. Remove 4 nuts from the 4 bolts securing the transmission to the frame (Fig. 510).

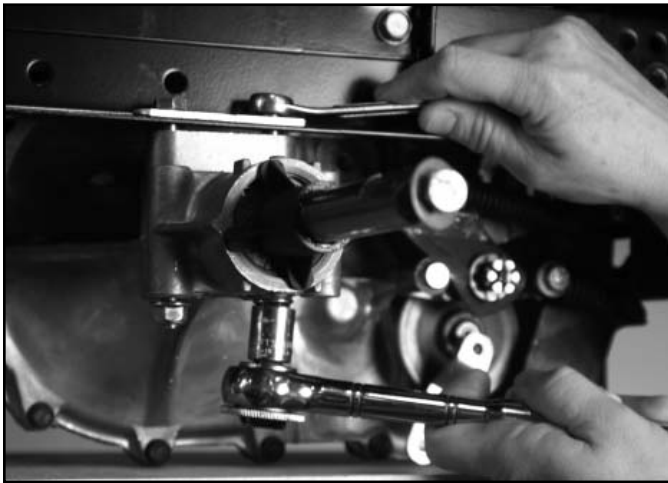

Fig 510

PICT-7560

30. Remove the 4 bolts, mounting bolts and spacers and carefully lower the transmission. Remove it from the frame (Fig. 511).

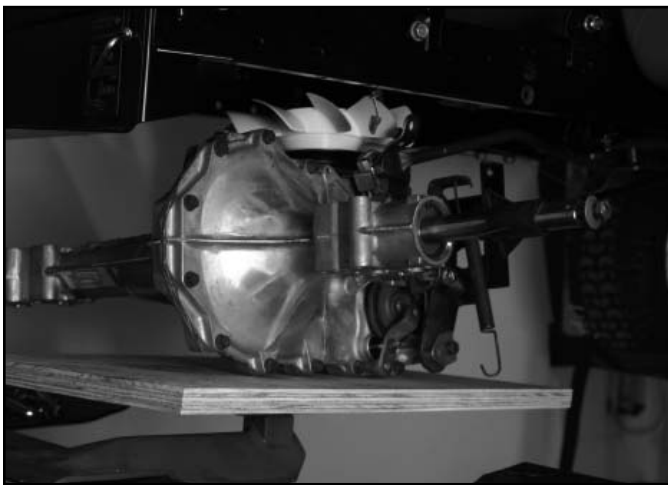

Fig 511

PICT-7563

## Installation

1. As required, install parts on the transaxle to place it in "as removed" condition. Raise the hydro transmission into position (Fig. 512).

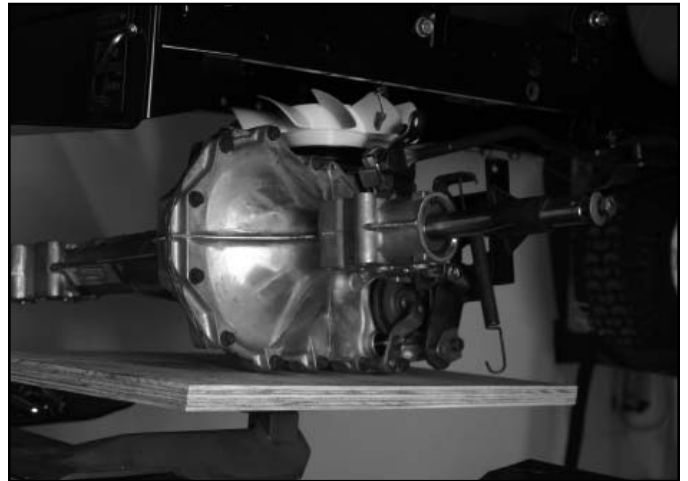

Fig 512

PICT-7563

2. Loosely install 4 self tapping bolts (2 on each side) to secure the transmission support bracket to the frame (Fig. 513).

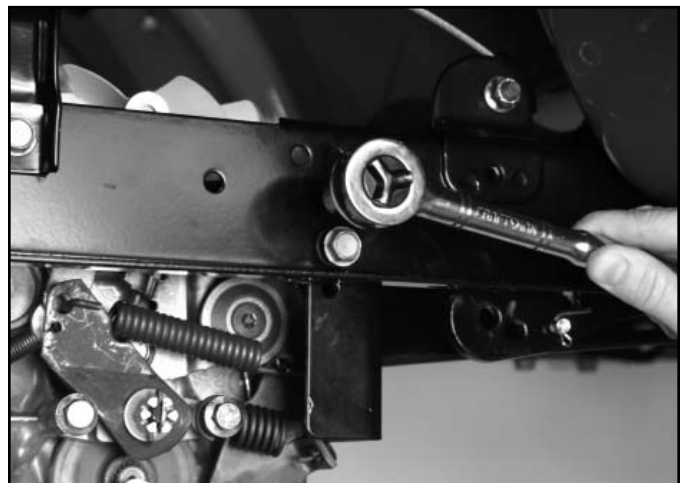

Fig 513

PICT-7558

6

# HYDROSTATIC DRIVE SYSTEM

**Note:** Line up the top two holes in the bracket with the bottom two holes in the frame (Fig. 514).



Fig 514

PICT-7572

4. Position a transaxle spacer between the frame and the axle housing, lining it up with the middle set of holes on the axle housing. Repeat on opposite side (Fig. 516).



Fig 516

PICT-7575

3. Place a transmission mounting bracket on top of the frame, lining it up with the transmission mounting holes (Fig. 515).

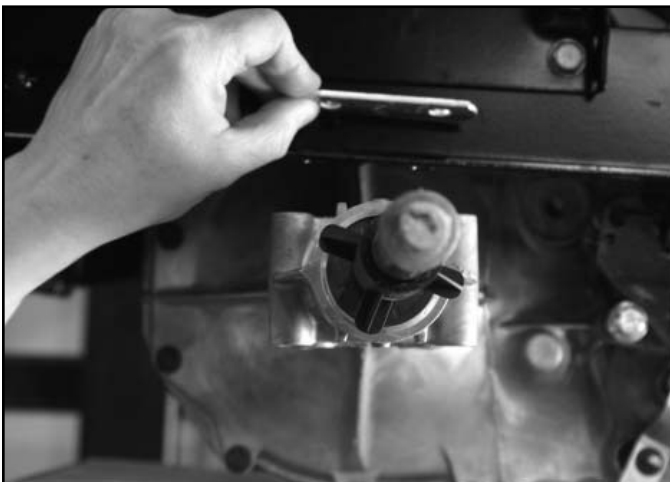

Fig 515

PICT-7574

5. Insert the 4 mounting bolts (2 on each side) down through the mounting bracket, frame, spacer and axle housing holes (Fig. 517).

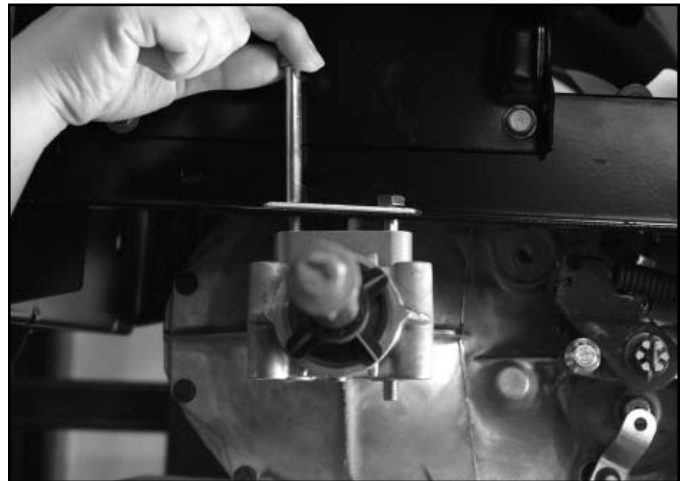

Fig 517

PICT-7576

6

# HYDROSTATIC DRIVE SYSTEM

- Loosely install a nut onto each of the 4 mounting bolts (Fig. 518).

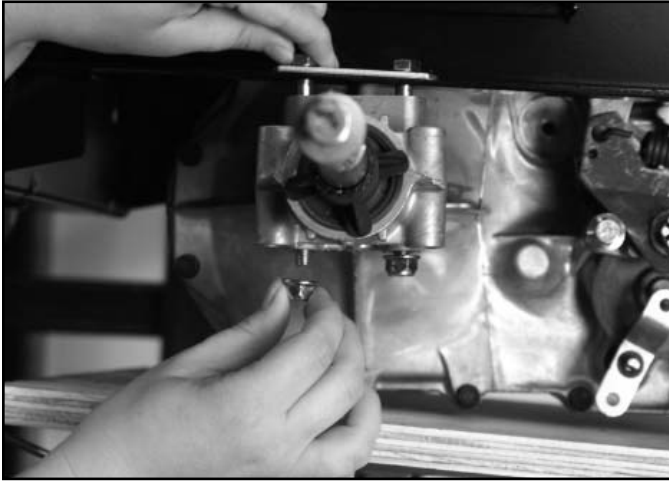

Fig 518

PICT-7577

- Insert the control rod trunnion into the control pedal assembly and install a hairpin cotter to secure (Fig. 520).

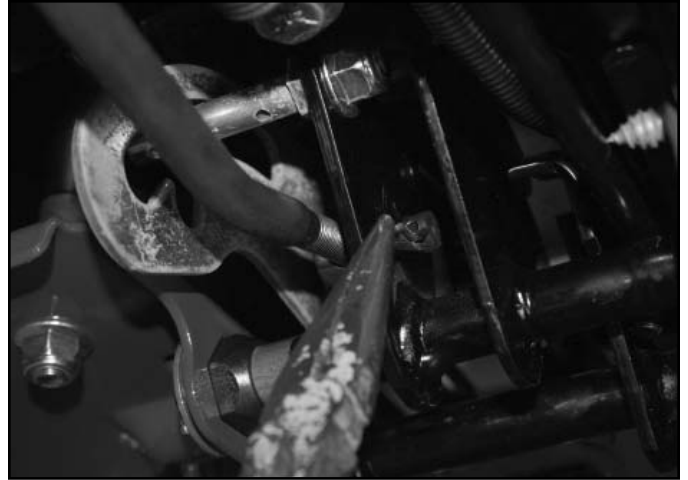

Fig 520

PICT-7533a

- Tighten all 8 mounting bolts: 4 self tapping screws securing the transmission mounting bracket to the frame and 4 bolts and nuts securing the axle housing to the frame.
- Insert the brake lever linkage rod into the brake lever and install a cotter pin to secure (Fig. 519).



Fig 519

PICT-7529

- Attach the brake lever return spring to the axle housing (Fig. 521).

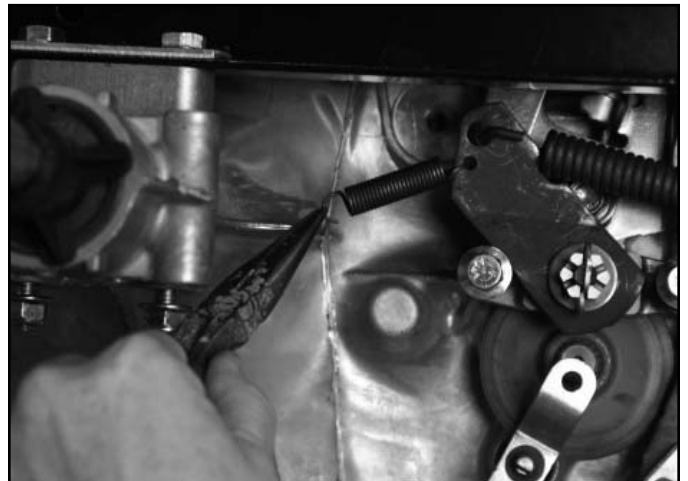

Fig 521

PICT-7557

# HYDROSTATIC DRIVE SYSTEM

11. Position the ground wire (green) and install the self tapping screw securing the ground wire to the linkage bracket (Fig. 522).



Fig 522

PICT-7543a

13. Position the bypass rod and attach the bypass rod spring to the transmission bypass lever (Fig. 524).

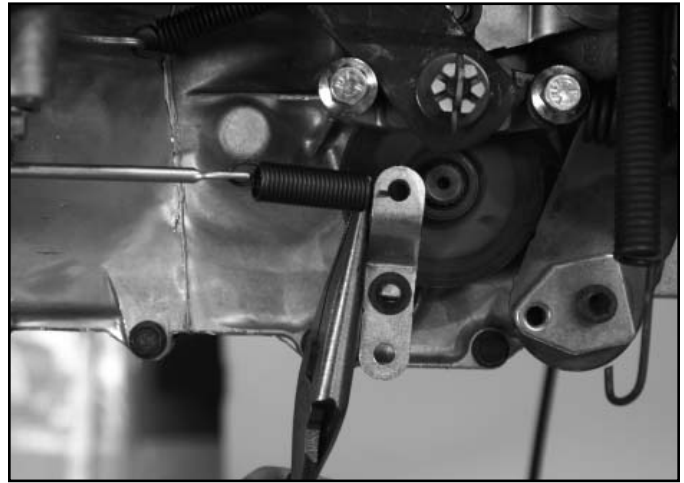

Fig 524

PICT-7578

12. Connect the short spring switch wire terminal to the switch post (Fig. 523).



Fig 523

PICT-7556

14. Slide the wheels onto the axles (Fig. 525).



Fig 525

PICT-7521

6

# HYDROSTATIC DRIVE SYSTEM

15. Install the 2 bolts and washers to secure the wheels to the axles (Fig. 526).



Fig 526

PICT-7519

17. Using the spring removal tool, hook the hydro linkage return spring to the stud (Fig. 528).

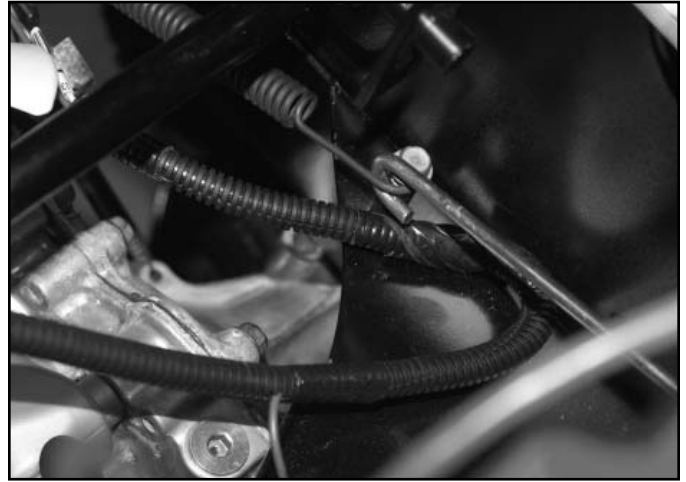

Fig 528

PICT-7555a

16. Insert a spring removal tool through the opening in the rear of the machine (Fig. 527).



Fig 527

PICT-7553

18. Route the transmission drive belt around the transmission fan and pulley (Fig. 529).



Fig 529

PICT-7518

# HYDROSTATIC DRIVE SYSTEM

19. Route the transmission drive belt between the steering support bracket and frame (Fig. 530).

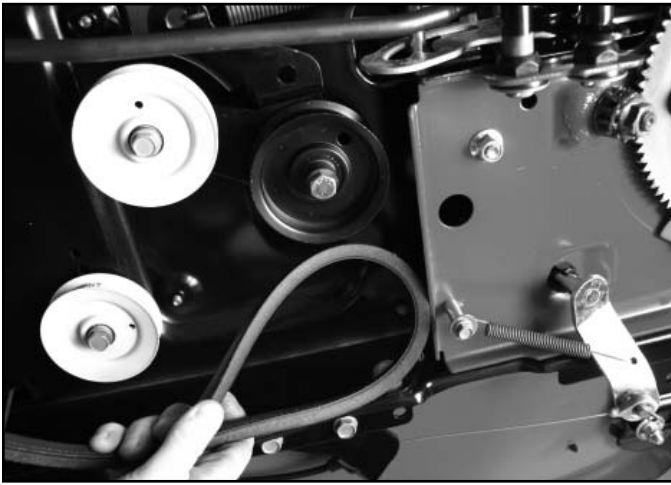

Fig 530

PICT-7515

21. Slide the engine pulley onto the crankshaft and install the transmission drive belt around the upper pulley (Fig. 532).

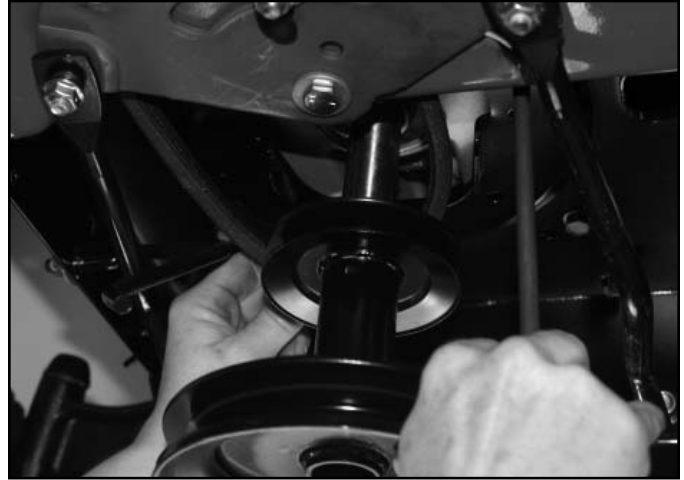

Fig 532

PICT-7510

20. Position the transmission drive belt around the crankshaft (Fig. 531).



Fig 531

PICT-7514

22. Install the crankshaft bolt and washer securing the pulley to the crankshaft. Torque the bolt to 37.5 to 50 ft-lbs. (50.84 to 67.79 Nm) (Fig. 533).

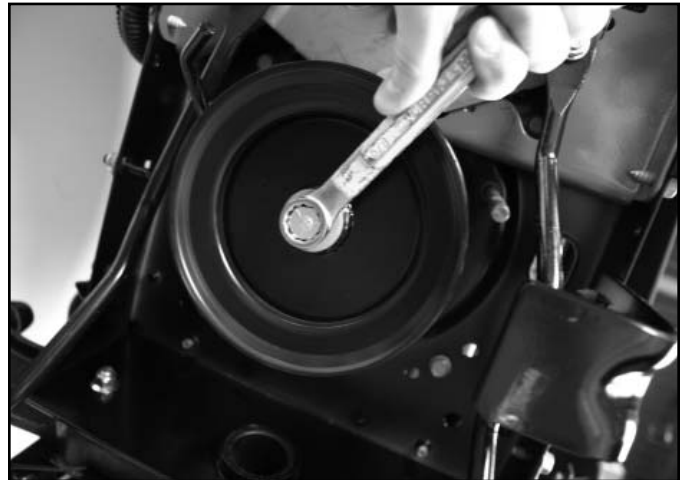

Fig 533

PICT-7507

6



# HYDROSTATIC DRIVE SYSTEM

23. Route the transmission drive belt around the fixed V idler (Fig. 534).



Fig 534

PICT-7508

25. Install the battery tray (Fig. 536).

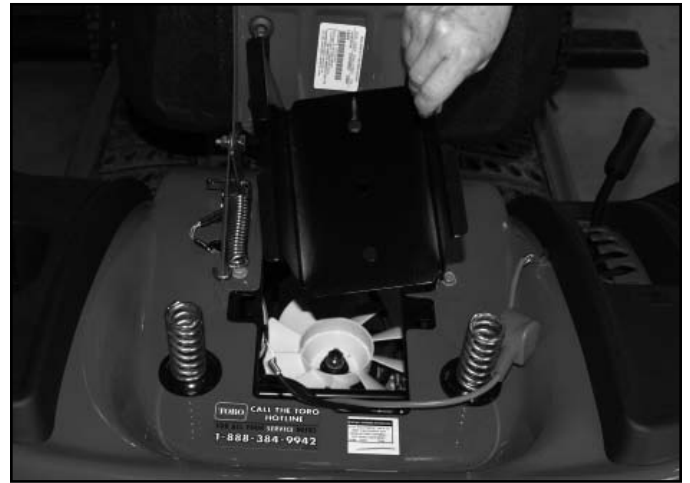

Fig 536

PICT-7500

24. Using a spring removal tool, remove tension from the center double idler bracket and route the transmission drive belt around the idler (Fig. 535).



Fig 535

PICT-7505

26. Install the battery into the battery tray (Fig. 537).



Fig 537

PICT-7499

# HYDROSTATIC DRIVE SYSTEM

27. Install the battery hold down strap (Fig. 538).



Fig 538

PICT-7497

29. Install the negative battery cable (Fig. 540).



Fig 540

PICT-7494

28. Install the positive battery cable (Fig. 539).



Fig 539

PICT-7495

30. Test operate tractor to confirm proper operation. Adjust the brake, refer to "Brake Adjustment" on page 3-91, and make neutral adjustment if needed, refer to "Neutral Adjustment" on page 3-84.

31. Install the mower deck. Refer to "46" Mower Deck Installation" on page 7-72.

32. Test operate tractor.

6

## 42" Mower Deck - Brake Idler Assembly Replacement

### Removal

1. Remove the mower deck. Refer to "42" Mower Deck Removal" on page 7-64.
2. Remove the spring from the idler and brake bracket assemblies (Fig. 541).



Fig 541

PICT-7759

3. Remove the hairpin cotter from the brake rod (Fig. 542).

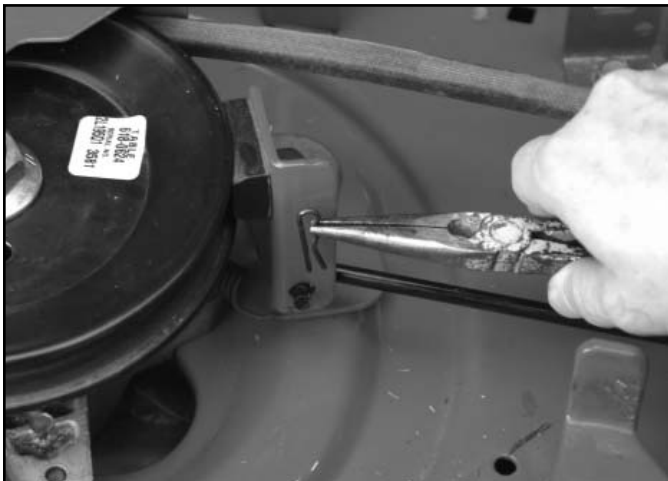

Fig 542

PICT-7784

4. Remove the brake rod from the brake assembly bracket (Fig. 543).



Fig 543

PICT-7786

5. Remove the bolt, washer, nut and belt keeper rod from the front idler (Fig. 544).



Fig 544

PICT-7765

# MOWER DECK

6. Remove the idler pulley (Fig. 545).



Fig 545

PICT-7766

8. Remove the brake idler bracket assembly from the mower deck (Fig. 547).

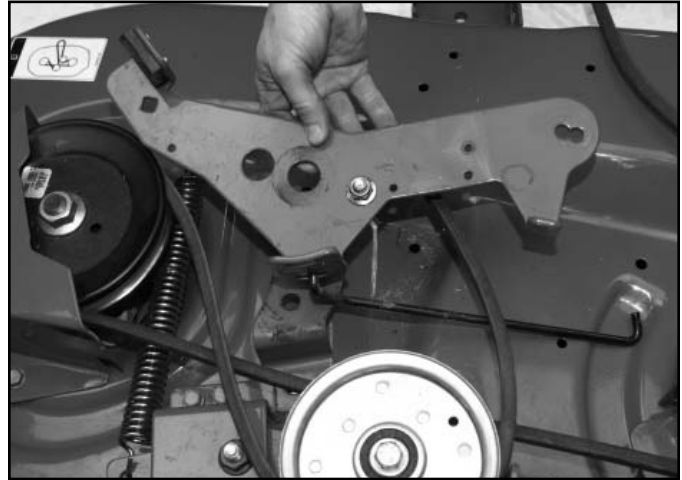

Fig 547

PICT-7771

7. Remove the bolt, shoulder spacer and nut securing the brake idler bracket assembly to the mower deck (Fig. 546).



Fig 546

PICT-7768

9. Remove the brake rod from the brake idler bracket (Fig. 548).



Fig 548

PICT-7775

7

10. Remove the stop bolt and nut from the brake idler bracket (Fig. 549).



Fig 549

PICT-7776

2. Install the brake rod into the brake idler bracket (Fig. 551).



Fig 551

PICT-7775

## 42" Mower Deck - Brake Idler Assembly Replacement

### Installation

1. Install the stop bolt and nut into the brake idler bracket (Fig. 550).



Fig 550

PICT-7776

3. Apply grease to the brake idler mounting bracket (Fig. 552).

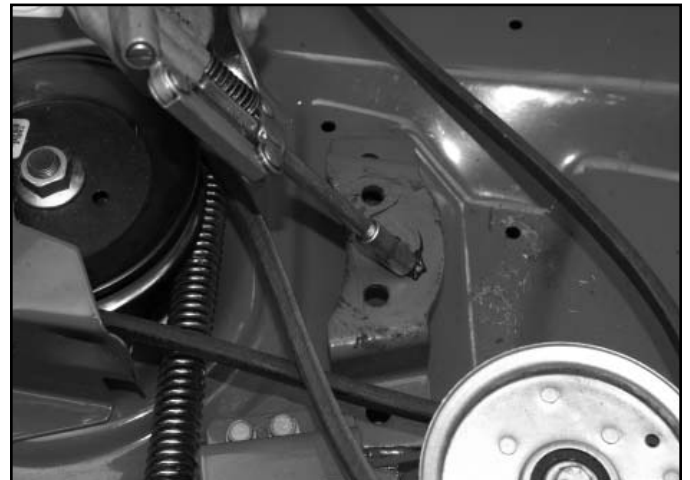

Fig 552

PICT-7777

# MOWER DECK

4. Insert the shoulder spacer and bolt into the brake idler bracket (Fig. 553).



Fig 553

PICT-7778

6. Install a nut onto the bolt (Fig. 555).



Fig 555

PICT-7768

5. Position the brake idler bracket assembly onto the mounting bracket on the mower deck so that the bolt is inserted through the middle hole on the mounting bracket (Fig. 554).

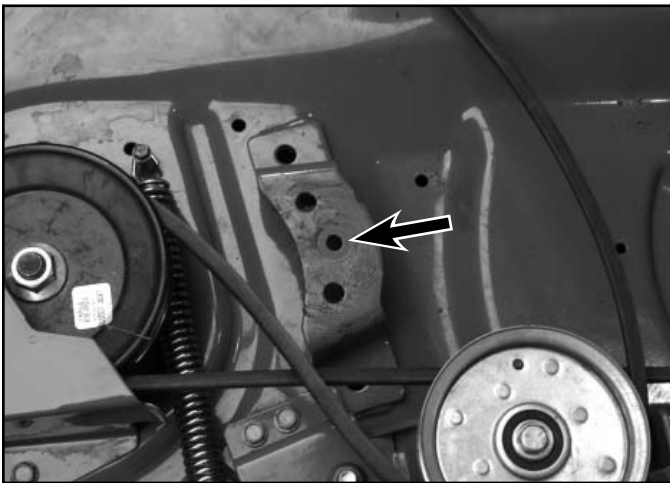

Fig 554

PICT-9685

7. Install a bolt, washer, and belt keeper rod into the idler pulley (Fig. 556).



Fig 556

PICT-7789

# MOWER DECK

8. Position the idler pulley assembly into the idler bracket assembly in the hole indicated (Fig. 557).

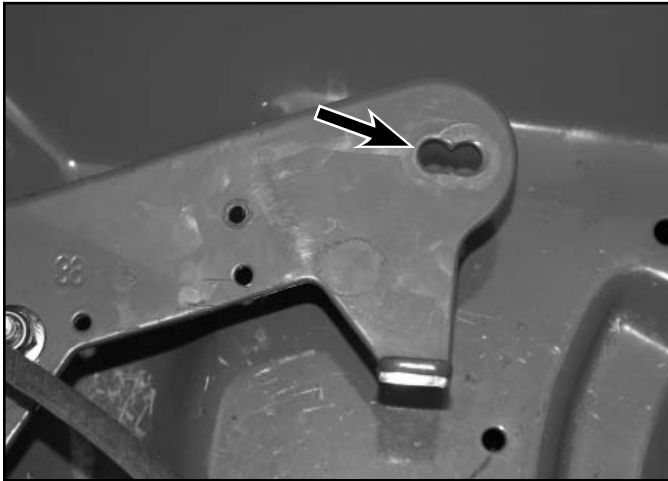

Fig 557

PICT-7779

10. Install and tighten the nut onto the idler bolt (Fig. 559).



Fig 559

PICT-7765

9. Route the belt around the idler pulley and behind the belt keeper rod (Fig. 558).



Fig 558

PICT-7818

11. Install the brake rod into the brake assembly bracket (Fig.560).



Fig 560

PICT-7786

# MOWER DECK

12. Install a hairpin cotter into the brake rod (Fig. 561).

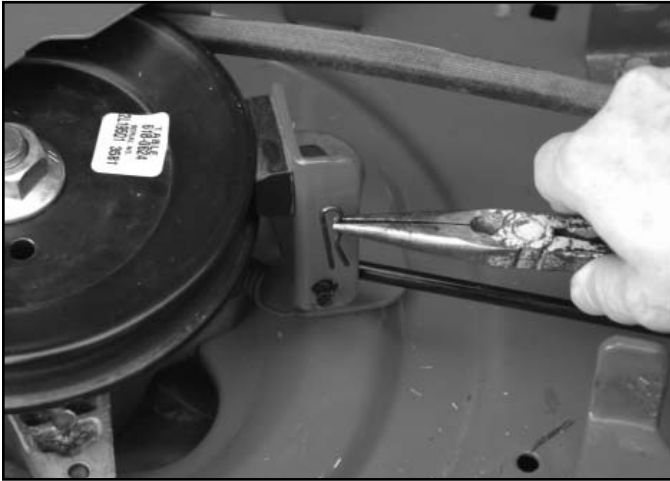

Fig 561

PICT-7784

13. Install the spring into the idler and brake bracket assemblies (Fig. 562).



Fig 562

PICT-7759

## 42" Mower Deck - Idler Assembly Replacement

### Removal

1. Remove the spring from the idler and brake bracket assemblies (Fig. 563).



Fig 563

PICT-7759

2. Remove the idler bracket spring from the stud on the mower deck (Fig. 564).

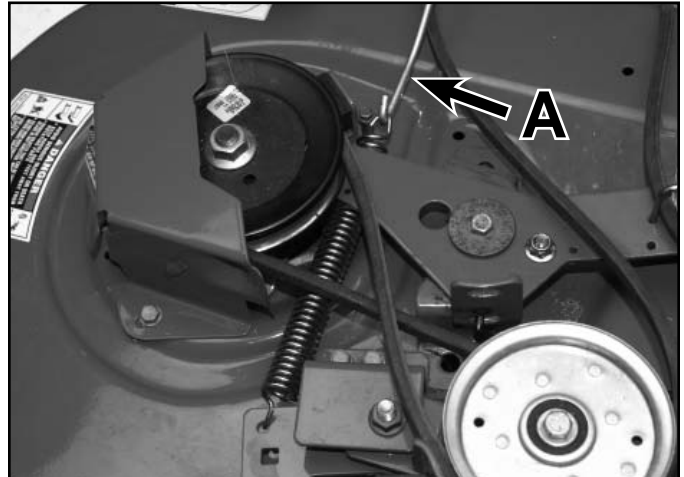

Fig 564

PICT-7795

A. Spring removal tool (Toro P/N 92-5771)



# MOWER DECK

3. Remove the nut securing the idler pulley to the idler bracket (Fig. 565).

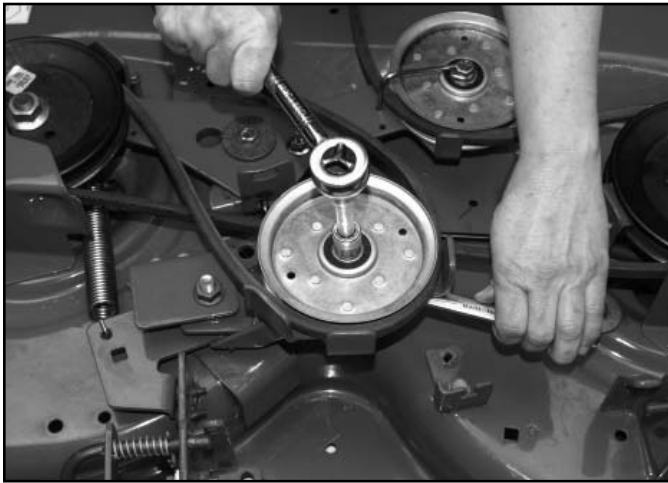

Fig 565

PICT-7796

5. Remove the 2 self-tapping screws and lock washers securing the idler bracket to the mower deck (Fig. 567).

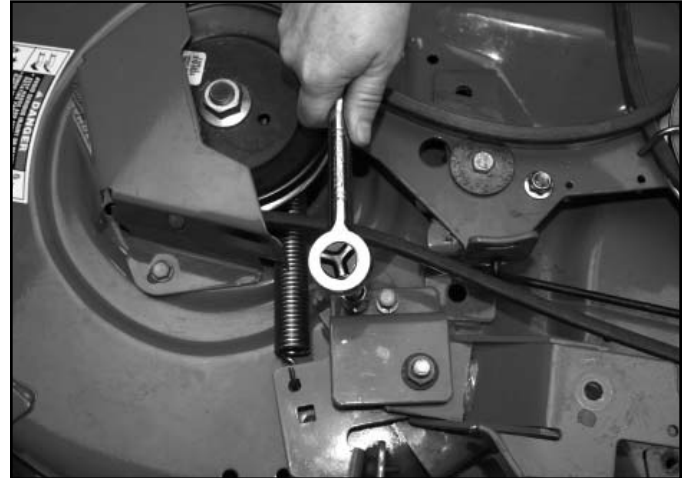

Fig 567

PICT-7799

4. Remove the pulley assembly from the idler bracket (Fig. 566).

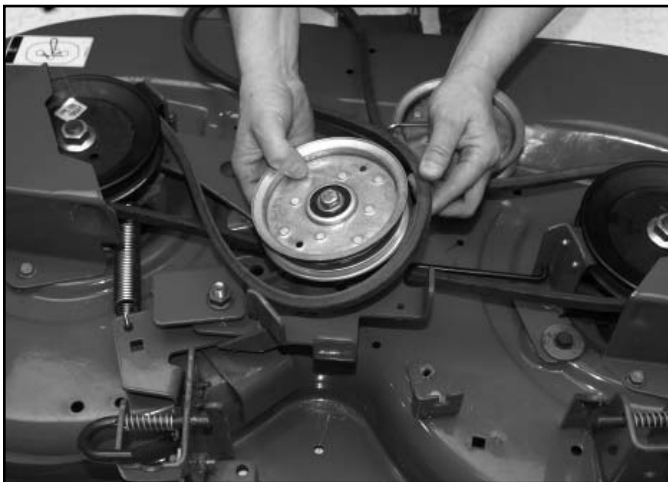

Fig 566

PICT-7797

6. Remove the nut from the bolt securing the idler bracket to the mower deck (Fig. 568).

**Note:** The bolt and washer will fall through to the underside of the mower deck.



Fig 568

PICT-7801

# MOWER DECK

8. Remove the pivot support bracket (Fig. 569).

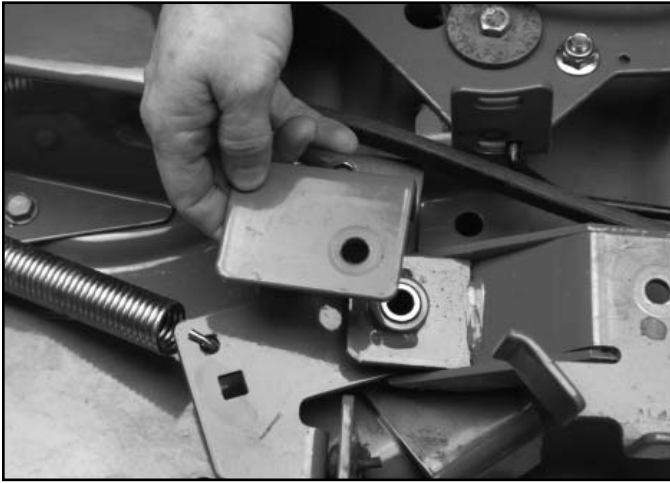

Fig 569

PICT-7802

10. Remove the spacer from the idler bracket (Fig. 571).

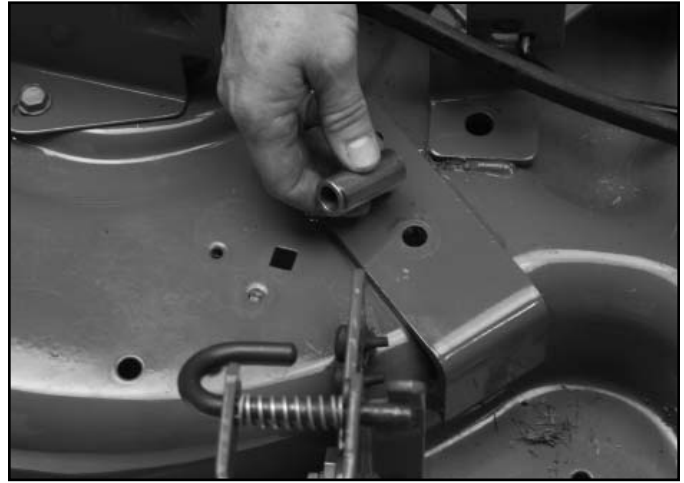

Fig 571

PICT-7805

9. Remove the idler bracket from the mower deck (Fig. 570).

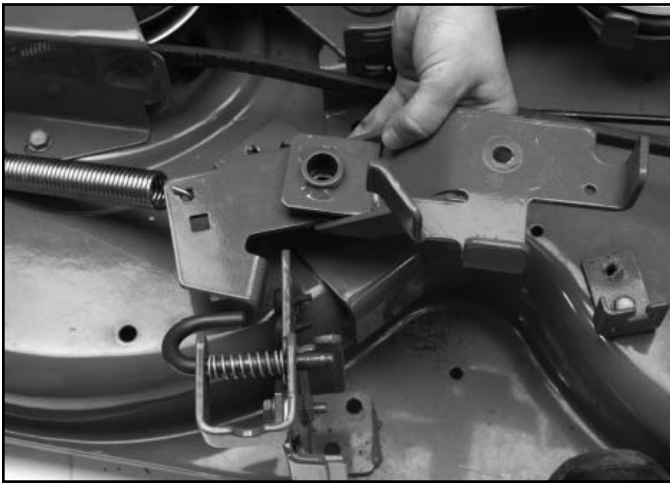

Fig 570

PICT-7803

## 42" Mower Deck - Idler Assembly Replacement

### Installation

1. Raise and support the rear left corner of the mower deck.
2. Apply grease to the outside of the spacer (Fig. 572).



Fig 572

PICT-7807

7

# MOWER DECK

3. Insert the greased spacer into the idler bracket (Fig. 573).



Fig 573

PICT-7808

5. While supporting the bolt, install the pivot support bracket onto the bolt (Fig. 575).



Fig 575

PICT-7814

4. Insert a bolt and washer from the underside of the mower deck, up through the idler bracket spacer (Fig. 574).



Fig 574

PICT-7811

6. Continue to supporting the bolt and loosely install a nut onto the bolt (Fig. 576).



Fig 576

PICT-7816

# MOWER DECK

7. Install 2 self-tapping screws and lock washers to secure the pivot support bracket to the mower deck (Fig. 577).

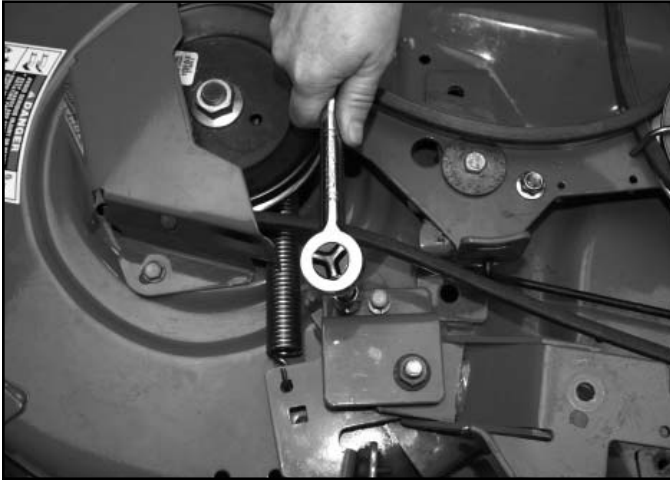

Fig 577

PICT-7799

9. Route the belt around the idler pulley and install the idler pulley assembly to the idler bracket (Fig. 579).



Fig 579

PICT-7797

8. Tighten the nut securing the idler bracket assembly to the mower deck (Fig. 578).



Fig 578

PICT-7801

10. Install a nut onto the bolt securing the idler pulley to the idler bracket (Fig. 580).

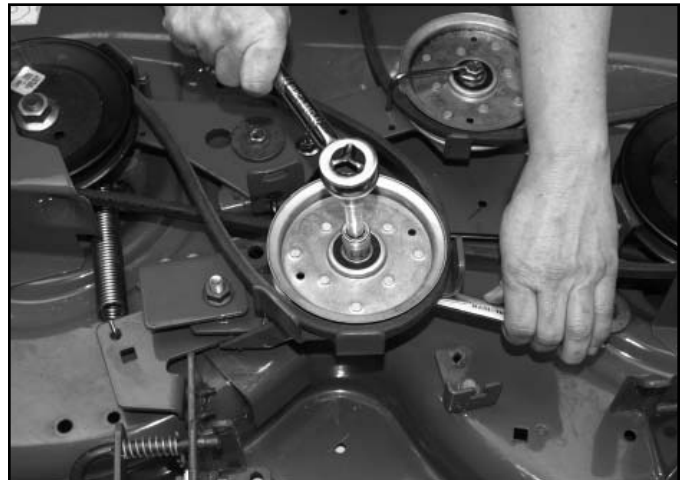

Fig 580

PICT-7796

11. Install the idler bracket spring to the stud on the mower deck (Fig. 581).

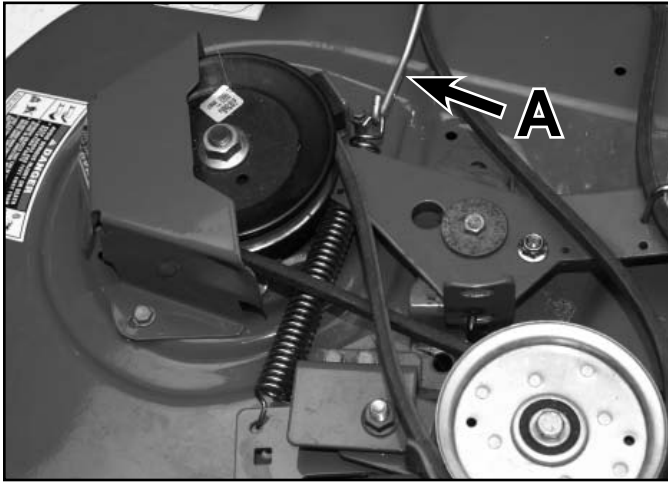

Fig 581

PICT-7795

- A. Spring removal tool (Toro P/N 92-5771)

12. Install the spring to the idler and brake bracket assemblies (Fig. 582).



Fig 582

PICT-7759

13. Install the mower deck. Refer to "42" Mower Deck Installation" on page 7-67.

## 42" Mower Belt Replacement

### Removal

1. Remove the mower deck from the tractor. Refer to "42" Mower Deck Removal" on page 7-64.
2. Remove the 3 self-tapping screws securing the left hand belt cover to the mower deck (Fig. 583).



Fig 583

PICT-9774

3. Remove the left hand belt guard from the mower deck (Fig. 584).



Fig 584

PICT-9775

# MOWER DECK

4. Remove the 3 self-tapping screws securing the right hand belt cover to the mower deck (Fig. 585).

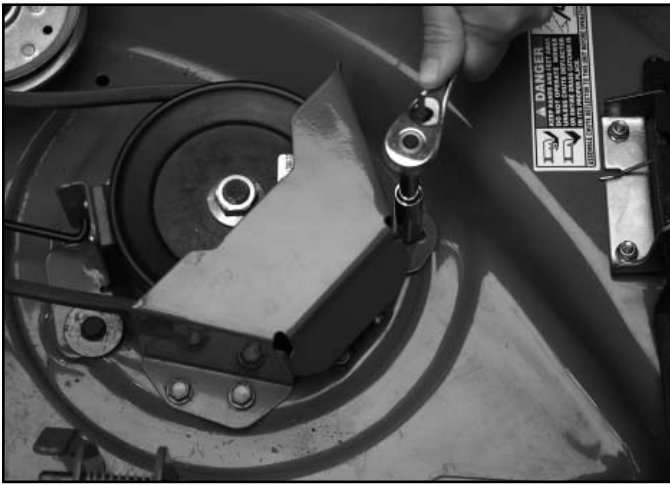

Fig 585

PICT-9776

6. Loosen, but do not remove, the screw and nut securing the two idler pulleys (Fig. 587).



Fig 587

PICT-9778

5. Remove the right hand belt cover from the mower deck (Fig. 586).



Fig 586

PICT-9777

7. Relieve tension from the deck brake assembly and remove the deck belt from around all the pulleys (Fig. 588).

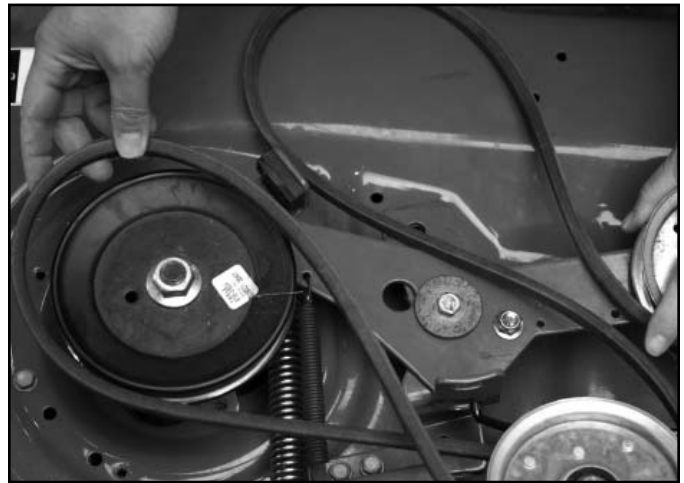

Fig 588

PICT-9779

7

## Installation

1. Route a new belt around the pulleys as shown (Fig. 589).

**Note:** Tension must be released from the deck brake assembly to rout the belt around the left pulley.

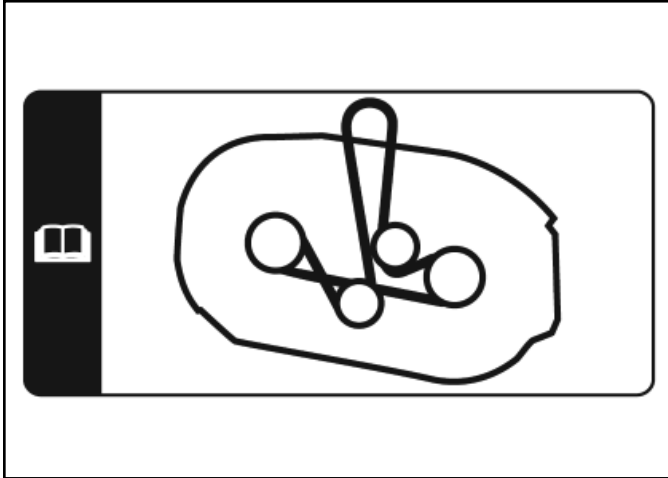

Fig 589 fig. LX420 112-1270

2. Secure the two idler pulleys by tightening the screws and nuts (Fig. 590).



Fig 590 PICT-9778

3. Position the right belt cover onto the mower deck (Fig. 591).



Fig 591 PICT-9777

4. Install the 3 self-tapping screws to secure the belt cover to the mower deck (Fig. 592).

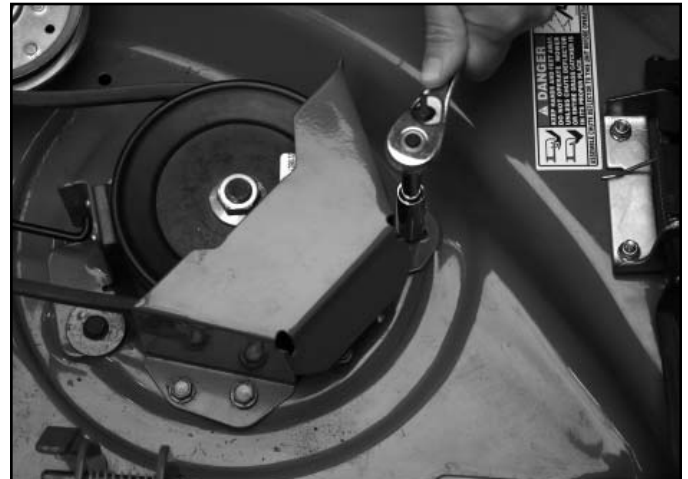

Fig 592 PICT-9776

# MOWER DECK

5. Position the left belt cover onto the mower deck (Fig. 593).

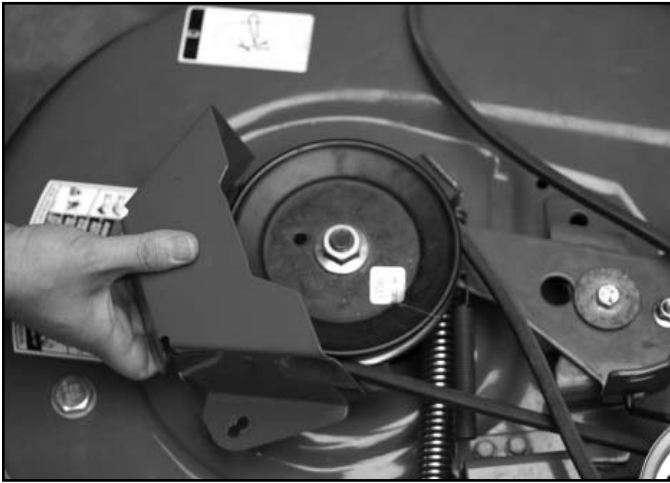

Fig 593

PICT-9775

6. Install the 3 self-tapping screws to secure the left belt cover to the mower deck (Fig. 594).

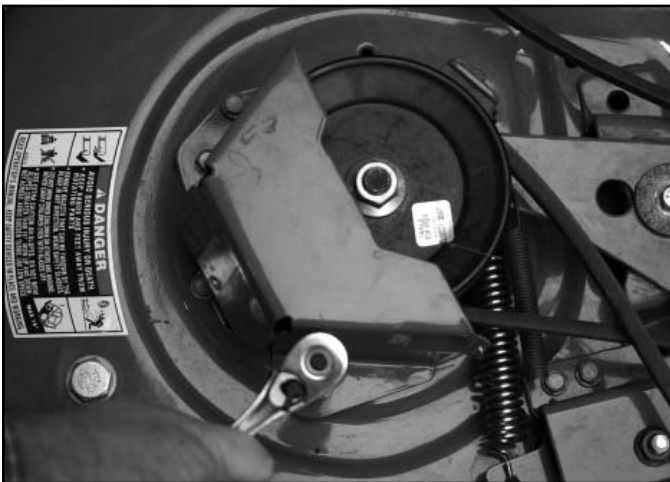

Fig 594

PICT-9774

7. Install the Mower Deck onto the tractor. Refer to "42" Mower Deck Installation" on page 7-67.

## 46" Mower Deck - RH Idler Bracket Assembly

### Removal

1. Remove the mower Deck from the tractor. Refer to "46" Mower Deck Removal" on Page 7-69.
2. Remove the 3 self-tapping screws securing the left mower deck belt cover to the mower deck (Fig. 595).

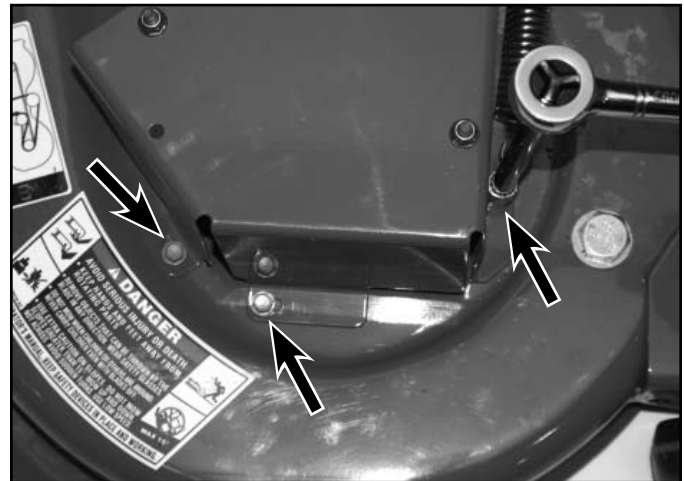

Fig 595

PICT-7835

3. Remove the mower deck belt cover from the mower deck (Fig. 596).



Fig 596

PICT-7839



# MOWER DECK

- Loosen the 2 nuts on the upper idler pulley bolts (Fig. 597).

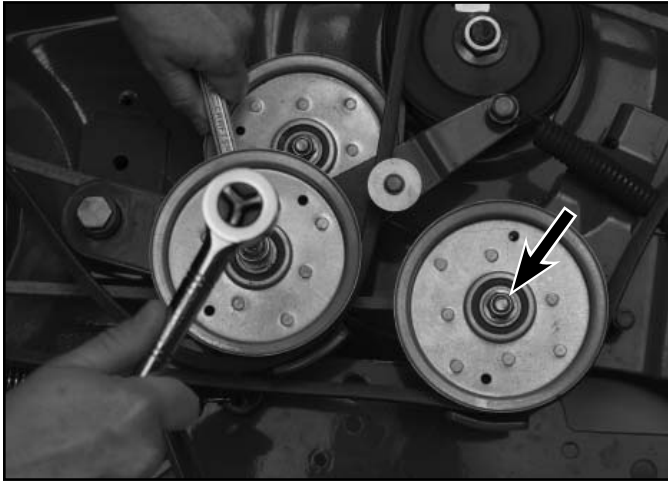

Fig 597

PICT-7840a

- Remove the extension spring between the brake arm and then right hand side belt cover (Fig. 599).

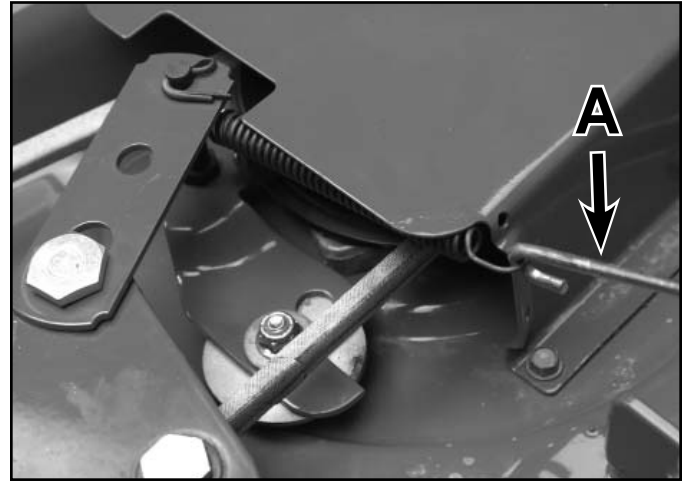

Fig 599

PICT-7851

- Tilt both idler pulleys and remove the upper mower deck belt from the mower deck (Fig. 598).



Fig 598

PICT-7841

- Remove the extension spring located between the left and right idler brackets (Fig. 600).

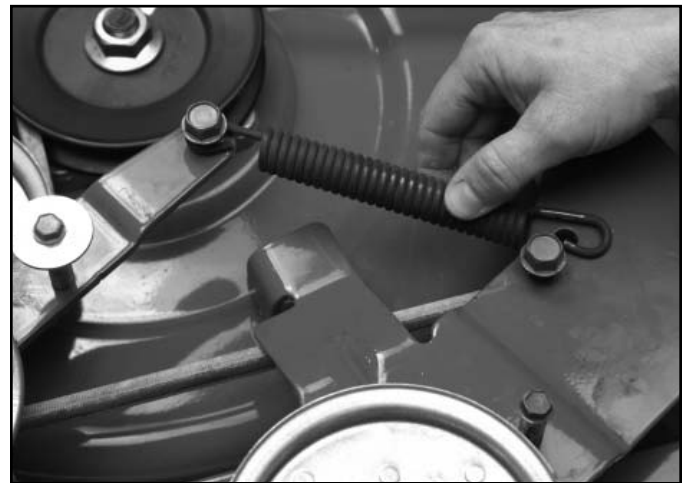

Fig 600

PICT-7854

# MOWER DECK

8. Remove the shoulder bolt between the brake bracket and the right hand idler bracket (Fig. 601).

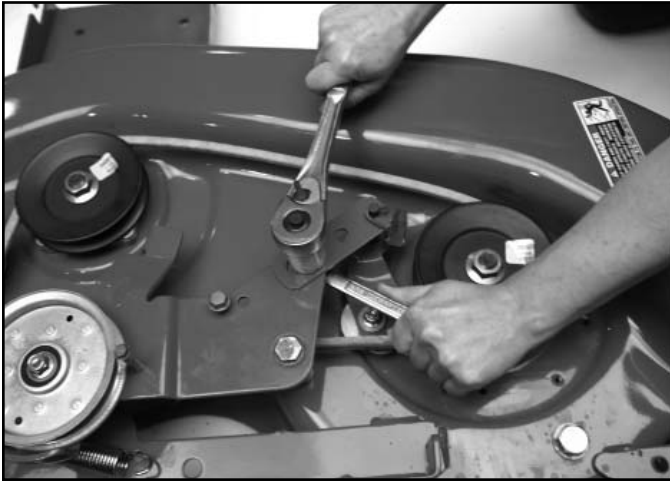

Fig 601

PICT-7858

9. Place two 4 x 4 wooden blocks, or equivalent, to raise and support the rear of the mower deck.
10. Remove the shoulder bolt and nut retaining the right hand idler bracket to the mower deck (Fig. 602).

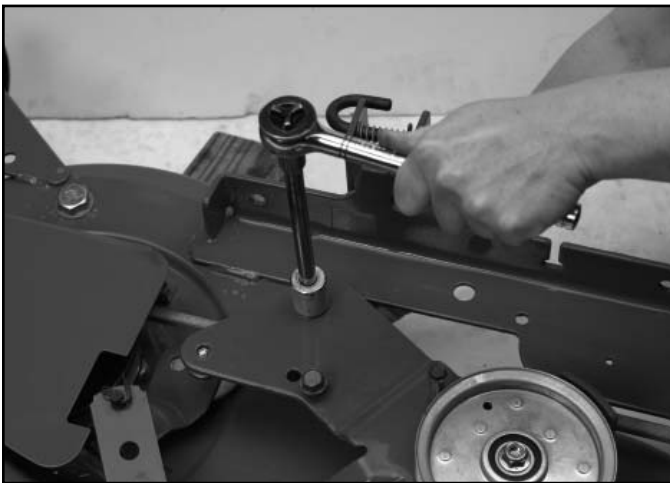

Fig 602

PICT-7886

11. Remove the right hand idler bracket (Fig. 603).

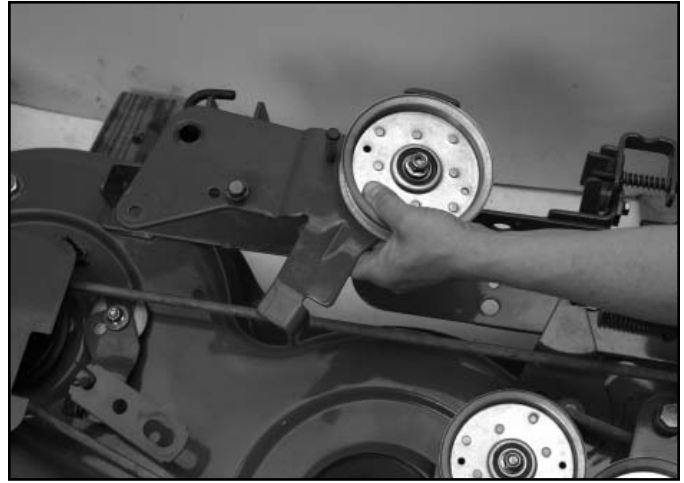

Fig 603

PICT-7885

## 46" Mower Deck - RH Idler Bracket Assembly

### Installation

1. Apply a small quantity of No. 2 multi-purpose lithium grease, around the shoulder bolt (Fig. 604).



Fig 604

PICT-7869

# MOWER DECK

2. Install the shoulder bolt and nut through the right hand idler bracket and the mower deck (Fig. 605).

**Note:** Make sure the lower mower belt is routed to the inside of the right hand idler bracket assembly where it is mounted to the mower deck.

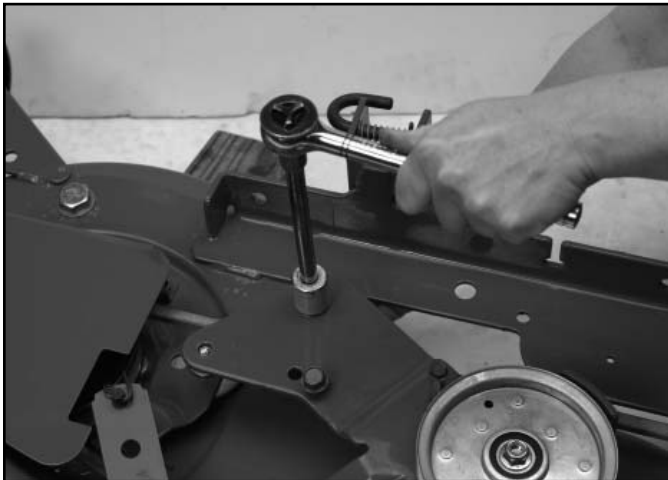

Fig 605

PICT-7886

3. Install the shoulder bolt between the brake bracket and the right hand idler bracket. Tighten the bolt and nut (Fig. 606).

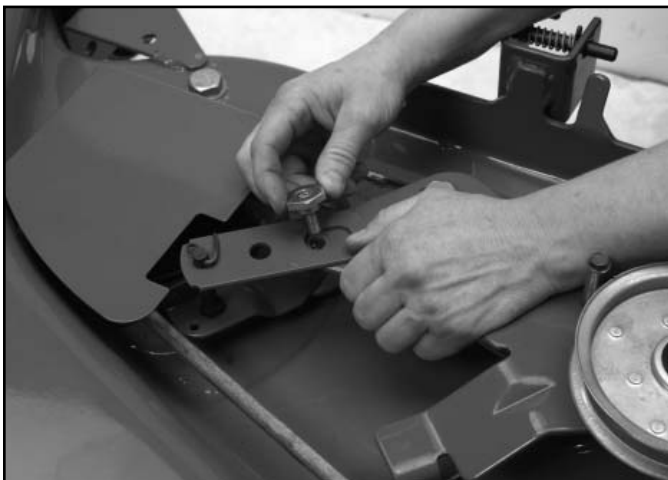

Fig 606

PICT-7888

4. Install the extension spring between the left and right idler brackets (Fig. 607).

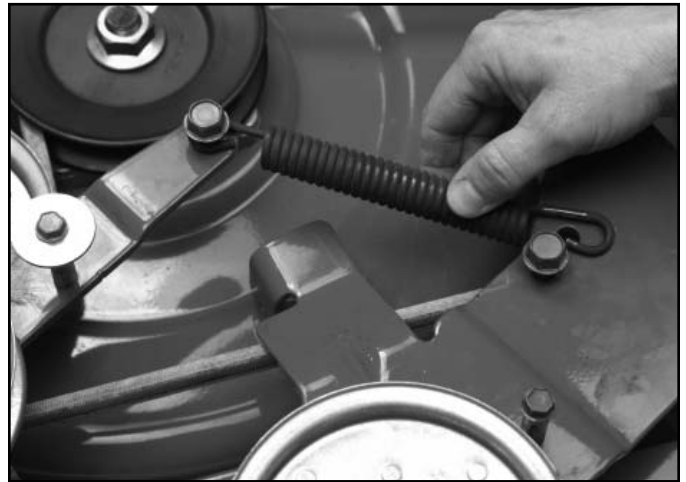

Fig 607

PICT-7854

5. Install the extension spring between the brake arm and the right hand side belt cover (Fig. 608).

**Note:** The extension spring installs in the upper hole on the belt cover.



Fig 608

PICT-7851

- A. Spring removal tool (Toro P/N 92-5771)

# MOWER DECK

6. Tilt both idler pulleys and install the upper mower deck belt around the idler pulleys and the top groove of the left side mower spindle pulley (Fig. 609).

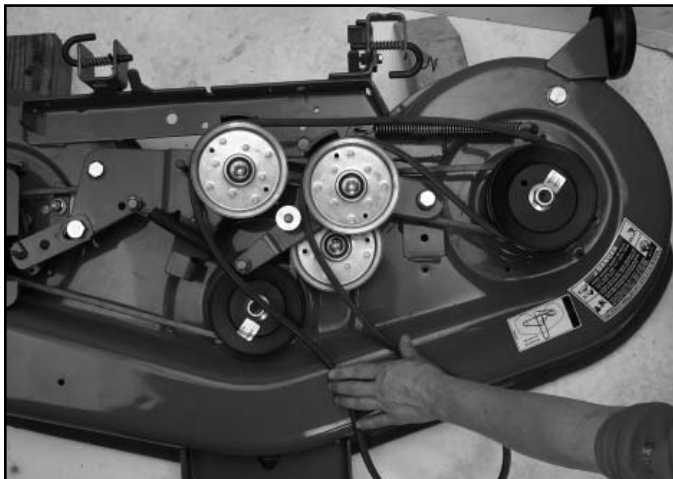

Fig 609

PICT-7889

7. Tighten the bolts and nuts retaining the idler pulleys (Fig. 610).



Fig 610

PICT-7840a

8. Install the left hand mower belt cover (Fig. 611).



Fig 611

PICT-7839

9. Install 3 self-tapping screws securing the belt cover to the mower deck (Fig. 612).

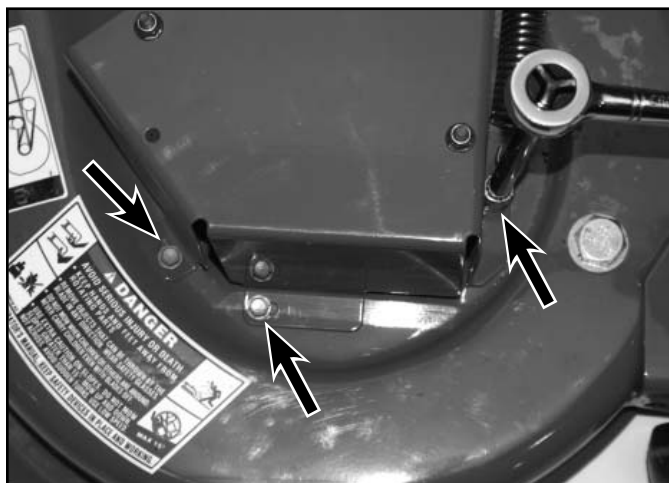

Fig 612

PICT-7835

10. Remove the 4x4 wooden blocks from under the mower deck.
11. Install the mower deck to the tractor. Refer to "46" Mower Deck Installation" on page 7-72.

## 46" Mower Deck - Brake Assembly

### Removal

1. Remove the mower deck from the tractor. Refer to "46" Mower Deck Removal", page 7-69.
2. Remove the extension spring between the right hand belt cover and the brake pin (Fig. 613).

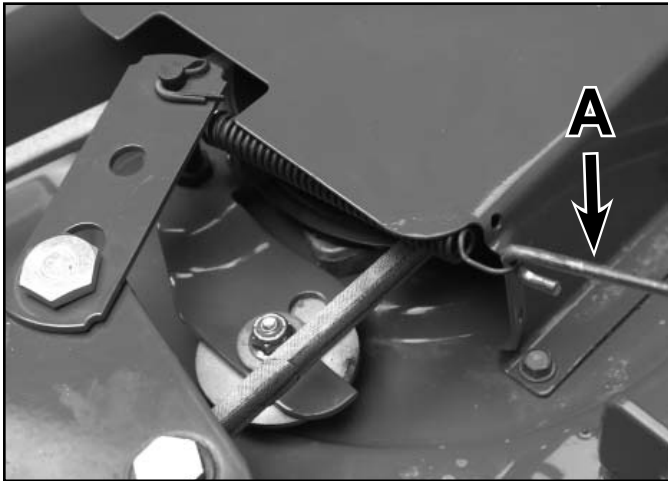

Fig 613 PICT-7851

- A. Spring removal tool (Toro P/N 92-5771)
3. Remove the shoulder bolt and nut from the brake bracket and the right hand idler bracket (Fig. 614).



Fig 614 PICT-7914

4. Loosen and remove the bolt and nut from the brake assembly bracket (Fig. 615).



Fig 615 PICT-7915

5. Remove the small shoulder spacer and the brake bracket from the deck (Fig. 616).

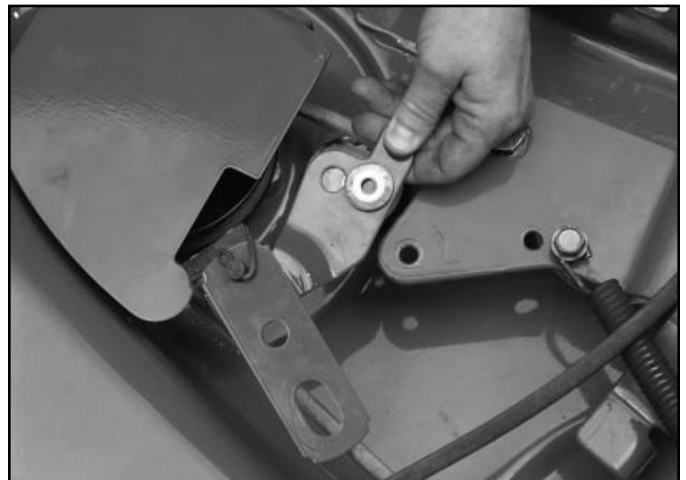

Fig 616 PICT-7916

# MOWER DECK

6. Remove the large shoulder spacer from the mower deck (Fig. 617).



Fig 617

PICT-7917

2. Install the brake bracket assembly and the small shoulder spacer to the deck (Fig. 619).

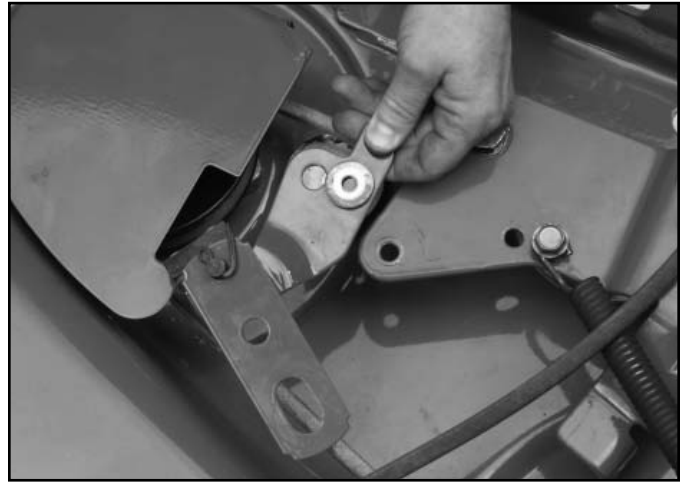

Fig 619

PICT-7916

## 46" Mower Deck - Brake Assembly

### Installation

1. Install the large shoulder spacer on the mower deck (Fig. 618).

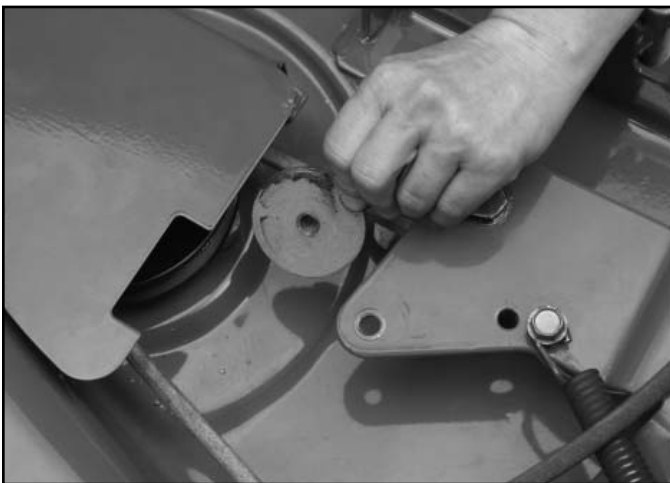

Fig 618

PICT-7917

3. Install the bolt and nut through the brake bracket assembly to the mower deck (Fig. 620).

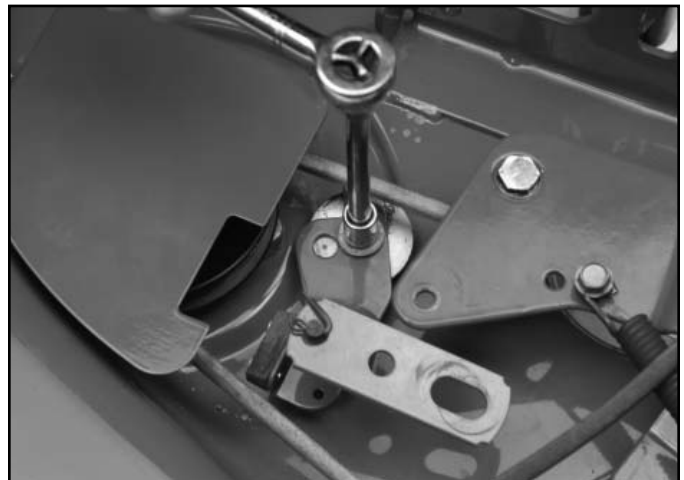

Fig 620

PICT-7915

7

# MOWER DECK

4. Install the shoulder bolt and nut securing the brake assembly bracket to the right hand idler bracket (Fig. 621).



Fig 621

PICT-7914

5. Install the extension spring from the brake pin to the right hand belt cover (Fig. 622).

**Note:** The extension spring goes into the top hole of the belt guard.



Fig 622

PICT-7651

- A. Spring removal tool (Toro P/N 92-5771)

6. Install the mower deck to the tractor. Refer to "46" Mower Deck Installation" on page 7-72.

## 46" Mower Deck - LH Idler Assembly

### Removal

1. Remove the mower Deck from the tractor. Refer to "46" Mower Deck Removal" on page 7-69.
2. Remove the 3 self-tapping screws securing the left mower deck belt cover to the mower deck (Fig. 623).

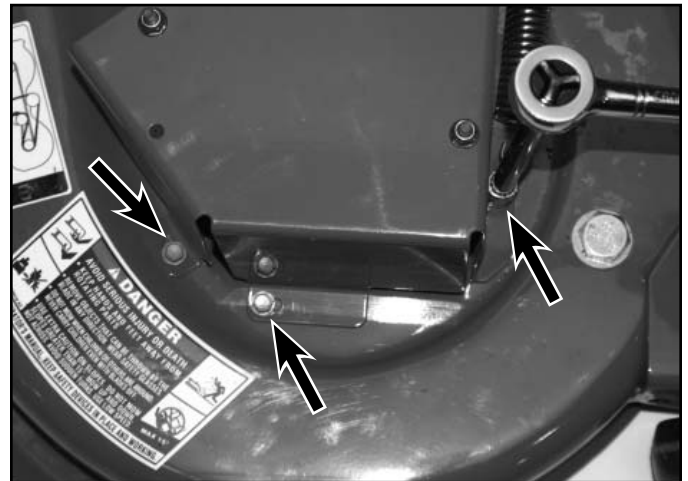

Fig 623

PICT-7835

3. Remove the mower deck belt cover from the mower deck (Fig. 624).



Fig 624

PICT-7839

# MOWER DECK

- Loosen the 2 nuts on the upper idler pulley bolts (Fig. 625).

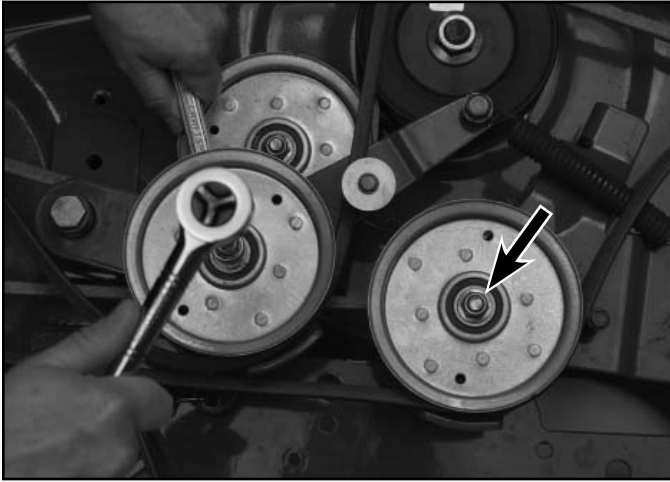

Fig 625

PICT-7840

- Remove the extension spring (located between the right and left idler bracket assemblies) from the right hand idler assembly (Fig. 627).

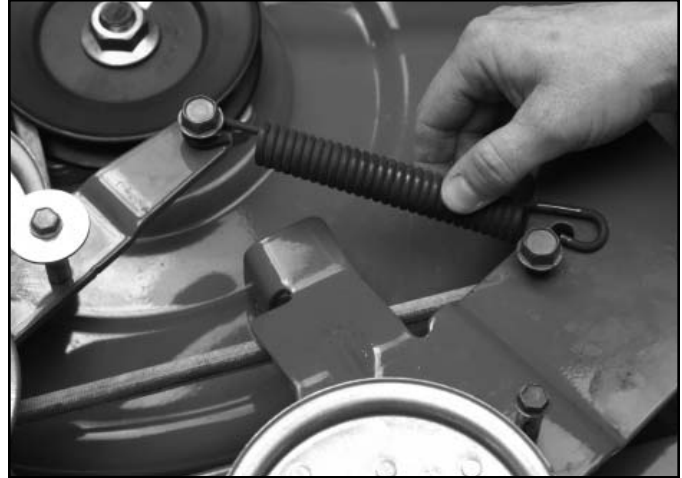

Fig 627

PICT-7854

- Tilt both idler pulleys and remove the upper mower deck belt from the idler pulleys and the left hand mower spindle pulley (Fig. 626).

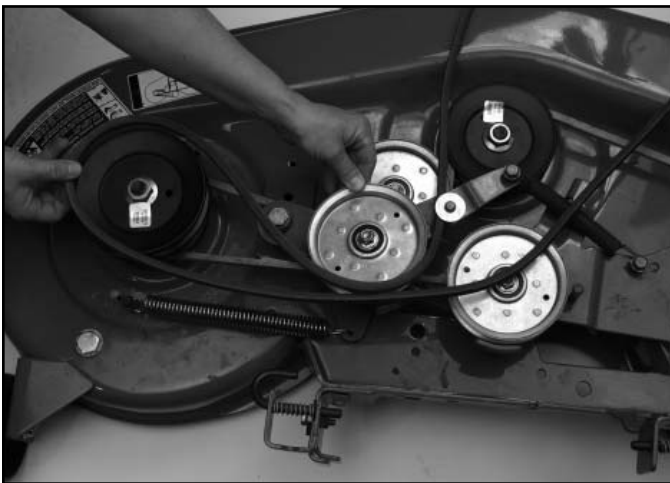

Fig 626

PICT-7842

- Raise the rear side of the mower deck.
- Remove the shoulder bolt and nut securing the left hand idler bracket to the mower deck (Fig. 628).



Fig 628

PICT-7890



# MOWER DECK

9. Remove the left hand idler assembly from the mower deck (Fig. 629).



Fig 629

PICT-7895

2. Install the left hand idler bracket to the mower deck with the shoulder bolt and nut. Tighten the shoulder bolt and nut (Fig. 631).

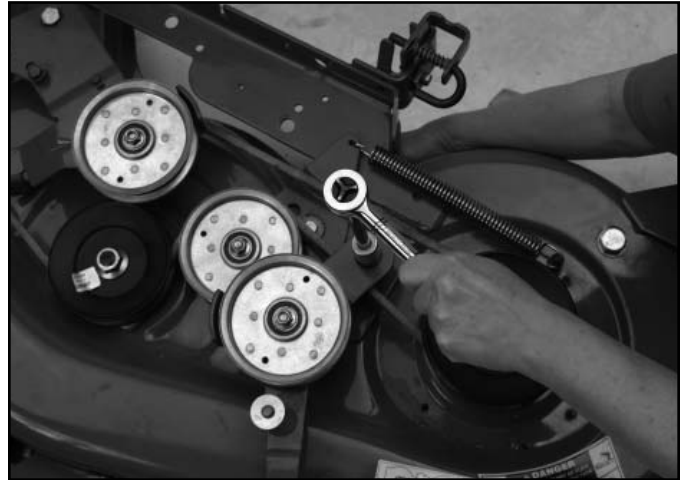

Fig 631

PICT-7890

## 46" Mower Deck - LH Idler Assembly

### Installation

1. Apply No. 2 multi-purpose lithium grease to the shoulder surface of the shoulder bolt (Fig. 630).



Fig 630

PICT-7869

3. Hook the extension spring to the right idler bracket assembly (Fig. 632).

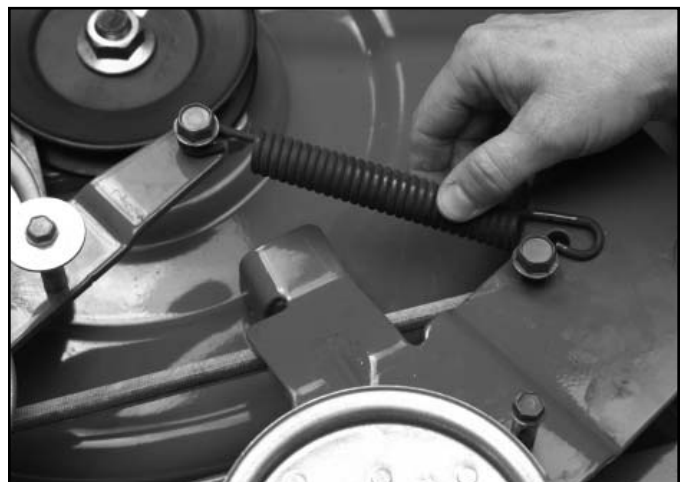

Fig 632

PICT-7854

# MOWER DECK

4. Route the upper mower belt around the left hand mower spindle pulley and the two idler pulleys (Fig. 633).

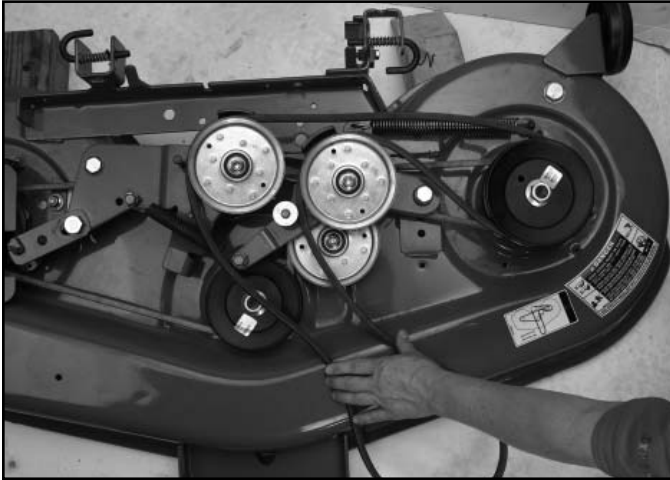

Fig 633

PICT-7889

6. Position the left hand mower deck belt cover onto the mower deck (Fig. 635).



Fig 635

PICT-7839

5. Tighten the two nuts on the upper idler pulleys (Fig. 634).

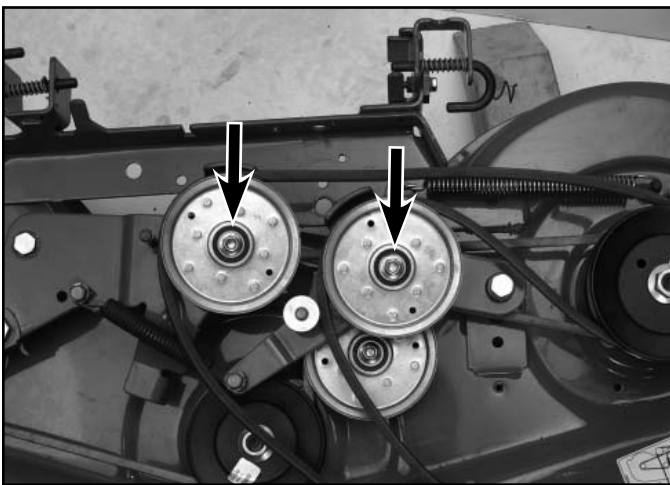

Fig 634

PICT-7889

7. Install 3 self-tapping screws securing the left hand mower deck belt cover to the mower deck (Fig. 636).

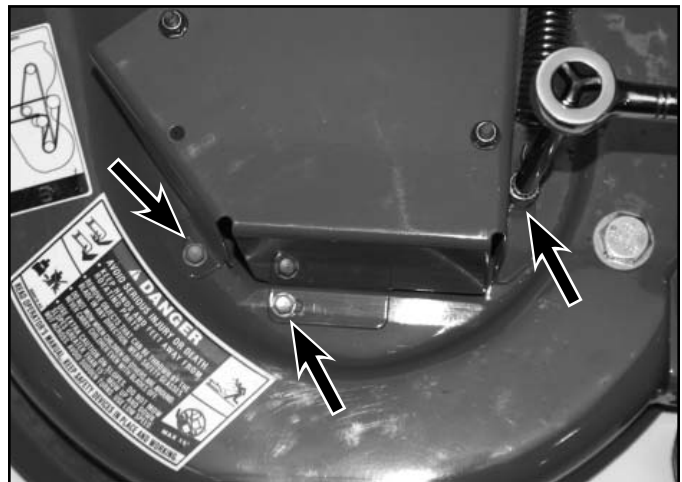

Fig 636

PICT-7835

8. Lower the mower deck so it is resting flat.
9. Install the mower deck to the tractor. Refer to "46" Mower Deck Installation" on page 7-72.

## 46" Mower Deck - Lower Idler Bracket

### Removal

1. Remove the mower deck from the tractor. Refer to "46" Mower Deck Removal" on page 7-69.
2. Using 4x4 wooden blocks, or equivalent, raise the rear of the mower deck off the floor.
3. Remove the large extension spring hooked from the mower deck and lower idler bracket (Fig. 637).

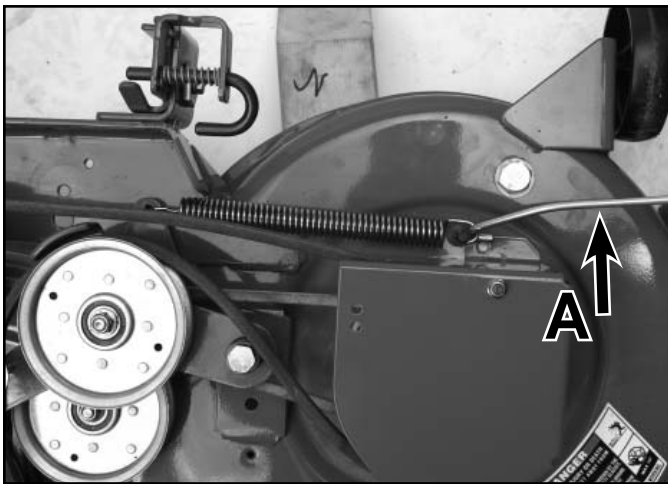

Fig 637

PICT-7898

- A. Spring removal tool (Toro P/N 92-5771)

4. Remove the extension spring between the right and left idler brackets (Fig. 638).

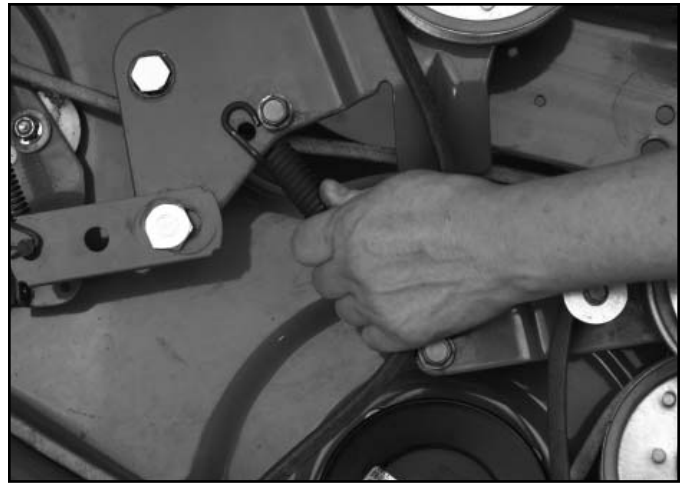

Fig 638

PICT-7900

5. Remove the bolt, shoulder spacer, and nut that secures the lower idler bracket to the mower deck (Fig. 639).



Fig 639

PICT-7902

# MOWER DECK

6. Remove the lower idler bracket from the mower deck (Fig. 640).



Fig 640

PICT-7906

## 46" Mower Deck - Lower Idler Bracket

### Installation

1. Apply No. 2 multi-purpose lithium grease to the bottom of the lower idler bracket (Fig. 641).



Fig 641

PICT-7909

2. Install the lower bracket (Fig. 642) making sure:
  - A. Flat side of the lower belt is in the flat idler.
  - B. The belt is routed around the left side, lower spindle pulley.
  - C. The shoulder spacer is inserted in the hole of the idler bracket, so the shoulder of the spacer is sitting evenly on top of the mower deck.

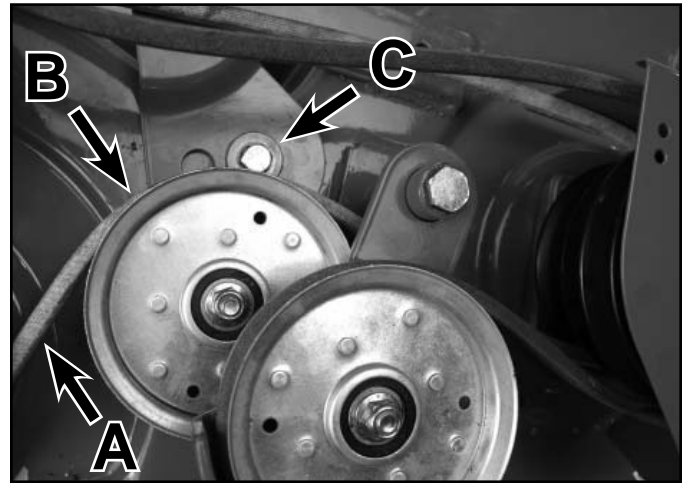

Fig 642

PICT-7912

3. Hook the extension spring to the right and left idler brackets (Fig. 643).

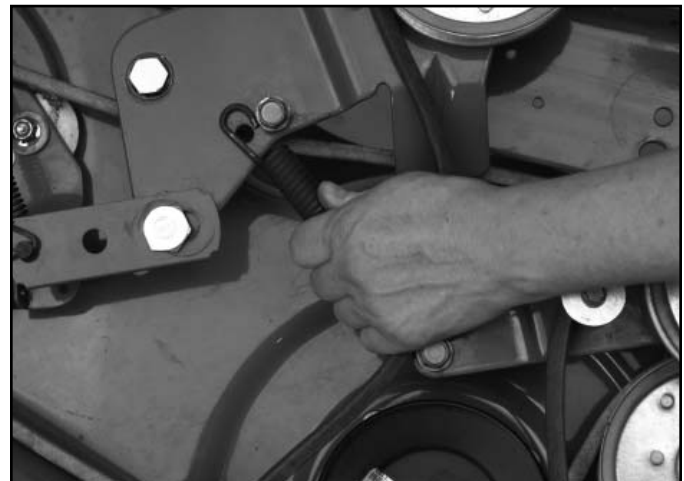

Fig 643

PICT-7900

# MOWER DECK

4. Install the large idler extension spring into the lower idler bracket (Fig. 644).

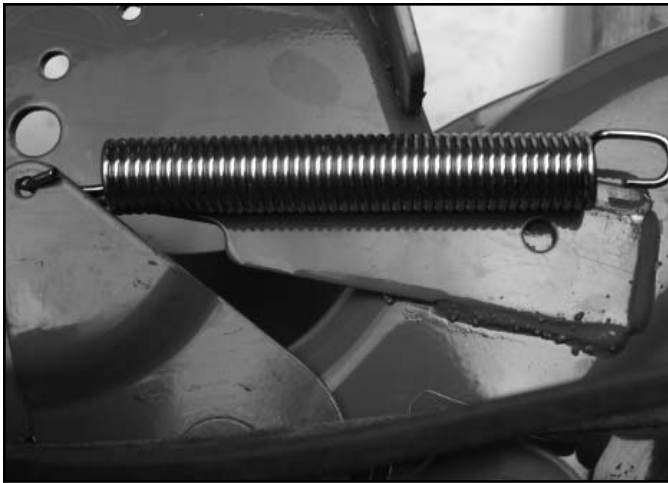

Fig 644

PICT-7913

5. Install the other end of the large idler extension spring to the spring post on the mower deck (Fig. 645).

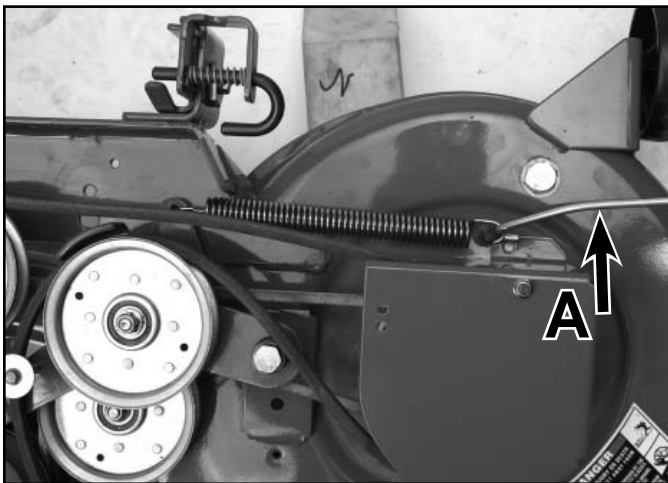

Fig 645

PICT-7898

- A. Spring removal tool (Toro P/N 92-5771)

6. Lower the back of the mower deck to the floor.
7. Install the mower deck to the tractor. Refer to "46" Mower Deck Installation" on page 7-72.

## 46" Mower Deck - Lower Mower Deck Belt Replacement

### Removal

1. Remove the mower deck from the tractor. Refer to "46" Mower Deck Removal" on page 7-69.
2. Remove the 3 self-tapping screws securing the left mower deck belt cover to the mower deck (Fig. 646).

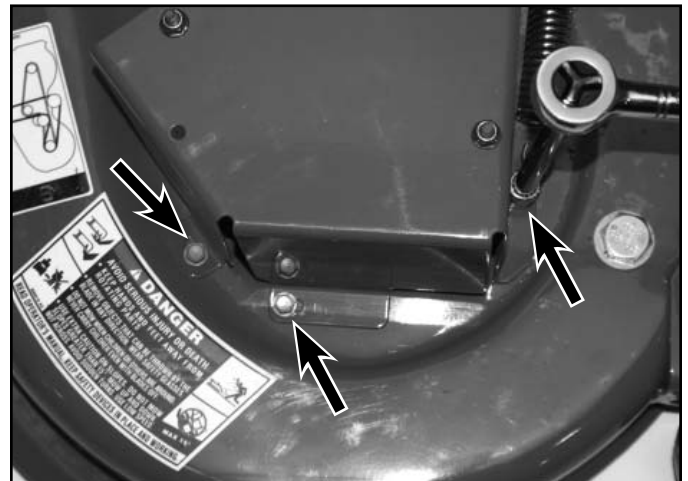

Fig 646

PICT-7835

3. Remove the mower deck belt cover from the mower deck (Fig. 647).



Fig 647

PICT-7839

# MOWER DECK

- Loosen the nut on the two upper idler pulley bolts (Fig. 648).

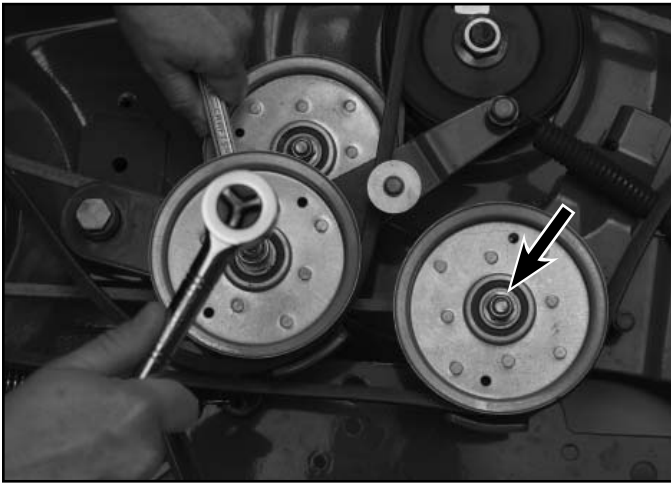

Fig 648

PICT-7840a

- Remove the spring from the right side mower deck belt cover and the brake bracket pin (Fig. 650).

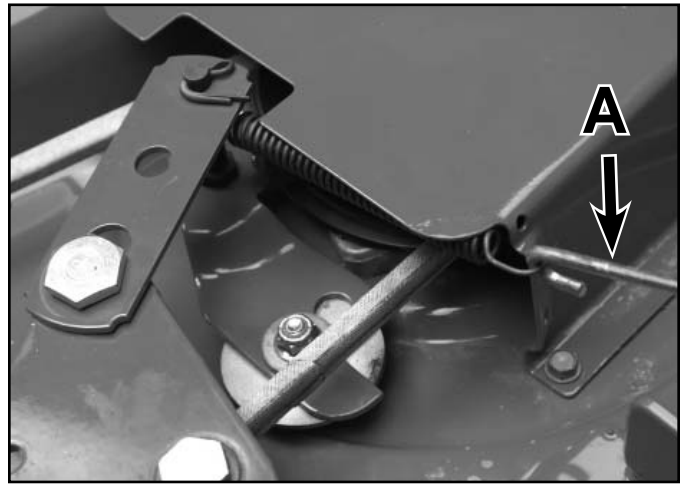

Fig 650

PICT-7851

- Tilt both idler pulleys and remove the upper mower deck belt from the mower deck (Fig. 649).

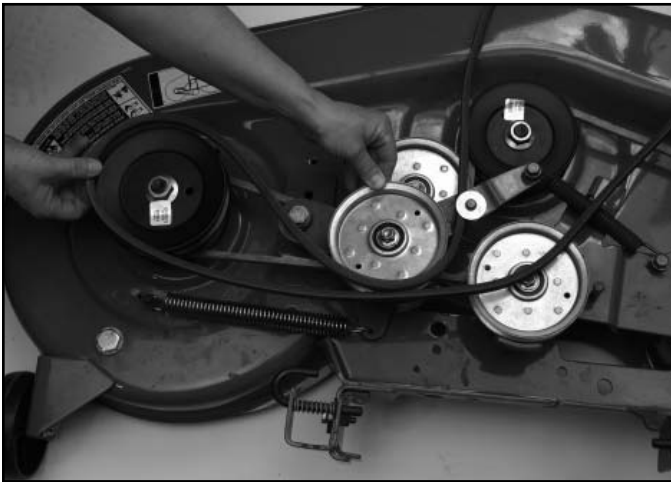

Fig 649

PICT-7842

- Remove the 3 self-tapping screws retaining the right mower deck belt cover to the mower deck (Fig. 651).

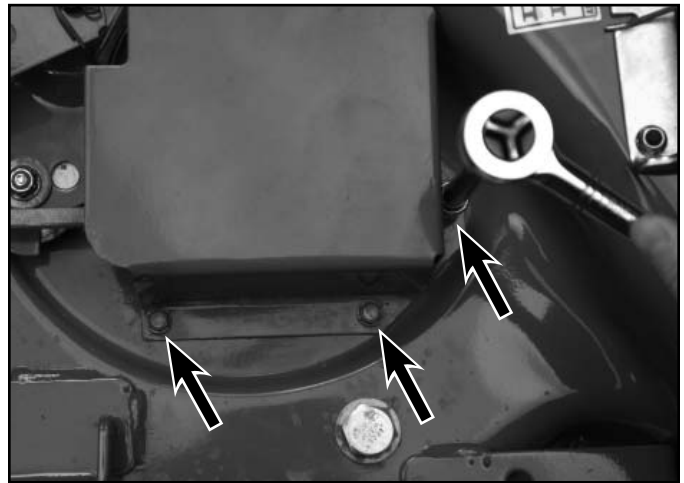

Fig 651

PICT-7852

# MOWER DECK

8. Remove the right mower deck belt cover (Fig. 652).



Fig 652

PICT-7853

10. Remove the lower idler pulley spring from the spring post on the mower deck (Fig. 654).

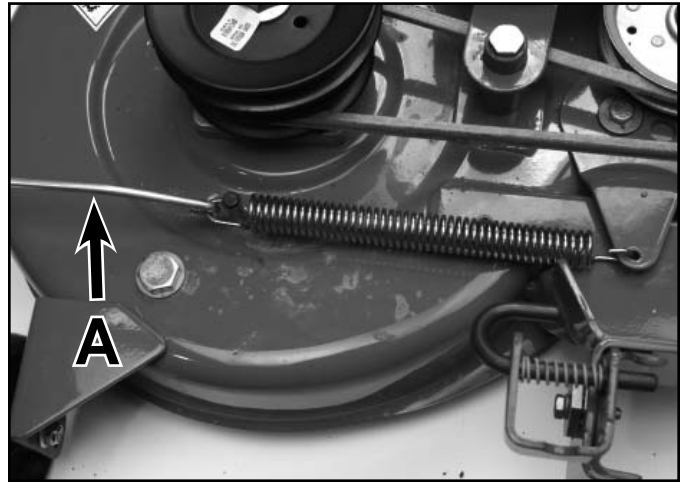

Fig 654

PICT-7855

9. Remove the upper idler pulley spring from the right side idler bracket screw (Fig. 653).



Fig 653

PICT-7854

- A. Spring removal tool (Toro P/N 92-5771)

11. Remove the nut and bolt securing the brake bracket to the idler pulley bracket (Fig. 655).

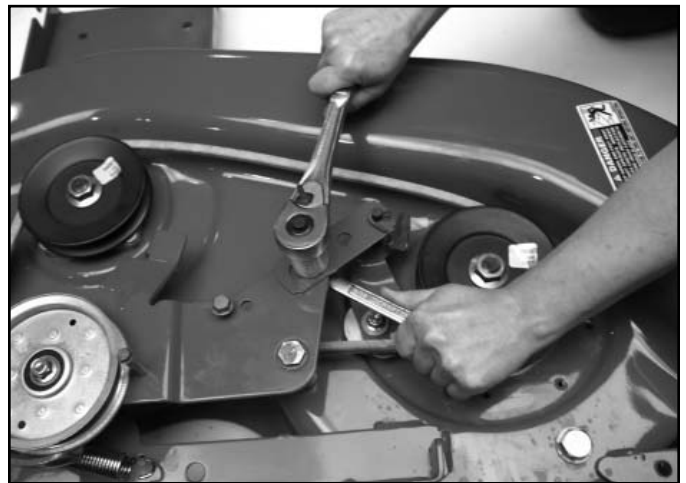

Fig 655

PICT-7858

# MOWER DECK

12. Remove the lower mower deck belt from the mower deck (Fig. 656).



Fig 656

PICT-7876

- B. Around the center spindle pulley; rotate the right idler assembly back and position the belt down between the idler assembly and brake bracket (Fig. 658).

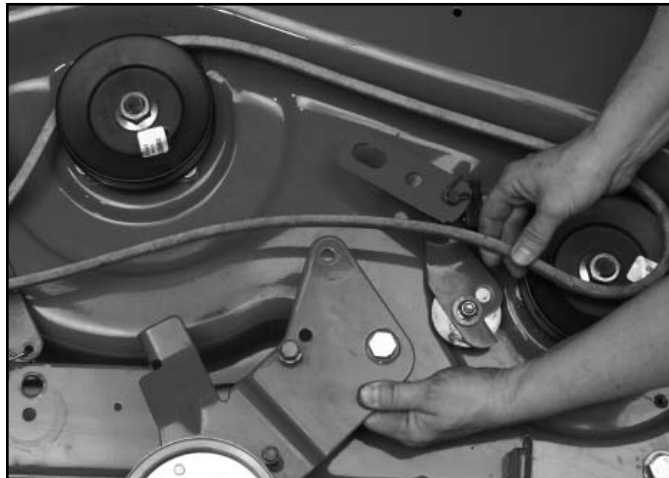

Fig 658

PICT-7879

## 46" Mower Deck - Lower Mower Deck Belt Replacement

### Installation

1. Route the lower mower deck belt as follows:

- A. Around the bottom pulley of the double pulley spindle assembly, to the inside of the left idler pulley (Fig. 657).

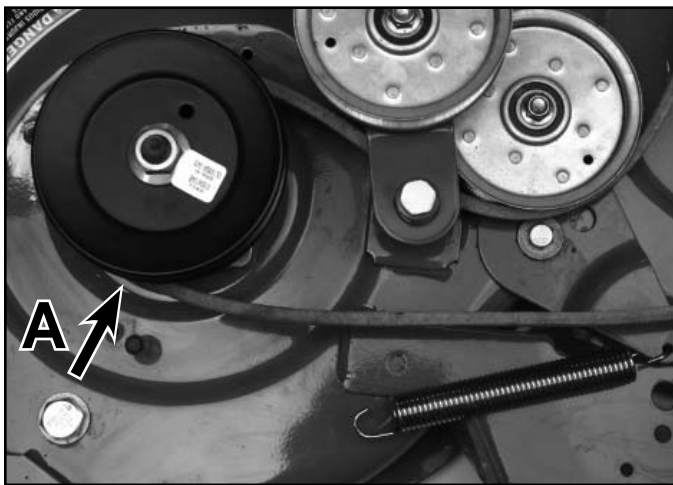

Fig 657

PICT-7878

- C. Rotate the right idler forward and position the belt behind the tab on the right idler bracket. Route the belt around the right spindle pulley (Fig. 659).



Fig 659

PICT-7880

7



# MOWER DECK

2. Position the brake bracket onto the idler bracket and insert the shoulder bolt (Fig. 660).



Fig 660

PICT-7881

4. Install the lower idler pulley spring onto the spring post on the mower deck (Fig. 662).

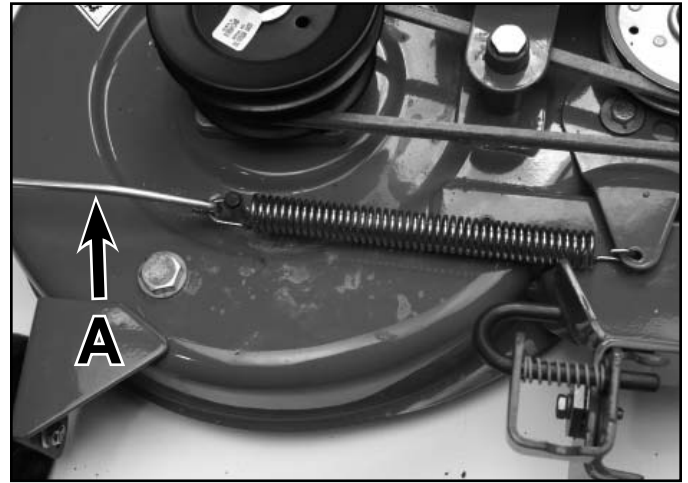

Fig 662

PICT-7855

3. Install a nut onto the shoulder bolt securing the brake bracket to the idler pulley bracket (Fig. 661).

**Note: The idler bracket and brake bracket should move freely.**

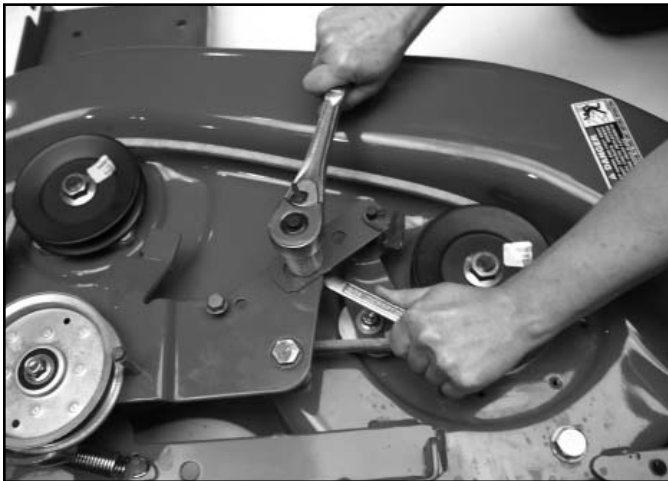

Fig 661

PICT-7858

5. Install the upper idler pulley spring to the spring post on the right side idler bracket (Fig. 663).

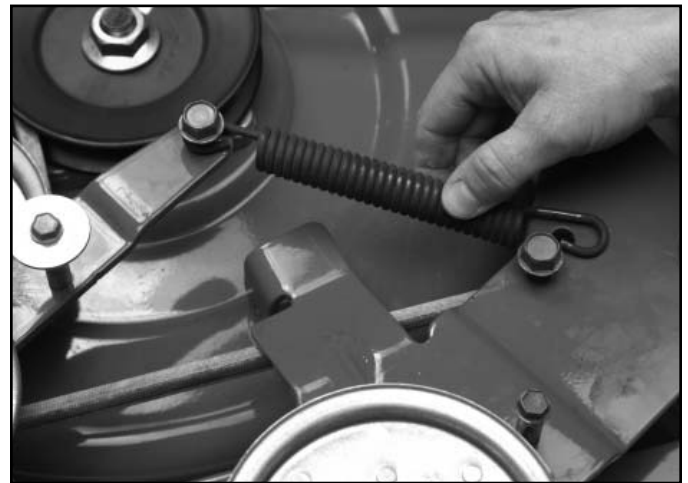

Fig 663

PICT-7854

# MOWER DECK

6. Position the right mower deck belt cover (Fig. 664).



Fig 664

PICT-7852

8. Install the return spring into the top hole on the right side mower deck belt cover and the brake bracket pin (Fig. 666).



Fig 666

PICT-7851

7. Install 3 self-tapping screws to secure the right mower deck cover to the mower deck (Fig. 665).

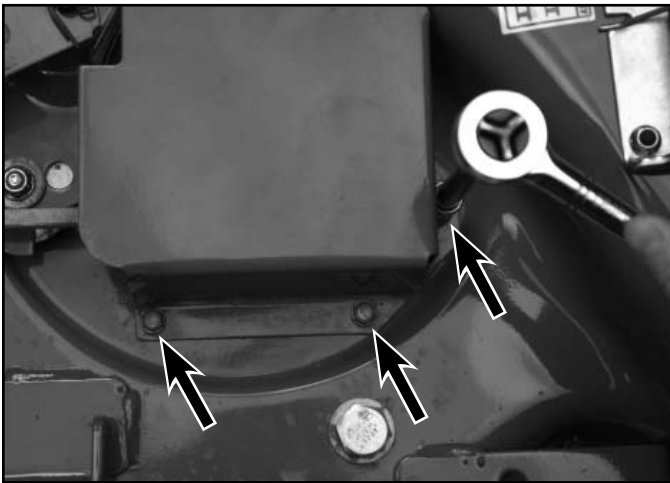

Fig 665

PICT-7852

9. Route the upper mower deck belt around the upper pulley of the double pulley spindle assembly. Tilt both idler pulleys and route the upper mower deck belt around the pulleys. Refer to the deck routing decal located on the mower deck (Fig. 667).



Fig 667

PICT-7883

7

# MOWER DECK

Mower deck belt routing decal (Fig. 668):

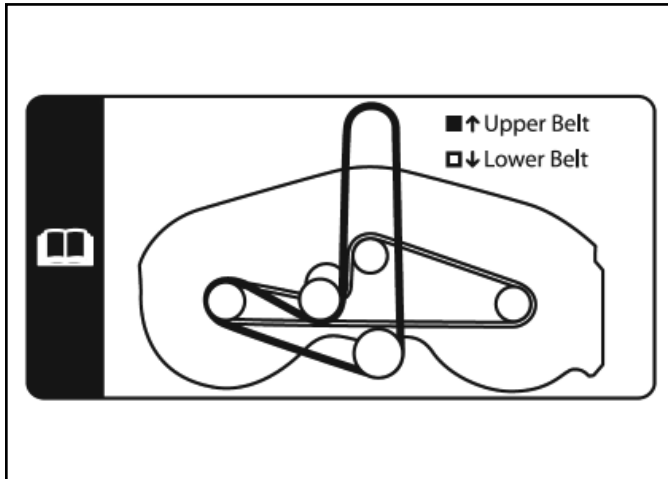

Fig 668 fig. LX460 112-1269

10. Tighten the nuts on the 2 upper idler pulley bolts (Fig. 669).

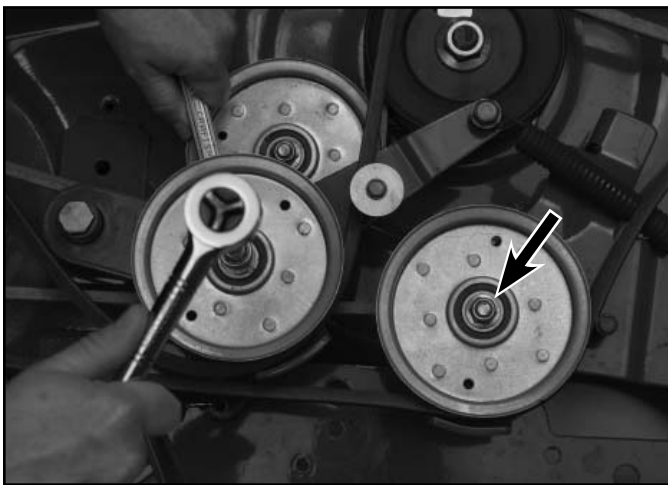

Fig 669 PICT-7840a

11. Position the left mower deck belt cover onto the mower deck (Fig. 670).



Fig 670 PICT-7839

12. Install 3 self-tapping screws to secure the left mower deck belt cover to the mower deck (Fig. 671).

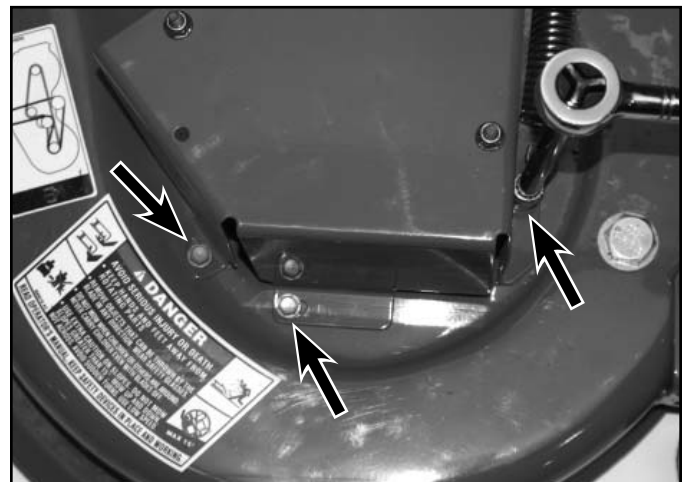

Fig 671 PICT-7835

13. Install the mower deck onto the tractor. Refer to "46" Mower Deck Installation" on page 7-72.

# MOWER DECK

## 46" Mower Deck - Upper Mower Deck Belt Replacement

### Removal

1. Remove the mower Deck from the tractor. Refer to "46" Mower Deck Removal" on page 7-69.
2. Remove the 3 self-tapping screws securing the left mower deck belt cover to the mower deck (Fig. 672).

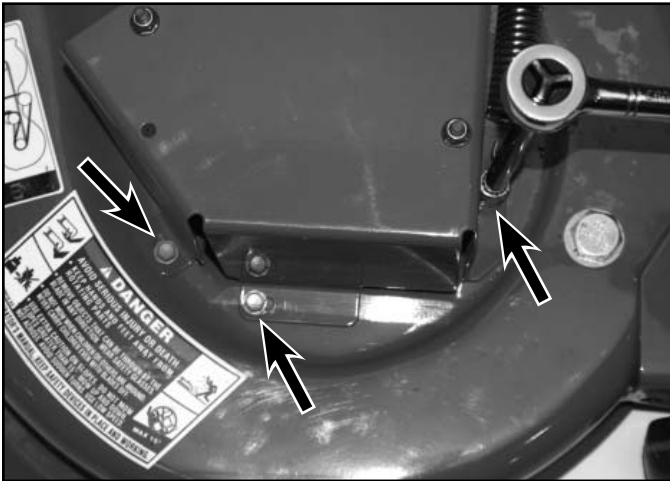

Fig 672

PICT-7835

3. Remove the mower deck belt cover from the mower deck (Fig. 673).



Fig 673

PICT-7839

4. Loosen the nuts on the 2 upper idler pulley bolts (Fig. 674).

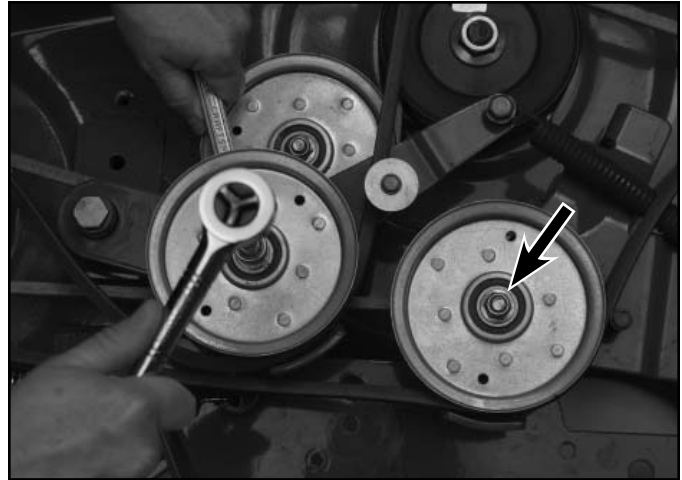

Fig 674

PICT-7840a

5. Tilt both idler pulleys and remove the upper mower deck belt from the mower deck (Fig. 675).

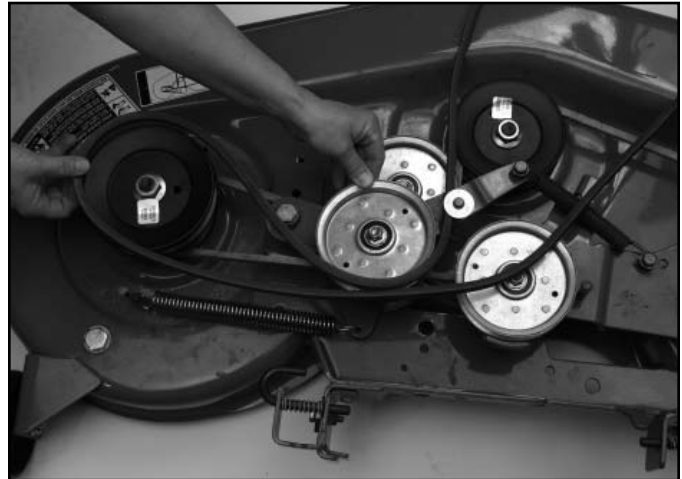

Fig 675

PICT-7842

## 46" Mower Deck - Upper Mower Deck Belt Replacement

### Installation

1. Tilt both idler pulleys and route the upper mower deck belt around the pulleys. Refer to the deck routing decal located on the mower deck (Fig. 676).

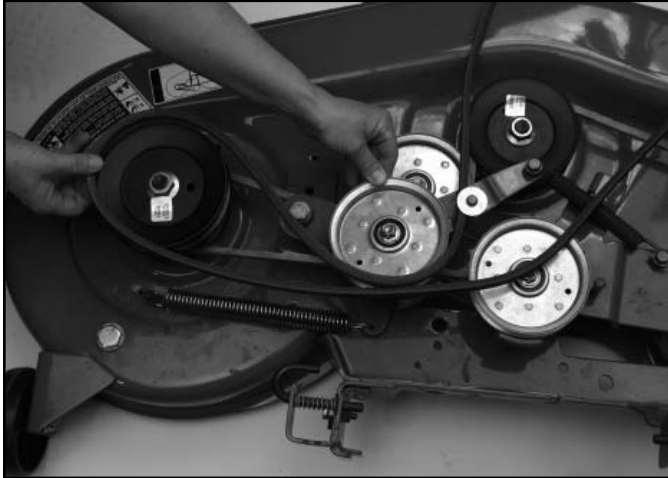

Fig 676

PICT-7842

Mower deck belt routing decal (Fig. 677):

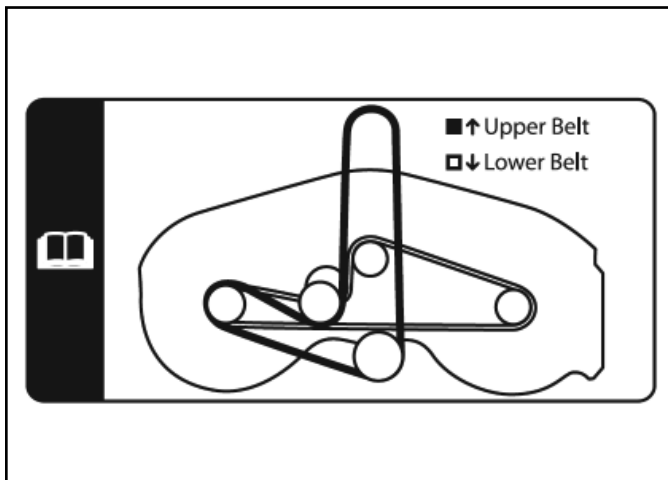

Fig 677

fig. LX460 112-1269

2. Tighten the nuts on the 2 upper idler pulley bolts (Fig. 678).

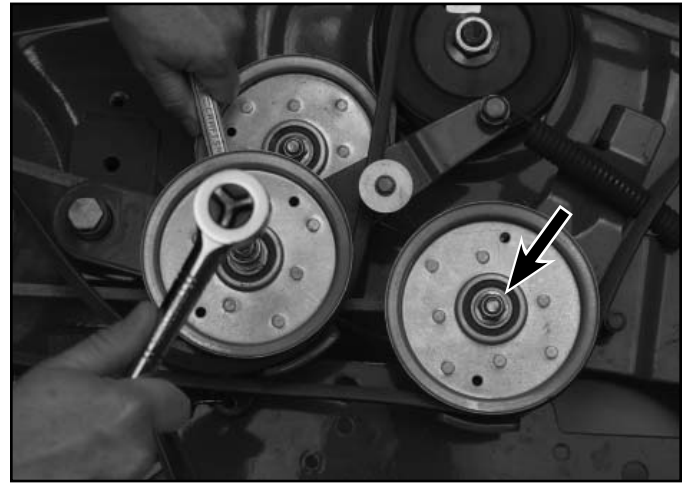

Fig 678

PICT-7840a

3. Position the left mower deck belt cover onto the mower deck (Fig. 679).



Fig 679

PICT-7839

# MOWER DECK

4. Install 3 self-tapping screws to secure the left mower deck belt cover to the mower deck (Fig. 680).

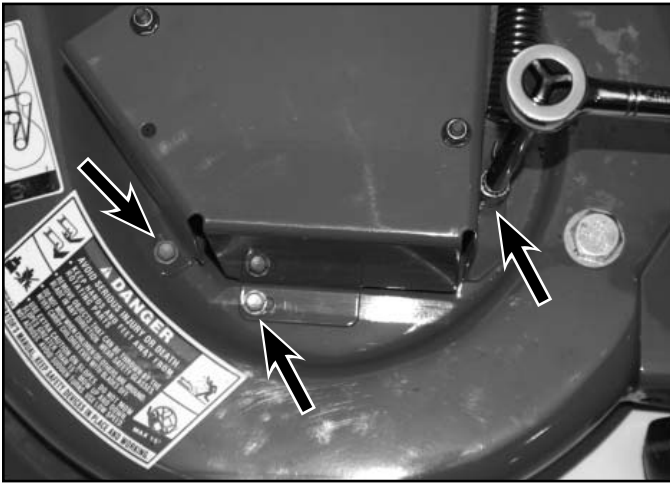

Fig 680

PICT-7835

2. Remove the 4 screws securing the right mower deck belt cover to the mower deck (Fig. 681).

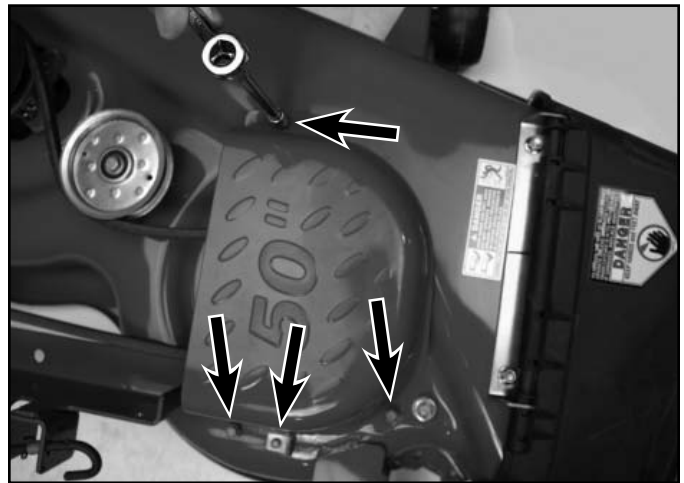

Fig 681

PICT-7918a

5. Install the mower deck onto the tractor. Refer to "46" Mower Deck Installation" on page 7-72.

3. Remove the right mower deck cover (Fig. 682).

## 50" Mower Deck - Belt Replacement

### Removal

1. Remove the mower deck from the tractor. Refer to "50" Mower Deck Removal" on page 7-74.



Fig 682

PICT-7919

# MOWER DECK

4. Remove the 3 screws securing the left mower deck belt cover to the mower deck (Fig. 683).



Fig 683

PICT-7920

6. Loosen the bolt and nut securing the idler pulley to the idler bracket (Fig. 685).

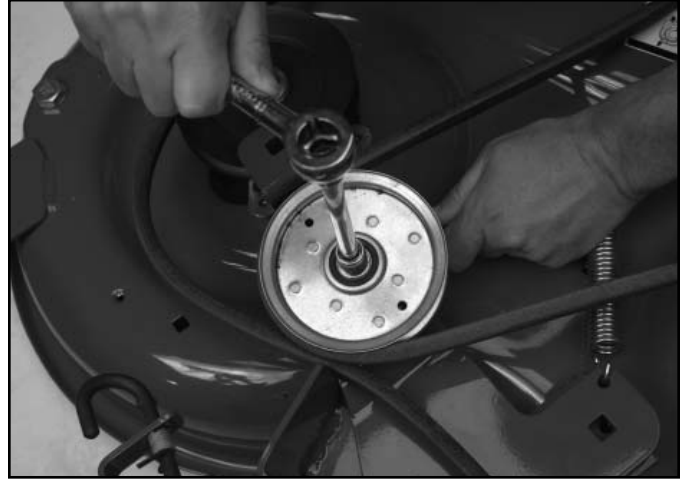

Fig 685

PICT-7923a

5. Remove the left mower deck cover (Fig. 684).

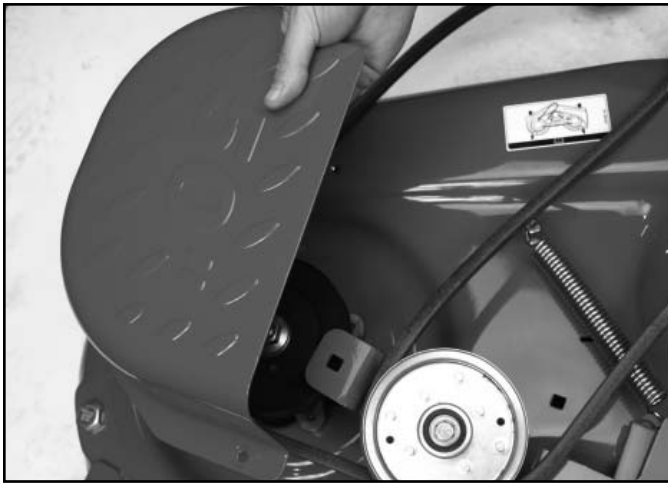

Fig 684

PICT-7921

7. Tilt the idler pulley and remove the belt from the mower deck (Fig. 686).



Fig 686

PICT-7922

7

# MOWER DECK

## 50" Mower Deck - Belt Replacement

### Installation

1. Tilt the idler pulley and route the belt around the idlers and pulleys. Refer to the belt routing decal on the mower deck (Fig. 687).

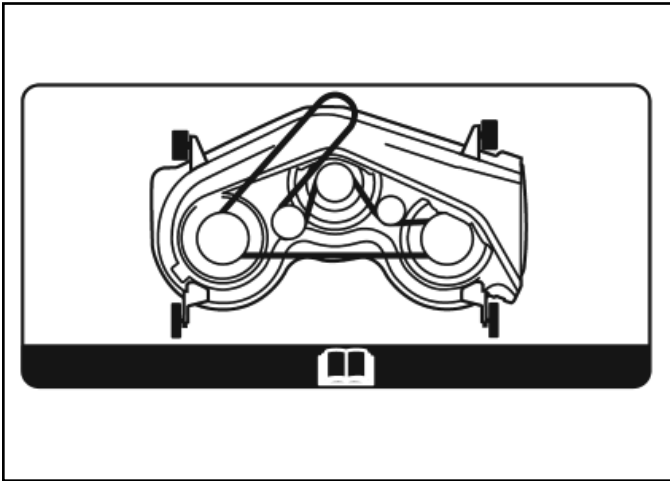

Fig 687

fig. 3 3354-973

2. Tighten the bolt and nut to secure the idler pulley to the idler bracket (Fig. 688).



Fig 688

PICT-7923a

3. Position the left mower deck cover on the mower deck (Fig. 689).

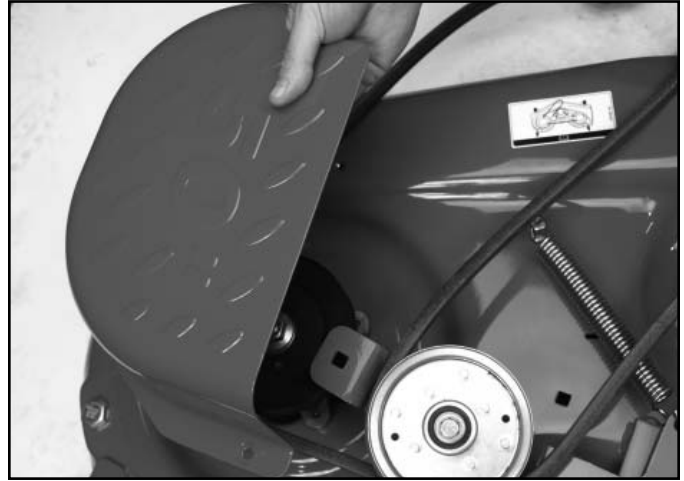

Fig 689

PICT-7921

4. Install 3 screws to secure the left mower deck belt cover to the mower deck (Fig. 690).



Fig 690

PICT-7920



# MOWER DECK

5. Position the right mower deck cover on the mower deck (Fig. 691).



Fig 691

PICT-7919

6. Install 4 screws to secure the right mower deck belt cover to the mower deck (Fig. 692).



Fig 692

PICT-7918

7. Install the mower deck onto the tractor. Refer to "50" Mower Deck Install" on page 7-76.

## 50" Mower Deck - Idler Replacement

### Removal

1. Remove the mower deck from the tractor. Refer to "50" Mower Deck Removal" on page 7-74.
2. Loosen the nut from the bolt securing the idler pulley to the idler bracket (Fig. 693).

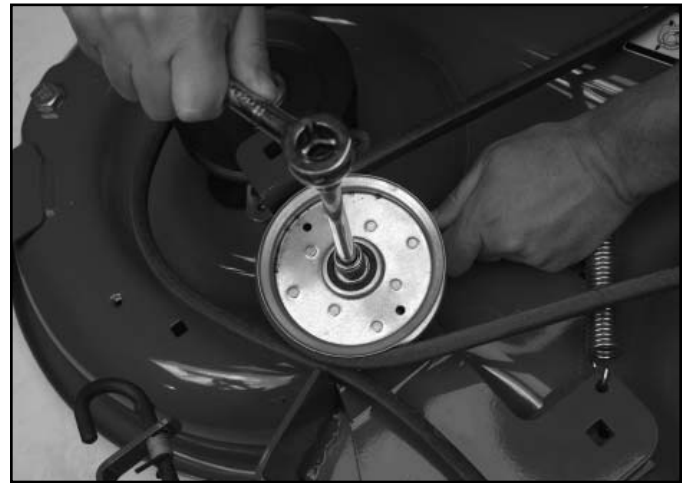

Fig 693

PICT-7923a

3. Tilt the idler pulley and remove the belt from around the idler pulley (Fig. 694).



Fig 694

PICT-7926

# MOWER DECK

4. Remove the idler spring from the spring post on the mower deck (Fig. 695).

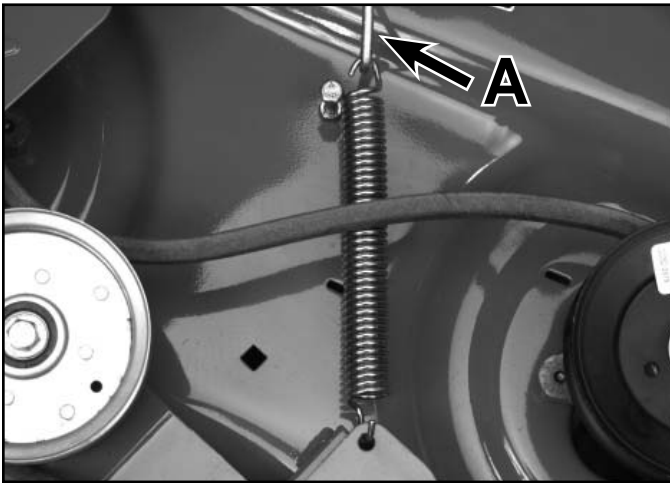

Fig 695

PICT-7927

6. Remove the shoulder bolt from the idler bracket assembly (Fig. 697).



Fig 697

PICT-7929

- A. Spring removal tool (Toro P/N 92-5771)

5. Remove the nut and Bellville washer from the shoulder bolt securing the idler bracket to the mower deck (Fig. 696).



Fig 696

PICT-7928

7. Remove the idler bracket assembly from the mower deck (Fig. 698).



Fig 698

PICT-7930

# MOWER DECK

8. Remove the washer (Fig. 699).



Fig 699

PICT-7931

2. Place the washer, grease side down, onto the mower deck aligning it with the shoulder bolt hole in the deck (Fig. 701).



Fig 701

PICT-7968

## 50" Mower Deck - Idler Replacement

### Installation

1. Apply grease to one side of the washer (Fig. 700).



Fig 700

PICT-7967

3. Install the shoulder bolt assembly into the idler bracket and position the idler bracket assembly onto the mower deck (Fig. 702).



Fig 702

PICT-7970a

# MOWER DECK

4. Install the Bellville washer (cup side up) and nut onto the shoulder bolt (Fig. 703).



Fig 703

PICT-7972

6. Install the idler spring onto the spring post on the mower deck (Fig. 705).

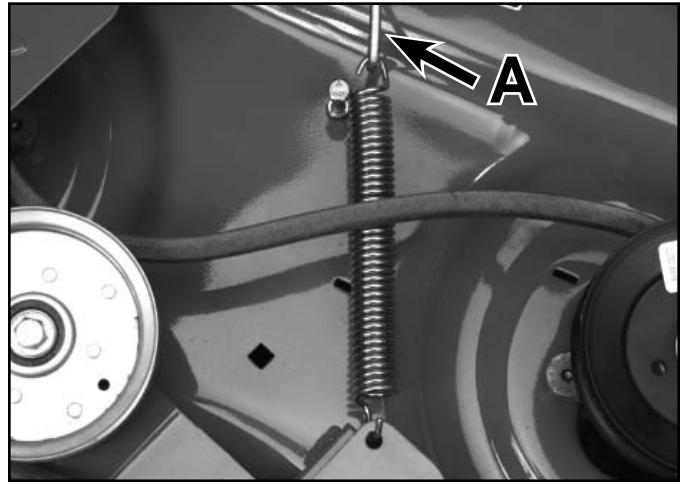

Fig 705

PICT-7927

5. Apply grease to the shoulder bolt (Fig. 704).



Fig 704

PICT-7973

- A. Spring removal tool (Toro P/N 92-5771)

7. Tilt the idler pulley and route the belt around the idler pulley. Refer to the belt routing decal (Fig. 706).

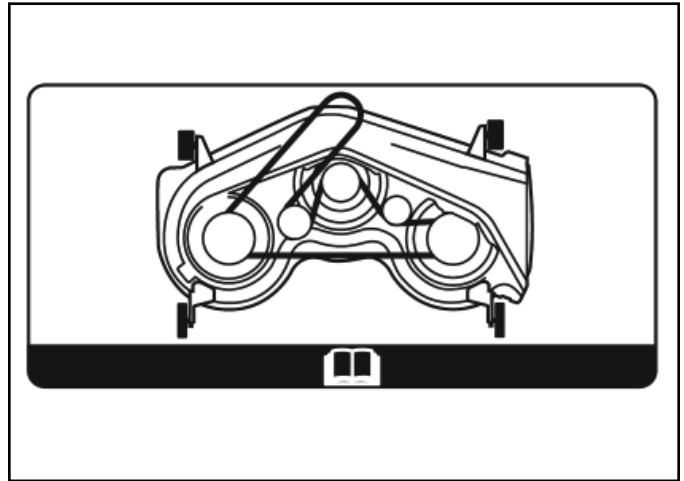

Fig 706

fig. 3 3354-973

# MOWER DECK

8. Tighten the bolt and nut to secure the idler pulley to the idler bracket (Fig. 707).



Fig 707

PICT-7923a

2. Remove the 3 screws securing the belt cover to the mower deck (Fig. 708).

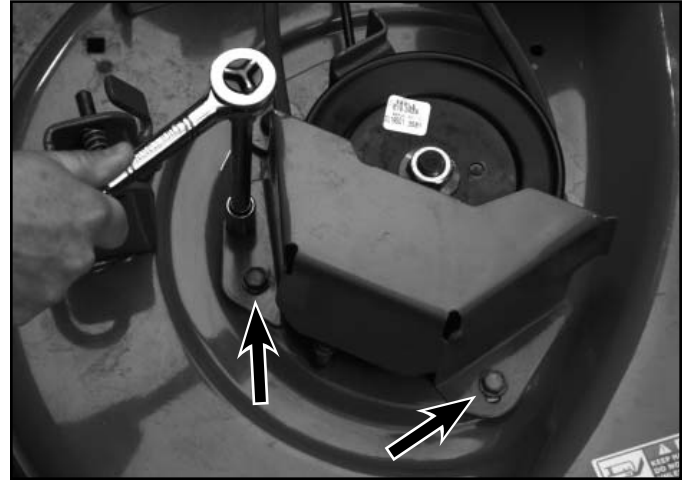

Fig 708

PICT-7711

9. Install the mower deck onto the tractor. Refer to "50" Mower Deck Installation" on page 7-76.

## 42" Mower Deck - Spindle Replacement

### Removal

1. Remove the mower deck. Refer to "42" Mower Deck Removal" on page 7-64.

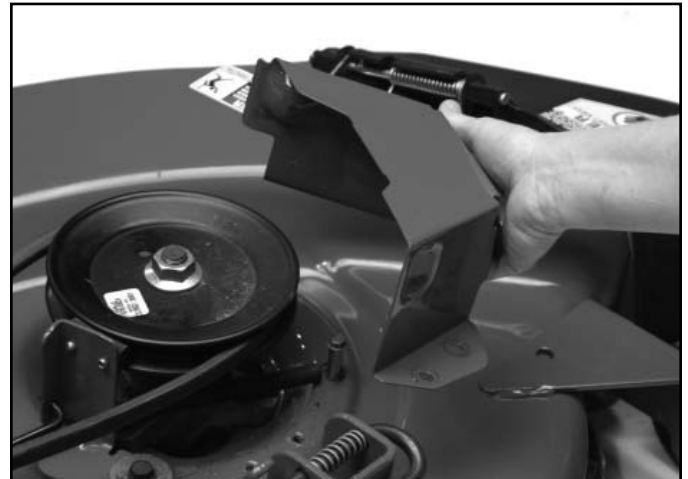

Fig 709

PICT-7712

# MOWER DECK

4. Remove the belt from the spindle pulley (Fig. 710).

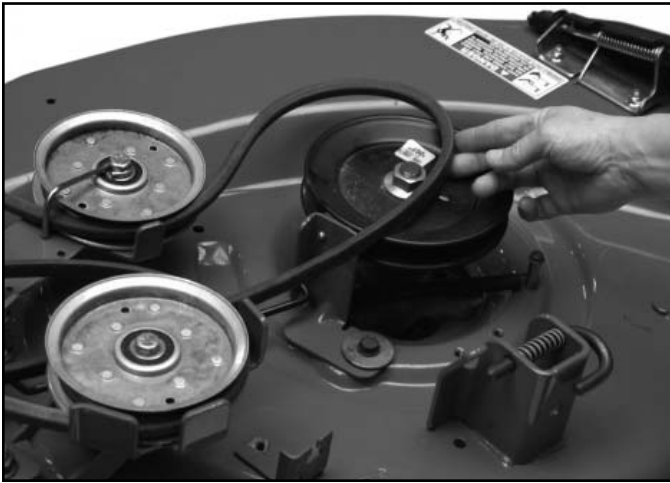

Fig 710

PICT-7713

8. Lift or turn the mower deck over to access the underside.

9. Block the blade and remove the nut from the mower deck spindle assembly (Fig. 712).



Fig 712

PICT-7716

7. Remove the deck brake assembly spring (Fig. 711).

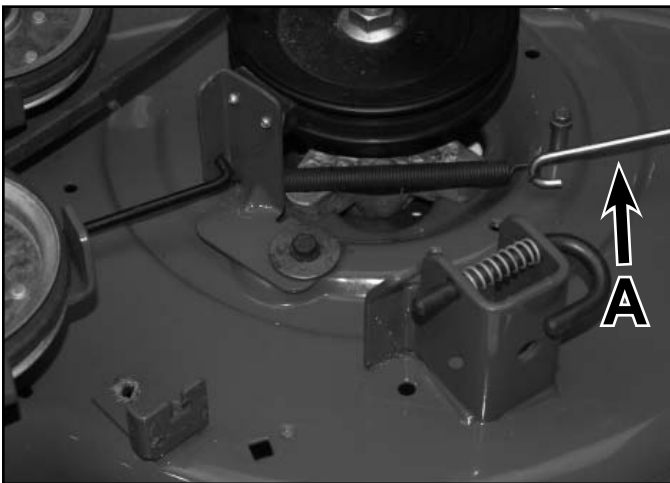

Fig 711

PICT-7715

- A. Spring removal tool (Toro P/N 92-5771)



Fig 713

PICT-7717

# MOWER DECK

11. Remove the 4 self-tapping screws securing the spindle housing to the mower deck (Fig. 714).



Fig 714

PICT-7718

12. Lift the mower deck and remove the mower deck spindle (Fig. 715).



Fig 715

PICT-7722

## 42" Mower Deck - Spindle Replacement

### Installation

1. Lift the mower deck and position the spindle assembly to the mower deck opening (Fig. 716).



Fig 716

PICT-7755

**Note:** Ensure the deck brake is positioned in the groove of the pulley.

2. Install 4 self-tapping screws securing the spindle housing to the mower deck. Torque each screw to 16.7 to 33.3 ft-lbs. (23 to 45 Nm) (Fig. 717).



Fig 717

PICT-7718

# MOWER DECK

3. Position the mower blade onto the spindle shaft (Fig. 718).



Fig 718

PICT-7717

4. Block the blade and install a nut onto the mower deck spindle assembly. Torque the nut to 70-90 ft-lbs. (94.9-122 Nm) (Fig. 719).



Fig 719

PICT-7716

5. Turn the mower deck right side up.
6. Hook the mower deck brake assembly spring to the deck brake assembly bracket and the spring stud on the mower deck (Fig. 720).



Fig 720

PICT-7757

7. Route the belt around the mower deck spindle pulley (Fig. 721).

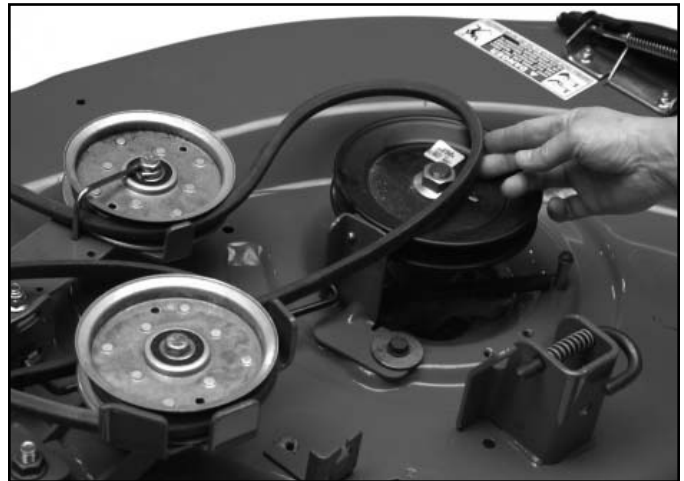

Fig 721

PICT-7713

7



# MOWER DECK

8. Position the belt cover onto the mower deck (Fig. 722).

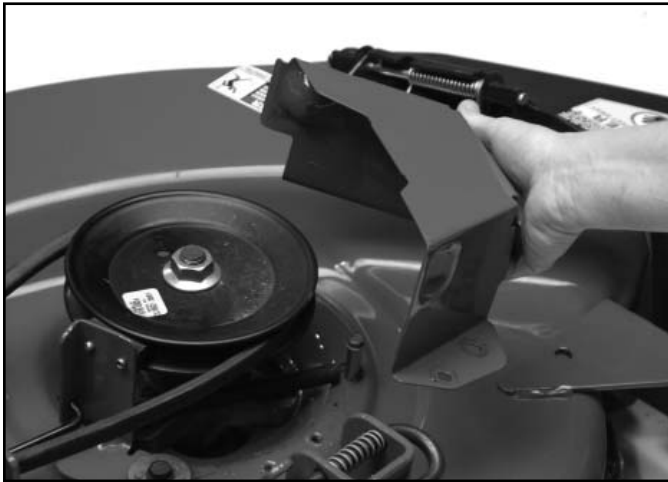

Fig 722

PICT-7712

9. Install 3 screws securing the belt cover to the mower deck (Fig. 723).

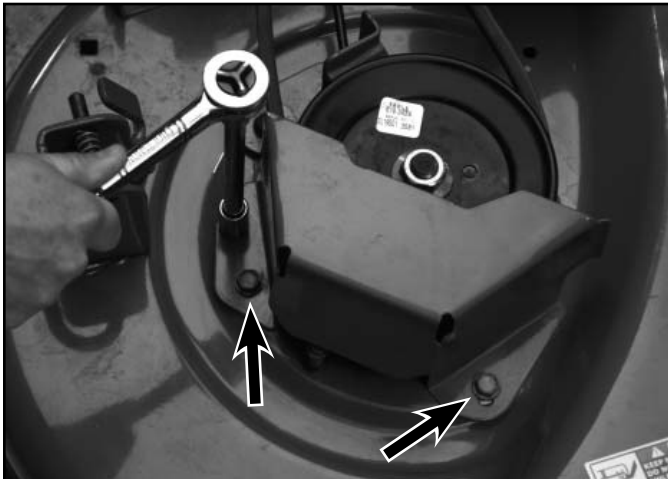

Fig 723

PICT-7711

10. Install the mower deck. Refer to "42" Mower Deck Installation" on page 7-67.

## 42" Mower Deck - Spindle Service

1. Secure the mower deck spindle into a vise.
2. Secure the pulley and remove the nut securing the pulley to the mower deck spindle (Fig. 724).



Fig 724

PICT-7733a

3. Remove the pulley from the spindle shaft (Fig. 725).



Fig 725

PICT-7751

# MOWER DECK

4. Remove the spacer from the spindle shaft (Fig. 726).



Fig 726

PICT-7735a

7. Remove the bearing and 2 spacers from the pulley side of the housing (Fig. 728).



Fig 728

PICT-7742a

5. Remove the spindle from the vise.
6. Remove the spindle shaft assembly from the spindle housing (Fig. 727).



Fig 727

PICT-7738a

8. Press the second bearing out of the blade side of the housing (Fig. 729).

**Note: Since this bearing is staked in place it WILL be damaged if removed.**



Fig 729

PICT-7745a

7

# MOWER DECK

9. Inspect the bearings and spacers and replace if worn or damaged.
10. Press the blade side bearing into the housing (Fig. 730).



Fig 730

PICT-7740

11. Secure the housing assembly into a vise and stake the bearing (Fig. 731).



Fig 731

PICT-7748a

12. Insert 2 spacers into the spindle housing (Fig. 732).



Fig 732

PICT-7749

13. Install a bearing into the pulley side of the spindle housing (Fig. 733).



Fig 733

PICT-7750

7

# MOWER DECK

14. Insert the spindle shaft into the housing assembly (Fig. 734).

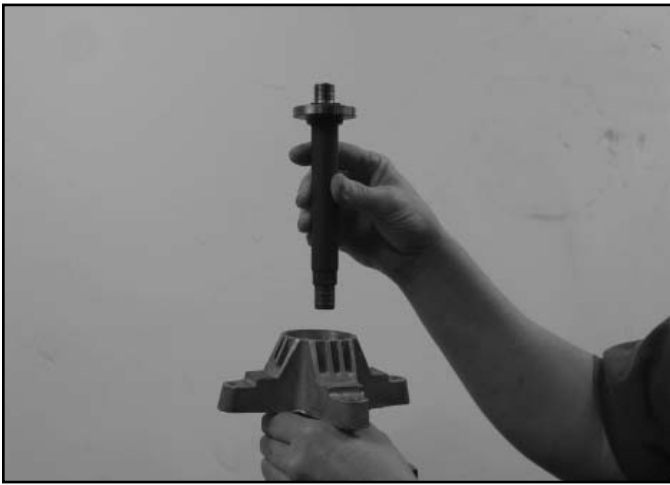

Fig 734

PICT-7738a

17. Position the pulley onto the spindle shaft (Fig. 736).



Fig 736

PICT-7752

15. Secure the housing in a vise.

16. Place a spacer onto the spindle shaft (Fig. 735).



Fig 735

PICT-7735a

18. Secure the pulley and install the nut onto the spindle shaft (Fig. 737).



Fig 737

PICT-7733

7

## 46" Mower Deck - Double Pulley Spindle Service

1. Secure the mower deck spindle into a vise.
2. Secure the spindle shaft and remove the nut securing the pulley to the mower deck spindle (Fig. 738).



Fig 738

PICT-7991

3. Remove the upper pulley (Fig. 739).



Fig 739

PICT-7993a

4. Remove the washer (Fig. 740).



Fig 740

PICT-7994a

5. Remove the spacer (Fig. 741).



Fig 741

PICT-7997a

# MOWER DECK

6. Remove the lower pulley (Fig. 742).

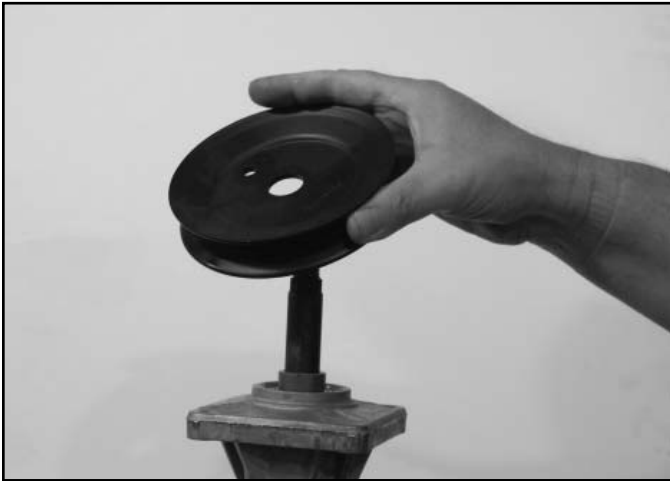

Fig 742

PICT-7998a

8. Remove the spindle from the vise.  
9. Remove the spindle shaft and shoulder bearing assembly from the spindle housing (Fig. 744).



Fig 744

PICT-8000a

7. Remove the lower spacer from the spindle shaft (Fig. 743).



Fig 743

PICT-7999a

10. Remove the shoulder bearing from the spindle shaft (Fig. 745).



Fig 745

PICT-8001a

7

# MOWER DECK

11. Remove the bearing and spacer from the blade side of the housing (Fig. 746).

**Note:** Since this bearing is staked in place it **WILL** be damaged if removed.

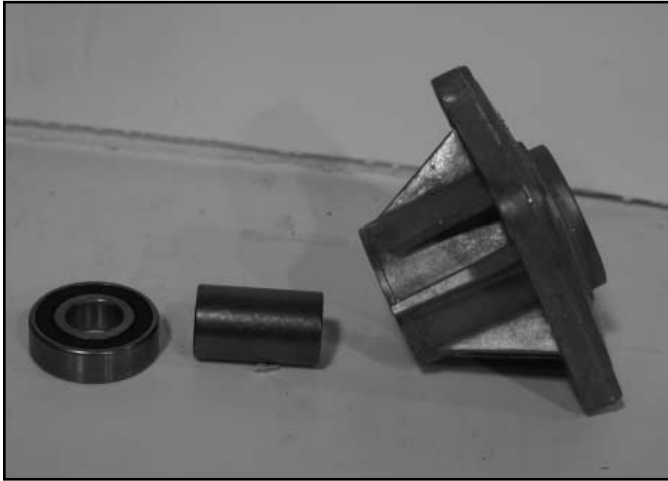

Fig 746

PICT-8004

13. Inspect the bearings and spacers and replace if worn or damaged.

14. Press the blade side bearing into the housing (Fig. 748).



Fig 748

PICT-8008

12. Remove the second bearing from the pulley side of the housing (Fig. 747).



Fig 747

PICT-8005

15. Secure the housing assembly into a vise and stake the bearing (Fig. 749).



Fig 749

PICT-8011a

7

# MOWER DECK

16. Insert the spacer and install a bearing into the pulley side of the spindle housing (Fig. 750).



Fig 750

PICT-8007

18. Install the spindle shaft and shoulder bearing assembly into the spindle housing (Fig. 752).



Fig 752

PICT-8000a

17. Slide the shoulder bearing onto the spindle shaft (Fig. 751).



Fig 751

PICT-8001a

19. Place the spindle housing into a vise.

20. Install the lower spacer onto the spindle shaft (Fig. 753).



Fig 753

PICT-7999a

7



# MOWER DECK

21. Install the lower pulley (Fig. 754).



Fig 754

PICT-7998a

23. Install a washer (Fig. 756).



Fig 756

PICT-7994a

22. Install the spacer onto the spindle shaft (Fig. 755).



Fig 755

PICT-7997a

24. Install the upper pulley (Fig. 757).



Fig 757

PICT-7993a

7

# MOWER DECK

25. Secure the spindle shaft and install a nut to secure the pulleys to the mower deck spindle (Fig. 758).



Fig 758

PICT-7991

3. Remove the pulley (Fig. 760).



Fig 760

PICT-8014

26. Remove the mower deck spindle from the vise.

## 46" Mower Deck - Single Pulley Spindle Service

1. Secure the mower deck spindle into a vise.
2. Secure the spindle shaft and remove the nut securing the pulley to the mower deck spindle (Fig. 759).



Fig 759

PICT-8012a

4. Remove the spacer (Fig. 761).



Fig 761

PICT-8015

7

# MOWER DECK

5. Remove the spindle from the vise.
6. Remove the spindle shaft and shoulder bearing assembly from the spindle housing (Fig. 762).



Fig 762

PICT-8000a

8. Remove the bearing and spacer from the blade side of the housing (Fig. 764).

**Note: Since this bearing is staked in place it WILL be damaged if removed.**

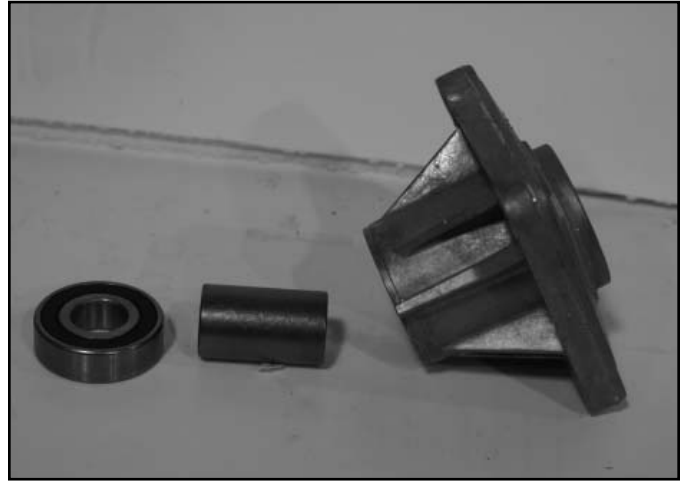

Fig 764

PICT-8004

7. Remove the shoulder bearing from the spindle shaft (Fig. 763).



Fig 763

PICT-8001a

9. Remove the second bearing from the pulley side of the housing (Fig. 765).

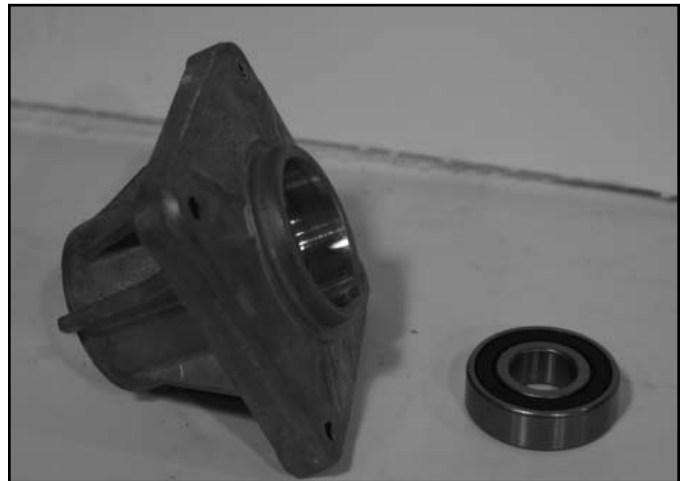

Fig 765

PICT-8005

# MOWER DECK

10. Inspect the bearings and spacers and replace if worn or damaged.
11. Press the blade side bearing into the housing (Fig. 766).



Fig 766

PICT-8008

13. Insert the spacer and install a bearing into the pulley side of the spindle housing (Fig. 768).



Fig 768

PICT-8007

12. Secure the housing assembly into a vise and stake the bearing (Fig. 767).



Fig 767

PICT-8011a

14. Install the shoulder bearing onto the spindle shaft (Fig. 769).



Fig 769

PICT-8001a

7

# MOWER DECK

15. Install the spindle shaft and shoulder bearing assembly into the spindle housing (Fig. 770).



Fig 770

PICT-8000a

18. Install the pulley (Fig. 772).



Fig 772

PICT-8014

16. Place the spindle housing into a vise.

17. Install the spacer onto the spindle shaft (Fig. 771).



Fig 771

PICT-8015

19. Secure the spindle shaft and install a nut to secure the pulley to the mower deck spindle (Fig. 773).



Fig 773

PICT-8012a

20. Remove the mower deck spindle from the vise.

# MOWER DECK

## 50" Mower Deck - Spindle Service

1. Secure the mower deck spindle into a vise.
2. Secure the spindle shaft and remove the nut securing the pulley to the mower deck spindle (Fig. 774).



Fig 774

PICT-8046a

3. Remove the washer (Fig. 775).



Fig 775

PICT-8047a

4. Remove the pulley (Fig. 776).



Fig 776

PICT-8048a

5. Remove the spindle/shoulder bearing assembly from the spindle housing (Fig. 777).



Fig 777

PICT-8049a

# MOWER DECK

6. Remove the shoulder spacer from the spindle shaft (Fig. 778).



Fig 778

PICT-8050a

7. Remove the bearing and 2 spacers from the pulley side of the housing (Fig. 779).



Fig 779

PICT-7742a

8. Press the second bearing out of the blade side of the housing (Fig. 780).

**Note:** Since this bearing is staked in place it **WILL** be damaged if removed.

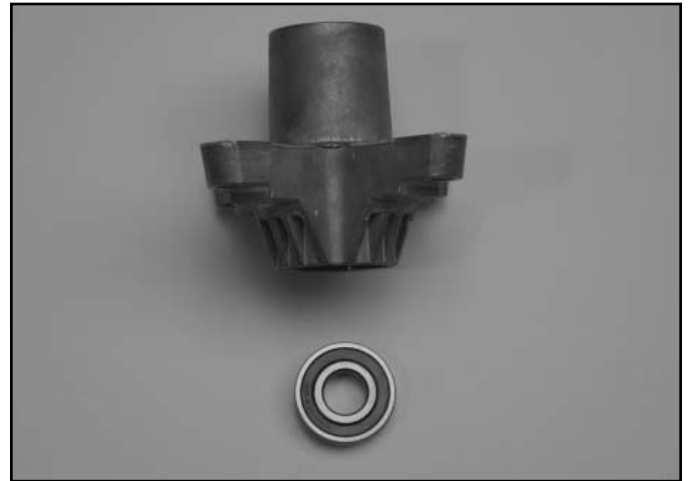

Fig 780

PICT-7745a

9. Inspect the bearings and spacers and replace if worn or damaged.

10. Press the blade side bearing into the housing (Fig. 781).



Fig 781

PICT-7740

# MOWER DECK

11. Secure the housing assembly into a vise and stake the bearing (Fig. 782).



Fig 782

PICT-7748a

13. Install a bearing into the pulley side of the spindle housing (Fig. 784).



Fig 784

PICT-7750

12. Insert 2 spacers into the spindle housing (Fig. 783).



Fig 783

PICT-7749

14. Install a shoulder spacer onto the spindle shaft (Fig. 785).



Fig 785

PICT-8050a

7



# MOWER DECK

15. Install the spindle shaft and shoulder spacer assembly into the spindle housing (Fig. 786).



Fig 786

PICT-8049a

18. Install a washer onto the spindle shaft (Fig. 788).



Fig 788

PICT-8047a

16. Place the spindle housing into a vise.

17. Install the pulley (Fig. 787).



Fig 787

PICT-8048a

19. Secure the spindle shaft and install a nut to secure the pulley to the mower deck spindle (Fig. 789).

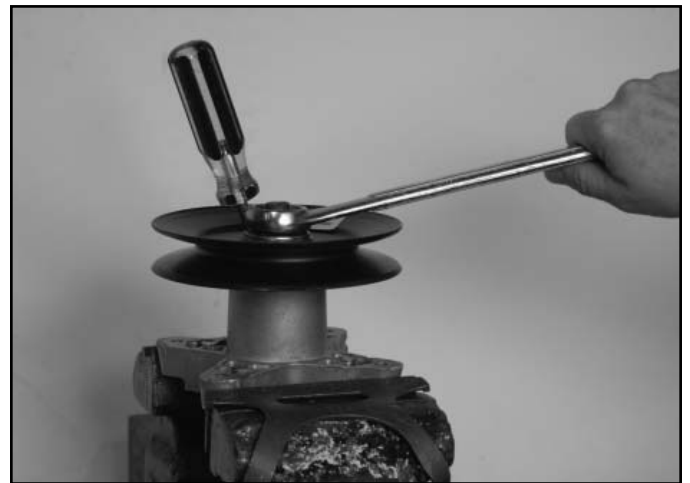

Fig 789

PICT-8046

20. Remove the mower deck spindle from the vise.

# MOWER DECK

## 42" Mower Deck Removal

1. Lower the lift lever to the lowest height-of-cut setting (Fig. 790).



Fig 790

PICT-9664

2. Loosen the self-tapping screw securing the belt retainer rod to the frame, located to the left side of the engine drive pulley (Fig. 791).

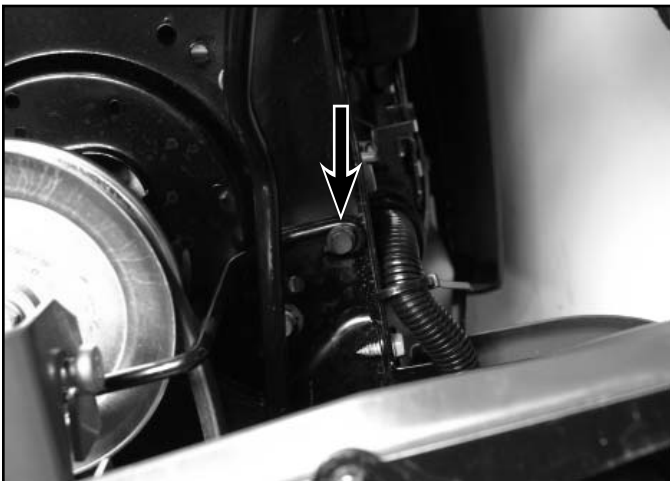

Fig 791

PICT-9668

3. Push the PTO idler pulley and bracket towards the rear of the machine (Fig. 792).



Fig 792

PICT-9673

4. Remove the mower deck belt from the lower engine pulley (Fig. 793).

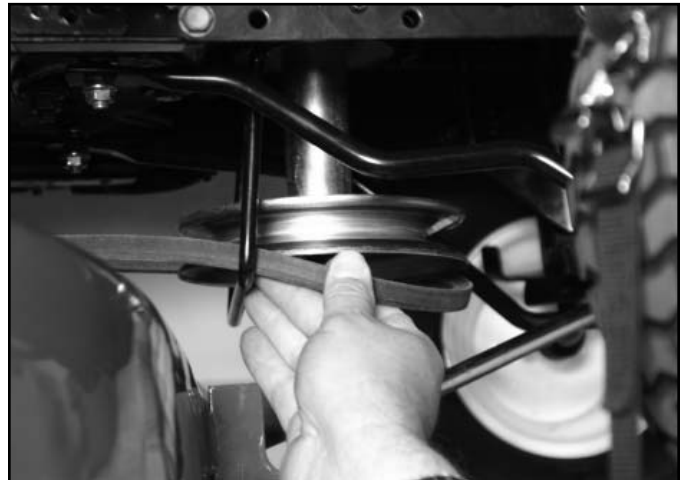

Fig 793

PICT-9675

# MOWER DECK

5. Remove the hairpin cotter from the deck engagement cable located on the rear of the mower deck (Fig. 794).



Fig 794

PICT-9677

7. Unhook the deck engagement spring from the idler bracket (Fig. 796).

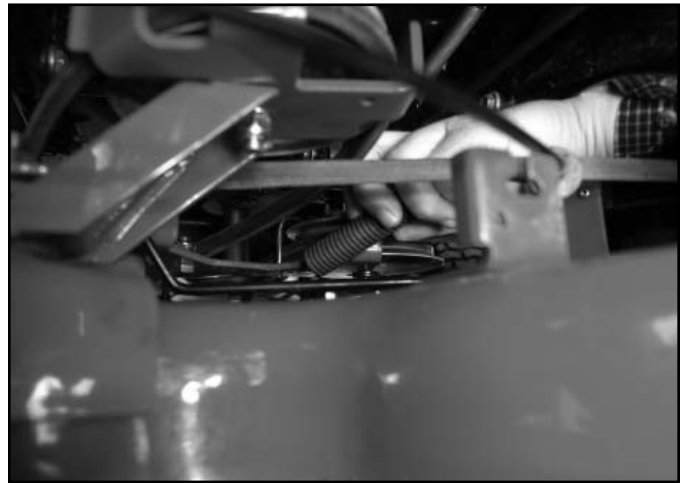

Fig 796

PICT-9678

6. Remove the deck engagement cable from the mower deck (Fig. 795).



Fig 795

PICT-9679

8. Pull the rear deck support pins outward from the deck lift arms located on the right and left sides (Fig. 797).



Fig 797

PICT-9676

# MOWER DECK

9. Raise the lift lever to the highest height-of-cut setting (Fig. 798).



Fig 798

PICT-9680

11. Remove the front adjustment deck rod from the tractor before the tractor is moved (Fig. 800).



Fig 800

PICT-9683

10. Slide the mower deck forward and release the front adjustment deck rod from the front deck hanger bracket (Fig. 799).

**Note:** Carefully lower the mower deck to the ground.



Fig 799

PICT-9681

12. Slide the mower deck out from under the right side of the tractor. (Fig. 801).

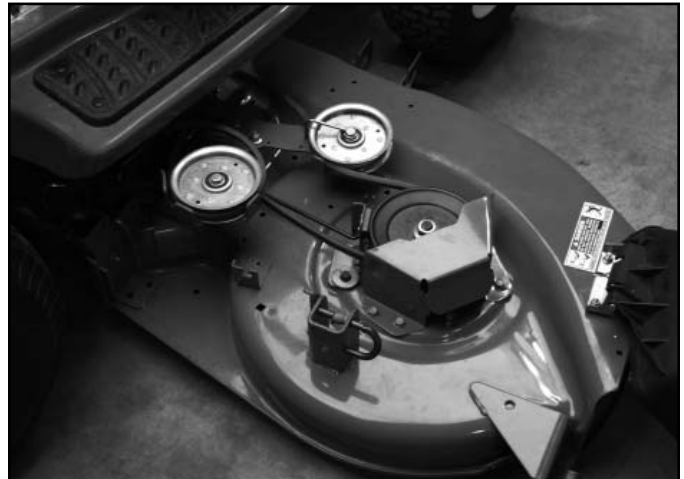

Fig 801

PICT-9684

7

## 42" Mower Deck Installation

1. Slide the mower deck under the tractor so the side discharge chute is on the right side of the tractor (Fig. 802).



Fig 802

PICT-9684

2. Hook the deck engagement spring to the idler bracket (Fig. 803).



Fig 803

PICT-9678

3. Install the deck engagement cable into the bracket on the rear of the mower deck (Fig. 804).



Fig 804

PICT-9679

4. Install the front adjustment deck rod into the hanger plate (Fig. 805).



Fig 805

PICT-9683

# MOWER DECK

5. Place blocks under the mower deck to raise it up.
6. Slide the front adjustment deck rod into the deck hanger bracket on the front of the mower deck (Fig. 806).



Fig 806

PICT-9681

8. Slide the mower deck toward the rear of the tractor so the deck pins line up with the deck lift arms.
9. Pull the rear right and left deck support pins outward and position the rear deck hanger bracket holes inline with the pins. Release the pins to secure the rear of the mower deck (Fig. 808).



Fig 808

PICT-9676

7. Lower the lift lever to the lowest height-of-cut setting (Fig. 807).



Fig 807

PICT-9664

10. Push the PTO idler pulley and bracket towards the rear of the machine (Fig. 809).



Fig 809

PICT-9673

# MOWER DECK

11. Install the mower deck belt around the lower engine pulley (Fig. 810).

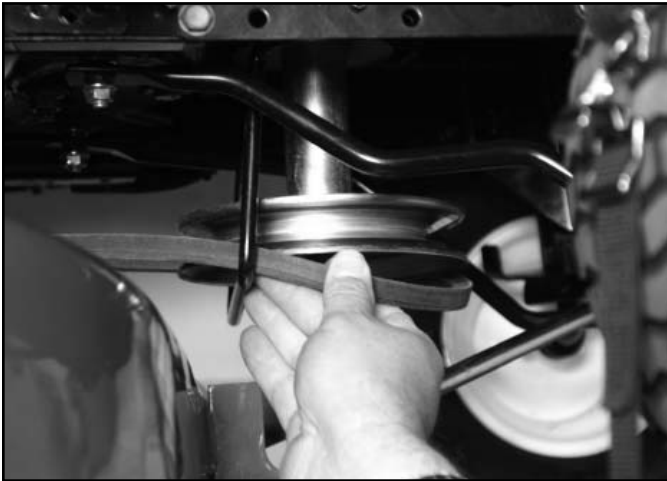

Fig 810

PICT-9675

13. Raise the lift lever to the highest height-of-cut setting (Fig. 812).



Fig 812

PICT-9680

12. Tighten the self-tapping screw to secure the belt retainer rod to the frame (Fig. 811).

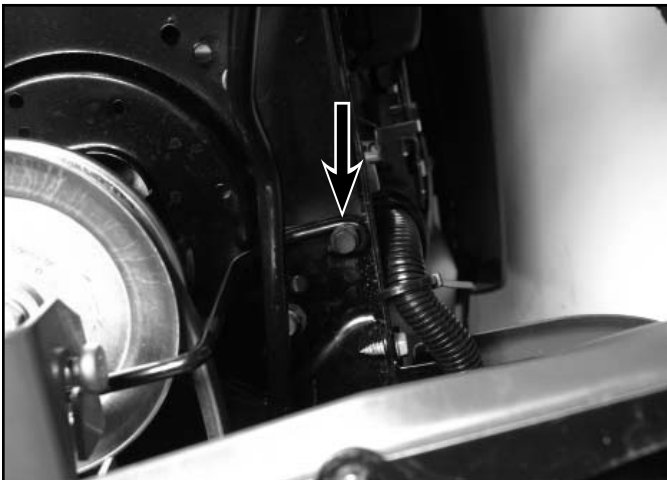

Fig 811

PICT-9668

## 46" Mower Deck Removal

1. Lower the lift lever to the lowest height-of-cut setting (Fig. 813).



Fig 813

PICT-9701

# MOWER DECK

2. Remove the mower deck belt from the lower engine pulley (Fig. 814).



Fig 814

PICT-9704

4. Remove the deck engagement cable from the mower deck (Fig. 816).



Fig 816

PICT-9709

3. Remove the hairpin cotter from the deck engagement cable located on the rear of the mower deck (Fig. 815).

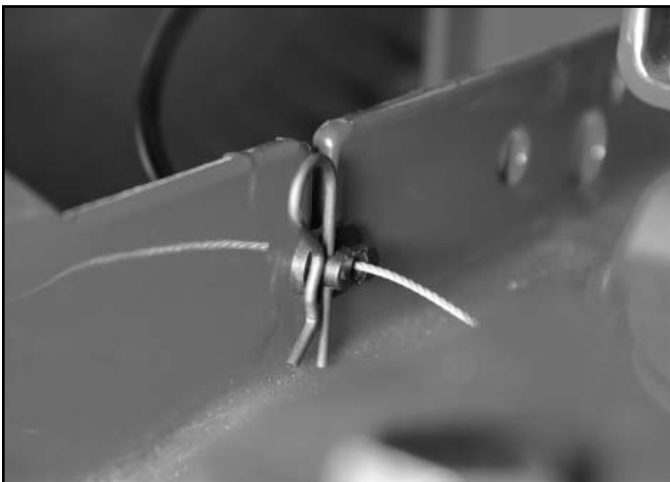

Fig 815

PICT-9706

5. Unhook the deck engagement spring from the idler bracket (Fig. 817).



Fig 817

PICT-9710

7



# MOWER DECK

6. Pull the rear deck support pins outward from the deck lift arms (Fig. 818).



Fig 818

PICT-9713

7. Raise the lift lever to the highest height-of-cut setting (Fig. 819).



Fig 819

PICT-9717

8. Slide the mower deck forward and release the front adjustment deck rod from the front deck hanger bracket (Fig. 820).

**Note:** Carefully lower the mower deck to the ground.

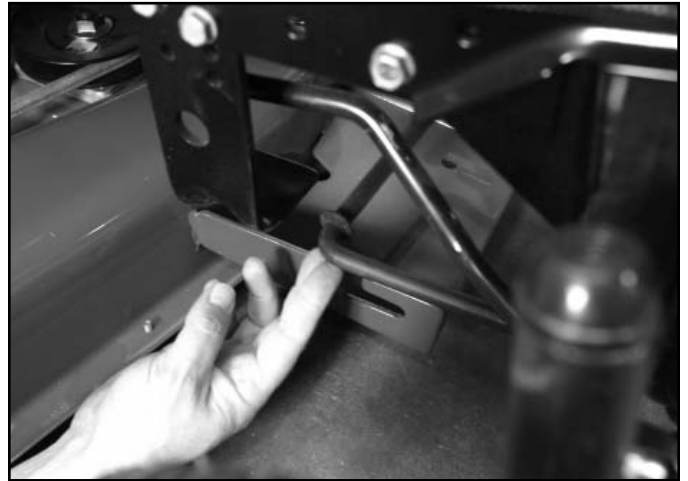

Fig 820

PICT-9715

9. Slide the mower deck out from under the right side of the tractor. (Fig. 821).



Fig 821

PICT-9718

# MOWER DECK

## 46" Mower Deck Installation

1. Slide the mower deck under the tractor so the side discharge chute is on the right side of the tractor (Fig. 822).



Fig 822

PICT-9718

2. Hook the deck engagement spring to the idler bracket (Fig. 823).

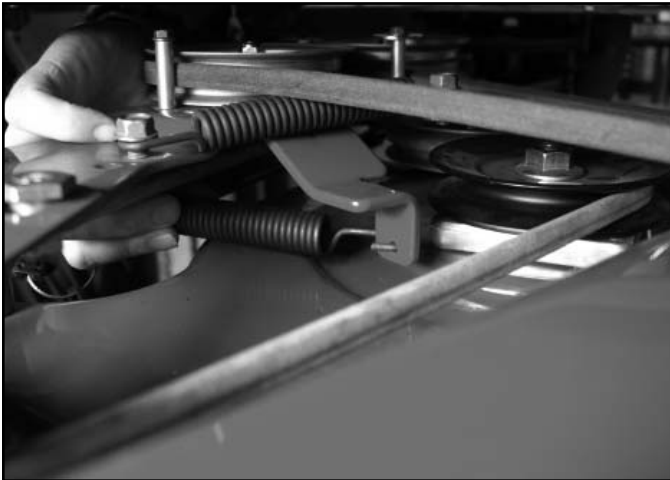

Fig 823

PICT-9710

3. Install the deck engagement cable into the bracket on the rear of the mower deck (Fig. 824).



Fig 824

PICT-9709

4. Install a hairpin cotter into the deck engagement cable flange to secure it to the rear of the mower deck (Fig. 825).

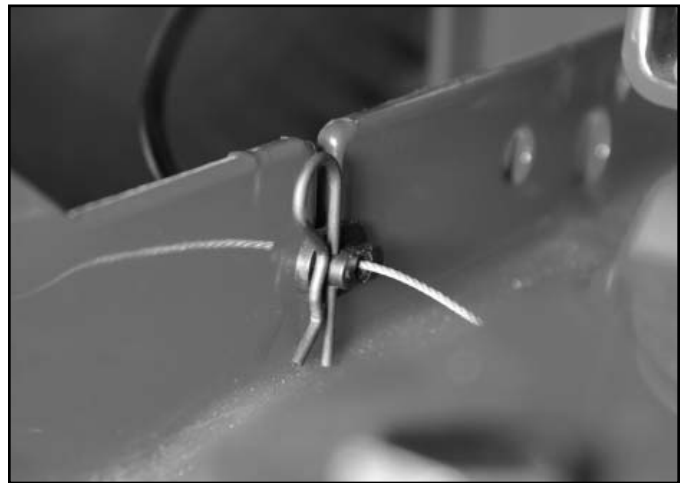

Fig 825

PICT-9706

# MOWER DECK

5. Place blocks under the mower deck to raise it up.
6. Slide the front adjustment deck rod into the deck hanger bracket on the front of the mower deck (Fig. 826).

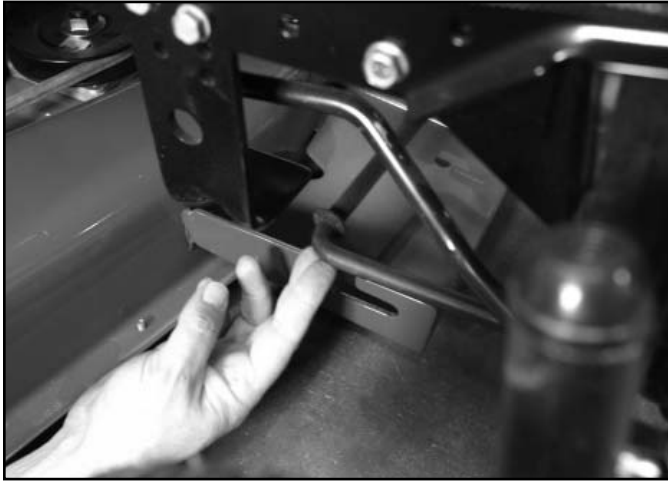

Fig 826

PICT-9715

8. Slide the mower deck toward the rear of the tractor so the deck pins line up with the deck lift arms.
9. Pull the rear right and left deck support pins outward and position the rear deck hanger bracket holes in line with the pins. Release the pins to secure the rear of the mower deck (Fig. 828).



Fig 828

PICT-9713

7. Lower the lift lever to the lowest height-of-cut setting (Fig. 827).



Fig 827

PICT-9701

10. Install the mower deck belt around the lower engine pulley (Fig. 829).



Fig 829

PICT-9704

# MOWER DECK

11. Raise the lift lever to the highest height-of-cut setting (Fig. 830).



Fig 830

PICT-9717

2. Insert a 3/8"-drive ratchet wrench (set to tighten) into the square hole found in the idler bracket at the left side of the mower. Grasp the ratchet's handle and pivot it to relieve tension on the belt (Fig. 832).

**Note:** The left belt cover has been removed for photo purposes.



Fig 832

PICT-9754

## 50" Mower Deck Removal

1. Lower the lift lever to the lowest height-of-cut setting (Fig. 831).



Fig 831

PICT-9768

3. With belt tension relieved, carefully remove the belt from around the electric PTO clutch pulley (Fig. 833).



Fig 833

PICT-9755

7

# MOWER DECK

4. Pull the rear right and left deck support pins outward from the deck lift arms (Fig. 834).



Fig 834

PICT-9759

6. Slide the cutting deck toward the front of the tractor allowing the hooks on the deck to release from the deck stabilizer rod (Fig. 836).

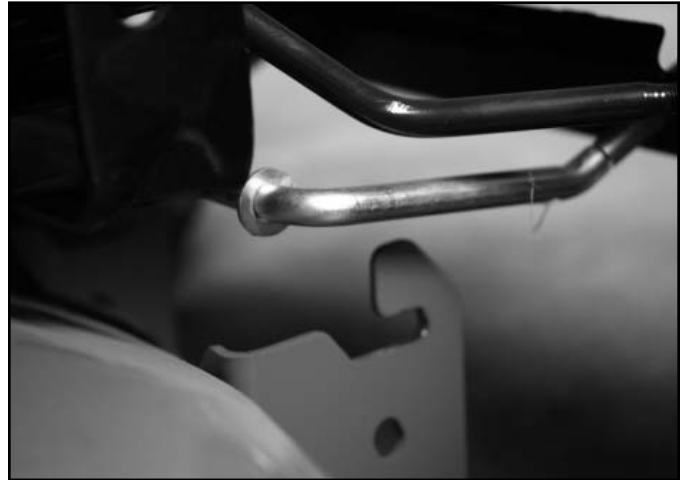

Fig 836

PICT-9764

5. Raise the lift lever to the highest height-of-cut setting (Fig. 835).



Fig 835

PICT-9766

7. Slide the cutting deck (from the right side) out from underneath the tractor (Fig. 837).



Fig 837

PICT-9765

7

# MOWER DECK

## 50" Mower Deck Installation

1. Raise the lift lever to the highest height-of-cut setting (Fig. 838).



Fig 838

PICT-9766

2. Slide the cutting deck (from the right side) underneath the tractor (Fig. 839).



Fig 839

PICT-9765

3. Slide the cutting deck toward the front of the tractor allowing the hooks on the deck to hook onto the deck stabilizer rod (Fig. 840).

**Note:** Ensure the flanges on the stabilizer rod are on the inside of the hooks on the deck.



Fig 840

PICT-9771

4. Place blocks under the rear of the mower deck to raise it up.
5. Lower the lift lever to the lowest height-of-cut setting (Fig. 841).



Fig 841

PICT-9768

7

# MOWER DECK

- Line the lift arms up with the rear right and left deck support pins. Pull the rear deck support pins outward and install the pins into the deck lift arms (Fig. 842).



Fig 842

PICT-9773

- With belt tension relieved, install the belt around the electric PTO clutch pulley (Fig. 844).



Fig 844

PICT-9755

- Insert a 3/8"-drive ratchet wrench (set to tighten) into the square hole found in the idler bracket at the left side of the mower. Grasp the ratchet's handle and pivot it to relieve tension on the belt (Fig. 843).

**Note:** The left belt cover has been removed for photo purposes.



Fig 843

PICT-9754

- Lower the lift lever to the lowest height-of-cut setting (Fig. 845).



Fig 845

PICT-9768

# MOWER DECK

---

**THIS PAGE INTENTIONALLY LEFT BLANK.**

**7**



## Electrical System

The LX Lawn Tractor electrical components and electrical troubleshooting topics can be found in the 2006 LX Series Lawn Tractors / GT2000 Series Garden Tractors Demystification Guide (492-9161) along with complete wiring and circuit diagrams to help diagnose electrical problems.

**THIS PAGE INTENTIONALLY LEFT BLANK.**





# LX Lawn Tractor Service Manual