



Count on it.

Operator's Manual

**Groundsmaster® 3280-D 2 &
4-Wheel Drive Traction Units**

Model No. 30344—Serial No. 270000601 and Up

Model No. 30345—Serial No. 270000601 and Up

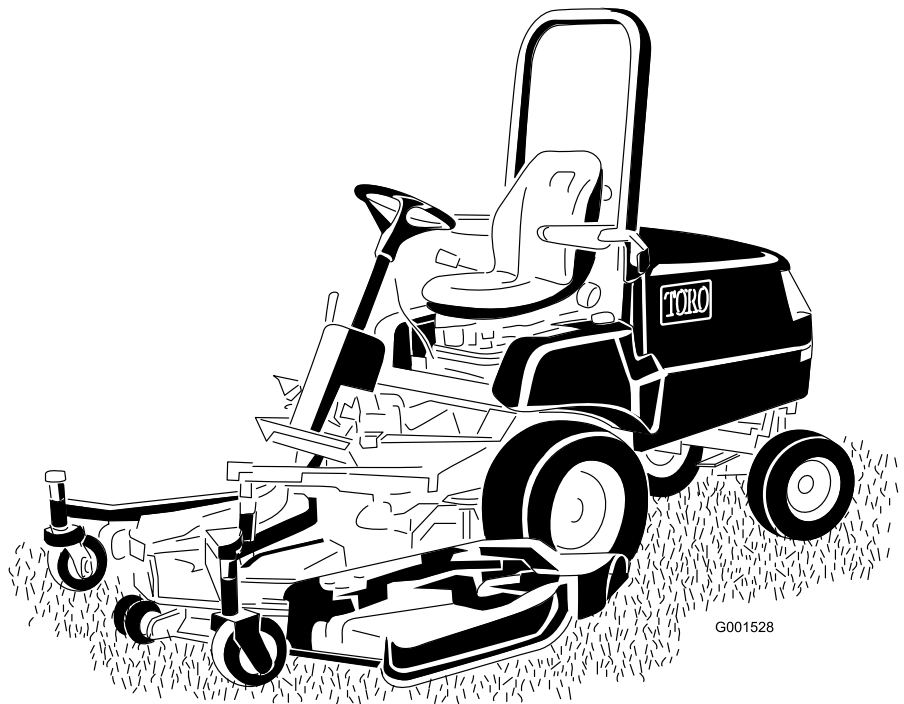

G001528

Warning

CALIFORNIA Proposition 65 Warning

Diesel engine exhaust and some of its constituents are known to the State of California to cause cancer, birth defects, and other reproductive harm.

This spark ignition system complies with Canadian ICES-002.

Important: This engine is not equipped with a spark arrester muffler. It is a violation of California Public Resource Code Section 4442 to use or operate the engine on any forest-covered, brush-covered, or grass-covered land. Other states or federal areas may have similar laws.

Introduction

Read this information carefully to learn how to operate and maintain your product properly and to avoid injury and product damage. You are responsible for operating the product properly and safely.

You may contact Toro directly at www.Toro.com for product and accessory information, help finding a dealer, or to register your product.

Whenever you need service, genuine Toro parts, or additional information, contact an Authorized Service Dealer or Toro Customer Service and have the model and serial numbers of your product ready. Figure 1 identifies the location of the model and serial numbers on the product. Write the numbers in the space provided.

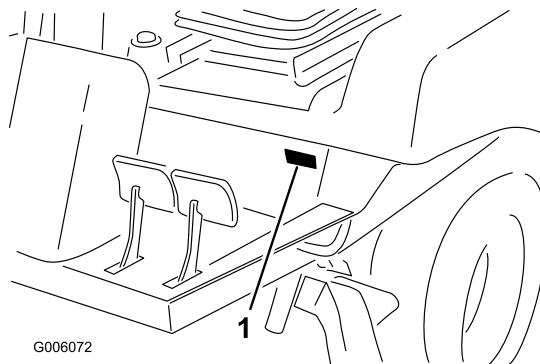

Figure 1

1. Model and serial number location

Model No. _____

Serial No. _____

This manual identifies potential hazards and has safety messages identified by the safety alert symbol (Figure 2), which signals a hazard that may cause serious injury or death if you do not follow the recommended precautions.



Figure 2

1. Safety alert symbol.

This manual uses two other words to highlight information. **Important** calls attention to special mechanical information and **Note** emphasizes general information worthy of special attention.

Contents

Introduction.....	2
Safety	4
Safe Operating Practices	4
Toro Riding Mower Safety	6
Safety and Instructional Decals	8
Setup.....	14
1 Installing the Steering Wheel	15
2 Installing the Hood Handle	15
3 Installing the Seat.....	16
4 Installing the Seat Belt.....	16
5 Installing the Manual Tube	16
6 Adjusting the ROPS.....	17
7 Activating and Charging the Battery.....	17
8 Checking the Tire Pressure.....	19
9 Adjusting the Counterbalance Pressure.....	19
10 Installing Rear Weights.....	21
11 Checking Fluid Levels	23
12 Reading the Manuals and Viewing the Training Materials.....	23
Product Overview	24
Controls	24
Specifications	27
Attachments/Accessories.....	27
Operation.....	27
Checking the Engine Oil Level.....	27
Checking the Cooling System	28
Checking the Hydraulic System.....	28
Adding Fuel	29
Checking the Rear Axle Lubricant (Model 30345 only)	30
Checking the Bidirectional Clutch Lubricant (Model 30345 only).....	31
Using the Rollover Protection System (ROPS)	31
Starting/Stopping the Engine	32
Bleeding the Fuel System	32
Checking the Interlock System.....	33
Pushing or Towing the Machine	33
Standard Control Module (SCM)	34
Operating Tips	36
Maintenance.....	37
Recommended Maintenance Schedule(s)	37
Daily Maintenance Checklist.....	38
Lubrication.....	39
Greasing the Bearings and Bushings.....	39
Engine Maintenance.....	42
General Air Cleaner Maintenance	42
Changing the Engine Oil And Filter	43
Fuel System Maintenance	44
Servicing the Water Separator	44
Cleaning the Fuel Tank	44

Fuel Lines and Connections.....	44
Bleeding Air From the Injectors	44
Electrical System Maintenance.....	45
Servicing the Battery.....	45
Storing the Battery.....	45
Servicing the Wiring Harness.....	45
Accessing the Fuses.....	46
Drive System Maintenance	46
Changing the Rear Axle Lubricant (Model 30345 only)	46
Checking Steering Cylinder Bolt Torque (Model 30345 only).....	46
Changing the Bidirectional Clutch Lubricant (Model 30345 only).....	47
Adjusting the Traction Drive for Neutral	47
Adjusting Rear Wheel Toe-in	48
Adjusting Steering Stops (Model 30345 only).....	48
Cooling System Maintenance	49
Cleaning the Radiator and the Screen.....	49
Brake Maintenance	50
Adjusting the Parking Brake Interlock Switch	50
Adjusting the Service Brakes.....	50
Belt Maintenance.....	51
Checking the Alternator Belt	51
Servicing the PTO Belt.....	51
Controls System Maintenance.....	52
Adjusting the PTO Clutch	52
Adjusting the Traction Pedal.....	52
Adjusting the Tilt Steering Control.....	53
Hydraulic System Maintenance	54
Changing the Hydraulic Oil And Filter	54
Storage.....	55
Machine	55
Engine	55
Schematics	56

Safety

This machine meets or exceeds CEN standard EN 836:1997, ISO standard 5395:1990 (when appropriate decals applied), and ANSI B71.4-2004 specifications in effect at the time of production when equipped with rear weight as listed in the implement Operator's Manual.

Improper use or maintenance by the operator or owner can result in injury. To reduce the potential for injury, comply with these safety instructions and always pay attention to the safety alert symbol, which means CAUTION, WARNING, or DANGER—"personal safety instruction." Failure to comply with the instruction may result in personal injury or death.

Safe Operating Practices

The following instructions are from the CEN standard EN 836:1997, ISO standard 5395:1990, and ANSI B71.4-2004.

Training

- Read the *Operator's Manual* and other training material carefully. If the operator or mechanic can not read the language of this manual it is the owner's responsibility to explain this material to them.
- Be familiar with the controls, safety signs, and the proper use of the equipment.
- Never allow children or people unfamiliar with these instructions to use or service the mower. Local regulations may restrict the age of the operator.
- Never mow while people, especially children, or pets are nearby.
- Keep in mind that the operator or user is responsible for accidents or hazards occurring to other people or their property.
- Do not carry passengers.
- All operators and mechanics should seek and obtain professional and practical instruction. The owner is responsible for training the users. Such instruction should emphasize:
 - the need for care and concentration when working with ride-on machines;
 - control of a ride-on machine sliding on a slope will not be regained by the application of the brake. The main reasons for loss of control are:
 - ◇ insufficient wheel grip;
 - ◇ being driven too fast;
 - ◇ inadequate braking;
 - ◇ the type of machine is unsuitable for its task;

- ◇ lack of awareness of the effect of ground conditions, especially slopes;
- ◇ incorrect hitching and load distribution.

- The owner/user can prevent and is responsible for accidents or injuries occurring to himself or herself, other people, or property.

Preparation

- While mowing, always wear substantial footwear, long trousers, hard hat, safety glasses, and hearing protection. Long hair, loose clothing, or jewelry may get tangled in moving parts. Do not operate the equipment when barefoot or wearing open sandals.
- Thoroughly inspect the area where the equipment is to be used and remove all objects which may be thrown by the machine.
- Warning-Fuel is highly flammable. Take the following precautions:
 - Store fuel in containers specifically designed for this purpose.
 - Refuel outdoors only and do not smoke while refueling.
 - Add fuel before starting the engine. Never remove the cap of the fuel tank or add fuel while the engine is running or when the engine is hot.
 - If fuel is spilled, do not attempt to start the engine but move the machine away from the area of spillage and avoid creating any source of ignition until fuel vapors have dissipated.
 - Replace all fuel tanks and container caps securely.
- Replace faulty silencers/mufflers.
- Evaluate the terrain to determine what accessories and attachments are needed to properly and safely perform the job. Only use accessories and attachments approved by the manufacturer.
- Check the operator presence controls, safety switches and shields to make sure they are attached and functioning properly. Do not operate unless they are functioning properly.



Adequate rear weight is necessary to prevent the rear wheels from leaving the ground. Do not stop suddenly while deck or implement is raised. Do not travel down hill with the deck or implement raised. If the rear wheel leaves the ground, steering is lost.

Operation

- Do not operate the engine in a confined space where dangerous carbon monoxide fumes can collect.



Engine exhaust contains carbon monoxide, which is an odorless, deadly poison that can kill you.

Do not run engine indoors or in an enclosed area.

- Mow only in daylight or in good artificial light.
- Before attempting to start the engine, disengage all blade attachment clutches, shift into neutral, and engage the parking brake.
- Do not put hands or feet near or under rotating parts. Keep clear of the discharge opening at all times.
- Remember there is no such thing as a safe slope. Travel on grass slopes requires particular care. To guard against overturning:
 - do not stop or start suddenly when going up or downhill;
 - machine speeds should be kept low on slopes and during tight turns;
 - stay alert for humps and hollows and other hidden hazards;
 - never mow across the face of the slope.
- Stay alert for holes in the terrain and other hidden hazards.
- Watch out for traffic when crossing or near roadways.
- Stop the blades rotating before crossing surfaces other than grass.
- Never direct the discharge of material toward bystanders nor allow anyone near the machine while in operation.
- Never operate the machine with damaged guards, shields, or without safety protective devices in place. Be sure all interlocks are attached, adjusted properly, and functioning properly.
- Do not change the engine governor settings or over speed the engine. Operating the engine at excessive speed may increase the hazard of personal injury.
- Before leaving the operator's position:
 - stop on level ground;
 - disengage the power take-off and lower the attachments;
 - Set the parking brake;

- stop the engine and remove the key.
- Disengage drive to attachments when transporting or not in use.
- Stop the engine and disengage drive to attachment
 - before refuelling;
 - before removing the grass catcher/catchers;
 - before making height adjustment unless adjustment can be made from the operator's position.
 - before clearing blockages;
 - before checking, cleaning or working on the mower;
 - after striking a foreign object or if an abnormal vibration occurs. Inspect the mower for damage and make repairs before restarting and operating the equipment.
- Keep hands and feet away from the mower deck.
- Look behind and down before backing up to be sure of a clear path.
- Slow down and use caution when making turns and crossing roads and sidewalks. Disengage blades if not mowing.
- Be aware of the mower discharge direction and do not point it at anyone.
- Do not operate the mower under the influence of alcohol or drugs
- Use care when loading or unloading the machine into a trailer or truck
- Use care when approaching blind corners, shrubs, trees, or other objects that may obscure vision.

Maintenance and Storage

- Keep all nuts, bolts and screws tight to be sure the equipment is in safe working condition.
- Never store the equipment with fuel in the tank inside a building where fumes may reach an open flame or spark.
- Allow the engine to cool before storing in any enclosure.
- To reduce the fire hazard, keep the engine, silencer/muffler, battery compartment and fuel storage area free of grass, leaves, or excessive grease.
- Keep all parts in good working condition and all hardware and hydraulic fittings tightened. Replace all worn or damaged parts and decals
- If the fuel tank has to be drained, do this outdoors.
- Be careful during adjustment of the machine to prevent entrapment of the fingers between moving blades and fixed parts of the machine.

- On multi-spindle mowers, take care as rotating one blade can cause other blades to rotate.
- Disengage drives, lower the deck, set parking brake, stop engine and remove the key from the ignition. Wait for all movement to stop before adjusting, cleaning or repairing.
- Clean grass and debris from decks, drives, silencers/mufflers, engine and underside of machine to help prevent fires. Clean up oil or fuel spillage.
- Use jack stands to support components when required.
- Carefully release pressure from components with stored energy.
- Disconnect battery before making any repairs. Disconnect the negative terminal first and the positive last. Reconnect positive first and negative last.
- Use care when checking the blades. Wear gloves and use caution when servicing them. Only replace blades. Never straighten or weld them.
- Keep hands and feet away from moving parts. If possible, do not make adjustments with the engine running.
- Charge batteries in an open well ventilated area, away from spark and flames. Unplug charger before connecting or disconnecting from battery. Wear protective clothing and use insulated tools.
- Using the machine demands attention. To prevent loss of control:
 - Do not drive close to sand traps, ditches, creeks, or other hazards.
 - Reduce speed when making sharp turns. Avoid sudden stops and starts.
 - This machine is not designed or equipped for on-road use and is a “slow-moving vehicle.” If you must cross or travel on a public road, you should be aware of and comply with local regulations, such as required lights, slow moving vehicle signs, and reflectors.
 - When near or crossing roads, always yield the right-of-way.
 - Apply the service brakes when going downhill to keep forward speed slow and to maintain control of the machine.
- Raise the deck when driving from one work area to another.
- Do not touch the engine, silencer/muffler, or exhaust pipe while the engine is running or soon after it has stopped because these areas could be hot enough to cause burns.
- If the engine stalls or machine cannot make it to the top of a slope, do not turn the machine around. Always back slowly, straight down the slope.
- When a person or pet appears unexpectedly in or near the mowing area, stop mowing. Careless operation, combined with terrain angles, ricochets, or improperly positioned guards can lead to thrown object injuries. Do not resume mowing until the area is cleared.

Toro Riding Mower Safety

The following list contains safety information specific to Toro products or other safety information that you must know that is not included in the CEN, ISO, or ANSI standard.

This product is capable of amputating hands and feet and throwing objects. Always follow all safety instructions to avoid serious injury or death.

Use of this product for purposes other than its intended use could prove dangerous to user and bystanders.

- Know how to stop the engine quickly.
- Do not operate the machine while wearing tennis shoes or sneakers.
- Wearing safety shoes and long pants is advisable and required by some local ordinances and insurance regulations.
- Handle fuel carefully. Wipe up any spills.
- Check the safety interlock switches daily for proper operation. If a switch should fail, replace the switch before operating the machine.
- Before starting the engine, sit on the seat.

Using the Rollover Protection System (ROPS)

- Keep the roll bar in the raised and locked position and use the seat belt when operating the machine.
- Be certain that the seat belt can be released quickly in the event of an emergency.
- Be aware there is no rollover protection when the roll bar is down.
- Check the area to be mowed and never fold down the ROPS in areas where there are slopes, drop offs or water.
- Lower the rollbar only when absolutely necessary. Do not wear the seat belt with the roll bar folded down.
- Check carefully for overhead clearances (i.e branches, doorways, electrical wires) before driving under any objects and do not contact them.

Maintenance and Storage

- Make sure all hydraulic line connectors are tight and all hydraulic hoses and lines are in good condition before applying pressure to the system.
- Keep your body and hands away from pin hole leaks or nozzles that eject hydraulic fluid under high pressure. Use paper or cardboard, not your hands, to search for leaks. Hydraulic fluid escaping under pressure can have sufficient force to penetrate the skin and cause serious injury. Seek immediate medical attention if fluid is injected into skin.
- Before disconnecting or performing any work on the hydraulic system, all pressure in the system must be relieved by stopping the engine and lowering the deck and attachments to the ground.
- Check all fuel lines for tightness and wear on a regular basis. Tighten or repair them as needed.
- If the engine must be running to perform a maintenance adjustment, keep hands, feet, clothing, and any parts of the body away from the deck, attachments, and any moving parts, especially the screen at the side of the engine. Keep everyone away.
- If major repairs are ever needed or if assistance is desired, contact an Authorized Toro Distributor.
- Use only Toro approved attachments and replacement parts. The warranty may be voided if used with unapproved attachments.

Sound Pressure Level

This unit has an equivalent continuous A-weighted sound pressure at the operator ear of: 90 dB(A), based on measurements of identical machines per EN 11094 and EN 836.

Sound Power Level

This unit has a sound power level of: 105 dB(A) 1 pW, based on measurements of identical machines per EN 11094.

Vibration Level

Hand-Arm

This unit does not exceed a vibration level of 2.5 m/s² at the hands based on measurements of identical machines per EN 1033 and ISO 5349.

Whole Body

This unit does not exceed a vibration level of .5 m/s² at the posterior based on measurements of identical machines per EN 1032.

Posterior

This unit does not exceed a vibration level of 0.5 m/s² at the posterior based on measurements of identical machines per ISO 2631.

Safety and Instructional Decals



Safety decals and instructions are easily visible to the operator and are located near any area of potential danger. Replace any decal that is damaged or lost.

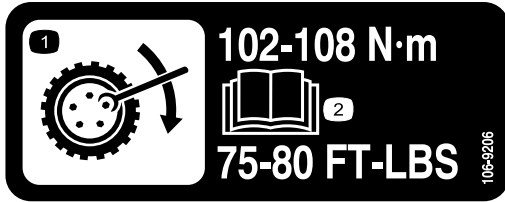

106-9206

1. Wheel torque specifications
2. Read the *Operator's Manual*.

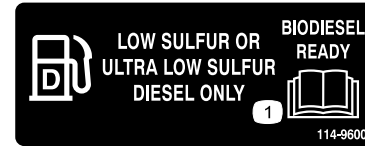

114-9600

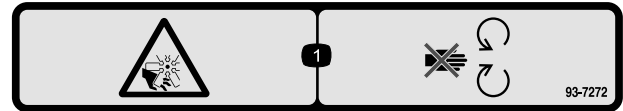

93-7272

1. Cutting/dismemberment hazard; fan—stay away from moving parts.

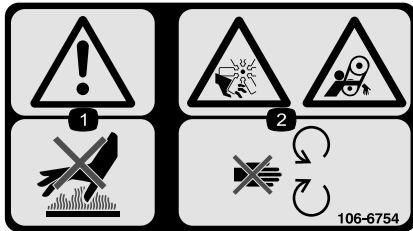

106-6754

1. Warning—do not touch the hot surface.
2. Cutting/dismemberment hazard, fan and entanglement hazard, belt—stay away from moving parts.



93-6697

1. Read the *Operator's Manual*.
2. Add SAE 80w-90 (API GL-5) oil every 50 hours.

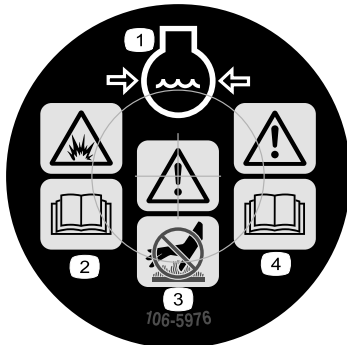

106-5976

1. Engine coolant under pressure
2. Explosion hazard—read the *Operator's Manual*.
3. Warning—do not touch the hot surface.
4. Warning—read the *Operator's Manual*.



93-6686

1. Hydraulic oil
2. Read the *Operator's Manual*.



105-2511

1. Read *Operator's Manual* for starting instructions.

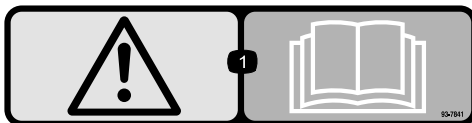

93-7841

1. Warning—read the *Operator's Manual*.

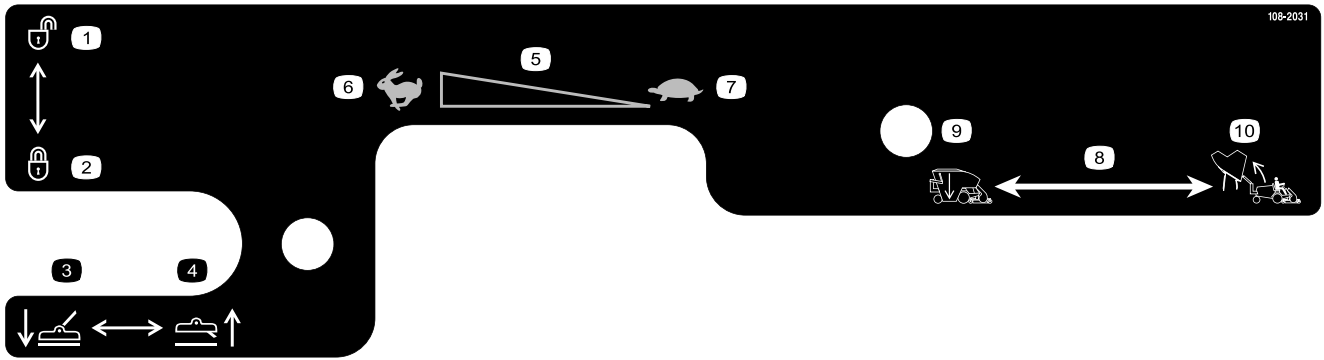

108-2031

- | | | | |
|----------------------------|----------------------------|---------------------|----------------------|
| 1. Unlocked | 4. Raise the cutting units | 7. Slow | 10. Raise the hopper |
| 2. Locked | 5. Engine speed | 8. Hopper control | |
| 3. Lower the cutting units | 6. Fast | 9. Lower the hopper | |

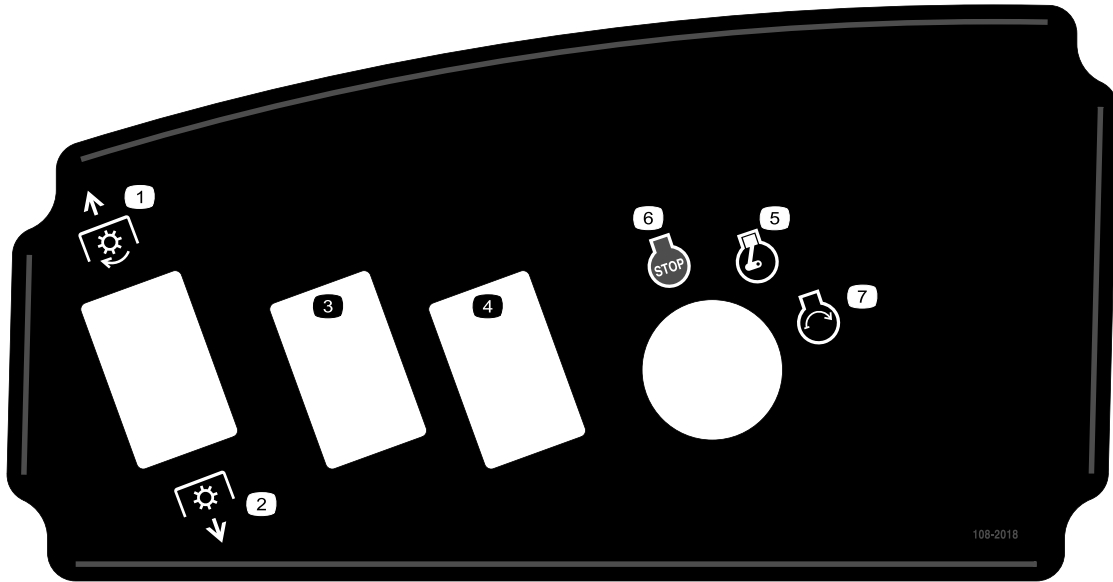

108-2018

- | | | | |
|------------|-----------------------|----------------|-----------------|
| 1. PTO—Off | 3. Optional Equipment | 5. Engine—Run | 7. Engine—Start |
| 2. PTO—On | 4. Optional Equipment | 6. Engine—Stop | |

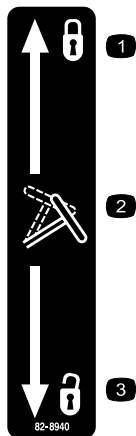

82-8940

- | | |
|------------------|-------------|
| 1. Locked | 3. Unlocked |
| 2. Tilt steering | |



105-7179

- | | |
|------------------------------------|------------------|
| 1. Read <i>Operator's Manual</i> . | 2. Parking brake |
|------------------------------------|------------------|

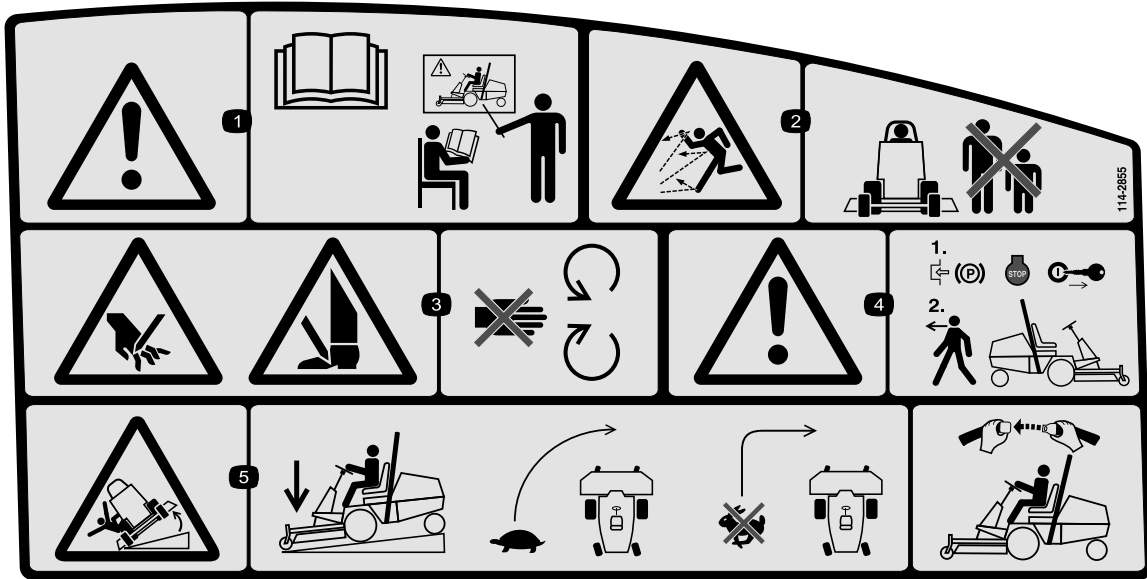

114-2855

1. Warning—read the *Operator's Manual*, all operators should be trained before operating the machine.
2. Thrown object hazard—keep bystanders a safe distance from the machine and keep the deflector in place.
3. Cutting/dismemberment hazard of hands or feet, mower blade—stay away from moving parts.
4. Warning—engage the parking brake, and remove the ignition key before leaving the machine.
5. Tipping hazard—when driving down slopes, lower the cutting unit, slow machine before turning, do not turn at high speeds, and if the roll bar is installed, wear the seat belt.

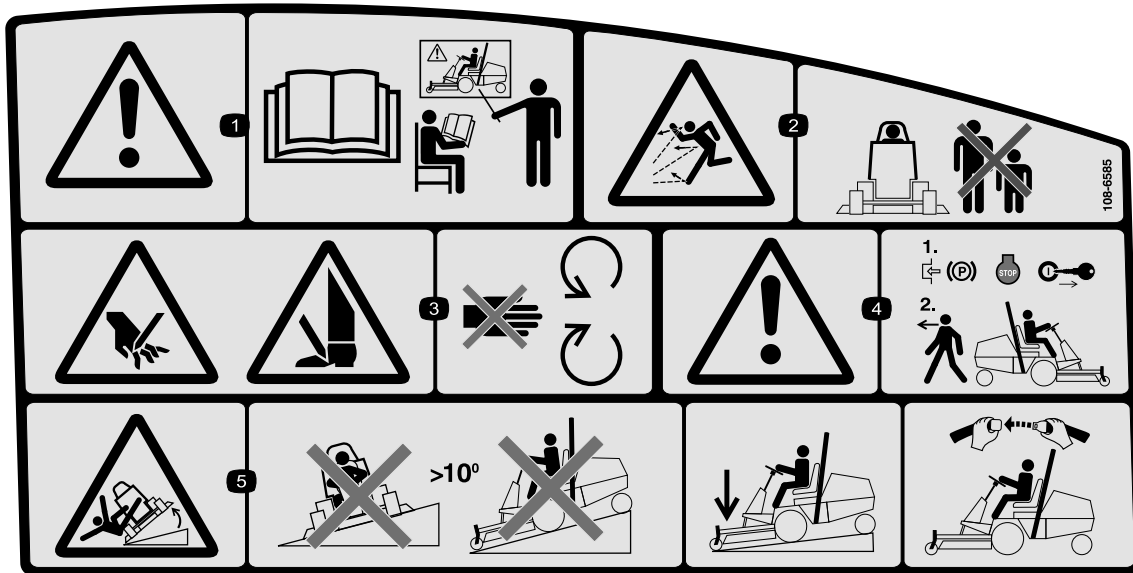

108-6585

(Apply over 114-2855 for CE)

1. Warning—read the *Operator's Manual*, all operators should be trained before operating the machine.
2. Thrown object hazard—keep bystanders a safe distance from the machine and keep the deflector in place.
3. Cutting/dismemberment hazard of hands or feet, mower blade—stay away from moving parts.
4. Warning—engage the parking brake, and remove the ignition key before leaving the machine.
5. Tipping hazard—do not drive the machine on a slope greater than 10 degrees; when driving down slopes, lower the cutting unit, and if the roll bar is raised, wear the seat belt.

GM 3280-D QUICK REFERENCE AID

CHECK/SERVICE

1. Oil Levels (Engine / Trans.)
2. Coolant level
3. Tire pressure
4. Belts (Fan & PTO)
5. Fuel – Diesel Only
6. Battery
7. Grease, Lube points
8. Radiator screen
9. Air Cleaner
10. Electric clutch gap .015-.030
11. PTO Belt tension
12. Water separator
13. Fuel Filter

FLUID SPECIFICATIONS
*See operator's manual for initial changes.

	CAPACITY	*CHANGE INTERVALS
Engine oil	3.9 QT. <small>WITH FILTER</small>	OIL & FILTER 150 HRS.
Trans oil	6 QT.	FILTER 200 HRS.
Fuel	12.8 GAL.	FILTER 400 HRS.
Coolant	8 QT.	1500 HRS.

FILTERS

A. Air	98-9763
B. Fuel	98-7612
C. Fuel	98-9764
D. Trans. Oil	23-2300
E. Engine Oil	104-5167

PART NO.

98-9763
98-7612
98-9764
23-2300
104-5167

108-6583

108-6583

1. Read the *Operator's Manual*.

106-9290

- | | | | |
|------------------------------|-------------------------|---------------------------|-----------|
| 1. Inputs | 5. In seat | 9. Outputs | 13. Start |
| 2. Not active | 6. Power Take-off (PTO) | 10. Power Take Off (PTO) | 14. Power |
| 3. High temperature shutdown | 7. Parking brake Off | 11. Start | |
| 4. High temperature warning | 8. Neutral | 12. Energize to Run (ETR) | |



108-2073

1. Warning—there is no rollover protection when the roll bar is down.
2. To avoid injury or death from a rollover accident, keep the roll bar in the raised and locked position and wear the seat belt. Lower the roll bar only when absolutely necessary; do not wear the seat belt when the roll bar is down.
3. Read the *Operator's Manual*; drive slowly and carefully.

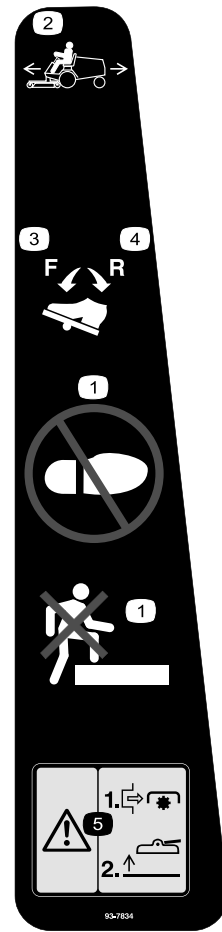

93-7834

- | | |
|--|--|
| <ol style="list-style-type: none"> 1. No step 2. Traction pedal 3. Traction-forward | <ol style="list-style-type: none"> 4. Traction-reverse 5. Warning—shut off PTO prior to raising decks; do not operate decks when they are in raised position |
|--|--|



Battery Symbols

Some or all of these symbols are on your battery

- | | |
|--|--|
| 1. Explosion hazard | 6. Keep bystanders a safe distance from the battery. |
| 2. No fire, open flame, or smoking. | 7. Wear eye protection; explosive gases can cause blindness and other injuries |
| 3. Caustic liquid/chemical burn hazard | 8. Battery acid can cause blindness or severe burns. |
| 4. Wear eye protection | 9. Flush eyes immediately with water and get medical help fast. |
| 5. Read the <i>Operator's Manual</i> . | 10. Contains lead; do not discard. |

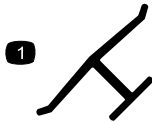

Manufacturer's Mark

1. Indicates the blade is identified as a part from the original machine manufacturer.

Setup

Loose Parts

Use the chart below to verify that all parts have been shipped.

Procedure	Description	Qty.	Use
1	Steering wheel	1	Install the steering wheel.
	Cover	1	
2	Handle	1	Install the hood handle.
	Screws	2	
3	Seat, Model 30398 and the Mechanical Seat Suspension Kit, Model No. 30312 or the Pneumatic Seat Suspension Kit, Model No. 30313 (obtained separately)	1	Install the seat.
4	Seat belt	2	Install the seat belt.
	Bolts	2	
	Lock washer	2	
	Flat washer	2	
5	Manual tube	1	Install the manual tube.
	R-clamp	2	
6	No parts required	–	Adjust the ROPS.
7	No parts required	–	Activate and charge the battery.
8	No parts required	–	Check the tire pressure.
9	No parts required	–	Adjust the counterbalance pressure.
10	Rear weight kit(s) as needed	-	Install rear weights if needed.
11	No parts required	–	Check the rear axle lubricant, hydraulic fluid, and engine oil levels
12	Operator's Manual	2	Read the manuals and watch the training materials before operating the machine. Use the remaining parts for the installation of attachments.
	Engine Operator's Manual	1	
	Parts Catalog	1	
	Operator Training Material	1	
	Pre-delivery Inspection Sheet	1	
	CE certificate	1	
	Certificate of Quality	1	
	Roll pin	1	
	Bolt (5/16 x 1-3/4 inches)	2	
	Lock nut (5/16 inch)	2	
	Cylinder pin	2	
	Cotter pin (3/16 x 1-1/2 inches)	4	
Brake return springs	2		

Note: Determine the left and right sides of the machine from the normal operating position.



The PTO universal shaft is attached to the machine frame. Do not engage the PTO without first removing the universal shaft or coupling it to a suitable implement.

1

Installing the Steering Wheel

Parts needed for this procedure:

1	Steering wheel
1	Cover

Procedure

1. Remove the steering wheel from the shipping skid.

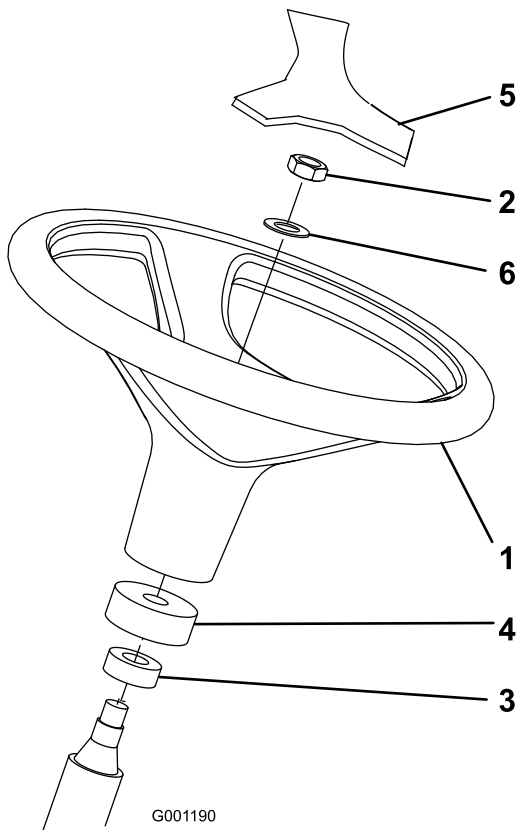

Figure 3

- | | |
|-------------------|----------------|
| 1. Steering wheel | 4. Foam collar |
| 2. Jam nut | 5. Cover |
| 3. Dust cover | 6. Washer |

2. Remove the jam nut and washer from the steering shaft. Ensure that the foam collar and dust cover remain on the steering shaft (Figure 3).

3. Slide the steering wheel and washer onto the steering shaft (Figure 3).
4. Secure the steering wheel to the shaft with the jam nut. Tighten the jam nut to 20-26 ft-lb.
5. Mount the cover to the steering wheel (Figure 3).

2

Installing the Hood Handle

Parts needed for this procedure:

1	Handle
2	Screws

Procedure

1. Remove and discard the 2 screws and nuts securing the hood cable bracket and to the underside of the hood (Figure 4).

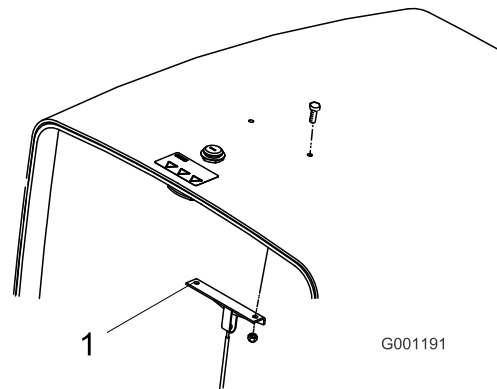

Figure 4

1. Hood cable bracket
-
2. Mount the handle and the cable bracket to the hood with 2 screws (Figure 5).

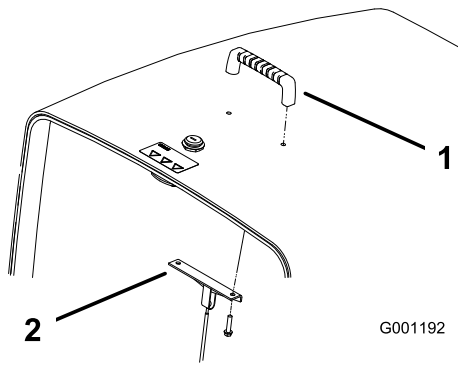

Figure 5

- 1. Handle
- 2. Hood cable bracket

4

Installing the Seat Belt

Parts needed for this procedure:

2	Seat belt
2	Bolts
2	Lock washer
2	Flat washer

Procedure

Install each end of the seat belt in the holes in the back of the seat with 2 bolts (7/16 x 1 inch), flat washers (7/16 inch), and lock washers (7/16 inch) (Figure 6).

Important: Mount the latch side of the belt to the right side of the seat.

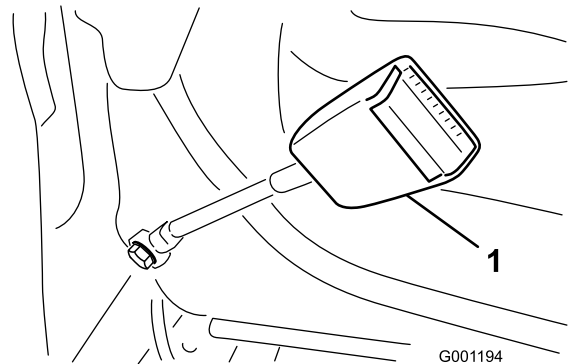

Figure 6

- 1. Seat belt latch

3

Installing the Seat

Parts needed for this procedure:

1	Seat, Model 30398 and the Mechanical Seat Suspension Kit, Model No. 30312 or the Pneumatic Seat Suspension Kit, Model No. 30313 (obtained separately)
---	---

Procedure

The Groundsmaster 3280-D is shipped without the seat assembly. The optional Seat, Model 30398 and the Mechanical Seat Suspension Kit, Model No. 30312 or the Pneumatic Seat Suspension Kit, Model No. 30313 must be obtained and installed. Refer to the seat kit for the installation instructions.

Note: An Auxiliary Power Unit Kit, Model No. 30382, must be obtained and installed before installing a Pneumatic Suspension Seat Kit to the machine.

Note: Refer to Installing the Manual Tube before the seat is mounted to the seat suspension.

5

Installing the Manual Tube

Parts needed for this procedure:

1	Manual tube
2	R-clamp

Procedure

1. Remove the manual tube and R-clamps secured to the seat plate. Discard the 2 mounting bolts and flat washers.

- Remove the 2 nuts and vinyl caps (if previously installed) securing the upper seat bracket to the left side of the seat suspension (Figure 7).
- Loosely mount the R-clamps to the seat bracket studs with the 2 nuts previously removed. (Figure 7). The R-clamps are to be positioned under the seat suspension tabs.

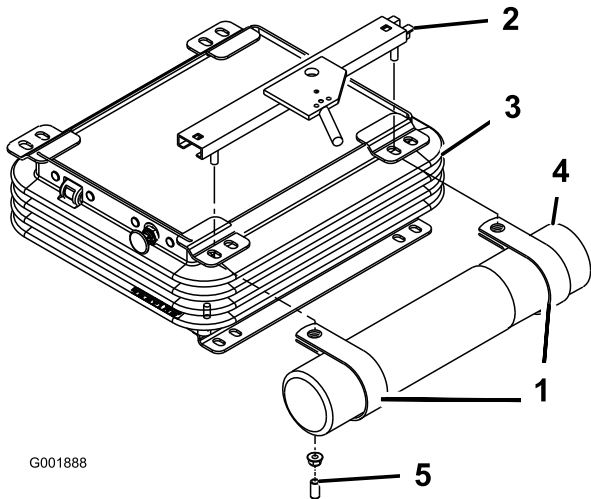

Figure 7

- | | |
|-----------------------|----------------|
| 1. R-clamps | 4. Manual tube |
| 2. Upper seat bracket | 5. Vinyl cap |
| 3. Seat suspension | |

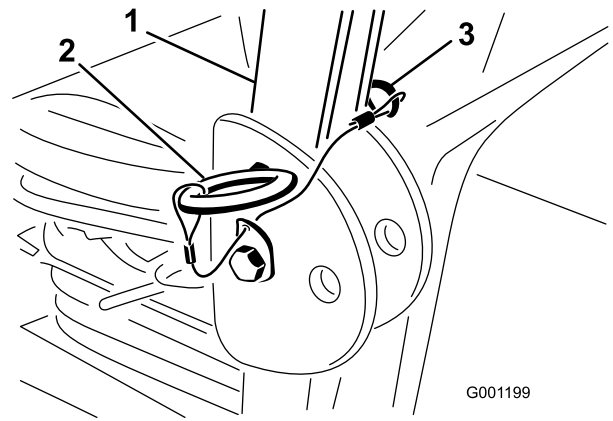

Figure 8

- | | |
|-------------|-----------------------|
| 1. Roll bar | 3. Hairpin cotter pin |
| 2. Pin | |

- Raise the roll bar to the upright position and install the two pins and secure them with the hairpin cotter pins (Figure 8).

Note: If the roll bar must be lowered, lower it slowly so damage to hood does not occur.

7

Activating and Charging the Battery

No Parts Required

Procedure

Use only electrolyte (1.265 Specific Gravity) to fill battery initially.

- Remove the battery from the machine.

Important: Do not add electrolyte while the battery is in the machine. You could spill it, causing corrosion.

- Clean the top of the battery and remove the vent caps (Figure 9).

6

Adjusting the ROPS

No Parts Required

Procedure

- Remove the hairpin cotter pins and remove the two pins from the roll bar (Figure 8).

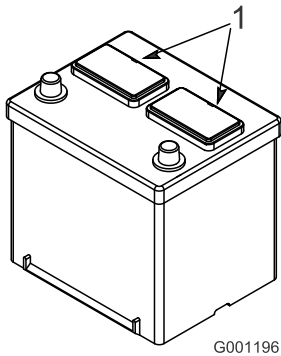

Figure 9

1. Vent caps

3. Carefully fill each cell with electrolyte until the plates are covered with about 1/4 inch (6 mm) of fluid (Figure 10).

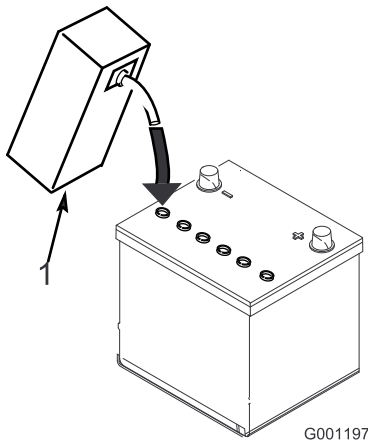

Figure 10

1. Electrolyte

4. Allow approximately 20 to 30 minutes for the electrolyte to soak into the plates. Refill as necessary to bring the electrolyte to within about 1/4 inch (6 mm) of the bottom of the fill well (Figure 10).



Charging the battery produces gasses that can explode.

Never smoke near the battery and keep sparks and flames away from battery.

5. Connect a 3 to 4 amp battery charger to the battery posts. Charge the battery at a rate of 3 to 4 amps until the specific gravity is 1.250 or higher and the temperature is at least 60° F. (16° C) with all cells gassing freely.
6. When the battery is charged, disconnect the charger from the electrical outlet and battery posts.

Note: After the battery has been activated, add only distilled water to replace normal loss, although maintenance-free batteries should not require water under normal operating conditions.

Warning

CALIFORNIA Proposition 65 Warning

**Battery posts, terminals, and related accessories contain lead and lead compounds, chemicals known to the State of California to cause cancer and reproductive harm.
Wash hands after handling.**



Battery terminals or metal tools could short against metal tractor components causing sparks. Sparks can cause the battery gasses to explode, resulting in personal injury.

- **When removing or installing the battery, do not allow the battery terminals to touch any metal parts of the tractor.**
- **Do not allow metal tools to short between the battery terminals and metal parts of the tractor.**

7. Install the battery into the machine.
8. First, install the positive cable (red) to the positive (+) terminal and then the negative cable (black) to the negative (-) terminal of the battery (Figure 11). Slide the rubber boot over the positive terminal to prevent a possible short from occurring.



Incorrect battery cable routing could damage the machine and cables causing sparks. Sparks can cause the battery gasses to explode, resulting in personal injury.

- **Always disconnect the negative (black) battery cable before disconnecting the positive (red) cable.**
- **Always connect the positive (red) battery cable before connecting the negative (black) cable.**

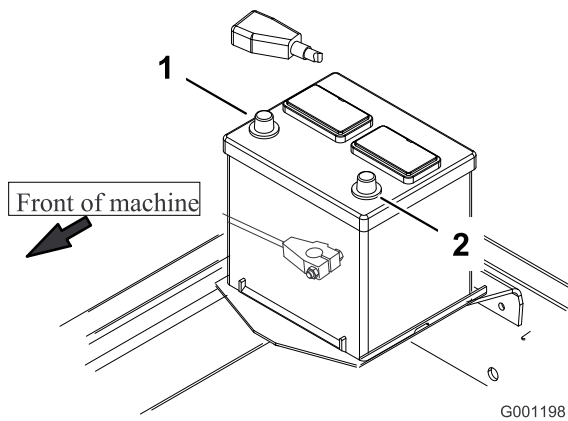

Figure 11

1. Positive (+)
2. Negative (-)

Connecting cables to the wrong post could damage the electrical system and result in personal injury.

Note: Ensure that the battery cables are routed away from any sharp edges or moving parts.

8

Checking the Tire Pressure

No Parts Required

Procedure

The tires are over inflated for shipping. Therefore, release some of the air to reduce the pressure. Correct air pressure in front and rear tires is 20 psi.

9

Adjusting the Counterbalance Pressure

No Parts Required

Procedure

For best performance, the cutting unit bounce on uneven turf is minimal and it does not ride heavily over

flat terrain. If scalping occurs or the cut is uneven from side to side, there may be too much weight on the deck and the weight may have to be transferred to the machine: i.e. increased counterbalance pressure.

By contrast, if too much weight is transferred to the machine, the deck will bounce excessively and the cut will be uneven. If the cutting unit does not perform properly, adjust the counterbalance pressure as follows:

1. Ensure that the parking brake is set, the PTO switch is in the Off position, and the lift lever is in the Float position.
2. Connect a pressure gauge to the test port behind the right lift cylinder (Figure 12).

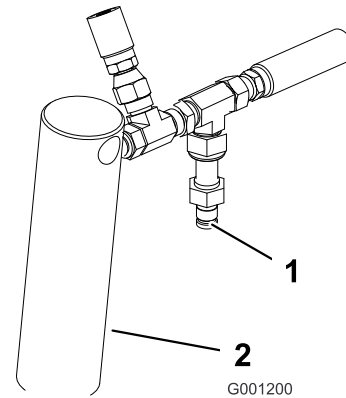

Figure 12

1. Test port
2. Right lift cylinder

3. Loosen the jam nut at the bottom of the counterbalance valve (Figure 13). The valve is located on the right side of the machine.

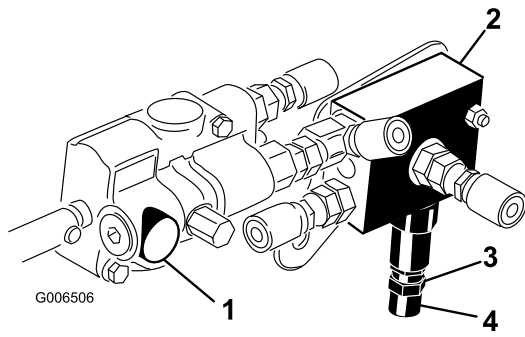

Figure 13

- | | |
|-------------------------|------------|
| 1. Lift valve | 3. Jam nut |
| 2. Counterbalance valve | 4. Spool |

4. Start the engine and set the throttle to high idle.
5. Using an Allen wrench, adjust the lift valve spool until the desired pressure is attained on the gauge. See the chart below for the recommended pressure setting for the cutting deck.

Cutting Deck	Counterbalance Pressure
52 inch Side Discharge Deck (Model 30555)	100 psi
60 inch Side Discharge Deck (Model 30366) or 62 in Rear Discharge Deck (Model 30367) or 62 in Guardian Recycler Deck (Model 30376)	175 psi
72 inch Side Discharge Deck (Model 30368) or 72 in Rear Discharge Deck (Model 30369) or 72 in Guardian Recycler Deck (Model 30379)	220 psi

6. Stop the engine.
7. Tighten the jam nut on the bottom of the counterbalance valve. Torque the nut to 10–12 ft.-lb.
8. Remove the pressure gauge from the test port.

10

Installing Rear Weights

Parts needed for this procedure:

-	Rear weight kit(s) as needed
---	------------------------------

Procedure

The Groundsmaster 3280-D Series machines comply with CEN standard EN 836:1997, ISO standard 5395:1990 and the ANSI B71.4-2004 Standard when equipped with rear weight. 215 lb. of rear weight is installed at the factory. Use charts below to determine combinations of additional weight required. Order parts from your local Authorized Toro Distributor.

Two Wheel Drive Chart	Additional Rear Weight Required	Left Side Weight Required	Weight Part Number	Weight Description	Qty.
52 inch Side Discharge Deck (Model 30555)	0 lb.	0 lb.	-	-	-
52 inch Side Discharge Deck with 15 cu. ft. Hopper	0 lb.	145 lb.*	*77-6700 92-9670 24-5780	75 lb. Wheel Weight Bracket Kit Rear Weight Kit	1 1 1
60 inch Side Discharge Deck (Model 30366) or 62 inch Rear Discharge Deck (Model 30367) or 62 inch Guardian Recycler Deck (Model 30376)	0 lb.	0 lb.	-	-	
60 inch Side Discharge Deck with 15 cu. ft. Hopper	0 lb.	75 lb.*	*77-6700	75 lb. Wheel Weight	1
72 inch Side Discharge Deck (Model 30368) or 72 inch Rear Discharge Deck (Model 30369) or 72 inch Guardian Recycler Deck (Model 30379)	35 lb.	0 lb.	24-5790 325-8 3253-7	Rear Weight, 35 lb Bolt (1/2 x 2 inches) Lock washer (1/2 inch)	1 2 2

* 75 lb. wheel weight (included with 15 cu. ft. hopper) required on left wheel

The Groundsmaster 3280-D 4 Wheel Drive Series machines comply with CEN standard EN 836:1997, ISO standard 5395:1990 and the ANSI B71.4-2004 Standard when equipped with rear weight. 50 lb. of rear weight is installed at the factory. Use charts below to determine combinations of additional weight required. Order parts from your local Authorized Toro Distributor.

Four Wheel Drive Chart	Additional Rear Weight Required	Left Side Weight Required	Weight Part Number	Weight Description	Qty.
52 inch Side Discharge Deck (Model 30555)	0 lb.	0 lb.	-	-	-
52 inch Side Discharge Deck with 15 cu. ft. Hopper	0 lb.	145 lb.*	*77-6700 92-9670 24-5780	75 lb. Wheel Weight Bracket Kit Rear Weight Kit	1 1 1
60 inch Side Discharge Deck (Model 30366) or 62 inch Rear Discharge Deck (Model 30367) or 62 inch Guardian Recycler Deck (Model 30376)	0 lb.	0 lb.	-	-	-
60 inch Side Discharge Deck with 15 cu. ft. Hopper	0 lb.	75 lb.*	*77-6700	75 lb. Wheel Weight	1
72 inch Side Discharge Deck (Model 30368) or 72 inch Rear Discharge Deck (Model 30369) or 72 inch Guardian Recycler Deck (Model 30379)	35 lb.	0 lb.	24-5790 325-8 3253-7	Rear Weight, 35 lb Bolt (1/2 x 2 inches) Lock washer (1/2 inch)	1 2 2

* 75 lb. wheel weight (included with 15 cu. ft. hopper) required on left wheel

11

Checking Fluid Levels

No Parts Required

Procedure

1. Check the rear axle lubricant level before the engine is first started, refer to Checking the Rear Axle Lubricant.

Check the hydraulic fluid level before the engine is first started, refer to Checking the Hydraulic Fluid Level.

2. Check the engine oil level before and after the engine is first started, refer to Checking the Engine Oil Level.

12

Reading the Manuals and Viewing the Training Materials

Parts needed for this procedure:

2	<i>Operator's Manual</i>
1	<i>Engine Operator's Manual</i>
1	<i>Parts Catalog</i>
1	Operator Training Material
1	Pre-delivery Inspection Sheet
1	CE certificate
1	Certificate of Quality
1	Roll pin
2	Bolt (5/16 x 1-3/4 inches)
2	Lock nut (5/16 inch)
2	Cylinder pin
4	Cotter pin (3/16 x 1-1/2 inches)
2	Brake return springs

Procedure

1. Read the manuals.
2. View the Operator DVD.
3. Save the roll pin, bolts (5/16 x 1-3/4 inches), and locknuts (5/16 inch) to secure the universal shaft to an implement.

4. Save the cylinder pin and cotter pin (3/16 x 1-1/2 inches) to secure the deck lift arms to the lift cylinder.
5. Save the brake return springs to mount the deck lift arms.

Product Overview

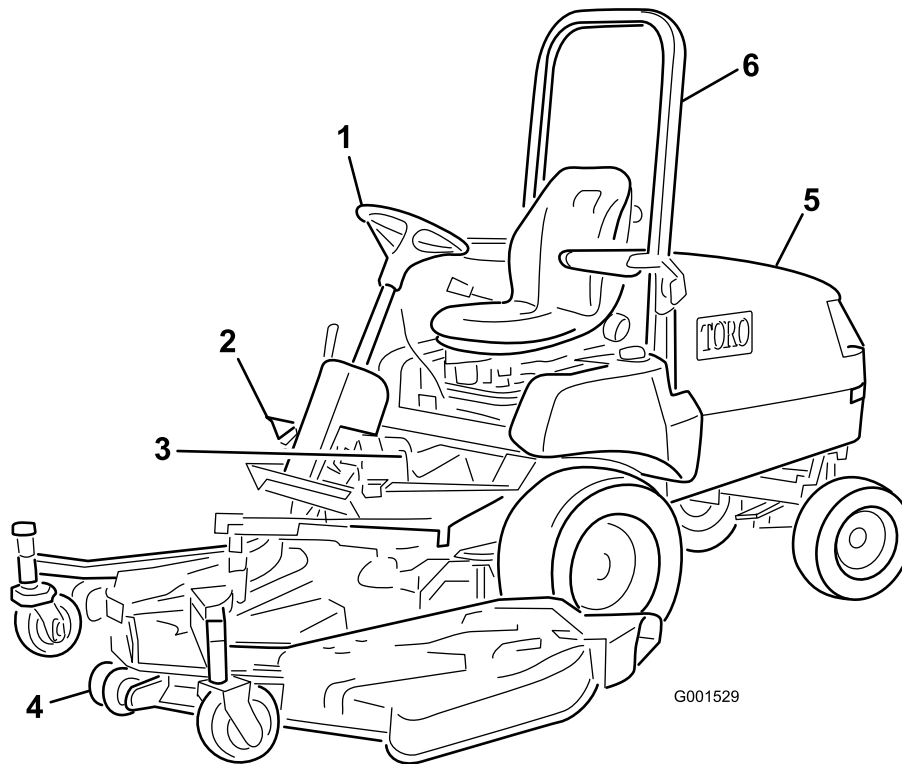

Figure 14

- | | | |
|-------------------|-----------------|--------------------------------------|
| 1. Steering wheel | 3. Brakes | 5. Hood/engine compartment |
| 2. Traction pedal | 4. Cutting unit | 6. ROPS (Rollover Protection System) |

Controls

Service Brakes

The left and right brake pedals (Figure 15) are connected to the left and right front wheels. Since both brakes work independently of each other, the brakes can be used to turn sharply or to increase traction if one wheel tends to slip while operating on certain slope conditions. However, wet grass or soft turf could be damaged when brakes are used to turn sharply. To stop quickly, press both brake pedals together. Always lock the brakes together when transporting the machine.

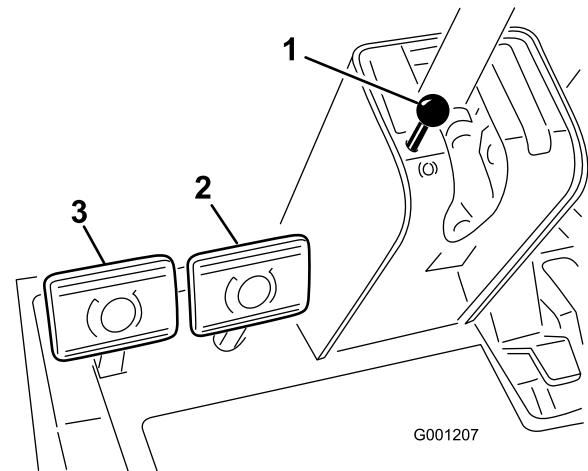

Figure 15

- | | |
|-----------------------|---------------------|
| 1. Parking brake knob | 3. Left brake pedal |
| 2. Right brake pedal | |

Parking Brake

Whenever the engine is shut off, the parking brake must be engaged to prevent accidental movement of the machine. To engage the parking brake, push the lock arm (Figure 16) on the left brake pedal so that it locks together with the right pedal. Next, push down

fully on both pedals and pull the parking brake knob out (Figure 15) then release the pedals. To release the parking brake, press both pedals until the parking brake knob retracts. Before starting the engine, however, the lock arm may be disengaged from the left brake pedal so both pedals work independently with each front wheel.

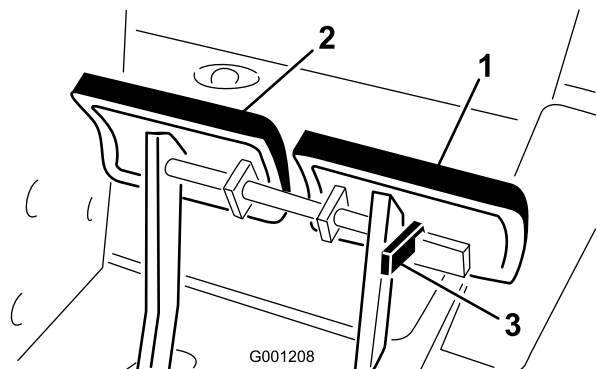

Figure 16

1. Left brake pedal
2. Right brake pedal
3. Lock arm

Traction Pedal

The traction pedal (Figure 17) has two functions: one is to make the machine move forward, the other is to make it move rearward. Using the heel and toe of the right foot, press the top of the pedal to move forward and the bottom of the pedal to move rearward. Ground speed is proportionate to how far the pedal is pressed. For maximum ground speed, the traction pedal must be fully depressed while throttle is in the Fast position. Maximum speed forward is 10 mph (approx.). To get maximum power under heavy load or when ascending a hill, have the throttle in the Fast position while pressing traction pedal slightly to keep the engine rpm high. When the engine rpm begins to decrease, release the traction pedal slightly to allow the rpm to increase.

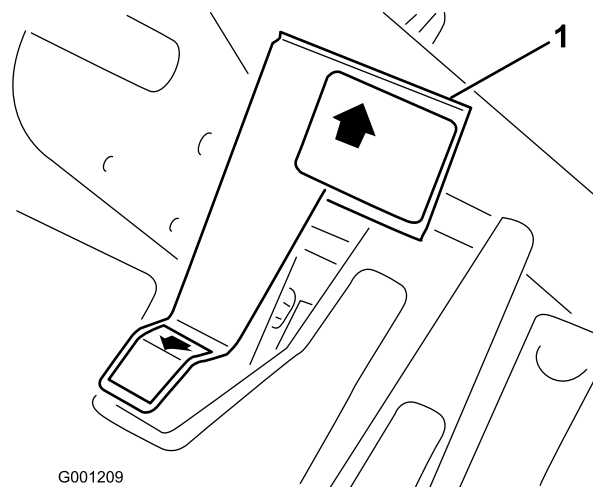

Figure 17

1. Traction pedal

Tilt Steering Control

The tilt steering control is a lever on the right side of the steering column (Figure 18). Pull the lever rearward to adjust the steering wheel to the desired fore or aft operating position and push the lever forward to lock the adjustment.

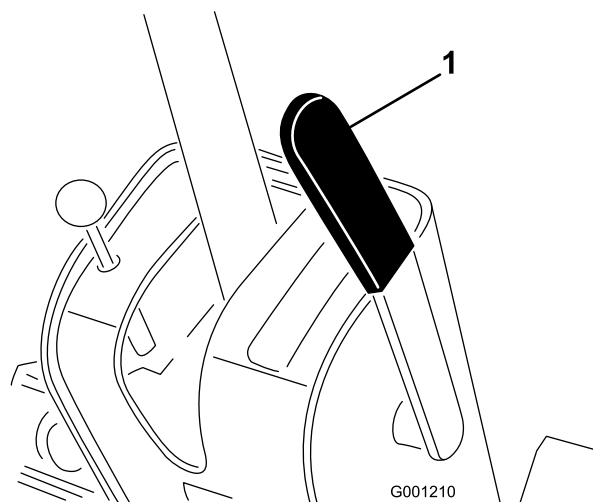

Figure 18

1. Tilt steering control



Never raise the deck while the blades are rotating. Contact with rotating blades can cause serious injury.

Hydraulic Lift Lever

The hydraulic lift lever (Figure 19) has three lever positions that actuate four operating modes; LIFT, LOWER, FLOAT & HOLD. To lower the deck, in preparation for mowing, move the lever forward and then allow the lever to freely return. This will allow the deck to drop at a controlled rate and enables the deck ground following float function. To raise the deck and hold it in the transport position, pull and hold the lift lever rearward until the deck has fully raised, then release the lever to allow it to return. The deck will now hold in the transport position. The deck must be raised when transporting between mowing locations. The deck should be lowered when not in use.

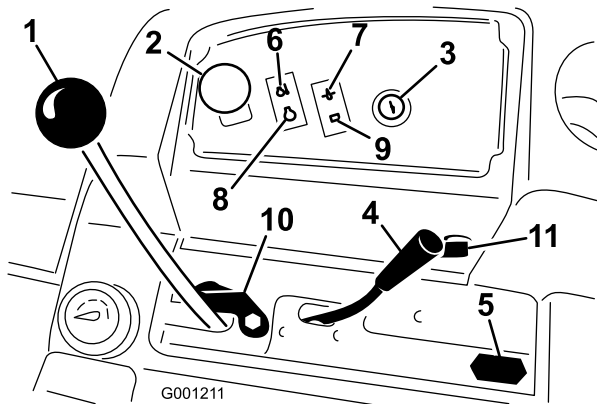

Figure 19

- | | |
|---|---------------------------|
| 1. Hydraulic Lift lever | 7. Oil pressure indicator |
| 2. PTO Switch | 8. Glow plug indicator |
| 3. Ignition switch | 9. Charge indicator |
| 4. Throttle | 10. Lift lever lock |
| 5. Hour meter | 11. Power point |
| 6. Engine coolant temperature indicator | |

PTO Switch

Pull up on the switch knob to engage the electric PTO clutch (Figure 19). Push down on the knob to disengage the electric PTO clutch. The only time the PTO switch should be in the engage position is when the implement is down in the operating position and ready to begin operation. If the operator leaves the seat when the PTO switch is engaged, the machine will shut down. To re-engage the PTO, push down and pull up on the knob.

Fuel Gauge

The fuel gauge (Figure 20) indicates quantity of fuel remaining in fuel tank.

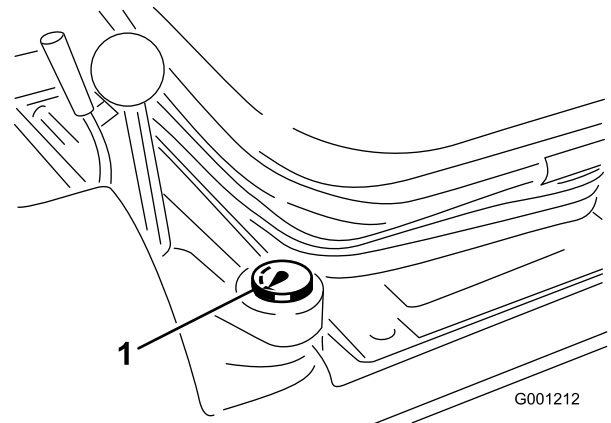

Figure 20

1. Fuel gauge

Ignition Switch

The ignition switch has three positions: Off, On/Preheat, and Start. (Figure 19).

Throttle

The throttle (Figure 19) is used to operate the engine at various speeds. Moving the throttle forward toward the Fast position increases the engine speed. Moving it rearward toward the Slow position decreases the engine speed. The throttle controls the speed of the blades and, in conjunction with traction pedal, controls ground speed of the machine. The detent is the high idle position.

Hour Meter

The hour meter (Figure 19) registers accumulated hours of engine operation.

Engine Coolant Temperature Warning Light

The temperature warning light (Figure 19) glows and the implement stops if the engine coolant temperature is high. If the machine is not stopped and the coolant temperature rises another 20° F, the engine will kill.

Glow Plug Indicator

When lit, indicates that the glow plugs are on (Figure 19).

Charge Indicator

Illuminates when the system charging circuit malfunctions (Figure 19).

Oil Pressure Warning Light

The oil pressure warning light (Figure 19) glows when the oil pressure in engine drops below a safe level. If low oil pressure ever occurs, stop the engine and determine the cause. Repair the damage before starting the engine again.

Lift Lever Lock

Lock the lift lever (Figure 19), in the raised position, when performing maintenance on the deck.

Specifications

Note: Specifications and design are subject to change without notice.

Length	82 inches
Width (Rear Wheels)	47 inches
Height without ROPS	50 inches
Height with ROPS	77 inches
Weight, Model 30344	1300 lb
Weight, Model 30345	1520 lb

Attachments/Accessories

A selection of Toro approved attachments and accessories are available for use with the machine to enhance and expand its capabilities. Contact your Authorized Service Dealer or Distributor or go to www.Toro.com for a list of all approved attachments and accessories.

Operation



This machine produces sound levels in excess of 85 dBA at the operators ear and can cause hearing loss through extended periods of exposure.

Wear hearing protection when operating this machine.



Adequate rear weight is necessary to prevent the rear wheels from leaving the ground. Do not stop suddenly while deck or implement is raised. Do not travel down hill with the deck or implement raised. If the rear wheel leaves the ground, steering is lost.

Checking the Engine Oil Level

Service Interval: Before each use or daily

The engine is shipped with oil in the crankcase; however, the oil level must be checked before and after the engine is first started.

The crankcase capacity is approximately 4 qt. (3.8 l) with the filter. Use high-quality engine oil that meets the following specifications:

- API Classification Level Required: CH-4, CI-4 or higher.
- Preferred oil: SAE 15W-40 (above 0°F)
- Alternate oil: SAE 10W-30 or 5W-30 (all temperatures)

Note: Toro Premium Engine oil is available from your distributor in either 15W-40 or 10W-30 viscosity. See the parts catalog for part numbers.

1. Park the machine on a level surface, lower the cutting deck, stop the engine and remove the key from the ignition switch. Open the hood.
2. Remove the dipstick (Figure 21), wipe it clean and reinstall the dipstick. Remove the dipstick and check the oil level. The oil level should be up to the Full mark on the dipstick.

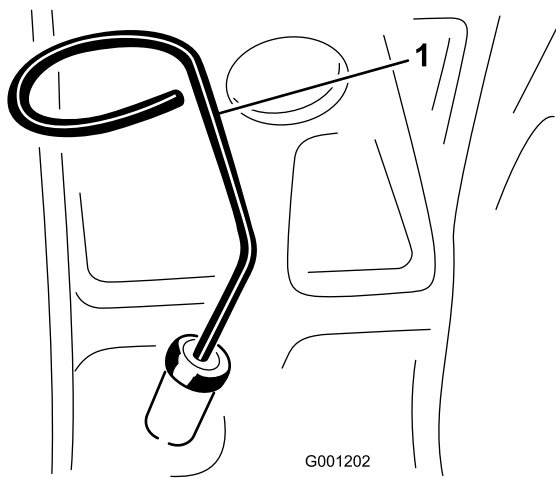

Figure 21

1. Dipstick

3. If the oil level is below the Full mark, remove the fill cap (Figure 22) and add oil until the level reaches the Full mark on the dipstick. **Do not overfill.**

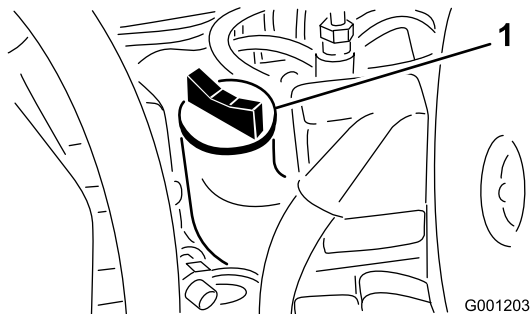

Figure 22

1. Oil fill

4. Install the oil fill cap and close the hood.

Checking the Cooling System

Clean debris off the screen and the radiator/oil cooler daily, more often if conditions are extremely dusty and dirty; refer to Cleaning the Radiator and the Screen.

The cooling system is filled with a 50/50 solution of water and permanent ethylene glycol anti freeze. Check the level of the coolant in the expansion tank at the beginning of each day before starting the engine. The capacity of the cooling system is 8 quarts (7.5 l).



If the engine has been running, pressurized hot coolant can escape when the radiator cap is removed and cause burns.

1. Check the level of the coolant in the expansion tank (Figure 23). The coolant level should be between the marks on the side of the tank.

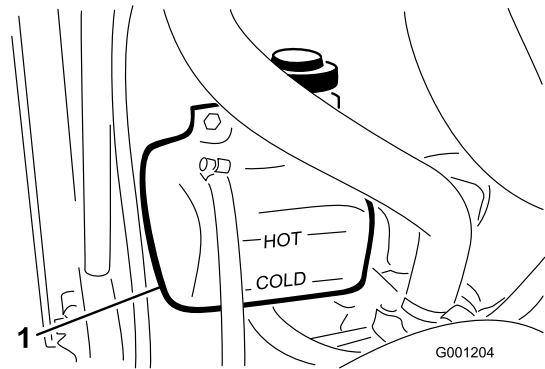

Figure 23

1. Expansion tank

2. If coolant level is low, remove expansion tank cap and replenish the system. **Do not overfill.**
3. Install expansion tank cap.

Checking the Hydraulic System

The machines reservoir is filled at the factory with approximately 5 quarts (4.7 l) of high quality hydraulic fluid. Check the level of the hydraulic fluid before the engine is first started and daily thereafter. The recommended replacement fluid is as follows:

Toro Premium Transmission/Hydraulic Tractor Fluid
(Available in 5 gallon pails or 55 gallon drums. See parts catalog or Toro distributor for part numbers.)

Alternate fluids: If the Toro fluid is not available, other petroleum-based Universal Tractor Hydraulic Fluids (UTHF) may be used provided its specifications fall within the listed range for all the following material properties and it meets industry standards. We do not recommend the use of synthetic fluid. Consult with your lubricant distributor to identify a satisfactory product Note: Toro will not assume responsibility for damage caused by improper substitutions, so use only products from reputable manufacturers who will stand behind their recommendation.

Note: Toro will not assume responsibility for damage caused by improper substitutions, so use only products from reputable manufacturers who will stand behind their recommendation.

Material Properties:

Viscosity, ASTM D445

cSt @ 40°C 55 to 62

cSt @ 100°C 9.1 to 9.8

Viscosity Index ASTM D2270 140 to 152

Pour Point, ASTM D97 -35°F to -46°F
Industry Specifications:

API GL-4, AGCO Powerfluid 821 XL, Ford New Holland FNHA-2-C-201.00, Kubota UDT, John Deere J20C, Vickers 35VQ25, and Volvo WB-101/BM

Note: Many hydraulic fluids are almost colorless, making it difficult to spot leaks. A red dye additive for the hydraulic system oil is available in 2/3 oz. (20 ml) bottles. One bottle is sufficient for 4-6 gal (15-22 l) of hydraulic oil. Order part number 44-2500 from your authorized Toro distributor.

1. Position machine on a level surface. Place all control in neutral position and start the engine. Run engine at lowest possible RPM to purge the system of air.

Do not engage the PTO. Cycle steering wheel several times fully to the left and right. Raise the deck to extend lift cylinders, aiming steering wheels straight forward and stop the engine.

2. Remove dipstick cap (Figure 24) from filler neck and wipe it with a clean rag. Screw dipstick cap finger-tight onto filler neck; then remove it and check level of fluid. If level is not within 1/2 inch (13 mm) from the groove in the dipstick, add enough high quality hydraulic fluid to raise level to groove mark. Do not overfill.

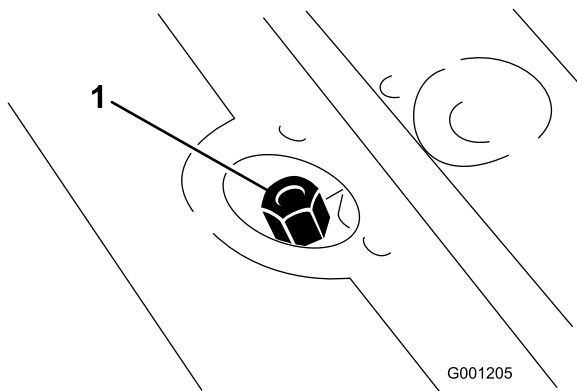

Figure 24

1. Hydraulic system reservoir fluid/add dipstick cap

3. Thread dipstick fill cap finger-tight onto filler neck. It is not recommended to tighten cap with a wrench.
4. Check all hoses and fittings for leaks.

Adding Fuel

Use only clean, fresh diesel fuel or biodiesel fuels with low (<500 ppm) or ultra low (<15 ppm) sulfur content. The minimum cetane rating should be 40. Purchase fuel in quantities that can be used within 180 days to ensure fuel freshness.

Fuel tank capacity: 12.8 US gallons (72 l)

Use summer grade diesel fuel (No. 2-D) at temperatures above 20° F (-7° C) and winter grade (No. 1-D or No. 1-D/2-D blend) below that temperature. Use of winter grade fuel at lower temperatures provides lower flash point and cold flow characteristics which will ease starting and reduce fuel filter plugging.

Use of summer grade fuel above 20° F (-7° C) will contribute toward longer fuel pump life and increased power compared to winter grade fuel.

Important: Do not use kerosene or gasoline instead of diesel fuel. Failure to observe this caution will damage the engine.



Fuel is harmful or fatal if swallowed. Long-term exposure to vapors can cause serious injury and illness.

- Avoid prolonged breathing of vapors.
- Keep face away from nozzle and gas tank or conditioner opening.
- Keep fuel away from eyes and skin.

Biodiesel Ready

This machine can also use a biodiesel blended fuel of up to B20 (20% biodiesel, 80% petrodiesel). The petrodiesel portion should be low or ultra low sulfur. Observe the following precautions:

- The biodiesel portion of the fuel must meet specification ASTM D6751 or EN14214.
- The blended fuel composition should meet ASTM D975 or EN590.
- Painted surfaces may be damaged by biodiesel blends.
- Use B5 (biodiesel content of 5%) or lesser blends in cold weather.
- Monitor seals, hoses, gaskets in contact with fuel as they may be degraded over time.
- Fuel filter plugging may be expected for a time after converting to biodiesel blends.
- Contact your distributor if you wish for more information on biodiesel.



In certain conditions, fuel is extremely flammable and highly explosive. A fire or explosion from fuel can burn you and others and can damage property.

- Fill the fuel tank outdoors, in an open area, when the engine is cold. Wipe up any fuel that spills.
- Never fill the fuel tank inside an enclosed trailer.
- Never smoke when handling fuel, and stay away from an open flame or where fuel fumes may be ignited by a spark.
- Store fuel in an approved container and keep it out of the reach of children. Never buy more than a 180-day supply of fuel.
- Do not operate without entire exhaust system in place and in proper working condition.



In certain conditions during fueling, static electricity can be released causing a spark which can ignite the fuel vapors. A fire or explosion from fuel can burn you and others and can damage property.

- Always place fuel containers on the ground away from your vehicle before filling.
- Do not fill fuel containers inside a vehicle or on a truck or trailer bed because interior carpets or plastic truck bed liners may insulate the container and slow the loss of any static charge.
- When practical, remove equipment from the truck or trailer and refuel the equipment with its wheels on the ground.
- If this is not possible, then refuel such equipment on a truck or trailer from a portable container, rather than from a fuel dispenser nozzle.
- If a fuel dispenser nozzle must be used, keep the nozzle in contact with the rim of the fuel tank or container opening at all times until fueling is complete.

1. Park the machine on a level surface.

2. Using a clean rag, clean area around fuel tank cap. Remove cap from the fuel tank (Figure 25).

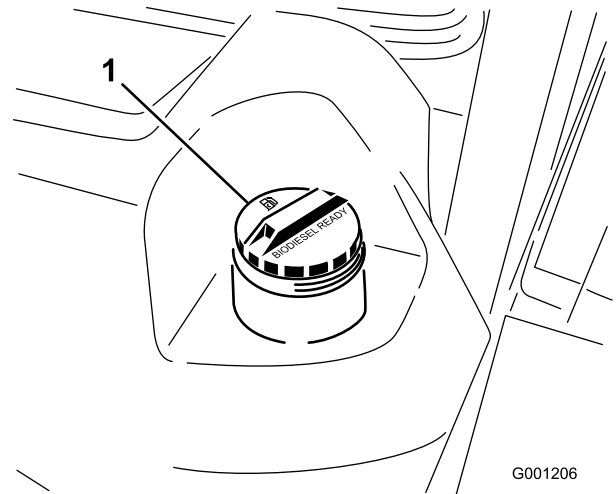

Figure 25

1. Fuel tank cap

3. Fill the tank until the level is to the bottom of the filler neck with diesel fuel.
4. Install fuel tank cap tightly after filling tank.

Note: If possible, fill the fuel tank after each use. This will minimize possible buildup of condensation inside the fuel tank.

Checking the Rear Axle Lubricant (Model 30345 only)

The rear axle has three separate reservoirs which use SAE 80W-90 wt. gear lube. Although the axle is shipped with lubricant from the factory, check the level before operating the machine.

1. Position the machine on a level surface.
2. Remove check plugs from axle and make sure lubricant is up to bottom of each hole. If level is low, remove fill plugs and add enough lubricant to bring the level up to the bottom of the check plug holes (Figure 26 and Figure 27).

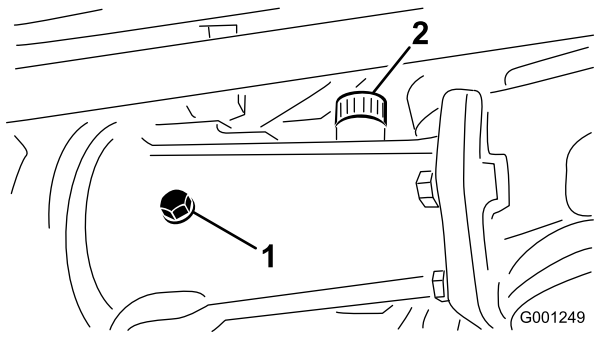

Figure 26

1. Check plug 2. Fill plug

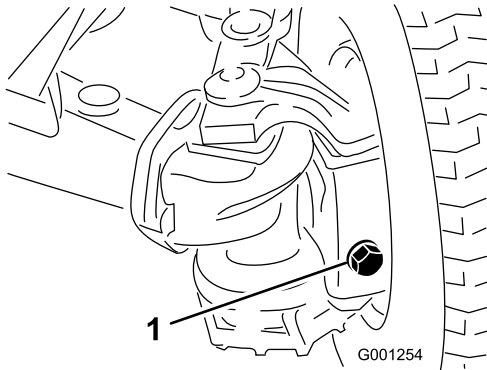

Figure 27

1. Fill/check plug (one on each end of axle)

Checking the Bidirectional Clutch Lubricant (Model 30345 only)

1. Position the machine on a level surface.
2. Rotate the clutch (Figure 28) so that the check plug (shown in the 12 o'clock position) is positioned at 4 o'clock.

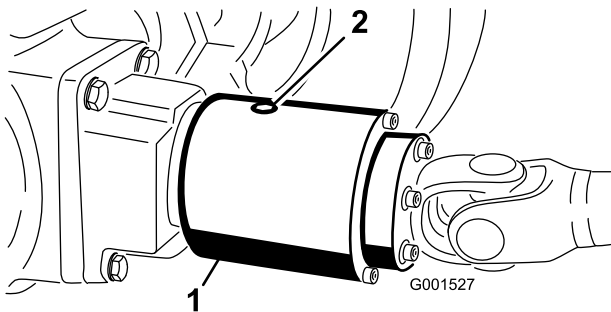

Figure 28

1. Bidirectional clutch 2. Check plug

3. Remove the check plug.

The fluid level should be up to the hole in the clutch. If the fluid level is low, add Mobil Fluid 424. The clutch should be approximately 1/3 full.

4. Install the check plug.

Note: Do not use engine oil (i.e. 10W30) in the bidirectional clutch. Anti-wear and extreme pressure additives will cause undesirable clutch performance.

Note: Determine the left and right sides of the machine from the normal operating position.

Using the Rollover Protection System (ROPS)



To avoid injury or death from rollover: keep the roll bar in the raised locked position and use the seat belt.

Ensure that the rear part of the seat is secured with the seat latch.



There is no rollover protection when the roll bar is in the down position.

- Lower the roll bar only when absolutely necessary.
- Do not wear the seat belt when the roll bar is in the down position.
- Drive slowly and carefully.
- Raise the roll bar as soon as clearance permits.
- Check carefully for overhead clearances (i.e. branches, doorways, electrical wires) before driving under any objects and do not contact them.
- Lower roll bar slowly so damage to hood does not occur.

Important: Lower the roll bar only when absolutely necessary.

1. To lower the roll bar, remove the hairpin cotter pins and remove the two pins (Figure 29).

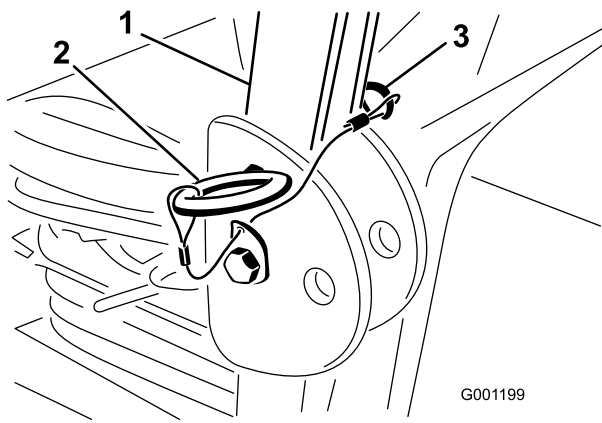

Figure 29

1. Roll bar
2. Pin
3. Hairpin cotter pin

2. Lower the roll bar to the down position.
3. Install the two pins and secure them with the hairpin cotter pins (Figure 29).
4. To raise the roll bar, remove the hairpin cotter pins and remove the two pins (Figure 29).
5. Raise the roll bar to the upright position and install the two pins and secure them with the hairpin cotter pins (Figure 29).

Important: Always use the seat belt when the roll bar is in the raised and locked position. Do not use the seat belt when the ROPS is in the lowered position.

Starting/Stopping the Engine

Important: The fuel system must be bled if any of the following situations have occurred: the initial start up of a new machine, the engine has ceased running due to lack of fuel, or maintenance has been performed upon fuel system components (i.e., filter replaced, separator serviced, etc).

1. Raise the ROPS up and lock into place, sit on the seat and fasten the seat belt.
2. Ensure that the parking brake is set and the PTO switch is in the Off position. Remove your foot from traction pedal and ensure that it is in neutral
3. Move the throttle control to the Fast position.
4. Turn the ignition switch to the On/Preheat position.
An automatic timer will control preheat for 6 seconds.
5. After preheating, turn the key to the Start position. **Crank the engine for no longer than 15 seconds.** Release the key when the engine starts. If

additional preheating is required, turn the key to the Off position, then to the On/Preheat position. Repeat this process as required.

6. Run the engine at idle speed or partial throttle until it warms up.

Note: Move the throttle to the Fast position when restarting a warm engine.

Important: When engine is started for the first time, or after an engine oil change, or overhaul of the engine, transmission, or axle, operate the machine in forward and reverse for one to two minutes. Also operate the lift lever and PTO lever to ensure proper operation of all parts. Turn the power steering wheel to the left and right to check the steering response. Then shut the engine off and check fluid levels, check for oil leaks, loose parts, and any other noticeable malfunctions.



Shut engine off and wait for all moving parts to stop before checking for oil leaks, loose parts or other malfunctions.

7. To stop engine, move the throttle control backward to the Slow position, move the PTO switch to the Off position and rotate ignition key to Off. Remove key from the switch to prevent accidental starting.

Bleeding the Fuel System

1. Park the machine on a level surface. Ensure that the fuel tank is at least half full.
2. Unlatch and raise the hood.



Under certain conditions, diesel fuel and fuel vapors are highly flammable and explosive. A fire or explosion from fuel can burn you and others and can cause property damage.

- Use a funnel and fill the fuel tank outdoors, in an open area, when the engine is off and is cold. Wipe up any fuel that spills.
- Do not fill the fuel tank completely full. Add fuel to the fuel tank until the level is to the bottom of the filler neck.
- Never smoke when handling fuel, and stay away from an open flame or where fuel fumes may be ignited by a spark.
- Store fuel in a clean, safety-approved container and keep the cap in place.

3. Open the air bleed screw on the fuel injection pump (Figure 30).

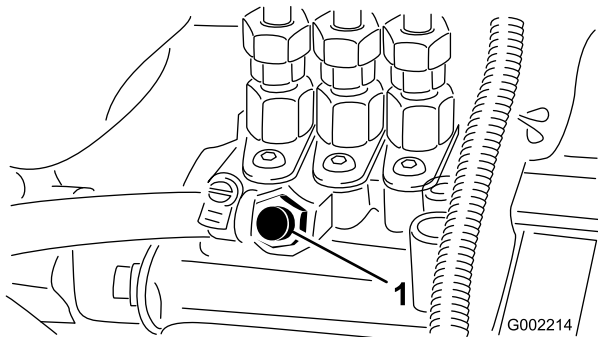

Figure 30

1. Fuel injection pump bleed screw

4. Turn the key in the ignition switch to the On position.

The electric fuel pump will begin operation, thereby forcing air out around the air bleed screw.

5. Leave the key in the On position until a solid stream of fuel flows out around the screw.
6. Tighten the screw and turn key to the Off position.

Note: Normally, engine should start after above bleeding procedures are followed. However, if engine does not start, air may be trapped between injection pump and injectors; refer to Bleeding Air From the Injectors.

Checking the Interlock System

The purpose of the safety interlock system is to prevent the engine from cranking or starting unless the traction

pedal is in neutral and the PTO switch is in the Off position. In addition, the engine will stop when:

- the PTO control is engaged with the operator off the seat;
- the traction pedal is depressed with the operator off the seat;
- the traction pedal depressed with the parking brake engaged.



If the safety interlock switches are disconnected or damaged the machine could operate unexpectedly causing personal injury.

- Do not tamper with the interlock switches.
- Check the operation of the interlock switches daily and replace any damaged switches before operating the machine.

1. Move PTO switch to Off position and remove foot from traction pedal so it is fully released.
2. Rotate the ignition key to Start. Engine should crank. If engine cranks, proceed to step 3. If engine does not crank, there may be a malfunction in the interlock system.
3. Raise off the seat and engage the PTO switch while the engine is running. The engine should stop within 2 seconds. If engine stops, the switch is operating correctly; thus, proceed to step 4. If engine does not stop, there is a malfunction in the interlock system.
4. Raise off the seat and depress the traction pedal while engine is running and the PTO lever is disengaged. The engine should stop within 2 seconds. If engine stops, the switch is operating correctly; thus, proceed to step 5. If engine does not stop, there is a malfunction in the interlock system.
5. Engage the parking brake. Depress the traction pedal while engine is running and the PTO lever is disengaged. The engine should stop within 2 seconds. If engine stops, the switch is operating correctly; thus, continue operation. If engine does not stop, there is a malfunction in the interlock system.

Pushing or Towing the Machine

In an emergency, the machine can be pushed or towed for a very short distance. However, Toro does not recommend this as standard procedure.

Important: Do not push or tow the machine faster than 2 to 3 mph because the transmission may be damaged. If the machine must be moved a considerable distance, transport it on a truck or trailer. Whenever the machine is pushed or towed, the by-pass valve must be open.

1. Loosen the knob and remove the access cover at the rear of the seat mounting plate (Figure 31).

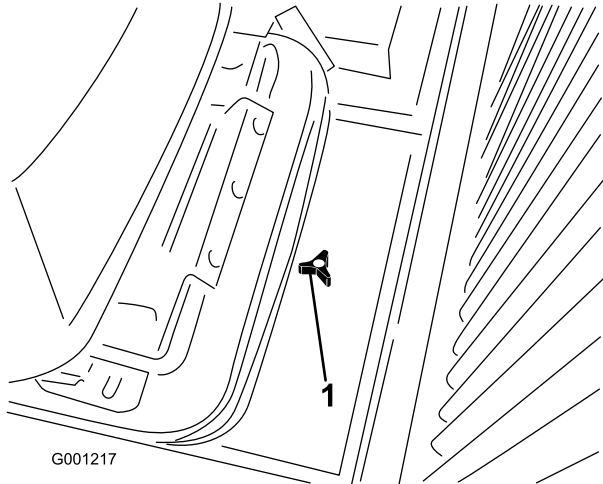

Figure 31

1. Access cover knob

2. Press and hold the pins located in the center of the 2 check valve assemblies in the top of the transmission (Figure 32) while pushing or towing the machine. Figure 32 is shown with seat and seat mounting plate removed.

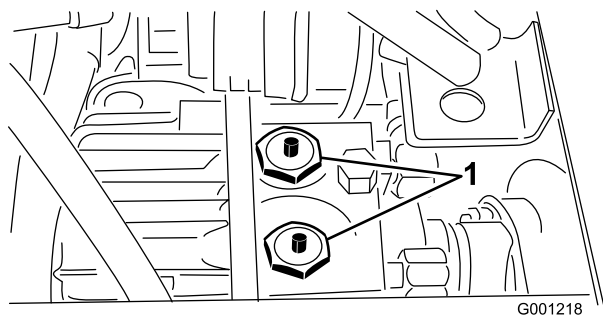

Figure 32

1. Transmission check valve by-pass pins (2)

3. Start the engine momentarily after the repairs are completed and make sure the pins are in the full disengaged (fully up) position.

Important: Running the machine with the by-pass valve open will cause the transmission to overheat.

4. Install the access cover.

Standard Control Module (SCM)

The Standard Control Module is a potted electronic device produced in a one size fits all configuration. The module uses solid state and mechanical components to monitor and control standard electrical features required for safe product operation.

The module monitors inputs including neutral, parking brake, PTO, start, backlap, and high temperature. The module energizes outputs including PTO, Starter, and ETR (energize to run) solenoid.

The module is divided into inputs and outputs. Inputs and outputs are identified by yellow LED indicators mounted on the printed circuit board.

The start circuit input is energized by 12 VDC. All other inputs are energized when the circuit is closed to ground. Each input has a LED that is illuminated when the specific circuit is energized. Use the input LED's for switch and input circuit troubleshooting.

Output circuits are energized by an appropriate set of input conditions. The three outputs include PTO, ETR, and START. Output LED's monitor relay condition indicating the presence of voltage at one of three specific output terminals.

Output circuits do not determine output device integrity so electrical troubleshooting includes output LED inspection and conventional device and wire harness integrity testing. Measure disconnected component impedance, impedance through wire harness (disconnect at SCM), or by temporarily test energizing the specific component.

The SCM does not connect to an external computer or hand held device, can not be re-programmed, and does not record intermittent fault troubleshooting data.

The decal on the SCM only includes symbols. Three LED output symbols are shown in the output box. All other LED's are inputs. The chart below identifies the symbols.

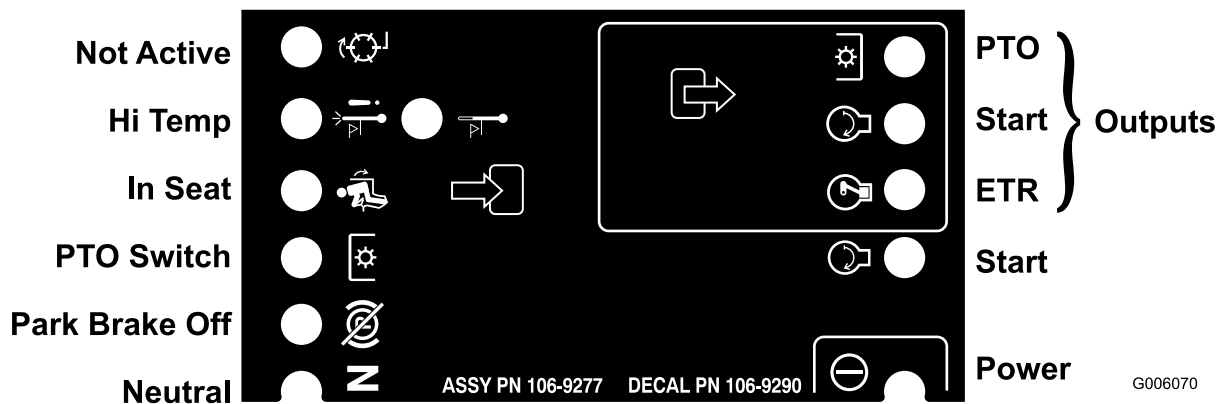

Figure 33

Here are the logical troubleshooting steps for the SCM device.

1. Determine the output fault you are trying to resolve (PTO, Start, or ETR).
2. Move key switch to the On position and ensure the red power LED is illuminated.
3. Move all input switches to ensure all LED's change state (Seat, Brake, Traction Pedal, PTO, and Start).
4. Position input devices at appropriate position to achieve the appropriate output. Use the following logic chart to determine the appropriate input condition.
5. If specific output LED is illuminated without appropriate output function, check output harness, connections, and component. Repair as required.
6. If specific output LED is not illuminated, check both fuses.
7. If specific output LED is not illuminated and inputs are in appropriate condition, install new SCM and determine if fault disappears.

Each row (across) in the logic chart below identifies input and output requirements for each specific product function. Product functions are listed in the left column. Symbols identify specific circuit condition including: energized to voltage, closed to ground, and open to ground.

Function	Inputs									Outputs		
	Power On	In Neutral	Start On	Brake On	PTO On	In Seat	Hi Temp Shutdown	Hi Temp Warning	Back Lap	Start	ETR	PTO
Start	—	—	+	Ä	Ä	—	Ä	Ä	N/A	+	+	Ä
Run (Off Unit)	—	—	Ä	Ä	Ä	Ä	Ä	Ä	N/A	Ä	+	Ä
Run (On Unit)	—	Ä	Ä	—	Ä	—	Ä	Ä	N/A	Ä	+	Ä
Mow	—	Ä	Ä	—	—	—	Ä	Ä	N/A	Ä	+	+
Hi Temp Warning	—		Ä				Ä	— (A)	N/A	+	+	Ä
Hi Temp Shutdown	—		Ä				—		N/A	Ä	Ä	Ä

(-) Indicates a circuit closed to ground. - LED ON

(Ä) Indicates a circuit open to ground or de-energized - LED OFF

(+) Indicates an energized circuit (clutch coil, solenoid, or start input) LED ON.

A Blank indicates a circuit that is not involved with the logic.

(A) PTO input must be re-initiated after engine cool down (cycle key on-off)

N/A Not applicable

To troubleshoot, turn on the key without starting the engine. Identify the specific function that does not work and work across the logic chart. Inspect the condition of each input LED's to ensure it matches the logic chart.

If the input LED's are correct, check the output LED. If the output LED is illuminated but the device is not energized, measure available voltage at the output device, continuity of the disconnected device, and potential voltage on the ground circuit (floating ground). Repairs will vary depending on your findings.

Operating Tips

- Practice driving the machine before initial operation because it has a hydrostatic transmission and its characteristics are different than some turf maintenance machines. Some points to consider when operating the machine and deck are the transmission, engine speed, load on the cutting blades, and the importance of the brakes.
- To maintain enough power for the machine and deck while mowing, regulate traction pedal to keep engine rpm high and somewhat constant. A good rule to follow is: decrease ground speed as the load on the cutting blades increases; and increase ground speed as load on the blades decreases. This allows the engine, working with the transmission, to sense the proper ground speed while maintaining high

blade tip speed necessary for good quality-of-cut. Therefore, allow traction pedal to move upward as engine speed decreases, and depress pedal slowly as speed increases. By comparison, when driving from one work area to another-with no load and deck raised-have throttle in Fast position and depress traction pedal slowly but fully to attain maximum ground speed.

- Another characteristic to consider is the operation of the brakes. The brakes can be used to assist in turning the machine; however, use them carefully, especially on soft or wet grass because the turf may be torn accidentally. The brakes can be used to control the direction of the deck when trimming along fences or similar objects. The other benefit of the brakes is to maintain traction. For example; in some slope conditions, the uphill wheel slips and loses traction. If this situation occurs, depress uphill brake pedal gradually and intermittently until the uphill wheel stops slipping; thus, increasing traction on the downhill wheel. If independent braking is not desired, engage the lever on left brake pedal with right pedal. This provides simultaneous braking at both wheels.
- Before stopping the engine, disengage all controls and move the throttle to the Slow position. Moving the throttle to the Slow position reduces high engine speed, noise, and vibration. Turn the ignition key to the Off position to stop the engine.

Maintenance

Recommended Maintenance Schedule(s)

Maintenance Service Interval	Maintenance Procedure
After the first 10 hours	<ul style="list-style-type: none"> • Check the service brake adjustment. • Check the alternator belt tension. • Check PTO belt tension. • Change the hydraulic oil filter. Do not exceed 10 hours or you will damage the hydraulic system • Torque wheel lug nuts.
After the first 50 hours	<ul style="list-style-type: none"> • Change the engine oil and filter. • Check the service brake adjustment. • Check PTO belt tension.
Before each use or daily	<ul style="list-style-type: none"> • Check the engine oil level.
Every 50 hours	<ul style="list-style-type: none"> • Grease the bearings and bushings. • Check battery cable connections. • Check the battery electrolyte level. • Lubricate the brake cables.
Every 150 hours	<ul style="list-style-type: none"> • Change the engine oil and filter.
Every 200 hours	<ul style="list-style-type: none"> • Check steering cylinder mounting bolt torque. (Model 30345 only) • Check the rear wheel toe-in. • Inspect cooling system hoses. • Check the alternator belt tension • Check PTO belt condition and tension. • Check PTO clutch gap adjustment. • Change the hydraulic oil filter • Torque wheel lug nuts.
Every 400 hours	<ul style="list-style-type: none"> • Grease the transmission bypass pins. • Grease the rear axle bearings. • Service the air cleaner. • Replace the fuel filter canister. • Drain and clean the fuel tank. • Check the fuel lines and connections. • Change the rear axle lubricant. • Change the bidirectional clutch lubricant (Model 30345 only).
Every 1,500 hours	<ul style="list-style-type: none"> • Replace moving hoses • Flush and replace cooling system fluid. • Replace the hydraulic oil.



If you leave the key in the ignition switch, someone could accidentally start the engine and seriously injure you or other bystanders.

Remove the key from the ignition before you do any maintenance.

Daily Maintenance Checklist

Duplicate this page for routine use.

Maintenance Check Item	For the week of:						
	Mon.	Tues.	Wed.	Thurs.	Fri.	Sat.	Sun.
Check Safety Interlock Operation							
Check Grass Deflector in Down Position							
Check Brake Operation							
Check Fuel Level							
Check Engine Oil Level							
Check Cooling System Fluid Level							
Check Drain Water/Fuel Separator							
Check Air Filter Restriction Indicator ³							
Check Radiator & Screen for Debris							
Check Unusual Engine Noises ¹							
Check Unusual Operating Noises							
Check Transmission Oil Level							
Check Hydraulic Hoses for Damage							
Check Fluid Leaks							
Check Tire Pressure							
Check Instrument Operation							
Check Condition of Blades							
Lubricate All Grease Fittings ²							
Touch-up Damaged Paint							

1. Check glow plug and injector nozzles, if hard starting, excess smoke or rough running is noted.
2. Immediately after every washing, regardless of the interval listed.
3. If indicator shows red

Important: Refer to your *Engine Operator's Manual* for additional maintenance procedures.

Notation for Areas of Concern		
Inspection performed by:		
Item	Date	Information

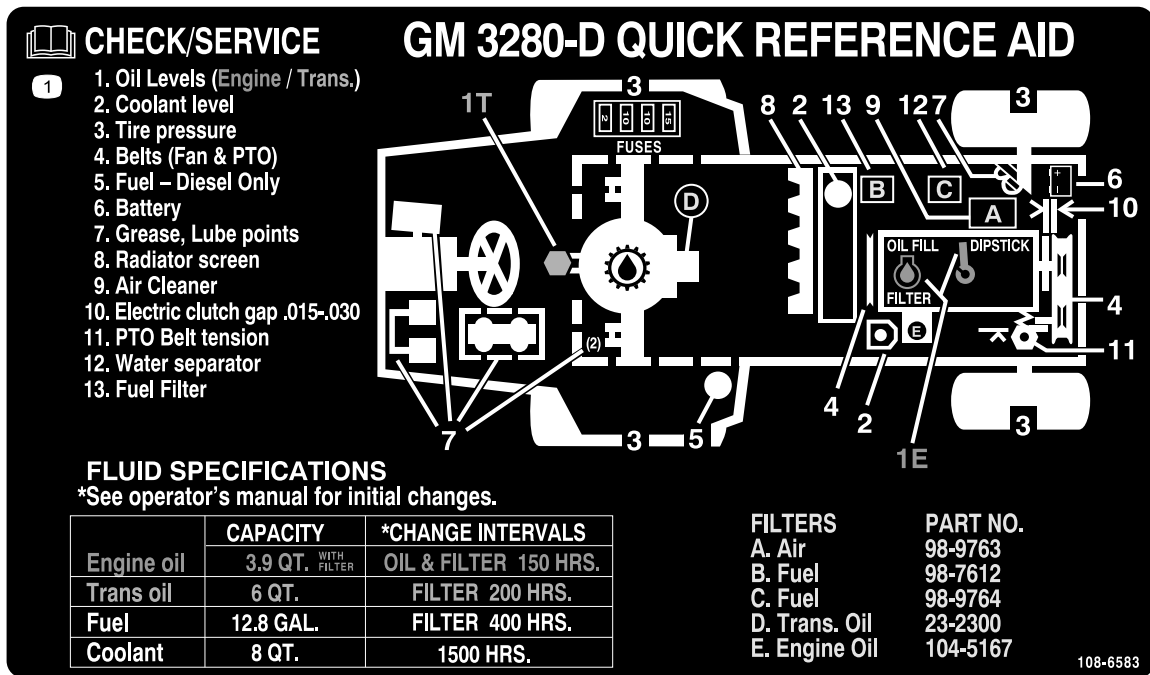

Figure 34
Service Interval Chart

Lubrication

Greasing the Bearings and Bushings

Service Interval: Every 50 hours—Grease the bearings and bushings.

Every 400 hours—Grease the transmission bypass pins.

Every 400 hours—Grease the rear axle bearings. (Or yearly, whichever comes first)

The machine has grease fittings that must be lubricated regularly with No. 2 General Purpose Lithium Base Grease. If machine is operated under normal conditions, lubricate all bearings and bushings after every 50 hours of operation. Bearings and bushings must be lubricated daily when operating conditions are extremely dusty and dirty. Dusty and dirty operating conditions could cause dirt to get into the bearings and bushings, resulting in accelerated wear. Lubricate grease fitting immediately after every washing, regardless of interval specified.

Apply a liberal coating of grease to the check valve pins once each year (Figure 35). Also grease the bearings in the rear axle every 500 hours.

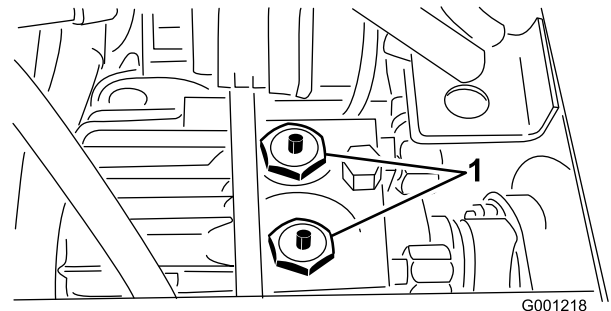

Figure 35

1. Transmission check valve by-pass pins (2)

- Wipe grease fitting clean so foreign matter cannot be forced into the bearing or bushing.
- Pump grease into the bearing or bushing.
- Wipe up excess grease.

The bearing and bushing lubrication points are as follows:

- PTO universal shaft (Figure 36)

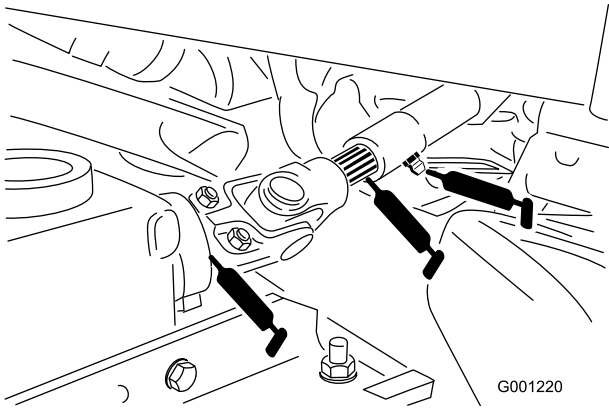

Figure 36

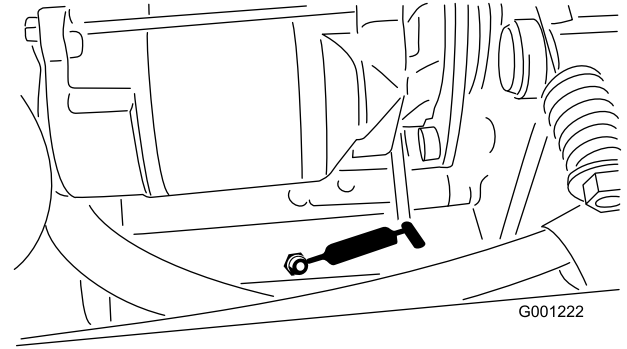

Figure 39

- Lift arm pivot bushings (Figure 37)

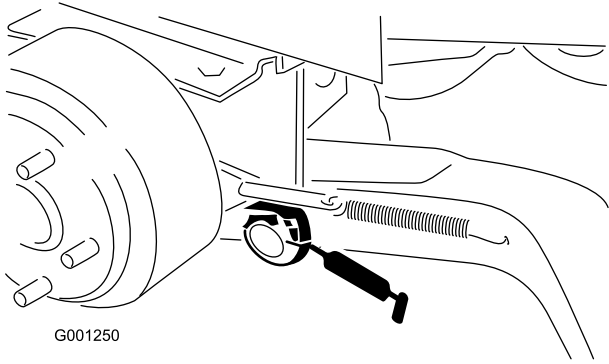

Figure 37

- Rear PTO bearing (Figure 39)
- Transmission neutral shaft (Figure 40)

Note: 2 Wheel Drive Only

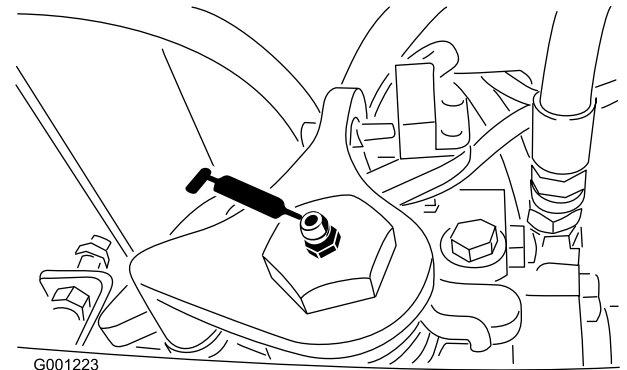

Figure 40

- Brake pivot bushings (Figure 38)

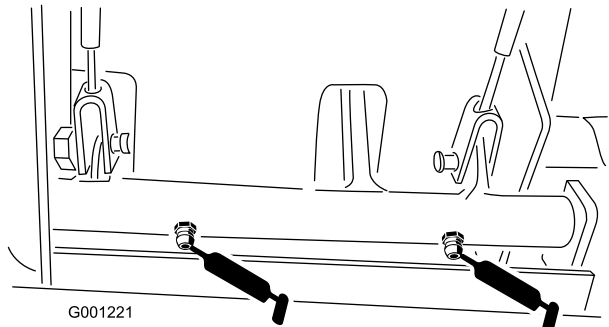

Figure 38

- Rear wheel spindle bushings (Figure 41)

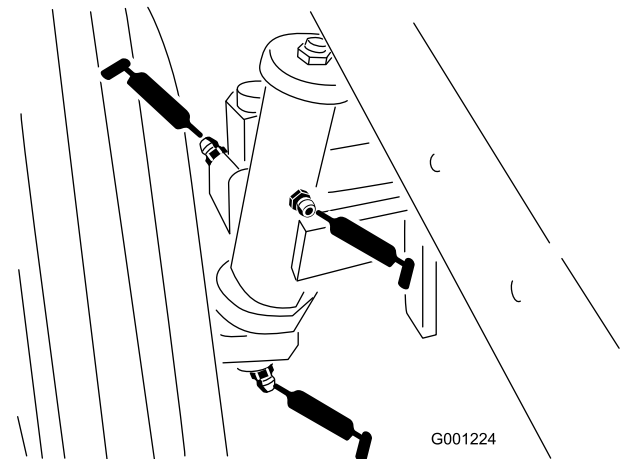

Figure 41

- Brake cables (drive wheel and brake pedal ends) (Figure 38)
- PTO tension pivot (Figure 39)

- Steering plate bushings (Figure 42)

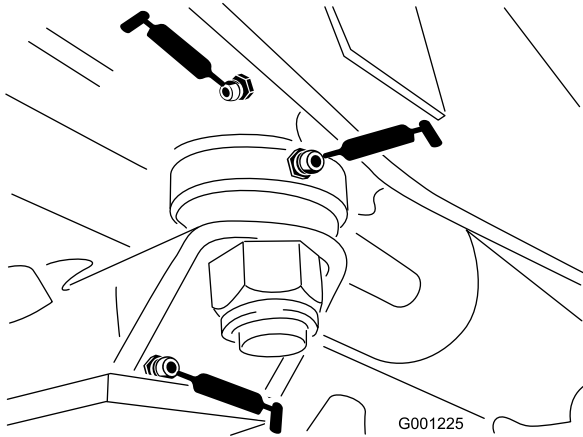

Figure 42

- Axle pin bushing (Figure 42)
- Drive shaft (3) (Figure 43)

Note: 4 Wheel Drive Only

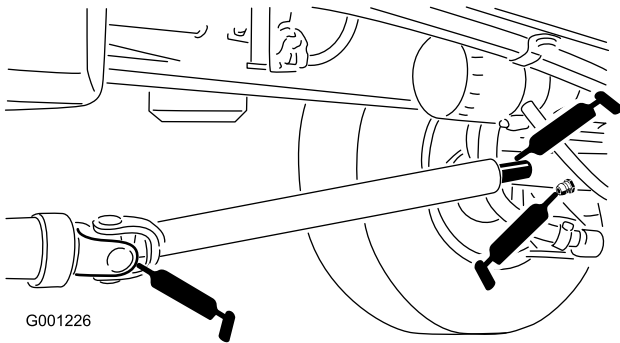

Figure 43

- Tie rod ends (2) (Figure 44)

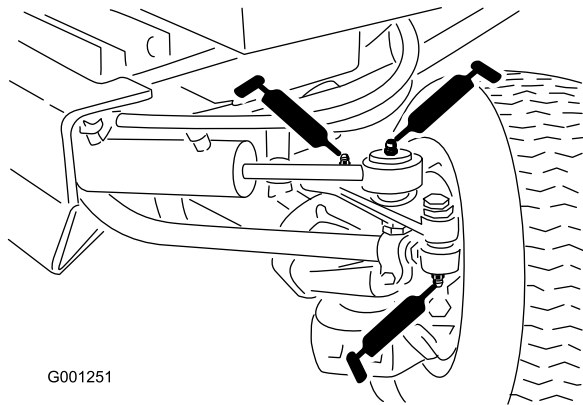

Figure 44

- Cylinder rod ends (2) (Figure 44)
- Steering pivots (2) (Figure 44)
- Axle pivot pin (Figure 44)

Note: Bearings rarely fail from defects in materials or workmanship. The most common reason for failure

is moisture and contamination working its way past the protective seals. Bearings that are greased will rely upon regular maintenance to purge harmful debris from the bearing area. Sealed bearings rely on an initial fill of special grease and a robust integral seal to keep contaminants and moisture out of the rolling elements.

The sealed bearings require no lubrication or short term maintenance. This minimizes routine service required and reduces the potential of turf damage due to grease contamination. These sealed bearing packages will provide good performance and life under normal use, but periodic inspections of bearing condition and seal integrity should be conducted to avoid downtime. These bearings should be inspected seasonally and replaced if damaged or worn. Bearings should operate smoothly with no detrimental characteristics such as high heat, noise, looseness or indications of corrosion (rust).

Due to the operating conditions these bearing/seal packages are subject to (i.e. sand, turf chemicals, water, impacts, etc.) they are considered normal wear items. Bearings that fail due to causes other than defects in materials or workmanship are typically not covered under warranty.

Note: Bearing life can be negatively affected by improper wash down procedures. Do not wash down the unit when it is still hot and avoid directing high-pressure or high volume spray at the bearings.

Engine Maintenance

Note: Determine the left and right sides of the machine from the normal operating position.

General Air Cleaner Maintenance

- Check the air cleaner body for damage which could possibly cause an air leak. Replace a damaged air cleaner body. Check the whole intake system for leaks, damage, or loose hose clamps.
- Service the air cleaner filter when the air cleaner indicator (Figure 45) shows red or every 400 hours (more frequently in extremely dusty or dirty conditions). Do not over service the air filter.

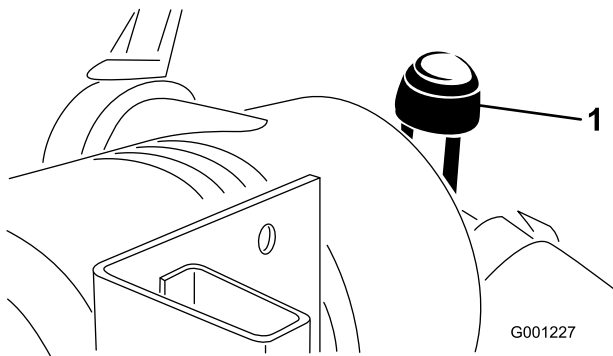

Figure 45

1. Air cleaner indicator

- Be sure the cover is seated correctly and seals with the air cleaner body.

Servicing the Air Cleaner

Service Interval: Every 400 hours

1. Pull the latch outward and rotate the air cleaner cover counter-clockwise (Figure 46).

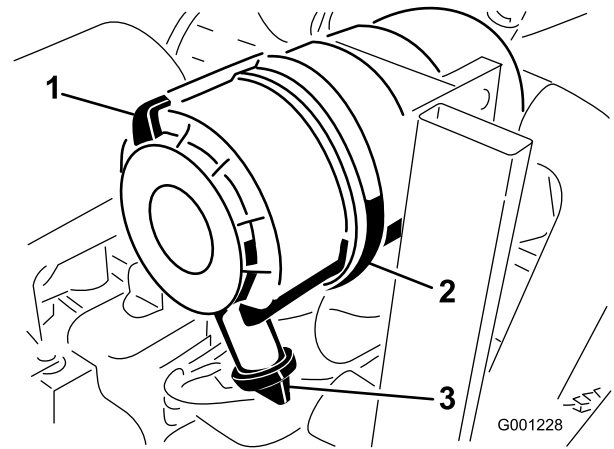

Figure 46

1. Air cleaner latch
2. Air cleaner cover
3. Rubber outlet valve

2. Remove the cover from the air cleaner body (Figure 46).
3. Before removing the filter, use low pressure air (40 psi, clean and dry) to help remove large accumulations of debris packed between outside of primary filter and the canister.

This cleaning process prevents debris from migrating into the intake when the primary filter is removed.

Important: Avoid using high pressure air which could force dirt through the filter into the intake tract.

4. Remove and replace the primary filter (Figure 47).

Important: Do not clean the used element to avoid damage to the filter media.

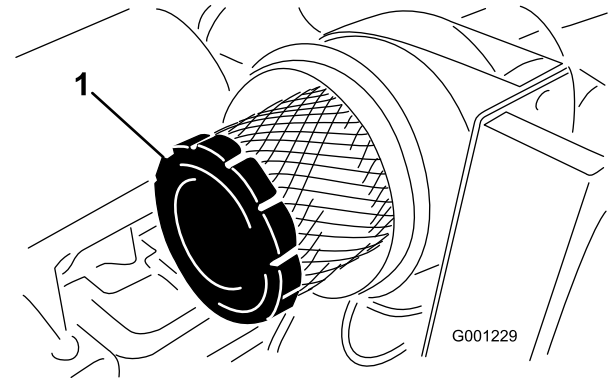

Figure 47

1. Filter

5. Inspect the new filter for shipping damage, checking the sealing end of the filter and the body.

Important: Do not use a damaged element.

6. Insert the new filter by applying pressure to the outer rim of the element to seat it in the canister.

Important: Do not apply pressure to the flexible center of the filter.

7. Clean the dirt ejection port located in the removable cover, as follows:
 - A. Remove the rubber outlet valve from the cover.
 - B. Clean the cavity.
 - C. Replace the outlet valve.
8. Install the cover orienting the rubber outlet valve in a downward position—between approximately 5:00 to 7:00 when viewed from the end (Figure 46).
9. Reset the indicator (Figure 45) if showing red.

Changing the Engine Oil And Filter

Service Interval: After the first 50 hours

Every 150 hours

If possible, run engine just before changing oil because warm oil flows better and carries more contaminants than cold oil.

1. Position the machine on a level surface.
2. Open the hood.
3. Set a drain pan under the oil pan and in line with the drain plug (Figure 48).

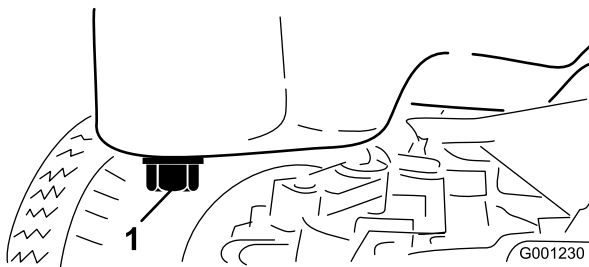

Figure 48

1. Drain plug

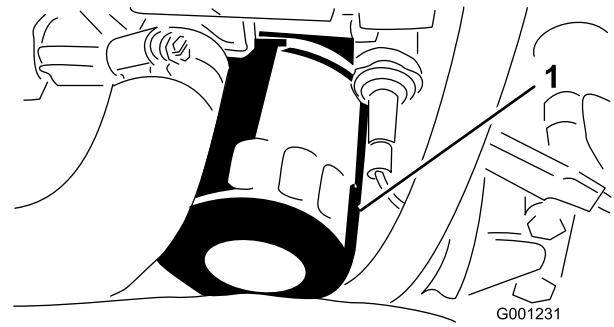

Figure 49

1. Oil filter

7. After the oil is drained, install the drain plug and wipe up any oil that is spilled.
8. Fill the crankcase with oil; refer to Checking the Engine Oil Level

Fuel System Maintenance

Note: Refer to Filling the Fuel Tank for proper fuel recommendations.

Servicing the Water Separator

Service Interval: Every 400 hours

Drain water or other contaminants from water separator (Figure 50) daily. Replace filter canister after every 400 hours of operation.

1. Place a clean container under the fuel filter.
2. Loosen the drain plug on the bottom of the filter canister.

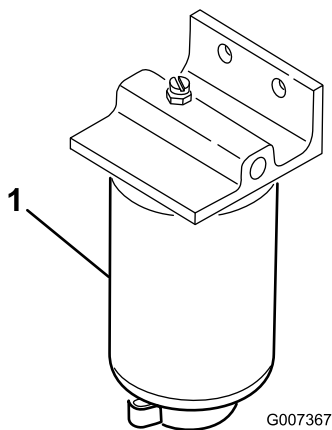

Figure 50

1. Water separator filter canister

3. Clean the area where the filter canister mounts.
4. Remove the filter canister and clean the mounting surface.
5. Lubricate the gasket on the filter canister with clean oil.
6. Install the filter canister by hand until the gasket contacts mounting surface, then rotate it an additional 1/2 turn.
7. Tighten the drain plug on the bottom of the filter canister.

Cleaning the Fuel Tank

Service Interval: Every 400 hours—Drain and clean the fuel tank. (Or yearly, whichever comes first)

Drain and clean tank if fuel system becomes contaminated or if machine is to be stored for an

extended period. Use clean diesel fuel to flush out the tank.

Fuel Lines and Connections

Service Interval: Every 400 hours (Or yearly, whichever comes first)

Inspect the fuel lines for deterioration, damage, or loose connections.

Bleeding Air From the Injectors

Note: This procedure should be used only if fuel system has been purged of air through normal priming procedures and engine will not start; refer to Bleeding the Fuel System.

1. Loosen the pipe connection to the No. 1 injector nozzle and holder assembly at the injection pump (Figure 51).

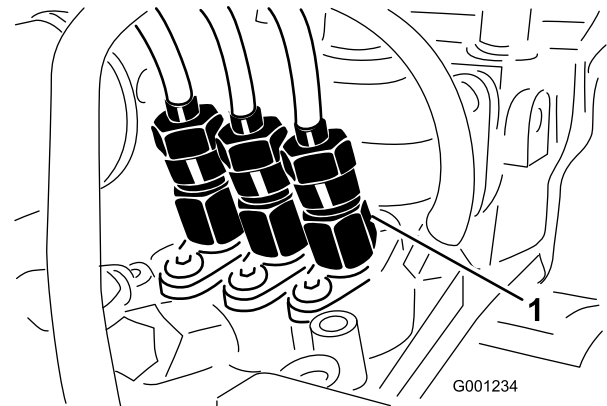

Figure 51

1. No. 1 injector nozzle
-
2. Move the throttle to the Fast position.
 3. Turn the ignition key the Start position and watch the fuel flow around the connector.
 4. Turn the key to the Off position when it attains a solid flow.
 5. Tighten the pipe connector securely.
 6. Repeat this procedure for the remaining nozzles.

Electrical System Maintenance

Servicing the Battery

Service Interval: Every 50 hours—Check battery cable connections.

Every 50 hours—Check the battery electrolyte level.

Warning

CALIFORNIA

Proposition 65 Warning

Battery posts, terminals, and related accessories contain lead and lead compounds, chemicals known to the State of California to cause cancer and reproductive harm.

Wash hands after handling.

Maintain the battery electrolyte level and keep the top of the battery clean. If you store the machine in a location where temperatures are extremely high, the battery will run down more rapidly than if the machine is stored in a location where temperatures are cool.

Check the electrolyte level every 50 operating hours or, if the machine is in storage, every 30 days.

Maintain the cell level with distilled or demineralized water. Do not fill the cells above the bottom of the split ring inside each cell.



Battery electrolyte contains sulfuric acid which is a deadly poison and causes severe burns.

- **Do not drink electrolyte and avoid contact with skin, eyes, or clothing. Wear safety glasses to shield your eyes and rubber gloves to protect your hands.**
- **Fill the battery where clean water is always available for flushing the skin.**

Keep the top of the battery clean by washing it periodically with a brush dipped in ammonia or bicarbonate of soda solution. Flush the top surface with water after cleaning it. Do not remove the fill caps while cleaning the battery.

The battery cables must be tight on the terminals to provide good electrical contact.

If corrosion occurs at the terminals, disconnect the cables, negative (-) cable first, and scrape the clamps and terminals separately. Reconnect the cables, positive (+) cable first, and coat the terminals with petroleum jelly.



Battery terminals or metal tools could short against metal machine components causing sparks. Sparks can cause the battery gasses to explode, resulting in personal injury.

- **When removing or installing the battery, do not allow the battery terminals to touch any metal parts of the tractor.**
- **Do not allow metal tools to short between the battery terminals and metal parts of the machine.**



Incorrect battery cable routing could damage the machine and cables causing sparks. Sparks can cause the battery gasses to explode, resulting in personal injury.

- **Always disconnect the negative (black) battery cable before disconnecting the positive (red) cable.**
- **Always connect the positive (red) battery cable before connecting the negative (black) cable.**

Storing the Battery

If the machine will be stored more than 30 days, remove the battery and charge it fully. Either store it on the shelf on the machine. Leave the cables disconnected if it is stored on the machine. Store the battery in a cool atmosphere to avoid quick deterioration of the charge in the battery. To prevent the battery from freezing, make sure it is fully charged. The specific gravity of a fully charged battery is 1.265-1.299.

Servicing the Wiring Harness

Prevent corrosion of wiring terminals by applying Grafo 112X (Skin-over) grease, Toro Part No. 505-47, to the inside of all harness connectors whenever the harness is replaced.

Important: Whenever working with the electrical system, always disconnect the battery cables,

negative (-) cable first, to prevent possible wiring damage from short-outs.

Accessing the Fuses

The fuses are located under the control panel (Figure 52).

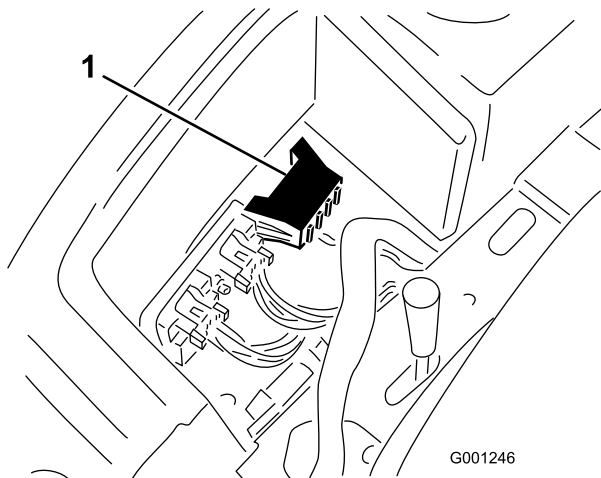

Figure 52

1. Fuse block

Drive System Maintenance

Changing the Rear Axle Lubricant (Model 30345 only)

Service Interval: Every 400 hours

1. Position the machine on a level surface.
2. Clean the area around the 3 drain plugs, 1 on each end and 1 in the center (Figure 53).

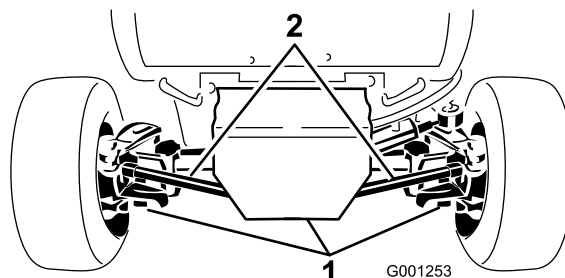

Figure 53

1. Drain plugs (3)
3. Remove the plugs allowing the oil to drain into drain pans.
4. After the oil is drained, apply thread locking compound on the drain plug threads and install them in axle.
5. Fill the axle with lubricant; refer to Checking the Rear Axle Lubricant.

Checking Steering Cylinder Bolt Torque (Model 30345 only)

Service Interval: Every 200 hours (Model 30345 only)

1. Position the machine on a level surface.
2. Check the torque on the steering cylinder mounting bolts (Figure 54). Torque should be 48 to 60 ft-lb.

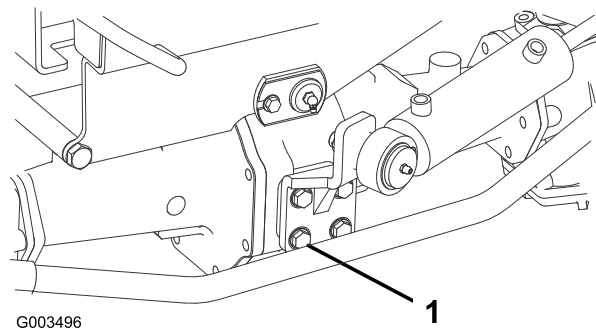

Figure 54

1. Mounting bolt (4)

Changing the Bidirectional Clutch Lubricant (Model 30345 only)

Service Interval: Every 400 hours

1. Position the machine on a level surface.
2. Clean the area around the check plug on the bidirectional clutch.
3. Rotate the clutch so that the check plug is positioned downward (Figure 55).

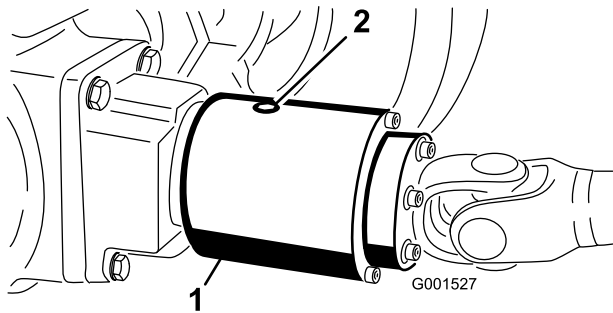

Figure 55

1. Bidirectional clutch
2. Check plug

4. Remove the check plug allowing all lubricant to flow into a drain pan.
5. Rotate the clutch so that the check plug is positioned at 4 O'clock.
6. Add Mobil Fluid 424 until the lubricant level is up to the hole in the clutch. The clutch should be approximately 1/3 full.
7. Install the check plug.

Note: Do not use engine oil (i.e. 10W30) in the bidirectional clutch. Anti-wear and extreme pressure additives will cause undesirable clutch performance.

Adjusting the Traction Drive for Neutral

If the machine moves when the traction pedal is in the neutral position, adjust the traction cam.

1. Park the machine on a level surface and turn the engine off.
2. Raise one front wheel and one rear wheel off of the floor and place support blocks under the frame.



If the machine is not supported adequately, it may accidentally fall, injuring anyone under the machine.

One front wheel and one rear wheel must be raised off of the ground or the machine will move during adjustment.

3. Loosen the retaining screw on the opposite side of the traction adjustment cam (Figure 56).

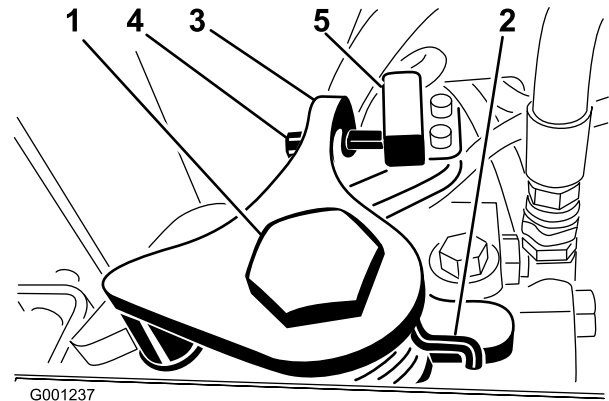

Figure 56

1. Traction adjustment cam
2. Retaining screw
3. Neutral return arm
4. Adjusting screw
5. Neutral return switch

4. Start the engine and rotate the cam hex forward until the front wheel starts to rotate, then rotate the hex cam backward until the front wheel starts to rotate. Determine the mid position of the neutral span and tighten the retaining screw. Perform this operation at low speed idle and at high engine speed.



The engine must be running so a final adjustment of the traction adjustment cam can be performed. Contact with hot or moving parts can result in personal injury.

Keep hands, feet, face, and other body parts away from the muffler, other hot parts of the engine, and other rotating parts.

5. Tighten the screw securing the adjustment.
6. Stop the engine.
7. Adjust the screw on the neutral return arm (Figure 56) until the gap between the end of the screw and the switch contact is .090–.120 inch.

- Remove the support blocks and lower the machine to the shop floor.
- Test drive the machine to make sure it does not move when the traction pedal is in neutral.

Adjusting Rear Wheel Toe-in

Service Interval: Every 200 hours—Check the rear wheel toe-in.

Model 30344

The rear wheels should not toe-in or toe-out when they are adjusted correctly. To check the rear wheel toe-in, measure the center-to-center distance at wheel hub height, in front and in back of the rear tires. If the wheels toe-in or toe-out, an adjustment is required.

- Rotate the steering wheel so rear wheels are straight ahead.
- Loosen the jam nuts on both tie rods. Adjust both tie rods until center-to-center distance at front and back of rear wheels is the same (Figure 57).
- When rear wheels are adjusted correctly, tighten jam nuts against tie rods.

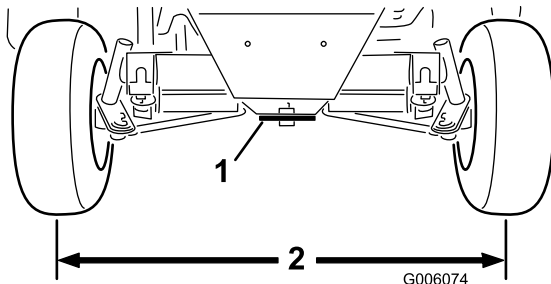

Figure 57

- Steering plate
- Same dimension at front and rear of wheels

Model 30345

The rear wheels should not toe-in or toe-out when they are adjusted correctly. To check the rear wheel toe-in, measure the center-to-center distance at wheel hub height, in front and in back of the rear tires. If the wheels toe-in or toe-out, an adjustment is required.

- Rotate the steering wheel so rear wheels are straight ahead.
- Remove nuts securing one tie rod ball joint to the mounting bracket on the axle and disconnect the ball joint from the axle (Figure 58).

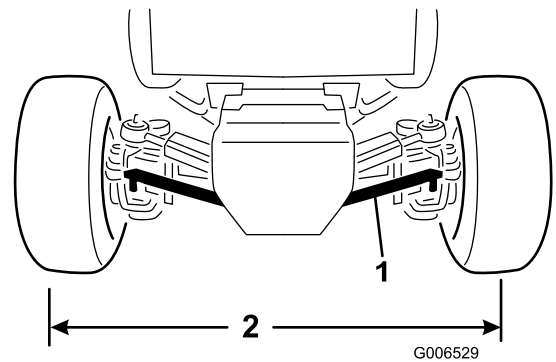

Figure 58

- Tie rod
- Same dimension at front and rear of wheels

- Loosen the screw on the tie rod clamp.
- Rotate the tie rod ball joint in or out until the center-to-center distance at front and back of rear wheels is the same (Figure 58).
- Install the ball joint to the mounting bracket and check the wheel toe-in.
- After attaining desired adjustment, tighten the screw on the tie rod clamp and secure the ball joint to the mounting bracket.

Adjusting Steering Stops (Model 30345 only)

The rear axle steering stops help prevent over travel of the steering cylinder in case of impact on rear wheels. The stops should be adjusted so there is .090 inch clearance between the bolt head and the knuckle on the axle when the steering wheel is completely turned left or right.

- Thread the bolts in or out until the .090 inch clearance is attained (Figure 59).

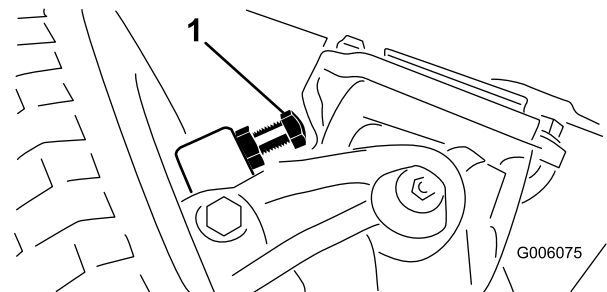

Figure 59

- Steering stop (right side shown)
- Loosen the screw on the tie rod clamp.
- Rotate the ball joint in or out to adjust the length of the tie rod.

4. Install the ball joint to the mounting bracket and check the wheel toe-in.
5. After attaining desired adjustment, tighten the screw on the tie rod clamp and secure the ball joint to the mounting bracket.

Cooling System Maintenance

Cleaning the Radiator and the Screen

Service Interval: Every 200 hours

Every 1,500 hours

Every 1,500 hours

To prevent the engine from overheating, the screen and radiator must be kept clean. Normally, check the screen and radiator daily and, if necessary, clean any debris off these parts. However, it will be necessary to check and clean the screen and radiator frequently in extremely dusty and dirty conditions.

Note: If engine shuts off due to overheating, first check the radiator and screen for excessive buildup of debris.

Clean the radiator as follows:

1. Remove the screen.
2. Working from the fan side of the radiator, blow with low pressure (25 psi) compressed air (**do not use water**). Repeat the step from the front of the radiator and again from the fan side.
3. After the radiator is thoroughly cleaned, clean out debris that may have collected in the channel at the radiator base.
4. Clean and install the screen.

Brake Maintenance

Adjusting the Parking Brake Interlock Switch

1. Turn the engine off and remove the ignition key. Do not engage the parking brake.
2. Remove the knob from parking brake rod and screws from the steering tower cover (Figure 60).

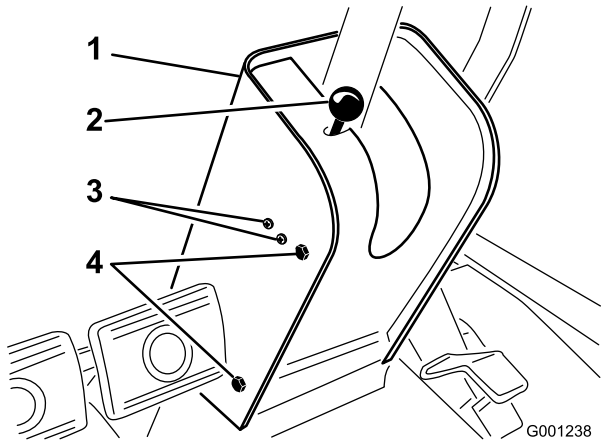

Figure 60

- | | |
|---------------------------|---------------------------|
| 1. Steering tower cover | 3. Switch mounting screws |
| 2. Parking brake knob/rod | 4. Cover mounting screws |

3. Slide the cover up the steering shaft to expose the parking brake switch (Figure 61).
4. Loosen the screws and nuts securing the parking brake switch to the left side of the steering tower (Figure 60).
5. Align the parking brake rod paddle with the switch plunger (Figure 61)

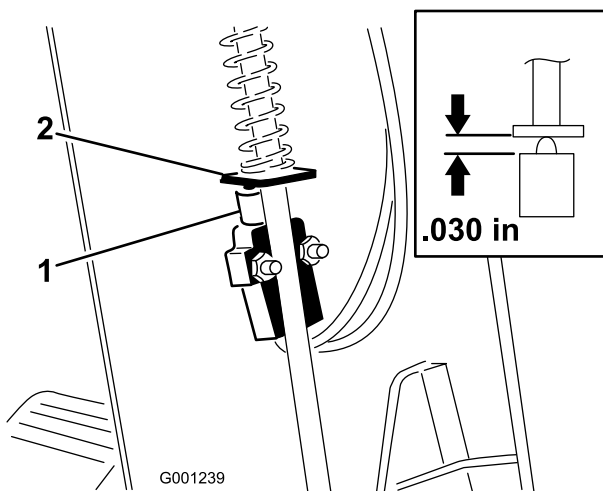

Figure 61

- | | |
|-----------------------------------|-----------------------------|
| 1. Parking brake interlock switch | 2. Parking brake rod paddle |
|-----------------------------------|-----------------------------|

6. Press down on the parking brake rod and push up on the switch until the compressed length of the switch plunger is 0.030 inches (Figure 61, inset). This is the distance between the brake rod paddle and the switch plunger housing.
7. Tighten the switch mounting screws and nuts.
8. With the parking brake disengaged, the switch circuit should have continuity. If there is no continuity, move the switch down slightly until there is continuity.
9. Check the adjustment as follows:
 - A. Engage the parking brake.
 - B. Press the traction pedal while the engine is running and the PTO lever is disengaged.The engine should stop within 2 seconds. If engine stops, the switch is operating correctly; thus, continue operation. If engine does not stop, there is a malfunction in the interlock system that must be corrected.
10. Install the steering tower cover and brake rod knob.

Adjusting the Service Brakes

Service Interval: After the first 10 hours

After the first 50 hours

Every 50 hours

Adjust the service brakes when there is more than one inch (25 mm) of “free travel” of the brake pedals, or when the brakes do not work effectively. Free travel is the distance the brake pedal moves before braking resistance is felt.

The brakes should be checked for adjustment after the first 10 hours of operation and should only need adjusting after considerable use thereafter. These periodic adjustments can be performed where the brake cable connects to the bottom of the brake pedals. When the cable is no longer adjustable, the star nut on the inside of the brake drum must be adjusted to move the brake shoes outward. However, the brake cables must be adjusted again to compensate for this adjustment.

1. Disengage the lock arm from the right brake pedal so that both pedals work independently of each other.
2. To reduce the free travel of the brake pedals, tighten the brakes by loosening the front nut on the threaded end of brake cable (Figure 62). Then tighten the rear nut to move cable backward until the brake pedals have 1/2 to 1 inch (13 mm to 25 mm) of free travel.

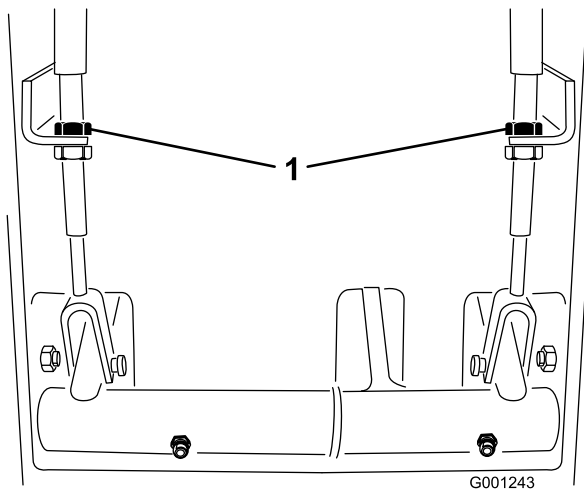

Figure 62

1. Brake cable jam nuts

3. Tighten the front nut after the brakes are adjusted correctly.

Belt Maintenance

Checking the Alternator Belt

Service Interval: Every 200 hours

After the first 10 hours

Check condition and tension of alternator belt (Figure 63) after every 200 operating hours.

1. Proper tension will allow 3/8 inch (10 mm) deflection when a force of 10 lb is applied on the belt, midway between the pulleys.
2. If the deflection is not 3/8 in. (10 mm), loosen the alternator mounting bolts.

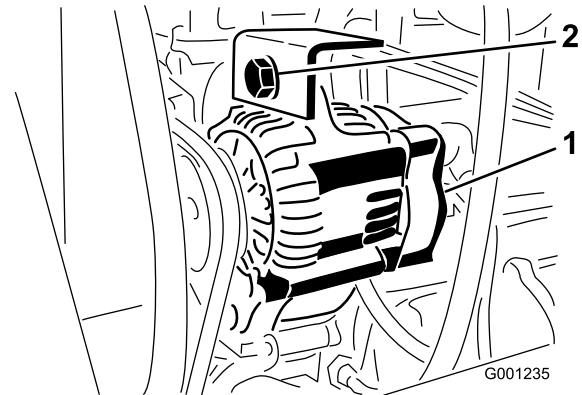

Figure 63

1. Alternator
2. Mounting bolt

3. Increase or decrease the alternator belt tension and tighten the bolts.
4. Check the deflection of the belt again to ensure that the tension is correct.

Servicing the PTO Belt

Checking the PTO Belt Tension

Service Interval: After the first 10 hours

After the first 50 hours

Every 200 hours

1. Turn the engine off, set the parking brake, and remove the ignition key.
2. Raise the engine hood and allow the engine to cool.
3. Loosen the tensioning rod jam nut (Figure 64).

Controls System Maintenance

Adjusting the PTO Clutch

Service Interval: Every 200 hours

1. Turn the engine off, set the parking brake, and remove the ignition key.
2. Raise the engine hood and allow the engine to cool.
3. Adjust the air gap so that a 0.015 inch feeler gauge slides in between the clutch lining and friction plate with light pressure (Figure 65). The gap can be decreased by turning the adjusting nut clockwise (Figure 65). The maximum service gap is 0.030 inch. Adjust all three air gaps.

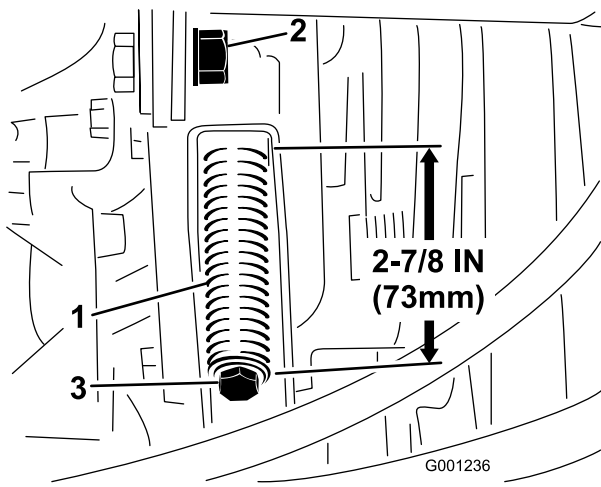

Figure 64

1. Tensioning spring
2. Tensioning rod jam nut
3. Tension adjusting bolt

4. Use a 1/2 inch wrench to tighten or loosen the belt tensioning spring (Figure 64). Adjust spring to a length of 2-7/8 inches (73 mm).
5. Tighten the jam nut.

Replacing the PTO Belt

1. Turn the engine off, set the parking brake, and remove the ignition key.
2. Raise the engine hood and allow the engine to cool.
3. Loosen the tensioning rod jam nut (Figure 64).
4. Using a 1/2 inch wrench, loosen the belt tensioning spring (Figure 64) all the way.
5. Rotate the PTO pulley toward the engine and remove the belt.
6. Install the new PTO belt and tension the pulley spring to 2-7/8 inches (73 mm) (Figure 64).
7. Tighten the jam nut (Figure 64) and close the hood.

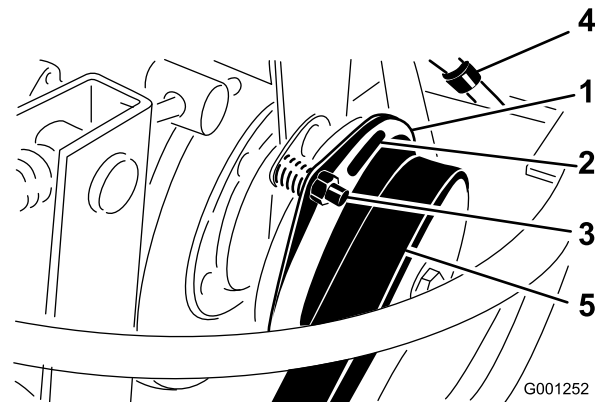

Figure 65

1. Clutch
2. 0.015 inch air gap (3)
3. Adjusting nut (3)

4. After all three gaps have been set, check all three again. Adjusting one gap can alter the other gaps.

Adjusting the Traction Pedal

The traction pedal can be adjusted for operator comfort or to reduce the maximum reverse speed of the machine.

1. Check the traction pedal stop adjustment. The pedal stop (Figure 66) should contact the frame slightly before the pump reaches full stroke.
2. To adjust the pedal stop, loosen the jam nuts, push down on the traction pedal, and tighten the jam nuts when the adjustment is attained.

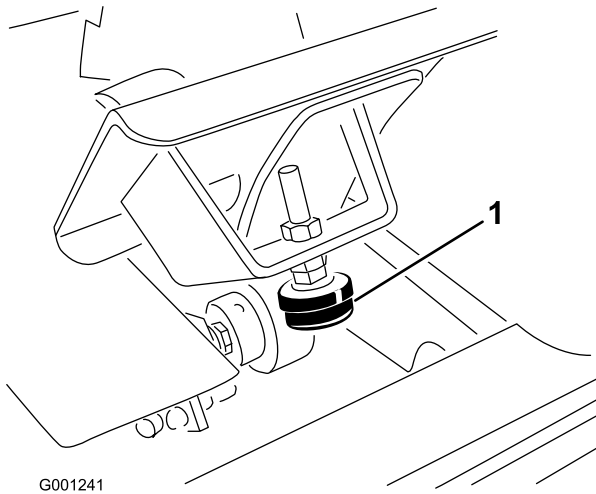

Figure 66

1. Traction pedal stop

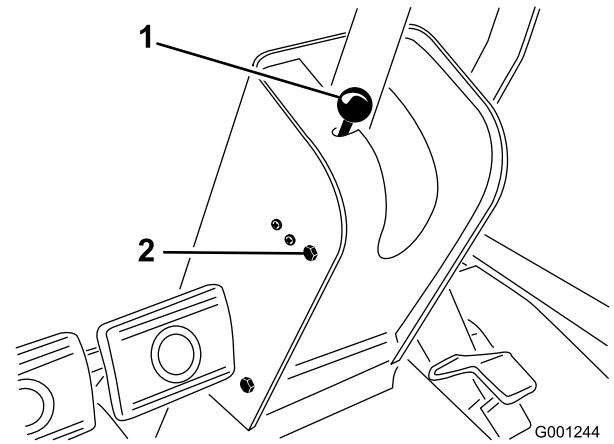

Figure 68

1. Parking brake knob
2. Mounting screw (4)

3. If more adjustment is required, adjust traction rod (Figure 67) as follows:
 - A. Remove the bolt and nut securing traction rod end to the pedal.
 - B. Loosen the jam nut securing rod end to the traction rod.
 - C. Rotate the rod until desired length is attained.
 - D. Tighten the jam nut and secure the rod end to the traction pedal with the bolt and nut removed to lock the angle of the foot pedal.

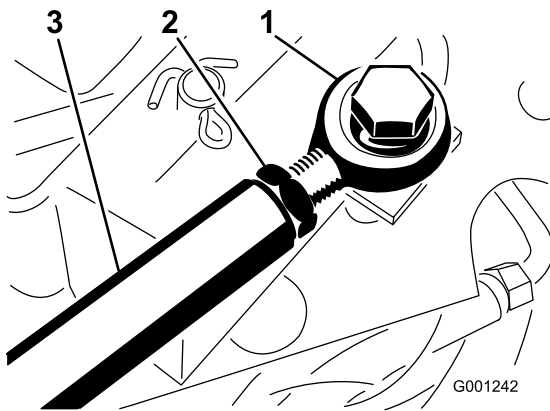

Figure 67

1. Rod end
2. Jam nut
3. Traction rod

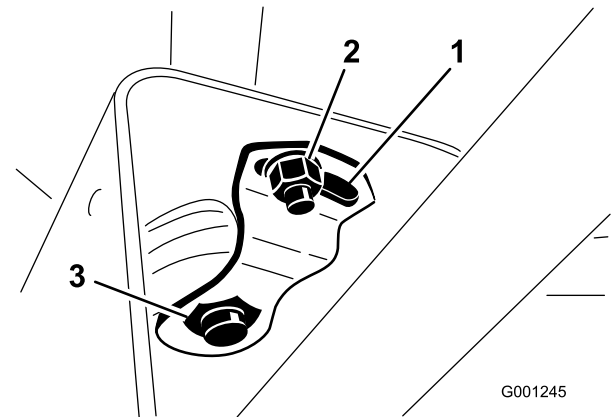

Figure 69

1. Pivot plate
2. Small nut
3. Large nut

3. Loosen the small nut, rotate the pivot bracket until it tightens the large nut below (Figure 69).
4. Tighten small nut.
5. Install the steering column cover and parking brake knob.

Adjusting the Tilt Steering Control

1. Remove the knob from the parking brake and screws from the steering column cover (Figure 68).

Hydraulic System Maintenance

Changing the Hydraulic Oil And Filter

Service Interval: After the first 10 hours—Change the hydraulic oil filter. Do not exceed 10 hours or you will damage the hydraulic system

Every 200 hours—Change the hydraulic oil filter

Every 1,500 hours—Replace the hydraulic oil.

The axle housing acts as the reservoir for the system. The transmission and axle housing are shipped from the factory with approximately 6 quarts (5.6 l) of high quality hydraulic fluid. Check the level of hydraulic oil before the engine is first started and daily thereafter. The recommended replacement oil is as follows:

Toro Premium Transmission/Hydraulic Tractor Fluid
(Available in 5 gallon pails or 55 gallon drums. See parts catalog or Toro distributor for part numbers.)

Alternate fluids: If the Toro fluid is not available, other petroleum-based Universal Tractor Hydraulic Fluids (UTHF) may be used provided its specifications fall within the listed range for all the following material properties and it meets industry standards. We do not recommend the use of synthetic fluid. Consult with your lubricant distributor to identify a satisfactory product
Note: Toro will not assume responsibility for damage caused by improper substitutions, so use only products from reputable manufacturers who will stand behind their recommendation.

Note: Toro will not assume responsibility for damage caused by improper substitutions, so use only products from reputable manufacturers who will stand behind their recommendation.

Material Properties:

Viscosity, ASTM D445	cSt @ 40°C 55 to 62
	cSt @ 100°C 9.1 to 9.8
Viscosity Index ASTM D2270	140 to 152
Pour Point, ASTM D97	-35°F to -46°F

Industry Specifications:

API GL-4, AGCO Powerfluid 821 XL, Ford New Holland FNHA-2-C-201.00, Kubota UDT, John Deere J20C, Vickers 35VQ25, and Volvo WB-101/BM

Note: Fluid to operate the power steering is supplied by the hydraulic system transmission charge pump.

Cold weather start-up may result in stiff operation of the steering until the hydraulic system has warmed up. Using proper weight hydraulic oil in system will minimize this condition.

Note: Many hydraulic fluids are almost colorless, making it difficult to spot leaks. A red dye additive for the hydraulic system oil is available in 2/3 oz. (20 ml) bottles. One bottle is sufficient for 4-6 gal (15-22 l) of hydraulic oil. Order part number 44-2500 from your authorized Toro distributor.

1. Lower the deck to the shop floor, set the parking brake, and turn engine off.
2. Block the two rear wheels.
3. Jack up both sides of the front axle and support it with jack stands.
4. Clean the area around the hydraulic oil filter and remove the filter (Figure 70).

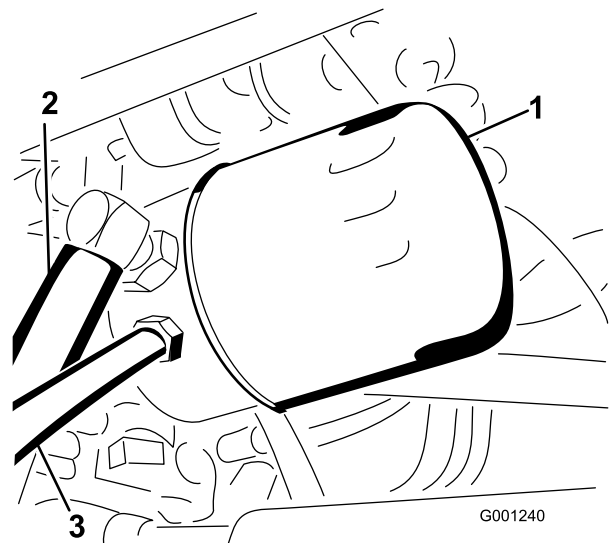

Figure 70

1. Filter
 2. Return line
 3. Suction line
-
5. Remove the tube that connects the axle housing to the transmission and allow the oil to flow into a drain pan.
 6. Install a new hydraulic oil filter and connect the tube between axle housing and transmission.
 7. Fill the axle (reservoir) to the proper level (approximately 6 quarts); refer to Checking the Hydraulic Fluid.
 8. Remove jack stands.
 9. Start the engine, cycle the steering and lift cylinders, and check for oil leaks. Allow the engine to run for about five minutes, then shut it off.
 10. After two minutes, check the level of the hydraulic fluid; refer to Checking the Hydraulic Fluid.

Storage

Machine

1. Thoroughly clean the machine, deck and the engine, paying special attention to these areas:
 - Radiator and radiator screen
 - Underneath the deck
 - Under the deck belt covers
 - Counterbalance springs
 - PTO shaft assembly
 - All grease fittings and pivot points
 - Remove the control panel and clean out inside of the control box
 - Beneath the seat plate and top of the transmission
2. Check the tire pressure. Inflate all machine tires to 20 psi.
3. Remove, sharpen, and balance the mower blades. Install the blades and torque the blade fasteners to 85-110 ft-lb (115-149 N·m).
4. Check all fasteners for looseness and tighten them as necessary.
5. Grease or oil all grease fittings, pivot points, and transmission by-pass valve pins. Wipe off any excess lubricant.
6. Lightly sand and use touch up paint on painted areas that are scratched, chipped or rusted. Repair any dents in the metal body.
7. Service the battery and cables as follows:
 - A. Remove the battery terminals from the battery posts.
 - B. Clean the battery, terminals, and posts with a wire brush and baking soda solution.
 - C. Coat the cable terminals and battery posts with Grafo 112X skin-over grease (Toro Part No. 505-47) or petroleum jelly to prevent corrosion.
 - D. Slowly recharge the battery for 24 hours every 60 days to prevent lead sulfation of the battery.
4. Start the engine and run it at idle speed for two minutes.
5. Drain the fuel from the fuel tank, fuel lines, pump, filter, and separator. Flush the fuel tank with clean diesel fuel and connect all fuel lines.
6. Thoroughly clean and service the air cleaner assembly.
7. Seal the air cleaner inlet and the exhaust outlet with weather proof masking tape.
8. Check the oil filler cap and fuel tank cap to ensure they are securely in place.

Engine

1. Drain the engine oil from the oil pan and replace the drain plug.
2. Remove and discard the oil filter. Install a new filter.
3. Refill the engine with 4 quarts (3.8 l) of recommended motor oil. Refer to Changing the Engine Oil.

Schematics

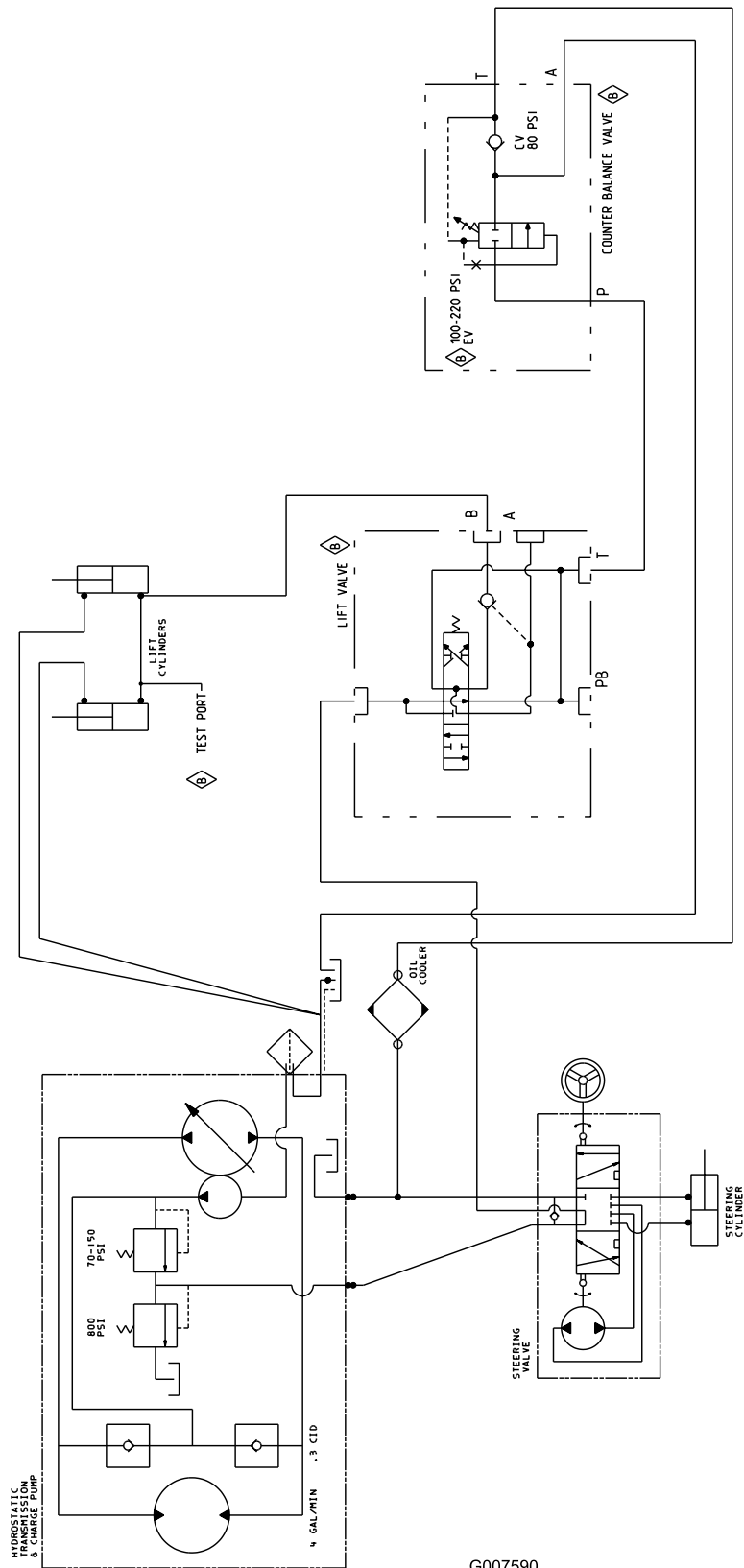

G007590

Hydraulic Schematic (Rev. B)

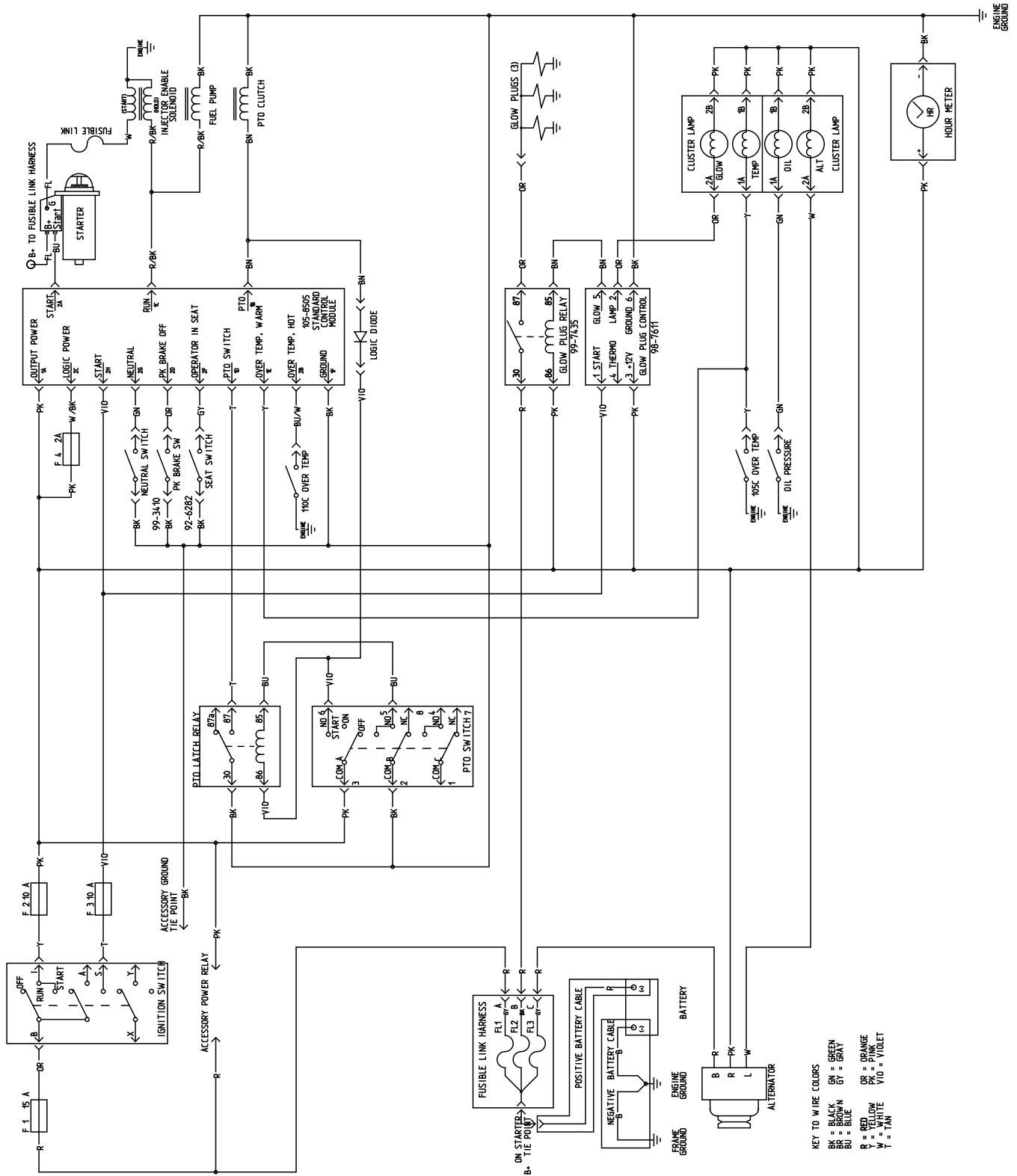

Electrical Schematic (Rev. B)

G001248

Notes:

Notes:



The Toro General Commercial Products Warranty

A Two-Year Limited Warranty

Conditions and Products Covered

The Toro Company and its affiliate, Toro Warranty Company, pursuant to an agreement between them, jointly warrant your Toro Commercial Product ("Product") to be free from defects in materials or workmanship for two years or 1500 operational hours*, whichever occurs first. Where a warrantable condition exists, we will repair the Product at no cost to you including diagnosis, labor, parts, and transportation. This warranty begins on the date the Product is delivered to the original retail purchaser.

* Product equipped with hour meter

Instructions for Obtaining Warranty Service

You are responsible for notifying the Commercial Products Distributor or Authorized Commercial Products Dealer from whom you purchased the Product as soon as you believe a warrantable condition exists.

If you need help locating a Commercial Products Distributor or Authorized Dealer, or if you have questions regarding your warranty rights or responsibilities, you may contact us at:

Toro Commercial Products Service Department
Toro Warranty Company
8111 Lyndale Avenue South
Bloomington, MN 55420-1196
952-888-8801 or 800-982-2740
E-mail: commercial.service@toro.com

Owner Responsibilities

As the Product owner, you are responsible for required maintenance and adjustments stated in your operator's manual. Failure to perform required maintenance and adjustments can be grounds for disallowing a warranty claim.

Items and Conditions Not Covered

Not all product failures or malfunctions that occur during the warranty period are defects in materials or workmanship. This express warranty does not cover the following:

- Product failures which result from the use of non-Toro replacement parts, or from installation and use of add-on, modified, or unapproved accessories
- Product failures which result from failure to perform required maintenance and/or adjustments
- Product failures which result from operating the Product in an abusive, negligent or reckless manner
- Parts subject to consumption through use unless found to be defective. Examples of parts which are consumed, or used up, during normal Product operation include, but are not limited to, blades, reels, bedknives, tines, spark plugs, castor wheels, tires, filters, belts, and certain sprayer components such as diaphragms, nozzles, and check valves, etc.

Countries Other than the United States or Canada

Customers who have purchased Toro products exported from the United States or Canada should contact their Toro Distributor (Dealer) to obtain guarantee policies for your country, province, or state. If for any reason you are dissatisfied with your Distributor's service or have difficulty obtaining guarantee information, contact the Toro importer. If all other remedies fail, you may contact us at Toro Warranty Company.

- Failures caused by outside influence. Items considered to be outside influence include, but are not limited to, weather, storage practices, contamination, use of unapproved coolants, lubricants, additives, or chemicals, etc.
- Normal "wear and tear" items. Normal "wear and tear" includes, but is not limited to, damage to seats due to wear or abrasion, worn painted surfaces, scratched decals or windows, etc.

Parts

Parts scheduled for replacement as required maintenance are warranted for the period of time up to the scheduled replacement time for that part.

Parts replaced under this warranty become the property of Toro. Toro will make the final decision whether to repair any existing part or assembly or replace it. Toro may use factory remanufactured parts rather than new parts for some warranty repairs.

General Conditions

Repair by an Authorized Toro Distributor or Dealer is your sole remedy under this warranty.

Neither The Toro Company nor Toro Warranty Company is liable for indirect, incidental or consequential damages in connection with the use of the Toro Products covered by this warranty, including any cost or expense of providing substitute equipment or service during reasonable periods of malfunction or non-use pending completion of repairs under this warranty. Except for the Emissions warranty referenced below, if applicable, there is no other express warranty. All implied warranties of merchantability and fitness for use are limited to the duration of this express warranty.

Some states do not allow exclusions of incidental or consequential damages, or limitations on how long an implied warranty lasts, so the above exclusions and limitations may not apply to you.

This warranty gives you specific legal rights, and you may also have other rights which vary from state to state.

Note regarding engine warranty: The Emissions Control System on your Product may be covered by a separate warranty meeting requirements established by the U.S. Environmental Protection Agency (EPA) and/or the California Air Resources Board (CARB). The hour limitations set forth above do not apply to the Emissions Control System Warranty. Refer to the Engine Emission Control Warranty Statement printed in your operator's manual or contained in the engine manufacturer's documentation for details.