



66in Rake-O-Vac[®] Sweeper

Model No. 07050 - 270000001 and up.

Parts Catalog

Ordering Replacement Parts

To order replacement parts, please supply the part number, the quantity, and the description of each part desired.

Understanding Reference Numbers

Each identified part in an illustration has a reference number. The reference number for a part also appears in the parts list, along with other information about the part.

This catalog uses two special reference number formats, one to indicate parts in a service assembly and another to indicate the quantity of a given part in an illustration.

Service Assembly Reference Numbers

Parts in service assemblies have reference numbers in the form a:b. The a represents the reference number of the entire service assembly and the b represents a sequential number unique to each part within the service assembly.

For example, a wheel assembly might be identified by reference number 6, the tire by 6:1, the valve by 6:2, and the wheel by 6:3. When you order the assembly identified by reference number 6, you receive all parts identified by reference numbers 6:1, 6:2, and 6:3. However, you may also order any part individually. Reference numbers of this type appear in illustrations and in part lists.

Reference Numbers Indicating Quantity

In an illustration, if a reference number indicates more than one part, the reference number has the form nX y. The n represents the quantity of the part, the X is the multiplication symbol, and the y represents the reference number.

For example, in an illustration, the reference number 2X 37 means that two of the parts identified by reference number 37 are indicated.

Contents

Description	Page	Description	Page
Frame Assembly 3	Head, Valve and Breather Assembly Kohler CH23S-76546 17
Jackshaft and Lifting Mechanism 4	Ignition and Electrical Assembly Kohler CH23S-76546 18
Blower and Throat Assembly 6	Blower Housing and Baffle Assembly Kohler CH23S-76546 19
Hopper and Rear Tailgate Assembly 8	Starting System Assembly Kohler CH23S-76546 20
Flex-Tip Reel and Trailing Arm Assembly 9	Fuel System Assembly Kohler CH23S-76546 21
Jack Assembly 11	Engine Control Assembly Kohler CH23S-76546 22
Engine Assembly 12	Air Intake and Filtration Assembly Kohler CH23S-76546 23
Clutch Assembly No. 107-1050 13	Exhaust Assembly Kohler CH23S-76546 24
Clutch Assembly No. 107-1070 14		
Crankshaft and Crankcase Assembly Kohler CH23S-76546 15		
Oil Pan and Lubrication Assembly Kohler CH23S-76546 16		

Part Description Abbreviations

Part descriptions in this catalog may include the following abbreviations.

AR. as required	HYD. hydraulic
ASM. assembly	LH. left hand
BBC. blade brake clutch	NI. nylon insert
CARR. carriage	NPTF. national pipe thread fine
DEG. degrees	PFH. phillips flat head
EXT. external	PPH. phillips pan head
FH. flat head	PPHTF. phillips pan head thread forming
GA. gauge	PRH. phillips round head
HD. heavy-duty	PTH. phillips truss head
HF. hex flange	PTO. power-take-off
HH. hex head	RH. right hand
HHF. hex head flange	ROPS. roll-over protection system
HHFTF. hex head flange thread forming	SFH. slotted fillister head
HJ. hex jam	SHH. slotted hex head
HLH. hex lag head	SHWH. slotted hex washer head
HOC. height-of-cut	SPH. slotted pan head
HSBH. hex socket button head	SQH. square head
HSFH. hex socket flat head	SRH. slotted round head
HSH. hex socket head	STD. standard
HWH. hex washer head	TAP. self tapping
HWHTF. hex washer head thread forming	TTH. torx truss head

Footnotes

- ❶ Not illustrated
- ❷ Not serviced separately
- ❸ Obtain Parts From Kohler

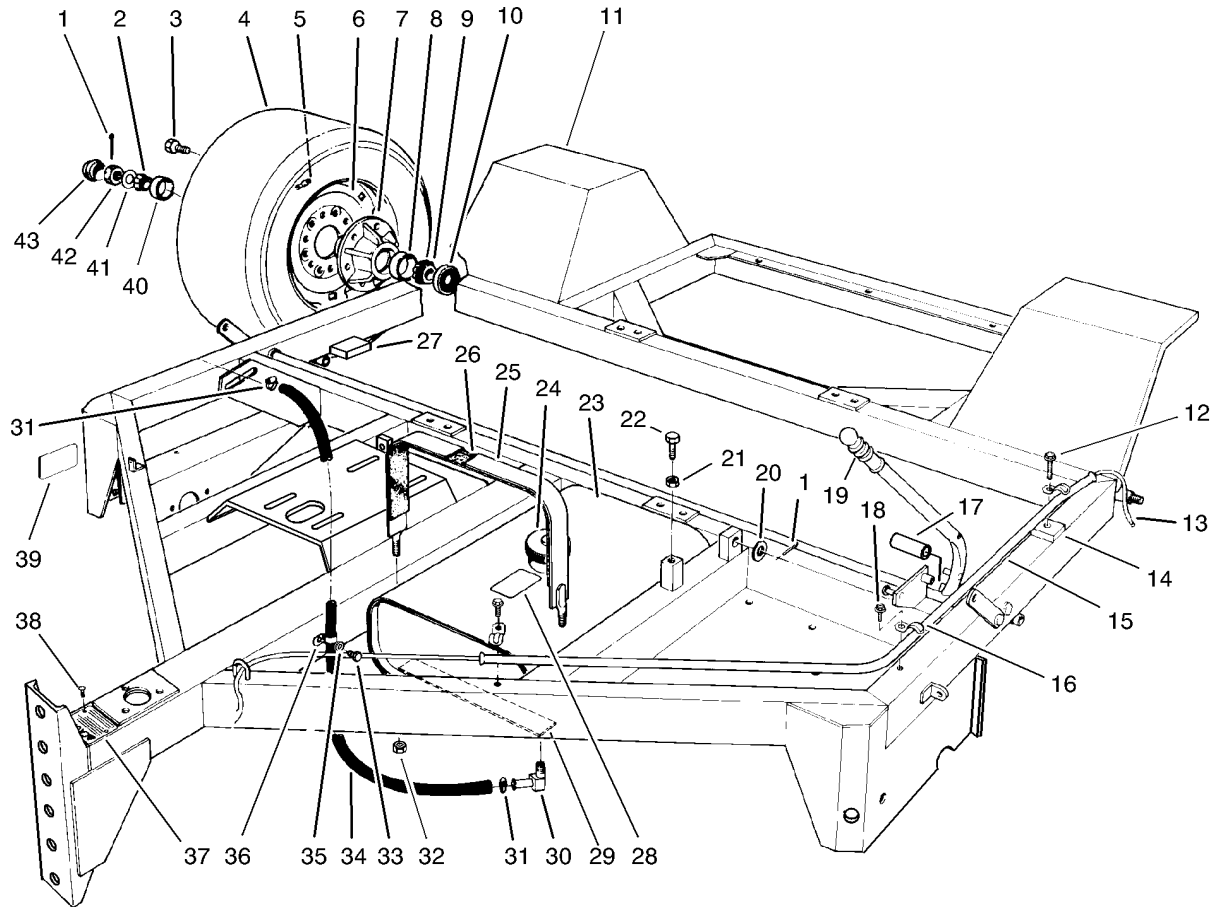

Frame Assembly

Ref	Part No.	Qty.	Description	Ref	Part No.	Qty.	Description
1	3272-17	3	Pin-Cotter	25	13-3960	2	Strap ASM (Includes 26)
2	254-62	2	Bearing-Roller, Cone	26	13-3950	1	Strip-Felt
3	217-103	12	Bolt-Wheel	27	93-7709	1	Pad
4	93-0181	2	Tire	28	53-4420	1	Decal-Gas
5	232-27	2	Stem-Valve	29	13-3970	2	Strip-Felt
6	93-0182	2	Wheel ASM	30	304-75	1	Connector-Hose
7	242-54	2	Hub (Includes 8 And 40)	31	2412-108	2	Clamp-Worm
8	254-66	2	Cup-Bearing, Roller	32	3296-29	4	Nut-Lock, NI
9	254-65	2	Cone-Bearing, Roller	33	32104-109	1	Screw-HWH
10	253-127	2	Seal	34	94-4522	1	Hose-Fuel
11	108-0923-01	1	Frame ASM	35	3256-22	1	Washer-Flat
12	32104-96	1	Screw-HH	36	2412-93	1	Clamp-R
13	20-9580	1	Latch-Rope	37	13-7460	1	Plate-Hitch, Caution
14	13-6910-01	1	Spacer-Guide, Rope	38	3290-55	4	Rivet-Pop
15	13-6890-01	1	Guide-Rope	39	67-5360	1	Decal-Danger
16	2412-40	3	Clamp-Conduit	40	254-61	2	Cup-Bearing
17	3-3107	1	Bumper-Pedal, Clutch	41	3256-29	2	Washer-Flat
18	32104-95	2	Screw-HWH	42	32136-1	2	Nut-Slotted
19	235-15	1	Grip-Handle	43	217-111	2	Cap-Hub
20	3256-28	2	Washer-Flat				
21	3218-3	1	Nut-Jam				
22	323-8	1	Screw-HH				
23	13-3930-01	1	Gas Tank ASM (W/Cap)				
24	222-8	1	Cap-Gas				

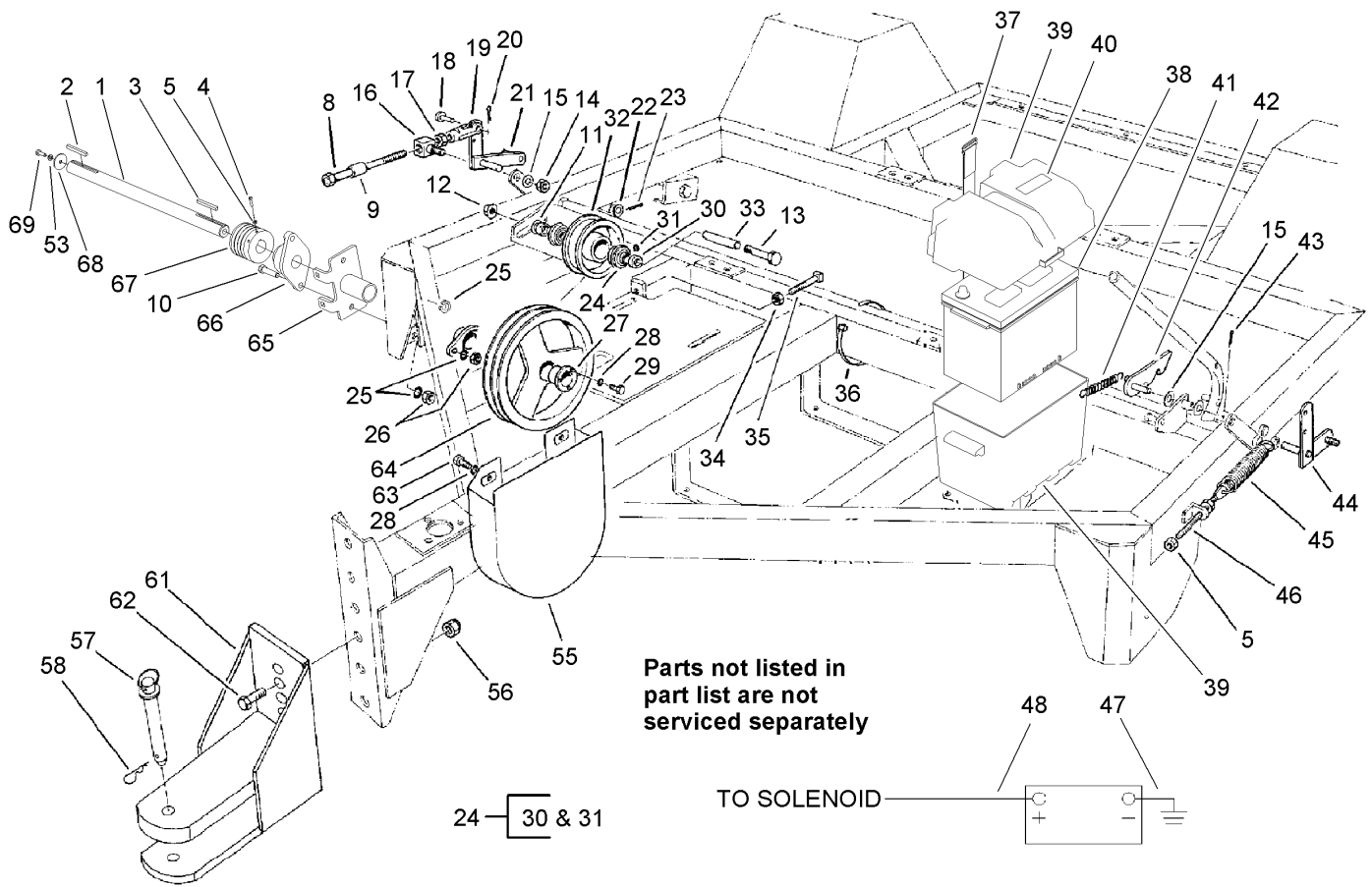

Jackshaft and Lifting Mechanism

Ref	Part No.	Qty.	Description
1	93-4032	1	Shaft-Jack
2	68-3220	1	Key-Stock
3	79-2000	1	Key-Square
4	3243-6	2	Screw-Set, SQH
5	3218-3	6	Nut-Jam
8	13-6260	2	Screw-Adjusting
9	13-5520	2	Spacer-Screw, Adjusting
10	324-7	4	Screw-HH
11	3256-26	1	Washer-Flat
12	32128-49	1	Nut-HHF
13	325-20	1	Screw-HH
14	32153-2	2	Nut-Lock, Side
15	3256-24	7	Washer-Flat
16	13-0100	2	Pivot-Link, Rake Lift
17	3219-3	2	Nut-Hex
18	283-2	2	Pin-Clevis
19	282-22	2	Clevis
20	3272-10	2	Pin-Cotter
21	93-4440	1	Shaft-Pinion
22	3256-28	2	Washer-Flat
23	3272-22	2	Pin-Cotter
24	56-6210	2	Bearing
25	3253-6	5	Washer-Lock
26	3217-8	4	Nut-Hex

Ref	Part No.	Qty.	Description
27	13-2680	1	Bushing (Includes 28-29)
28	3253-4	5	Washer-Lock
29	322-7	3	Screw-HH
30		2	Collar-Locking
31		2	Screw-Set
32	13-0600	1	Pulley-Idler (Includes 24)
33	93-7706	1	Tube-Spacer
34	3218-5	2	Nut-Jam
35	3244-21	2	Screw-SQH
36	250-5	2	Tie-Cable, Long
37	94-1445	1	Strap-Battery
38	55-7290	1	Battery (Dry)
39	93-7595	1	Battery Box ASM
40	61-5950	1	Decal-No Step
41	13-0480	1	Spring
42	13-3990-01	1	Handle-Trip
43	3272-10	1	Pin-Cotter
44	13-5500	1	Bell Crank-Lift, LH
45	13-0050	2	Spring
46	13-5530	2	Rod-Adjust, Spring
47	13-6790	1	Cable-Battery, Negative
48	112-6808	1	Cable-Battery, Positive
53	3253-3	1	Washer-Lock
55	13-4490	1	Guard-Sheave

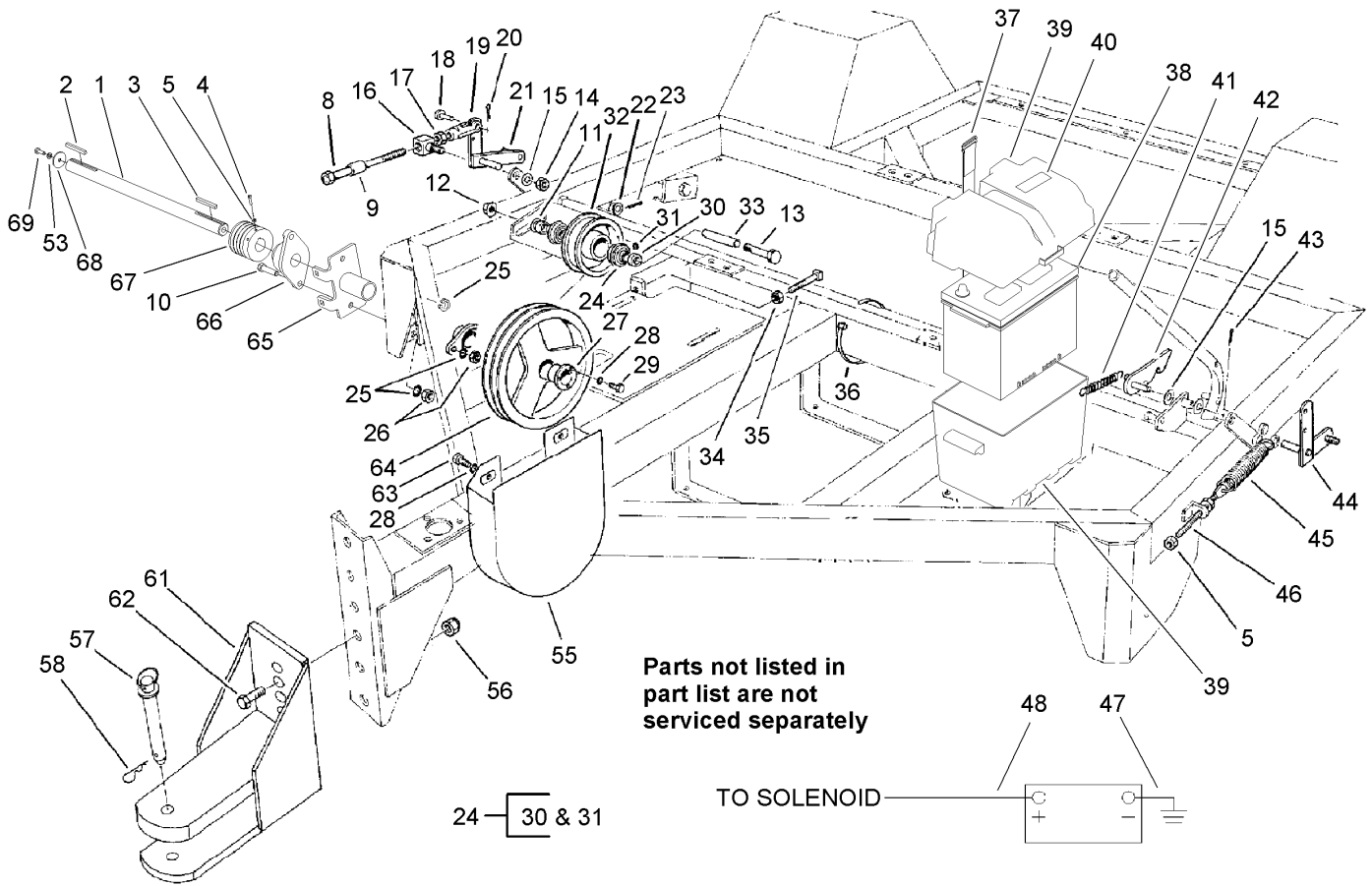

Jackshaft and Lifting Mechanism (continued)

Ref	Part No.	Qty.	Description
56	3296-53	2	Nut-Lock, NI
57	13-6200	1	Pin-Hitch (Includes 58)
58	3290-343	1	Pin-Hair
61	93-4409	1	Tongue
62	327-6	2	Screw-HH
63	322-7	2	Screw-HH
64	13-2670-01	1	Sheave
65	108-0891-01	1	Mount-Guard
66	56-6230	2	Bearing-Roller
67	93-4033-01	1	Pulley-Driver
68	13-3710	1	Washer
69	321-4	1	Screw-HH

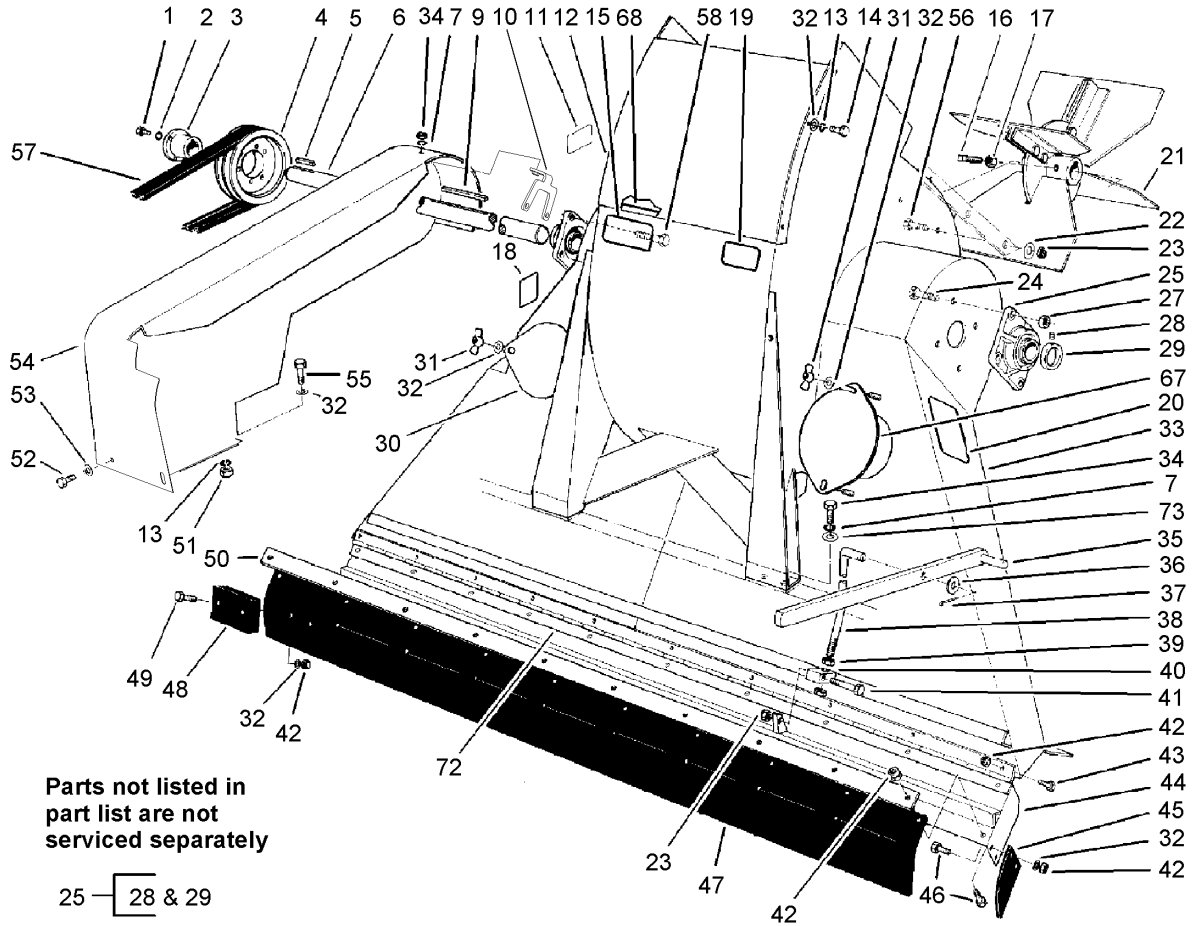

Blower and Throat Assembly

Ref	Part No.	Qty.	Description
1	322-7	3	Screw-HH
2	3253-4	3	Washer-Lock
3	13-2970	1	Bushing (Includes 1-2)
4	13-2800	1	Sheave
5	13-2240	1	Key-Square
6	13-3790	1	Shaft-Fan
7	3253-21	9	Washer-Lock
9	13-2810	1	Key-Square
10	108-0893-01	1	Mount-Guard, Fan
11	67-5360	1	Decal-Danger
12	13-3850-01	1	Boot-Blower
13	3253-3	6	Washer-Lock
14	321-4	4	Screw-HH
15	13-6410	1	Decal-Caution
16	3244-14	4	Screw-Set, SQH
17	3218-5	4	Nut-Jam
18	92-8309	1	Decal-Injury
19	93-7307	1	Decal-Warning
20	93-4041	1	Decal-Instruction
21	13-3420-03	1	Fan ASM
22	3256-24	6	Washer-Flat
23	3296-39	7	Nut-Lock, NI
24	325-6	6	Screw-HH
25	56-6220	2	Bearing

Ref	Part No.	Qty.	Description
27	32153-5	8	Nut-Lock, Side
28		2	Screw-Set
29		2	Collar-Locking
30	13-1420-01	1	Cover-Inspection
31	32103-12	4	Nut-Wing
32	3256-22	32	Washer-Flat
33	13-6280-01	1	Blower (Includes 11-15, 18-20, 30-32, 67-68)
34	323-6	9	Screw-HH
35	13-6390-01	1	Handle-Flap
36	3256-27	1	Washer-Flat
37	3272-12	1	Pin-Cotter
38	13-6360	1	Rod-Lift, Flap
39	3218-6	2	Nut-Jam
40	13-0330	1	Block-Pivot
41	323-9	1	Screw-HH
42	3296-42	52	Nut-Lock, NI
43	321-3	20	Screw-HH
44	95-3112-01	1	Lower Flap Blade ASM
45	13-3130	2	End-Flap
46	321-5	14	Screw-HH
47	13-4700	1	Flap (Includes 23, 42 And 48-49)
48	13-4560-03	18	Weight-Flap
49	321-8	18	Screw-HH

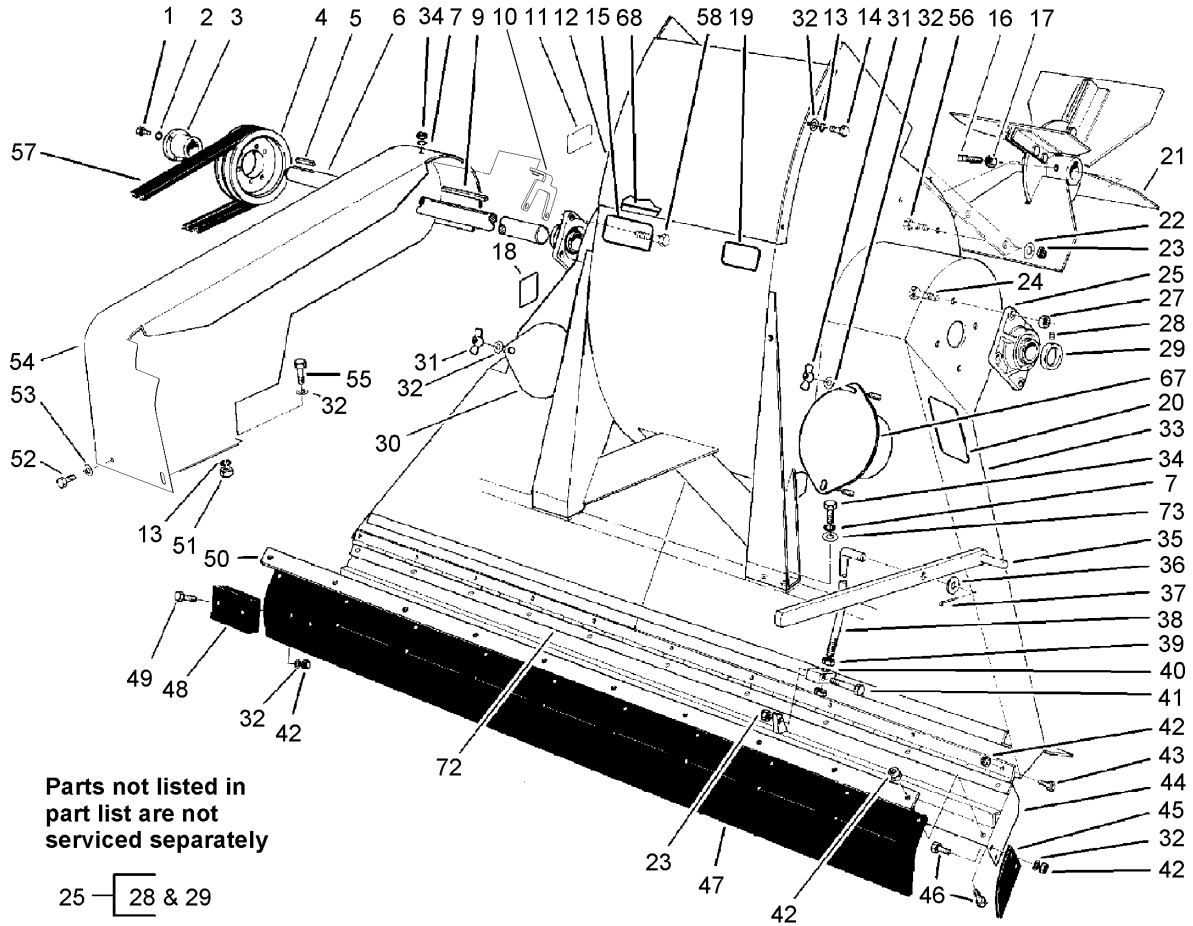

Blower and Throat Assembly (continued)

Ref	Part No.	Qty.	Description
50	13-1390-01	1	Retainer-Flap
51	3217-5	2	Nut-Hex
52	323-5	1	Screw-HH
53	3256-24	1	Washer-Flat
54	108-0921-01	1	Guard-Belt, Fan
55	321-4	2	Screw-HH
56	323-7	6	Screw-HH
57	93-0183	1	Belt V-Impeller
58	325-7	2	Screw-HH
67	93-4020-01	1	Cover-Inspection
68	93-7708	1	Strip-Seal
72	95-3114-01	1	Hinge-Continuous
73	80-6990	8	Washer-Hardened

--	--	--	--

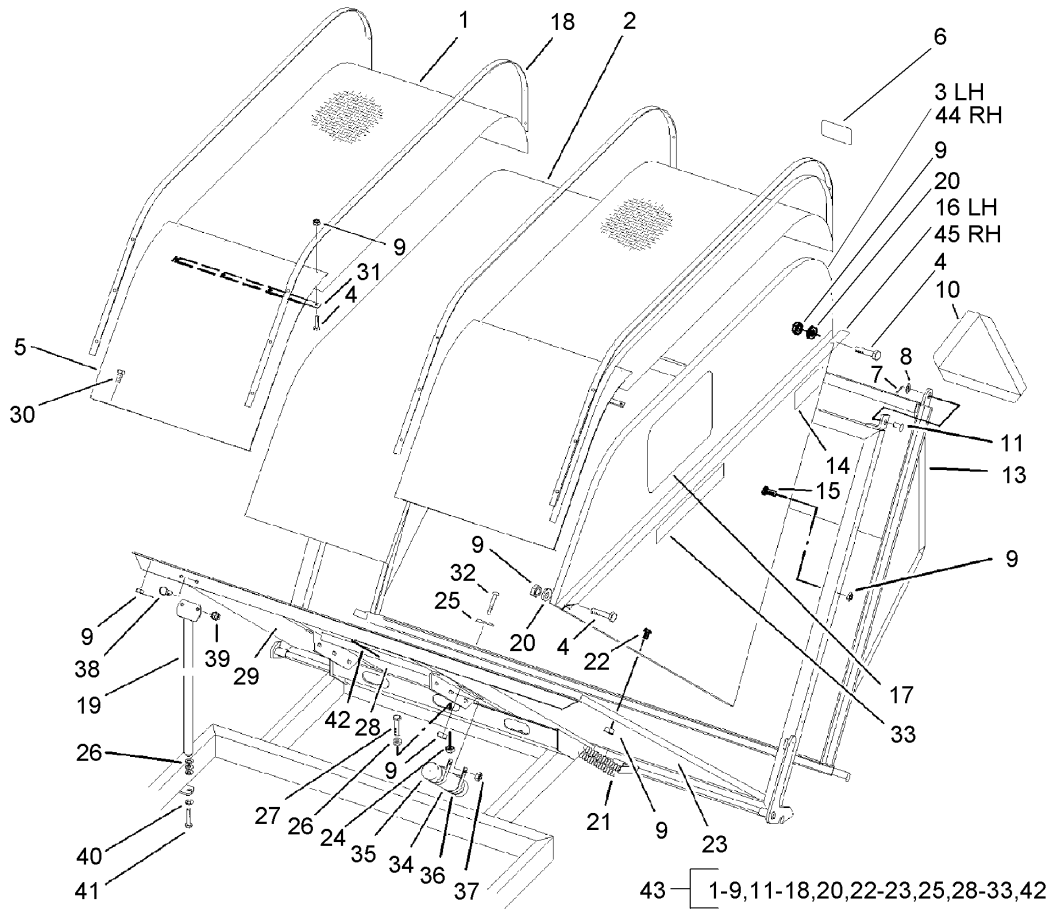

Hopper and Rear Tailgate Assembly

Ref	Part No.	Qty.	Description
1	94-9141-01	2	Screen
2	94-9135-01	1	Top Panel ASM (Hopper)
3	94-9129-01	1	Hopper-Panel, LH
4	3234-33	96	Screw-HHF
5	94-9128-01	2	Panel-Front
6	13-6760	1	Decal-Caution
7	3272-12	3	Pin-Cotter
8	3256-27	3	Washer-Flat
9	32128-32	193	Nut-HHF
10	13-2930	1	Decal
11	283-39	3	Pin-Clevis
13	93-4003-01	1	Tailgate ASM
14	13-7430	1	Decal-Warning
15	3229-7	50	Screw-CARR
16	13-7340-01	1	Stiffener-LH
17	67-7920	2	Decal
18	93-4031-01	4	Strap-Hopper, Top
19	93-4042-01	2	Support-Hopper
20	3256-55	28	Washer-Flat
21	12-8810	2	Spring-Clutch
22	32122-42	36	Screw
23	94-9139-01	1	Panel-Bottom, LH
24	3296-23	3	Nut-Lock, NI
25	13-3710	2	Washer

Ref	Part No.	Qty.	Description
26	3256-26	9	Washer-Flat
27	325-6	3	Screw-HH
28	94-9138-01	1	Panel-Bottom, Center
29	94-9137-01	1	Panel-Bottom, RH
30	3250-32	9	Screw-PPH
31	93-4030-01	2	Strap-Hopper, Front
32	3274-54	2	Screw-HSH
33	93-0184	2	Decal-Hopper
34	65-5871	1	Tube
35	65-5890	2	Cap-End
36	2412-102	2	Clamp-R
37	32153-2	2	Nut-Lock, Side
38	323-6	4	Screw-HH
39	3296-39	4	Nut-Lock, NI
40	3253-7	2	Washer-Lock
41	325-7	2	Screw-HH
42	93-7708	1	Strip-Seal
43	92-2409	1	Hopper ASM
44	94-9133-01	1	Panel-Hopper, RH
45	13-7330-01	1	Stiffener-RH

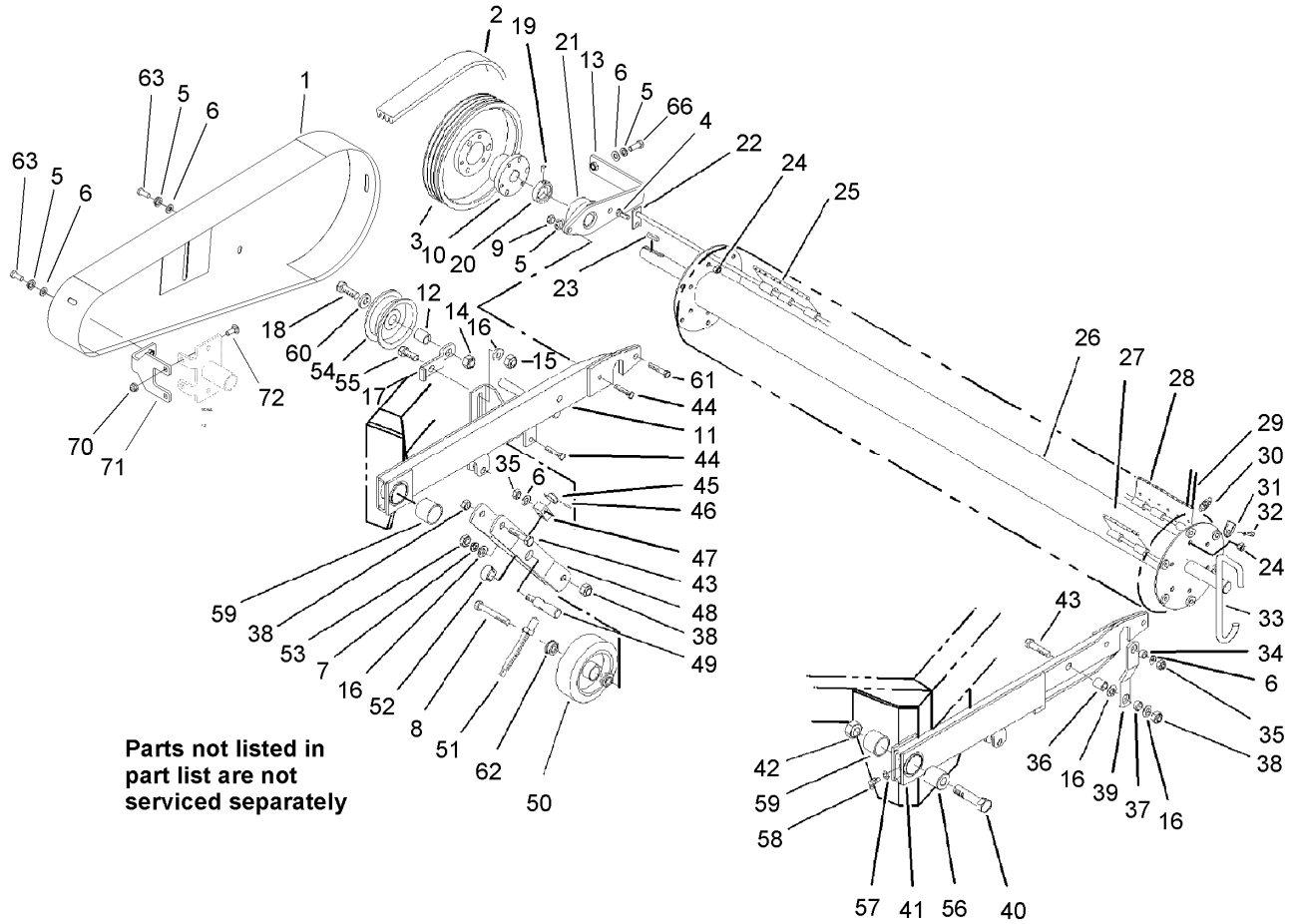

Flex-Tip Reel and Trailing Arm Assembly

Ref	Part No.	Qty.	Description
1	93-4422-01	1	Guard-Belt
2	93-4034	1	V-Belt
3	93-4001-01	1	Pulley-4 Groove
4	323-4	5	Screw-HH
5	3253-21	7	Washer-Lock
6	3256-24	7	Washer-Flat
7	3253-7	2	Washer-Lock
8	325-14	2	Screw-HH
9	3217-7	4	Nut-Hex
10	13-2680	1	Bushing
11	93-4445-01	1	Arm-Trailing, RH
12	93-4428	1	Spacer-Pulley
13	108-0893-01	1	Mount-Guard, Fan
14	3296-53	1	Nut-Lock, NI
15	3296-23	1	Nut-Lock, NI
16	3256-26	7	Washer-Flat
17	93-4433-01	1	Bracket-Pulley
18	327-6	1	Screw-HH
19		2	Screw-Set
20		2	Collar-Locking
21	56-6230	2	Bearing (Includes 19-20)
22	13-4960	6	Shaft-Plate, Finger
23	13-2840	1	Key-Square
24	32152-2	12	Nut-Lock, Cone

Ref	Part No.	Qty.	Description
25	93-0189	3	End Plate ASM
26	93-0197-01	1	Reel ASM
27	93-0185	60	Center Plate ASM
28	93-0187	3	End Plate ASM
29	13-2470	276	Finger-Plastic
30	13-3090	66	Spring-Finger
31	13-2480	276	Clamp-Finger
32	32140-94	276	Screw-HH, Sems
33	93-7711	2	Hook-Transport
34	13-0560	2	Spacer
35	32153-2	4	Nut-Lock, Side
36	13-0360	2	Spacer
37	13-3070	2	Spacer
38	32153-5	6	Nut-Lock, Side
39	13-5540	2	Lift Link
40	328-10	1	Screw-HH
41	63-5300-01	1	Arm-Trailing, LH (Includes 59)
42	32153-6	1	Nut-Lock
43	325-9	4	Screw-HH
44	323-9	4	Screw-HH
45	13-0320	2	Collar-Lock
46	32121-45	2	Pin-Spring
47	13-0330	2	Block-Pivot
48	13-5550-01	2	Arm-Wheel, Gauge

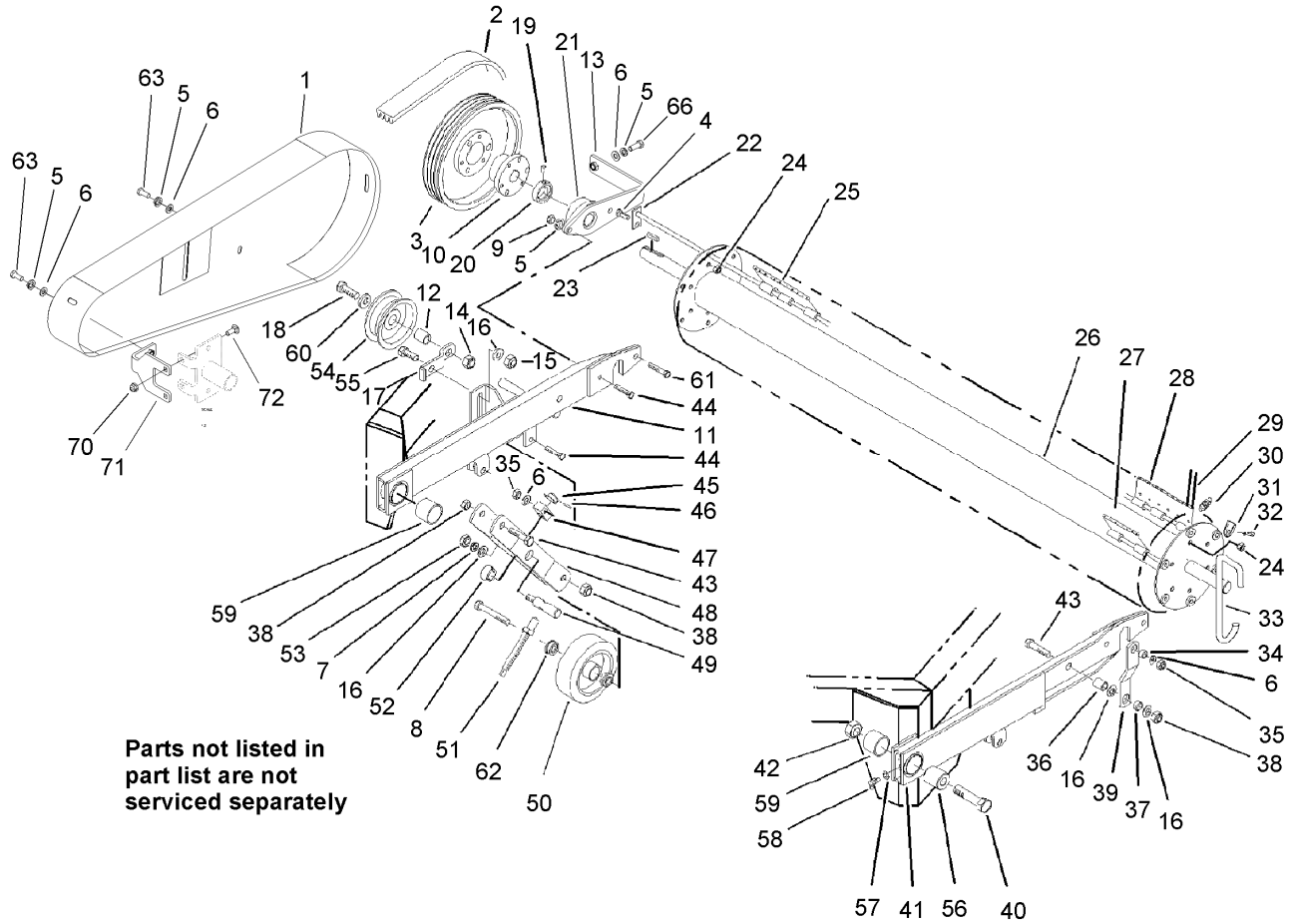

Flex-Tip Reel and Trailing Arm Assembly (continued)

Ref	Part No.	Qty.	Description
49	13-5570	2	Pivot
50	13-2870	2	Wheel-Gauge (Includes 62)
51	13-5590	2	Rod-Adjusting
52	13-5670	2	Spacer-Locking
53	3217-9	2	Nut-HH
54	93-4415	1	Pulley-Idler
55	325-5	1	Screw-HH
56	63-5250	1	Spacer-Arm
57	3254-8	2	Washer-Lock
58	302-5	2	Fitting-Grease
59	256-298	2	Bushing
60	93-4429	1	Washer-Pulley
61	323-10	2	Screw-HH
62	93-7715	4	Bearing-Ball
63	323-5	4	Screw-HH
●64	3253-4	3	Washer-Lock
●65	322-7	3	Screw-HH
66	323-6	1	Screw-HH
70	104-8301	2	Nut-Flange, NI
71	108-0892-01	1	Arm ASM
72	3231-2	2	Screw-CARR

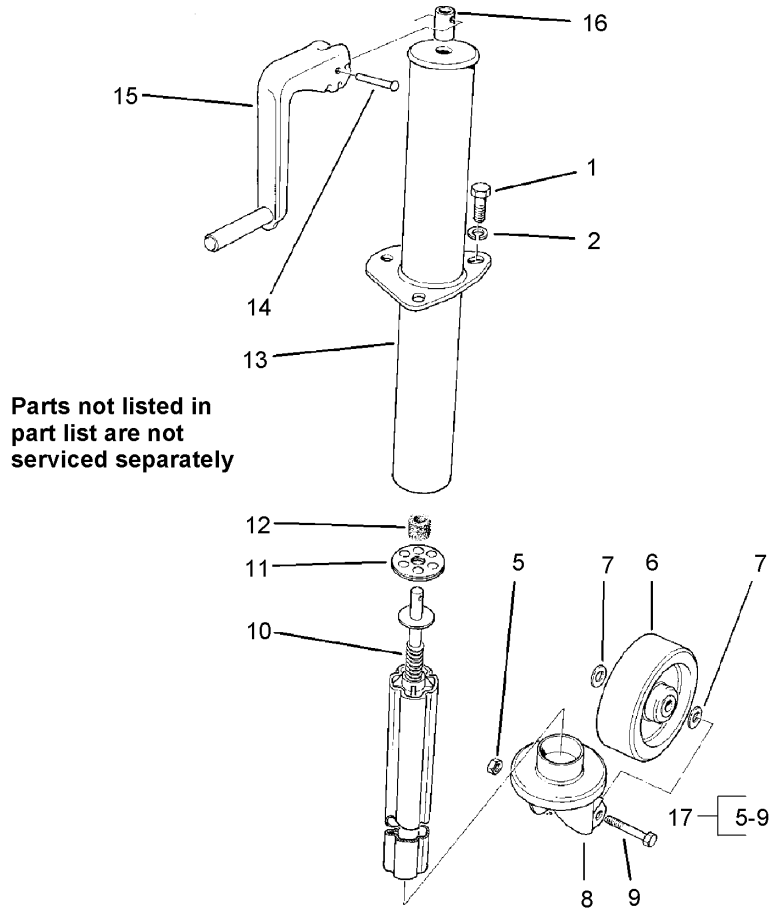

Jack Assembly

Ref	Part No.	Qty.	Description
1	323-4	3	Screw-HH
2	3253-21	3	Washer-Lock
5	3296-23	1	Nut-Lock, NI
6	13-6460	1	Wheel-Caster
7	3256-26	2	Washer-Flat
8	13-6450-01	1	Caster
9	325-13	1	Screw-HH
10		1	Ram
11	13-3510	1	Bearing-Thrust
12	13-3610	1	Sleeve-Felt
13	13-5680	1	Jack ASM (Includes 10-16)
14	13-6730	1	Rivet
15	13-6740	1	Handle
16	13-3490	1	Sleeve-Handle
17	13-6460	1	Wheel ASM (Includes 5-9)

--	--	--	--

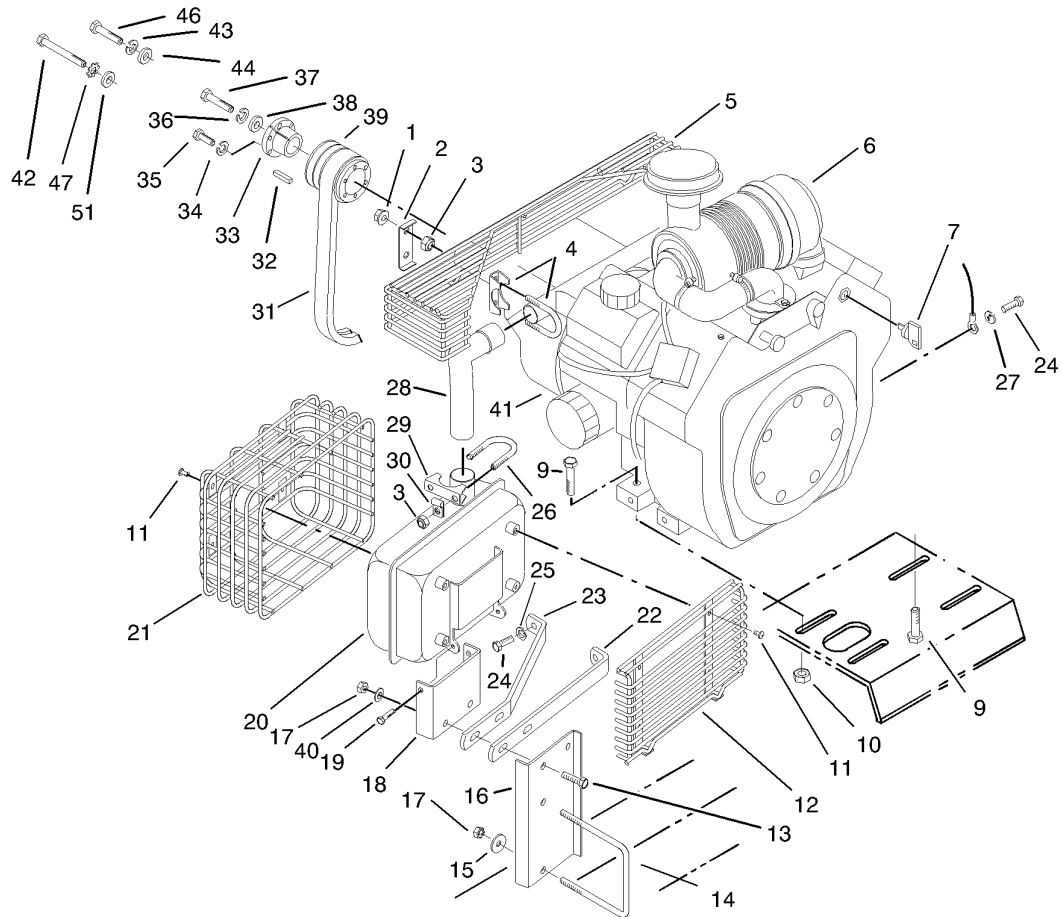

Engine Assembly

Ref	Part No.	Qty.	Description
1	32128-20	4	Nut-HF
2	93-7703-03	2	Plate-Clamp, Guard
3	32153-3	5	Nut-Hex, Side Deform
4	94-1756	2	Clamp-Muffler
5	93-4418-03	1	Guard-Manifold
⑥		1	Engine-Kohler, Ch23S-76546
7	63-8360	2	Key-Ignition
9	323-9	4	Screw-HH
10	32128-29	4	Locknut-Flange
11	47-2830	8	Screw-Metric
12	93-4419-03	1	Guard-Muffler, Rear
13	322-6	2	Screw-HH
14	93-4417	1	U-Bolt
15	3256-82	2	Washer-Flat
16	93-4416-03	1	Bracket-Support, Muffler
17	3296-47	4	Nut-Lock, NI
18	93-0198-03	1	Bracket-Support, Muffler
19	46-6810	2	Screw And Washer ASM
⑳		1	Muffler
㉑		1	Guard-Muffler
22	93-4000-03	1	Strap-Support, Muffler
23	93-0199-03	1	Strap-Support, Muffler
24	33114-016	3	Screw-HH
25	3253-4	2	Washer-Lock

Ref	Part No.	Qty.	Description
26	2112-11	1	Clamp-Muffler (Includes 29)
27	3254-2	1	Washer-Lock, Internal
㉘		1	Pipe-Exhaust
㉙		1	Clamp-Muffler
30	2412-103	1	Clamp
31	13-2650	1	Belt-V
32	3-9155	1	Key-Square
33	13-3330	1	Bushing (Includes 37-38)
34	3253-3	3	Washer-Lock
35	321-6	3	Screw-HH
36	3253-21	1	Washer-Lock
37	323-10	1	Screw-HH
38	4-1920	1	Washer
39	13-3320	1	Sheave
40	3256-23	2	Washer-Flat
41	106-9652	1	Clutch ASM
42	324-31	2	Screw-HH
43	3253-6	2	Washer-Lock
44	3256-25	4	Washer-Flat
46	324-12	2	Screw-HH
47	3255-16	2	Washer-Lock/EXT
51	37-4700	2	Spacer-Wheel

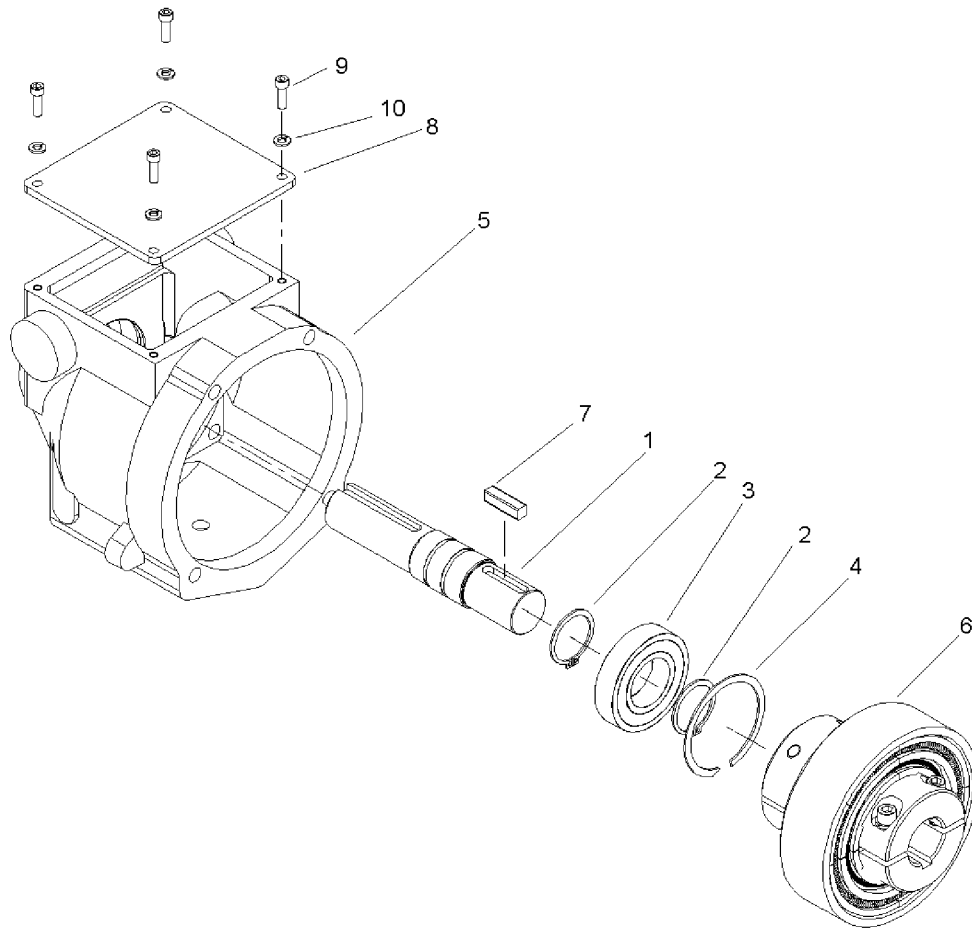

Clutch Assembly No. 107-1050

Ref	Part No.	Qty.	Description
1	107-1052	1	Shaft
2	107-1053	2	Ring-Retaining
3	107-1054	1	Bearing
4	107-1055	1	Ring-Retaining
5		1	Housing
6	107-1070	1	Centrifugal Clutch ASM
7	107-1057	1	Key
8	107-1058	1	Cover
9	3274-8	4	Screw-HSH
10	3253-3	4	Washer-Lock

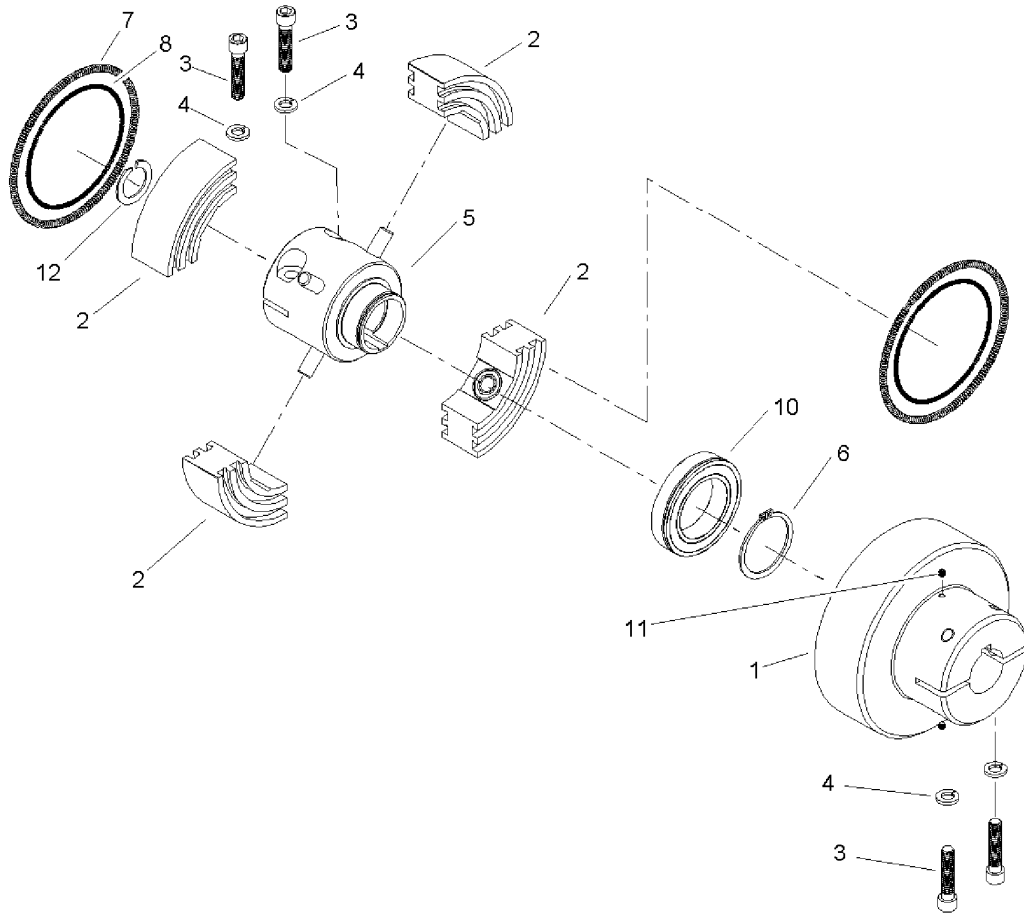

Clutch Assembly No. 107-1070

Ref	Part No.	Qty.	Description
1		1	Housing-Clutch
2	107-1072	4	Shoe ASM
3	3274-3	4	Screw-HSH
4	3253-21	4	Washer-Lock
5	107-1081	1	Hub ASM
6	107-1074	1	Ring-Retaining
7	107-1075	2	Spring
8	107-1076	2	Spring
10	107-1078	1	Bearing
11	107-1079	2	Point-Cone
12	107-1080	1	Ring-Retaining

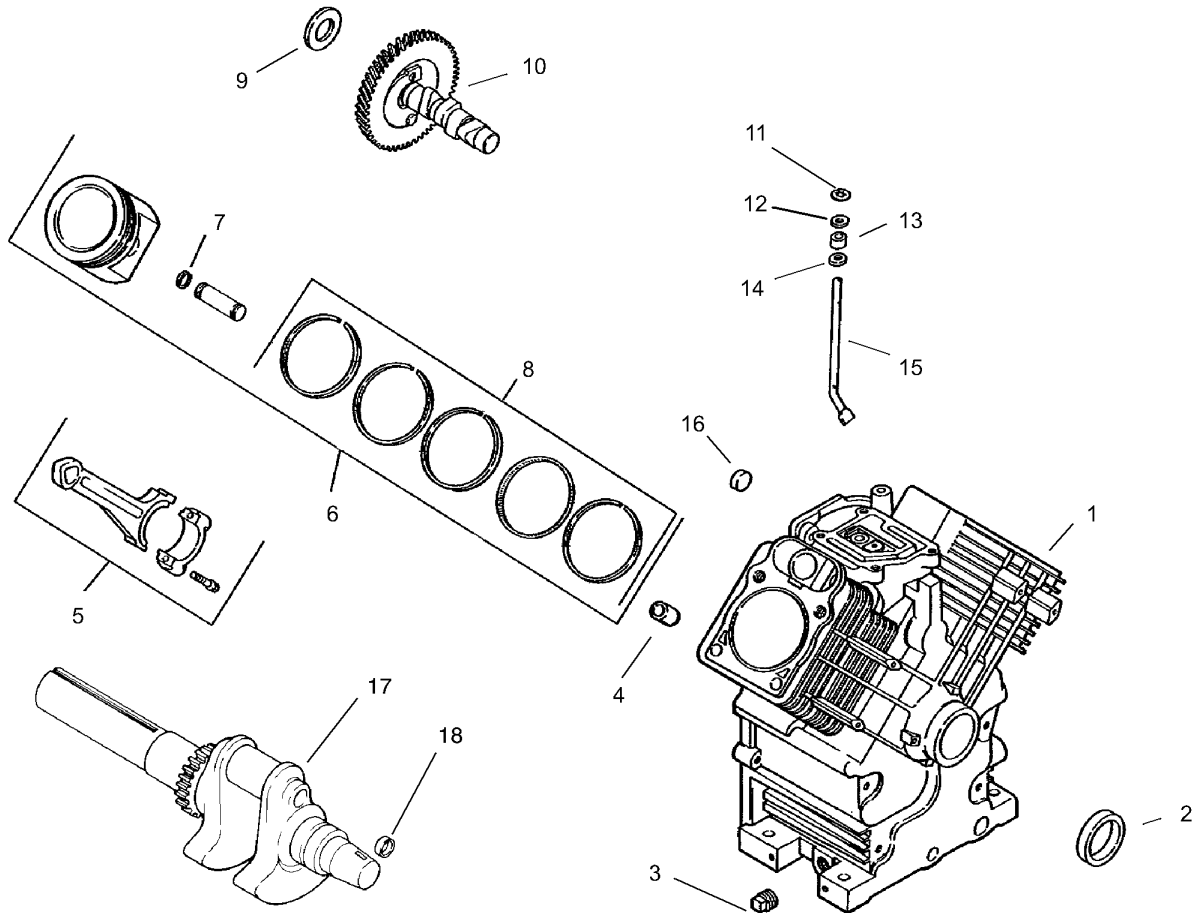

Crankshaft and Crankcase Assembly Kohler CH23S-76546

Ref	Part No.	Qty.	Description
❶	N/A	1	Short Block
❷	24 032 01	1	Seal-Oil
❸	25 139 57	2	Plug-Pipe, SQH
❹	24 380 13	6	Pin-Locating
❺	24 067 13	2	Rod-Connecting (Standard)
❻	24 067 14	2	Rod-Connecting (.25)
❼	24 874 09	2	Piston W/Ring Set (Standard) (Includes 7-8)
❽	24 874 10	2	Piston W/Ring Set (.25)
❾	24 874 11	2	Piston W/Ring Set (.50)
❿	24 874 15	2	Piston W/Ring Set (.080)
⓫	24 018 01	4	Retainer-Piston Pin
⓬	24 108 08	2	Ring Set (Standard)
⓭	24 108 09	2	Ring Set (.25)
⓮	24 108 10	2	Ring Set (.50)
⓯	12 422 09	0	Shim-Camshaft
⓰	12 422 13	0	Shim-Camshaft
⓱	12 422 07	0	Shim-Camshaft
⓲	12 422 08	0	Shim-Camshaft
⓳	12 422 10	0	Shim-Camshaft
⓴	12 422 11	0	Shim-Camshaft
⓵	12 422 12	0	Shim-Camshaft
⓶	24 012 10	1	Camshaft
⓷	24 018 09	1	Ring-Retaining

Ref	Part No.	Qty.	Description
❸	M-931010	1	Washer-Plain
❹	28 032 09	1	Seal-Shaft, Governor
❺	24 468 15	1	Washer
❻	24 144 33	1	Shaft-Cross, Governor
❼	52 139 09	1	Plug
❽	24 014 78	1	Crankshaft (Includes 18)
❾	52 139 09	1	Plug

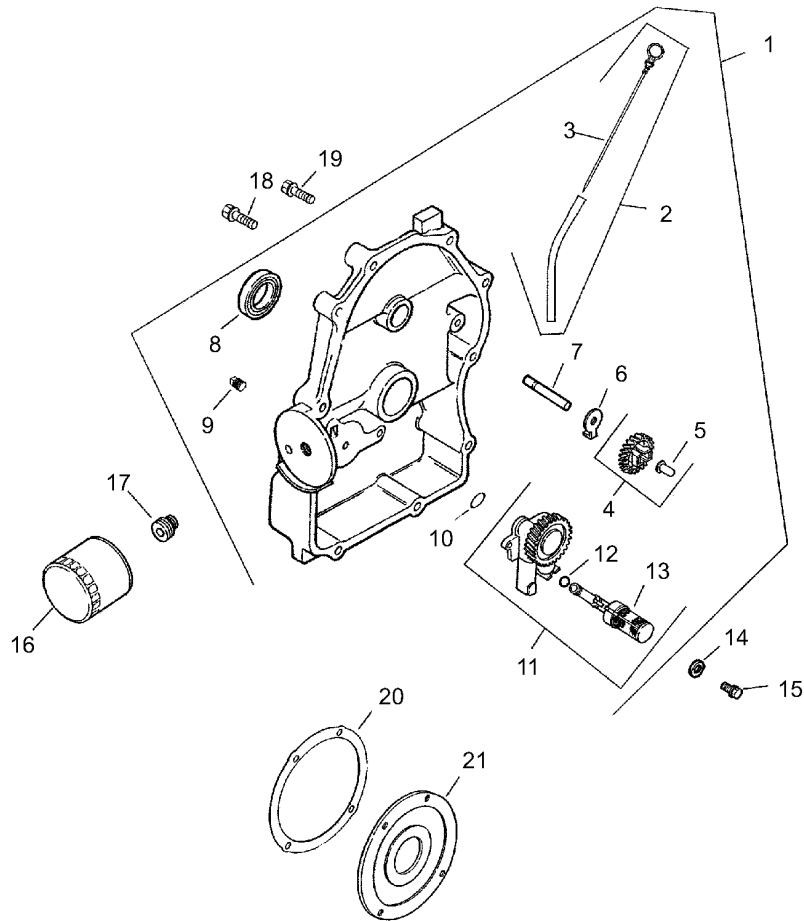

Oil Pan and Lubrication Assembly Kohler CH23S-76546

Ref	Part No.	Qty.	Description
❶1	24 009 90	1	Closure Plate ASM (Includes 2-13)
❷2	24 755 121	1	Dipstick Tube ASM (Includes 3)
❸3	24 038 10	1	Dipstick
❹4	24 043 12	1	Governor Gear Kit (Includes 5)
❺5	12 380 01	1	Pin-Governor
❻6	52 448 02	1	Tab-Locking
❼7	12 144 02	1	Shaft-Gear, Governor
❽8	52 032 08	1	Seal-Oil
❾9	25 139 60	2	Plug-Pipe, SQH
❿10	24 153 08	1	O Ring
⓫11	24 393 10	1	Oil Pump ASM (Includes 12-13)
⓬12	24 153 01	1	O-Ring
⓭13	24 381 04	1	Pick Up-Oil
⓮14	M-631005	2	Washer
⓯15	M-645025	2	Screw
⓰16	12 050 01	1	Filter-Oil
⓱17	24 136 01	1	Nipple-Filter, Oil
⓲18	24 086 16	9	Screw
⓳19	24 086 17	1	Screw
⓴20	24 041 25	1	Gasket-Clutch
⓵21	24 146 10	1	Plate-Adapter

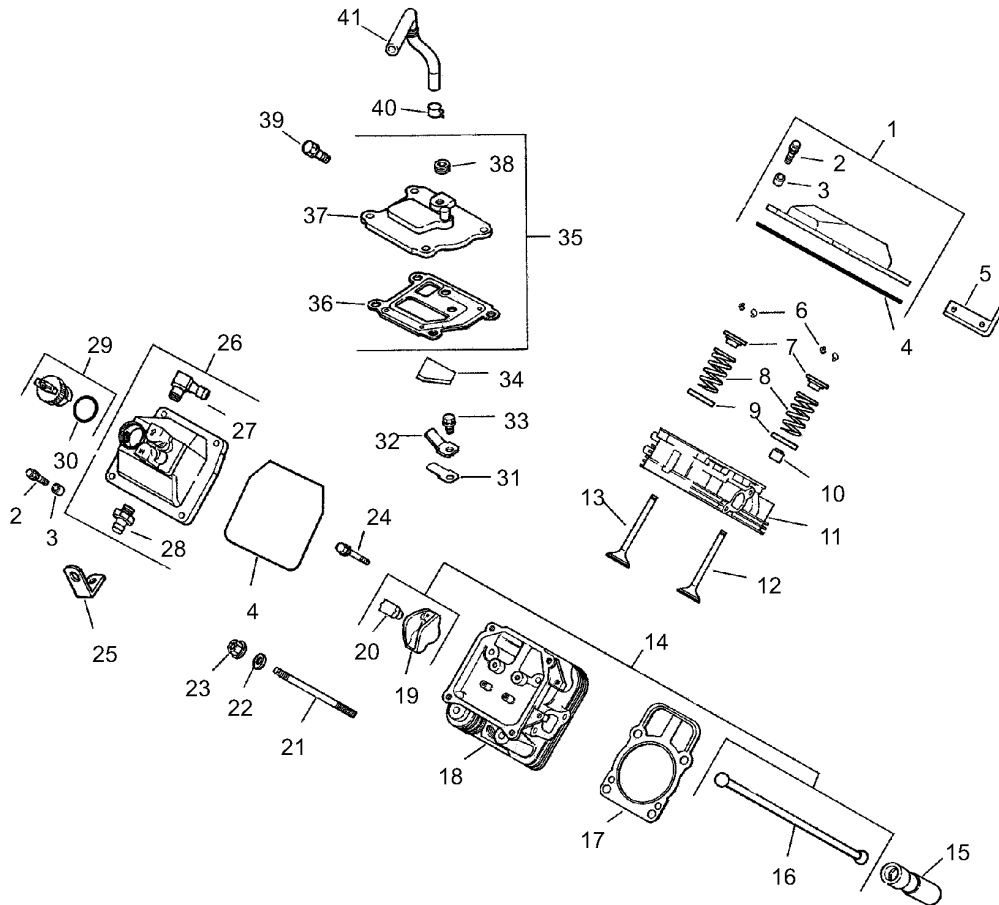

Head, Valve and Breather Assembly Kohler CH23S-76546

Ref	Part No.	Qty.	Description	Ref	Part No.	Qty.	Description
❶	24 755 74	1	Valve Cover Kit (Includes 2-4)	❷	24 468 16	8	Washer-Flat
❷	M-651030	4	Screw-HHF	❸	24 100 10	8	Nut-HF
❸	24 112 08	4	Spacer	❹	M-640034	4	Screw-HF (M6X1.0X34)
❹	24 153 16	1	O-Ring	❺	12 445 05	1	Strap-Lifting
❺	24 455 01	1	Strap-Lifting	❻	24 393 12	1	Cover-Valve (Includes 27-28)
❻	12 755 03	4	Retainer Kit	❼	25 155 02	1	Connector
❼	12 173 01	4	Cap-Spring, Valve	❽	25 326 03	2	Connector-Straight
❽	24 089 02	4	Spring-Valve	❾	24 227 02	1	Oil Fill Cap ASM (Includes 30)
❾	235011	4	Retainer-Spring	❿	24 153 09	1	O-Ring
❿	24 032 05	2	Seal-Stem, Valve	⓫	24 402 03	1	Reed
⓫	24 318 68	1	Cylinder Head ASM No. 1	⓬	12 018 01	1	Retainer-Reed
⓬	24 017 01	2	Valve-Intake	⓭	M-545010	1	Screw (M5X0.8X10)
⓭	24 017 02	2	Valve-Intake (.25)	⓮	24 050 01	1	Filter-Breather
⓮	24 016 01	2	Valve-Exhaust	⓯	24 033 01	1	Breather And Plu Kit (Includes 36-38)
⓯	24 016 02	2	Valve-Exhaust (.25)	⓰	24 041 23	1	Gasket-Breather
⓰	24 755 66	1	Valve Train Kit (Includes 16, 19 And 20)	⓱	24 096 58	1	Cover-Breather
⓱	25 351 01	4	Lifter-Valve	⓲	25 139 60	1	Plug-Pipe, SQH
⓲	24 411 05	4	Rod-Push	⓳	M-645020	4	Screw-HF (M6X1.0X20)
⓳	24 041 40	2	Gasket-Head, Cylinder	⓴	25 237 08	2	Clamp-Breather
⓴	24 318 71	1	Cylinder Head ASM No. 2	⓵	24 326 31	1	Hose-Breather
⓵	25 186 01	4	Arm-Rocker				
⓶	24 599 01	4	Pivot-Arm, Rocker				
⓷	24 072 09	8	Stud-Head, Cylinder				

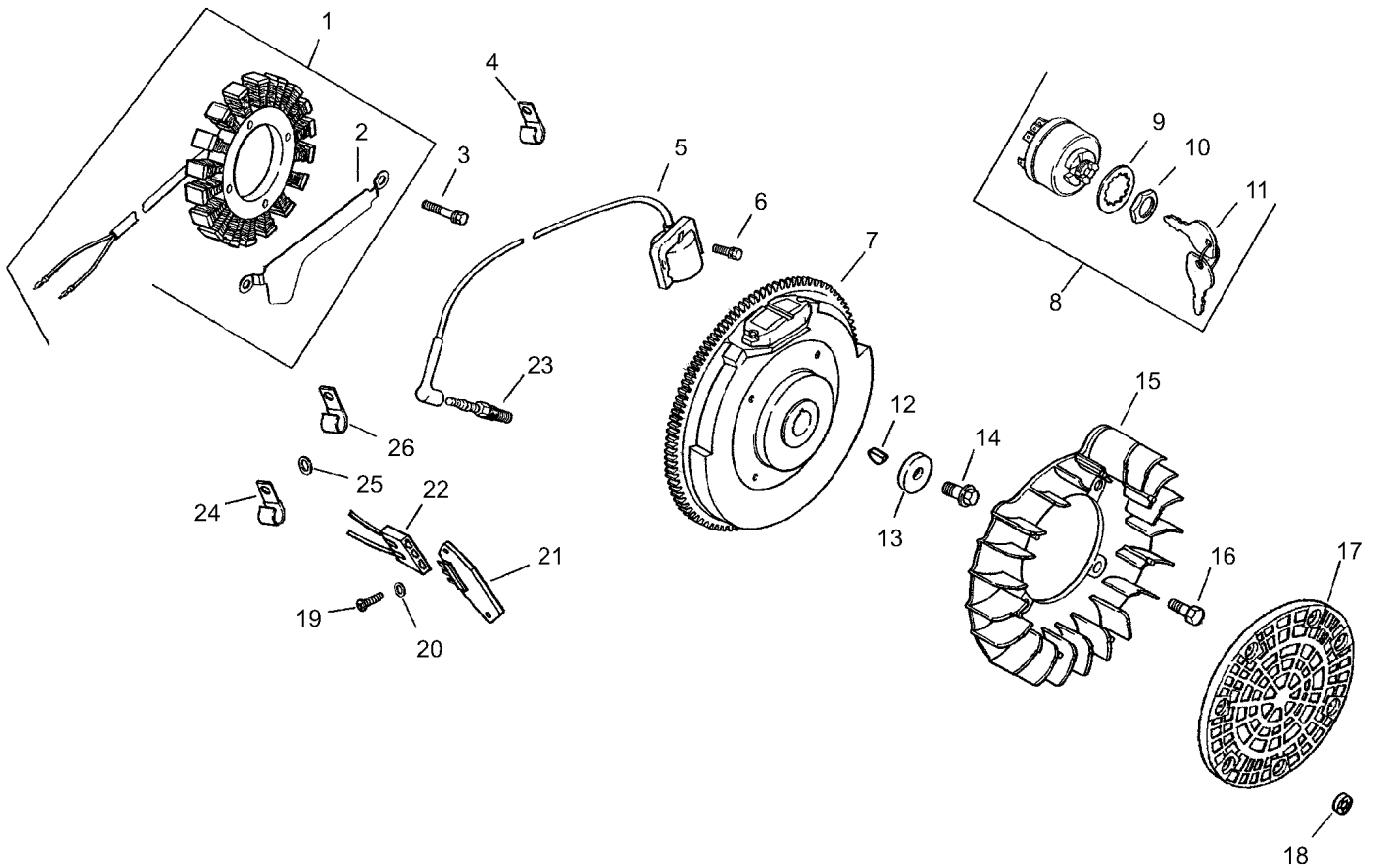

Ignition and Electrical Assembly Kohler CH23S-76546

Ref	Part No.	Qty.	Description
❶	54 755 09	1	Stator Kit, 15 Amp (Includes 2)
❷	24 126 71	1	Bracket-Wire, Stator
❸	M-548025	2	Screw-HH
❹	24 154 03	1	Clip-Cable
❺	24 584 01	2	Module-Ignition
❻	M-545020	4	Screw (M5X0.8X20)
❼	24 025 10	1	Flywheel
❽	25 099 04	1	Key Switch ASM (Includes 9-11)
❾	48 468 02	1	Washer
❿	48 100 01	1	Nut-Switch
⓫	48 340 01	1	Key (Set Of 2)
⓬	X-42-15	1	Key
⓭	12 468 03	1	Washer
⓮	12 086 14	1	Screw
⓯	24 157 01	1	Fan
⓰	25 086 47	4	Bolt-Shoulder
⓱	24 162 03	1	Screen-Grass
⓲	24 018 03	3	Retainer
⓳	24 086 18	2	Screw
⓴	X-25-92	2	Washer
⓵	25 403 03	1	Rectifier-Regulator
⓶	236602	1	Connector
⓷	12 132 02	2	Plug-Spark
⓸	235173	1	Clip

Ref	Part No.	Qty.	Description
⓶	X-25-63	1	Washer
⓶	48 154 02	1	Clip
⓷	24 518 12	1	Lead-Black
⓷	X-22-11	1	Washer
⓷	24 113 03	1	Decal-Switch, Key
⓷	54 755 02	1	Wire Harness Kit (Includes Items Listed Below)
⓷	15 452 01	2	Terminal
⓷	24 176 41	1	Lead-Duplex
⓷	24 176 50	1	Harness-Wiring
⓷	24 518 34	1	Lead-Violet
⓷	25 454 03	3	Tie-Cable

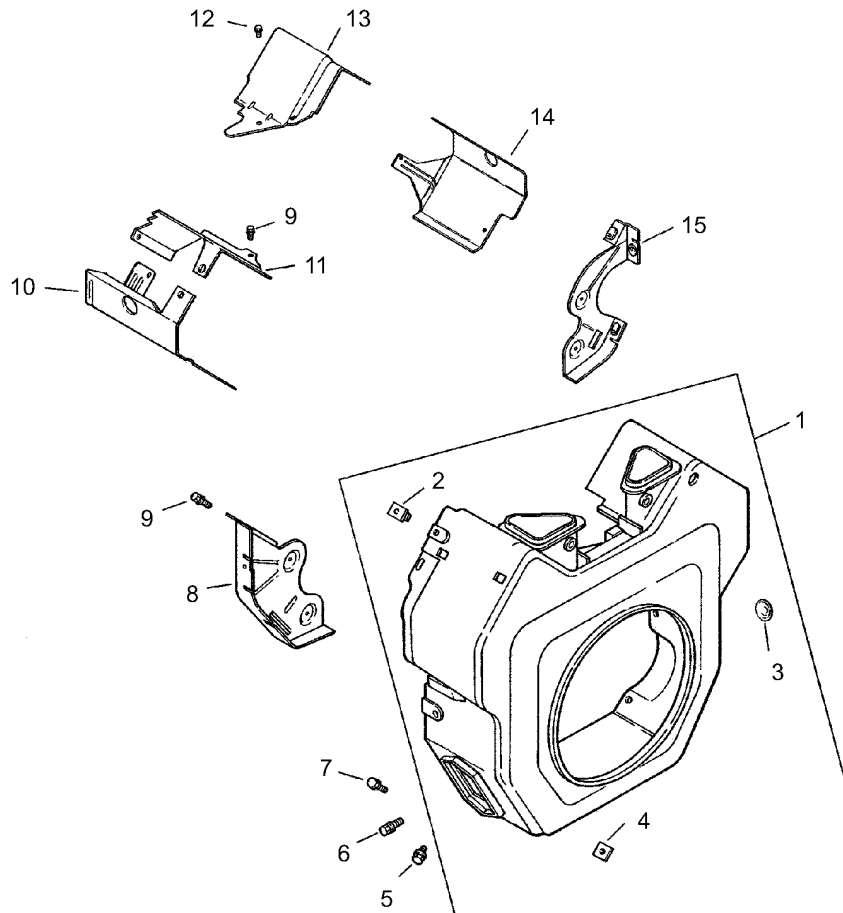

Blower Housing and Baffle Assembly Kohler CH23S-76546

Ref	Part No.	Qty.	Description				
1	24 027 20	1	Blower Housing ASM (Includes 2-4)				
2	24 100 02	2	Nut-Plastic				
3	25 139 16	1	Plug-Button				
4	24 100 01	3	Nut				
5	M-551016	1	Screw-HHF				
6	M-545016	3	Screw-HHF (M5X0.8X16)				
7	M-545020	4	Screw (M5X0.8X20)				
8	24 146 16	1	Plate-Backing, #2 Side				
9	M-645016	6	Screw-HHF				
10	24 063 20	1	Baffle-Cylinder, #2				
11	24 063 17	1	Baffle-Valley, #2 Side				
12	M-545010	2	Screw (M5X0.8X10)				
13	24 063 24	1	Baffle-Valley, #1 Side				
14	24 063 58	1	Baffle-Barrel, Cylinder (#1 Side)				
15	24 146 20	1	Plate-Backing, #1 Side				
16	24 146 33	1	Decal-23 Hp				

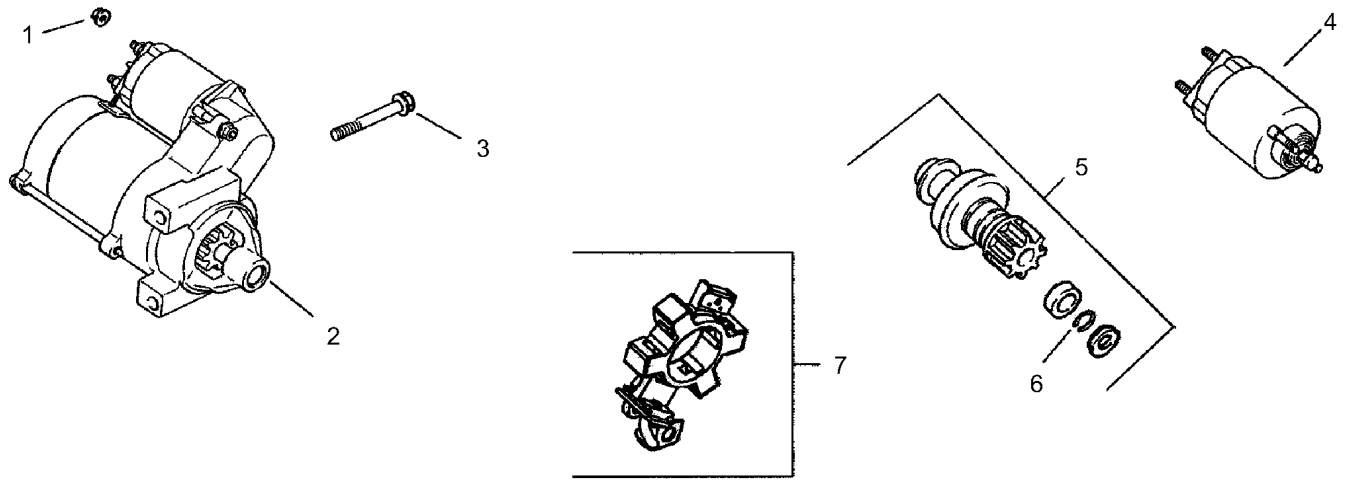

Starting System Assembly Kohler CH23S-76546

Ref	Part No.	Qty.	Description
❶	M-841080	1	Nut-Hex, Flange
❷	25 098 08	1	Starter And Solenoid Shift ASM (Includes 4-7)
❸	M-839080	2	Screw-HHF
❹	25 435 04	1	Solenoid Kit
❺	25 755 33	1	Pinion Drive Kit (Includes 6)
❻	25 141 05	1	Ring
❼	25 225 01	1	Brush Kit

--	--	--	--

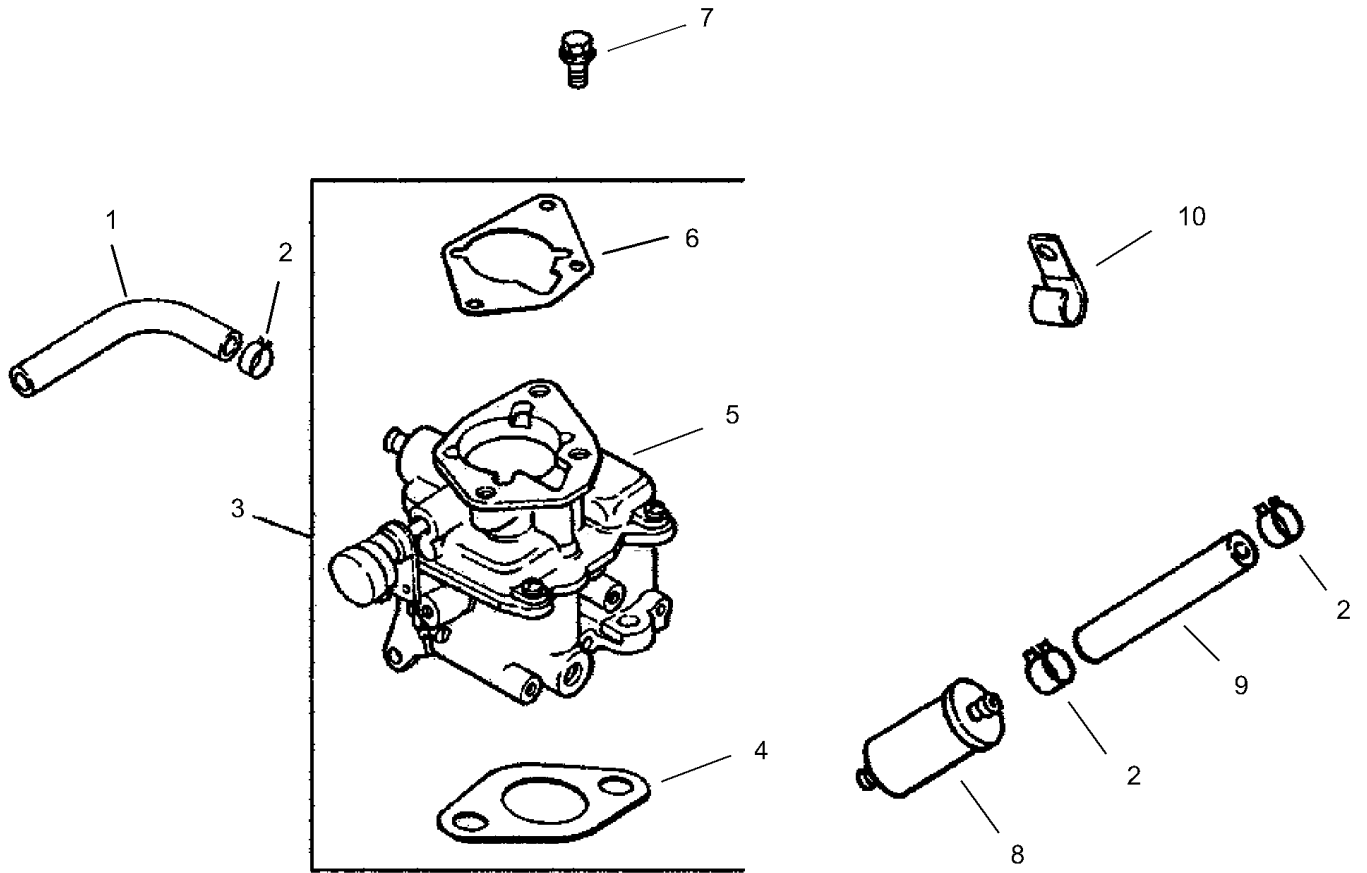

Fuel System Assembly Kohler CH23S-76546

Ref	Part No.	Qty.	Description
❶	24 353 12	1	Line-Fuel
❷	25 237 14	4	Clamp-Hose
❸	24 853 59	1	Carburetor Kit W/Gasket (Includes 4-6)
❹	24 041 17	1	Gasket
❺	24 053 59	1	Carburetor ASM
❻	24 041 06	1	Gasket
❼	M-651030	2	Screw-HHF
❽	24 050 02	1	Filter-Fuel
❾	24 353 11	1	Line-Fuel
❿	47 154 01	1	Clamp
⓫	24 757 01	1	Solenoid Kit (Includes The Following)
⓬	24 153 04	0	O-Ring
⓭	24 153 05	0	O-Ring
⓮	24 153 06	0	O-Ring
⓯		0	Seat-Solenoid
⓰		0	Solenoid And Solenoid Screw
⓱	24 757 02	1	Roat Repair Kit
⓲	24 757 03	1	Carburetor Repair Kit
⓳	24 153 04	0	O-Ring
⓴	24 153 05	0	O-Ring
⓵	24 153 06	0	O-Ring
⓶	24 757 07	1	Choke Repair Kit

--	--	--	--

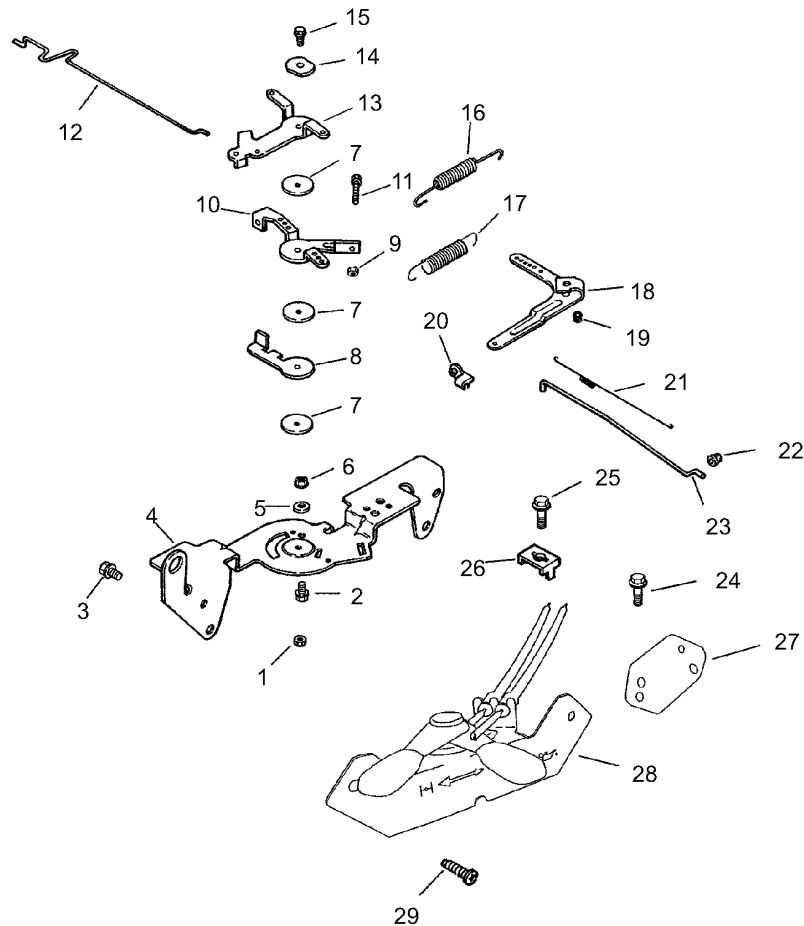

Engine Control Assembly Kohler CH23S-76546

Ref	Part No.	Qty.	Description
❶	M-547050	1	Nut-Hex
❷	M-545016	1	Screw-HHF (M5X0.8X16)
❸	M-645016	4	Screw-HHF
❹	24 126 56	1	Bracket-Control
❺	X-20-1	1	Washer
❻	M-541050	1	Nut-HF
❼	24 468 01	3	Washer
❽	24 090 07	1	Lever-Actuator, Throttle
❾	M-446030	1	Nut-Hex
❿	24 090 13	1	Lever-Control, Throttle
⓫	M-401030	1	Screw-HH
⓬	24 079 02	1	Linkage-Choke
⓭	24 090 05	1	Lever-Choke
⓮	41 468 03	1	Washer-Wave
⓯	M-545020	1	Screw (M5X0.8X20)
⓰	24 089 51	1	Spring-Limiter, Throttle
⓱	24 089 49	1	Spring-Governor
⓲	24 090 33	1	Lever-Governor
⓳	M-641060	1	Nut (M6X1.0)
⓴	25 158 08	1	Bushing-Linkage
⓵	24 089 01	1	Spring-Linkage
⓶	25 158 11	1	Bushing-Linkage
⓷	24 079 01	1	Linkage-Throttle
⓸	M-545010	2	Screw (M5X0.8X10)

Ref	Part No.	Qty.	Description
⓹	24 086 43	1	Screw-Set
⓺	12 237 01	1	Clamp
⓻	24 126 99	1	Bracket-Support, Cable
⓼	24 225 02	1	Control Cable ASM
⓽	24 211 03	1	Screw
⓿	24 113 92-S	1	Decal-Panel, Control

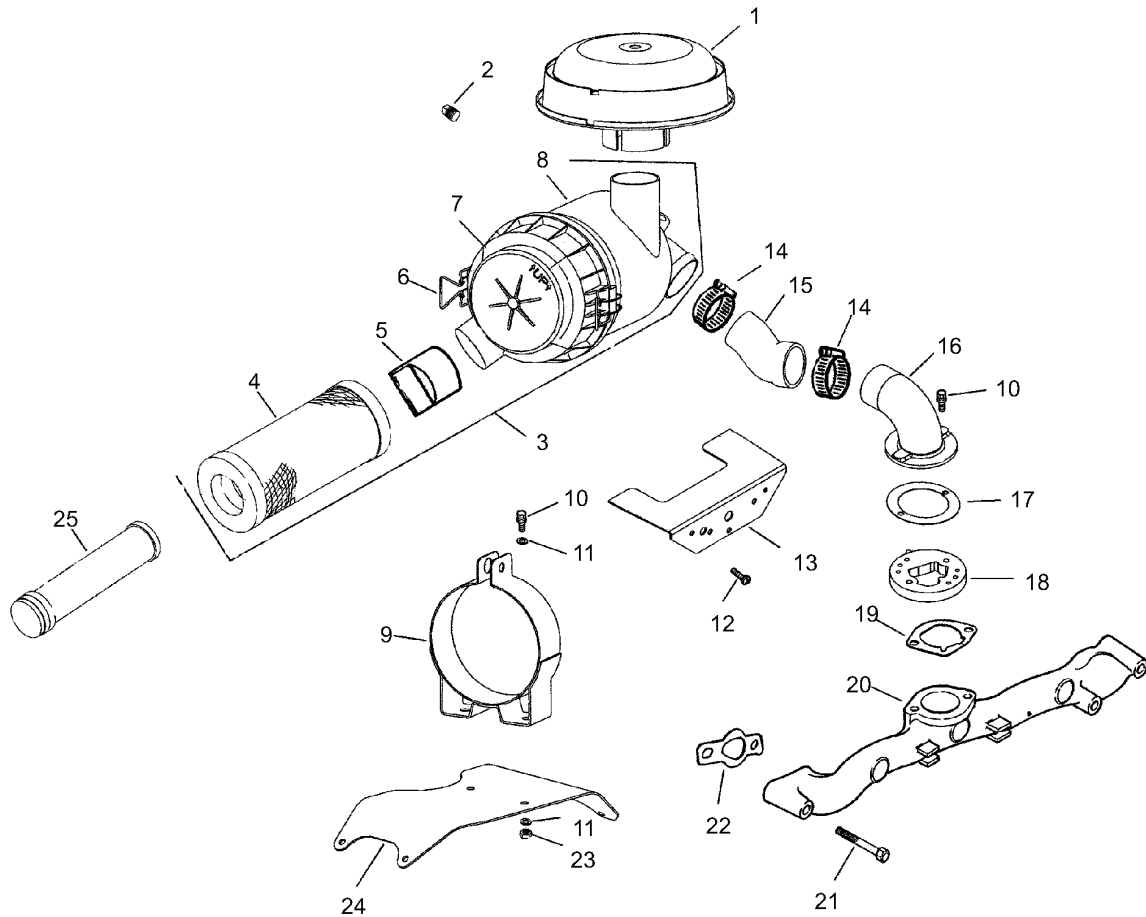

Air Intake and Filtration Assembly Kohler CH23S-76546

Ref	Part No.	Qty.	Description
❶	25 324 02	1	Hood
❷	25 139 20	1	Plug-Pipe
❸	25 048 07	1	Air Cleaner ASM (Includes 4-8)
❹	25 083 01	1	Element-A/C
❺	24 462 07	1	Valve-Ejector, Dust
❻	25 154 05	2	Clip
❼	25 096 06	1	Air Cleaner Cover ASM
❽	25 081 01	1	Housing-Air Cleaner, Heavy Duty
❾	25 126 02	1	Bracket-Air Cleaner
❿	M-639016	6	Screw-HHF
⓫	X-25-73	4	Washer
⓬	24 086 06	2	Screw
⓭	24 314 29	1	Shield-Debris
⓮	25 237 14	2	Clamp-Hose
⓯	24 326 32	1	Hose-Air Cleaner
⓰	24 029 21	1	Adapter-Air Cleaner, Remote
⓱	24 041 34	1	Gasket-Adapter
⓲	24 029 31	1	Adapter ASM
⓳	24 041 06	1	Gasket
⓴	24 164 14	1	Manifold
⓵	25 086 84	4	Screw-HF
⓶	24 041 01	2	Gasket-Intake, Manifold
⓷	M-647060	2	Nut-Hex
⓸	24 126 98	1	Bracket-Air Cleaner

Ref	Part No.	Qty.	Description
❶❷	25 083 04	1	Filter-Safety
❶❸	12 113 04	1	Decal-Air Cleaner

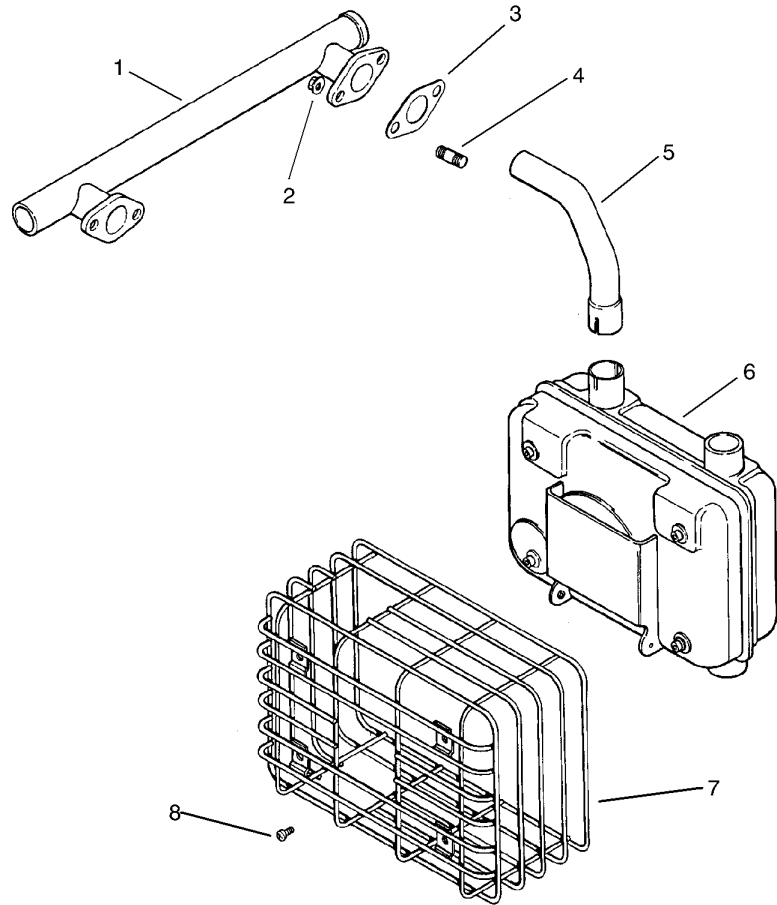

Exhaust Assembly Kohler CH23S-76546

Ref	Part No.	Qty.	Description	
1	24 164 11	1	Manifold-Exhaust	
2	M-841080	4	Nut-Hex, Flange	
3	24 041 02	2	Gasket-Exhaust	
4	25 072 04	4	Stud	
5	12 755 93	1	Gasket Set	
6	24 382 04	1	Pipe-Exhaust	
7	24 068 14	1	Muffler	
8	24 314 03	1	Guard-Muffler	
9	M-550010	4	Screw-Hex, Flange	
10	12 189 02	1	Spark Arrestor (Optional)	

NOTES

NOTES

NOTES

