



TimeCutter™ Z5000 Riding Mower

Model No. 74370 - 280000001 and up.

Parts Catalog

Ordering Replacement Parts

To order replacement parts, please supply the part number, the quantity, and the description of each part desired.

Understanding Reference Numbers

Each identified part in an illustration has a reference number. The reference number for a part also appears in the parts list, along with other information about the part.

This catalog uses two special reference number formats, one to indicate parts in a service assembly and another to indicate the quantity of a given part in an illustration.

Service Assembly Reference Numbers

Parts in service assemblies have reference numbers in the form a:b. The a represents the reference number of the entire service assembly and the b represents a sequential number unique to each part within the service assembly.

For example, a wheel assembly might be identified by reference number 6, the tire by 6:1, the valve by 6:2, and the wheel by 6:3. When you order the assembly identified by reference number 6, you receive all parts identified by reference numbers 6:1, 6:2, and 6:3. However, you may also order any part individually. Reference numbers of this type appear in illustrations and in part lists.

Reference Numbers Indicating Quantity

In an illustration, if a reference number indicates more than one part, the reference number has the form nX y. The n represents the quantity of the part, the X is the multiplication symbol, and the y represents the reference number.

For example, in an illustration, the reference number 2X 37 means that two of the parts identified by reference number 37 are indicated.

Contents

Description	Page	Description	Page
Frame Assembly 3	Oil Pan and Lubrication Assembly Kohler SV610-0020 18
Deck Lift and Seat Support Assembly 4	Head, Valve and Breather Assembly Kohler SV610-0020 19
Seat Assembly 5	Ignition and Electrical Assembly Kohler SV610-0020 20
Control Assembly 6	Blower Housing Assembly Kohler SV610-0020 21
Hydro Drive Assembly 7	Starter Assembly Kohler SV610-0020 22
RH Hydro Assembly No. 110-6771 8	Fuel System Assembly Kohler SV610-0020 23
LH Hydro Assembly No. 110-6770 9	Engine Control Assembly Kohler SV610-0020 24
Engine and Clutch Assembly 10	Air Intake and Filtration Assembly Kohler SV610-0020 25
Styling and Fuel System Assembly 11	Exhaust Stud, Gasket and Decal Assembly Kohler SV610-0020 26
50 Inch Deck and Side Discharge Assembly 12	Attachments and Accessories List 27
50 Inch Deck Assembly No. 110-6790 13		
50 Inch Deck Spindle and Belt Drive Assembly 14		
Electrical Assembly 15		
Crankshaft Assembly Kohler SV610-0020 16		
Crankcase Assembly Kohler SV610-0020 17		

Part Description Abbreviations

Part descriptions in this catalog may include the following abbreviations.

AR. as required	HYD. hydraulic
ASM. assembly	LH. left hand
BBC. blade brake clutch	NI. nylon insert
CARR. carriage	NPTF. national pipe thread fine
DEG. degrees	PFH. phillips flat head
EXT. external	PPH. phillips pan head
FH. flat head	PPHTF. phillips pan head thread forming
GA. gauge	PRH. phillips round head
HD. heavy-duty	PTH. phillips truss head
HF. hex flange	PTO. power-take-off
HH. hex head	RH. right hand
HHF. hex head flange	ROPS. roll-over protection system
HHFTF. hex head flange thread forming	SFH. slotted fillister head
HJ. hex jam	SHH. slotted hex head
HLH. hex lag head	SHWH. slotted hex washer head
HOC. height-of-cut	SPH. slotted pan head
HSBH. hex socket button head	SQH. square head
HSFH. hex socket flat head	SRH. slotted round head
HSH. hex socket head	STD. standard
HWH. hex washer head	TAP. self tapping
HWHTF. hex washer head thread forming	TTH. torx truss head

Footnotes

- ❶ Not illustrated
- ❷ Not serviced separately
- ❸ Obtain from your local Kohler dealer

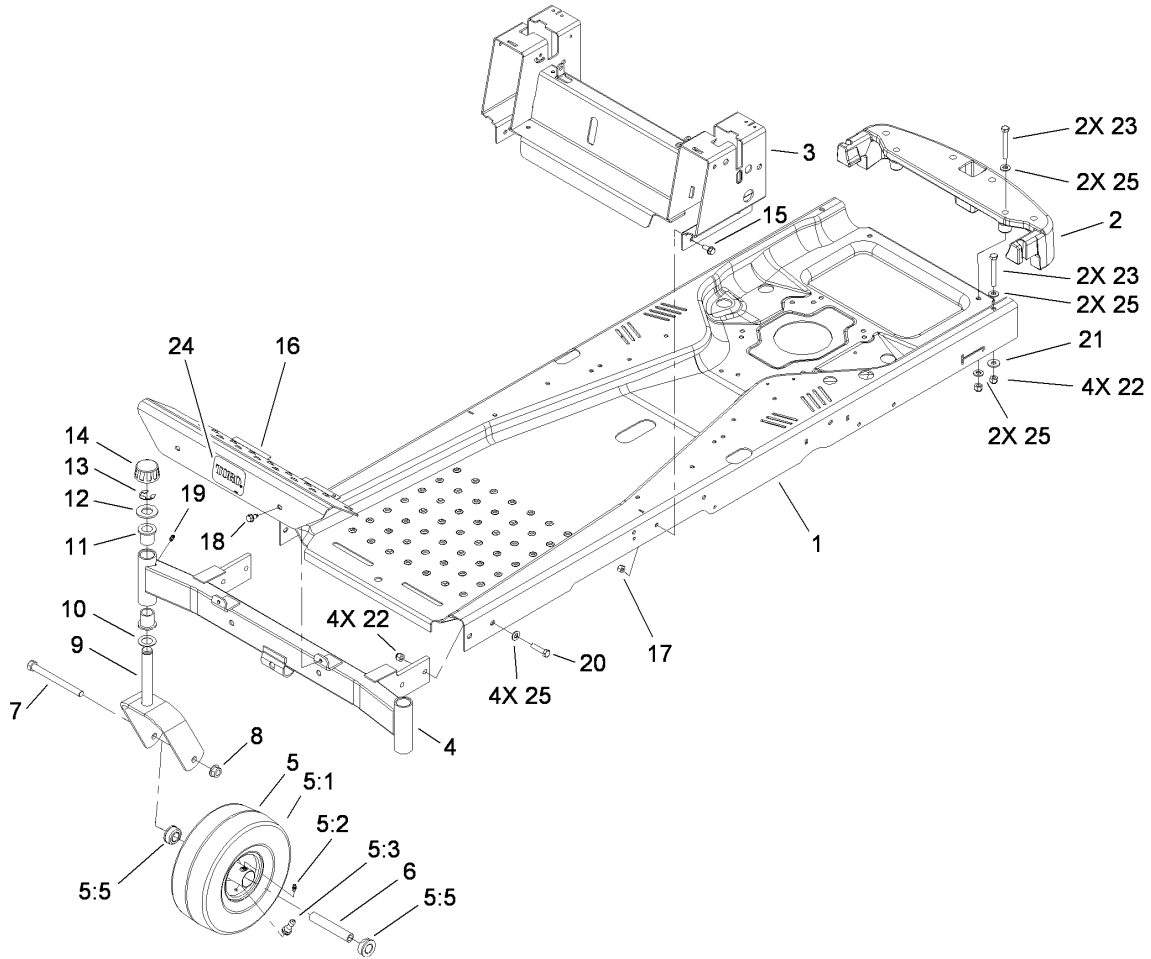

Frame Assembly

Ref	Part No.	Qty.	Description
1	115-2464-01	1	Frame
2	110-6899-03	1	Bumper-Rear
3	115-2468-03	1	Seat/Control ASM
4	108-7882-01	1	Front Axle ASM
5	110-6785	2	Castor Wheel ASM
5:1	110-6791	1	Tire-Smooth
5:2	302-5	1	Fitting-Grease
5:3	232-27	1	Stem-Valve
5:5	114-1640	2	Bushing-Flange
5:99	93-4244	1	Tube-Inner (W/Valve)
6	104-3667	2	Spanner-Wheel
7	325-22	2	Screw-HH
8	32128-23	2	Nut-HF
9	108-7851-01	2	Caster Fork ASM
10	110-6767	2	Washer-Thrust
11	1-303514	4	Bearing-Flanged
12	104-8076	2	Washer
13	32151-103	2	Ring-Retaining, EXT
14	61-9780	2	Cap-Hub
15	3234-47	7	Screw-HHF
16	108-7855-03	1	Footrest
17	3296-29	7	Nut-Lock, NI
18	32104-32	2	Screw-HWH
19	302-5	2	Fitting-Grease

Ref	Part No.	Qty.	Description
20	323-8	4	Screw-HH
21	80-6990	2	Washer-Hardened
22	3296-39	8	Nut-Lock, NI
23	323-13	4	Screw-HH
24	99-2385	1	Decal
25	3256-24	10	Washer-Flat

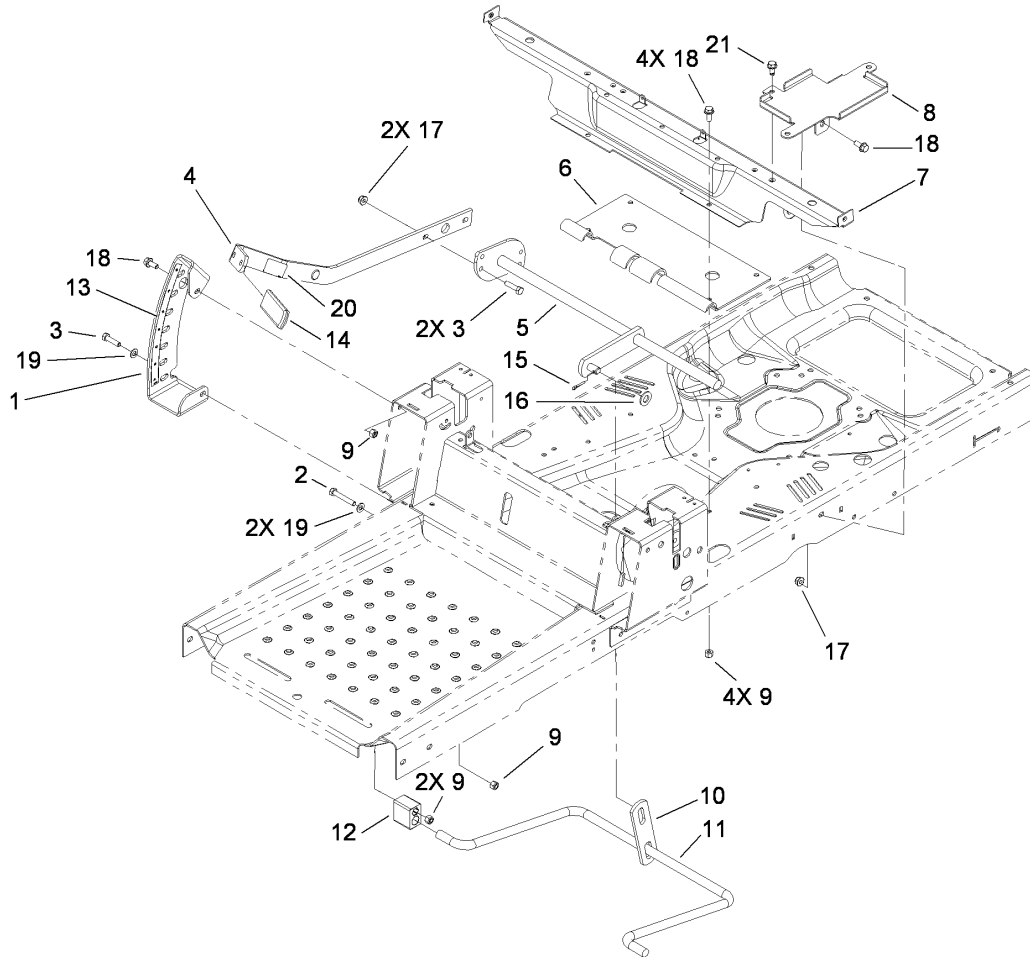

Deck Lift and Seat Support Assembly

Ref	Part No.	Qty.	Description
1	112-4027-03	1	Sector-HOC
2	322-10	2	Screw-HH
3	322-6	3	Screw-HH
4	112-3960-03	1	Lift Arm ASM
5	108-7841-03	1	Lift Lever ASM
6	110-6800-03	1	Plate-Lift
7	110-6805-03	1	Bracket-Seat/Pods
8	110-1937-03	1	Tray-Battery
9	3296-29	8	Nut-Lock, NI
10	108-7840	1	Link-Lift
11	108-7839	1	Arm-Lift, Rear
12	108-7845	2	Block-Pivot
13	112-9802	1	Decal-HOC
14	105-3450	1	Grip-Lever, Lift
15	3272-10	1	Pin-Cotter
16	3256-26	1	Washer-Flat
17	104-8300	3	Nut-Flange, NI
18	3234-47	6	Screw-HHF
19	3256-23	3	Washer-Flat
20	106-8743	1	Decal
21	32104-32	1	Screw-HWH

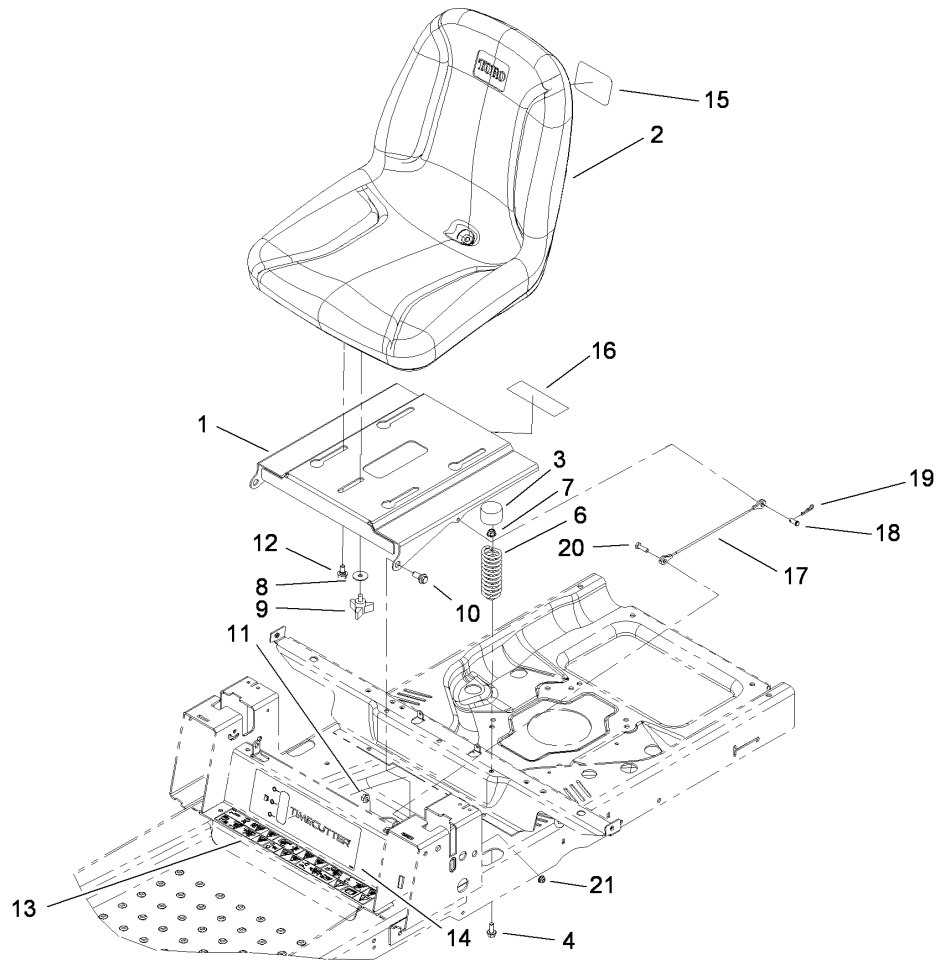

Seat Assembly

Ref	Part No.	Qty.	Description				
1	115-2465-03	1	Base-Seat				
2	110-6772	1	Seat-18 Inch				
3	701178	2	Cap-Protector				
4	3234-47	2	Screw-HHF				
6	92-7054	2	Spring-Compression				
7	104-8300	2	Nut-Flange, NI				
8	5-4460	1	Washer-Pivot				
9	92-9674	1	Knob				
10	94-7582	2	Bolt-Shoulder				
11	32128-21	2	Nut-HF				
12	37-8771	4	Bolt-Shoulder				
13	115-2469	1	Decal-Danger				
14	115-2451	1	Decal-Timecutter				
15	99-2385	1	Decal				
16	106-8717	1	Decal-Service				
17	109-2628	1	Cable-Stop, Seat				
18	60-1730	1	Pin-Clevis				
19	1-806003	1	Pin-Hair				
20	321-5	1	Screw-HH				
21	104-7201	1	Nut-HF				

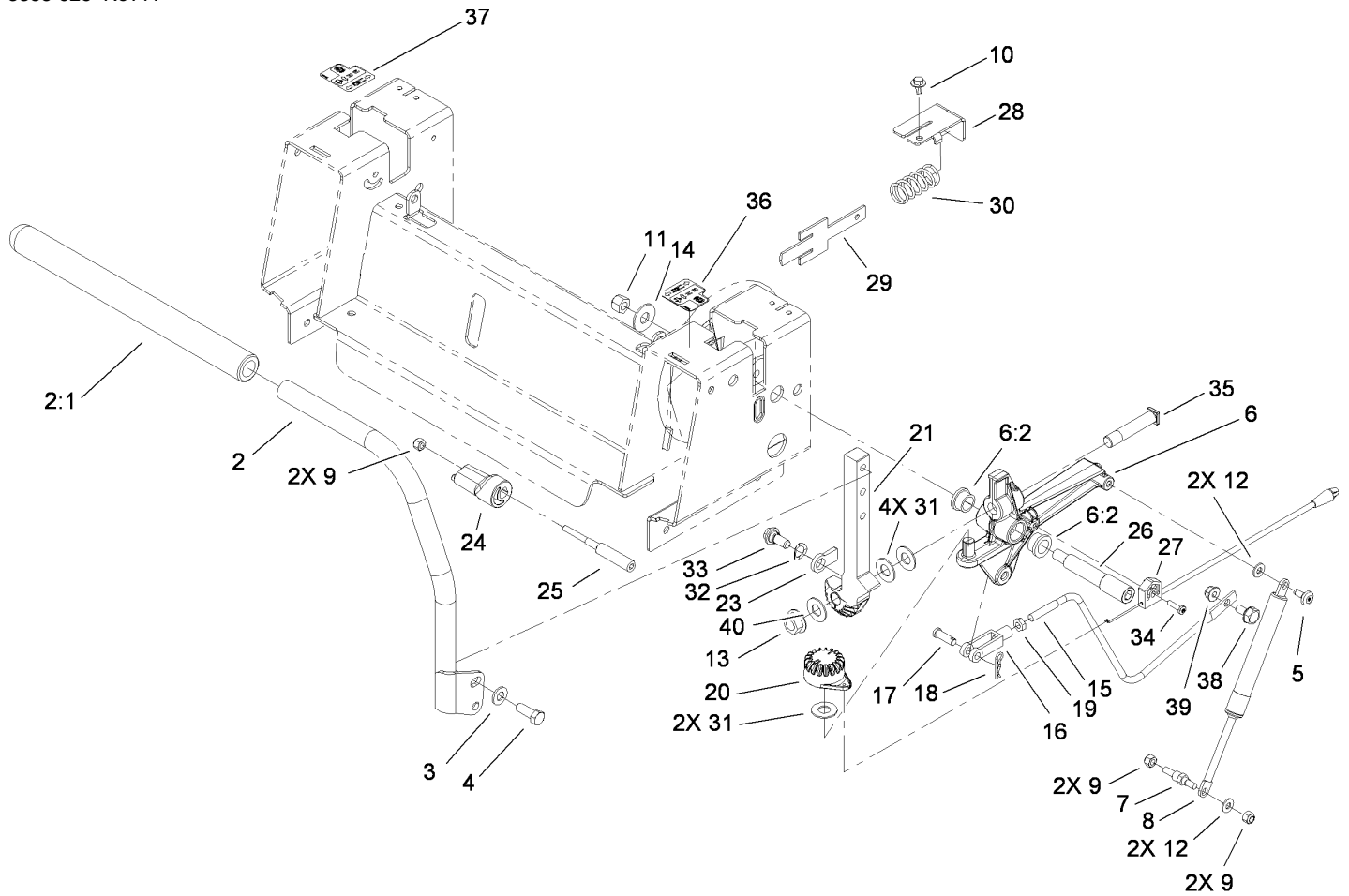

Control Assembly

Ref	Part No.	Qty.	Description
1	110-6814	1	RH Handle ASM
1:1	108-6187	1	Grip
2	110-6815	1	LH Handle ASM
2:1	108-6187	1	Grip
3	3256-24	4	Washer-Flat
4	323-6	4	Screw-HH
5	112-4004	2	Screw-Shoulder
6	110-6828	2	Activator Arm ASM
6:2	105-3455	2	Bushing
7	110-6810	2	Stud-Damper
8	103-2913	2	Damper-Control, Motion
9	3296-42	6	Nut-Lock, NI
10	46-8560	2	Screw-HHF
11	3296-48	2	Nut-Lock, NI
12	3256-22	4	Washer-Flat
13	32128-23	2	Nut-HF
14	3256-5	2	Washer-Flat
15	110-6693	2	Link-Hydro
16	1-303105	2	Yoke-Adjustable
17	1-808280	2	Pin-Clevis
18	1-806003	2	Pin-Hair
19	3220-2	2	Nut-Jam
20	110-6845	2	Gear-Control
21	110-6783	1	Arm-Actuator, LH

Ref	Part No.	Qty.	Description
22	110-6782	1	Arm-Actuator, RH
23	110-6856	2	Tab-Stop
24	110-6873	2	Eccentric
25	110-6874	2	Screw-Eccentric
26	110-6875	2	Bolt-Shoulder
27	110-6858	2	Cable-Brake, Parking
28	110-6751	2	Bracket-Return
29	110-6750	2	Plate-Return
30	110-6752	2	Spring
31	110-6894	6	Washer-Pivot
32	3290-221	2	Washer-Spring
33	94-7582	2	Bolt-Shoulder
34	110-0863	2	Screw-Torx
35	110-6784	2	Bolt-Shoulder
36	112-9750	1	Decal-Control Lever, LH
37	112-9751	1	Decal-Control Lever, RH
38	37-8771	2	Bolt-Shoulder
39	104-8300	2	Nut-Flange, NI
40	112-9771	2	Washer-Teflon

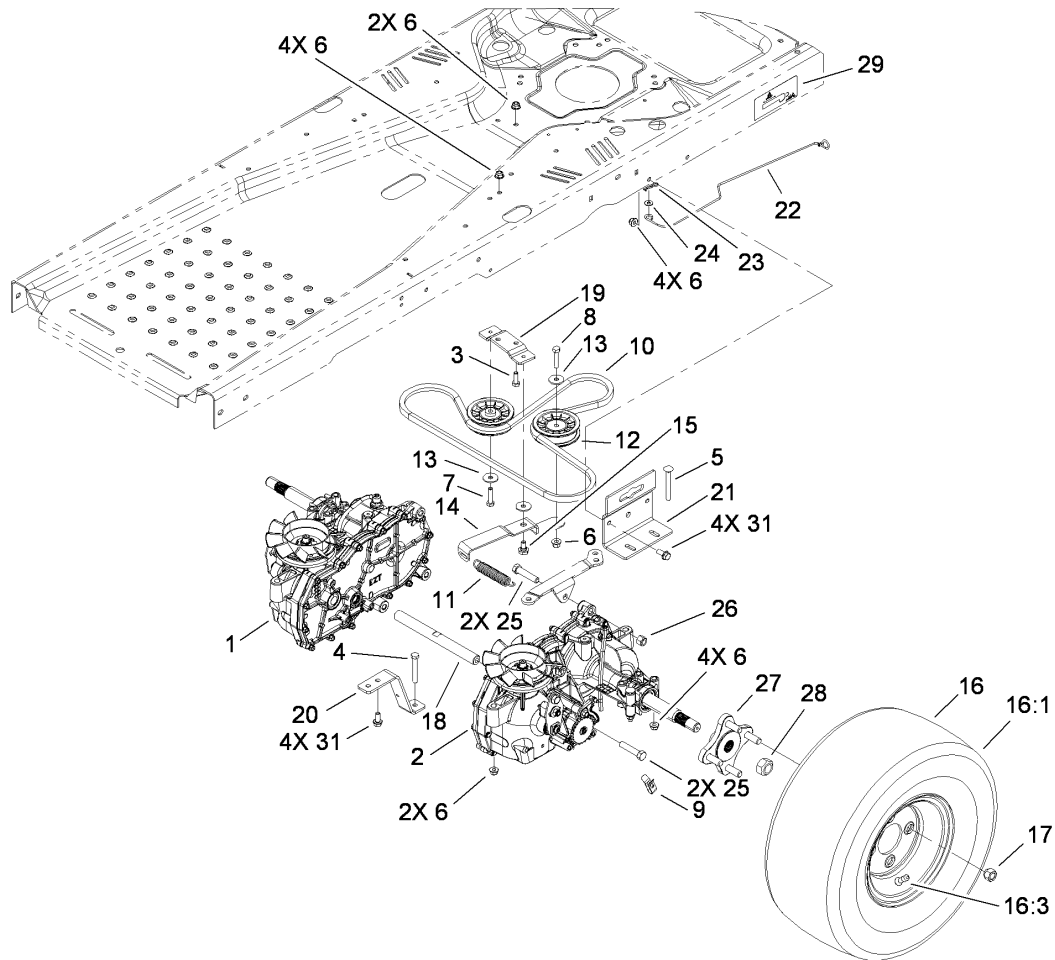

Hydro Drive Assembly

Ref	Part No.	Qty.	Description
1	110-6771	1	Hydro-RH
2	110-6770	1	Hydro-LH
3	322-4	2	Screw-HH
4	322-11	2	Screw-HH
5	3230-9	4	Screw-CARR
6	104-8300	17	Nut-Flange, NI
7	322-6	1	Screw-HH
8	322-7	1	Screw-HH
9	110-6677	2	Clip-Spring
10	110-6774	1	V-Belt
11	63-1590	1	Spring-Idler
12	110-6775	2	Pulley-Idler
13	5-4460	3	Washer-Pivot
14	110-1925	1	Arm-Idler
15	37-8771	1	Bolt-Shoulder
16	110-6883	2	Wheel And Tire ASM
16:1	110-6887	1	Tire
16:3	232-27	1	Stem-Valve
●16:99	232-37	1	Tube
17	242-50	8	Nut-Lug
18	110-6807	1	Shaft-Cross
19	110-1926	1	Plate-Pivot
20	110-6806-03	2	Strap-Torque
21	110-6878-03	2	Support-Hydro

Ref	Part No.	Qty.	Description
22	110-6787	2	Rod-Bypass
23	1-806003	2	Pin-Hair
24	3256-22	2	Washer-Flat
25	324-8	4	Screw-HH
26	3296-48	2	Nut-Lock, NI
27	112-3979	2	Hub ASM
28	112-3982	2	Nut-Lock
29	114-8532	1	Decal-Transport, LH
●30	114-8531	1	Decal-Transport, RH
31	3234-47	8	Screw-HHF

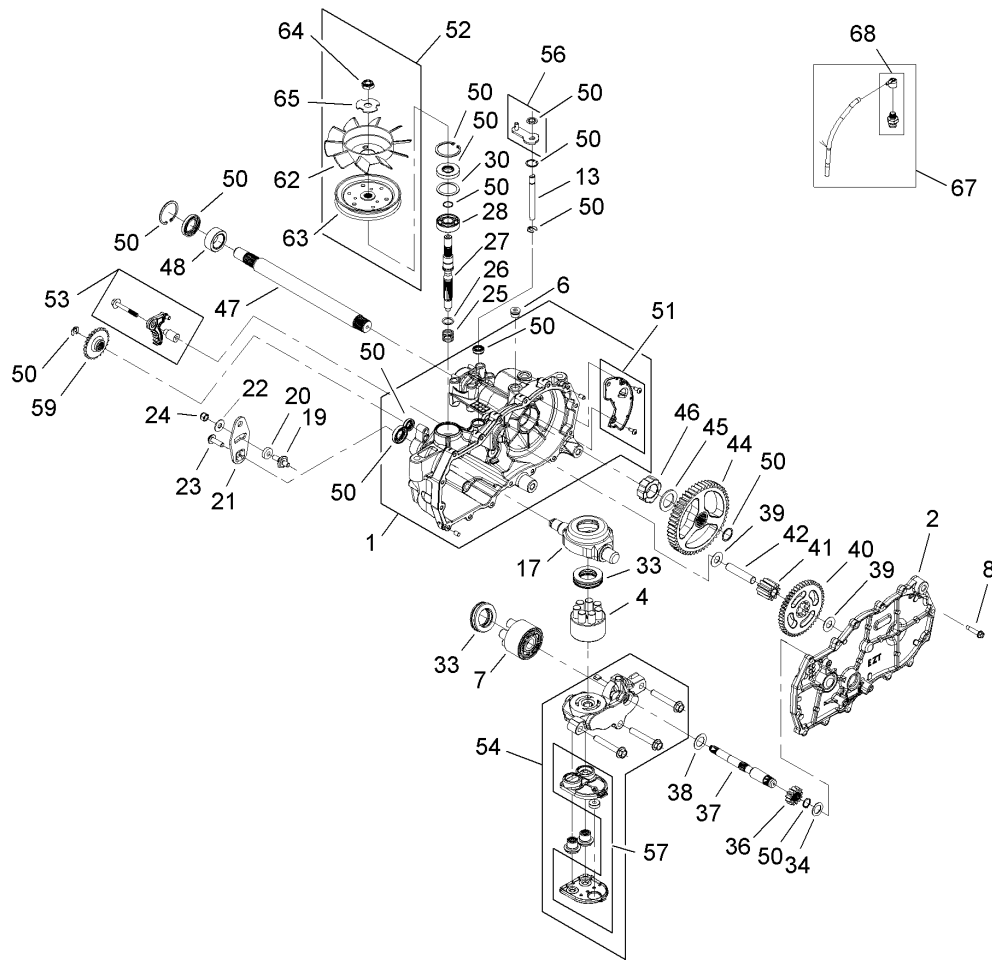

RH Hydro Assembly No. 110-6771

Ref	Part No.	Qty.	Description
1	114-1630	1	RH Main Housing ASM
2	114-1631	1	RH Side ASM
4	110-8561	1	Pump Block ASM
6	112-9850	1	Plug
7	103-2666	1	Cylinder Block Kit
8	104-5305	16	Screw-HHF
13	106-8678	1	Rod-Bypass
17	104-5304	1	Swashplate-Trunnion
19	104-2116	1	Stud
20	112-9853	1	Puck-Friction
21	106-8747	1	Arm-Control
22	5-4460	1	Washer-Pivot
23	107-2488	1	Screw
24	105-1872	1	Nut
25	94-1936	1	Spring-Block
26	94-1937	1	Washer-Block, Thrust
27	104-5306	1	Shaft-Input
28	104-5311	1	Bearing-Ball
30	104-5308	1	Spacer
33	94-6922	2	Bearing-Thrust
34	104-5339	1	Washer-Flat
36	104-5316	1	Gear-Pinnion, 13T
37	114-1632	1	Shaft, Motor
38	104-5360	1	Washer-Shaft, Motor

Ref	Part No.	Qty.	Description
39	94-1933	2	Washer
40	104-5317	1	Gear
41	104-5318	1	Gear-Jackshaft, 10T
42	104-5329	1	Pin-Jackshaft
44	112-9855	1	Gear-52T Bull
45	112-9856	1	Washer
46	112-9857	1	Bearing-Sleeve
47	112-9858	1	Shaft-Axle
48	112-9859	1	Bushing-Axle
50	106-8686	1	Seal Kit
51	106-8697	1	RH Expansion Plate Kit
52	106-8698	1	Fan Pulley Kit
53	114-1633	1	Brake Arm Kit
54	112-9861	1	RH Center Section Filter Kit
55	104-2147	1	Sealant
56	107-2489	1	Bypass Arm Kit
57	114-1634	1	Filter Kit
59	106-8694	1	Disc-Brake, Cog
62	110-8566	1	Fan-6 Inch, 10 Blade
63	104-1754	1	Pulley
64	105-1875	1	Nut-Lock
65	107-9122	1	Washer-Slotted
67	112-9866	1	Breather Kit
68	114-1635	1	Breather ASM

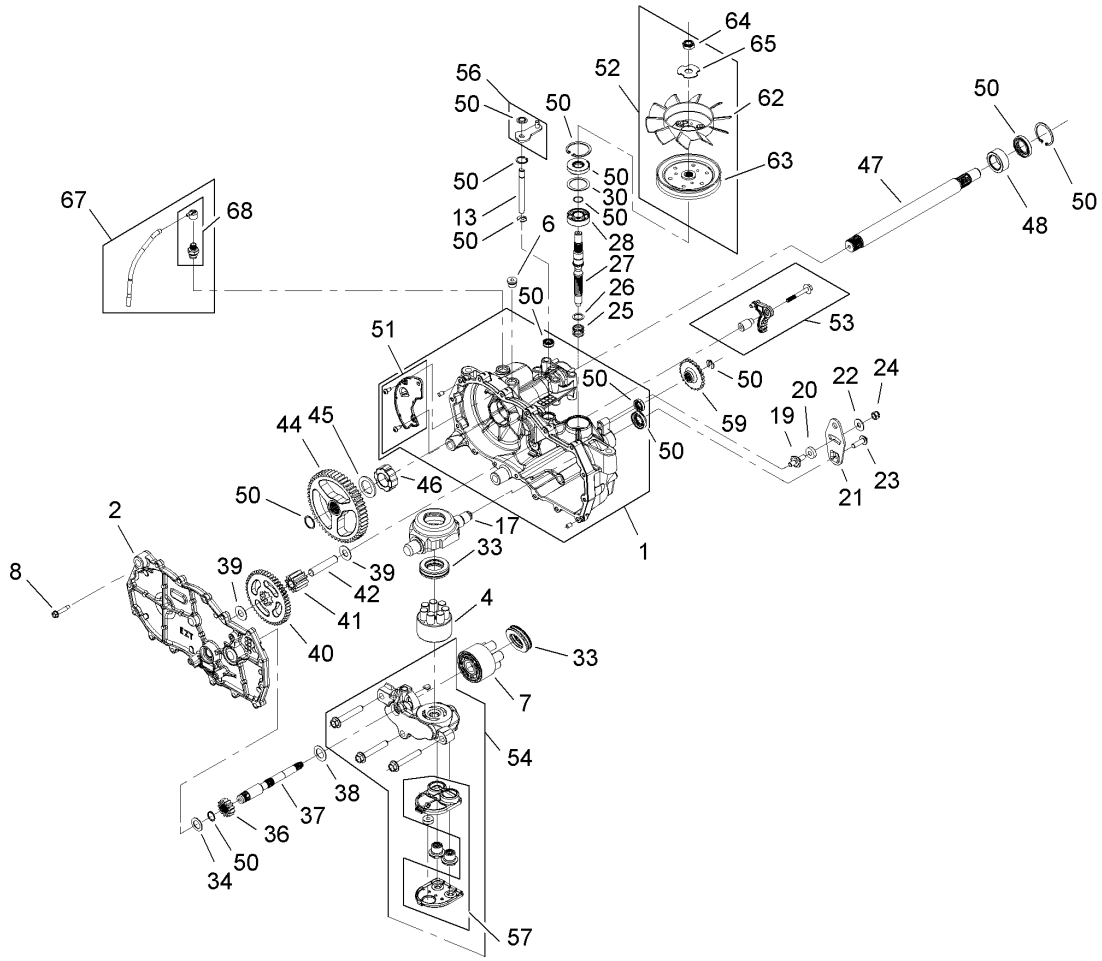

LH Hydro Assembly No. 110-6770

Ref	Part No.	Qty.	Description
1	114-1636	1	LH Main Housing ASM
2	114-1637	1	LH Side ASM
4	110-8561	1	Pump Block ASM
6	112-9850	1	Plug
7	103-2666	1	Cylinder Block Kit
8	104-5305	16	Screw-HHF
13	106-8678	1	Rod-Bypass
17	104-5304	1	Swashplate-Trunnion
19	104-2116	1	Stud
20	112-9853	1	Puck-Friction
21	106-8747	1	Arm-Control
22	5-4460	1	Washer-Pivot
23	107-2488	1	Screw
24	105-1872	1	Nut
25	94-1936	1	Spring-Block
26	94-1937	1	Washer-Block, Thrust
27	104-5306	1	Shaft-Input
28	104-5311	1	Bearing-Ball
30	104-5308	1	Spacer
33	94-6922	2	Bearing-Thrust
34	104-5339	1	Washer-Flat
36	104-5316	1	Gear-Pinnion, 13T
37	114-1632	1	Shaft, Motor
38	104-5360	1	Washer-Shaft, Motor

Ref	Part No.	Qty.	Description
39	94-1933	2	Washer
40	104-5317	1	Gear
41	104-5318	1	Gear-Jackshaft, 10T
42	104-5329	1	Pin-Jackshaft
44	112-9855	1	Gear-52T Bull
45	112-9856	1	Washer
46	112-9857	1	Bearing-Sleeve
47	112-9858	1	Shaft-Axle
48	112-9859	1	Bushing-Axle
50	106-8686	1	Seal Kit
51	106-8687	1	LH Expansion Plate Kit
52	106-8698	1	Fan Pulley Kit
53	114-1633	1	Brake Arm Kit
54	112-9862	1	LH Center Section Filter Kit
55	104-2147	1	Sealant
56	107-2489	1	Bypass Arm Kit
57	114-1634	1	Filter Kit
59	106-8694	1	Disc-Brake, Cog
62	110-8566	1	Fan-6 Inch, 10 Blade
63	104-1754	1	Pulley
64	105-1875	1	Nut-Lock
65	107-9122	1	Washer-Slotted
67	112-9866	1	Breather Kit
68	114-1635	1	Breather ASM

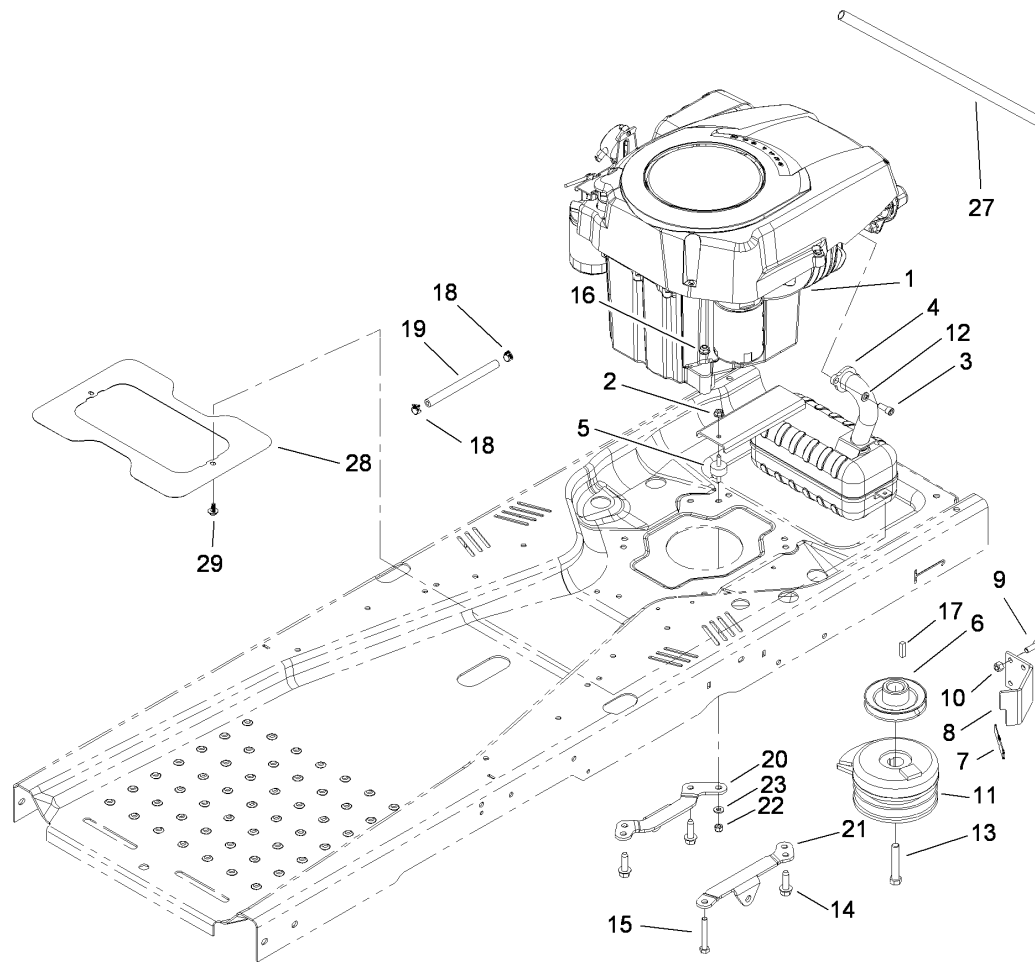

Engine and Clutch Assembly

Ref	Part No.	Qty.	Description
1		1	Engine-Kohler, Sv610-0020
2	32128-33	1	Nut-HF
3	3274-10	2	Screw-HSH
4	112-4024	1	Muffler-Kohler
5	112-3976	1	Isolator
6	110-6758	1	Pulley-Engine
7	112-4033	1	Bumper
8	110-6896	1	Stop-Clutch
9	322-4	2	Screw-HH
10	3296-29	2	Nut-Lock, NI
11	110-6766	1	Clutch-Electric, PTO
12	3253-4	2	Washer-Lock
13	3212-11	1	Screw-HH
14	32144-109	3	Screw
15	322-11	1	Screw-HH
16	104-8300	1	Nut-Flange, NI
17	5-7280	1	Key
18	2412-98	2	Clamp
19	109-0306	1	Hose-Fuel
20	110-6798	1	Support-Hydro, RH
21	110-6799	1	Support-Hydro, LH
22	3296-42	1	Nut-Lock, NI
23	3256-22	1	Washer-Flat
27	106-7022	1	Tube-Drain, Oil

Ref	Part No.	Qty.	Description
28	114-8544	1	Shield-Heat
29	46-8560	2	Screw-HHF

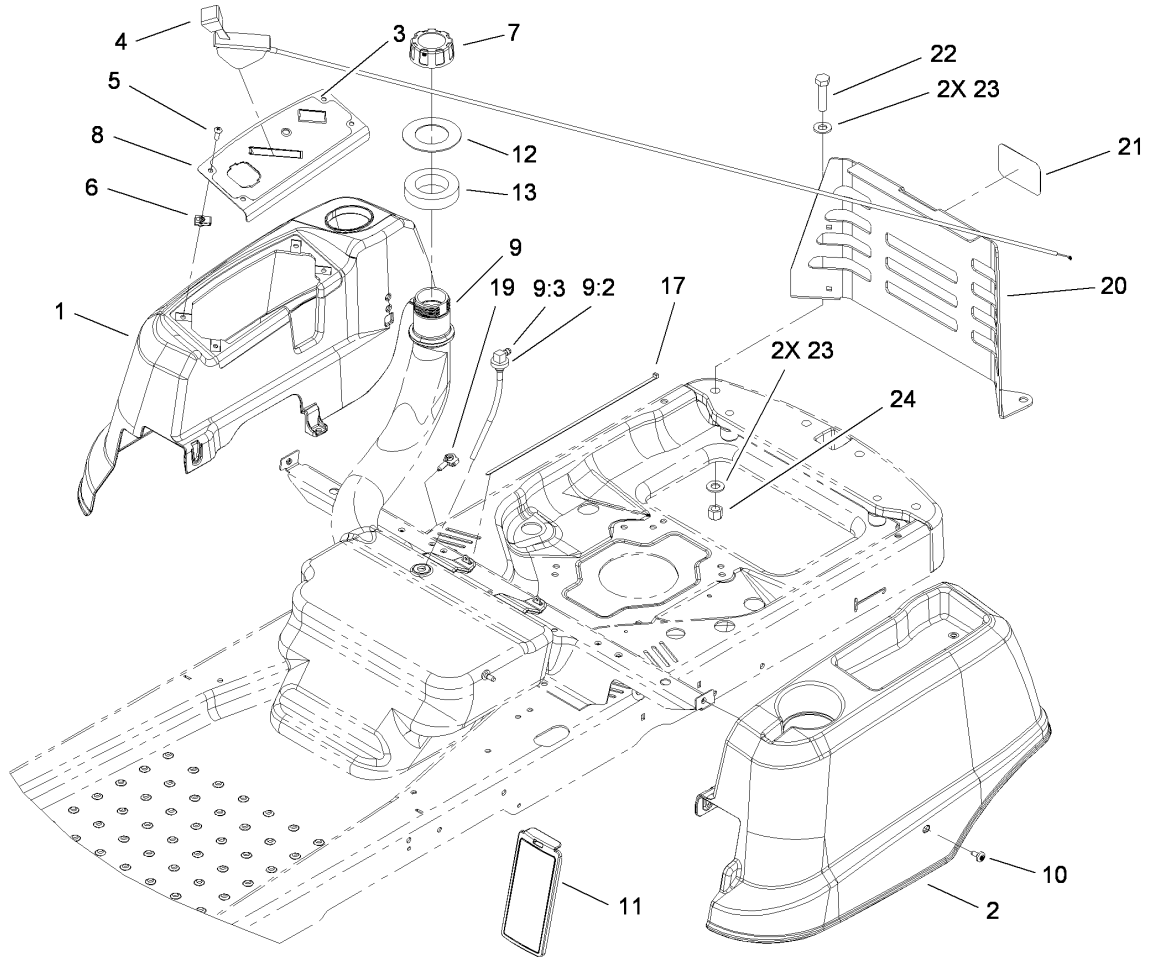

Styling and Fuel System Assembly

Ref	Part No.	Qty.	Description
1	110-1901	1	Pod-RH
2	110-1902	1	Pod-LH
3	115-2500	1	Decal-Panel, Control
4	104-3626	1	Cable-Throttle
5	3258-166	4	Screw-PRH
6	107069	4	Clip
7	93-7198	1	Gas Cap ASM
8	110-1927-03	1	Panel-Control
9	110-6890	1	Fuel Tank ASM
9:2	46-6560	1	Bushing
9:3	95-3970	1	Fitting-90 Degree
10	112-4004	6	Screw-Shoulder
11	110-6786	2	Cover-Control
12	112-9760	1	Washer-Rubber
13	55-9310	1	Seal-Foam
17	100-9064	1	Tie-Cable
19	32180-037	1	Clip-Harness
20	110-6685-03	1	Support-Cover, Rear
21	99-2385	1	Decal
22	325-8	2	Screw-HH
23	3256-26	4	Washer-Flat
24	3296-23	2	Nut-Lock, NI

--	--	--	--

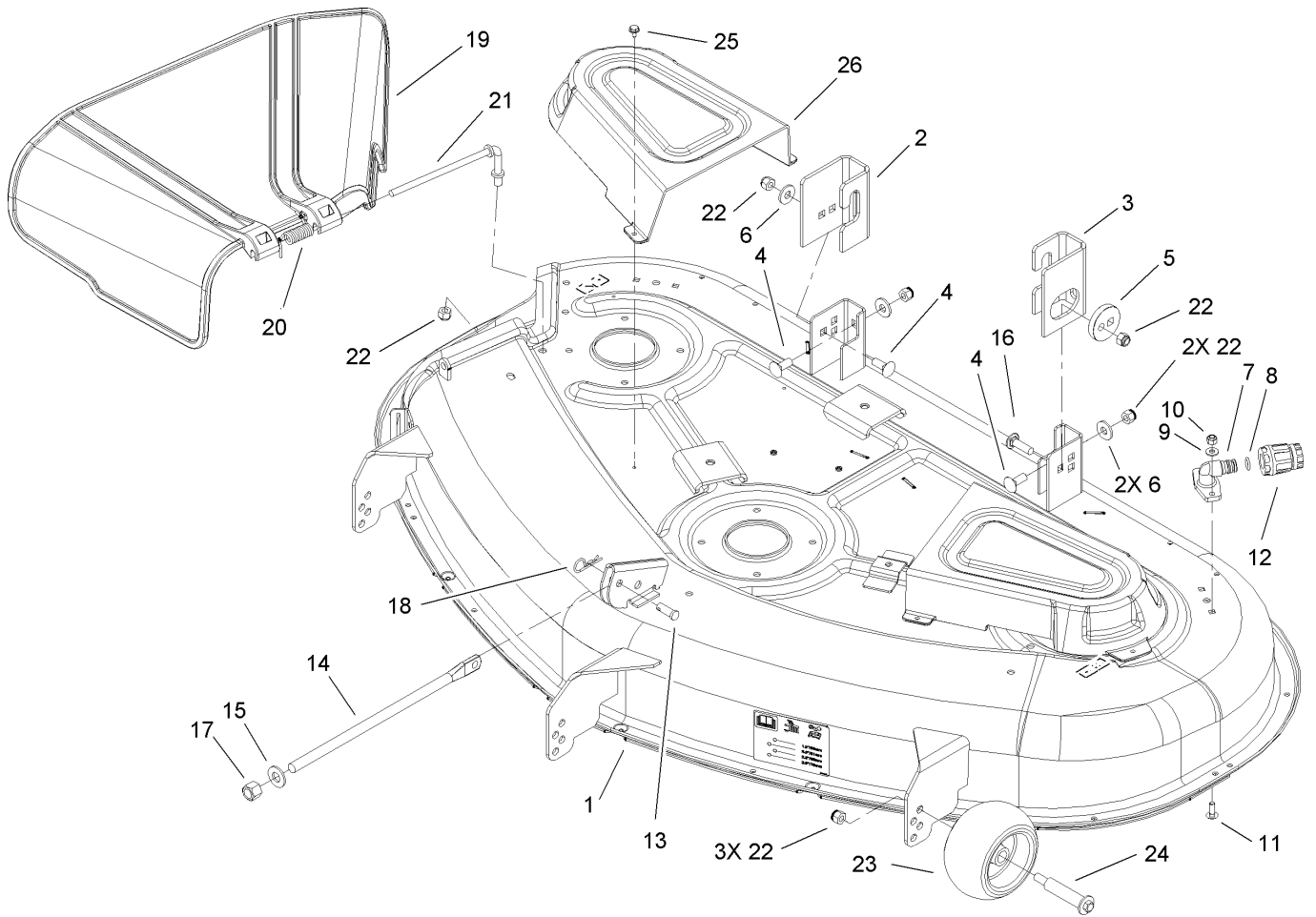

50 Inch Deck and Side Discharge Assembly

Ref	Part No.	Qty.	Description
1	110-6790	1	50 Inch Deck ASM
2	108-7836	1	Bracket-Hanger, Right Rear
3	108-7838	1	Bracket-Hanger, Left Rear
4	3231-2	3	Screw-CARR
5	112-3980	1	Eccentric
6	80-6990	3	Washer-Hardened
7	95-2747	2	Fitting-Washout
8	46-6290	2	O-Ring
9	3256-22	4	Washer-Flat
10	3296-42	4	Nut-Lock, NI
11	3229-1	4	Screw-CARR
12	95-3270	1	Connector-Hose
13	1-808284	1	Pin-Clevis
14	108-7847	1	Rod-Lift
15	87-7270	1	Washer-Thrust
16	3231-28	1	Screw-CARR
17	3296-23	1	Nut-Lock, NI
18	9335054	1	Pin-Hair
19	108-7895	1	Deflector-50 Inch
20	110-6694	1	Spring-Torsion
21	112-3950	1	Rod-Pivot
22	3296-39	8	Nut-Lock, NI
23	1-603299	3	Roller-Scalp, Anti
24	112-3977	3	Bolt-Shoulder

Ref	Part No.	Qty.	Description
25	32104-76	6	Screw
26	108-7890	2	Cover-Belt

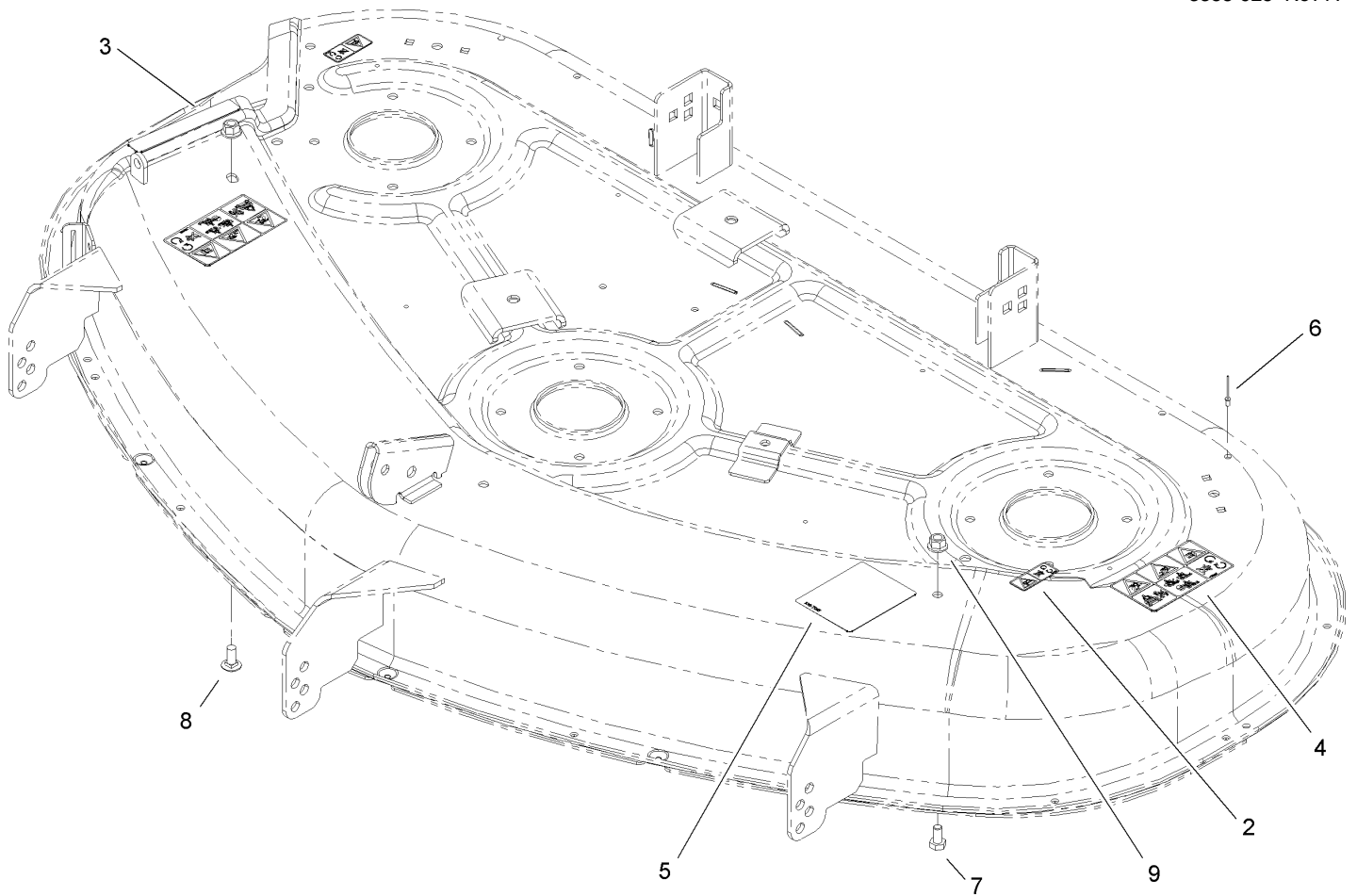

50 Inch Deck Assembly No. 110-6790

Ref	Part No.	Qty.	Description
2	114-1606	2	Decal-Danger, Pulley
3	93-7009	1	Decal-Danger
4	110-6691	2	Decal-Danger
5	105-7015	1	Decal-Routing, Belt
6	3290-282	2	Rivet-Pop
7	322-2	1	Screw-HH
8	3230-23	1	Screw-CARR
9	3296-58	2	Nut-Lock, NI

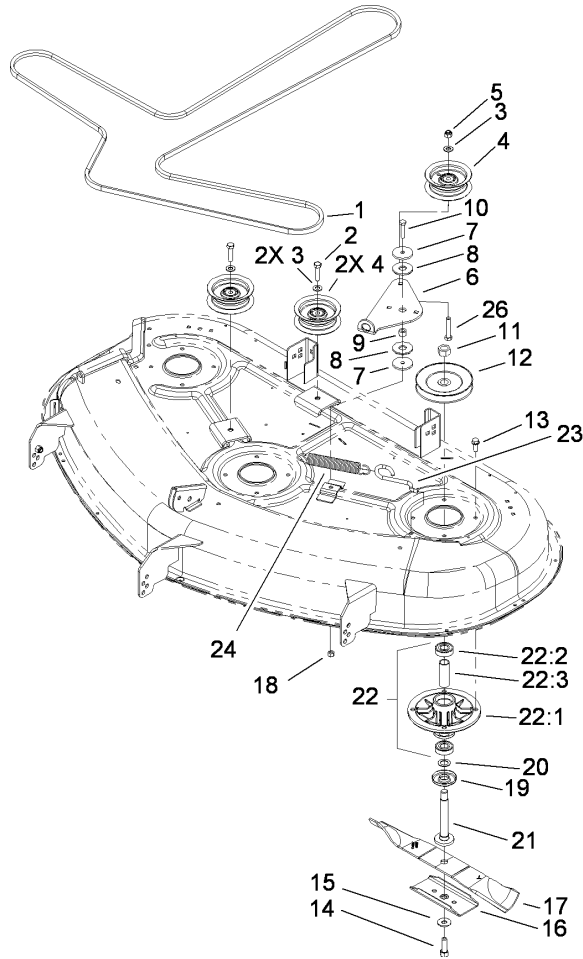

50 Inch Deck Spindle and Belt Drive Assembly

Ref	Part No.	Qty.	Description
1	110-6892	1	V-Belt
2	323-8	2	Screw-HH
3	3256-24	3	Washer-Flat
4	106-2175	3	Pulley-Idler, Flat
5	3296-39	1	Nut-Lock, NI
6	114-8540	1	Arm-Idler
7	115-2455	2	Spacer
8	114-0463	2	Washer-Friction, Composite
9	114-8549	1	Bushing
10	322-7	1	Screw-HH
11	3219-6	3	Nut-Hex
12	110-6865	3	Pulley
13	32144-41	12	Screw-Taptite
14	26-0671	3	Screw-Blade
15	3290-465	3	Washer-Belleville
16	106-2248-03	3	Stiffener-Blade
17	110-6837-03	3	Blade-17.5 Inch, High Lift
18	3296-29	1	Nut-Lock, NI
19	80-4360	3	Shield-Bearing
20	80-4380	3	Spacer
21	110-6866	3	Shaft-Spindle
22		3	Spindle ASM
22:1	88-4510	1	Housing-Spindle
22:2	100-1048	2	Bearing-Ball

Ref	Part No.	Qty.	Description
22:3	62-3661	1	Spacer-Bearing
23	112-3973	1	Hook-Return, Spring
24	1-603414	1	Spring-Extension
26	323-10	1	Screw-HH

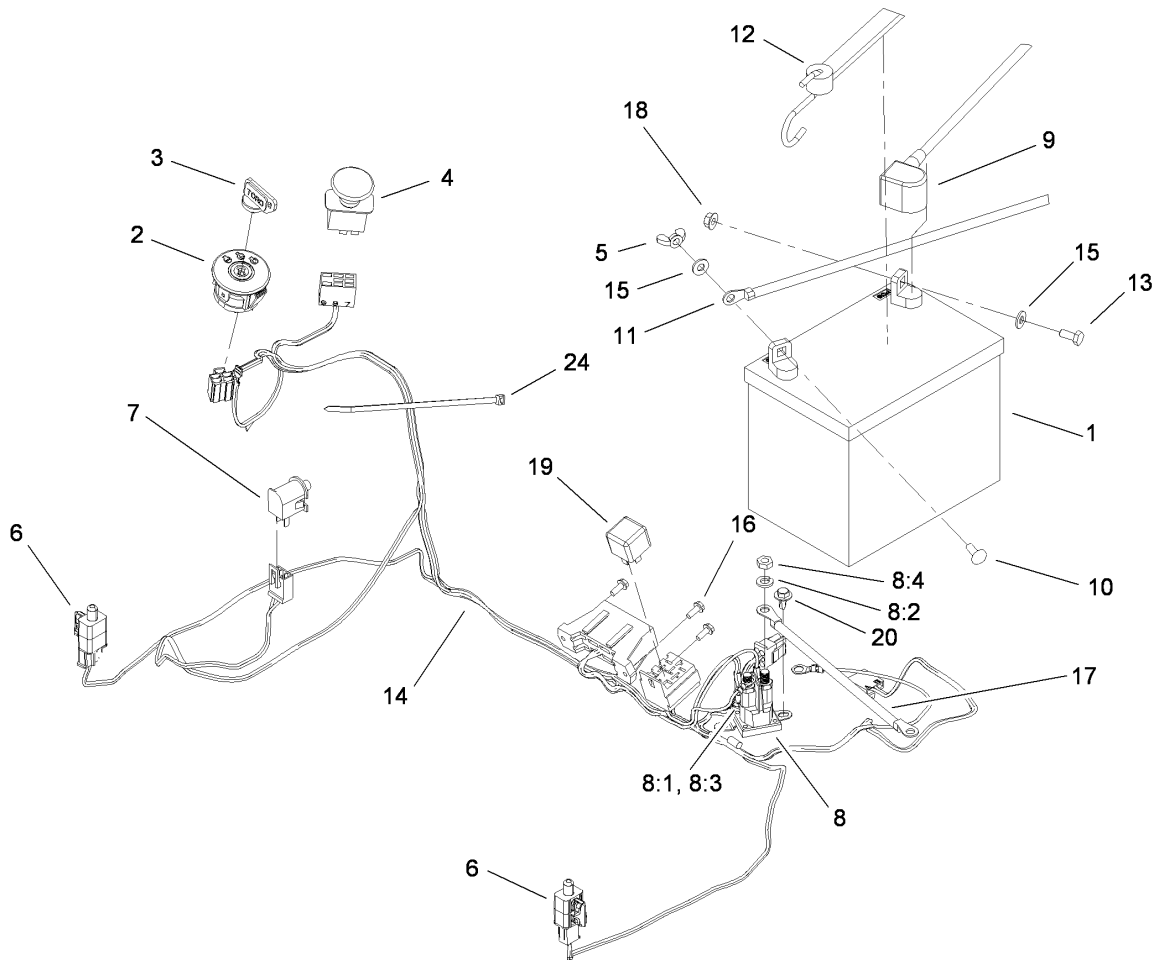

Electrical Assembly

Ref	Part No.	Qty.	Description
1	104-2493	1	Battery
2	110-6764	1	Switch-Ignition
3	63-8360	1	Key-Ignition
4	93-9998	1	Switch-PTO
5	32103-22	1	Nut-Wing
6	110-6765	2	Switch-Single Pole No
7	82-2190	1	Switch-Bail
8	1-513075	1	Switch-Solenoid
8:1	3253-17	2	Washer-Lock
8:2	3253-4	2	Washer-Lock
8:3	3219-14	2	Nut-Hex
8:4	3220-2	2	Nut-Jam
9	110-6794	1	Cable-Battery, Red
10	3229-1	1	Screw-CARR
11	110-6793	1	Cable-Battery, Black
12	104-2466	1	Holddown-Battery
13	321-3	1	Screw-HH
14	114-8533	1	Harness-Wire
15	3256-22	2	Washer-Flat
16	32144-1	3	Screw-Taptite
17	110-6792	1	Cable-Battery, Red
18	32128-33	2	Nut-HF
19	98-7249	1	Relay
20	46-8560	2	Screw-HHF

Ref	Part No.	Qty.	Description
24	614249	1	Strap-Tie

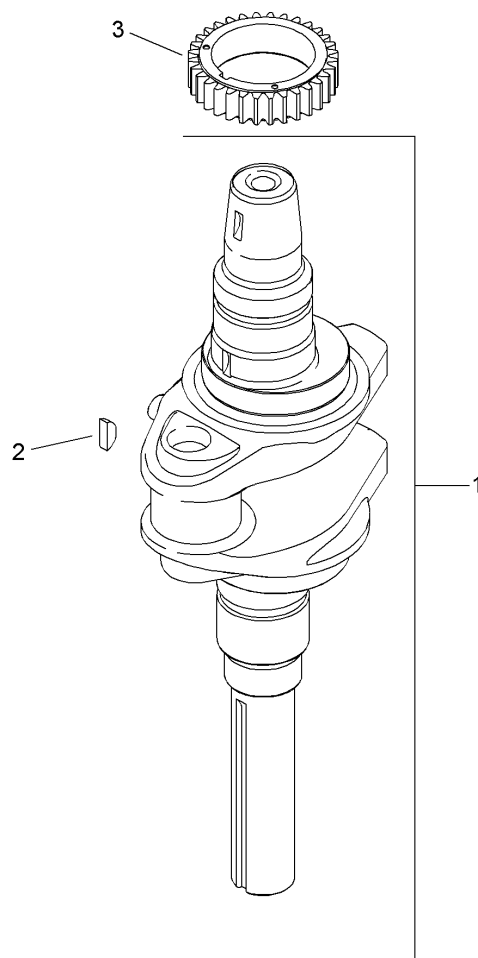

Crankshaft Assembly Kohler SV610-0020

Ref	Part No.	Qty.	Description
①	20 014 20-S	1	Crankshaft
②	X-42-15-S	1	Key (3/16 X 5/8)
③	20 043 12-S	1	Gear-Crankshaft

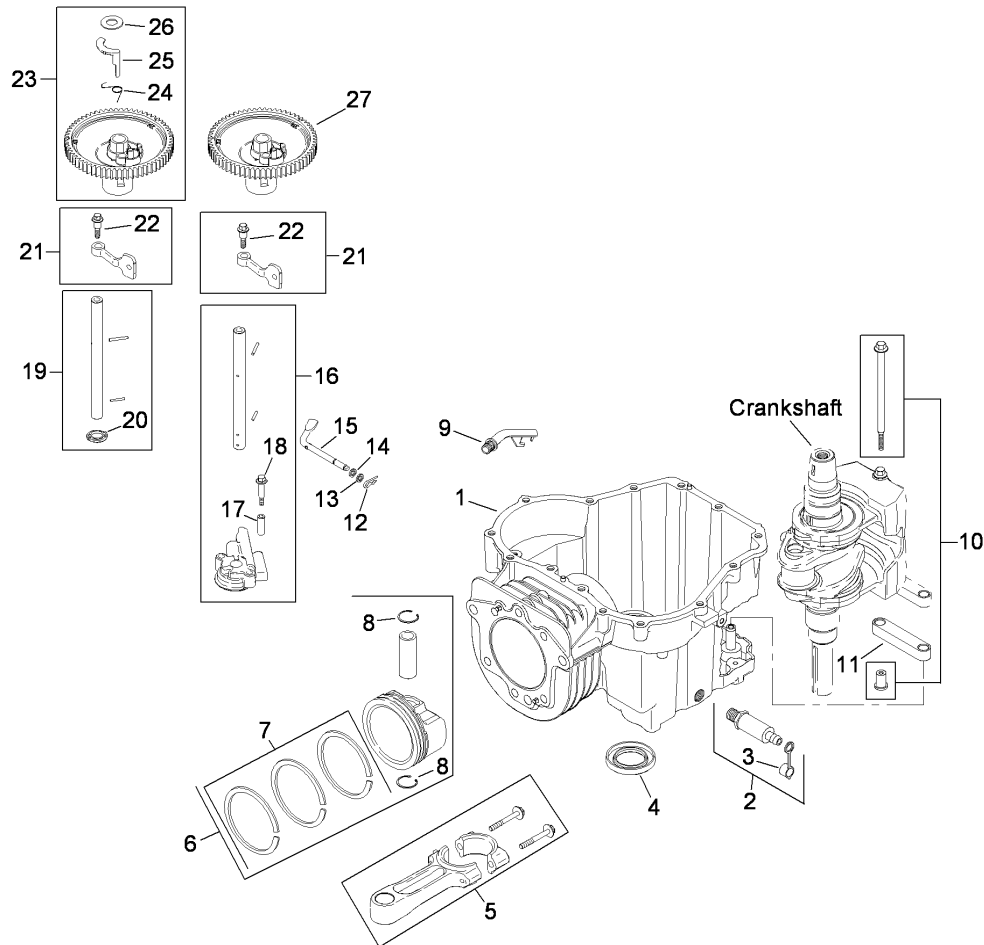

Crankcase Assembly Kohler SV610-0020

Ref	Part No.	Qty.	Description
❶	20 522 02	1	Crankcase (Sv530/540 Short Block)
❷	25 755 14-S	1	Oil Drain Valve ASM (Includes 3)
❸	25 173 14-S	1	Cap-Valve, Oil Drain
❹	20 032 01-S	1	Seal-Oil
❺	20 067 04-S	1	Connecting Rod ASM
❻	20 874 01-S	1	Piston And Ring Set (94 Mm) (Includes 7, 8)
❼	20 108 01-S	1	Ring Set (94 Mm)
❽	20 018 04-S	2	Retainer-Pin, Piston
❾	20 123 02-S	1	Tube-Back, Drain
❿	20 380 16-S	1	Locating Pin ASM
⓫	20 186 02-S	1	Linkage-Weight, Balance
⓬	12 154 05-S	1	Clip-Pin, Hitch
⓭	M-631015-S	1	Washer-Flat (6Mm)
⓮	X-25-102-S	1	Washer-Flat (1/4)
⓯	20 144 02-S	1	Shaft-Cross, Governor
⓰	20 393 02-S	1	Oil Pump ASM (Includes 17, 18)
⓱	20 112 02-S	2	Spacer-Screw, Oil Pump
⓲	20 086 13-S	2	Screw-Pump, Oil
⓳	20 144 11-S	1	Camshaft Center ASM (Exhaust) (Includes 20)
⓴	20 468 08-S	1	Washer-Thrust
⓵	20 090 01-S	2	Cam Lever ASM (Includes 22)
⓶	20 086 06-S	2	Bolt-Shoulder (M6X1X26)

Ref	Part No.	Qty.	Description
⓷	20 010 06-S	1	Cam Gear ASM (Exhaust) (Includes 24-26)
⓸	20 089 06-S	1	Spring-A C R
⓹	20 044 16-S	1	Weight-A C R
⓺	20 468 03-S	1	Washer-Thrust, A C R
⓻	20 010 05-S	1	Cam Gear ASM (Intake)

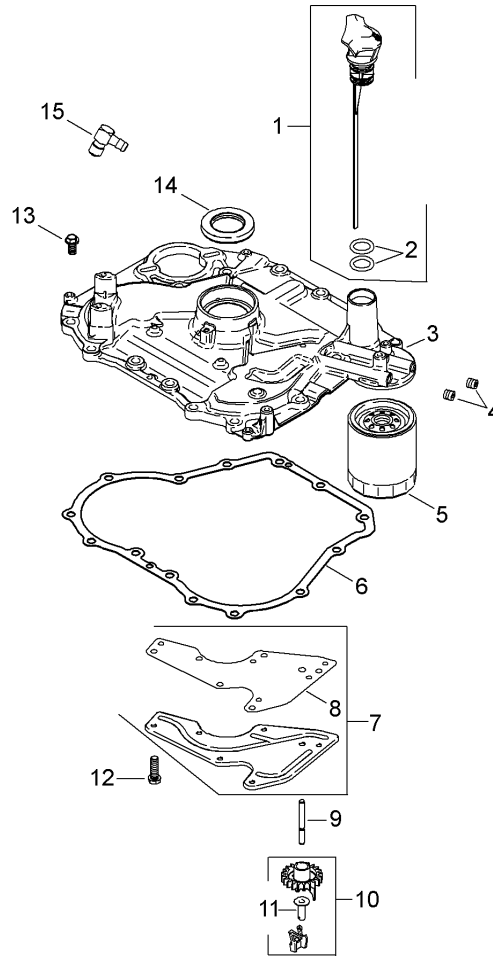

Oil Pan and Lubrication Assembly Kohler SV610-0020

Ref	Part No.	Qty.	Description				
❶	20 040 02-S	1	Dipstick Blade Kit (Yellow) (Includes 2)				
❷	20 153 01-S	2	O Ring-Dipstick				
❸	20 009 10-S	1	Closure Plate ASM (Includes 6, 15)				
❹	25 139 60-S	2	Plug-Hex, Countersunk (.125)				
❺	12 050 01-S	1	Filter-Oil				
❻	20 041 01-S	1	Gasket-Plate, Closure				
❼	20 096 02-S	1	Oil Passage Cover Kit (Includes 8)				
❽	20 041 02-S	1	Gasket-Passage, Oil				
❾	20 144 03-S	1	Shaft-Gear, Governor				
❿	20 310 03-S	1	Governor Gear ASM (Includes 11)				
⓫	12 380 01-S	1	Pin-Regulating, Governor				
⓬	M-545013-S	6	Screw-Flange, Hex (M5X0.8X13)				
⓭	M-851030-S	14	Screw-Flange, Hex (M8X1.25X30)				
⓮	20 032 01-S	1	Seal-Oil				
⓯	25 155 02-S	1	Connector-Hose, 90 DEG				

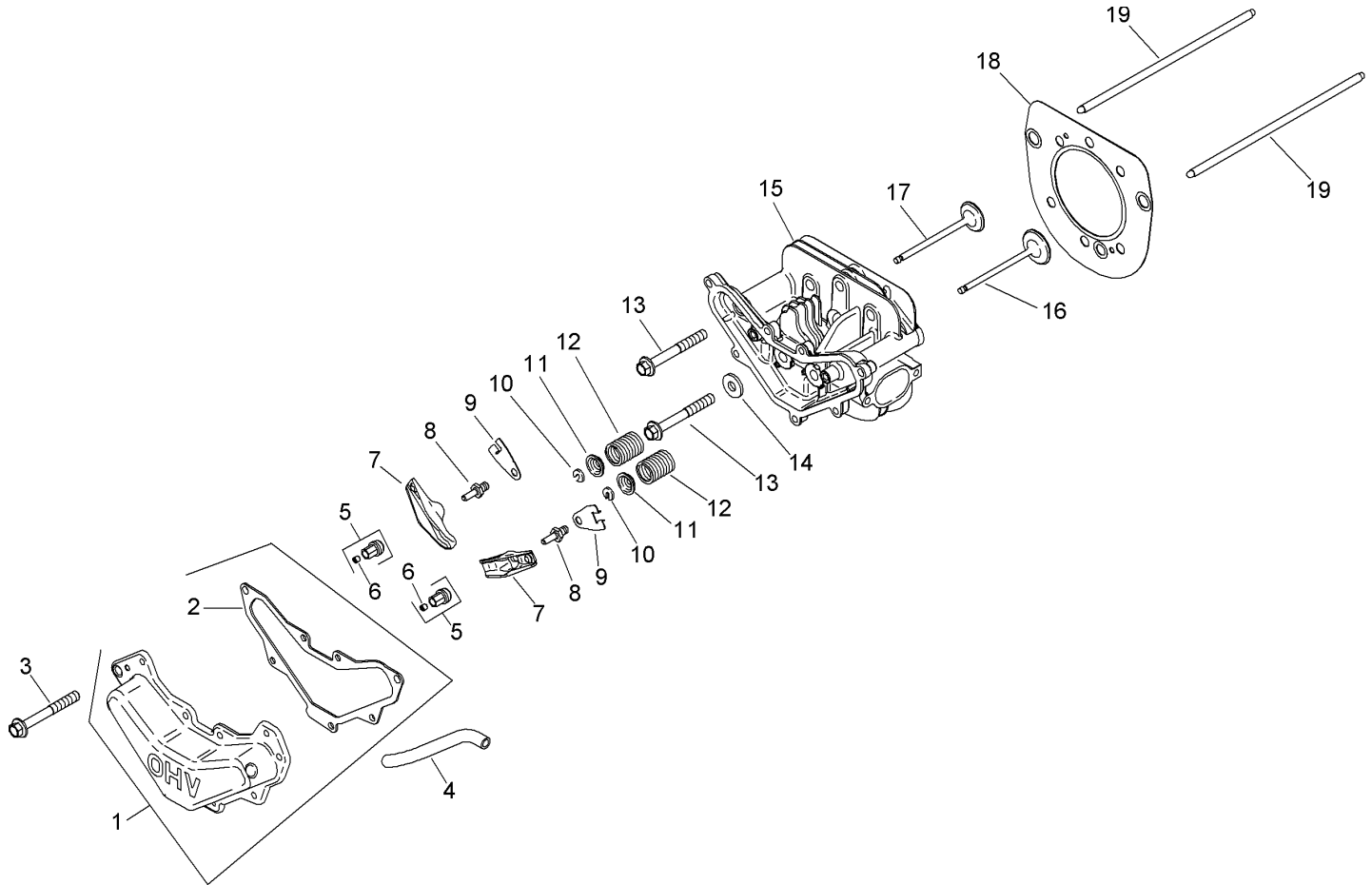

Head, Valve and Breather Assembly Kohler SV610-0020

Ref	Part No.	Qty.	Description
❶	20 096 07-S	1	Valve Cover Kit (Includes 2)
❷	20 041 13-S	1	Gasket-Cover, Valve
❸	M-645020-S	7	Screw-Flange, Hex (M6X1.0X20)
❹	20 326 01-S	1	Hose-Breather
❺	20 599 02-S	2	Pivot-Arm, Rocker (Includes 6)
❻	20 086 04-S	2	Screw-Set
❼	20 186 01-S	2	Arm-Rocker
❽	20 086 03-S	2	Stud-Rocker
❾	20 146 03-S	2	Plate-Guide, Push Rod
❿	20 062 01-S	2	Lock-Retainer
⓫	20 173 01-S	2	Cap-Spring, Valve
⓬	20 089 03-S	2	Spring-Valve
⓭	20 086 02-S	6	Screw-Flange, Hex (M10X1.5X37)
⓮	12 468 05-S	1	Washer-Flat (1/2)
⓯	20 318 05-S	1	Cylinder Head ASM
⓰	20 016 01-S	1	Valve-Exhaust
⓱	20 017 01-S	1	Valve-Intake
⓲	20 841 01-S	1	Cylinder Head Gasket Kit (Includes 2, 13, 14)
⓳	20 411 04-S	2	Rod-Push

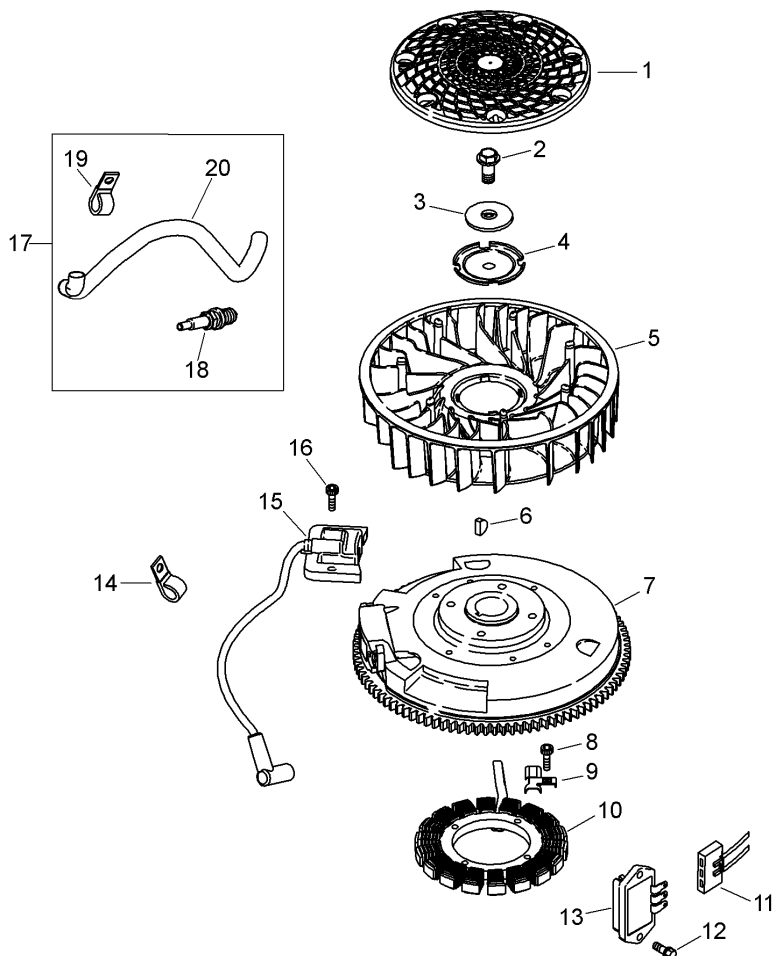

Ignition and Electrical Assembly Kohler SV610-0020

Ref	Part No.	Qty.	Description
1	20 162 02-S	1	Screen-Grass
2	12 086 14-S	1	Screw-Hex, Flange (M10X1.5X45)
3	12 468 03-S	1	Washer-Flat (.38)
4	20 146 04-S	1	Plate-Mounting, Fan
5	20 157 01-S	1	Fan
6	X-42-15-S	1	Key (.19 X .62)
7	20 025 05-S	1	Flywheel
8	20 086 17-S	2	Screw-Socket, Hex (M5X0.8X25)
9	20 154 03-S	1	Clip-Wire, Stator
10	237878-S	1	Stator Kit (15 Amp)
11	236602-S	1	Connector (3 Contact)
12	M-545020-S	2	Screw-HHFTF (M5X0.8X20)
13	41 403 09-S	1	Rectifier-Regulator
14	231285-S	2	Clip-Cable
15	20 584 01-S	1	Module-Ignition
16	M-561025-S	2	Screw-Socket, Hex (M5X0.8X25)
17	20 707 01-S	1	R F I Suppression Kit (Includes 18-20)
18	25 132 14-S	1	Spark Plug (R F I)
19	25 154 08-S	1	Clip-Cable
20	20 123 01-S	1	Tube (R F I)
1 5	20 176 01-S	1	Harness-Wiring (Six Pin)

--	--	--	--

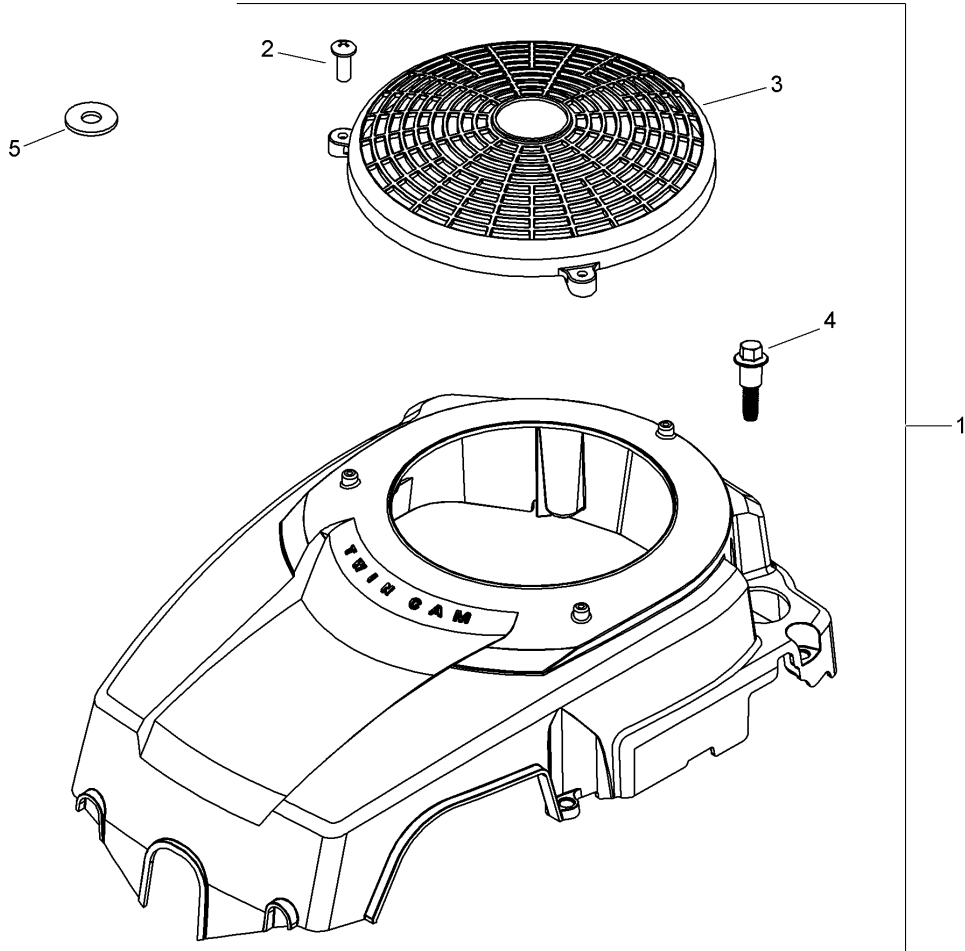

Blower Housing Assembly Kohler SV610-0020

Ref	Part No.	Qty.	Description				
1	20 755 11-S	1	Blower Housing And Guard ASM (Includes 2-4, 20 113 29-S, 41 037 10-S)				
2	24 086 41-S	3	Screw-Phi HD (11-16X1/2)				
3	20 314 06-S	1	Guard-Fixed				
4	20 086 06-S	4	Bolt-Shoulder (M6X1X26)				
5	24 468 10-S	3	Washer-Plain (1/4)				
1	20 113 29-S	1	Label-Round, Kohler				
1	41 037 10-S	1	Nameplate-Service				

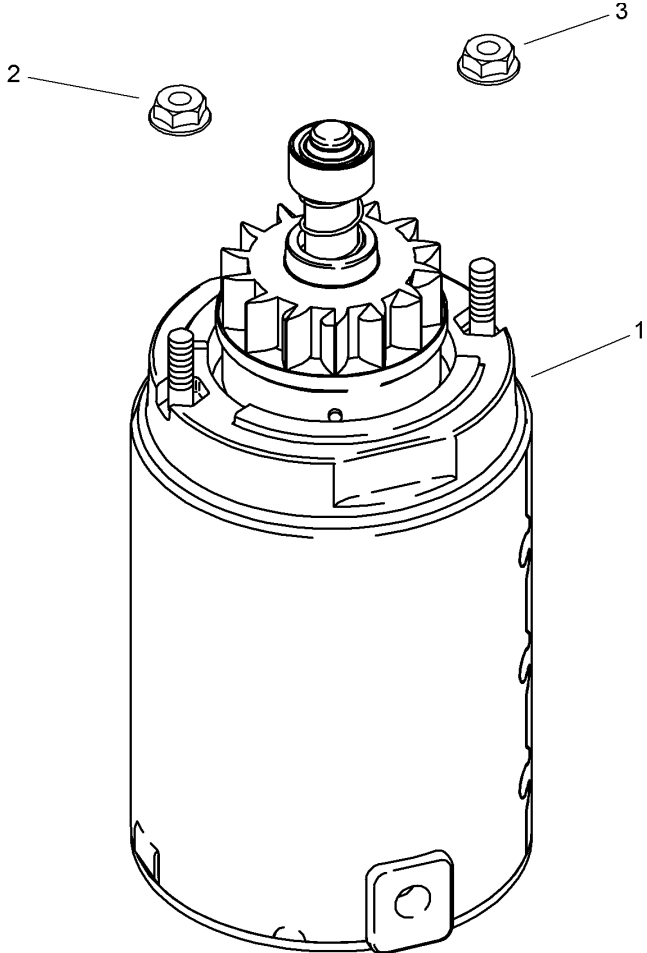

Starter Assembly Kohler SV610-0020

Ref	Part No.	Qty.	Description
❶	20 098 05-S	1	Starter ASM
❷	25 100 31-S	2	Nut-Flange, Hex Serrated (10-24)
❸	12 100 07-S	1	Nut-Flange, Hex (1/4-20)

--	--	--	--

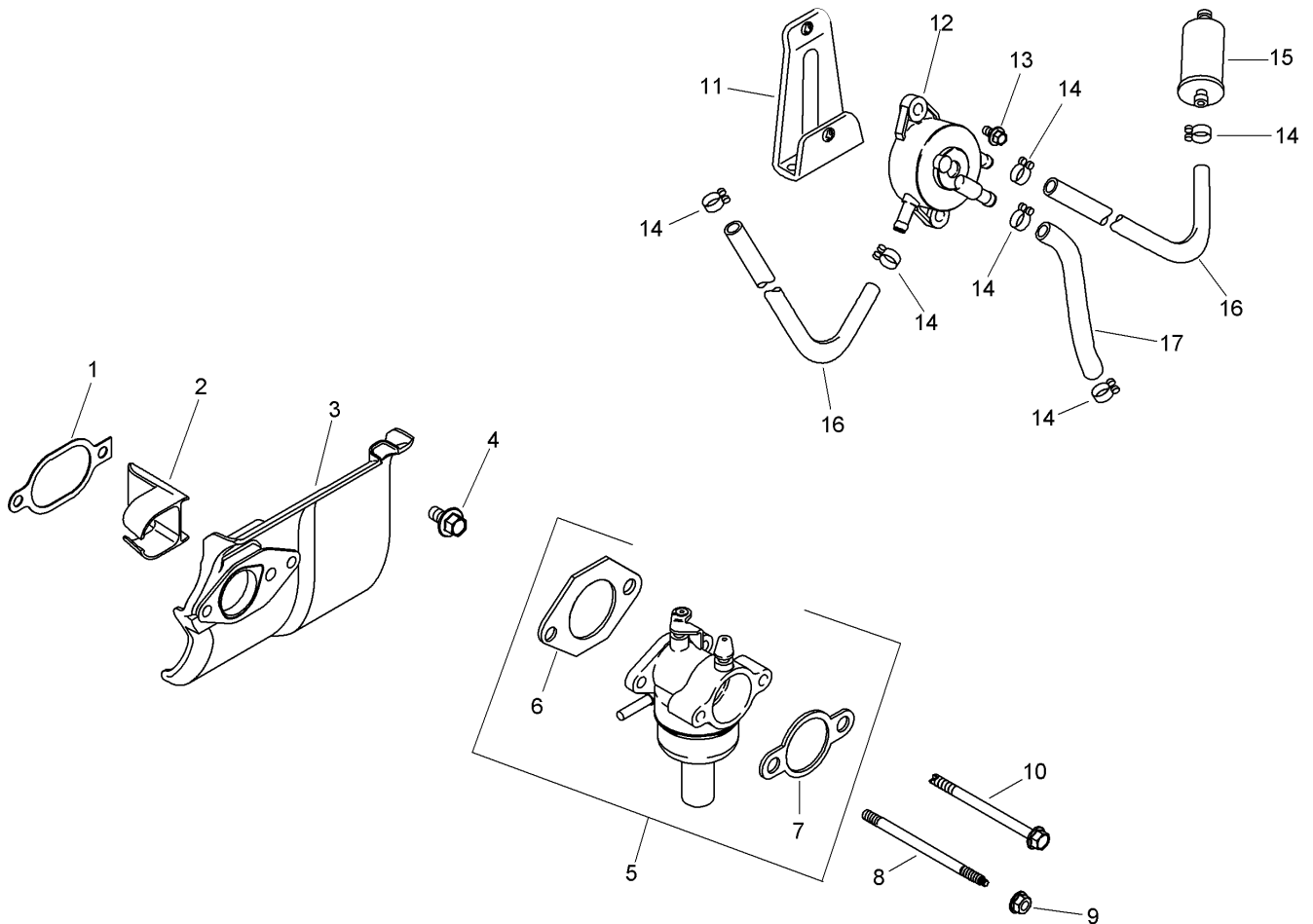

Fuel System Assembly Kohler SV610-0020

Ref	Part No.	Qty.	Description
❶	20 041 07-S	1	Gasket-Deflector, Heat
❷	20 332 01-S	1	Insert-Port, Intake
❸	20 265 03-S	1	Deflector-Heat
❹	M-651020-S	1	Screw-Flange, Hex (M6X1.0X20)
❺	20 853 14-S	1	Carburetor ASM W/Gaskets (Includes 6, 7)
❻	12 041 01-S	1	Gasket-Carburetor
❼	12 041 02-S	1	Gasket-Base, Air Cleaner
❽	20 072 05-S	2	Stud-Mounting, Carburetor (M6X1.0X100)
❾	M-641060-S	2	Nut-Hex, Flange (M6X1.0)
❿	M-545010-S	2	Screw-HHFTF (M5X0.8X10)
⓫	20 126 02-S	1	Bracket-Mounting, Fuel Pump
⓬	24 393 16-S	1	Pump-Pulse, Fuel
⓭	M-645016-S	2	Screw-HHFTF (M6X1.0X16)
⓮	25 237 14-S	6	Clamp-Hose
⓯	25 050 22-S	1	Filter-Fuel
⓰	25 111 34-S	2	Line-Fuel (24 Inch, Cut to needed Length)
⓱	52 353 20-S	1	Line-Fuel (10 Inch)
⓲	25 454 05-S	1	Tie
⓳	X-22-11-S	1	Washer-Lock, Internal Tooth (1/4)
⓴	25 431 12-S	1	Sleeve, Fuel Line
⓵	12 755 110-S	1	Choke Shaft Kit
⓶	12 757 02-S	1	Float Repair Kit

Ref	Part No.	Qty.	Description
⓷	12 757 03-S	1	Carburetor Repair Kit
⓸	12 757 33-S	1	Solenoid Repair Kit
⓹	12 757 37-S	1	Bowl Replacement Repair Kit
⓺	20 755 06-S	1	High Altitude Kit (5, 000 Ft)
⓻	20 755 07-S	1	High Altitude Kit (10, 000 Ft)

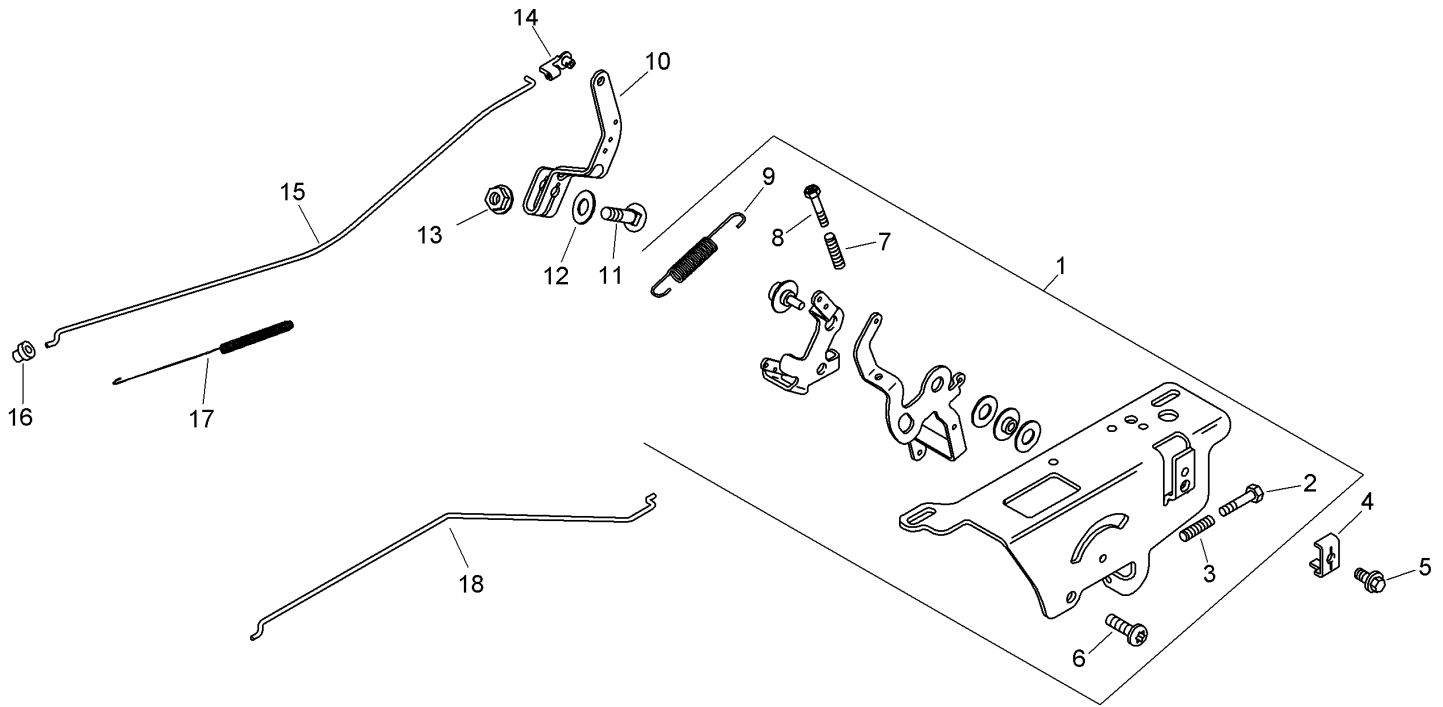

Engine Control Assembly Kohler SV610-0020

Ref	Part No.	Qty.	Description
❶	20 536 05-S	1	Speed Control ASM (Includes 2, 3, 6-9)
❷	20 086 10-S	1	Screw-Thread Forming (M4X0.7X25)
❸	12 089 11-S	1	Spring-Control, Speed (Short)
❹	12 237 01-S	1	Clamp-Cable
❺	M-545016-S	1	Screw-HHFTF (M5X0.8X16)
❻	M-664020-S	2	Screw-Socket, 6 Lobed (Thread Forming, M6X1.0X20)
❼	12 089 11-S	2	Spring-Control, Speed (Short)
❽	20 086 10-S	2	Screw-Thread Forming (M4X0.7X25)
❾	20 089 11-S	1	Spring-Governor
❿	20 090 02-S	1	Lever-Governor
⓫	52 211 04-S	1	Bolt-Square Neck, Round Head (1/4-20X1)
⓬	X-22-11-S	1	Washer-Lock, Internal Tooth (1/4)
⓭	12 100 07-S	1	Nut-Flange, Hex (1/4-20)
⓮	25 158 11-S	1	Bushing-Linkage, Throttle
⓯	20 079 04-S	1	Linkage-Throttle
⓰	25 158 08-S	1	Bushing-Retaining, Linkage
⓱	20 089 10-S	1	Spring-Linkage
⓲	20 079 05-S	1	Linkage-Choke (Single Wire)

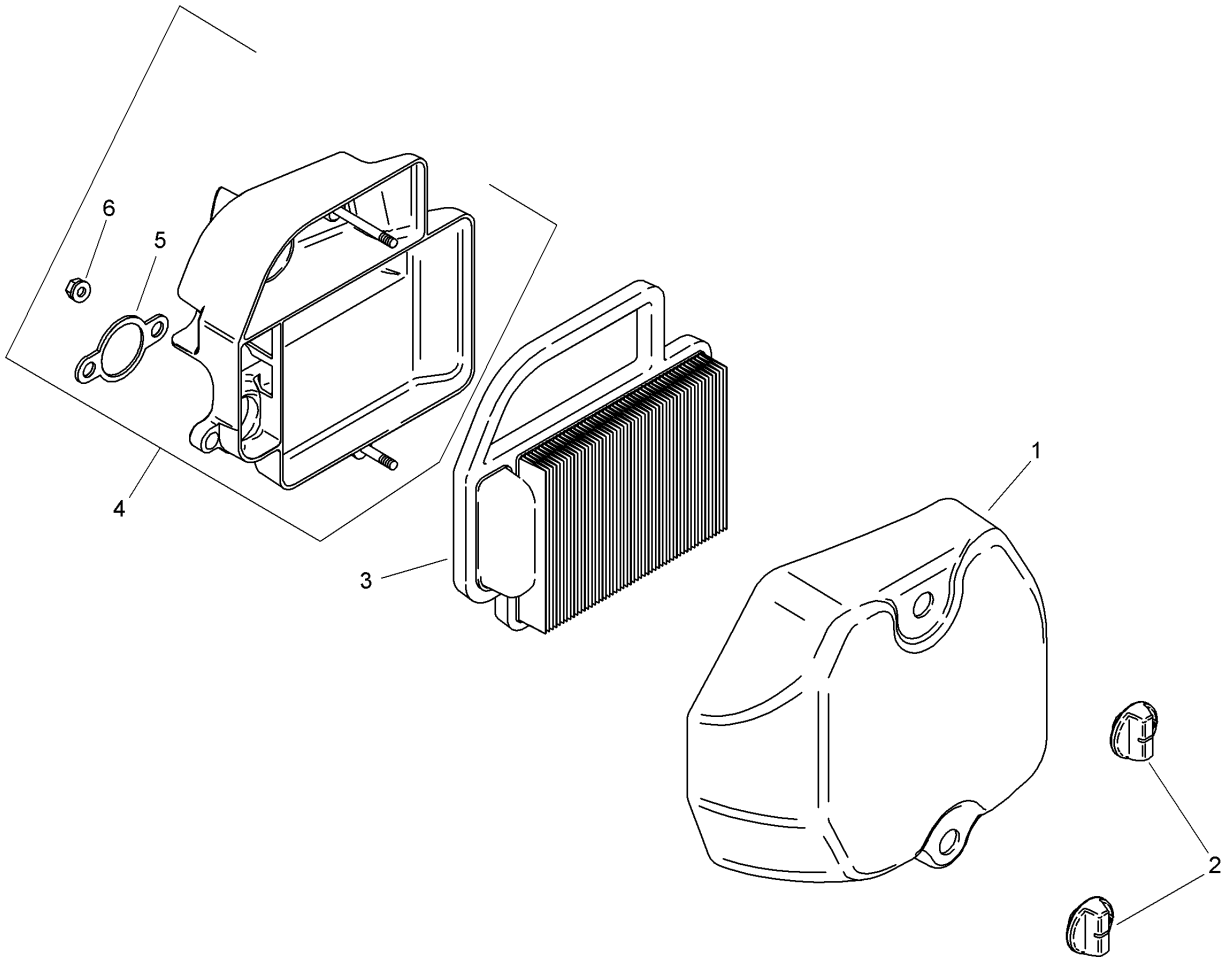

Air Intake and Filtration Assembly Kohler SV610-0020

Ref	Part No.	Qty.	Description
❶	20 096 04-S	1	Cover-Cleaner, Air
❷	25 341 04-S	2	Knob-Cover
❸	20 083 02-S	1	Element-Cleaner, Air
❹	20 094 01-S	1	Air Cleaner Base Kit (Includes 5, 6)
❺	12 041 02-S	1	Gasket-Base, Air Cleaner
❻	M-641060-S	1	Nut-Hex, Flange (M6X1.0)

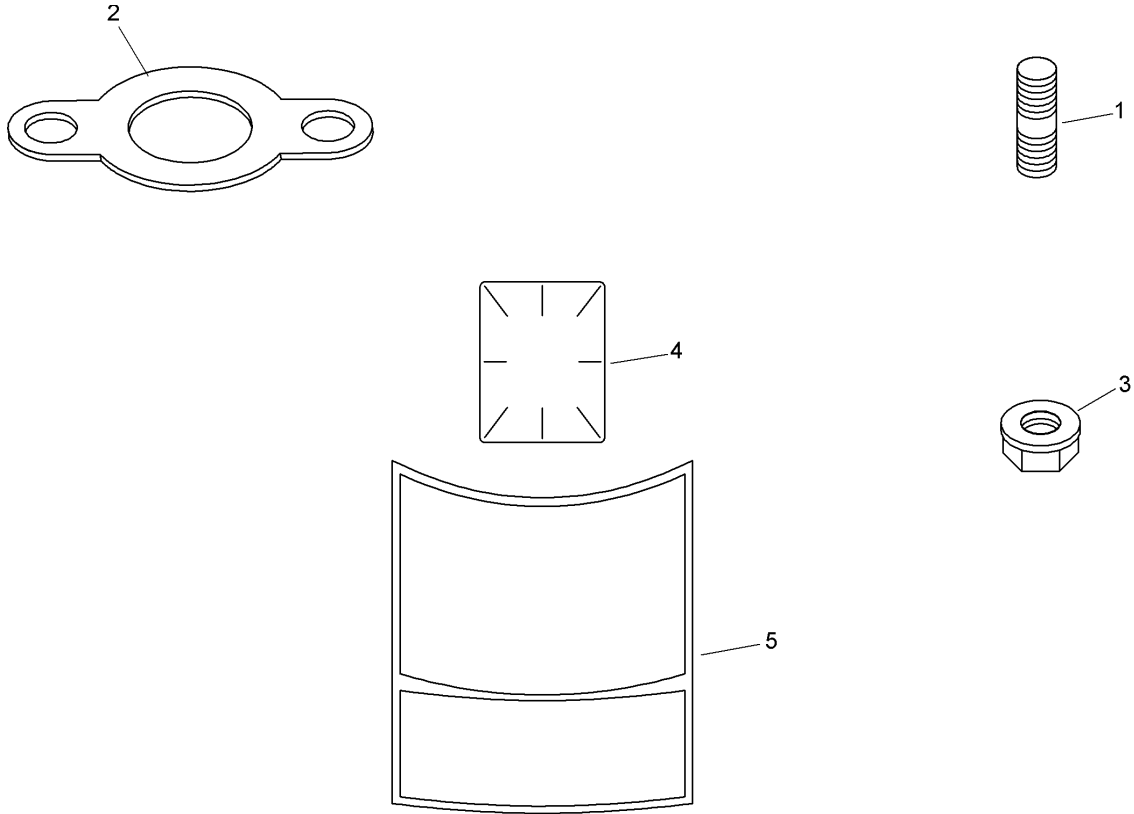

Artwork is representative
 Actual labels may differ depending on model and specification number

Exhaust Stud, Gasket and Decal Assembly Kohler SV610-0020

Ref	Part No.	Qty.	Description
❶	25 072 04-S	2	Stud (M8X1.25X33)
❷	20 041 12-S	1	Gasket-Exhaust
❸	M-841080-S	2	Nut-Hex, Flange (M8X1.25)
❹	25 113 39-S	1	Decal-Laminate, Clear
❺	20 113 13-S	1	Decal (19 H P)
❶❷	20 522 02	1	Crankcase (Sv530/540 Short Block)
❶❸	20 755 05-S	1	Gasket Set

Attachments and Accessories

For 74370 - TimeCutter Z5000 Riding Mower

Product Name	Model/Part
Armrest Kit	108-6163
Hour Meter Kit	112-9763
Deck Ring Kit	114-1608
Striping Kit	114-8545
Armrest Kit	79212
Replacement Blade Kit	79221
50 Inch Recycler Kit	79312
Foot Assist Cutting Unit Lift Kit	79313
Engine Cover Kit	79314
Floor Mat Kit	79315
Storage Cover	79317
Rear Hitch Kit	79318
Sunshade	79319
42 Inch and 50 Inch Twin Bagger	79324

