



Count on it.

Operator's Manual

Sand/Infield Pro[®] 3040 and 5040

Model No. 08703—Serial No. 270000401 and Up

Model No. 08705—Serial No. 270000401 and Up

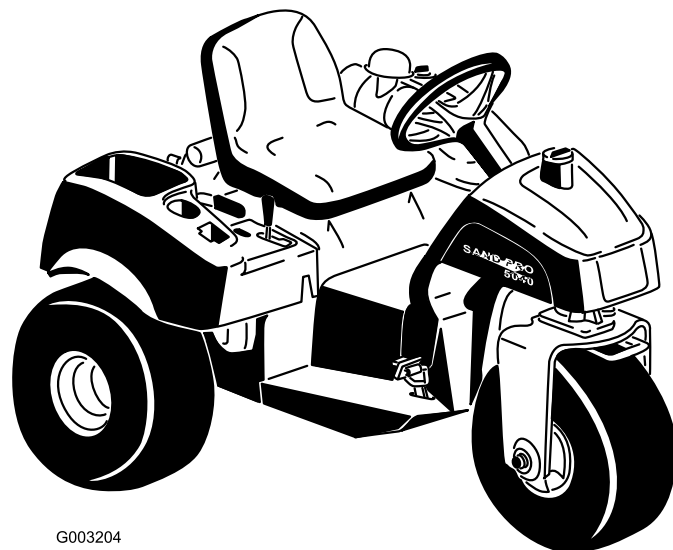

G003204

Warning

CALIFORNIA Proposition 65 Warning

The engine exhaust from this product contains chemicals known to the State of California to cause cancer, birth defects, or other reproductive harm.

Important: This engine is not equipped with a spark arrester muffler. It is a violation of California Public Resource Code Section 4442 to use or operate the engine on any forest-covered, brush-covered, or grass-covered land. Other states or federal areas may have similar laws.

This spark ignition system complies with Canadian ICES-002.

The enclosed *Engine Owner's Manual* is supplied for information regarding the US Environmental Protection Agency (EPA) and the California Emission Control Regulation of emission systems, maintenance, and warranty. Replacements may be ordered through the engine manufacturer.

Introduction

Read this information carefully to learn how to operate and maintain your product properly and to avoid injury and product damage. You are responsible for operating the product properly and safely.

You may contact Toro directly at www.Toro.com for product and accessory information, help finding a dealer, or to register your product.

Whenever you need service, genuine Toro parts, or additional information, contact an Authorized Service Dealer or Toro Customer Service and have the model and serial numbers of your product ready. These numbers are stamped into a plate located on the left frame rail. Write the numbers in the space provided.

Model No. _____
Serial No. _____

This manual identifies potential hazards and has safety messages identified by the safety alert symbol (Figure 1), which signals a hazard that may cause serious injury or death if you do not follow the recommended precautions.



Figure 1

1. Safety alert symbol

This manual uses 2 other words to highlight information. **Important** calls attention to special mechanical information and **Note** emphasizes general information worthy of special attention.

Contents

Introduction.....	2	Adjusting the Traction Interlock Switch	30
Safety	4	Adjusting the Transport Speed.....	31
Safe Operating Practices	4	Controls System Maintenance.....	31
Sound Pressure Level	6	Adjusting the Lift Lever	31
Sound Power Level.....	6	Adjusting the Engine Controls	32
Vibration Level.....	6	Hydraulic System Maintenance	33
Safety and Instructional Decals	6	Changing the Hydraulic System Oil and	
Setup.....	9	Filter	33
1 Installing the Steering Wheel	9	Checking the Hydraulic Lines and Hoses	34
2 Removing the Battery	9	Charging the Hydraulic System	34
3 Activating and Charging the Battery.....	10	Cleaning.....	36
4 Installing the Battery.....	11	Inspecting and Cleaning the Machine	36
5 Installing the Infield Pro® Decal		Storage.....	36
(Optional)	12	Traction Unit.....	36
6 Reading the Manuals and Viewing the		Engine	36
Video	12	Schematics	37
7 Installing Front Weights	13		
Product Overview	14		
Controls	14		
Specifications	16		
Attachments/Accessories.....	16		
Operation.....	17		
Checking the Engine Oil Level.....	17		
Filling the Fuel Tank.....	17		
Checking the Hydraulic Fluid Level.....	18		
Checking the Tire Pressure	19		
Torquing the Wheel Lug Nuts	20		
Starting and Stopping the Engine	20		
Checking the Interlock System.....	20		
Towing the Machine	21		
Break-in Period	21		
Operating Characteristics	21		
Maintenance.....	22		
Recommended Maintenance Schedule(s)	22		
Daily Maintenance Checklist.....	23		
Premaintenance Procedures.....	24		
Jacking the Machine.....	24		
Lubrication.....	24		
Greasing the Machine	25		
Engine Maintenance.....	25		
Changing the Engine Oil and Filter	25		
Servicing the Air Cleaner	25		
Replacing the Spark Plugs	26		
Fuel System Maintenance	27		
Replacing the Fuel Filter	27		
Electrical System Maintenance.....	28		
Jump Starting the Machine.....	28		
Replacing Fuses.....	28		
Caring for the Battery	29		
Drive System Maintenance	30		
Adjusting the Traction Drive for Neutral	30		

Safety

This machine meets or exceeds CEN standard EN 836:1997, ISO standard 5395:1990 (when appropriate decals are applied), and ANSI B71.4-2004 specifications in effect at the time of production, when weights are installed in accordance with the chart found in the Setup Section.

Improper use or maintenance by the operator or owner can result in injury. To reduce the potential for injury, comply with these safety instructions and always pay attention to the safety alert symbol , which means **Caution, Warning, or Danger**—“personal safety instruction.” **Failure to comply with the instruction may result in personal injury or death.**

Safe Operating Practices

The following instructions are from the CEN standard EN 836:1997, ISO standard 5395:1990, and ANSI B71.4-2004.

Training

- Read the operator’s manual and other training material carefully. Be familiar with the controls, safety signs, and the proper use of the equipment.
- If the operator or mechanic can not read the language of is the owner’s responsibility to explain this material to them.
- Never allow children or people unfamiliar with these instructions to use or service the machine. Local regulations may restrict the age of the operator.
- Never operate while people, especially children, or pets are nearby.
- Keep in mind that the operator or user is responsible for accidents or hazards occurring to other people or their property.
- Do not carry passengers.
- All drivers and mechanics should seek and obtain professional and practical instruction. The owner is responsible for training the users. Such instruction should emphasize:
 - the need for care and concentration when working with ride-on machines;
 - control of a ride-on machine sliding on a slope will not be regained by the application of the brake. The main reasons for loss of control are:
 - ◇ insufficient wheel grip;
 - ◇ being driven too fast;
 - ◇ inadequate braking;

- ◇ the type of machine is unsuitable for its task;
- ◇ lack of awareness of the effect of ground conditions, especially slopes;
- ◇ incorrect hitching and load distribution.

- The owner/user can prevent and is responsible for accidents or injuries occurring to himself or herself, other people, or property.

Preparation

- While operating, always wear substantial footwear, long trousers, hard hat, safety glasses, and ear protection. Long hair, loose clothing, or jewelry may get tangled in moving parts. Do not operate the equipment when barefoot or wearing open sandals.
- **Warning**—Fuel is highly flammable. Take the following precautions:
 - Store fuel in containers specifically designed for this purpose.
 - Refuel outdoors only and do not smoke while refueling.
 - Add fuel before starting the engine. Never remove the cap of the fuel tank or add fuel while the engine is running or when the engine is hot.
 - If fuel is spilled, do not attempt to start the engine but move the machine away from the area of spillage and avoid creating any source of ignition until fuel vapors have dissipated.
 - Replace all fuel tanks and container caps securely.
- Replace faulty mufflers.
- Evaluate the terrain to determine what accessories and attachments are needed to properly and safely perform the job. Only use accessories and attachments approved by the manufacturer.
- Check that operator’s presence controls, safety switches and shields are attached and functioning properly. Do not operate unless they are functioning properly.

Operation



Engine exhaust contains carbon monoxide, which is an odorless, deadly poison that can kill you.

Do not run engine indoors or in an enclosed area.

- Do not operate the engine in a confined space where dangerous carbon monoxide fumes can collect.
- Operate only in daylight or in good artificial light.
- Before attempting to start the engine, disengage all attachments, shift into neutral, and engage the parking brake.
- Do not put hands or feet near or under rotating parts.
- Using the machine demands attention. To prevent tipping or loss of control:
 - Watch for holes or other hidden hazards.
 - Use caution when operating the machine on a steep slope. Reduce your speed when making sharp turns or when turning on hillsides.
 - Avoid sudden stops and starts. Do not go from reverse to full forward without first coming to a complete stop.
 - Before backing up, look to the rear and ensure that no one is behind the machine.
 - Watch out for traffic when near or crossing roads. Always yield the right of way.
- If the optional Hitch Tow Bar, Part No. 110-1375, is installed on the machine, refer to the attachment *Operator's Manual* for maximum hitch load.
- Stay alert for holes in the terrain and other hidden hazards.
- Use care when pulling loads or using heavy equipment.
 - Use only approved hitch points.
 - Limit loads to those you can safely control.
 - Do not turn sharply. Use care when reversing.
- Never operate the machine with damaged guards, shields, or without safety protective devices in place. Be sure all interlocks are attached, adjusted properly, and functioning properly.
- Do not change the engine governor settings or overspeed the engine. Operating the engine at excessive speed may increase the hazard of personal injury.
- Before leaving the operator's position:
 - stop on level ground;
 - release the traction pedal and lower the attachments;
 - set the parking brake;
 - stop the engine and remove the key.
- Disengage drive to attachments when transporting or not in use.
- Stop the engine and disengage drive to attachment
 - before refuelling;
 - before checking, cleaning or working on the machine;
 - after striking a foreign object or if an abnormal vibration occurs. Inspect the machine for damage and make repairs before restarting and operating the equipment.
- Reduce the throttle setting during engine run-out and, if the engine is provided with a shut-off valve, turn the fuel off at the conclusion of operation.
- Look behind and down before backing up to be sure of a clear path.
- Slow down and use caution when making turns and crossing roads and sidewalks.
- Do not operate the machine under the influence of alcohol or drugs.
- Use care when loading or unloading the machine into a trailer or truck.
- Use care when approaching blind corners, shrubs, trees, or other objects that may obscure vision.

Maintenance and Storage

- Keep all nuts, bolts and screws tight to be sure the equipment is in safe working condition.
- Never store the equipment with fuel in the tank inside a building where fumes may reach an open flame or spark.
- Allow the engine to cool before storing in any enclosure.
- To reduce the fire hazard, keep the engine, muffler, battery compartment and fuel storage area free of grass, leaves, or excessive grease.
- Keep all parts in good working condition and all hardware and hydraulic fittings tightened. Replace all worn or damaged parts and decals.
- If the fuel tank has to be drained, do this outdoors.
- Be careful during adjustment of the machine to prevent entrapment of the fingers between moving parts and fixed parts of the machine.
- Disengage drives, lower the attachment, set parking brake, stop engine and remove key. Wait for all movement to stop before adjusting, cleaning or repairing.
- Use jack stands to support components when required.
- Carefully release pressure from components with stored energy.
- Disconnect battery and remove spark plug wire before making any repairs. Disconnect the negative

terminal first and the positive last. Reconnect positive first and negative last.

- Keep hands and feet away from moving parts. If possible, do not make adjustments with the engine running.
- Charge batteries in an open well ventilated area, away from spark and flames. Unplug charger before connecting or disconnecting from battery. Wear protective clothing and use insulated tools.
- Make sure all hydraulic line connectors are tight and all hydraulic hoses and lines are in good condition before applying pressure to the system.
- Keep your body and hands away from pin hole leaks or nozzles that eject hydraulic fluid under high pressure. Use paper or cardboard, not your hands, to search for leaks. Hydraulic fluid escaping under pressure can have sufficient force to penetrate the skin and cause serious injury. Seek immediate medical attention if fluid is injected into skin.
- Before disconnecting or performing any work on the hydraulic system, all pressure in the system must be relieved by stopping the engine and lowering the attachments to the ground.
- Check all fuel lines for tightness and wear on a regular basis. Tighten or repair them as needed.
- If the engine must be running to perform a maintenance adjustment, keep hands, feet, clothing, and any parts of the body away from the attachments and any moving parts, especially the screen at the side of the engine. Keep everyone away.
- To ensure safety and accuracy, have an Authorized Toro Distributor check the maximum engine speed with a tachometer.
- If major repairs are ever needed or if assistance is desired, contact an Authorized Toro Distributor. Use

only Toro-approved attachments and replacement parts. The warranty may be voided if used with unapproved attachments.

Sound Pressure Level

This unit has a maximum sound pressure level at the operator's ear of 84.5 dBA, based on measurements of identical machines per Directive 98/37/EC.

Sound Power Level

This unit has a guaranteed sound power level of 100 dBA/1 pW, based on measurements of identical machines per EN 11094.

Vibration Level

Hand-Arm

This unit does not exceed a vibration level of 2.5 m/s² at the hands based on measurements of identical machines per EN 1033.

Whole Body

This unit does not exceed a vibration level of 0.5 m/s² at the posterior based on measurements of identical machines per EN 1032.

Safety and Instructional Decals



Safety decals and instructions are easily visible to the operator and are located near any area of potential danger. Replace any decal that is damaged or lost.

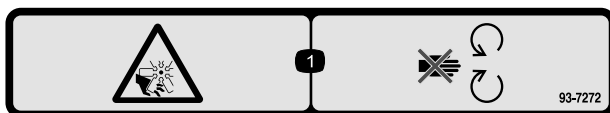

93-7272

1. Cutting/dismemberment hazard; fan—stay away from moving parts.

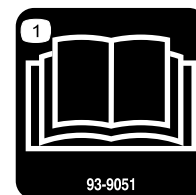

93-9051

1. Read the *Operator's Manual*.

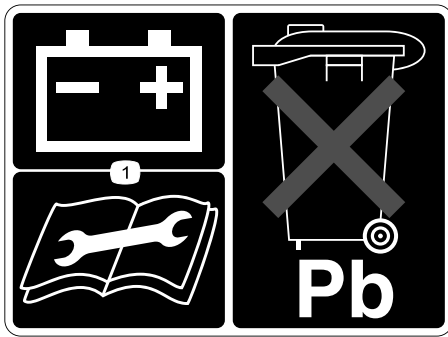

93-6668

1. Read the *Operator's Manual* for information on charging the battery; contains lead; do not discard.



Battery Symbols

Some or all of these symbols are on your battery

- | | |
|--|--|
| 1. Explosion hazard | 6. Keep bystanders a safe distance from the battery. |
| 2. No fire, open flame, or smoking. | 7. Wear eye protection; explosive gases can cause blindness and other injuries |
| 3. Caustic liquid/chemical burn hazard | 8. Battery acid can cause blindness or severe burns. |
| 4. Wear eye protection | 9. Flush eyes immediately with water and get medical help fast. |
| 5. Read the <i>Operator's Manual</i> . | 10. Contains lead; do not discard. |

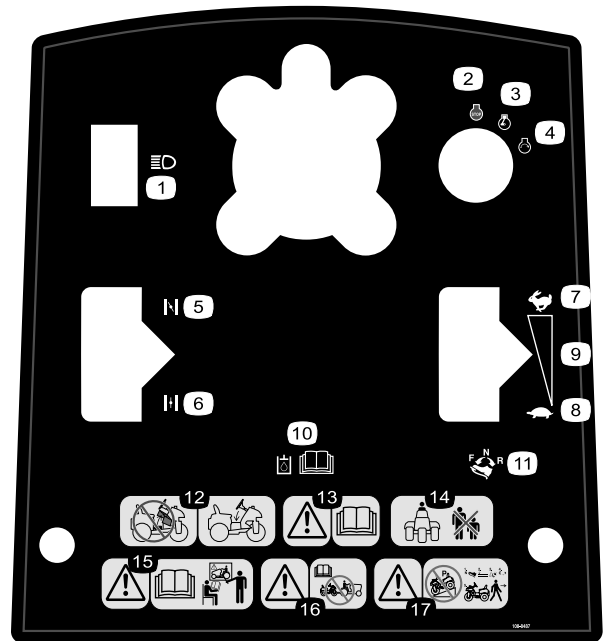

108-8487

1. Headlights
2. Engine—stop
3. Engine—run
4. Engine—start
5. Choke—closed
6. Choke—open
7. Fast
8. Slow
9. Continuous variable setting
10. Read the *Operator's Manual* for hydraulic oil information.
11. To drive forward, press the top of the traction control pedal forward and down; to drive in reverse, press the bottom of the traction control pedal rearward and down.
12. Do not operate without center shroud in place.
13. Warning—read the *Operator's Manual*.
14. Keep bystanders a safe distance from the machine.
15. Warning—read the *Operator's Manual* and receive training.
16. Warning—read the *Operator's Manual*; do not tow the machine.
17. Warning—do not park the machine on a slope; before leaving the machine, put the traction control pedal in neutral, lower the attachment, turn the engine off, and remove the ignition key.

SAND/INFIELD PRO 5040/3040
QUICK REFERENCE AID
CHECK/SERVICE (DAILY)

- OIL LEVEL, ENGINE
- OIL LEVEL, HYDRAULIC TANK
- NEUTRAL INTERLOCK SWITCH
- AIR FILTER
- ENGINE COOLING FINS
- TIRE PRESSURE (4 - 6 psi / .3-.4 bar)
- WHEEL NUT TORQUE (45-55 FT-LBS / 61-75 N·m)
- BATTERY
- FUEL - GAS ONLY
- SEAT INTERLOCK SWITCH
- LUBRICATION → EVERY 100 HRS
 ▲ (5040 ONLY)

FLUID SPECIFICATION / CHANGE INTERVALS

SEE OPERATOR'S MANUAL FOR INITIAL CHANGE	FLUID TYPE	CAPACITY	CHANGE INTERVALS		FILTER PART NO.
			FLUID	FILTER	
ENGINE OIL	SAE 30 SJ	* 1 3/4 QTS	50 HRS.	50 HRS.	107-7817 (A)
HYDRAULIC OIL	Mobil DTE 15M	* 5 GAL. ■	400 HRS.	400 HRS.	54-0110 (B)
AIR CLEANER (ON FENDER)				**200 HRS.	93-2195 (C)
FUEL TANK/FILTER	UNLEADED GAS	5 1/2 GAL.		+800 HRS.	94-2690 (D)

* INCLUDING FILTER ** INSPECT EVERY 50 HRS., MORE OFTEN UNDER DUSTY CONDITIONS + OR YEARLY, WHICH EVER IS LESS
 ■ 6.75 GAL W/ REMOTE HYDRAULICS

108-8418

108-8418

108-8484

- Attachment control
- Attachment lower position
- Attachment raise position
- Attachment, locked in float position
- Parking brake
- PTO—disengaged
- PTO—engaged

Setup

Loose Parts

Use the chart below to verify that all parts have been shipped.

Procedure	Description	Qty.	Use
1	Steering wheel	1	Install the steering wheel.
	Foam collar	1	
	Washer	1	
	Locknut	1	
2	No parts required	–	Remove the battery.
3	Bulk electrolyte, 1.260 specific gravity (not included)	-	Activate and charge the battery.
4	Bolt (1/4 x 5/8 inch)	2	Install the battery
	Locknut (1/4 inch)	2	
5	Infield Pro decal	1	Install the Infield Pro® decal (optional).
6	Operator's Manual	1	Read the manuals and watch the video before operating the machine.
	Engine Operator's Manual	1	
	Parts Catalog	1	
	Operator Video	1	
	Pre-delivery Inspection Sheet	1	
	Key	2	
7	Front weight kit(s) as needed	-	Install front weights if needed.

Note: Determine the left and right sides of the machine from the normal operating position.

Note: Remove and discard all the shipping brackets and fasteners.

1

Installing the Steering Wheel

Parts needed for this procedure:

1	Steering wheel
1	Foam collar
1	Washer
1	Locknut

Procedure

1. Move the front wheel so that it points straight ahead.
2. Slide the foam collar onto the steering shaft (Figure 2).

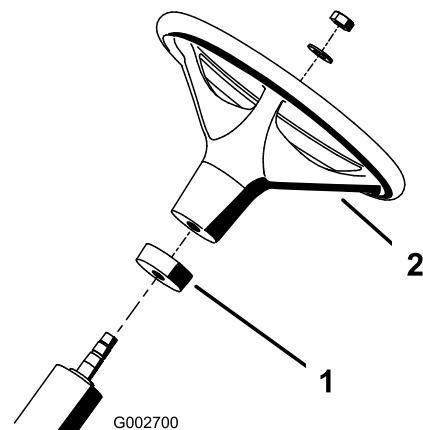

Figure 2

1. Foam collar
2. Steering wheel

3. Slide the steering wheel onto the steering shaft (Figure 2).
4. Secure the steering wheel to the steering shaft with a washer and locknut (Figure 2). Torque the locknut to 20–26 ft-lbs (27–35 N·m).

2

Removing the Battery

No Parts Required

Procedure

Remove the (2) wing nuts and washers securing top battery hold down to side battery hold downs (Figure 3). Remove top battery hold and remove battery.

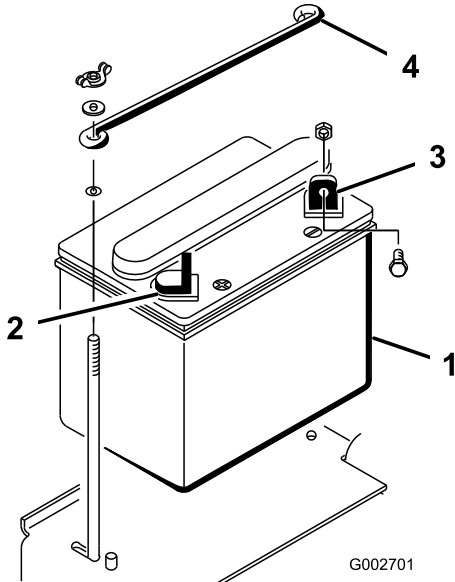

Figure 3

- | | |
|----------------------------------|----------------------------------|
| 1. Battery | 3. Negative (-) battery terminal |
| 2. Positive (+) battery terminal | 4. Top battery hold down |

3

Activating and Charging the Battery

Parts needed for this procedure:

- | | |
|---|---|
| - | Bulk electrolyte, 1.260 specific gravity (not included) |
|---|---|

Procedure

Warning

CALIFORNIA

Proposition 65 Warning

Battery posts, terminals, and related accessories contain lead and lead compounds, chemicals known to the State of California to cause cancer and reproductive harm. Wash hands after handling.

If the battery is not filled with electrolyte or activated, bulk electrolyte with 1.260 specific gravity must be purchased from a local battery supply outlet and added to the battery.



Battery electrolyte contains sulfuric acid which is a deadly poison and causes severe burns.

- Do not drink electrolyte and avoid contact with skin, eyes or clothing. Wear safety glasses to shield your eyes and rubber gloves to protect your hands.
- Fill the battery where clean water is always available for flushing the skin.

1. Remove the filler caps from the battery and slowly fill each cell until electrolyte is up to the fill line.
2. Replace the filler caps and connect a 3 to 4 amp. battery charger to the battery posts. Charge the battery at a rate of 3 to 4 amperes for 4 to 8 hours.



Charging the battery produces gasses that can explode.

Never smoke near the battery and keep sparks and flames away from battery.

- When the battery is charged, disconnect the charger from the electrical outlet and battery posts. Allow the battery to sit for 5-10 minutes.
- Remove the filler caps. Slowly add electrolyte to each cell until the level is up to the fill line. Install the filler caps.

Important: Do not overfill the battery. Electrolyte will overflow onto other parts of the machine and severe corrosion and deterioration will result.

4

Installing the Battery

Parts needed for this procedure:

2	Bolt (1/4 x 5/8 inch)
2	Locknut (1/4 inch)

Procedure

- Set the battery in place, with the negative terminal positioned to the rear of the machine (Figure 4).

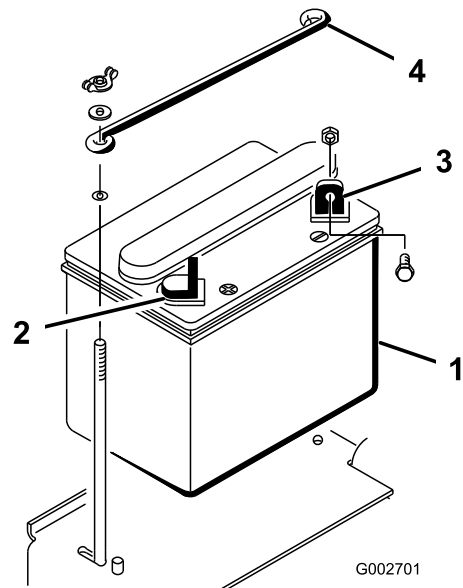

Figure 4

- Battery
- Positive (+) battery terminal
- Negative (-) battery terminal
- Top battery hold down

- Secure the positive cable (red) to the positive (+) terminal with a 1/4-20 x 5/8 inch bolt and locknut (Figure 5).

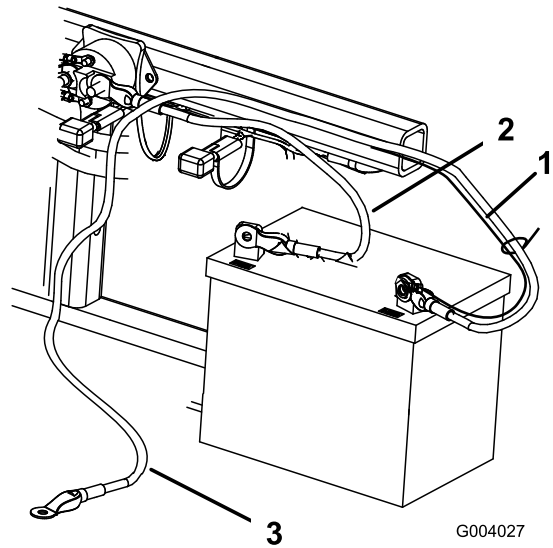

Figure 5

- Small black cable
- Positive (+) battery cable
- Negative (-) battery cable



Incorrect battery cable routing could damage the machine and cables causing sparks. Sparks can cause the battery gasses to explode, resulting in personal injury.

- Always disconnect the negative (black) battery cable before disconnecting the positive (red) cable.
- Always connect the positive (red) battery cable before connecting the negative (black) cable.



Battery terminals or metal tools could short against metal machine components causing sparks. Sparks can cause the battery gasses to explode, resulting in personal injury.

- When removing or installing the battery, do not allow the battery terminals to touch any metal parts of the machine.
- Do not allow metal tools to short between the battery terminals and metal parts of the machine.

3. Secure the small black wire and the negative cable (black) to the negative (-) terminal of the battery with a bolt (1/4 x 5/8 inch) and locknut (1/4 inch) (Figure 5).
4. Coat the terminals and mounting fasteners with petroleum jelly to prevent corrosion. Slide the rubber boot over the positive (+) terminal to prevent a possible short from occurring.
5. Install the top battery hold down to side battery hold downs and secure with washers and wing nuts.

5

Installing the Infield Pro® Decal (Optional)

Parts needed for this procedure:

1	Infield Pro decal
---	-------------------

Procedure

Align and stick the Infield Pro decal over the Sand Pro decal, if desired.

6

Reading the Manuals and Viewing the Video

Parts needed for this procedure:

1	<i>Operator's Manual</i>
1	<i>Engine Operator's Manual</i>
1	<i>Parts Catalog</i>
1	Operator Video
1	Pre-delivery Inspection Sheet
2	Key

Procedure

1. Read the manuals.
2. View the Operator video.
3. Store the documentation in a safe place.

7

Installing Front Weights

Parts needed for this procedure:

-	Front weight kit(s) as needed
---	-------------------------------

Procedure

The Sand/Infield Pro traction unit complies with CEN standard EN 836:1997 and the ANSI B71.4-2004 Standard at the time of production. However, when the following attachments are installed on the machine additional weight is required to comply to the standards. Use the chart below to determine the combinations of additional weight required. Order parts from your local Authorized Toro Distributor.

Attachment	Additional Front Weight Required	Weight Kit Part Number	Weight Description	Qty.
Spiker kit (08755)	50 lb.	100-6442	8 x 6.5 lb plate weight	1
Rahn Groomer	50 lb.	100-6442	8 x 6.5 lb plate Weight	1

Note: Additional weight is not required if the machine is equipped with a front attachment.

Product Overview

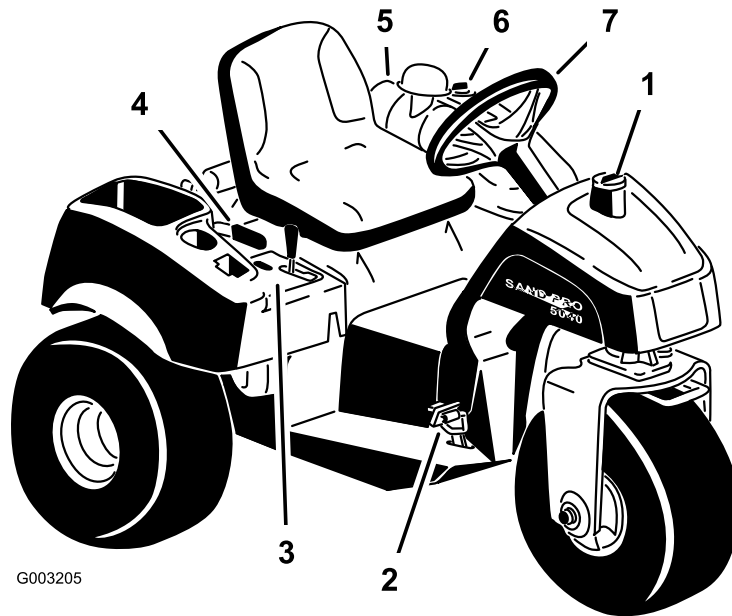

G003205

Figure 6

- | | | | |
|--------------------------------|------------------|-----------------------|-------------------|
| 1. Fuel tank cap | 3. Control panel | 5. Air cleaner | 7. Steering wheel |
| 2. Traction and stopping pedal | 4. Parking lever | 6. Hydraulic tank cap | |

Controls

Traction and Stopping Pedal

The traction pedal (Figure 7) has 3 functions: to make the machine move forward, to move it backward, and to stop the machine. Using the heel and toe of the right foot, depress the top of the pedal to move forward and the bottom of pedal to move backward or to assist in stopping when moving forward (Figure 8). Also, allow the pedal to move or move it to the neutral position to stop the machine. For operator comfort, **do not the rest heel of the foot on reverse when operating forward.**

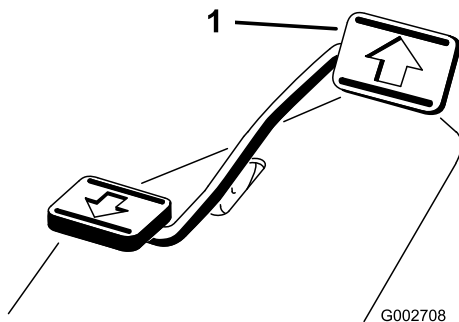

G002708

Figure 7

1. Traction and stopping pedal



G002709

Figure 8

Ground speed is proportionate to how the far traction pedal is depressed. For maximum ground speed, the pedal must be fully depressed while the throttle is in the Fast position. To get maximum power or when ascending a hill, have the throttle in the Fast position while depressing the pedal slightly to keep the engine RPM high. When the engine RPM begins to decrease, release the pedal slightly to allow the RPM to increase.

Important: For maximum pulling power, the throttle should be in the Fast position and the traction pedal just barely depressed.



Use the maximum ground speed only when driving from one area to another.

Maximum speed is not recommended when using an attached or towed attachment.

Important: Do not operate in reverse with a rear attachment in the down (operating) position, or the attachment could be severely damaged.

Ignition Switch

The ignition switch (Figure 9), used to start and stop the engine, has three positions: Off, Run, and Start. Rotate the key clockwise to the Start position to engage the starter motor. Release the key when the engine starts. The key will move automatically to the On position. To shut the engine off, rotate the key counterclockwise to the Off position.

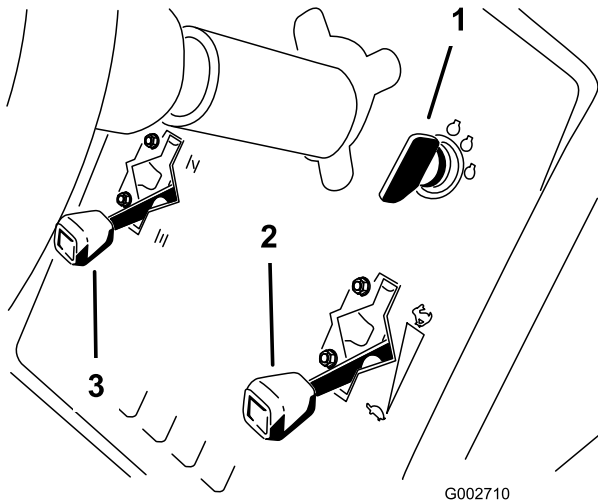

Figure 9

Choke Control

To start a cold engine, close carburetor choke by moving choke control (Figure 9) forward to the Closed position. After engine starts, regulate choke to keep engine running smoothly. As soon as possible, open the choke by pulling upward to the Open position. A warm engine requires little or no choking.

Throttle Control

The throttle control lever (Figure 9) connects to and operates the throttle linkage to the carburetor. The control has 2 positions: Slow and Fast. The engine speed can be varied between the 2 settings.

Note: The engine cannot be stopped by the throttle control.

Lift Lever

To raise the attachment, pull the lift lever (Figure 10) back; to lower the attachment, push the lever forward. For the float position, move the lever into the detent position. When the desired position is attained, release the lever and it will return to neutral.

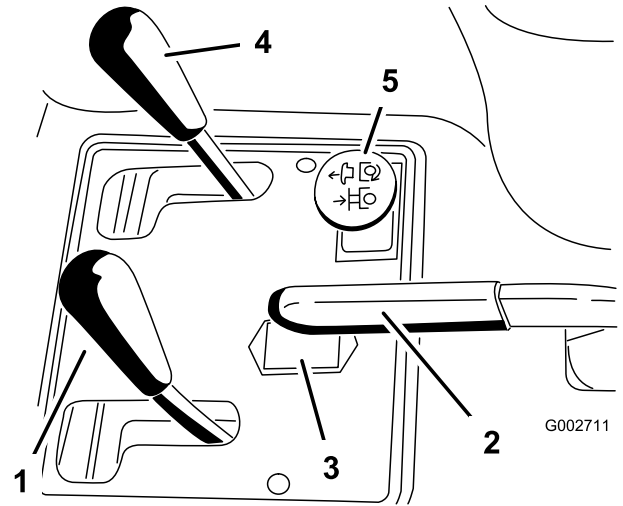

Figure 10

- | | |
|------------------|--|
| 1. Lift lever | 4. Front lift control (optional) |
| 2. Parking brake | 5. Rear remote hydraulics control (optional) |
| 3. Hour meter | |

Note: The machine has a double-acting lift cylinder. Down pressure can be applied to the attachment for certain operating conditions.

Parking Brake

To engage the parking brake (Figure 10), pull back on the parking brake lever. To disengage it, push the lever forward.

Note: The traction pedal may have to be rotated slowly forward and backward to release the parking brake.

Hour Meter

The hour meter (Figure 10) indicates the total hours of machine operation. The hour meter starts to function whenever the key switch is rotated to the On position.

Seat Adjustment Lever

Move the lever on the left side of the seat (Figure 11) forward, slide the seat to the desired position, and release the lever to lock the seat into position.

Attachments/Accessories

A selection of Toro approved attachments and accessories are available for use with the machine to enhance and expand its capabilities. Contact your Authorized Service Dealer or Distributor or go to www.Toro.com for a list of all approved attachments and accessories.

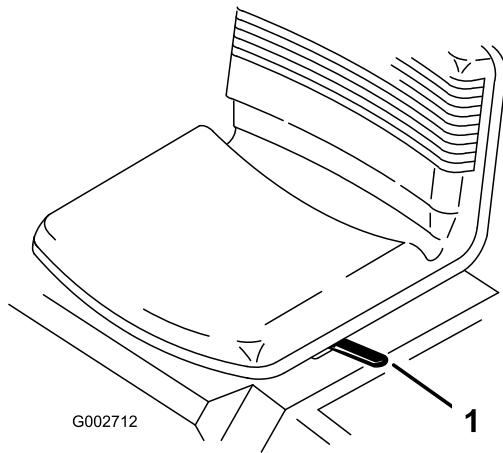

Figure 11

1. Seat adjusting lever

Fuel Shutoff Valve

Close the fuel shutoff valve (Figure 12) when storing or trailering the machine.

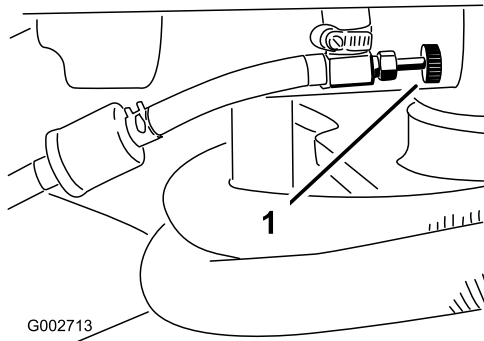

Figure 12

1. Fuel shutoff valve

Specifications

Note: Specifications and design are subject to change without notice.

Width without attachment	58 inches (148 cm)
Width with rake, model number 08751	75 inches (191 cm)
Length without attachment	64-1/2 inches (164 cm)
Height	45-1/4 inches (115 cm)
Wheelbase	42-3/4 inches (109 cm)
Net weight (wet)	920 lb (417 kg)

Operation

Note: Determine the left and right sides of the machine from the normal operating position.

Checking the Engine Oil Level

Service Interval: Before each use or daily

The engine is shipped with oil in the crankcase; however, the oil level must be checked before and after the engine is first started.

Crankcase capacity is approximately 1-3/4 US quarts (1.66 l) with the filter.

Use high-quality engine oil that meets the following specifications:

- API Classification Level Required: SJ, SK, SL or higher.
 - Preferred oil: SAE 30 (above 40 degrees F)
1. Position the machine on a level surface.
 2. Pivot seat forward.
 3. Pull out the dipstick (Figure 13) and wipe it with a clean rag. Insert the dipstick into the tube and make sure that it is seated fully. Remove the dipstick from the tube and check the oil level. If the oil level is low, remove the filler cap from the valve cover and add enough oil to raise the level to the Full mark on the dipstick.

Important: Be sure to keep the engine oil level between the upper and lower limits on the oil gauge. Engine failure may occur as a result of over filling or under filling the engine oil.

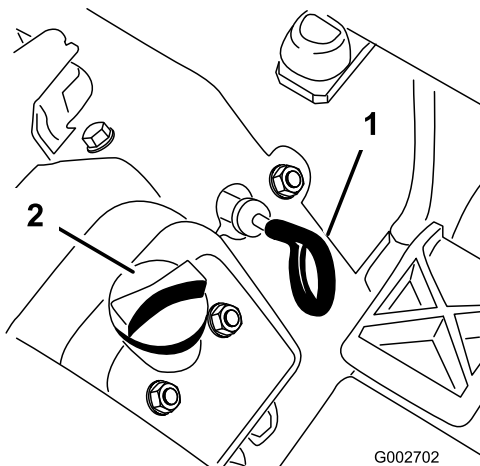

Figure 13

1. Dipstick

2. Oil fill cap

4. Install the dipstick firmly in place.

Important: The dipstick must be fully seated in the tube to provide proper sealing of the engine crankcase. Failure to seal the crankcase may result in engine damage.

5. Pivot the seat down.

Important: Check the oil level every 8 operating hours or daily. Initially, change the oil after the first 8 hours of operation; thereafter, under normal conditions, change the oil and filter every 50 hours. However, change the oil more frequently when the engine is operated in extremely dusty or dirty conditions.

Filling the Fuel Tank

Use **Unleaded** regular gasoline suitable for automotive use (87 pump octane minimum). Leaded regular gasoline may be used if unleaded regular is not available.

Fuel tank capacity is approximately 5-1/2 gallons (25 l).



In certain conditions, gasoline is extremely flammable and highly explosive. A fire or explosion from gasoline can burn you and others and can damage property.

- Fill the fuel tank outdoors, in an open area, when the engine is cold. Wipe up any gasoline that spills.
- Never fill the fuel tank inside an enclosed trailer.
- Do not fill the fuel tank completely full. Add gasoline to the fuel tank until the level is 1/4 to 1/2 inch (6 to 13 mm) below the bottom of the filler neck. This empty space in the tank allows gasoline to expand.
- Never smoke when handling gasoline, and stay away from an open flame or where gasoline fumes may be ignited by a spark.
- Store gasoline in an approved container and keep it out of the reach of children. Never buy more than a 30-day supply of gasoline.
- Do not operate without entire exhaust system in place and in proper working condition.



In certain conditions during fueling, static electricity can be released causing a spark which can ignite the gasoline vapors. A fire or explosion from gasoline can burn you and others and can damage property.

- Always place gasoline containers on the ground away from your vehicle before filling.
- Do not fill gasoline containers inside a vehicle or on a truck or trailer bed because interior carpets or plastic truck bed liners may insulate the container and slow the loss of any static charge.
- When practical, remove gas-powered equipment from the truck or trailer and refuel the equipment with its wheels on the ground.
- If this is not possible, then refuel such equipment on a truck or trailer from a portable container, rather than from a gasoline dispenser nozzle.
- If a gasoline dispenser nozzle must be used, keep the nozzle in contact with the rim of the fuel tank or container opening at all times until fueling is complete.



Gasoline is harmful or fatal if swallowed. Long-term exposure to vapors can cause serious injury and illness.

- Avoid prolonged breathing of vapors.
- Keep face away from nozzle and gas tank or conditioner opening.
- Keep gas away from eyes and skin.

1. Clean the area around the fuel tank cap (Figure 14).

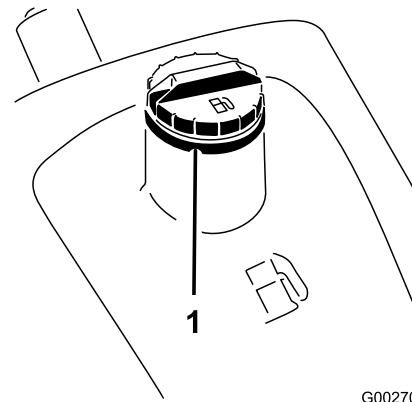

Figure 14

1. Fuel tank cap
2. Remove the fuel tank cap.
3. Fill the tank to about 1 in. (25 mm) below the top of the tank (bottom of the filler neck). **Do not overfill.** Install the cap.
4. Wipe up any fuel that may have spilled to prevent a fire hazard.

Important: Never use methanol, gasoline containing methanol, or gasohol containing more than 10% ethanol because the fuel system could be damaged. Do not mix oil with gasoline.

Checking the Hydraulic Fluid Level

Service Interval: Before each use or daily

The reservoir is filled at the factory with approximately 5 U.S. gallons (13.2 l) of high quality hydraulic fluid.

Check the level of the hydraulic fluid before the engine is first started and daily thereafter. The recommended replacement fluid is as follows:

Toro Premium All Season Hydraulic Fluid (Available in 5 gallon pails or 55 gallon drums. See parts catalog or Toro distributor for part numbers.)

Alternate fluids: If the Toro fluid is not available, other fluids may be used provided they meet all the following material properties and industry specifications. We do not recommend the use of synthetic fluid. Consult with your lubricant distributor to identify a satisfactory product

Note: Toro will not assume responsibility for damage caused by improper substitutions, so use only products from reputable manufacturers who will stand behind their recommendation.

High Viscosity Index/Low Pour Point Antiwear Hydraulic Fluid, ISO VG 46

Material Properties:

Viscosity, ASTM D445 cSt @ 40°C 44 to 48
cSt @ 100°C 9.1 to 9.8

Viscosity Index ASTM D2270 140 to 160

Pour Point, ASTM D97 -34°F to -49°F

Industry Specifications:

Vickers I-286-S (Quality Level), Vickers M-2950-S (Quality Level), Denison HF-0

Note: Many hydraulic fluids are almost colorless, making it difficult to spot leaks. A red dye additive for the hydraulic system oil is available in 2/3 oz. (20 ml) bottles. One bottle is sufficient for 4-6 gal (15-22 l) of hydraulic oil. Order part number 44-2500 from your authorized Toro distributor.

Biodegradable Hydraulic Fluid - Mobil 224H

Toro Biodegradable Hydraulic Fluid

(Available in 5 gallon pails or 55 gallon drums. See parts catalog or Toro distributor for part numbers.)

Alternate fluid: Mobil EAL 224H

This is vegetable-oil based biodegradable oil tested and approved by Toro for this model. This fluid is not as resistant to high temperatures as standard fluid, so install an oil cooler if required by the operator manual and follow recommended fluid change intervals with this fluid. Contamination by mineral-based hydraulic fluids will change the biodegradability and toxicity of this oil. When changing from standard fluid to the biodegradable type, be certain to follow the approved flushing procedure. Contact your local Toro Distributor for details.

1. Clean the area around the hydraulic oil reservoir cap to prevent debris from entering tank (Figure 15).

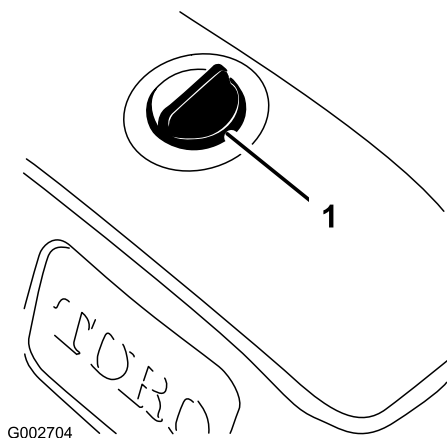

Figure 15

1. Oil reservoir cap

2. Remove the cap from the reservoir.

3. Remove dipstick from filler neck and wipe it with a clean rag. Insert dipstick into filler neck; then remove it and check level of fluid. Fluid level should be up to mark (necked down area) on dipstick (Figure 16).

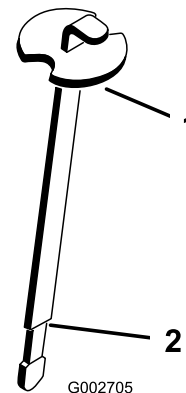

Figure 16

1. Dipstick
2. Full mark

4. If the fluid level is low, slowly fill the reservoir with the appropriate hydraulic fluid until the level reaches the necked down area on the dipstick. Do not overfill.
5. Install the reservoir cap.

Important: To prevent system contamination, clean the top of the hydraulic oil container before puncturing. Ensure that the pour spout and funnel are clean.

Checking the Tire Pressure

Service Interval: Before each use or daily

Check the tire pressure before operating the machine (Figure 17). The correct air pressure in the front and rear tires are:

- for Treaded tires 4-6 psi (0.3-0.4 bar)
- for Smooth tires 8-10 psi (0.5-0.7 bar)

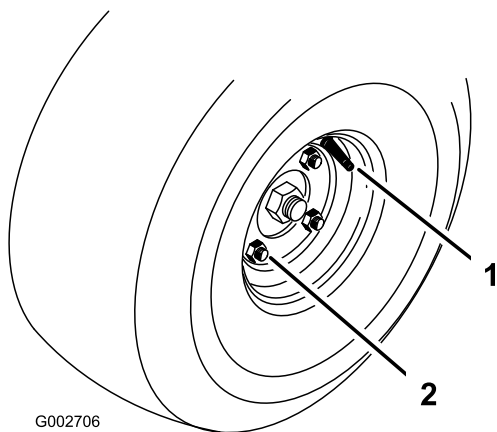

Figure 17

1. Valve stem

2. Lug nut

Torquing the Wheel Lug Nuts

Service Interval: After the first 8 hours
Every 100 hours

Initially, torque the wheel lugs after the first 8 hours of operation; thereafter, torque the nuts after every 100 operating hours. Torque the lugs nuts to 45-55 ft-lb (61-75 N·m).

Starting and Stopping the Engine

1. Remove your foot from the traction pedal, make sure that the pedal is in the neutral position, and engage the parking brake.
2. Push the choke lever forward to the On position (when starting a cold engine) and the throttle lever to the Slow position.

Important: When operating the machine in temperatures less than 32°F (0°C) allow the machine time to warm up before using. This prevents damage to the hydrostat and the traction loop.

3. Insert the key into the ignition switch and rotate it clockwise to start the engine. Release the key when the engine starts. Regulate the choke to keep the engine running smoothly.

Important: To prevent overheating of the starter motor, do not engage the starter longer than 10 seconds. After 10 seconds of continuous cranking, wait 60 seconds before engaging the starter motor again.

4. When the engine is started for the first time, or after an overhaul of the engine, operate the machine in forward and reverse for 1 to 2 minutes. Also

operate the lift lever to be sure of proper operation of all parts.

5. To stop the engine, move the throttle control to the Slow position and rotate the ignition key to Off. Remove the key from the switch to prevent accidental starting.
6. Close the fuel shutoff valve before storing the machine.



Shut the engine off and wait for all moving parts to stop before checking for oil leaks, loose parts, and other malfunctions.

Checking the Interlock System



If safety interlock switches are disconnected or damaged the machine could operate unexpectedly causing personal injury.

- Do not tamper with the interlock switches.
- Check the operation of the interlock switches daily and replace any damaged switches before operating the machine.
- Replace switches every two years regardless of whether they are operating properly or not.

The purpose of the interlock system is to prevent the engine from cranking or starting unless the traction pedal is in the neutral position. Also, the engine should stop if the traction pedal is moved either forward or reverse without an operator in the seat.

1. Check the interlock operation in a wide open area free of debris and bystanders. Stop the engine.
2. Sit on the seat and engage the parking brake. Depress the traction pedal in forward and reverse while trying to start the engine. If the engine cranks, there may be a malfunction in the interlock system. Repair it immediately. If the engine does not crank, the system is operating correctly.
3. With the operator in the seat, traction pedal in neutral and parking brake on, the engine should start. Lift off the seat and slowly depress the traction pedal, the engine should stop in one to three seconds. Correct problem if not operating properly.

Towing the Machine

In case of emergency, the machine can be towed for a short distance. However, we do not recommend this as a standard procedure.

Important: Do not tow the machine faster than 1 MPH (1.6 km/h) because the drive system may be damaged. If the machine must be moved more than 50 yards, transport it on a truck or trailer. The tires may lock up if the machine is towed too fast. If this occurs, stop towing the machine and wait for the traction circuit pressure to stabilize before resuming towing at a slower speed.

Break-in Period

Only 8 hours of operating time is required for the break-in period.

Since the first hours of operation are critical to future dependability of the machine, monitor its functions and performance closely so that minor difficulties, which could lead to major problems, are noted and can be corrected. Inspect the machine frequently during break-in for signs of oil leakage, loose fasteners, or any other malfunction.

Operating Characteristics

Practice driving the machine because its operating characteristics are different than some utility vehicles. Two points to consider when operating the vehicle are transmission and engine speed.

To maintain somewhat constant engine RPM, depress the traction pedal slowly. This allows the engine to keep up with the ground speed of the vehicle. By contrast, pushing down quickly on the traction pedal will reduce engine RPM and, as a result, there will not be enough torque-power to move the vehicle. Therefore, to transfer maximum power to the wheels, move the throttle to Fast and slightly depress the traction pedal. By comparison, maximum ground speed with no load results when the throttle is in the Fast position and the traction pedal is slowly but fully depressed. In summary, always keep the engine RPM high enough to deliver maximum torque-power to the wheels.



Operating the machine demands attention to prevent tipping or loss of control.

- Use care when entering and leaving sand traps.
- Use extreme caution around ditches, creeks, or other hazards.
- Use caution when operating the machine on a steep slope.
- Reduce your speed when making sharp turns or when turning on hillsides.
- Avoid sudden stops and starts.
- Do not go from reverse to full forward without first coming to a complete stop.

Note: If the attachment adapter becomes stuck to the traction unit adapter, insert a prybar/screwdriver into the pry slot to disengage the parts (Figure 18).

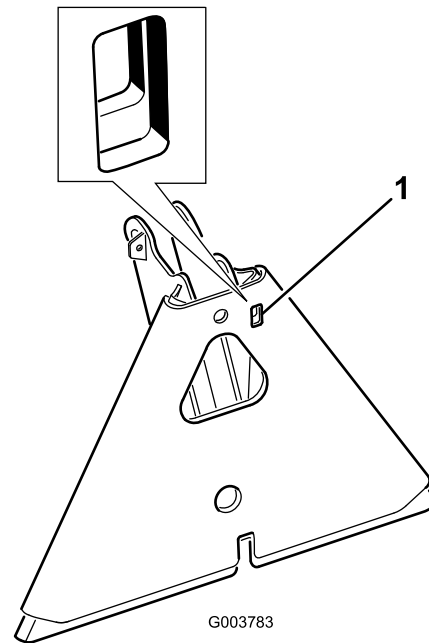

Figure 18

1. Pry slot

Maintenance

Note: Determine the left and right sides of the machine from the normal operating position.



If you leave the key in the ignition switch, someone could accidentally start the engine and seriously injure you or other bystanders.

Remove the key from the ignition before you do any maintenance.

Recommended Maintenance Schedule(s)

Maintenance Service Interval	Maintenance Procedure
After the first 8 hours	<ul style="list-style-type: none"> • Torque the wheel lug nuts. • Change the engine oil and filter. • Change the hydraulic filter.
Before each use or daily	<ul style="list-style-type: none"> • Check the engine oil level. • Check the hydraulic fluid level. • Check the tire pressure. • Check the condition of the hydraulic lines and hoses. • Inspect and clean the machine.
Every 25 hours	<ul style="list-style-type: none"> • Check the battery fluid level and the cable connections.
Every 50 hours	<ul style="list-style-type: none"> • Change the engine oil and filter.
Every 100 hours	<ul style="list-style-type: none"> • Torque the wheel lug nuts. • Grease the machine.
Every 200 hours	<ul style="list-style-type: none"> • Replace the air filter.
Every 400 hours	<ul style="list-style-type: none"> • Change the hydraulic system oil and filter.
Every 800 hours	<ul style="list-style-type: none"> • Replace the spark plugs. • Replace the fuel filter. • Decarbon the combustion chamber. • Adjust the valves and torque head. • Check the engine RPM (at idle and full throttle). • Drain and clean the fuel tank.
Every 1,500 hours	<ul style="list-style-type: none"> • Replace moving hoses. • Replace the neutral and seat interlock switches.

Important: Refer to your *Engine Operator's Manual* for additional maintenance procedures.

Daily Maintenance Checklist

Duplicate this page for routine use.

Maintenance Check Item	For the week of:						
	Mon.	Tues.	Wed.	Thurs.	Fri.	Sat.	Sun.
Check the safety interlock operation.							
Check the steering operation.							
Check fuel level.							
Check the engine oil level.							
Check the air filter condition.							
Clean the engine cooling fins.							
Check unusual engine noises.							
Check unusual operating noises.							
Check the hydraulic oil level.							
Check hydraulic hoses for damage.							
Check for fluid leaks.							
Check the tire pressure.							
Check the instrument operation.							
Touch-up damaged paint.							

Notation for Areas of Concern		
Inspection performed by:		
Item	Date	Information

Premaintenance Procedures

Jacking the Machine



Before servicing, support the machine with jacks stands or blocks of wood.

The jacking points are as follows:

- Left or right side-under the rear wheel motor or the frame (Figure 19).

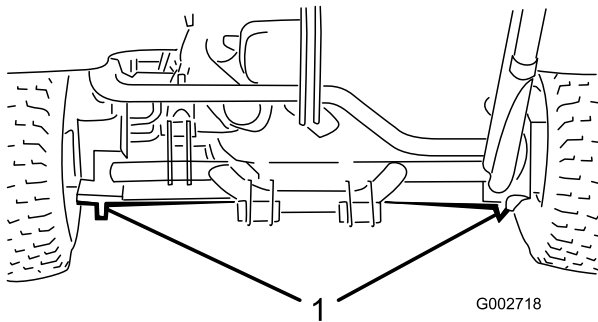

Figure 19

1. Rear jacking points

- Front-under the frame behind the front wheel (Figure 20).

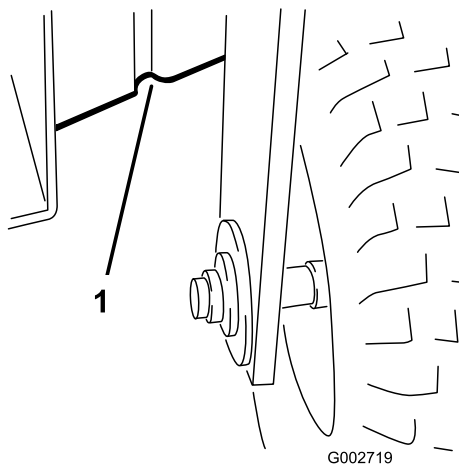

Figure 20

1. Front jacking points

Lubrication

The machine has grease fittings that must be lubricated regularly with No. 2 General Purpose Lithium Base Grease after every 100 hours of operation.

Lubricate the following bearings and bushings:

- Front wheel bearing (1) (Figure 21)

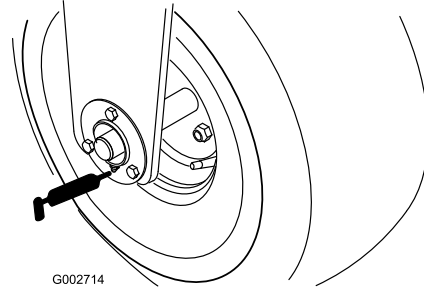

Figure 21

- Traction pedal pivot (1) (Figure 22)

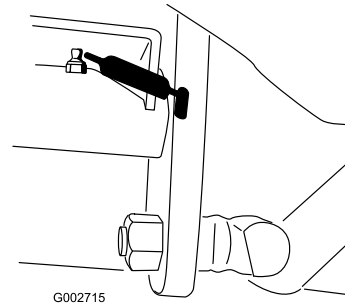

Figure 22

- Rear hitch (5) (Figure 23)

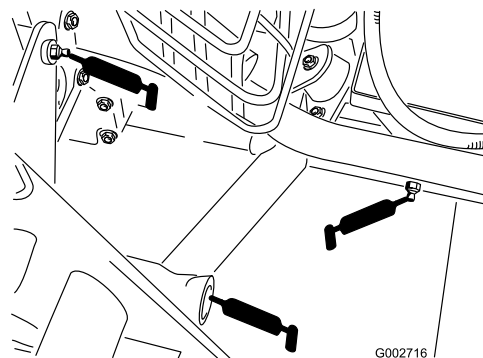

Figure 23

- Steering cylinder rod end (1) (Model 08705 only) (Figure 24)



Figure 24

Greasing the Machine

Service Interval: Every 100 hours

1. Wipe the grease fitting clean so that foreign matter cannot be forced into the bearing or bushing.
2. Pump grease into the bearing or bushing.
3. Wipe up excess grease.

Engine Maintenance

Changing the Engine Oil and Filter

Service Interval: After the first 8 hours

Every 50 hours

Change the oil and filter initially after the first 8 hours of operation; thereafter change the oil and the filter every 50 hours.

1. Park the machine on a level surface and turn the engine off.
2. Remove the drain plug (Figure 25) and let oil flow into a drain pan. When the oil stops, install the drain plug.

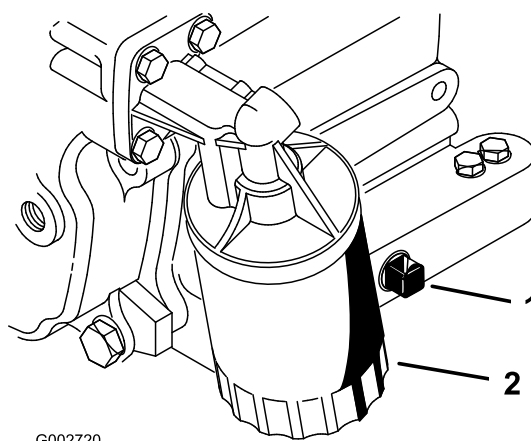

Figure 25

1. Drain plug
2. Oil filter

3. Remove the oil filter (Figure 25). Apply a light coat of clean oil to the new filter gasket.
4. Screw the filter on by hand until the gasket contacts the filter adapter; then tighten 1/2 to 3/4 turn further. Do not overtighten.
5. Add oil to the crankcase; refer to Checking the Crankcase Oil, page 10.
6. Dispose of used oil properly.

Servicing the Air Cleaner

- Check the air cleaner body for damage which could cause an air leak. Replace if damaged. Check the whole intake system for leaks, damage or loose hose clamps.
- Service the air cleaner filter every 200 hours or earlier if engine performance suffers due to extremely dusty, dirty conditions. Changing the air filter before it is

necessary only increases the chance of dirt entering the engine when the filter is removed.

- Be sure the cover is seated correctly and seals with the air cleaner body.

Replacing the Air Filter

Service Interval: Every 200 hours

1. Release the latches securing the air cleaner cover to the air cleaner body (Figure 26).

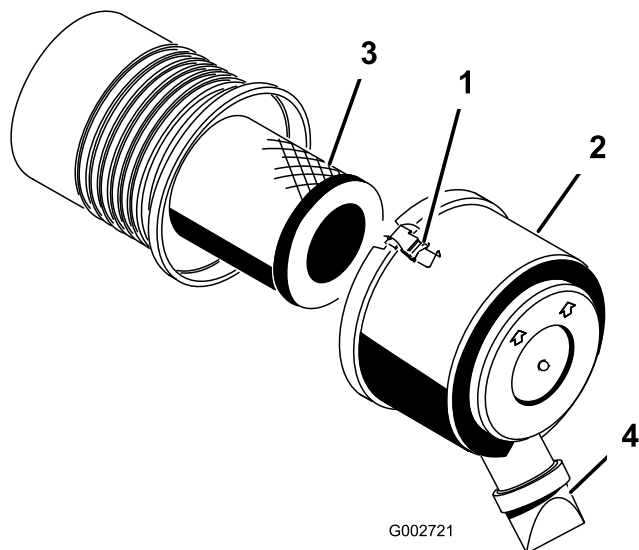

Figure 26

- | | |
|----------------------|-----------------------|
| 1. Air cleaner latch | 3. Air filter |
| 2. Dust cap | 4. Dirt ejection port |

2. Remove the cover from the air cleaner body. Before removing the filter, use low pressure air (40 psi, clean and dry) to help remove large accumulations of debris packed between outside of primary filter and the canister.

Important: Avoid using high pressure air which could force dirt through the filter into the intake tract. This cleaning process prevents debris from migrating into the intake when the primary filter is removed.

3. Remove and replace the filter.

Inspect the new filter for shipping damage, checking the sealing end of the filter and the body. Do not use a damaged element. Insert the new filter by applying pressure to the outer rim of the element to seat it in the canister. Do not apply pressure to the flexible center of the filter.

Note: Cleaning of the used element is not recommended due to the possibility of damage to the filter media.

4. Clean the dirt ejection port located in the removable cover. Remove the rubber outlet valve from the cover, clean the cavity and replace the outlet valve.
5. Install the cover orienting the rubber outlet valve in a downward position - between approximately 5:00 to 7:00 when viewed from the end.
6. Secure the latches.

Replacing the Spark Plugs

Service Interval: Every 800 hours

Replace the spark plugs after every 800 operating hours or yearly, whichever occurs first.

Type: Champion RC14YC (or equivalent)

Air Gap: 0.030 in. (0.76 mm)

Note: The spark plug usually lasts a long time; however, the plug should be removed and checked whenever the engine malfunctions.

1. Clean the area around the spark plugs so that foreign matter cannot fall into the cylinder when the spark plug is removed.
2. Pull the spark plug wires off of the spark plugs and remove the plugs from the cylinder head.
3. Check the condition of the side electrode, center electrode, and center electrode insulator to ensure that there is no damage.

Important: A cracked, fouled, dirty, or otherwise malfunctioning spark plug must be replaced. Do not sand-blast, scrape, or clean the electrodes by using a wire brush because grit may eventually release from the plug and fall into the cylinder. The result is usually a damaged engine.

4. Set the air gap between the center and side of the electrodes at 0.030 in. (0.76 mm) (Figure 27). Install the correctly gapped spark plug with gasket seal, and tighten the plug to 200 in-lb (23 N·m). If a torque wrench is not used, tighten the plug firmly.

Fuel System Maintenance

Replacing the Fuel Filter

Service Interval: Every 800 hours

An in line filter is incorporated into the fuel line. Change the filter every 800 hours. Use the following procedures when replacement becomes necessary:

1. Close fuel shut off valve, loosen the hose clamp on the carburetor side of filter and remove the fuel line from the filter (Figure 28).

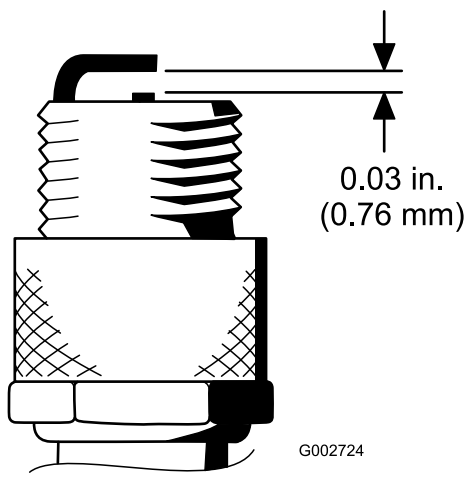

Figure 27

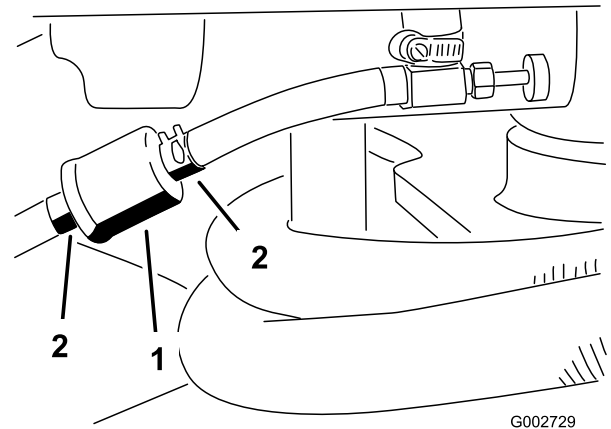

Figure 28

1. Fuel filter
2. Hose clamps

2. Place a drain pan under filter, loosen the remaining hose clamp and remove filter.

3. Install the new filter with arrow on the filter body pointing away from the fuel tank (toward carburetor).
4. Slide the hose clamps onto the ends of the fuel lines. Push the fuel lines onto the fuel filter and secure them with the hose clamps. Be sure that the arrow on the side of the filter points toward the carburetor.

Electrical System Maintenance

Warning

CALIFORNIA
Proposition 65 Warning
Battery posts, terminals, and related accessories contain lead and lead compounds, chemicals known to the State of California to cause cancer and reproductive harm.
Wash hands after handling.

Jump Starting the Machine

If the machine needs to be jump started, the alternate positive post (located under the seat on the starter solenoid) can be used instead of the positive battery post (Figure 29).

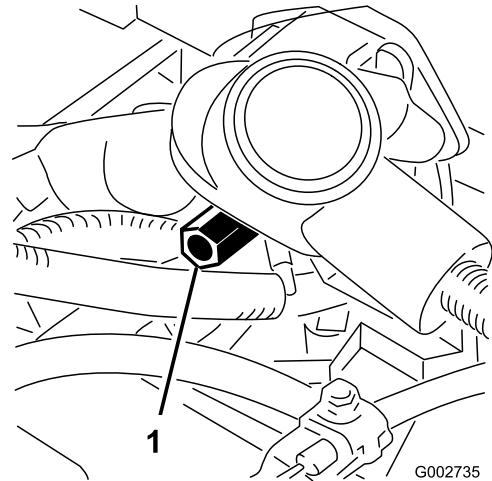

Figure 29

1. Alternate positive battery post

Replacing Fuses

The fuse block (Figure 30) is located under the seat.

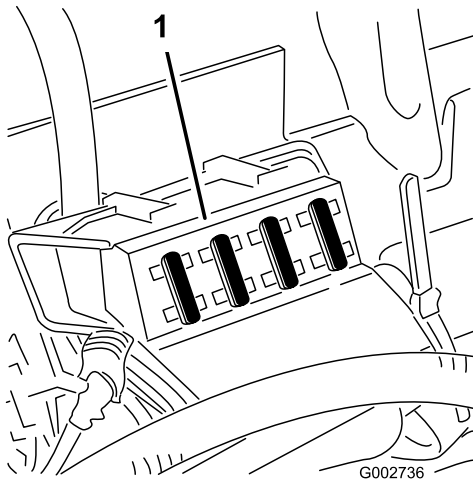

Figure 30

1. Fuse block

Caring for the Battery

Service Interval: Every 25 hours

The battery electrolyte level must be properly maintained and the top of the battery kept clean. If the machine is stored in a location where temperatures are extremely high, the battery will run down more rapidly than if the machine is stored in a location where temperatures are cool.



Battery electrolyte contains sulfuric acid which is a deadly poison and causes severe burns.

- **Do not drink electrolyte and avoid contact with skin, eyes or clothing. Wear safety glasses to shield your eyes and rubber gloves to protect your hands.**
- **Fill the battery where clean water is always available for flushing the skin.**

Keep the top of the battery clean by washing it periodically with a brush dipped in ammonia or bicarbonate of soda solution. Flush the top surface with water after cleaning. Do not remove the fill cap while cleaning.

The battery cables must be tight on the terminals to provide good electrical contact.



Incorrect battery cable routing could damage the machine and cables causing sparks. Sparks can cause the battery gasses to explode, resulting in personal injury.

- **Always disconnect the negative (black) battery cable before disconnecting the positive (red) cable.**
- **Always connect the positive (red) battery cable before connecting the negative (black) cable.**

If corrosion occurs at the battery terminals, disconnect the cables, negative (-) cable first, and scrape the clamps and terminals separately. Reconnect the cables, positive (+) cable first, and coat the terminals with petroleum jelly.

- Check the electrolyte level every 25 operating hours or, if the machine is in storage, every 30 days.
- Maintain the cell level with distilled or demineralized water. Do not fill the cells above the fill line.

Drive System Maintenance

Adjusting the Traction Drive for Neutral

If the machine moves when the traction pedal is in the neutral position, the traction cam must be adjusted.

1. Park the machine on a level surface and turn the engine off.
2. Remove the 2 screws securing the center shroud to the machine and remove the shroud (Figure 31).

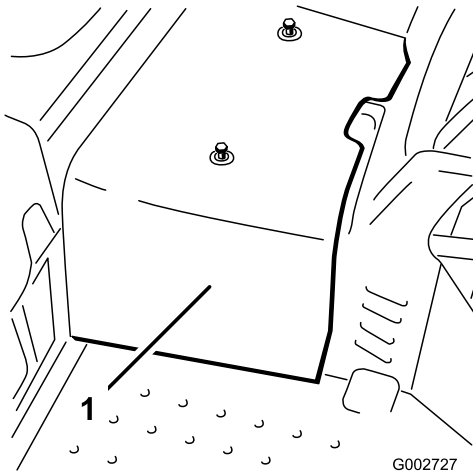

Figure 31

1. Center shroud

3. Raise the front wheel and one rear wheel off of the floor and place support blocks under the frame.



The front wheel *and* one rear wheel must be raised off the ground or the machine will move during the adjustment. Make sure the machine is supported so it will not accidentally fall injuring anyone under the machine.

4. Loosen the locknut on the traction adjustment cam (Figure 32).

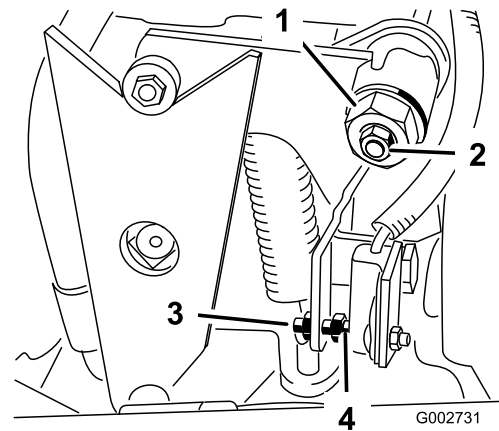

Figure 32

- | | |
|----------------------------|----------|
| 1. Traction adjustment cam | 3. Screw |
| 2. Locknut | 4. Gap |

The engine must be running so that the final adjustment of the traction adjustment cam can be performed. Contact with moving parts or hot surfaces may cause personal injury.

Keep hands, feet, face, and other body parts away from rotating parts, the muffler, and other hot surfaces.

5. Start the engine and rotate the cam hex (Figure 32) in both directions to determine the mid position of the neutral span.
6. Tighten the locknut securing the adjustment.
7. Stop the engine.
8. Install the center shroud.
9. Remove the jack stands and lower the machine to the shop floor. Test drive the machine to make sure that it does not move when the traction pedal is in neutral.

Adjusting the Traction Interlock Switch

1. Adjust the transmission for neutral; refer to Adjusting the Traction Drive for Neutral.
2. Activate the pump lever to ensure that all parts are operating freely and seated properly.
3. Adjust the screw until the air gap is .060 inches \pm .030 (Figure 32).
4. Check for proper operation.

Adjusting the Transport Speed

Obtaining Maximum Transport Speed

The traction pedal is adjusted for maximum transport speed and reverse at the factory, but an adjustment may be required if the pedal reaches full stroke before the pump lever reaches full stroke, or if a decrease in transport speed is desired.

To obtain maximum transport speed, press down on the traction pedal. If the pedal contacts the stop (Figure 33) before the pump lever reaches full stroke, an adjustment is required:

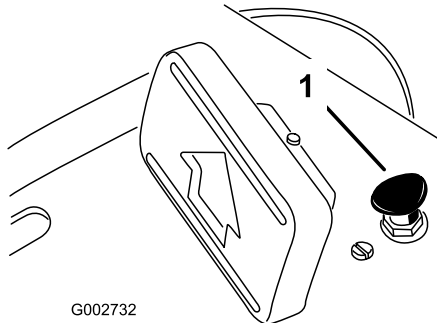

Figure 33

1. Pedal stop

1. Park the machine on a level surface, turn the engine off, and engage the parking brake.
2. Loosen the nut securing the pedal stop.
3. Tighten the pedal stop until it does not contact the traction pedal.
4. Continue applying a light load on the transport pedal and adjust the pedal so it just contacts or a gap of .100 is attained between the pedal rod and the stop. Tighten the nuts.

Reducing the Transport Speed.

1. Park the machine on a level surface, turn the engine off, and engage the parking brake.
2. Loosen the nut securing the pedal stop.
3. Tighten the pedal stop until it does not contact the traction pedal.

Controls System Maintenance

Adjusting the Lift Lever

The lift lever detent plate (Figure 35) can be adjusted if the attachment does not float properly (follow ground contour) during operation.

1. Park the machine on a level surface, turn the engine off, set the parking brake and block wheels.
2. Remove the (4) screws securing the control panel to the frame (Figure 34).

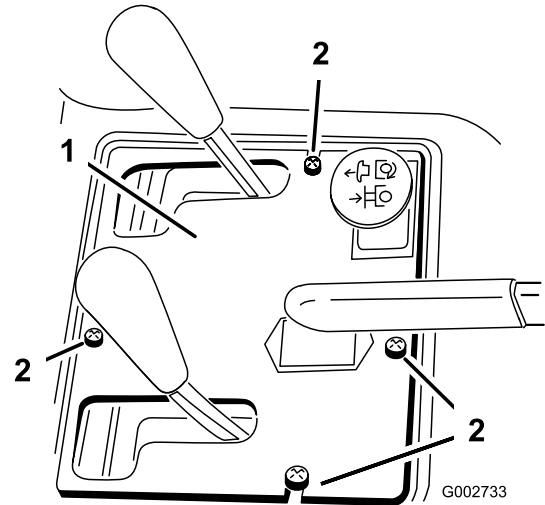

Figure 34

1. Control panel
2. Screws

3. Loosen (2) bolts securing lift lever detent plate to fender and frame.

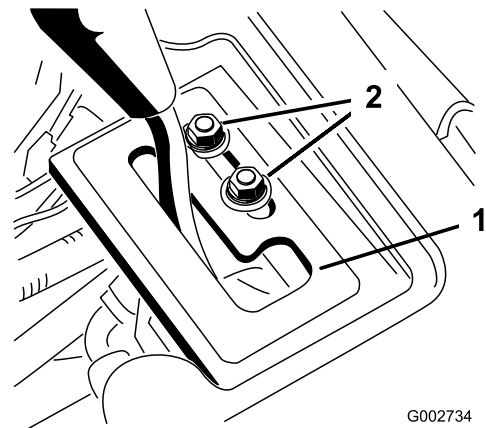

Figure 35

1. Lift lever detent plate
2. Mounting bolts



The engine must be running so that the final adjustment of the lift lever detent plate can be performed. Contact with moving parts or hot surfaces may cause personal injury.

Keep hands, feet, face, and other body parts away from rotating parts, the muffler, and other hot surfaces.

4. Start traction unit engine.
5. With the engine running and lift lever in the Float position, slide the detent plate until the lift cylinder can be extended and retracted by hand.
6. Tighten both lift lever detent plate mounting screws to secure adjustment.

Adjusting the Engine Controls

Adjusting the Throttle Control

Proper throttle operation is dependent upon proper adjustment of the throttle control. Before adjusting the carburetor, ensure that the throttle control is operating properly.

1. Pivot the seat upward.
2. Loosen the cable clamp screw securing the cable to the engine (Figure 36).

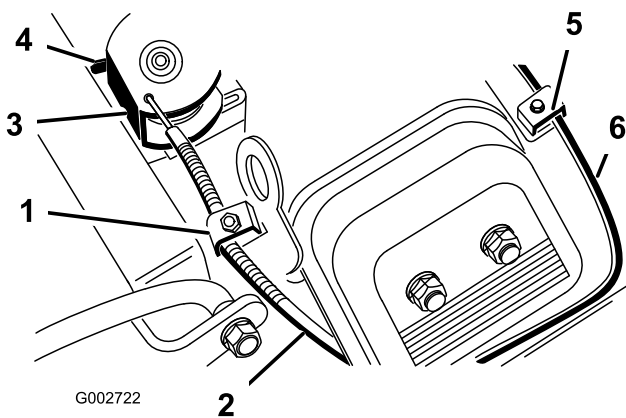

Figure 36

- | | |
|--------------------------------|-----------------------------|
| 1. Throttle casing clamp screw | 4. Stop |
| 2. Throttle cable | 5. Choke casing clamp screw |
| 3. Swivel | 6. Choke cable |

3. Move the remote throttle control lever forward to the Fast position.

4. Pull firmly on the throttle cable until the back of the swivel contacts the stop (Figure 36).
5. Tighten the cable clamp screw and check the engine speedsettings:
 - High Idle: 3400 \pm 50
 - Low Idle: 1750 \pm 100

Adjusting the Choke Control

1. Pivot the seat upward.
2. Loosen the cable clamp screw securing the cable to the engine (Figure 36).
3. Move the remote choke control lever forward to the Closed position.
4. Pull firmly on the choke cable (Figure 36) until the choke butterfly is completely closed; then tighten the cable clamp screw.

Adjust the Engine Governor Speed Control

Important: Before the engine governor speed control is adjusted, the throttle and choke controls must be adjusted properly.



The engine must be running during adjustment of the engine governor speed control. Contact with moving parts or hot surfaces may cause personal injury.

- Ensure traction pedal is in neutral and engage the parking brake before performing this procedure.
- Keep hands, feet, clothing, and other body parts away from any rotating parts, the muffler, and other hot surfaces.

Note: To adjust the low idle, use all the following steps. If only the high idle is to be adjusted, proceed directly to step 5.

1. Start the engine and let it run at half throttle for approximately five minutes to warm up.
2. Move the throttle control to the Slow setting. Adjust the idle stop screw counterclockwise until it no longer contacts the throttle lever.
3. Bend the governed idle spring anchor tang (Figure 37) to attain an idle speed of 1725 \pm 50 RPM. Check the speed with a tachometer.

Hydraulic System Maintenance

Changing the Hydraulic System Oil and Filter

Service Interval: After the first 8 hours
Every 400 hours

The hydraulic system filter must be changed initially after the first 8 hours of operation, and thereafter every 400 hours of operation or yearly, whichever occurs first. Use a genuine Toro oil filter for replacement. The hydraulic oil must be changed every 400 hours of operation or yearly, whichever occurs first.

1. Park the machine on a level surface and turn the engine off.
2. Remove the 2 screws securing the center shroud to the machine and remove the shroud (Figure 38).

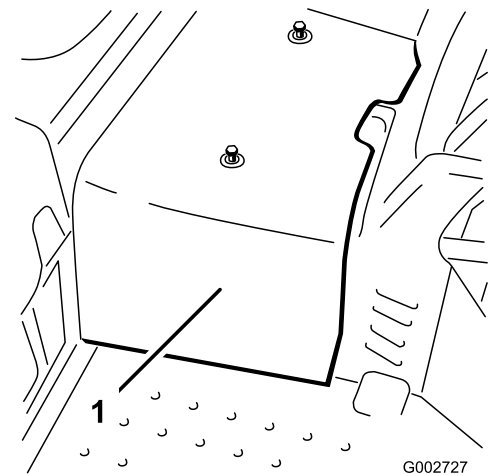

Figure 38

1. Center shroud

3. Place a drain pan under the hydraulic oil filter which is located on the left side of the machine (Figure 39).

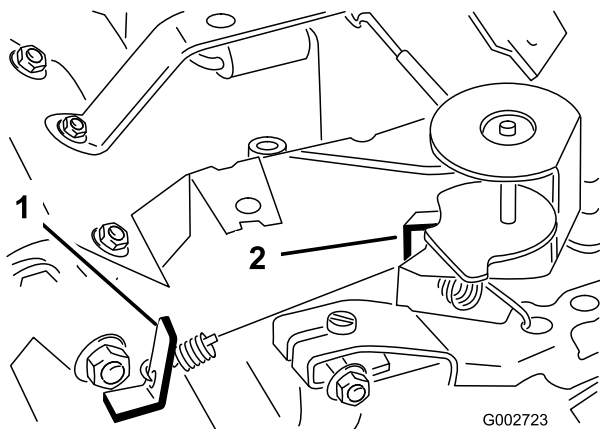

Figure 37

Shown with Carb Adapter Removed

1. Governed idle spring anchor tag
 2. High speed spring anchor tag
-
4. Adjust the idle stop screw until the idle speed is increased 25 to 50 RPM over the idle speed set in step 3. Final idle speed must be 1750 ± 100 RPM.
 5. Move the throttle control to the Fast position. Bend the high speed spring anchor tang (Figure 37) to attain a high speed of 3400 ± 50 RPM.

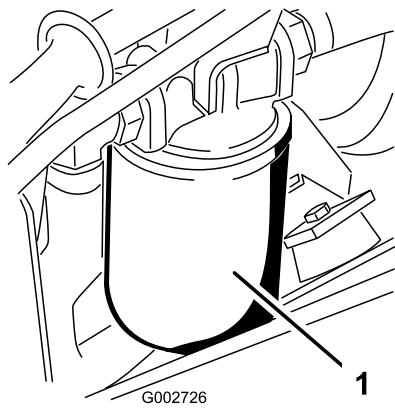

Figure 39

1. Hydraulic filter

4. Clean the area around the filter mounting area. Place a drain pan under filter. Slowly loosen, but do not remove, the hydraulic filter until oil flows past the gasket and drips down the side of the filter.

Note: If the machine is equipped with a remote hydraulics kit, the suction hose can be removed from the pump to drain the hydraulic oil.

5. Remove the filter when the oil flow slows.
6. Lubricate the sealing gasket on replacement filter with hydraulic fluid and hand turn it on until the gasket contacts filter head. Then tighten 3/4 turn further. Filter should now be sealed.
7. Fill hydraulic tank with hydraulic oil until level is up to the necked down area of the dipstick. **Do not overfill.** Refer to Checking the Hydraulic System in Operation , page 17.
8. Start and run the engine. Operate the lift cylinder until it extends and retracts and forward and reverse wheel motion is achieved.
9. Stop the engine and check the oil level in reservoir, add oil if necessary.
10. Check all connections for leaks.
11. Install the center shroud.
12. Dispose of oil properly.

Checking the Hydraulic Lines and Hoses

Service Interval: Before each use or daily

Check the hydraulic lines and hoses daily for leaks, kinked lines, loose mounting supports, wear, loose fittings, weather deterioration, and chemical deterioration. Make all necessary repairs before operating.



Hydraulic fluid escaping under pressure can penetrate skin and cause injury.

- Make sure all hydraulic fluid hoses and lines are in good condition and all hydraulic connections and fittings are tight before applying pressure to the hydraulic system.
- Keep your body and hands away from pin hole leaks or nozzles that eject high pressure hydraulic fluid.
- Use cardboard or paper to find hydraulic leaks.
- Safely relieve all pressure in the hydraulic system before performing any work on the hydraulic system.
- Seek immediate medical attention if fluid is injected into skin.

Charging the Hydraulic System

Whenever a hydraulic component is repaired or replaced, the hydraulic oil filter should be changed and the hydraulic system charged.

Make sure that the hydraulic reservoir and filter are filled with oil at all times when charging the hydraulic system.

1. Park the machine on a level surface and turn the engine off.
2. Remove the 2 screws securing the center shroud to the machine and remove the shroud (Figure 40).

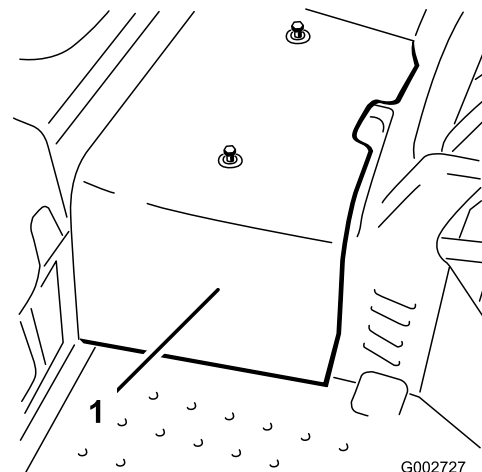

Figure 40

1. Center shroud

3. Raise the front wheel and one of the rear wheels off of the floor and place support blocks under the frame.



The front wheel *and* one rear wheel must be raised off the ground or the machine will move during the adjustment. Make sure the machine is supported so it will not accidentally fall injuring anyone under the machine.

4. Start the engine and set the throttle to allow the engine to run at approximately 1800 RPM. Allow the engine to idle for at least 1 minute.
5. Actuate the lift valve lever until the lift cylinder rod moves in and out several times. If the cylinder rod does not move after 10-15 seconds or the pump emits abnormal sounds, shut the engine off immediately and determine the cause or problem. Inspect for the following:
 - Loose filter or suction lines
 - Loose or faulty coupler on the pump
 - Blocked suction line
 - Faulty charge relief valve
 - Faulty charge pump

If the cylinder moves in 10-15 seconds, proceed to step 3.

Note: A hydrostatic transmission service manual (Bulletin No. 9646) and a repair manual (Bulletin No. 9659) can be obtained from:

Sundstrand Corporation
2800 East 13th Street
Ames, Iowa 50010

6. Operate the traction pedal in forward and reverse. The wheels that are off of the floor should rotate in the proper direction.
 - If the wheels rotate in the wrong direction, stop the engine, remove the lines from the rear of the pump and reverse the locations.
 - If the wheels rotate in the proper direction, stop the engine and adjust the spring adjusting pin locknut (Figure 41). Adjust the traction neutral position; refer to Adjusting the Traction Drive for Neutral.

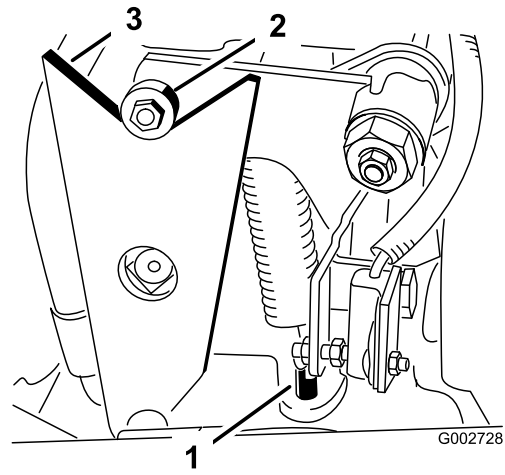

Figure 41

1. Spring adjusting pin
 2. Bearing
 3. Cam
-
7. Check the adjustment of the traction interlock switch; refer to Adjusting the Traction Interlock Switch.
 8. Install the center shroud.

Cleaning

Inspecting and Cleaning the Machine

Service Interval: Before each use or daily

At the completion of operation, thoroughly wash the machine with a garden hose-without a nozzle-so that excessive water pressure will not cause contamination and damage to the seals and bearings.

Make sure that the cooling fins and area around the engine cooling air intake are kept free of debris. After cleaning, inspect the machine for possible hydraulic fluid leaks, damage, or wear to hydraulic and mechanical components.

Storage

Traction Unit

1. Thoroughly clean the traction unit, attachments and the engine.
2. Check the tire pressure. Inflate all traction unit tires to 4-6 psi.
3. Check all fasteners for looseness; tighten as necessary.
4. Grease or oil all grease fittings and pivot points. Wipe off any excess lubricant.
5. Lightly sand and use touch up paint on painted areas that are scratched, chipped or rusted.
6. Service the battery and cables as follows:
 - A. Remove the battery terminals from the battery posts.
 - B. Clean the battery, terminals and posts with a wire brush and baking soda solution.
 - C. Coat the cable terminals and battery posts with Grafo 112X skin-over grease (Toro Part No. 505-47), or petroleum jelly to prevent corrosion.
 - D. Slowly recharge the battery for 24 hours every 60 days to prevent lead sulfation of the battery.

Note: The specific gravity of a fully charged battery is 1.250.

Note: Store the battery in a cool atmosphere to avoid quick deterioration of the charge in the battery. To prevent the battery from freezing, make sure that it is fully charged.

Engine

1. Change the engine oil and filter. Refer to Changing the Engine Oil and Filter.
2. Start the engine and run it at idle speed for two minutes.
3. Thoroughly clean and service the air cleaner assembly. Refer to Servicing the Air Cleaner.
4. Seal the air cleaner inlet and the exhaust outlet with weather proof masking tape.
5. Check the oil filler cap and fuel tank cap to ensure they are securely in place.

Schematics

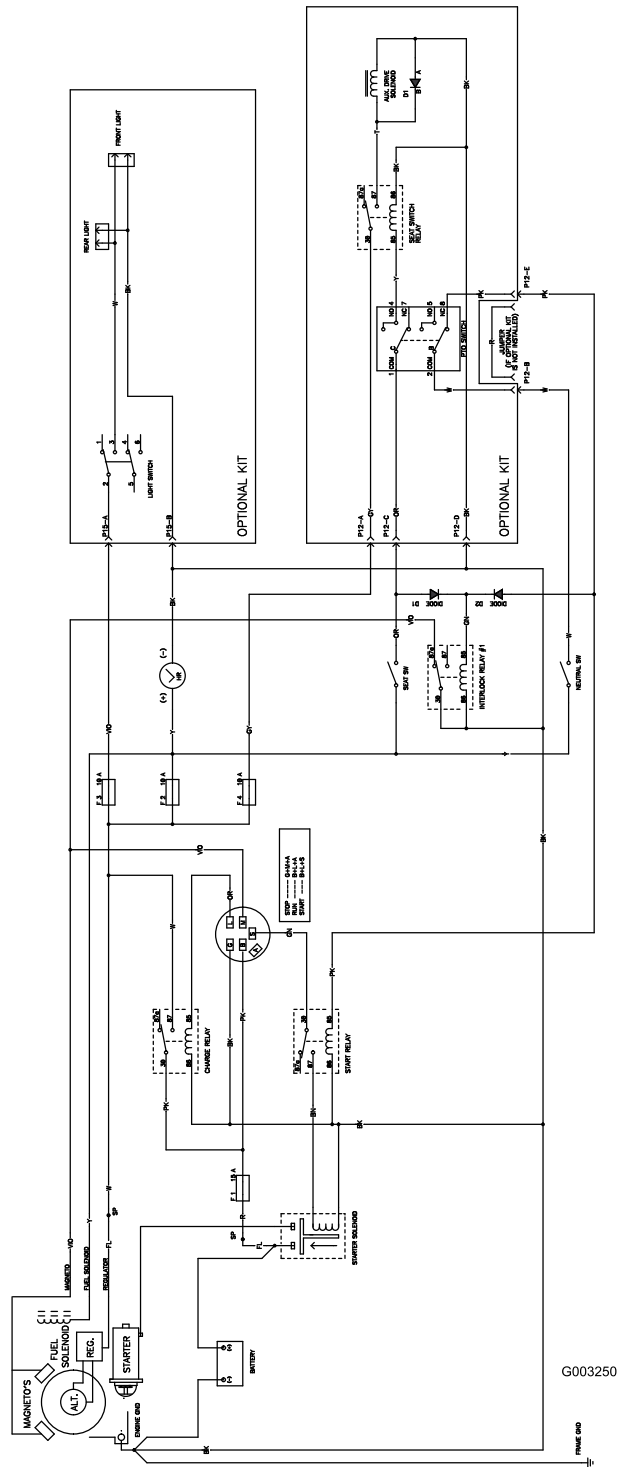

Electrical Schematic (Rev. B)

G003250

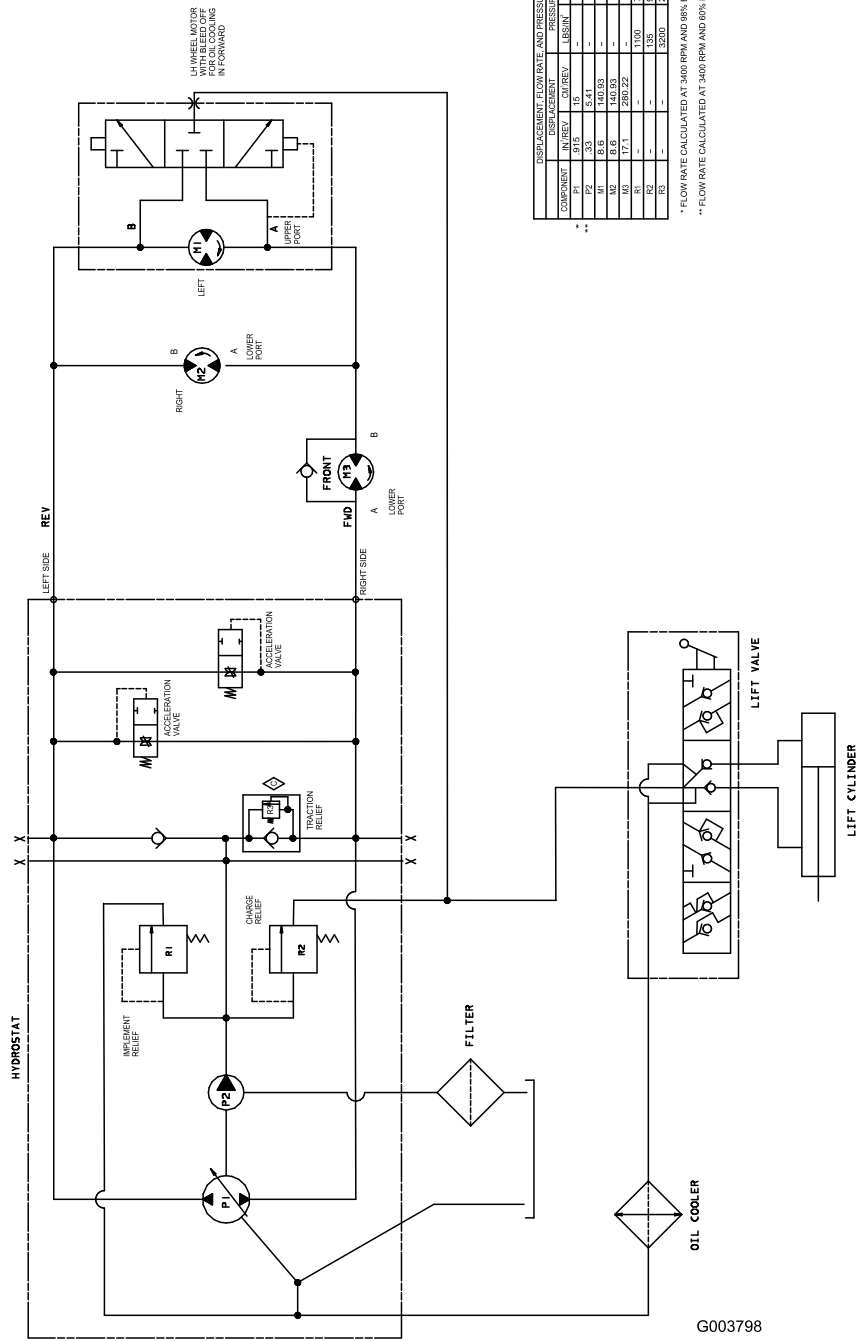

Hydraulic Schematic—Model 08703 (Rev. C)

COMPONENT	DISPLACEMENT		FLOW RATE		PRESSURE		FLOW RATE
	IN/REV	CM/REV	CM ³ /REV	GPM/REV	LB/IN ²	BAR	
P1	2.3	140.0	140.0	11.0	—	—	11.0
P2	8.41	505.0	505.0	39.0	—	—	39.0
M1	8.6	505.0	505.0	39.0	—	—	39.0
M2	8.6	505.0	505.0	39.0	—	—	39.0
R1	12.1	727.2	727.2	56.0	1100	75.8	—
R2	—	—	—	—	135	9.3	—
RS	—	—	—	—	3200	220.7	—

* FLOW RATE CALCULATED AT 3400 RPM AND 98% EFFICIENCY.

** FLOW RATE CALCULATED AT 3400 RPM AND 86% EFFICIENCY.

G003798

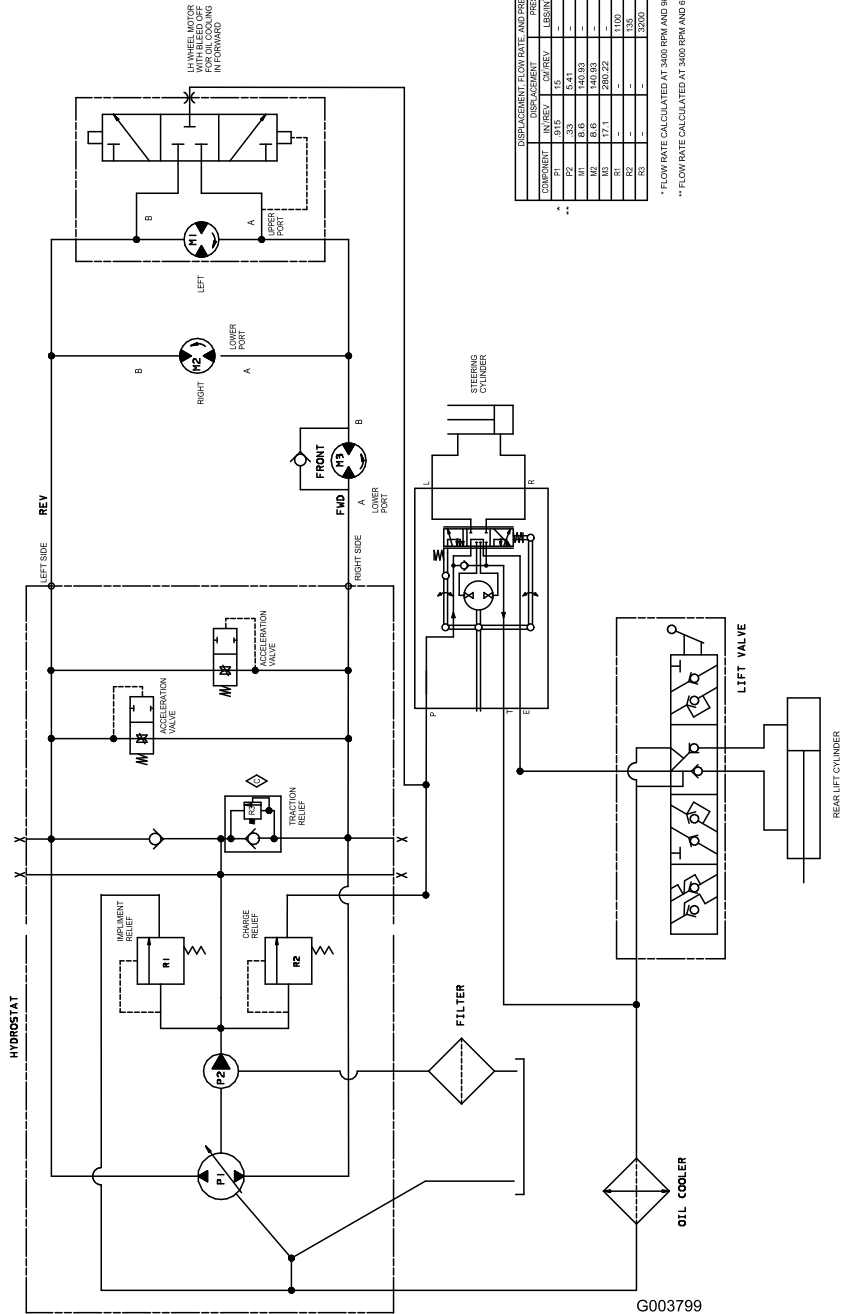

Hydraulic Schematic—Model 08705 (Rev. C)

COMPONENT	DISPLACEMENT		FLOW RATE		PRESSURE		FLOW RATE	
	IN/REV	CM/REV	GPM	LPM	BAR	PSI	GPM	LPM
P1	37.5	5.41	—	—	—	—	33.2	50.0
M1	8.8	1.40	—	—	—	—	—	—
M2	8.8	1.40	—	—	—	—	—	—
R1	17.1	2.80	—	—	—	—	—	—
R2	—	—	1.00	1.50	100	14.5	—	—
R3	—	—	135	202.7	—	—	—	—

* FLOW RATE CALCULATED AT 3400 RPM AND 80% EFFICIENCY.
 ** FLOW RATE CALCULATED AT 3400 RPM AND 60% EFFICIENCY.



Toro General Commercial Products Warranty

A Two-Year Limited Warranty

Conditions and Products Covered

The Toro Company and its affiliate, Toro Warranty Company, pursuant to an agreement between them, jointly warrant your Toro Commercial Product ("Product") to be free from defects in materials or workmanship for two years or 1500 operational hours*, whichever occurs first. This warranty is applicable to all products with the exception of Aerators (refer to separate warranty statements for these products). Where a warrantable condition exists, we will repair the Product at no cost to you including diagnosis, labor, parts, and transportation. This warranty begins on the date the Product is delivered to the original retail purchaser.

* Product equipped with hour meter

Instructions for Obtaining Warranty Service

You are responsible for notifying the Commercial Products Distributor or Authorized Commercial Products Dealer from whom you purchased the Product as soon as you believe a warrantable condition exists. If you need help locating a Commercial Products Distributor or Authorized Dealer, or if you have questions regarding your warranty rights or responsibilities, you may contact us at:

Toro Commercial Products Service Department
Toro Warranty Company
8111 Lyndale Avenue South
Bloomington, MN 55420-1196
952-888-8801
E-mail: commercial.warranty@toro.com

Owner Responsibilities

As the Product owner, you are responsible for required maintenance and adjustments stated in your *Operator's Manual*. Failure to perform required maintenance and adjustments can be grounds for disallowing a warranty claim.

Items and Conditions Not Covered

Not all product failures or malfunctions that occur during the warranty period are defects in materials or workmanship. This warranty does not cover the following:

- Product failures which result from the use of non-Toro replacement parts, or from installation and use of add-on, or modified non-Toro branded accessories and products. A separate warranty may be provided by the manufacturer of these items.
- Product failures which result from failure to perform recommended maintenance and/or adjustments. Failure to properly maintain your Toro product per the Recommended Maintenance listed in the *Operator's Manual* can result in claims for warranty being denied.
- Product failures which result from operating the Product in an abusive, negligent or reckless manner.
- Parts subject to consumption through use unless found to be defective. Examples of parts which are consumed, or used up, during normal Product operation include, but are not limited to, brakes pads and linings, clutch linings, blades, reels, bed knives, tines, spark plugs, castor wheels, tires, filters, belts, and certain sprayer components such as diaphragms, nozzles, and check valves, etc.
- Failures caused by outside influence. Items considered to be outside influence include, but are not limited to, weather, storage practices, contamination, use of unapproved coolants,

lubricants, additives, fertilizers, water, or chemicals, etc.

- Normal noise, vibration, wear and tear, and deterioration.
- Normal "wear and tear" includes, but is not limited to, damage to seats due to wear or abrasion, worn painted surfaces, scratched decals or windows, etc.

Parts

Parts scheduled for replacement as required maintenance are warranted for the period of time up to the scheduled replacement time for that part. Parts replaced under this warranty are covered for the duration of the original product warranty and become the property of Toro. Toro will make the final decision whether to repair any existing part or assembly or replace it. Toro may use remanufactured parts for warranty repairs.

Note Regarding Deep Cycle Battery Warranty:

Deep cycle batteries have a specified total number of kilowatt-hours they can deliver during their lifetime. Operating, recharging, and maintenance techniques can extend or reduce total battery life. As the batteries in this product are consumed, the amount of useful work between charging intervals will slowly decrease until the battery is completely worn out. Replacement of worn out batteries, due to normal consumption, is the responsibility of the product owner. Battery replacement may be required during the normal product warranty period at owner's expense.

Maintenance is at Owner's Expense

Engine tune-up, lubrication cleaning and polishing, replacement of filters, coolant, and completing Recommended Maintenance are some of the normal services Toro products require that are at the owner's expense.

General Conditions

Repair by an Authorized Toro Distributor or Dealer is your sole remedy under this warranty.

Neither The Toro Company nor Toro Warranty Company is liable for indirect, incidental or consequential damages in connection with the use of the Toro Products covered by this warranty, including any cost or expense of providing substitute equipment or service during reasonable periods of malfunction or non-use pending completion of repairs under this warranty. Except for the Emissions warranty referenced below, if applicable, there is no other express warranty. All implied warranties of merchantability and fitness for use are limited to the duration of this express warranty.

Some states do not allow exclusions of incidental or consequential damages, or limitations on how long an implied warranty lasts, so the above exclusions and limitations may not apply to you. This warranty gives you specific legal rights, and you may also have other rights which vary from state to state.

Note regarding engine warranty:

The Emissions Control System on your Product may be covered by a separate warranty meeting requirements established by the U.S. Environmental Protection Agency (EPA) and/or the California Air Resources Board (CARB). The hour limitations set forth above do not apply to the Emissions Control System Warranty. Refer to the Engine Emission Control Warranty Statement printed in your *Operator's Manual* or contained in the engine manufacturer's documentation for details.

Countries Other than the United States or Canada

Customers who have purchased Toro products exported from the United States or Canada should contact their Toro Distributor (Dealer) to obtain guarantee policies for your country, province, or state. If for any reason you are dissatisfied with your Distributor's service or have difficulty obtaining guarantee information, contact the Toro importer.