



Workman® 3200

Model No. 07211TC - 220000001 and up.

Parts Catalog

Ordering Replacement Parts

To order replacement parts, please supply the part number, the quantity, and the description of each part desired.

Understanding Reference Numbers

Each identified part in an illustration has a reference number. The reference number for a part also appears in the parts list, along with other information about the part.

This catalog uses two special reference number formats, one to indicate parts in a service assembly and another to indicate the quantity of a given part in an illustration.

Service Assembly Reference Numbers

Parts in service assemblies have reference numbers in the form a:b. The a represents the reference number of the entire service assembly and the b represents a sequential number unique to each part within the service assembly.

For example, a wheel assembly might be identified by reference number 6, the tire by 6:1, the valve by 6:2, and the wheel by 6:3. When you order the assembly identified by reference number 6, you receive all parts identified by reference numbers 6:1, 6:2, and 6:3. However, you may also order any part individually. Reference numbers of this type appear in illustrations and in part lists.

Reference Numbers Indicating Quantity

In an illustration, if a reference number indicates more than one part, the reference number has the form nX y. The n represents the quantity of the part, the X is the multiplication symbol, and the y represents the reference number.

For example, in an illustration, the reference number 2X 37 means that two of the parts identified by reference number 37 are indicated.

Contents

Description	Page	Description	Page
Hood and Bumper Assembly 4	Hydraulic Filter Assembly 35
Operator Frame Assembly 5	Battery Assembly 36
Dash Panel Assembly 6	Fuel Tank and Air Cleaner Assembly 37
Steering Assembly 7	Air Cleaner Assembly No. 105-7968 38
Brake and Accelerator Assembly 8	Lift Valve Linkage Assembly 39
Master Cylinder Assembly No. 94-3800 9	Differential Lock and Parking Brake Assembly 40
Hydraulic Brake Assembly 10	Remote Hydraulic Assembly 41
Clutch Linkage Assembly 11	Hydraulic Valve Assembly No. 43-1710-01 42
Shroud and Seat Assembly 12	Remote Hydraulics 43
Roll-Over-Protection-System Assembly 13	Transaxle Case Assembly No. 105-4180 45
Front Wheel Assembly 14	Transaxle Gear Shaft Assembly No. 105-4180 46
RH Front Brake Assembly No. 87-3010 15	Shift Fork Assembly No. 105-4180 47
LH Front Brake Assembly No. 87-3020 16	Differential Gear Assembly No. 105-4180 48
Tie Rod Assembly 17	Countershaft Assembly Transaxle Assembly No. 105-4180 49
Center Console Assembly 18	Cylinder Assembly 50
Front Suspension Assembly 19	Crankshaft Assembly 51
Front Control Arm Assembly 20	Cylinder Head Assembly 52
Lift Valve and Cylinder Assembly 21	Manifold Assembly 53
Hydraulic Valve Assembly No. 43-1950-03 22	Carburetor Assembly 54
Hydraulic Gear Pump Assembly No. 87-5700 23	Cam Shaft Assembly 55
Rear Frame Assembly 24	Oil Pan Assembly 56
Rear Axle Assembly 25	Gear Cover Assembly 57
LH Rear Brake Assembly No. 93-7126 26	Gear Housing Assembly 58
RH Rear Brake Assembly No. 93-7125 27	Water Pump Assembly 59
Driveshaft Assembly No. 98-2918 28	Governor Assembly 60
Radiator and Hydraulic Pump Assembly 29	Alternator Assembly 61
Fan and Hydraulic Pump Drive Assembly 30	Starter Motor Assembly 62
Tail Light and Fender Assembly 31	Ignition Assembly 63
Engine Assembly 32	Gasket Assembly 64
Engine Support Assembly 33		
Transaxle Assembly 34		

Part Description Abbreviations

Part descriptions in this catalog may include the following abbreviations.

AR.	as required	INC.	incorporated
ASM.	assembly	LH.	left hand
BBC.	blade brake clutch	NI.	nylon insert
CARR.	carriage	NPTF.	national pipe thread fine
DEG.	degrees	PFH.	phillips flat head
EXT.	external	PPH.	phillips pan head
FH.	flat head	PPHTF.	phillips pan head thread forming
GA.	gauge	PRH.	phillips round head
HF.	hex flange	PTH.	phillips truss head
HH.	hex head	PTO.	power-take-off
HHF.	hex head flange	RH.	right hand
HHFTF.	hex head flange thread forming	ROPS.	roll-over-protection-system
HJ.	hex jam	SFH.	slotted fillister head
HLH.	hex lag head	SHH.	slotted hex head
HOC.	height-of-cut	SHWH.	slotted hex washer head
HSBH.	hex socket button head	SPH.	slotted pan head
HSFH.	hex socket flat head	SQH.	square head
HSH.	hex socket head	SRH.	slotted round head
HWH.	hex washer head	STD.	standard
HWHTF.	hex washer head thread forming	TAP.	self tapping
HYD.	hydraulic	TTH.	torx truss head

Footnotes

- ❶ Not serviced separately

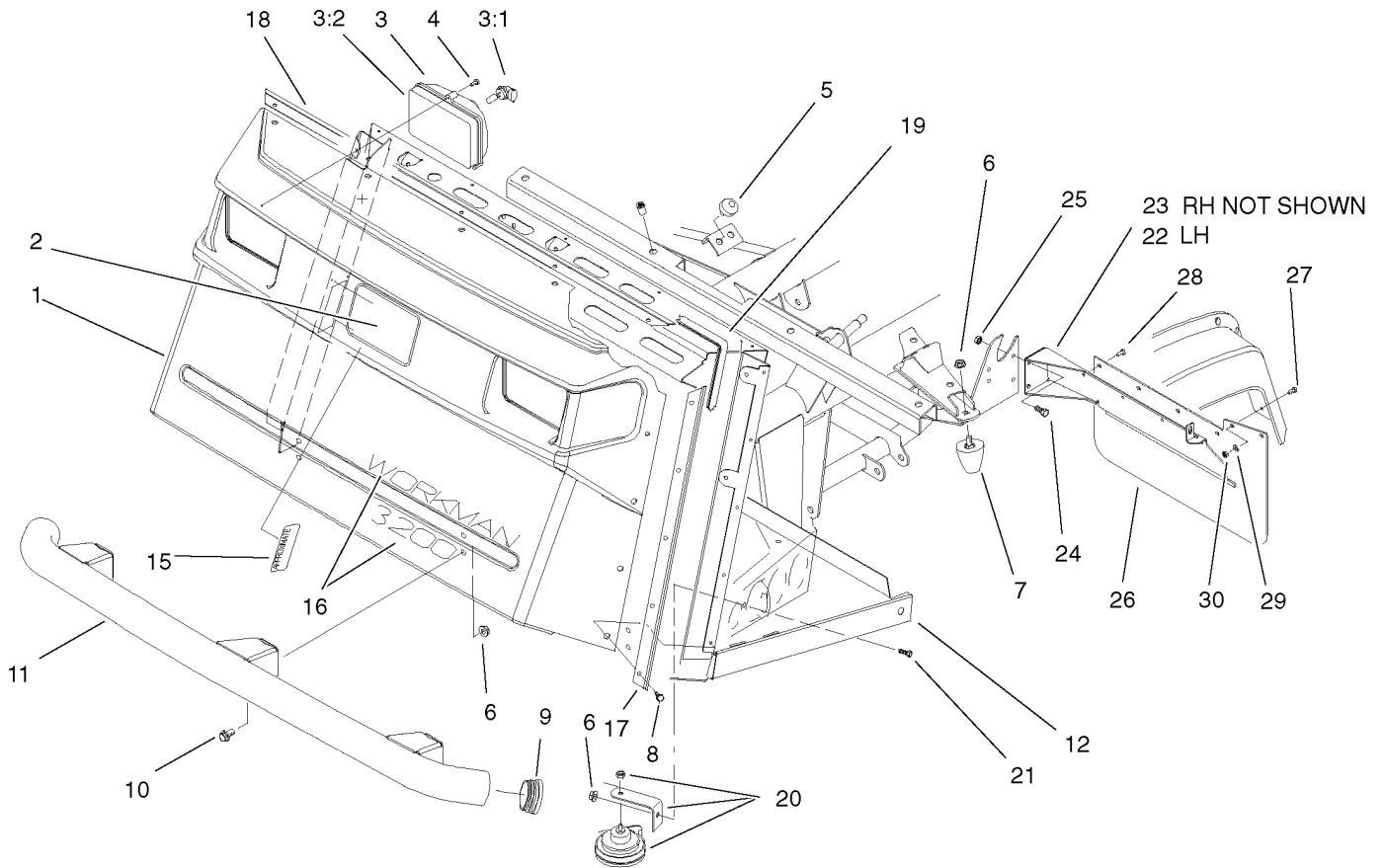

Hood and Bumper Assembly

Ref	Part No.	Qty.	Description
1	87-0710	1	Hood-Front
2	62-5550	1	Decal
3	87-2120	2	Headlight
3:1	95-0909	1	Lamp-12 Volt
3:2	87-6330	1	Lens-Headlight
4	32104-88	6	Screw-HWH
5	87-2440	2	Bumper-Rubber
6	3290-357	9	Nut-HHF, Whiz
7	26-0071	2	Snubber-Rubber
8	87-6620	15	Screw
9	2410-42	2	Cap-End
10	3234-1	6	Screw-HHF
11	87-4070-03	1	Bumper ASM
12	105-4218	1	Operator Frame ASM
15	94-1224	1	Decal-Load Rating
16	87-6700	1	Decal-Workman, 3200
17	87-8120-03	2	Bracket-Trim, Side
18	87-8130-03	1	Bracket-Trim, Top
19	87-8160	1	Trim-Lok
20	116749	1	Horn
21	323-4	1	Screw-HH
22	94-3838-03	1	Bracket-Mudflap, LH
23	94-3839-03	1	Bracket-Mudflap, RH
24	321-4	4	Screw-HH

Ref	Part No.	Qty.	Description
25	32128-33	4	Nut-HF
26	94-3841	2	Mudflap
27	3250-13	4	Screw-PPH
28	146489	8	Rivet
29	3256-61	4	Washer-Flat
30	3296-2	4	Nut-Lock

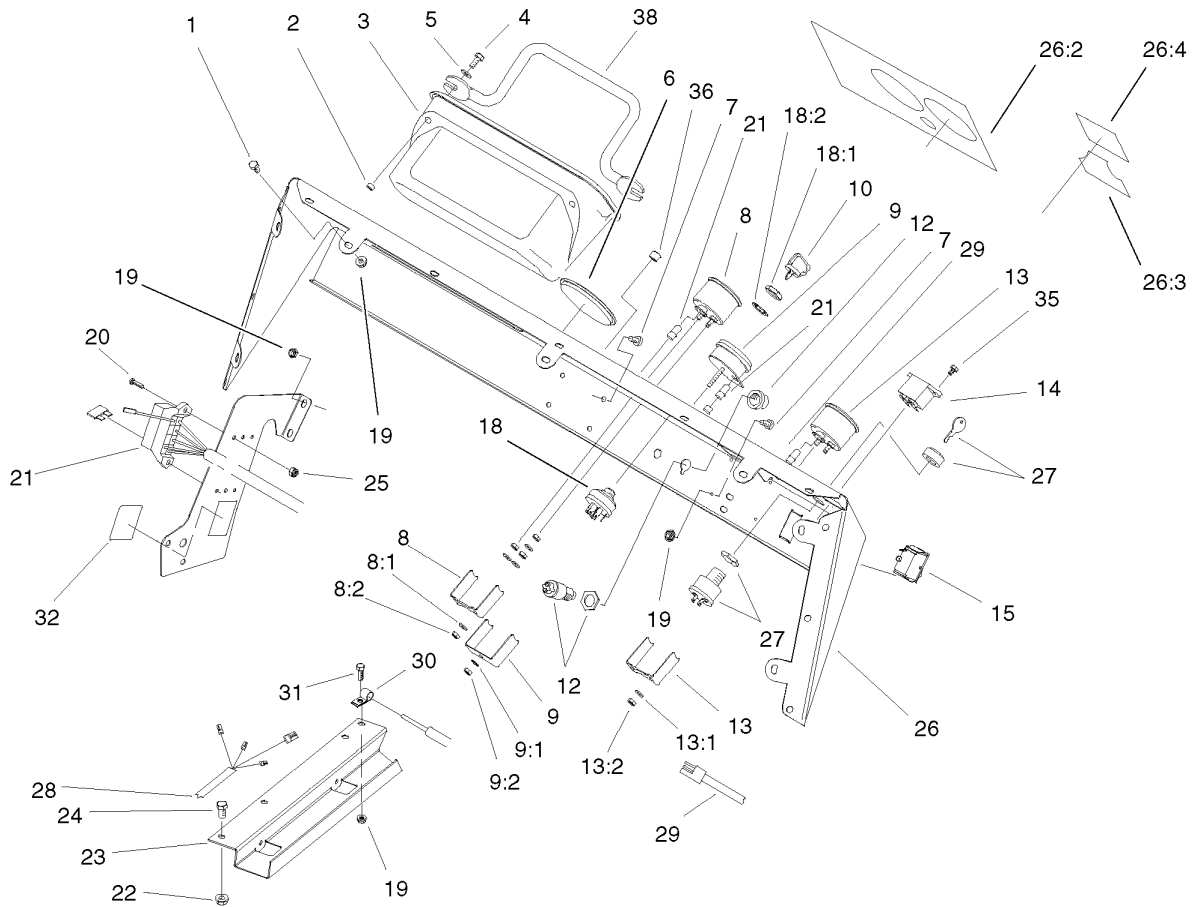

Dash Panel Assembly

Ref	Part No.	Qty.	Description
1	321-2	7	Screw-HH
2	32148-6	2	Insert-Nut
3	87-3780	1	Box-Glove
4	321-5	2	Screw-HH
5	3256-22	2	Washer-Flat
6	2410-35	1	Plug-Cap
7	3274-31	4	Screw-HSBH
8	105-2540	1	Gauge-Temp, Gas
8:1	3254-1	3	Washer-Lock, Int
8:2	3217-27	3	Nut-Hex
9	98-9306	1	Light-Warning
9:1	3254-1	1	Washer-Lock, Int
9:2	3217-27	1	Nut-Hex
10	63-8360	1	Key-Ignition
12	18-2830	1	Button-Horn
13	98-9339	1	Gauge-Fuel
13:1	3254-1	3	Washer-Lock, Int
13:2	3217-27	3	Nut-Hex
14	75-6820	1	Hourmeter
15	87-3790	1	Switch-Light
18	27-2360	1	Switch-Key
18:1	218-446	1	Nut-Hex
18:2	218-447	1	Washer-Lock
19	32128-33	12	Nut-HF

Ref	Part No.	Qty.	Description
20	3250-13	2	Screw-PPH
21	105-1792	1	Harness-Wire, Front Right
22	32128-20	3	Nut-HF
23	93-7094-03	1	Cover-Harness, Wire
24	322-2	3	Screw-HH
25	3296-2	2	Nut-Lock
26	105-4247	1	Dash Panel ASM
26:2	93-9446	1	Decal-Dash
26:3	105-7971	1	Decal-Supervisor
26:4	93-7252	1	Decal
27	94-5245	1	Switch-Key
28	105-4150	1	Harness-Wire, Rear
29	105-1791	1	Harness-Wire, Front Left
30	2412-89	1	Clamp
31	321-4	1	Screw-HH
32	93-9851	1	Decal-Fuse Block
35	32144-18	2	Screw-HH
36	2410-64	1	Plug-Button
38	105-1758	1	Handle-Grab

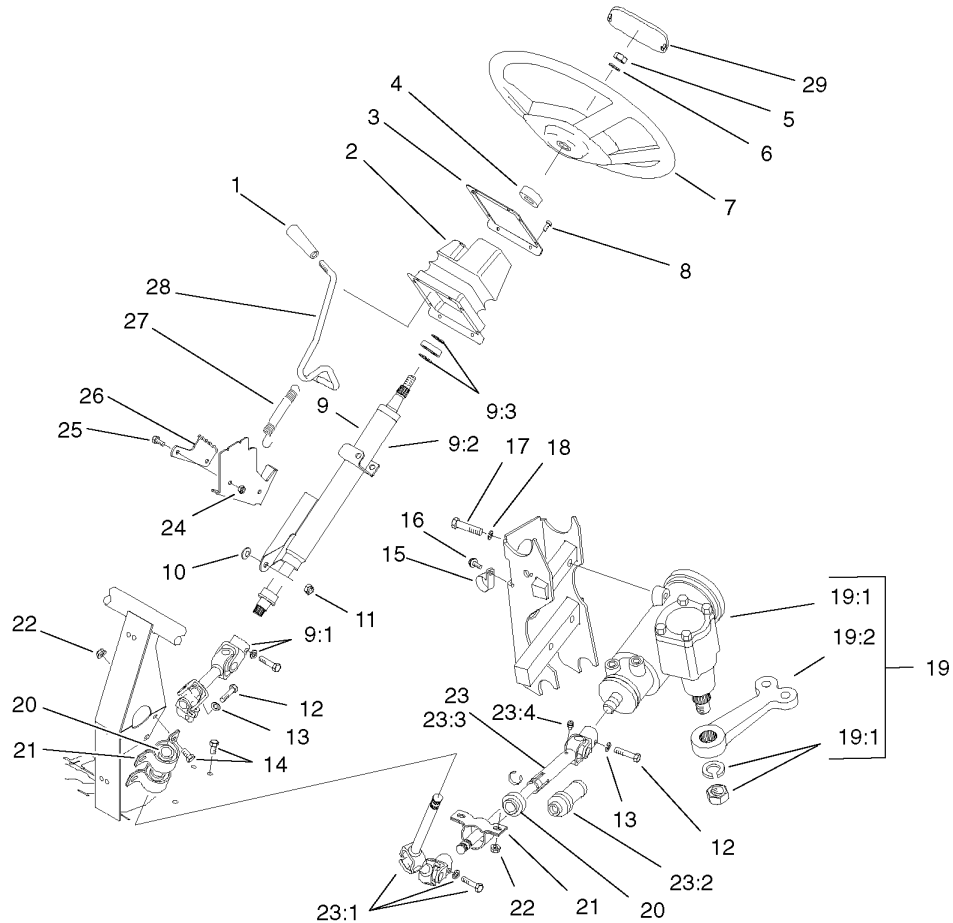

Steering Assembly

Ref	Part No.	Qty.	Description
1	233-39	1	Knob-Control
2	87-3460	1	Boot-Steering
3	87-4720-03	1	Plate-Boot, Steering
4	21-9260	1	Cover-Dust
5	3277-1	1	Nut-Hex
6	48-8070	1	Washer-Lock
7	87-3820	1	Wheel-Steering
8	32144-116	8	Tscrew-Crph
9		1	Steering Column / U-Joint
9:1	92-4154	1	U-Joint ASM
9:2	92-4153	1	Steering Column Shaft ASM
9:3	46-2210	2	Shim-Bearing, Front
10	3290-455	1	Washer-Belleville
11	3296-59	1	Nut-Lock, NI
12	48-7740	2	Screw
13	3253-4	2	Washer-Lock
14	322-2	6	Screw-HH
15	2412-105	2	Clamp-Tube, Double
16	32144-10	2	Screw-HWH
17	93-7145	3	Bolt-HH
18	87-7480	3	Washer
19		1	Steering Gear / Pitman ASM
19:1	105-9524-03	1	Gear-Steering, 2Wd
19:2	87-0370-03	1	Arm-Pitman

Ref	Part No.	Qty.	Description
20	87-2280	3	Bearing-Plastic
21	87-3250	3	Block-Pillow
22	32128-20	6	Nut-HF
23		1	Shaft-Slip, U-Joint
23:1	92-4155	1	Upper Slip Joint ASM
23:2	92-4157	1	Seal-Boot
23:3	92-4156	1	Lower Slip Joint ASM
23:4	302-5	1	Fitting-Grease
24	3296-42	2	Nut-Lock, NI
25	321-3	2	Screw-HH
26	87-3610	1	Bracket-Detent
27	65-5360	1	Extension-Spring
28	87-3130	1	Lever-Tilt
29	87-3750	1	Cover-Wheel, Steering

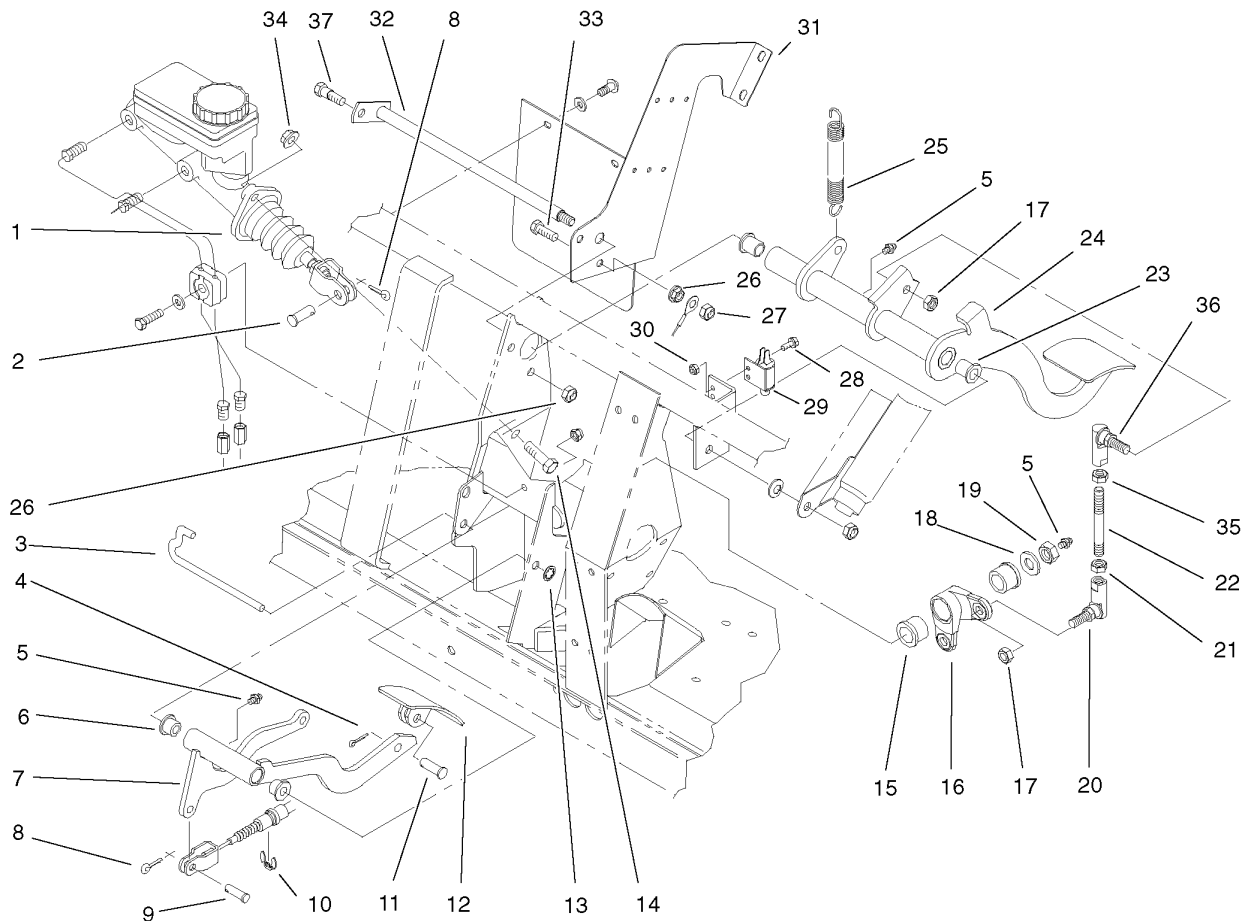

Brake and Accelerator Assembly

Ref	Part No.	Qty.	Description
1	94-3800	1	Master Cylinder ASM
2	283-2	1	Pin-Clevis
3	87-2880	1	Shaft-Pedal, Accelerator
4	3272-6	1	Pin-Cotter
5	302-5	3	Fitting-Grease
6	256-259	2	Bushing-Flange
7	93-8961-03	1	Arm-Pedal
8	3272-10	2	Pin-Cotter
9	283-30	1	Pin-Clevis
10	32120-47	1	Ring-Retaining, External
11	283-85	1	Pin-Clevis
12	93-8969-03	1	Pedal
13	32151-56	1	Ring-Retaining, External
14	323-7	2	Screw-HH
15	256-247	2	Bushing-Flange
16	94-5223	1	Crank-Bell
17	3296-6	2	Nut-Lock
18	3256-26	1	Washer-Flat
19	3296-23	1	Nut-Lock, NI
20	68-3840	1	Joint-Ball, RH Threaded
21	3220-3	1	Nut-Hex, Jam
22	94-5299	1	Rod-Link, Straight
23	256-155	2	Bushing-Flange
24	93-8965-03	1	Brake Pedal ASM

Ref	Part No.	Qty.	Description
25	76-9430-03	1	Spring-Extention
26	32128-20	2	Nut-HF
27	3296-29	1	Nut-Lock, NI
28	3290-321	2	Screw-HWH
29	55-7120	1	Switch-Brake, Parking
30	3296-2	2	Nut-Lock
31	94-3821-03	1	Plate-Center, Frame
32	95-7394	1	Brake Shaft ASM
33	322-5	1	Screw-HH
34	3290-357	2	Nut-HHF, Whiz
35	3220-16	1	Nut-Jam, LH
36	68-3841	1	Joint-Ball, LH Threaded
37	28-0540	1	Bolt-Shoulder

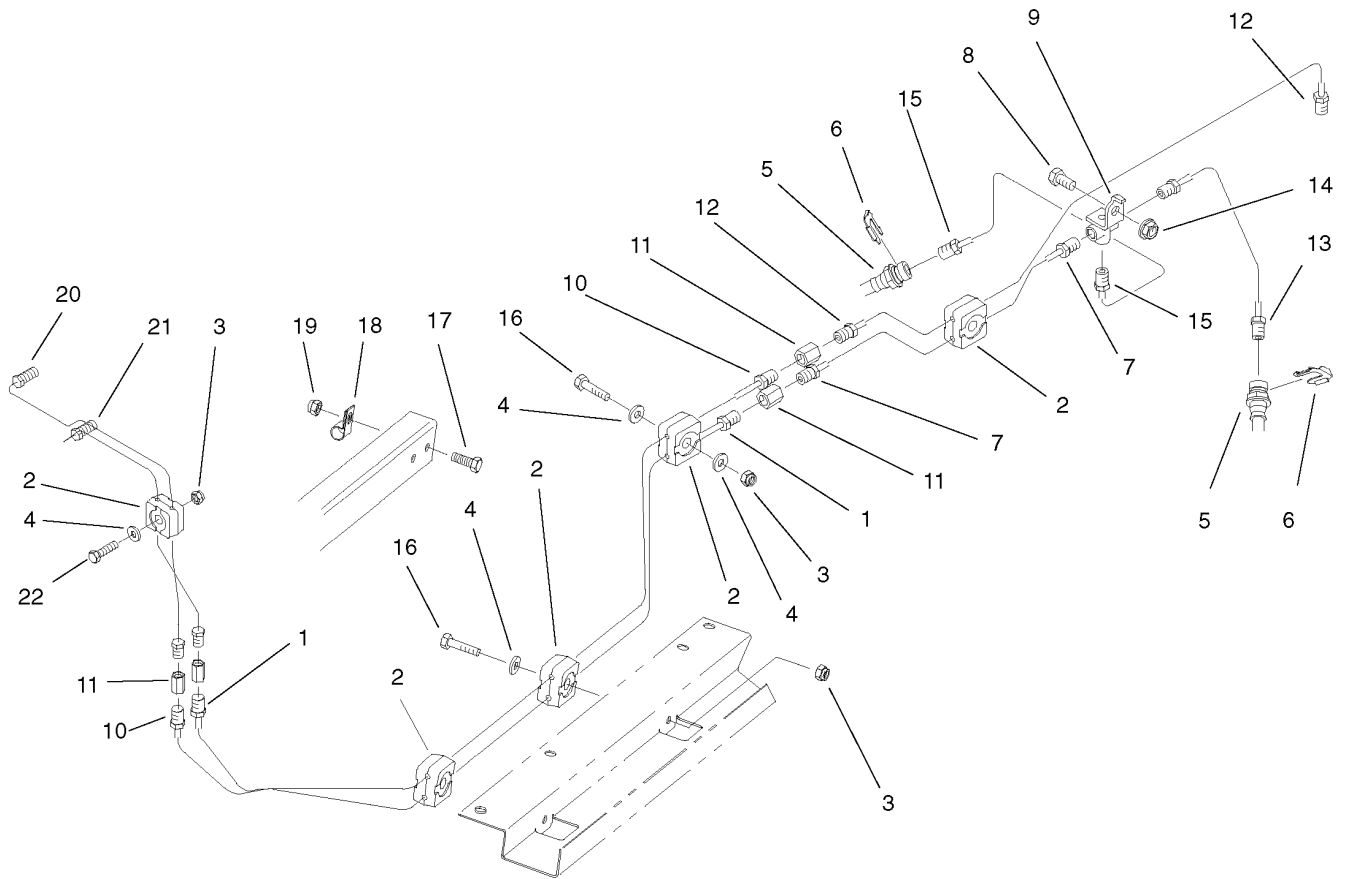

Hydraulic Brake Assembly

Ref	Part No.	Qty.	Description
1	94-3820	1	Tube-Brake, Front
2	87-7660	10	Clamp-Tube
3	3296-42	5	Nut-Lock, NI
4	3256-22	6	Washer-Flat
5	93-7123	2	Front Brake Hose ASM
6	87-3580	2	Clip-Retainer
7	93-7085	1	Front Brake Tube ASM
8	322-2	1	Screw-HH
9	87-3560	1	Tee
10	94-3819	1	Tube-Brake, Rear
11	87-3570	4	Union
12	94-3842	1	Rear Brake Tube ASM
13	93-7082	1	LH Front Brake Tube ASM
14	32128-20	1	Nut-HF
15	93-7081	1	RH Front Brake Tube ASM
16	321-9	4	Screw-HH
17	321-4	1	Screw-HH
18	2412-89	1	Clamp
19	32128-33	1	Nut-HF
20	94-3814	1	Tube-Brake, Front
21	94-3815	1	Tube-Brake, Rear
22	321-9	1	Screw-HH

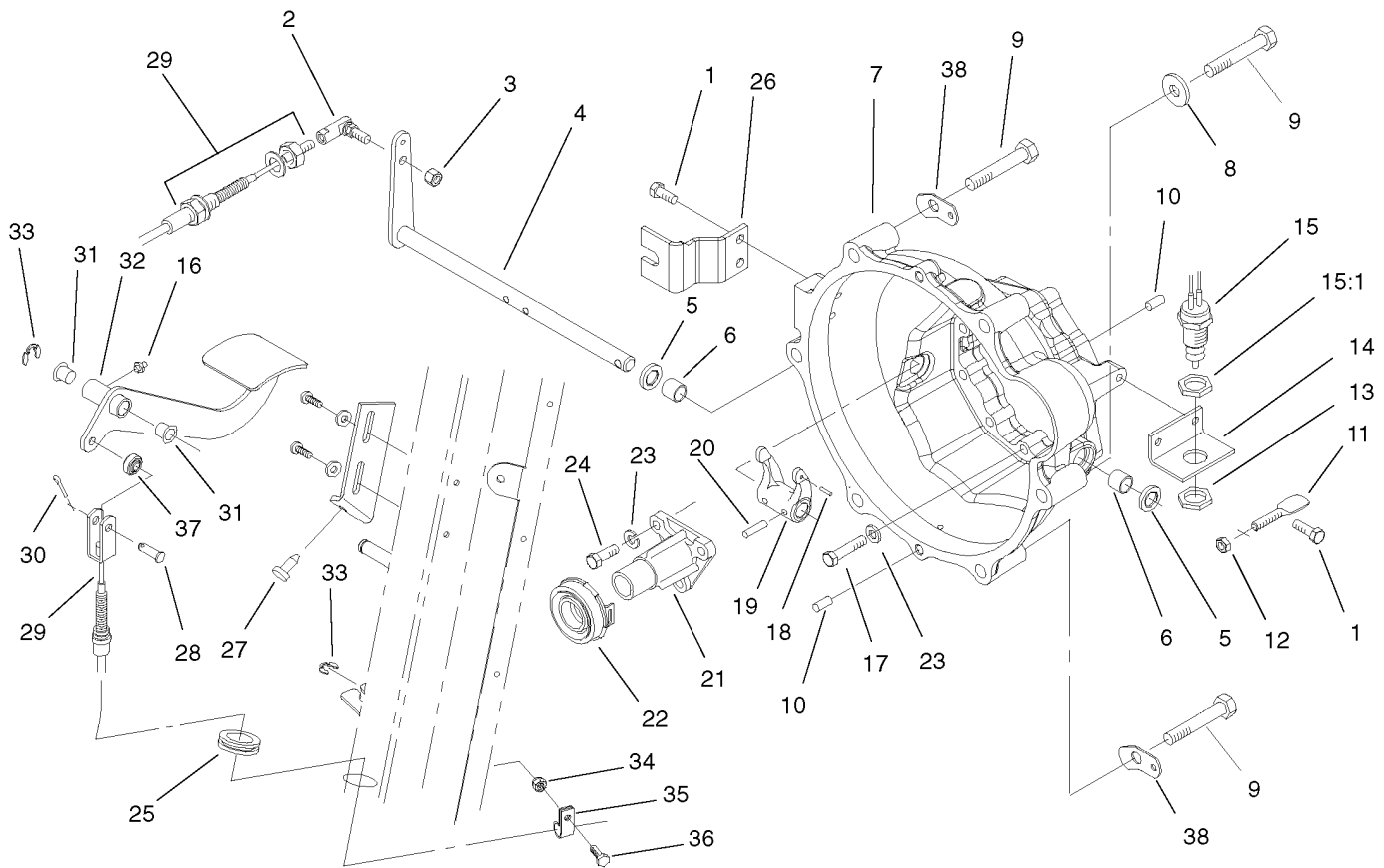

Clutch Linkage Assembly

Ref	Part No.	Qty.	Description	Ref	Part No.	Qty.	Description
1	33114-020	4	Screw-HH	24	33114-025	3	Screw-HH
2	2411-33	1	Balljoint-RH (W/Grommet)	25	240-5	1	Grommet
3	3296-4	1	Nut-Lock	26	105-1784	1	Bracket-Clutch
4	105-1702	1	Release Shaft ASM	27	87-8460	1	Bumper-Rubber
5	87-1920	2	Seal-Oil	28	283-75	1	Pin-Clevis
6	87-3770	2	Bushing-Housing, Bell	29	105-4194	1	Cable-Clutch, 2Wd
7	104-9249	1	Housing-Bell	30	3272-10	1	Pin-Cotter
8	3256-26	3	Washer-Flat	31	256-156	2	Bushing-Flange
9	3215-2	6	Screw-HH	32	99-1199-03	1	Clutch Pedal ASM
10	87-1910	4	Pin-Dowel	33	32120-47	2	Ring-Retaining, External
11	87-5360	1	Paddle-Clutch, Switch	34	32128-33	1	Nut-HF
12	3296-29	1	Nut-Lock, NI	35	2412-89	1	Clamp
13	3218-20	2	Nut-Jam	36	321-4	1	Screw-HH
14	87-5350	1	Bracket-Clutch, Switch	37	99-1202	1	Rod-End
15	87-5490	1	Switch-Clutch	38	87-6410	3	Bracket-Harness
15:1	3218-20	2	Nut-Jam				
16	302-5	1	Fitting-Grease				
17	33114-040	9	Screw-HH				
18	32121-7	1	Pin-Roll, Slotted				
19	87-5300	1	Fork-Clutch				
20	32121-24	2	Pin-Spring				
21	87-5320	1	Release-Guide				
22	87-2100	1	Bearing-Out, Throw				
23	42-9850	12	Washer-Lock, Spring				

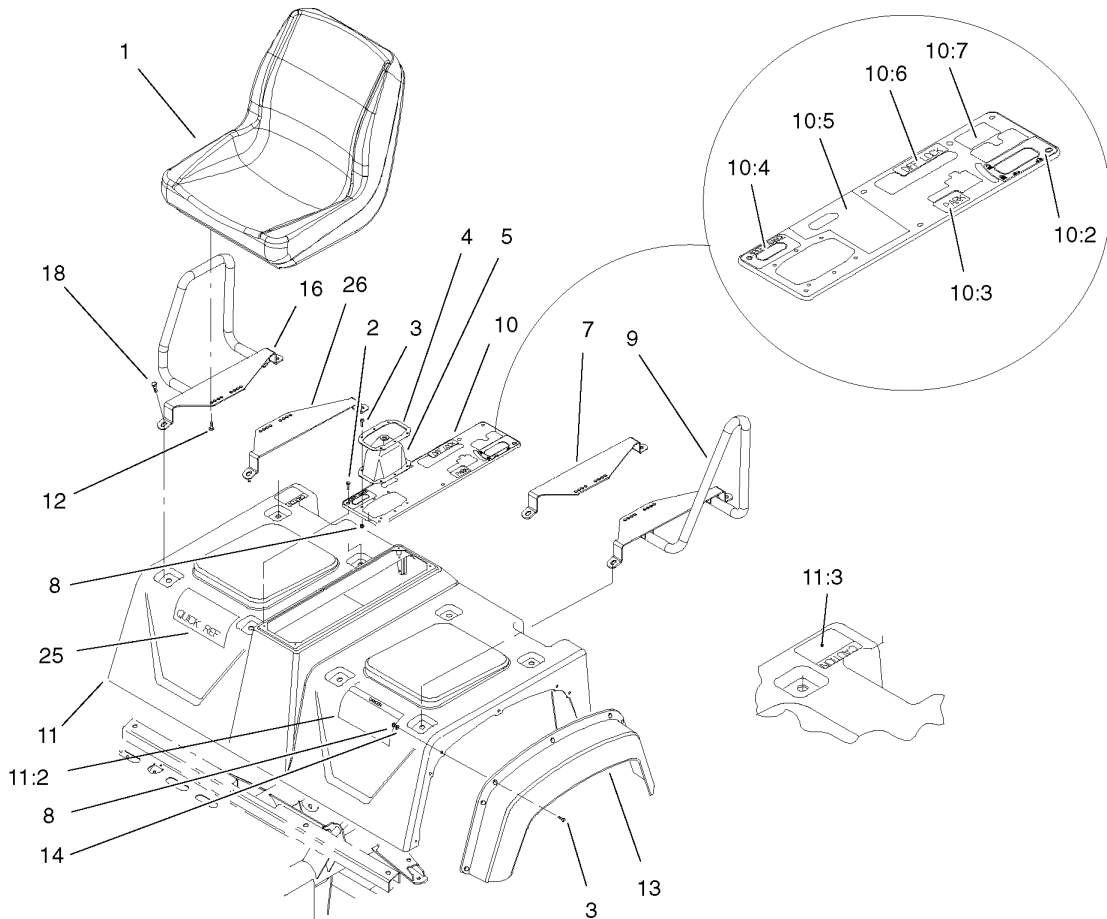

Shroud and Seat Assembly

Ref	Part No.	Qty.	Description
1	99-7281	2	Seat
2	32144-52	6	Screw-PPH
3	3250-13	20	Screw-PPH
4	87-3760-03	1	Plate-Boot, Shift
5	87-8620	1	Shift Boot ASM
7	105-1704-03	1	Strap-Seat Pad, RH
8	3296-2	20	Nut-Lock
9	105-1710	1	LH Seat Strap ASM
10	105-4244	1	Console Cover ASM
10:2	93-9444	1	Decal-Hydraulic Pump
10:3	93-9443	1	Decal-Parking Brake
10:4	93-9857	1	Decal-Axle Range
10:5	93-9861	1	Decal-PTO
10:6	93-9430	1	Decal-Differential Block
10:7	93-9866	1	Decal-Remote Hydraulics
11	105-4245	1	2Wd Front Shroud ASM
11:2	93-9860	1	Decal-Danger
11:3	93-9448	1	Decal-Fuel
12	33114-016	8	Screw-HH
13	87-9480	2	Fender-Front
14	3256-61	14	Washer-Flat
16	105-1706	1	RH Seat Strap ASM
18	3234-17	8	Screw-HHF
25	99-9352	1	Decal - Quick Ref 3200 Gr

Ref	Part No.	Qty.	Description
25	99-1216	1	Decal-Quick Reference
25	99-9350	1	Decal - Quick Ref 3200 Du
25	99-9354	1	Decal - Quick Ref 3200 Ja
25	99-9353	1	Decal - Quick Ref 3200 It
25	99-9355	1	Decal - Quick Ref 3200 Sp
25	99-9394	1	Decal - Quick Ref 3200 Da
25	99-9395	1	Decal - Quick Ref 3200 No
25	99-9396	1	Decal - Quick Ref 3200 Fi
25	99-9351	1	Decal - Quick Ref 3200 Fr
25	99-9356	1	Decal - Quick Ref 3200 Sw
25	99-9397	1	Decal - Quick Ref 3200 Po
26	105-1703-03	1	Mount-Seat, LH

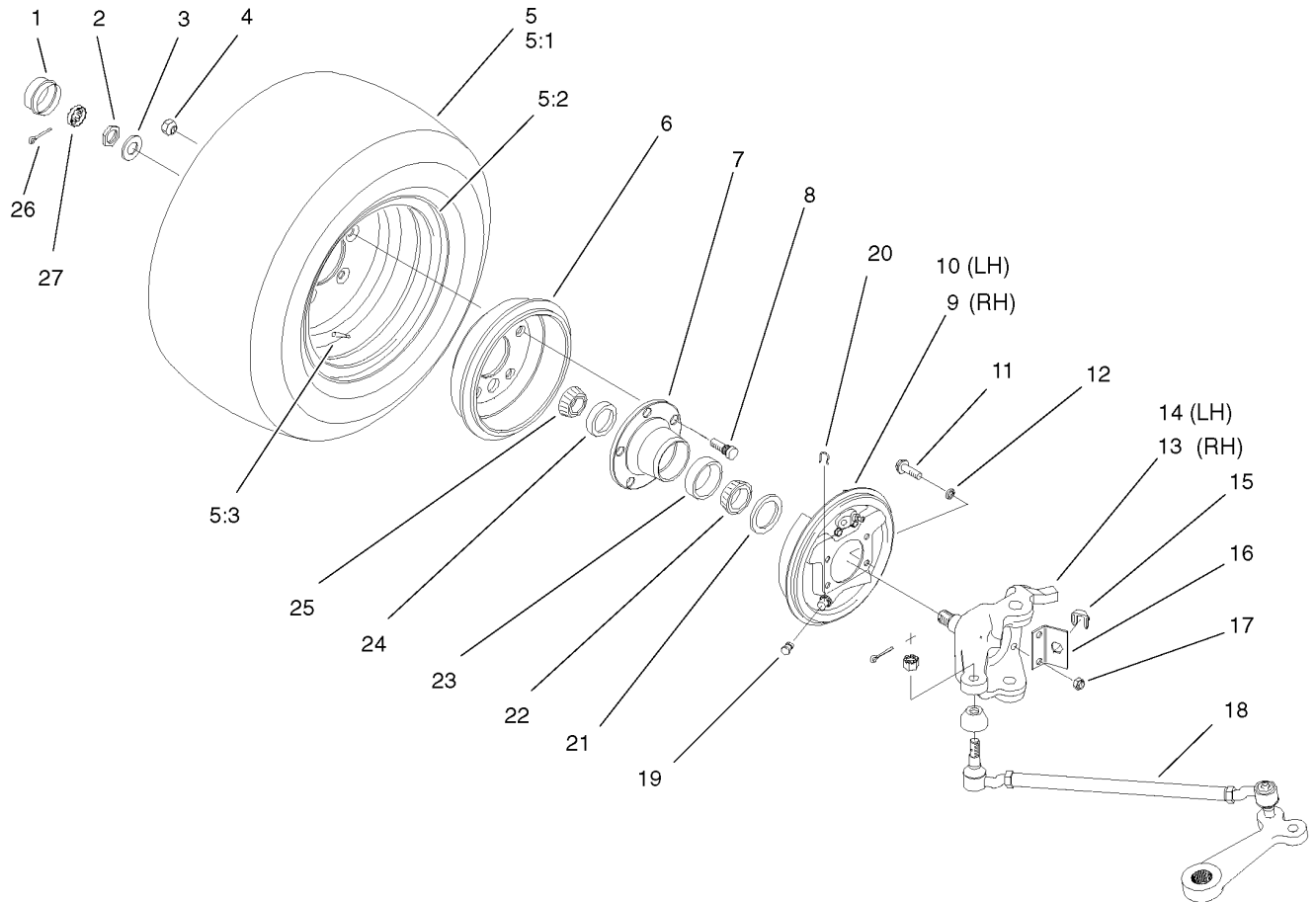

Front Wheel Assembly

Ref	Part No.	Qty.	Description
1	241-119	2	Cap-Dust
2	3220-7	2	Nut-Jam
3	93-0309	2	Washer-Tab
4	23-7270	10	Nut-Wheel
5:1	94-5261	1	Tire-Front
5:2	87-5720	1	Front Rim ASM
5:3	232-27	1	Stem-Valve
6	87-0270	2	Drum-Brake
7	87-5560	2	Hub-Front
8	87-8730	10	Stud
9	87-3010	1	RH Brake ASM
10	87-3020	1	LH Brake ASM
11	323-8	8	Screw-HH
12	3253-21	8	Washer-Lock
13	87-9430-03	1	Spindle-Sp Mask, RH
14	87-9440-03	1	Spindle-Sp Mask, LH
15	87-3580	2	Clip-Retainer
16	87-2820	2	Bracket-Spindle, Brake Hose
17	3296-39	8	Nut-Lock, NI
18		2	Rod-Tie
19	87-3450	2	Plug-Plate, Brake (Front)
20	87-3310	2	Clip-Cable, Brake
21	87-3590	2	Seal-Bearing
22	254-106	2	Cone-Bearing, Tapered

Ref	Part No.	Qty.	Description
23	254-107	2	Cup-Bearing, Tapered
24	254-72	2	Bearing-Cup, Tapered
25	254-94	2	Bearing-Cone, Tapered
26	3272-12	2	Pin-Cotter
27	93-0307	2	Nut-Lock, Retainer

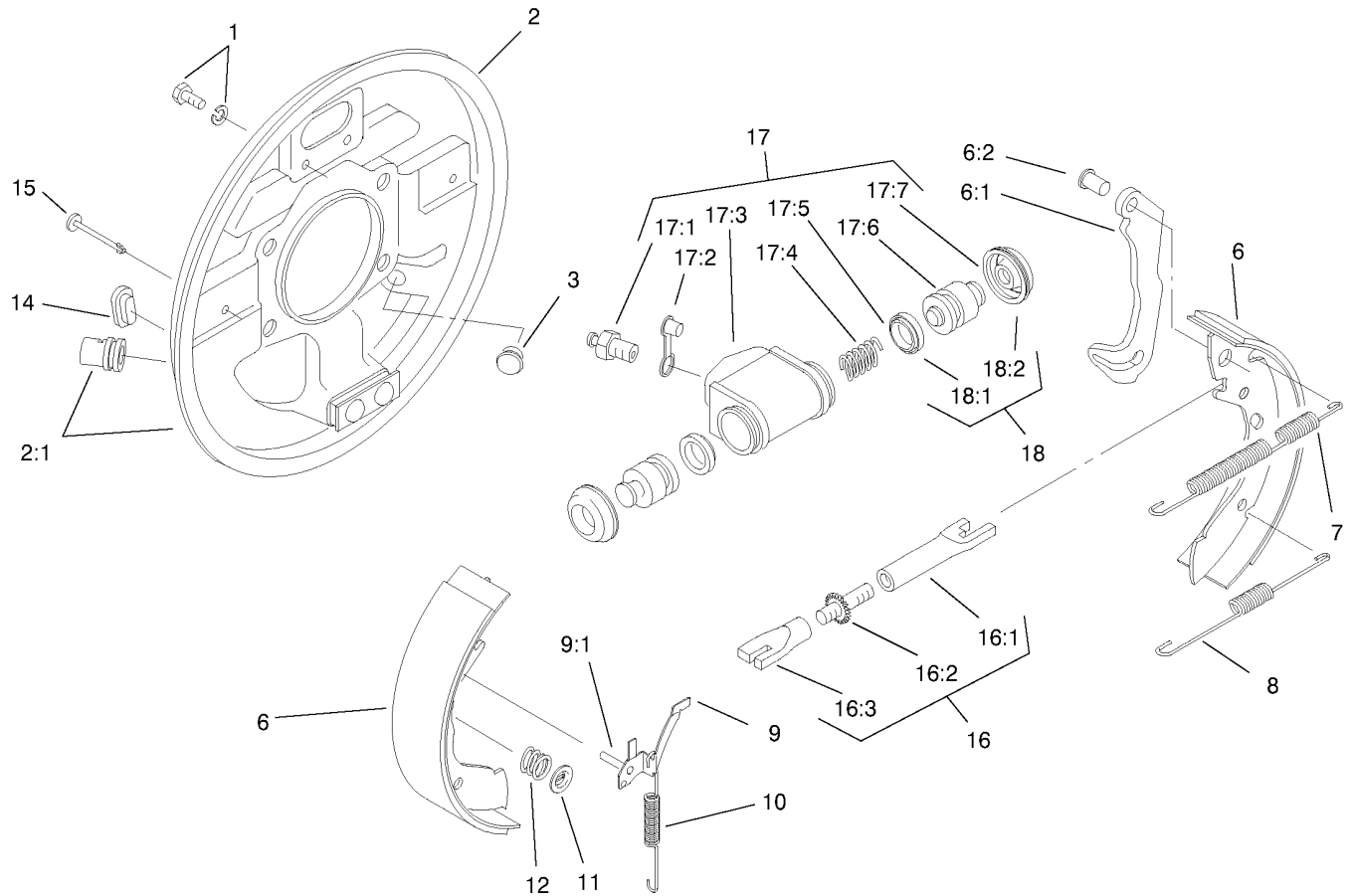

LH Front Brake Assembly No. 87-3020

Ref	Part No.	Qty.	Description
1	92-4135	2	Bolt-Set
2	92-4115	1	LH Backplate ASM
3	92-4125	1	Plug
6	92-4120	1	Kit-Shoe, Lined
●16:1		1	Lever-Operating
7	92-4126	1	Spring-Shoe Ret, Upper LH
8	92-4128	1	Spring-Shoe Ret, Lower
9	92-4123	1	LH Pawl Lever ASM
10	92-4129	1	Spring-Adjustor, LH
11	92-4131	2	Washer-Hold Down, Shoe
12	92-4132	2	Spring-Hold Down, Shoe
14	92-4134	1	Plug-Inspection
15	92-4133	2	Pin-Hold Down, Shoe
16	92-4121	1	LH Adjustor ASM
●16:1		1	Pushrod-Female
17	92-4117	1	Wheel Cylinder ASM
17:1	92-4113	1	Screw-Bleed
17:2	92-4114	1	Cap-Screw, Bleed
●17:5		2	Seal-L- Type
18	92-4119	1	Seal Kit
●18:1		2	Seal -L- Type

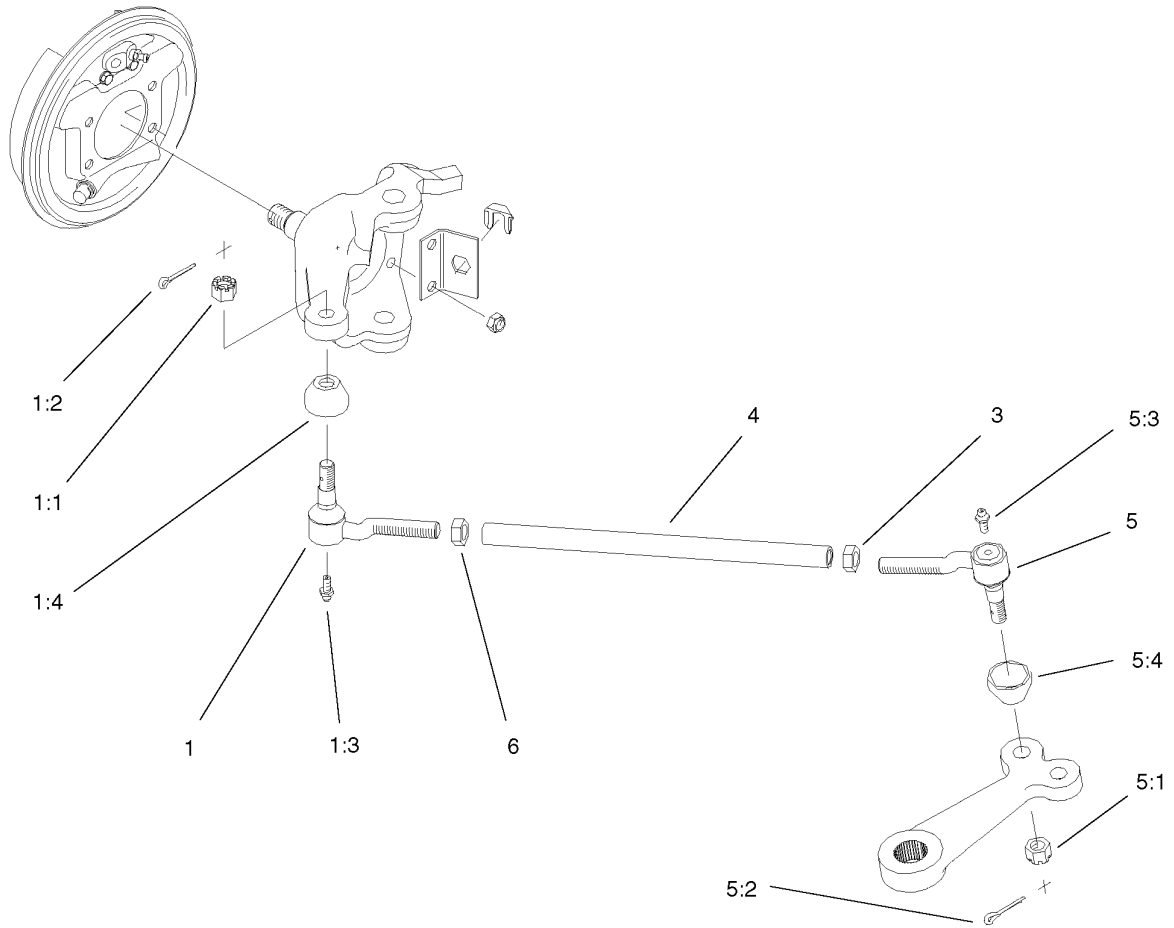

Tie Rod Assembly

Ref	Part No.	Qty.	Description
1	87-1480	1	RH Tie Rod End ASM
1:1	32136-3	1	Nut-SHH
1:2	3272-12	1	Pin-Cotter
1:3	302-5	1	Fitting-Grease
1:4	87-5340	1	Tie Rod Seal Kit
3	3218-21	1	Nut-Jam
4	87-2410-03	1	Tie Rod-Steering
5	87-1470	1	LH Tie Rod End ASM
5:1	32136-3	1	Nut-SHH
5:2	3272-12	1	Pin-Cotter
5:3	302-5	1	Fitting-Grease
5:4	87-5340	1	Tie Rod Seal Kit
6	3220-11	1	Nut-Jam

--	--	--	--

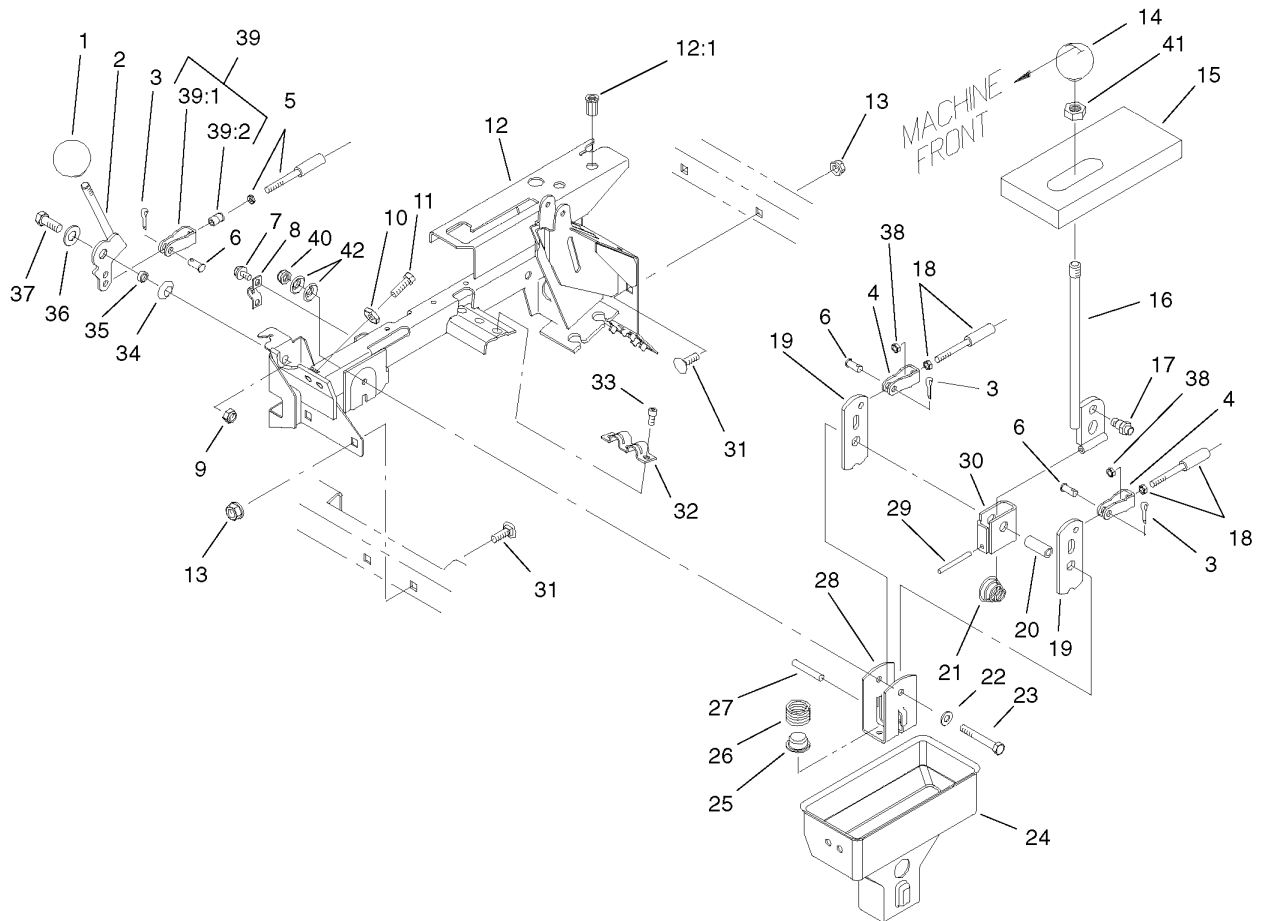

Center Console Assembly

Ref	Part No.	Qty.	Description
1	233-37	1	Knob
2	87-4350	1	Hi/Lo Lever ASM
3	3272-6	3	Pin-Cotter
4	87-2310	2	Clevis-Cable
5	87-4420	1	Cable-Hi/Lo
6	283-62	3	Pin-Clevis
7	32144-4	2	Screw-HWH
8	87-4340	1	Clamp-Cable
9	3296-39	1	Nut-Lock, NI
10	3220-3	2	Nut-Hex, Jam
11	3211-8	2	Screw-HH
12	94-5202	1	Lever Support ASM
12:1	32148-7	2	Insert-Nut
13	3290-357	4	Nut-HHF, Whiz
14	87-6720	1	Knob-Shift
15	87-6570	1	Seal-Boot, Lower
16	87-2040	1	Shift Lever ASM
17	87-3650	1	Pin-Shift
18	87-4260	2	Cable-Selector, Gear
19	87-3540	2	Link-Shift
20	87-2520	1	Tube-Pivot
21	87-2900	1	Spring-Compression
22	87-8640	1	Washer-Flat
23	322-12	1	Screw-HH

Ref	Part No.	Qty.	Description
24	87-2260	1	Boot-Shift, Lower
25	87-3530	1	Button-Shifter
26	87-3660	1	Spring-Compression
27	3290-507	1	Pin-Dowel
28	87-3520	1	Clevis
29	32121-48	1	Pin-Spring
30	87-6040	1	Bracket-Shifter
31	3231-21	4	Screw-CARR
32	87-4960	1	Clamp-Cable
33	65-5220	3	Screw-Forming, Thread
34	3290-221	1	Washer-Spring
35	76-9100	1	Spacer-Speed, Reel
36	49-9150	1	Washer-Pivot
37	323-6	1	Screw-HH
38	3220-1	2	Nut-Jam
39	87-7160	1	Cable Clevis ASM
39:1	87-2310	1	Clevis-Cable
39:2	32148-15	1	Nut-Insert
40	3296-58	1	Nut-Lock, NI
41	3218-18	1	Nut-Jam
42	3290-456	2	Washer-Belleville

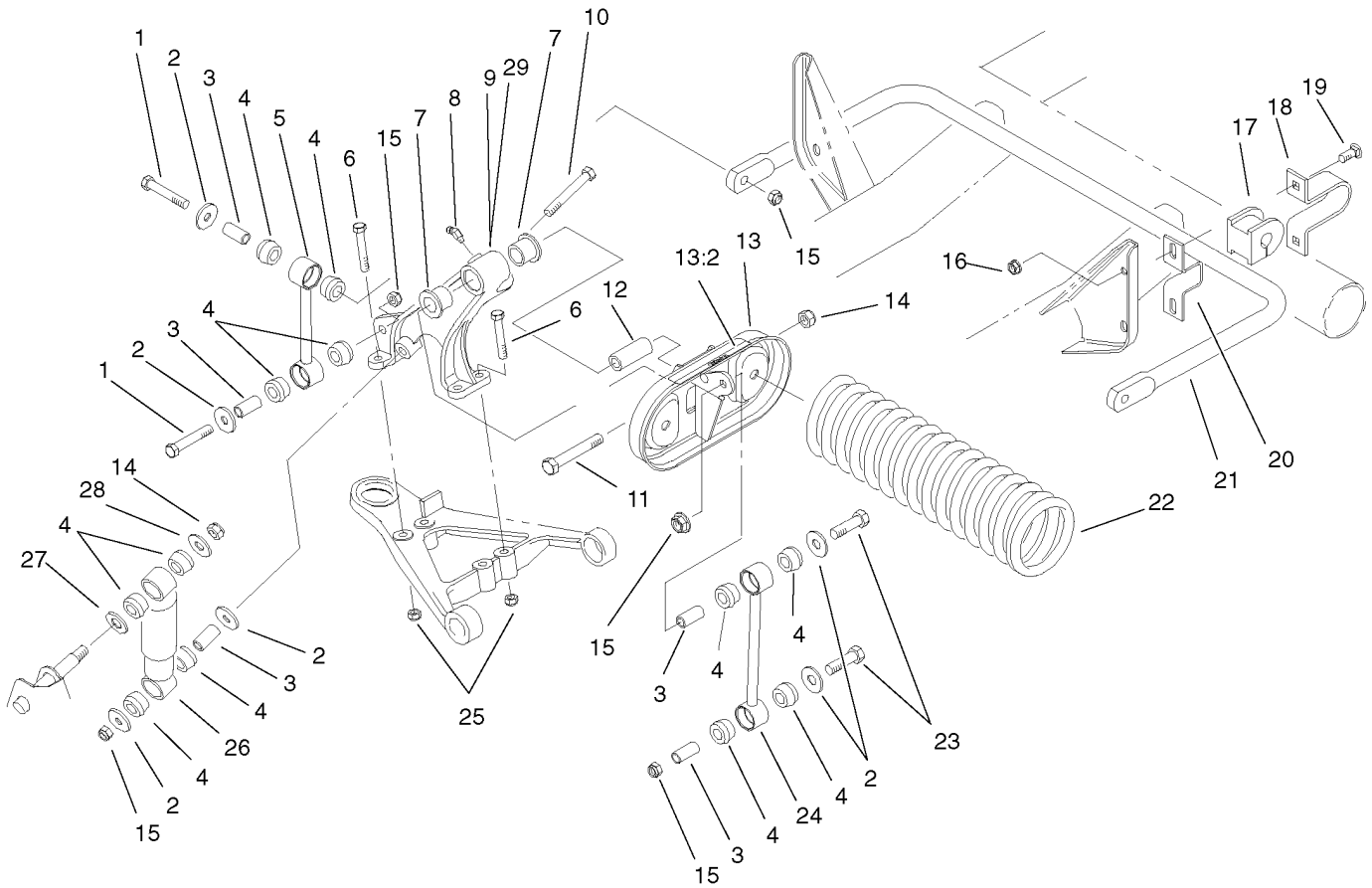

Front Suspension Assembly

Ref	Part No.	Qty.	Description
1	324-10	4	Screw-HH
2	87-5330	12	Washer
3	87-3600	10	Spacer-Absorber, Shock
4	87-3920	24	Bushing
5	87-3860-03	2	Anti-Sway Bar Link ASM
6	323-12	8	Screw-HH
7	33-3090	4	Bushing
8	302-11	2	Fitting-Lube, 45 DEG
9	87-0150-03	1	Tower-Control Arm, RH
10	324-13	2	Screw-HH
11	325-13	2	Screw-HH
12	87-2500	2	Sleeve-Spring, Pivot
13	105-7958	2	Spring Cradle ASM
13:2	93-9879	1	Decal-Warning
14	3296-23	4	Nut-Lock, NI
15	3296-48	10	Nut-Lock, NI
16	3290-357	4	Nut-HHF, Whiz
17	87-3910	2	Bushing-Rubber
18	87-4010-03	2	Clamp-Bar, Sway
19	3231-25	4	Screw-CARR
20	87-3890-03	2	Bracket-Bar, Sway
21	87-3850-03	1	Bar-Sway, Anti
22	105-4183-01	2	Spring-Compression
23	324-9	4	Screw-HH

Ref	Part No.	Qty.	Description
24	87-2480-03	2	Stabilizer Link ASM
25	3296-39	8	Nut-Lock, NI
26	87-3110	2	Absorber-Shock
27	3256-27	2	Washer-Flat
28	3256-6	2	Washer-Flat
29	87-0160-03	1	Tower-Control Arm, LH

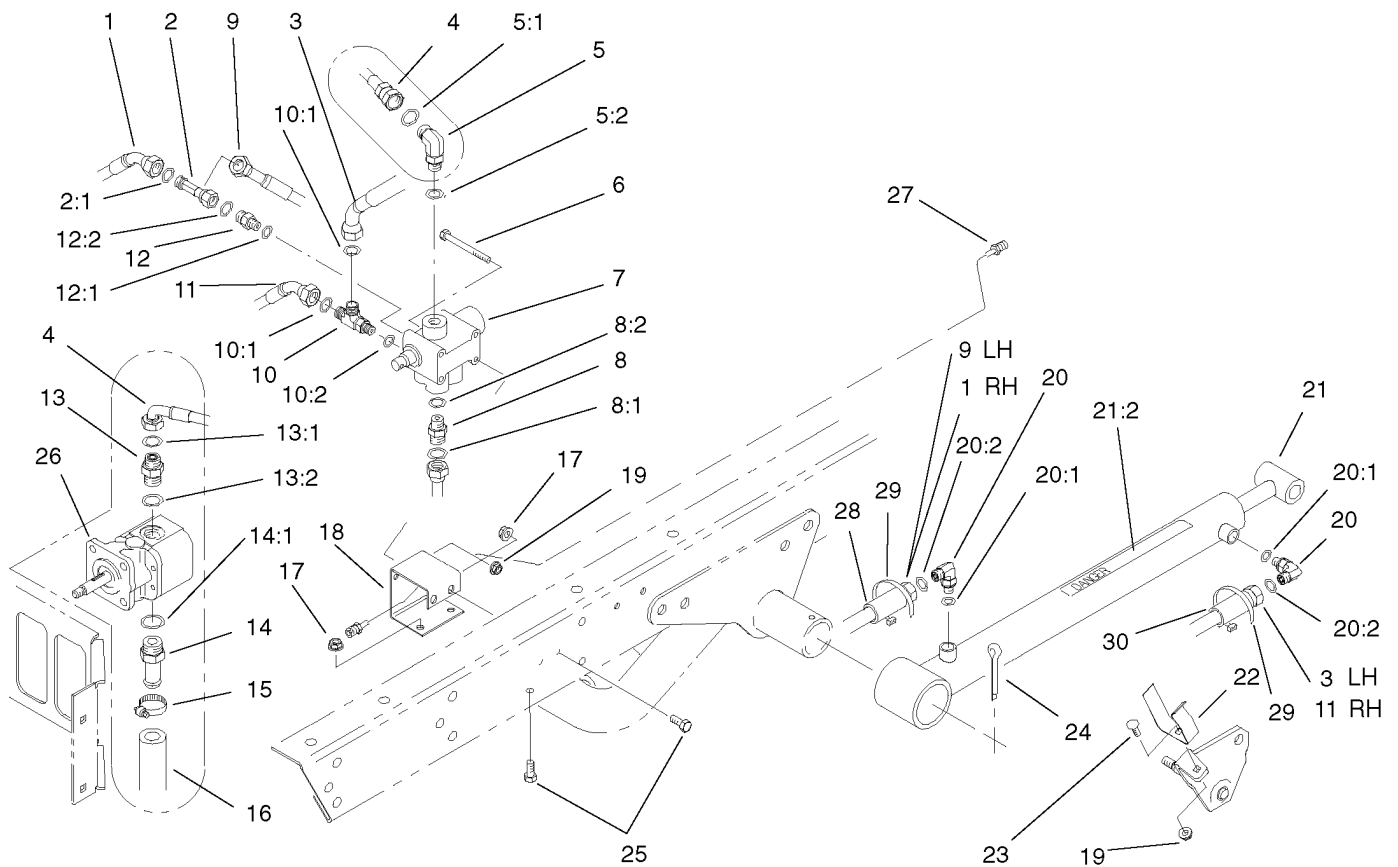

Lift Valve and Cylinder Assembly

Ref	Part No.	Qty.	Description
1	87-4900	1	Hose ASM
2	340-151	1	Fitting
2:1	237-75	3	O-Ring
3	92-2697	1	Hose ASM
4	93-9552	1	Hose ASM
5	340-77	1	Fitting-HYD, 90 DEG
5:1	237-22	1	O-Ring
5:2	237-42	1	O-Ring
6	321-14	2	Screw-HH
7	43-1950-03	1	Valve-HYD
8	340-77	1	Fitting-HYD, 90 DEG
8:1	237-22	1	O-Ring
8:2	237-42	1	O-Ring
9	87-4880	1	Hose ASM
10	340-140	1	Adapter-Tee
10:1	237-21	2	O-Ring
10:2	237-78	1	O-Ring
11	87-4910	1	Hose ASM
12	340-92	1	Fitting-HYD, Straight
12:1	237-78	1	O-Ring
12:2	237-21	1	O-Ring
13	340-3	1	Adapter
13:1	237-22	1	O-Ring
13:2	237-79	1	O-Ring

Ref	Part No.	Qty.	Description
14	354-136	1	Fitting-HYD
14:1	237-80	1	O-Ring
15	2412-34	1	Clamp-Hose
16	87-3670	1	Hose-Suction
17	32128-20	4	Nut-HF
18	87-4520-03	1	Bracket-Dump Valve
19	32128-33	4	Nut-HF
20	340-132	4	Fitting-HYD, 90 DEG
20:1	237-78	1	O-Ring
20:2	237-21	1	O-Ring
21	105-7957	2	HYD Lift Cylinder ASM
21:2	93-9852	1	Decal-Warning
22	87-3720	2	Retainer-Cylinder
23	3229-1	2	Screw-CARR
24	3272-37	2	Pin-Cotter
25	322-3	4	Screw-HH
26	87-5700	1	Gear-HYD Pump
27	94-3844	1	LH Rear Brake Tube ASM
28	24-7922	1	Cover-Shaft, Drive
29	3290-378	6	Tie-Cable
30	24-7923	2	Cover-Shaft, Drive

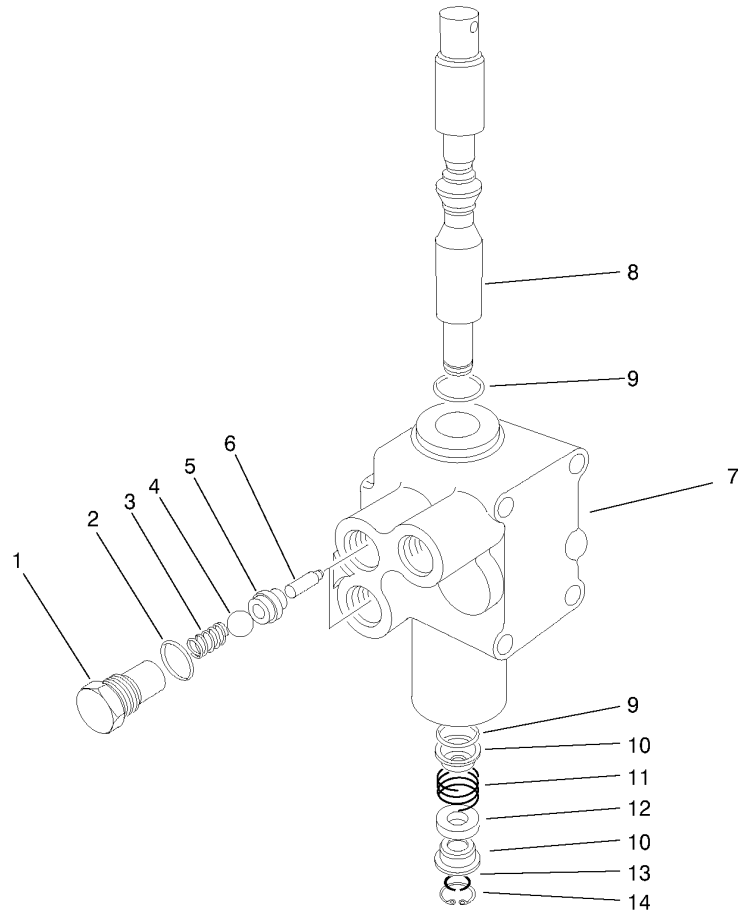

Hydraulic Valve Assembly No. 43-1950-03

Ref	Part No.	Qty.	Description
1	22-8330	2	Plug
2	237-42	2	O-Ring
3	22-8340	2	Spring
4	22-8350	2	Ball
5	22-8370	2	Seat-Valve
6	22-8360	2	Pin
8	22-8420	1	Spool
9	22-8500	2	O-Ring
10	22-8380	2	Retainer
11	22-8410	1	Spring
12	23-3030	1	Spacer
13	22-8480	1	Ring-Snap
14	22-8490	1	Ring-Snap

--	--	--	--

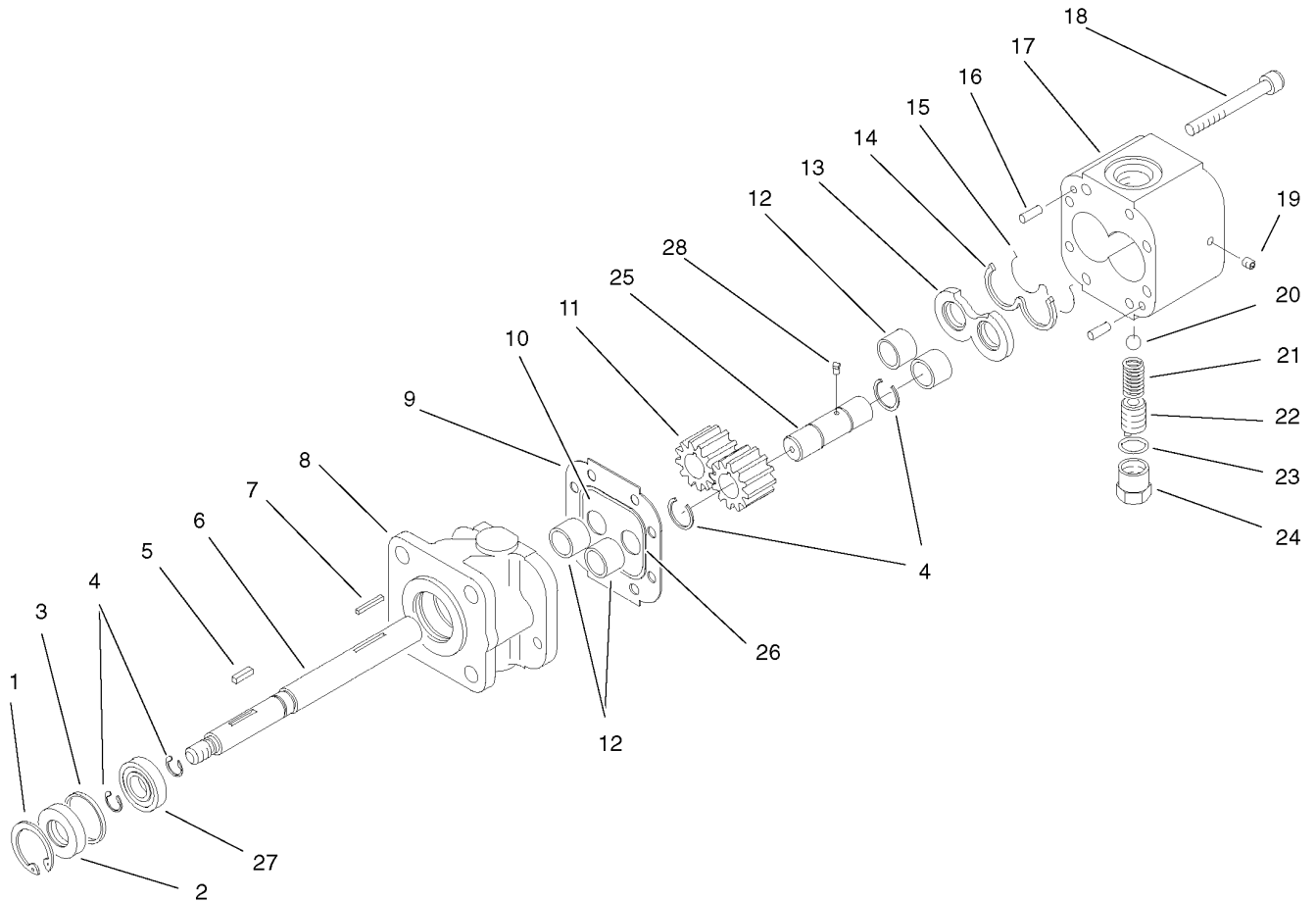

Hydraulic Gear Pump Assembly No. 87-5700

Ref	Part No.	Qty.	Description
1	32151-41	1	Ring-Snap
2	92-2195	1	Seal-Oil
3	92-2186	1	Spacer
4	92-2178	4	Ring-Crescent
5	92-2179	1	Key-Square
6	92-2189	1	Shaft-Drive
7	92-2177	1	Pin-Shear
8	92-2188	1	Stator
9	92-2182	1	Plate-Seal
10	92-2183	1	Plate-Wear
11	92-2175	2	Gear
12	92-2192	4	Bearing
13	92-2181	1	Plate-Pressure
14	92-2197	1	Seal-Back Up, Pressure Plate
15	92-2196	1	Seal-Plate, Pressure
16	92-2176	2	Pin-Shear
17	92-2187	1	Housing-Gear, End
18	92-2173	4	Screw
19	92-2185	1	Plug
20	92-2193	1	Ball-Steel
21	92-2194	1	Spring
22	92-2174	1	Screw-Adjusting
23	92-2180	1	Gasket-Copper
24	92-2184	1	Cap-Hex, Relief Valve

Ref	Part No.	Qty.	Description
25	92-2190	1	Shaft-Idler
26	92-2198	1	Seal-Plate, Wear
27	92-2191	1	Bearing-Ball
28	92-2199	1	Key-Ball

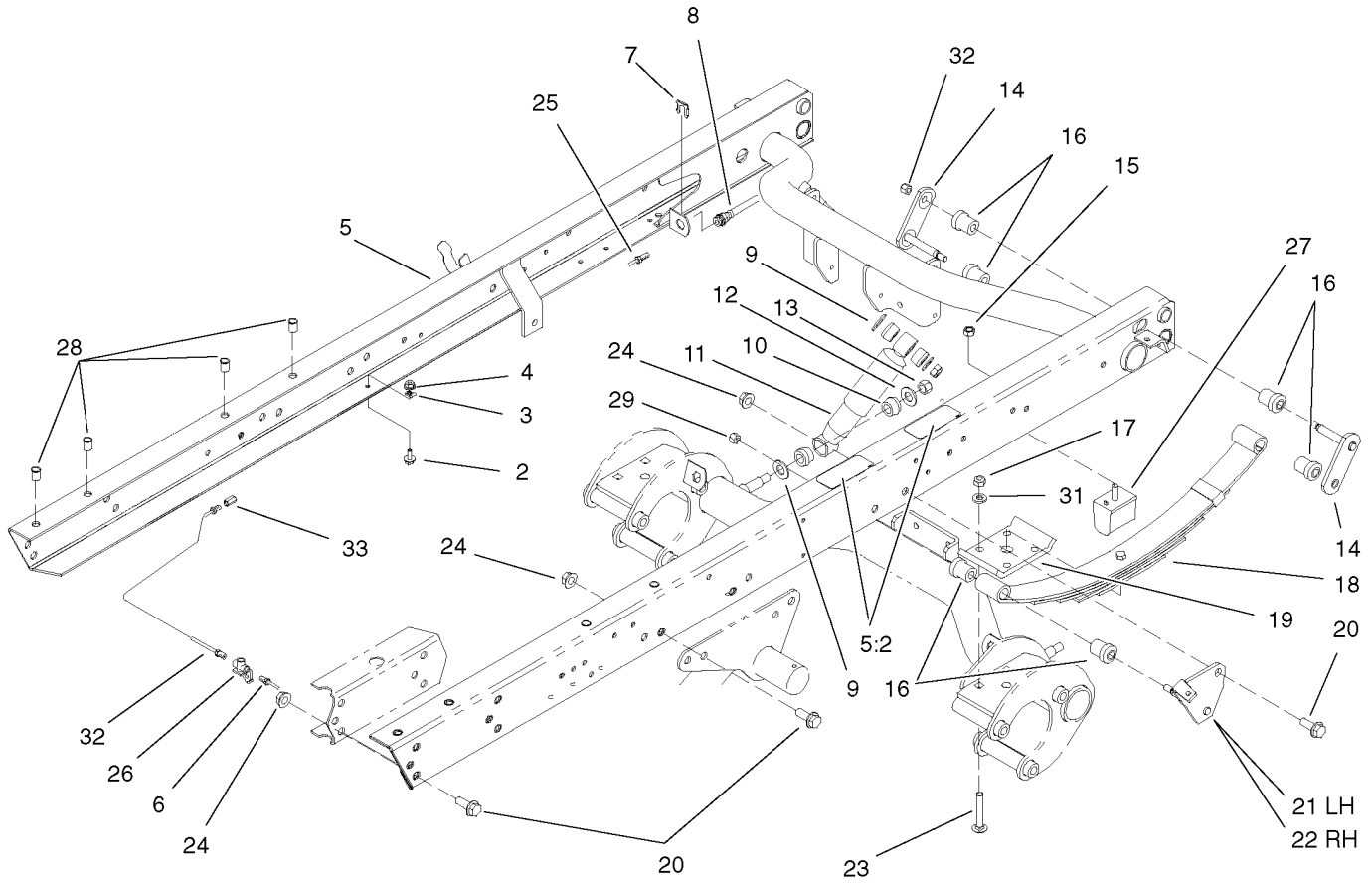

Rear Frame Assembly

Ref	Part No.	Qty.	Description
2	3234-4	3	Screw-HHF
3	2412-149	4	Clamp-Hose
4	32128-33	4	Nut-HF
5	105-7959	1	Frame Channel ASM
5:2	93-8071	2	Decal-Surface, Hot
6	94-3843	1	LH Rear Brake Tube ASM
7	87-3580	2	Clip-Retainer
8	87-4100	2	Hose-Brake, Rear
9	3256-27	4	Washer-Flat
10	87-3920	8	Bushing
11	87-3110	2	Absorber-Shock
12	3256-6	4	Washer-Flat
13	3296-23	4	Nut-Lock, NI
14	87-3980	4	Shackle ASM
15	48-9520	2	Nut
16	87-4760	12	Bushing-Rubber
17	3296-76	8	Nut-Lock, NI
18	87-1490	2	Spring-Leaf, Rear
19	87-7470-03	2	Plate-Spring, Clamp
20	3234-38	24	Screw-HHF
21	87-3960	1	LH Spring Mount ASM
22	87-3940	1	RH Spring Mount ASM
23	3232-17	8	Screw-CARR
24	32128-23	24	Nut-HF

Ref	Part No.	Qty.	Description
25	94-3846	1	RH Rear Brake Tube ASM
26	87-3560	1	Tee
27	87-3470	2	Bumper-Axle, Rear
28	32148-9	8	Insert-Nut
29	3296-39	6	Nut-Lock, NI
31	87-7480	8	Washer
32	94-3845	1	RH Rear Brake Tube ASM
33	87-3570	2	Union

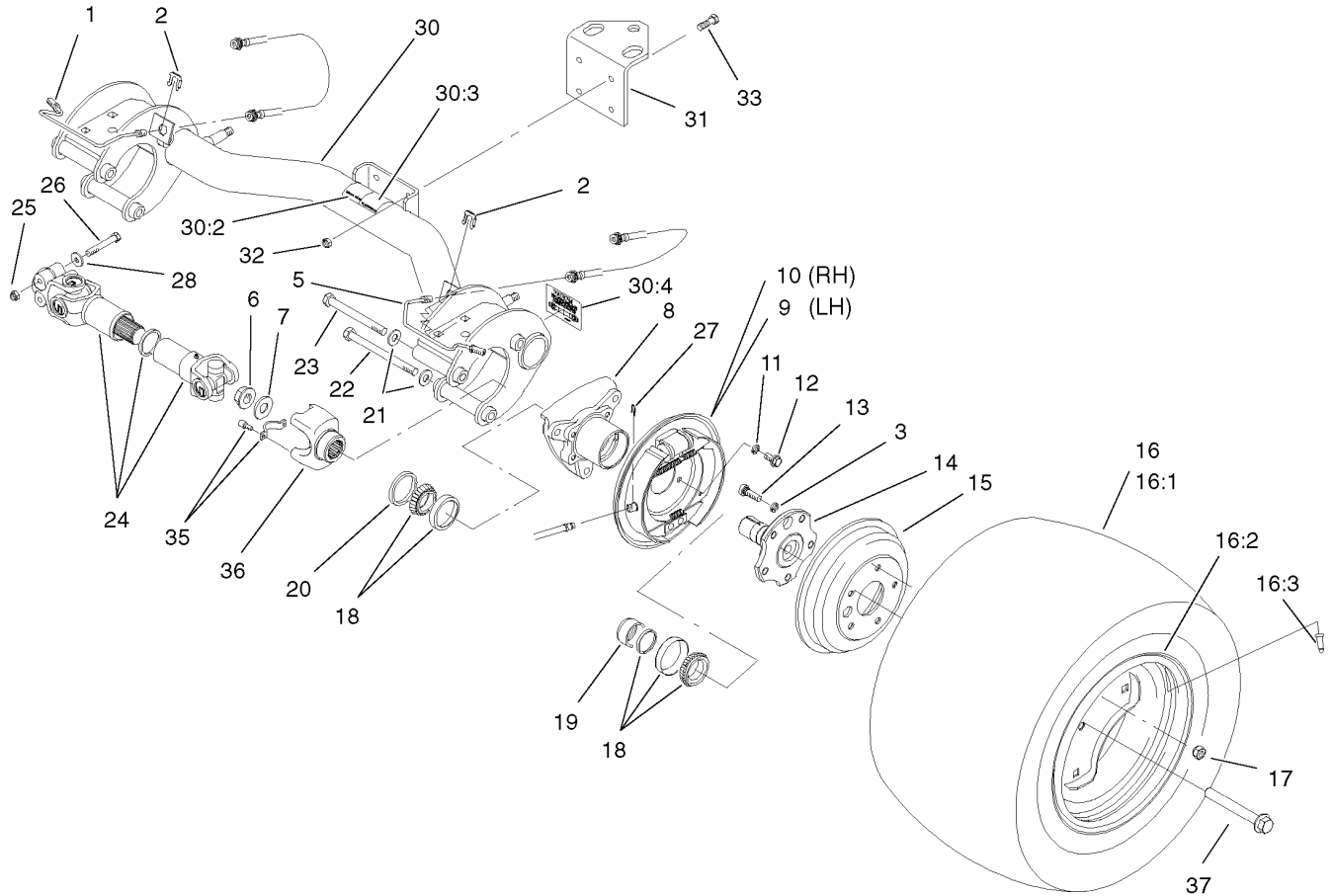

Rear Axle Assembly

Ref	Part No.	Qty.	Description
1	87-4090	1	RH Rear Brake Tube ASM
2	87-3580	2	Clip-Retainer
3	3253-6	10	Washer-Lock
5	87-4080	1	LH Rear Brake Tube ASM
6	105-1764	2	Nut-Flange, Side Lock
7	104-9216	2	Washer-Hardened
8	87-2240-03	2	Housing-Axle
9	93-7126	1	LH Rear Brake ASM
10	93-7125	1	RH Rear Brake ASM
11	3253-21	8	Washer-Lock
12	323-6	8	Screw-HH
13	87-2080	10	Bolt-Hex, TAP
14	105-1717-03	2	Axle-Stub
15	93-7128	2	Drum-Brake
16:1	105-1781	1	Tire
16:2	87-6750	1	Wheel
16:3	232-27	1	Stem-Valve
17	23-7270	10	Nut-Wheel
18	87-1970	2	Bearing
19	87-4060	2	Spacer-Bearing, Wheel
20	87-3590	2	Seal-Bearing
21	87-7270	6	Washer-Thrust
22	325-20	5	Screw-HH
23	325-19	1	Screw-HH

Ref	Part No.	Qty.	Description
24	98-2918	2	Driveshaft ASM
25	32128-36	4	Nut-HF
26	98-2939	4	Screw-Cap
27	87-3310	2	Clip-Cable, Brake
28	80-6990	4	Washer-Hardened
30	105-7961	1	Rear Axle ASM
30:2	93-9442	1	Decal-Atf
30:3	93-9862	1	Decal-Danger
30:4	93-9449	2	Decal-Driveshaft
31	92-5951-03	1	Angle-Hitch
32	3296-39	4	Nut-Lock, NI
33	323-7	4	Screw-HH
35	92-4189	2	Strap Kit
36	92-4190	2	Yoke
37	105-1763	2	Screw-HHF

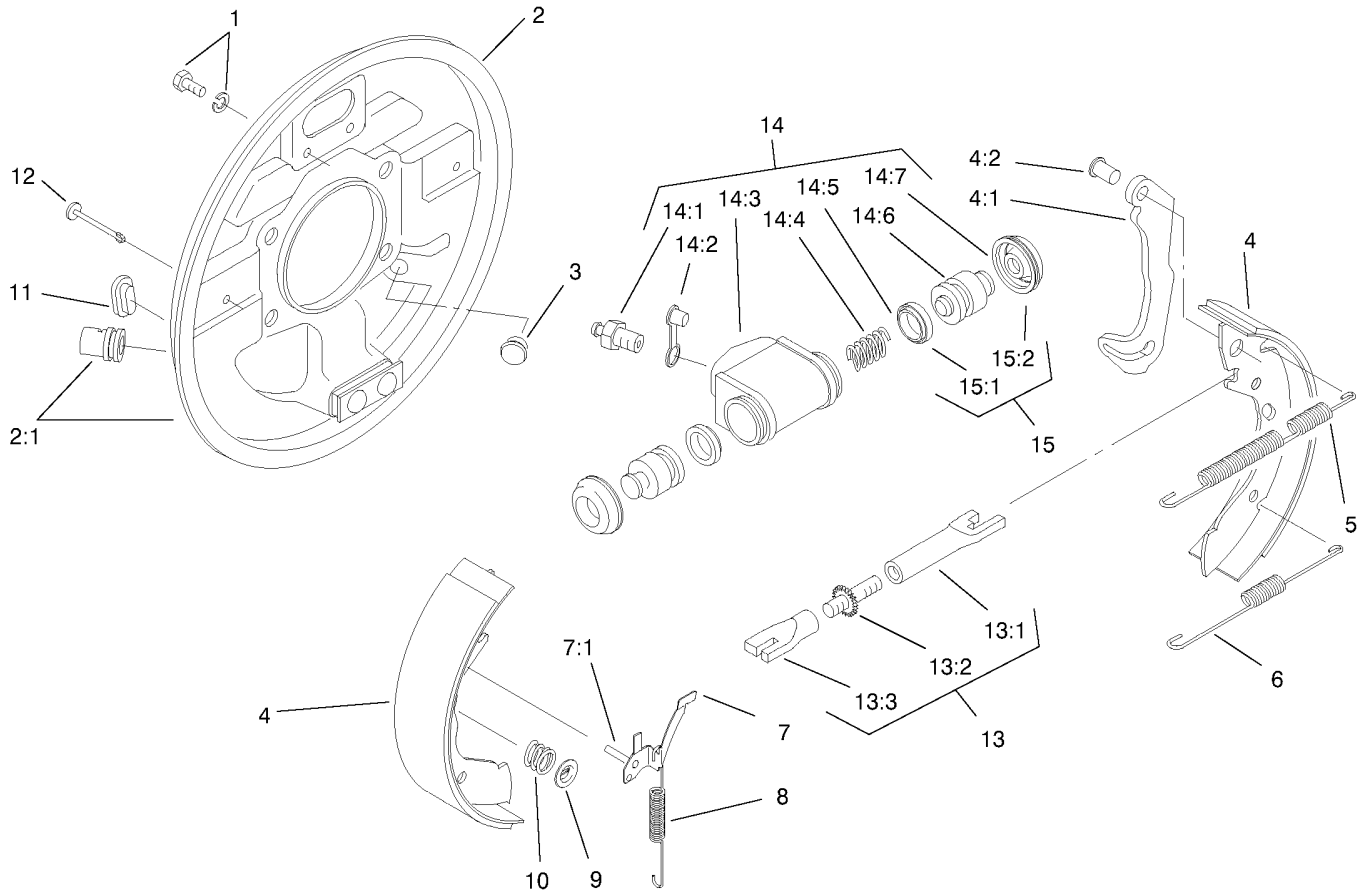

LH Rear Brake Assembly No. 93-7126

Ref	Part No.	Qty.	Description
1	92-4135	2	Bolt-Set
2	92-4136	1	LH Backplate ASM
3	92-4146	1	Plunger ASM
4	92-4143	1	Lined Shoe Kit
④4:1		1	Lever-Operating
5	92-4147	1	Spring-Return, Shoe (Upper, LH)
6	92-4149	1	Spring-Return, Shoe (Lower)
7	92-4123	1	LH Pawl Lever ASM
8	92-4150	1	Spring-Adjuster, LH
9	92-4131	2	Washer-Hold Down, Shoe
10	92-4152	2	Spring-Hold Down, Shoe
11	92-4134	1	Plug-Inspection
12	92-4133	2	Pin-Hold Down, Shoe
13	92-4144	1	LH Adjuster ASM
①13:1		1	Pushrod-Female
14	92-4140	1	LH Wheel Cylinder ASM
14:1	92-4137	1	Screw-Bleed
14:2	92-4114	1	Cap-Screw, Bleed
15	92-4142	1	Seal Kit

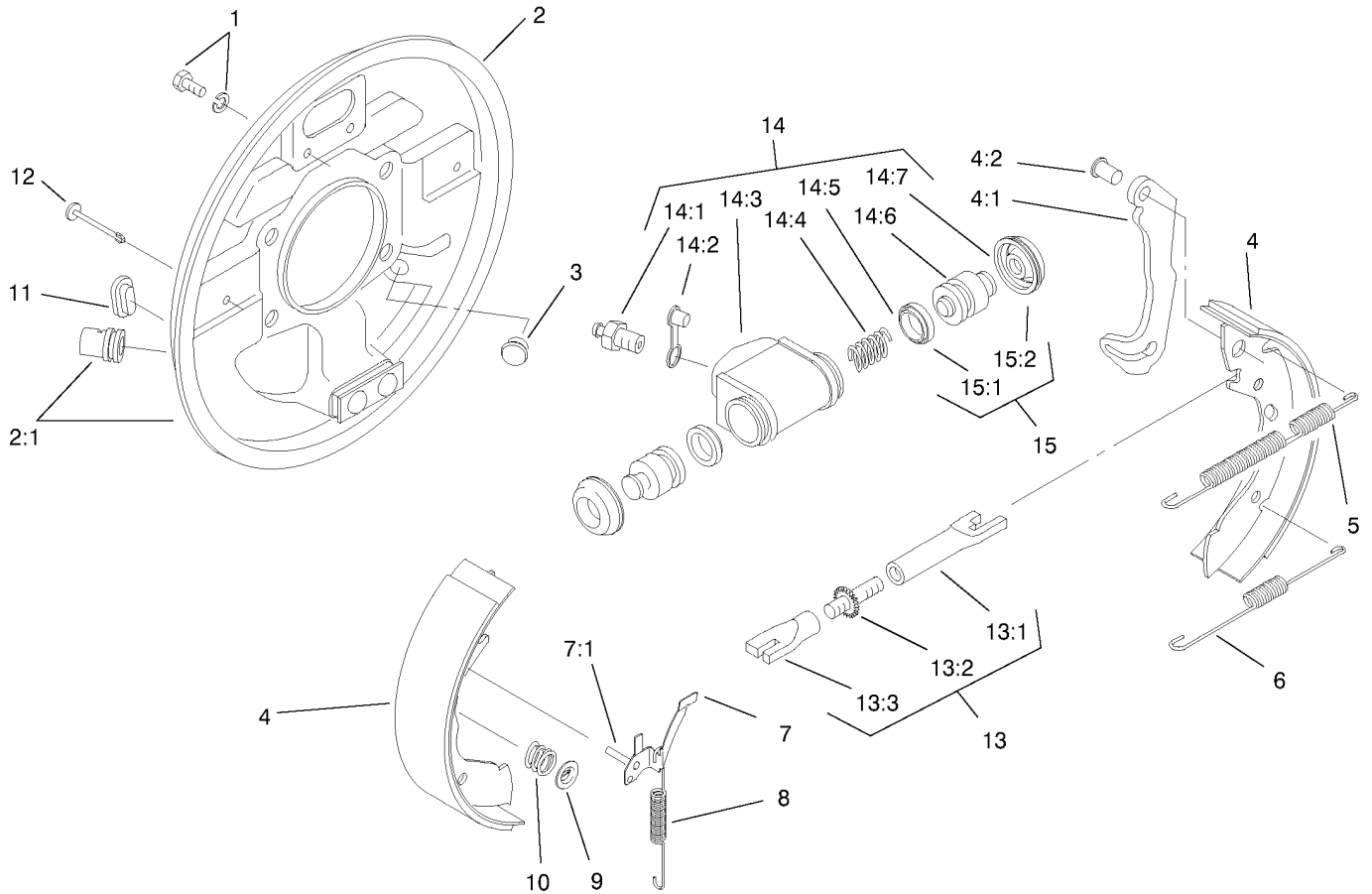

RH Rear Brake Assembly No. 93-7125

Ref	Part No.	Qty.	Description
1	92-4135	2	Bolt-Set
2	92-4100	1	RH Backplate ASM
3	92-4146	1	Plunger ASM
4	92-4143	1	Lined Shoe Kit
●4:1		1	Lever-Operating
5	92-4148	1	Spring-Return, Shoe (Upper, RH)
6	92-4149	1	Spring-Return, Shoe (Lower)
7	92-4124	1	RH Pawl Lever ASM
8	92-4151	1	Spring-Adjuster, RH
9	92-4131	2	Washer-Hold Down, Shoe
10	92-4152	2	Spring-Hold Down, Shoe
11	92-4134	1	Plug-Inspection
12	92-4133	2	Pin-Hold Down, Shoe
13	92-4145	1	RH Adjustor ASM
●13:1		1	Pushrod-Female
14	92-4141	1	RH Wheel Cylinder ASM
14:1	92-4137	1	Screw-Bleed
14:2	92-4114	1	Cap-Screw, Bleed
●14:5		2	Seal-L- Type
15	92-4142	1	Seal Kit

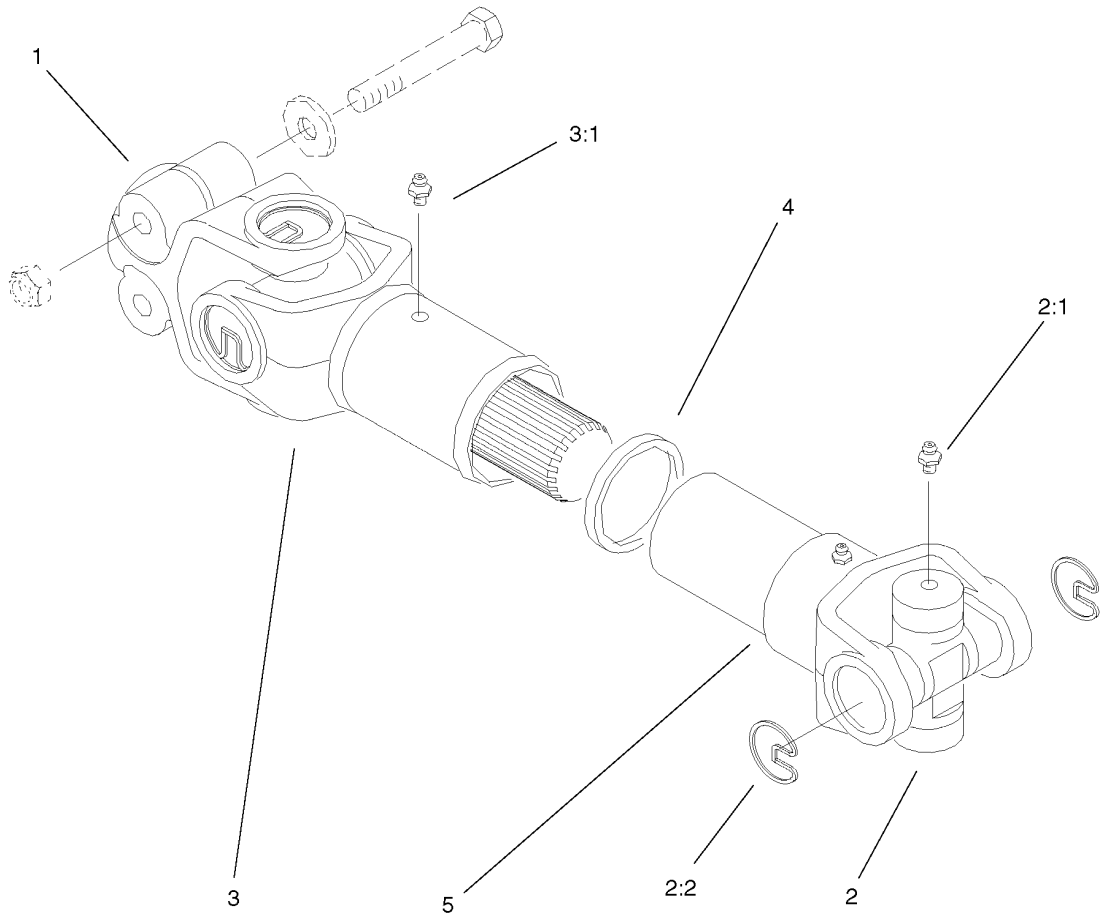

Driveshaft Assembly No. 98-2918

Ref	Part No.	Qty.	Description
1	98-2940	1	Yoke
2	92-4187	2	Cross And Bearing Kit
2:1	302-58	2	Fitting-Grease
2:2	92-4188	2	Ring-Snap
3	92-4179	1	Yoke-Tube, Shaft And Seal
3:1	302-5	1	Fitting-Grease
4	92-4180	1	Seal
5	92-4182	1	Yoke And Hub

--	--	--	--

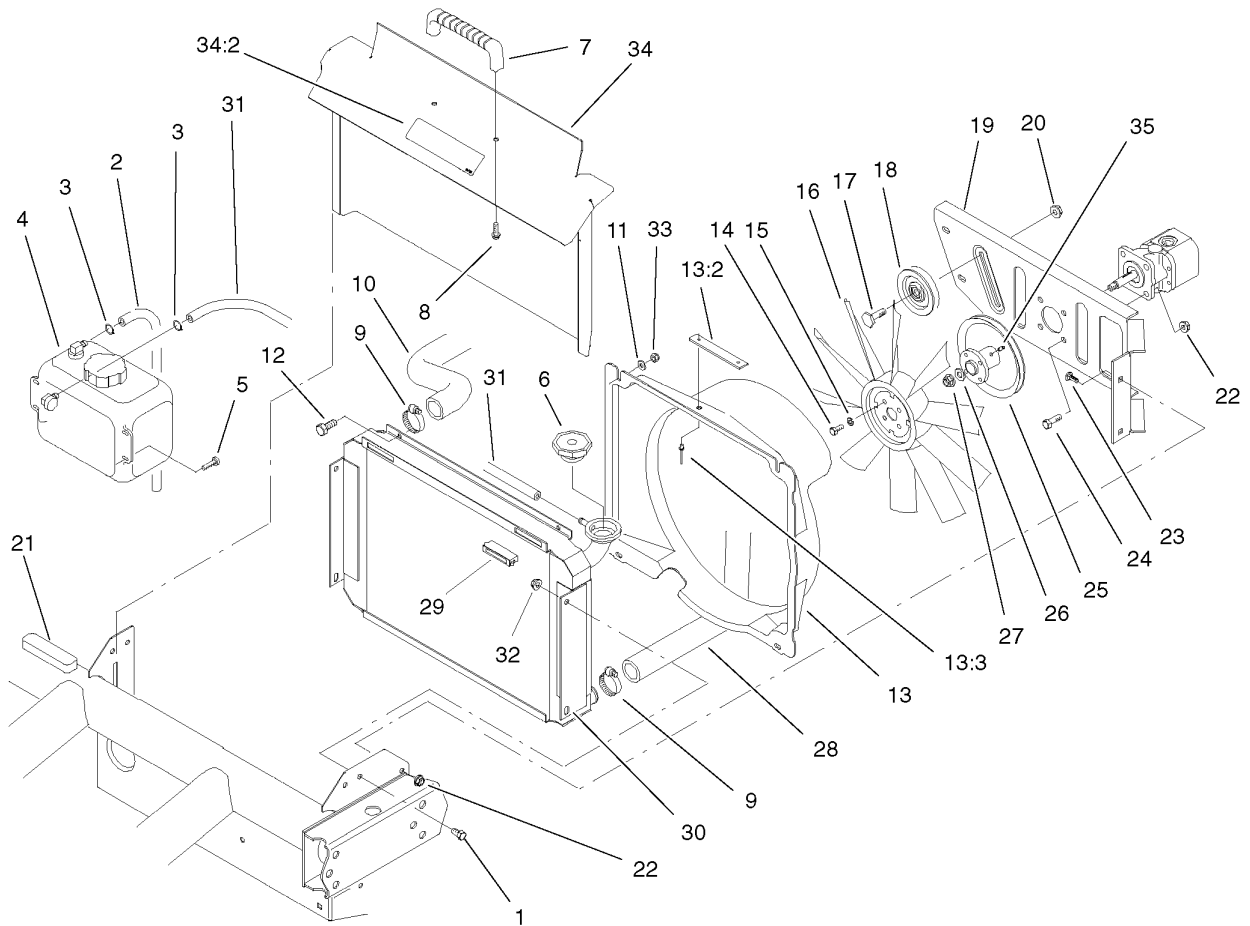

Radiator and Hydraulic Pump Assembly

Ref	Part No.	Qty.	Description
1	322-2	4	Screw-HH
2	71-3381	1	Hose-Fuel
3	92-2379	2	Clamp-Hose
4	87-3710	1	Reservoir-Coolant
5	3250-20	4	Screw-PPH
6	66-3240	1	Cap-Radiator
7	65-5100	1	Handle-Door
8	46-8091	2	Screw-HWH
9	2412-34	2	Clamp-Hose
10	105-1724	1	Hose-Radiator, Upper
11	3256-22	4	Washer-Flat
12	321-4	4	Screw-HH
13	105-7956	1	Fan Shroud ASM
13:2	98-9335	1	Plate-Warning, Fan
13:3	3290-271	2	Rivet-Pop
14	321-3	4	Screw-HH
15	3253-3	4	Washer-Lock
16	84-1880	1	Fan
17	32141-86	1	Screw-Leveler
18	63-8140	1	Pulley-Idler
19	93-7088-03	1	Plate-Mount, Pump
20	3290-357	1	Nut-HHF, Whiz
21	87-9810	1	Foam-Overflow, Tank
22	3296-29	8	Nut-Lock, NI

Ref	Part No.	Qty.	Description
23	3230-23	4	Screw-CARR
24	322-5	4	Screw-HH
25	94-5237	1	Fan Hub ASM
26	3256-45	1	Washer-Flat
27	3296-5	1	Nut-Lock
28	105-1725	1	Hose-Radiator, Lower
29	58-4250	2	Catch-Magnetic
30	93-7051	1	Radiator
31	71-3383	1	Hose-Fuel
32	32128-20	4	Nut-HF
33	3296-42	4	Nut-Lock, NI
34	105-4223	1	Radiator Cover ASM
34:2	93-9447	1	Decal-Caution
35	3245-31	1	Screw-HSH

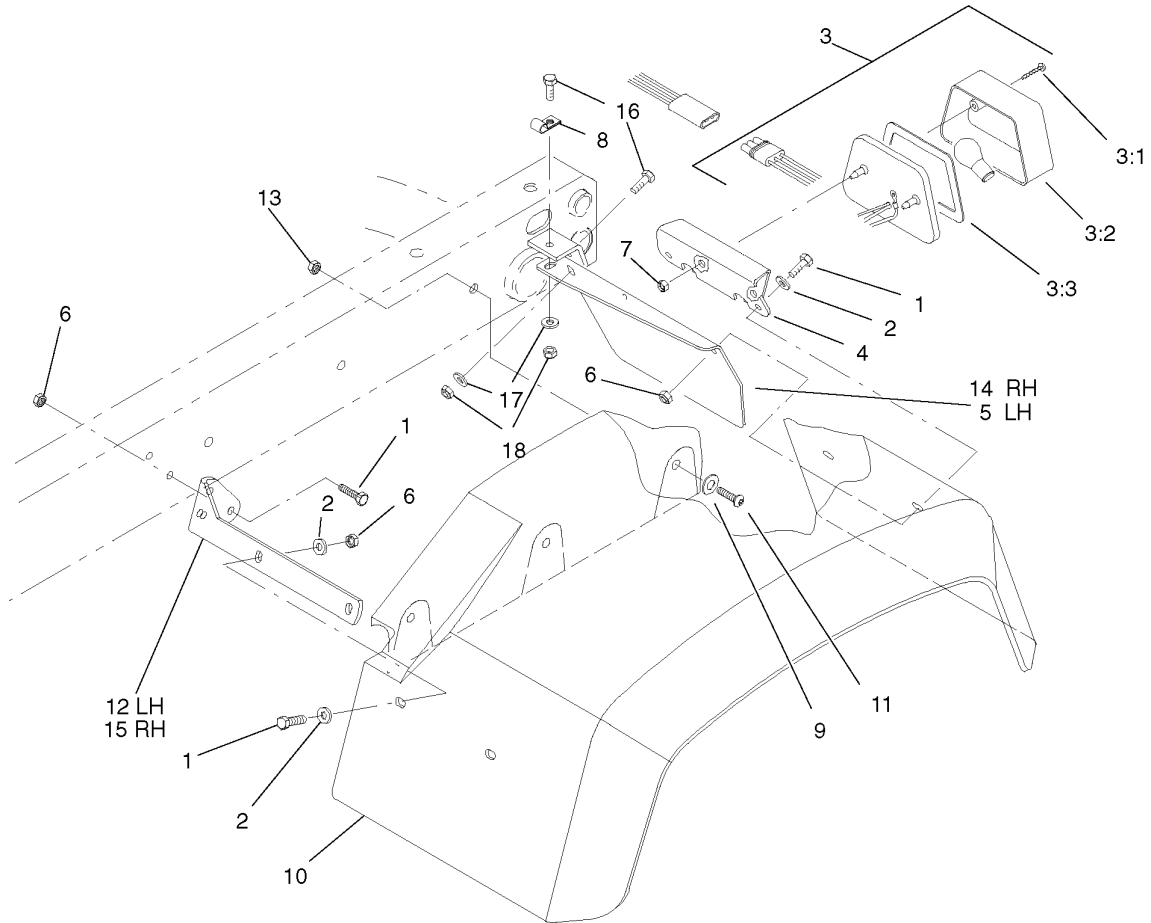

Tail Light and Fender Assembly

Ref	Part No.	Qty.	Description
1	321-6	12	Screw-HH
2	3256-22	12	Washer-Flat
3	87-2110	1	Light-Tail / Brake
3:1	32144-93	4	Screw-PPHTF
3:2	87-6300	2	Lens-Light, Tail
3:3	87-6310	2	Gasket-Light, Tail
4	87-5770-03	1	Bracket-Light, Tail
5	93-8943-03	1	Bracket-Fender, LH Rear
6	3296-42	14	Nut-Lock, NI
7	3290-506	2	Palnut
8	2412-93	1	Clamp-R
9	3256-24	6	Washer-Flat
10	87-6660	2	Fender-Rear, 24 Inch
11	3274-94	6	Screw-HSBH
12	93-8941-03	1	Bracket-Fender, Front LH
13	3296-39	6	Nut-Lock, NI
14	93-8944-03	1	Bracket-Fender, Rear RH
15	93-8942-03	1	Bracket-Fender, Front RH
16	322-5	4	Screw-HH
17	3256-23	4	Washer-Flat
18	3296-29	4	Nut-Lock, NI

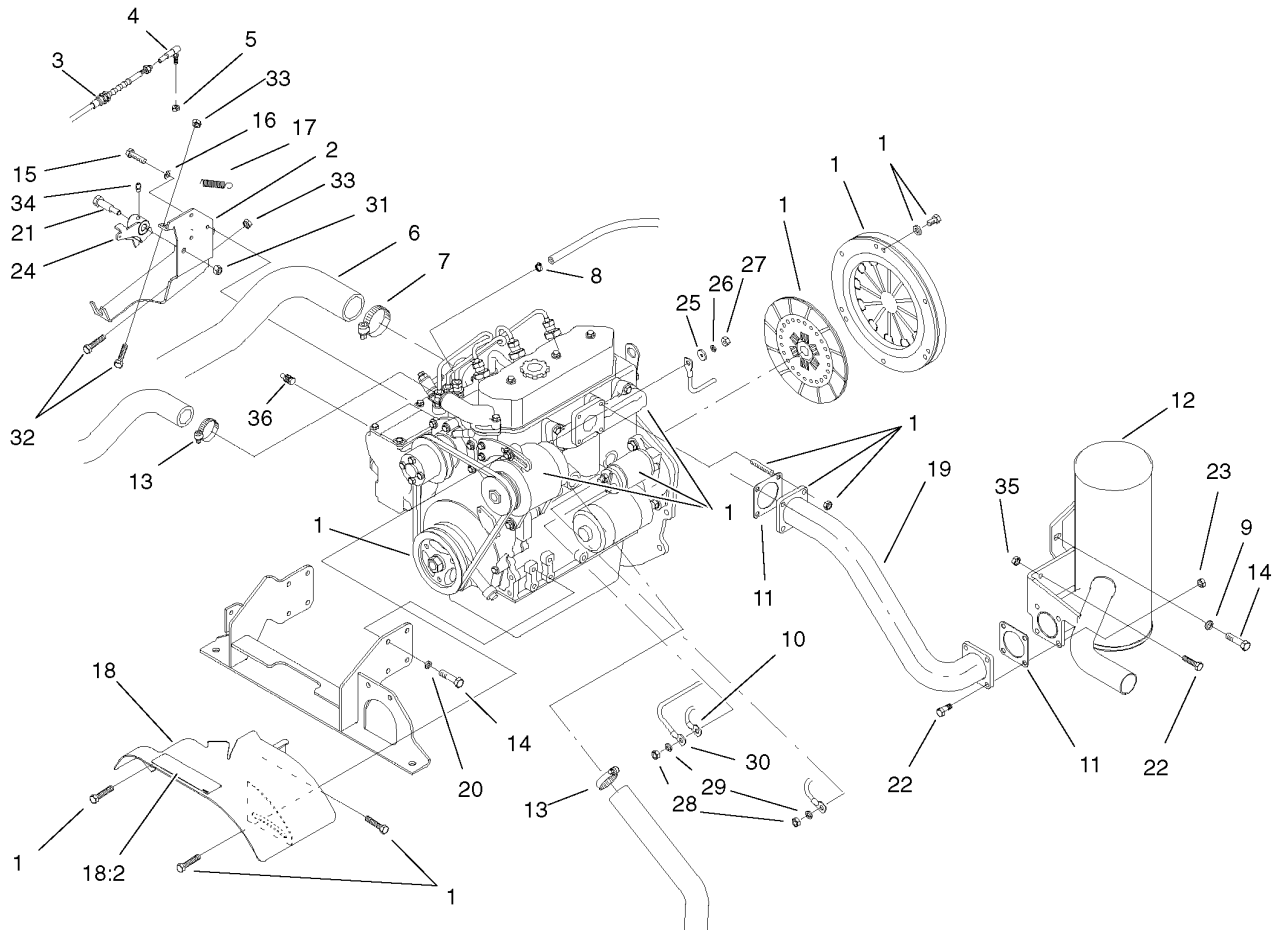

Engine Assembly

Ref	Part No.	Qty.	Description
1	104-9218	1	Engine ASM
2	104-9244-03	1	Bracket-Throttle
3	105-1788	1	Cable-Accelerator
4	18-1720	1	Governor Ball Joint ASM
5	3296-3	1	Nut-Lock
6	105-1700	1	Hose-Air Intake, Gas
7	2412-92	1	Clamp-Hose
8	2412-108	2	Clamp-Worm
9	87-8640	2	Washer-Flat
10	99-3441	1	Harness-Wire, Fusible Link
11	105-4209	2	Gasket-Muffler
12	105-1778	1	Muffler-Exhaust
13	2412-34	2	Clamp-Hose
14	33114-020	9	Screw-HH
15	33103-016	3	Screw-HHF
16	3253-3	3	Washer-Lock
17	87-4020	1	Spring-Extension
18	105-7995	1	Engine Cover ASM
18:2	93-7814	1	Decal-Danger
19	105-4186	1	Exhaust Tube ASM
20	3253-4	8	Washer-Lock
21	7-0030	1	Bolt-Shoulder
22	322-5	6	Screw-HH
23	32128-25	4	Nut-HF

Ref	Part No.	Qty.	Description
24	104-9246-03	1	Plate-Throttle
25	3256-2	1	Washer-Flat
26	43-5920	1	Washer-Lock, Spring
27	48-7880	1	Nut-Hex
28	33014-00	2	Nut-Hex
29	3254-2	2	Washer-Lock, Internal
30	87-3070	1	Cable-Battery, Positive
31	3296-29	1	Nut-Lock, NI
32	321-8	2	Screw-HH
33	3218-1	2	Nut-Jam
34	302-5	1	Fitting-Grease
35	32128-20	2	Nut-HF
36	94-3457	1	Sender-Temperature

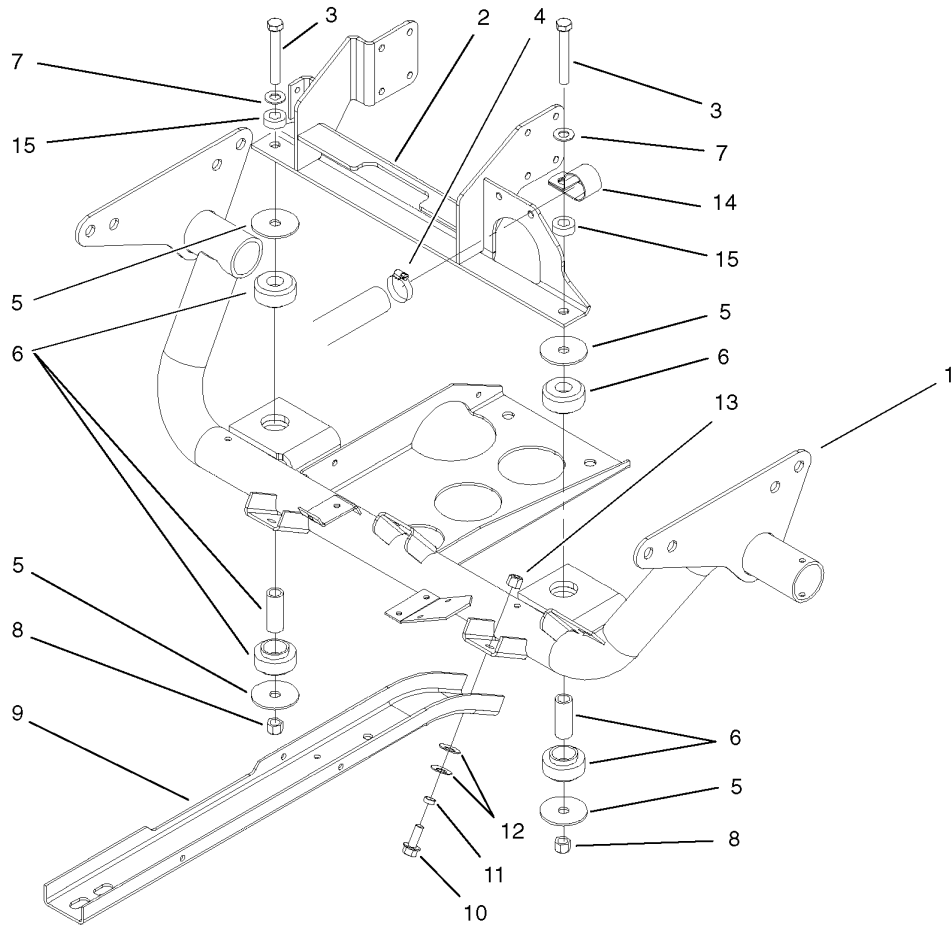

Engine Support Assembly

Ref	Part No.	Qty.	Description
1	105-4200-03	1	Engine Support ASM
2	104-9238-03	1	Engine Mount ASM
3	324-19	2	Screw-HH
4	2412-34	1	Clamp-Hose
5	87-5100	4	Washer-Snubbing
6	87-4970	2	Engine Mount ASM
7	3256-25	2	Washer-Flat
8	3296-48	2	Nut-Lock, NI
9	87-4730-03	2	Guard-Belly
10	3234-11	6	Screw-HHF
11	76-9100	6	Spacer-Speed, Reel
12	3290-413	12	Washer-Belleville
13	3296-39	6	Nut-Lock, NI
14	2412-82	1	Clamp
15	59-2290	2	Spacer

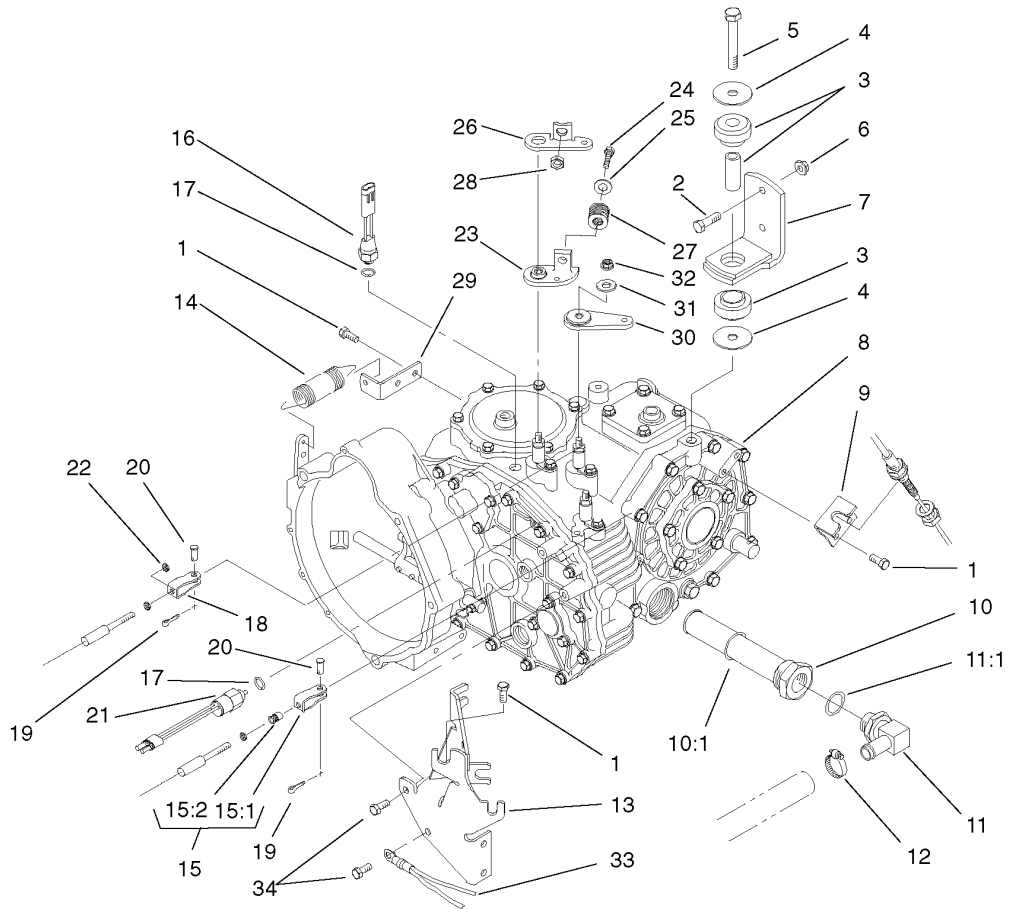

Transaxle Assembly

Ref	Part No.	Qty.	Description
1	33114-020	5	Screw-HH
2	323-7	4	Screw-HH
3	87-4970	2	Engine Mount ASM
4	87-5100	4	Washer-Snubbing
5	3215-1	2	Screw-HH
6	3296-39	4	Nut-Lock, NI
7	87-5800-03	2	Transaxle Mount ASM
8	105-4180	1	2 Wheel Drive Transaxle ASM
9	87-4470	1	Bracket-Lock, Differential
10	87-3990	1	Strainer-Transaxle
10:1	237-123	1	O-Ring
11	353-987	1	Fitting-HYD, 90 DEG
11:1	237-81	1	O-Ring
12	2412-34	1	Clamp-Hose
13	105-4207-03	1	Cable Mount ASM
14	68-9950	1	Spring-Traction
15	87-7160	1	Cable Clevis ASM
15:1	87-2310	1	Clevis-Cable
15:2	32148-15	1	Nut-Insert
16	72-4310	1	Switch-Ball
17	237-30	2	O-Ring
18	87-2310	2	Clevis-Cable
19	3272-6	3	Pin-Cotter
20	283-62	3	Pin-Clevis

Ref	Part No.	Qty.	Description
21	87-6710	1	Switch-Transmission
22	3220-1	2	Nut-Jam
23	87-7970	1	Arm-Shift
24	323-10	1	Screw-HH
25	3256-4	1	Washer-Flat
26	87-8250	1	Plate-Arm, Shift
27	87-6910	1	Spring-Compression
28	32128-21	1	Nut-HF
29	87-7170	1	Bracket-Spring, Clutch
30	87-7960	2	Lever-Shift
31	80-6990	3	Washer-Hardened
32	48-9520	3	Nut
33	87-3080	1	Cable-Battery, Negative
34	33114-025	2	Screw-HH

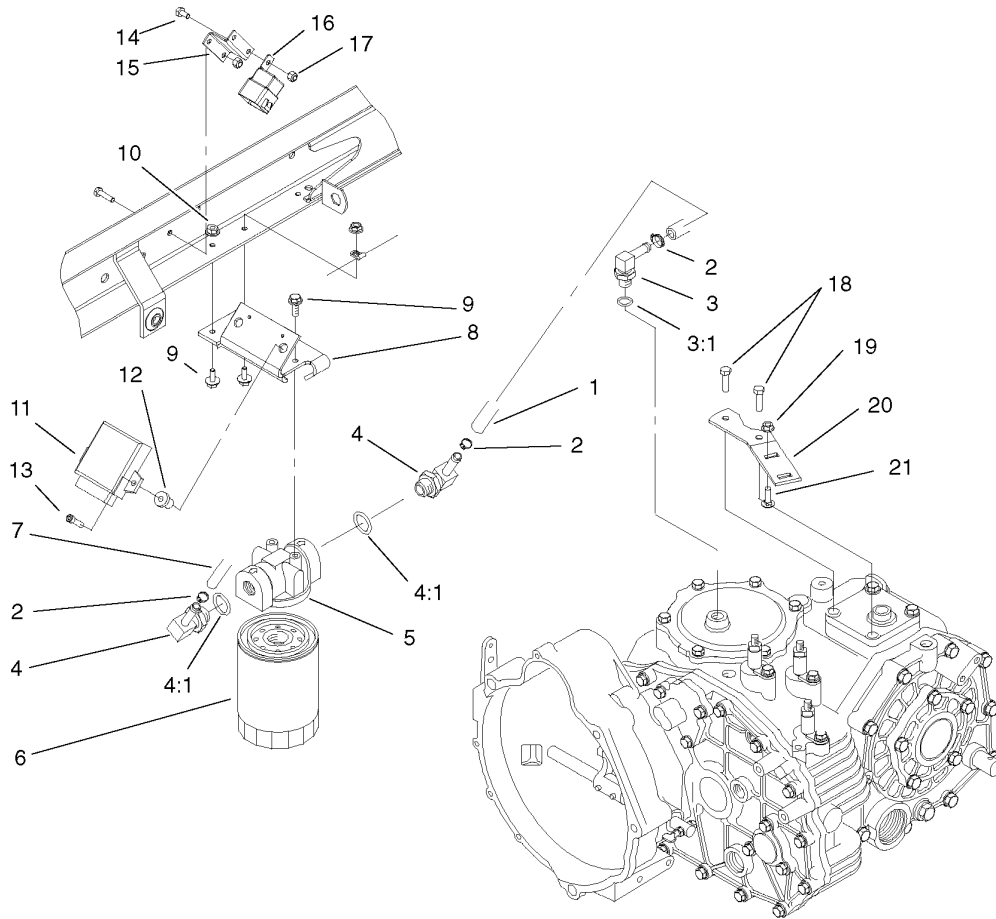

Hydraulic Filter Assembly

Ref	Part No.	Qty.	Description
1	87-5730	1	Hose
2	2412-36	3	Clamp-Hose
3	354-135	1	Fitting-HYD, 90 DEG
3:1	237-42	1	O-Ring
4	354-134	2	Fitting-HYD, 90 DEG
4:1	237-79	1	O-Ring
5	87-8780	1	Head-Filter
6	54-0110	1	Filter-Oil, Transmission
7	94-5255	1	Hose ASM
8	105-4199	1	Bracket-Mount, Filter
9	3234-4	3	Screw-HHF
10	32128-33	1	Nut-HF
11	105-1768	1	Ecm
12	32117-1	2	Nut-Insert
13	3274-9	2	Screw-HSH
14	321-2	2	Screw-HH
15	105-1776	1	Bracket-Mount, Relay
16	99-7430	2	Relay
17	32128-33	2	Nut-HF
18	33114-030	2	Screw-HH
19	32128-20	2	Nut-HF
20	105-9472	1	Plate-Mount, Muffler
21	3230-2	2	Bolt-CARR

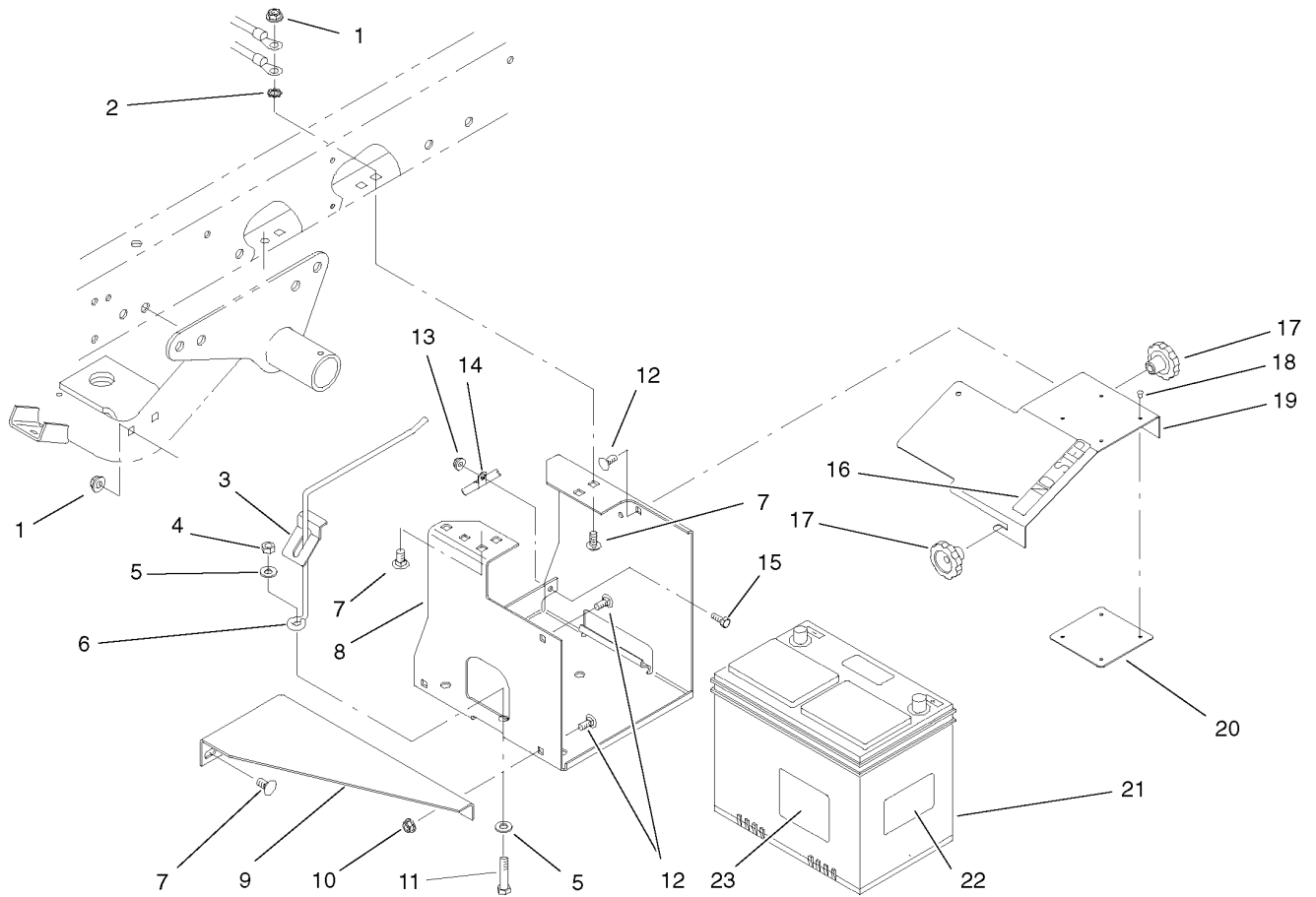

Battery Assembly

Ref	Part No.	Qty.	Description
1	3290-357	6	Nut-HHF, Whiz
2	3255-9	1	Washer-Lock, EXT
3	87-7610	1	Tab-Support, Battery
4	3296-39	1	Nut-Lock, NI
5	3256-24	2	Washer-Flat
6	87-7600	1	Rod-Support, Battery
7	3231-21	6	Screw-CARR
8	87-5120-03	1	Bracket-Holder, Battery
9	87-5110-03	1	Support-Base, Battery
10	32128-20	2	Nut-HF
11	323-9	1	Screw-HH
12	3230-23	4	Screw-CARR
13	32128-33	1	Nut-HF
14	2412-89	1	Clamp
15	321-4	1	Screw-HH
16	93-6687	1	Decal-No Step
17	19-4050	2	Knob
18	3269-27	4	Rivet-Snap
19	87-5130-03	1	Cover-Battery
20	87-7620	1	Shield-Terminal, Battery
21	63-9230	1	Battery-Dry
22	93-7276	1	Decal-Danger
23	93-6668	1	Decal-Battery

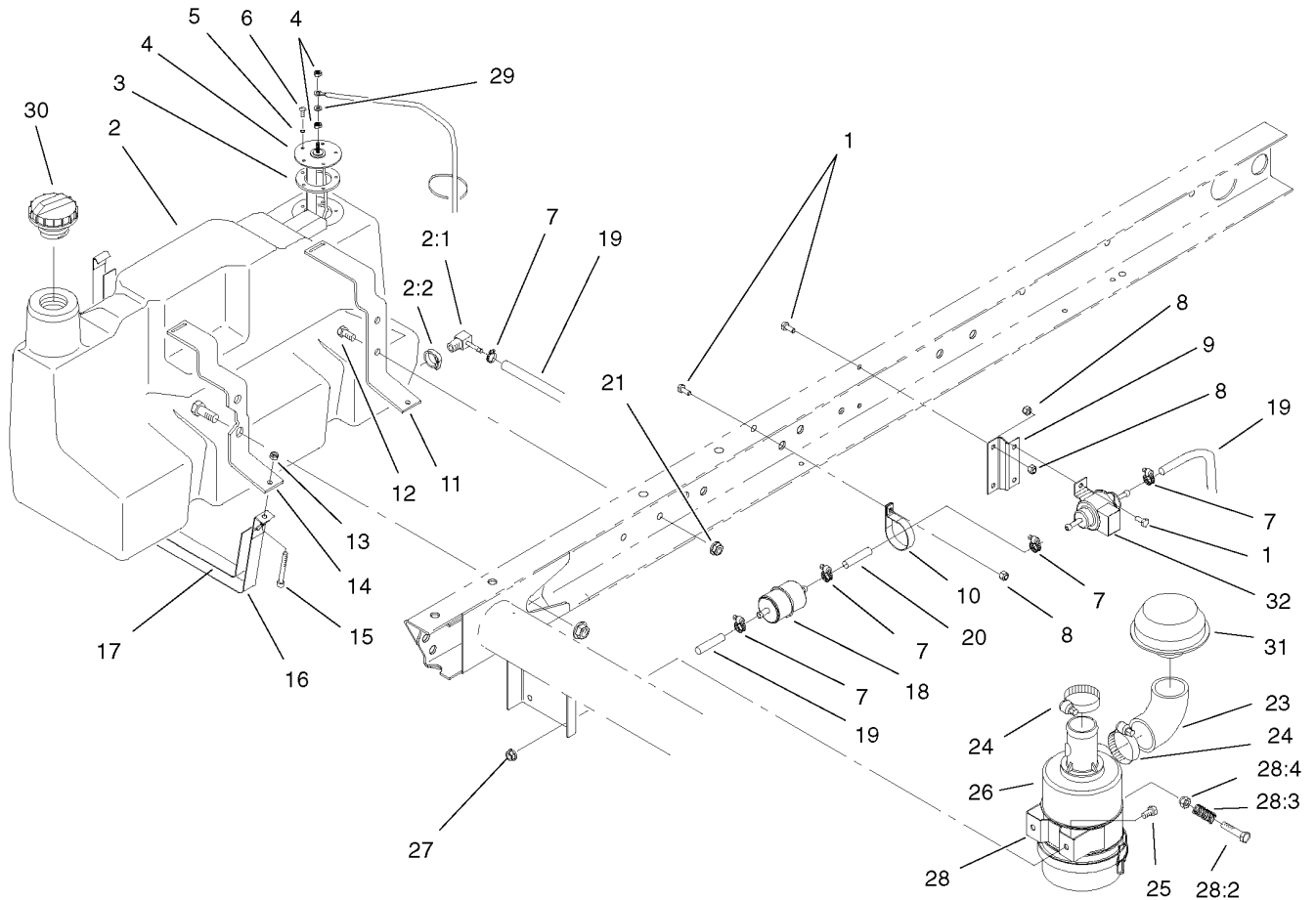

Fuel Tank and Air Cleaner Assembly

Ref	Part No.	Qty.	Description
1	321-3	5	Screw-HH
2	98-2919	1	Tank-Fuel
2:1	353-781	1	Fitting-Elbow
2:2	2412-36	1	Clamp-Hose
3	62-7650	1	Gasket
4	63-7640	1	Sender-Fuel
5	3253-15	5	Washer-Lock
6	32122-24	5	Screw-PTH
7	2412-108	5	Clamp-Worm
8	32128-33	5	Nut-HF
9	105-1774	1	Bracket-Pump, Fuel
10	2412-148	1	Clamp-R
11	87-3140-03	1	Support-Gas Tank, Rear
12	323-4	2	Screw-HH
13	3296-42	2	Nut-Lock, NI
14	87-3150-03	1	Support-Gas Tank, Front
15	3274-54	2	Screw-HSH
16	87-3160	2	Strap-Tank, Gas
17	87-3170	2	Felt-Strap
18	105-8045	1	Filter-Fuel
19	94-1349	2	Hose-Fuel
20	80-7360	1	Hose-Fuel
21	3290-357	2	Nut-HHF, Whiz
23	94-5248	1	Elbow-Intake, Air

Ref	Part No.	Qty.	Description
24	2412-92	2	Clamp-Hose
25	322-2	2	Screw-HH
26	105-7968	1	Air Cleaner ASM
27	32128-20	2	Nut-HF
28	93-2191	1	Band-Mounting, Air Cleaner
28:2	94-3653	1	Bolt
28:3	94-3654	1	Spring
28:4	48-9510	1	Nut
29	5-3637	1	Spacer
30	93-3101	1	Cap-Fuel
31	46-7510	1	Hood-Inlet, Air
32	99-9196	1	Pump-Fuel

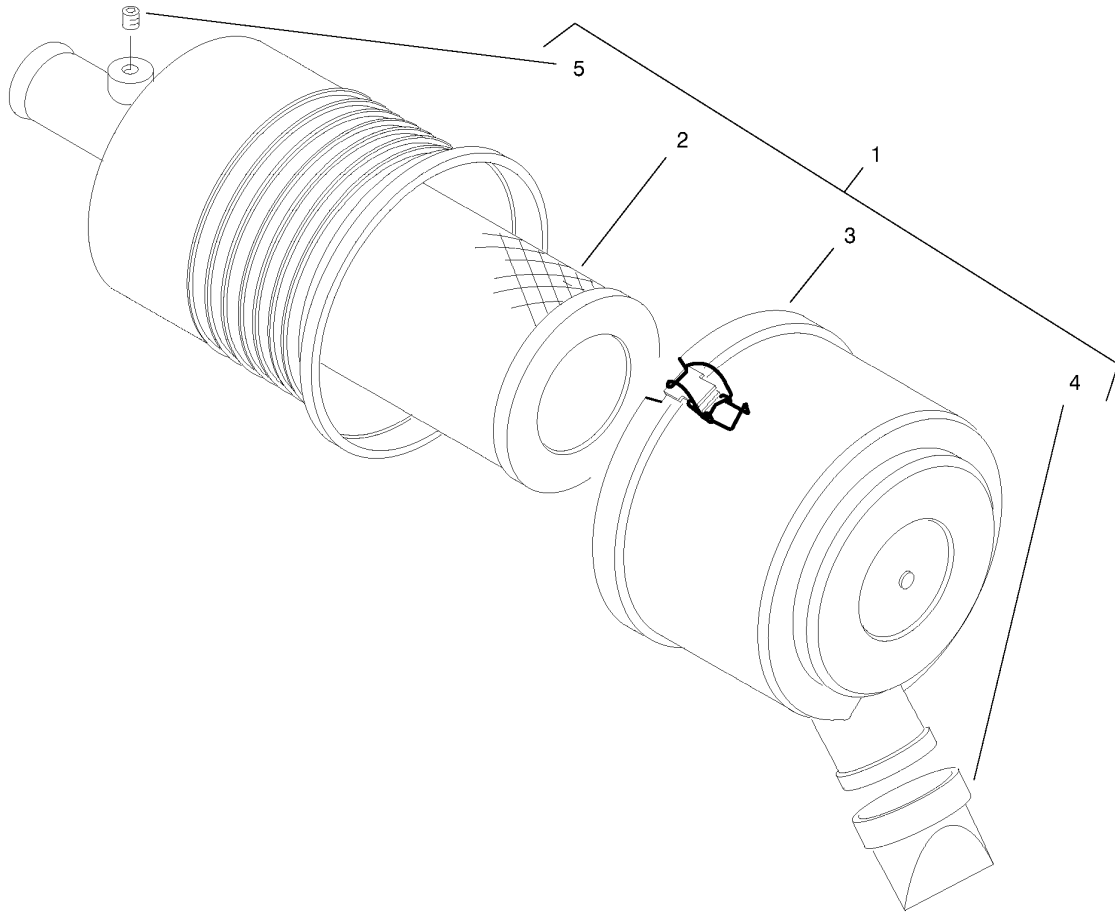

Air Cleaner Assembly No. 105-7968

Ref	Part No.	Qty.	Description
1		1	Air Cleaner ASM
2	93-2195	1	Filter
3	94-3652	1	Cover ASM
4	94-1414	1	Valve-Vacuator
5	285-17	1	Plug-Pipe

--	--	--	--

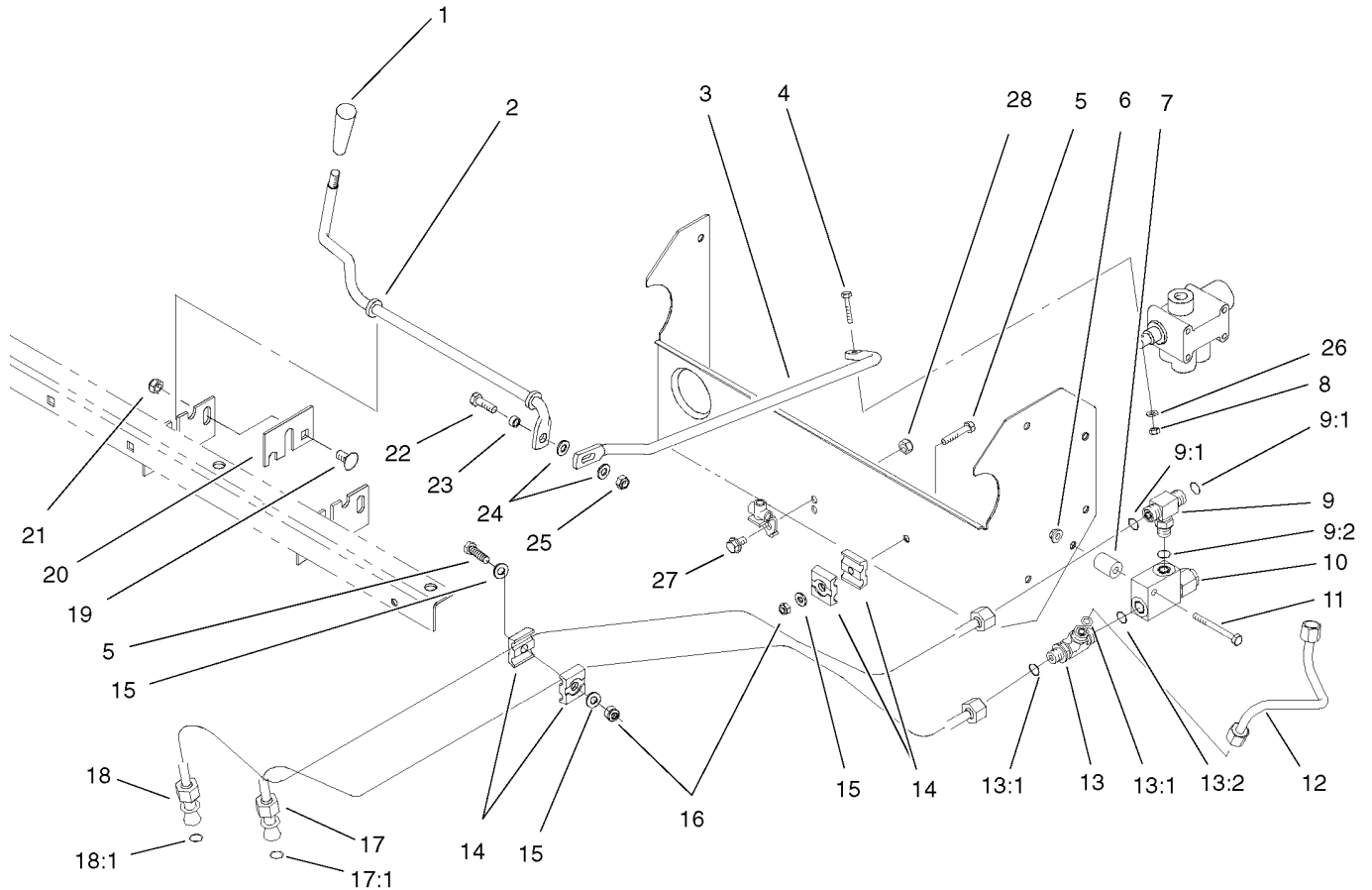

Lift Valve Linkage Assembly

Ref	Part No.	Qty.	Description
1	233-39	1	Knob-Control
2	87-4500	1	Rod-Pivot, Pump
3	87-4510	1	Rod-Connecting Dump
4	87-5150	1	Bolt
5	321-9	2	Screw-HH
6	32128-33	1	Nut-HF
7	75-9610	1	Support-Radiator
8	87-5140	1	Nut-Lock
9	340-94	1	Adapter
9:1	237-22	2	O-Ring
9:2	237-42	1	O-Ring
10	87-3680	1	Valve-Relief
11	321-15	1	Screw-HH
12	92-2622	1	Hardline-Rel/Remote
13	340-86	1	Fitting-HYD, Tee
13:1	237-22	2	O-Ring
13:2	237-42	1	O-Ring
14	56-7973	4	Clamp-Tube
15	3256-22	3	Washer-Flat
16	3296-42	2	Nut-Lock, NI
17	87-9350	1	Hardline-Steering
17:1	39-7310	1	Seal-O Ring
18	87-4540	1	Hardline-Steering
18:1	39-7310	1	Seal-O Ring

Ref	Part No.	Qty.	Description
19	3231-21	2	Screw-CARR
20	87-4490	2	Bracket-Hold Down
21	3296-39	2	Nut-Lock, NI
22	322-5	1	Screw-HH
23	87-5080	1	Spacer-Rod, Connecting
24	3256-23	2	Washer-Flat
25	3296-29	1	Nut-Lock, NI
26	3256-14	1	Washer-Flat
27	322-2	1	Screw-HH
28	32128-20	1	Nut-HF

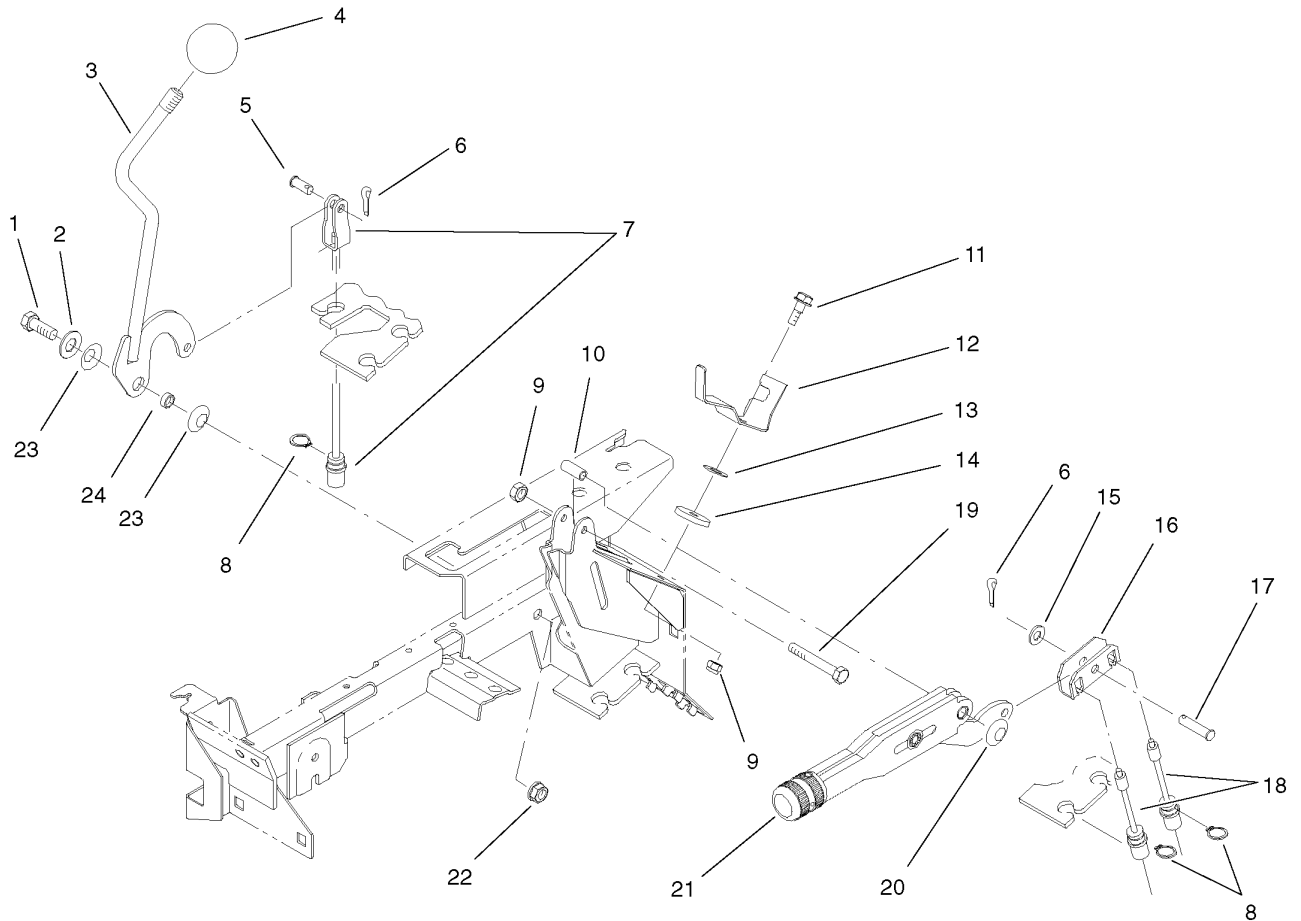

Differential Lock and Parking Brake Assembly

Ref	Part No.	Qty.	Description
1	323-6	1	Screw-HH
2	49-9150	1	Washer-Pivot
3	87-5030	1	Lever-Lock, Differential
4	233-48	1	Knob
5	283-62	1	Pin-Clevis
6	3272-6	2	Pin-Cotter
7	87-4460	1	Cable-Lock, Differential
8	32120-47	3	Ring-Retaining, External
9	3296-42	2	Nut-Lock, NI
10	87-4710	1	Spacer-Brake, Parking
11	42-3560	1	Bolt-Shoulder
12	87-6640-03	1	Lever-Dump Stop
13	3290-478	1	Washer-Belleville
14	71-5320	1	Washer-Support, Engine
15	3256-23	1	Washer-Flat
16	87-3480	1	Bracket-Equalizer, Cable
17	94-3829	1	Pin-Clevis
18	87-8240	2	Cable-Brake
19	321-9	1	Screw-HH
20	3290-477	1	Washer-Curved
21	87-2710	1	Lever-Brake
22	3296-39	1	Nut-Lock, NI
23	3290-221	2	Washer-Spring
24	76-2290	1	Spacer

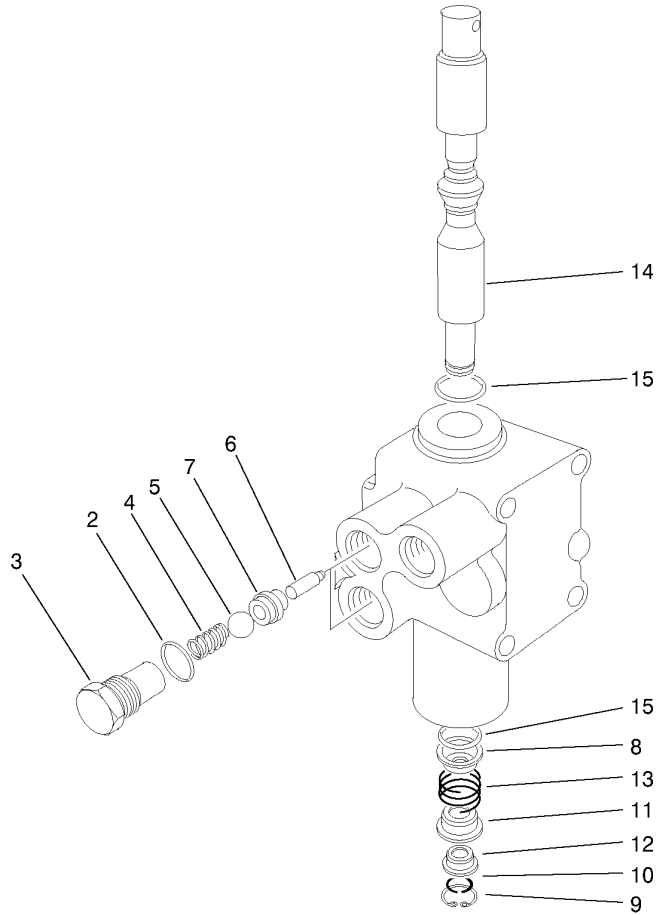

Hydraulic Valve Assembly No. 43-1710-01

Ref	Part No.	Qty.	Description
2	237-42	2	O-Ring
3	22-8330	2	Plug
4	22-8340	2	Spring
5	22-8350	2	Ball
6	22-8360	2	Pin
7	22-8370	2	Seat-Valve
8	22-8380	1	Retainer
9	22-8490	1	Ring-Snap
10	22-8480	1	Ring-Snap
11	22-8390	1	Retainer
12	22-8400	1	Spacer
13	22-8410	1	Spring
14	22-8420	1	Spool
15	22-8500	2	O-Ring

--	--	--	--

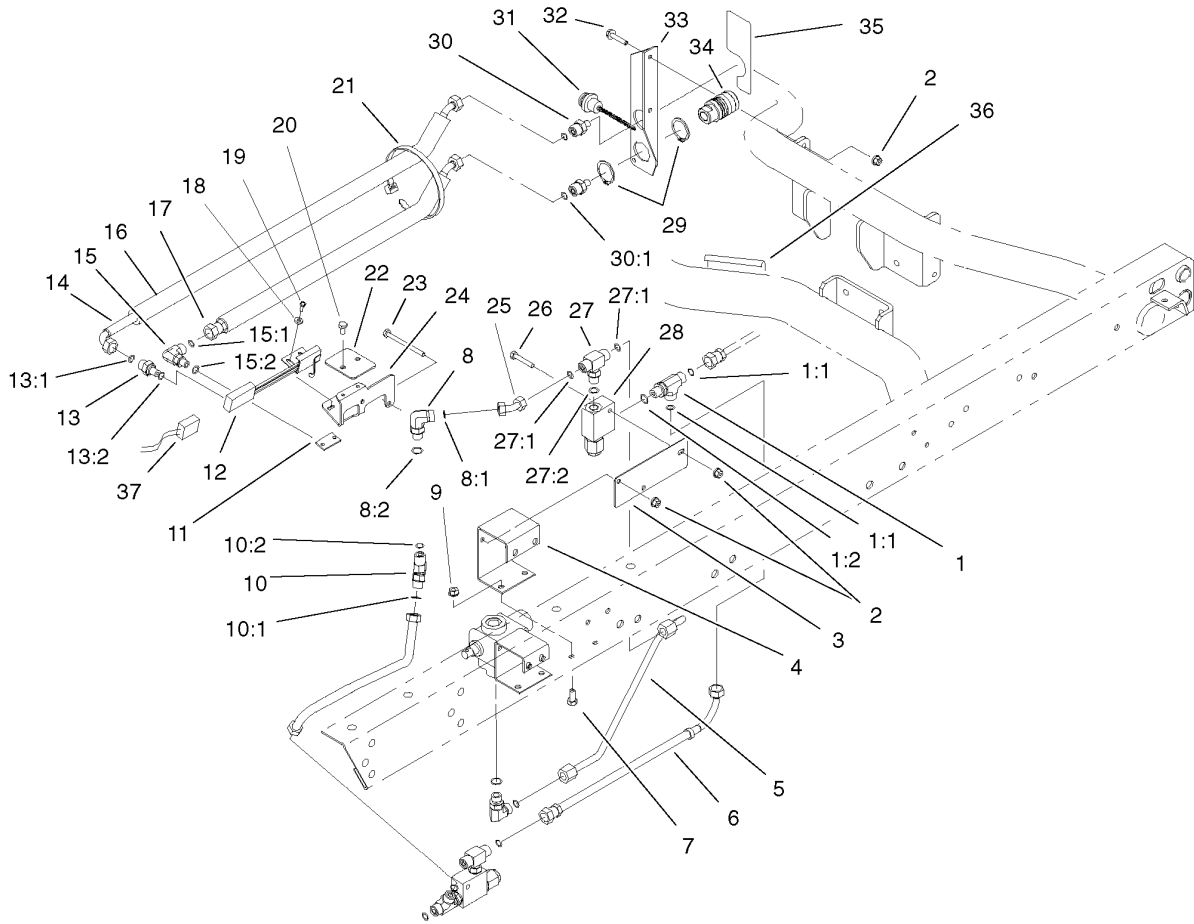

Remote Hydraulics

Ref	Part No.	Qty.	Description
1	340-86	1	Fitting-HYD, Tee
1:1	237-22	2	O-Ring
1:2	237-42	1	O-Ring
2	32128-33	5	Nut-HF
3	92-2623-03	1	Plate-Valve, Relief
4	87-4620-03	1	Bracket-Valve, Aux
5	93-9535	1	Hardline-Dump / Remote
6	92-2624	1	Hose ASM
7	322-3	4	Screw-HH
8	340-77	1	Fitting-HYD, 90 DEG
8:1	237-22	1	O-Ring
8:2	237-42	1	O-Ring
9	32128-20	4	Nut-HF
10	340-87	1	Fitting-HYD, 45 DEG
10:1	237-22	1	O-Ring
10:2	237-42	1	O-Ring
11	93-9539	1	Strip-Tapped
12	92-7905	1	Switch And Bracket ASM
13	340-88	1	Adapter
13:1	237-22	1	O-Ring
13:2	237-78	1	O-Ring
14	92-2606	1	Hose ASM
15	340-97	1	Fitting-HYD, 90 DEG
15:1	237-22	1	O-Ring

Ref	Part No.	Qty.	Description
15:2	237-78	1	O-Ring
16	93-9540	2	Sleeve-Protective
17	92-2605	1	Hose ASM
18	3256-14	2	Washer-Flat
19	32105-8	2	Screw-SHH
20	321-2	2	Screw-HH
21	3290-378	6	Tie-Cable
22	93-9538	1	Cover-Switch, Aux HYD
23	321-23	2	Screw-HH
24	93-9537	1	Bracket-Mounting, Switch
25	92-2620	1	Hardline-Rel / Remote
26	321-9	1	Screw-HH
27	340-94	1	Adapter
27:1	237-22	2	O-Ring
27:2	237-42	1	O-Ring
28	92-2625	1	Valve-Relief
29	92-2601	4	Ring-Retaining
30	340-12	2	Fitting-Straight
30:1	237-30	1	O-Ring
31	92-2603	2	Plug-Dust
32	3234-21	2	Screw-Cap
33	92-2604-03	1	Bracket-Coupler
34	92-2602	2	Coupling-HYD, Female
35	93-9089	1	Decal-Quick Couplers

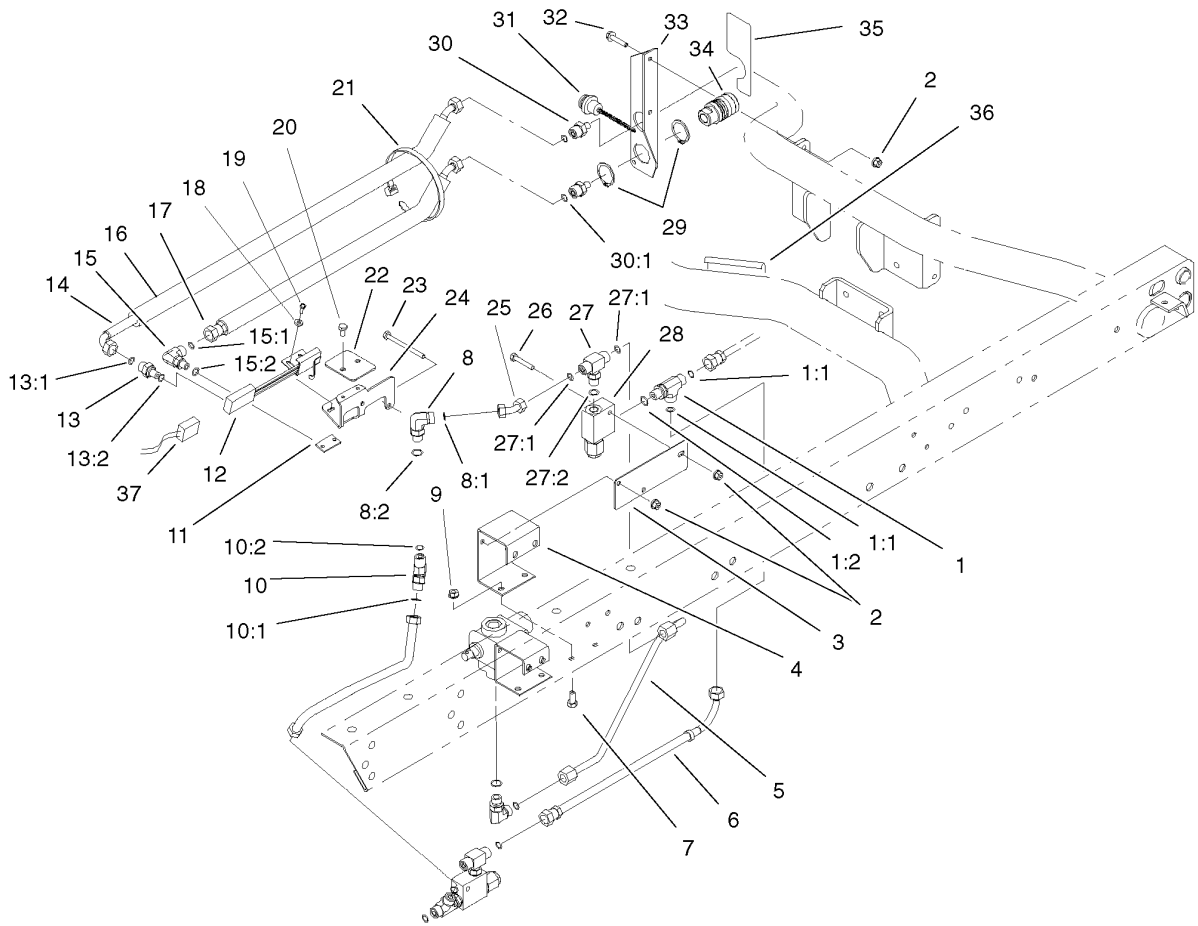

Remote Hydraulics (continued)

Ref	Part No.	Qty.	Description
36	93-9090	1	Decal-Caution
37	93-9541	1	Wire Harness-Aux HYD

--	--	--	--

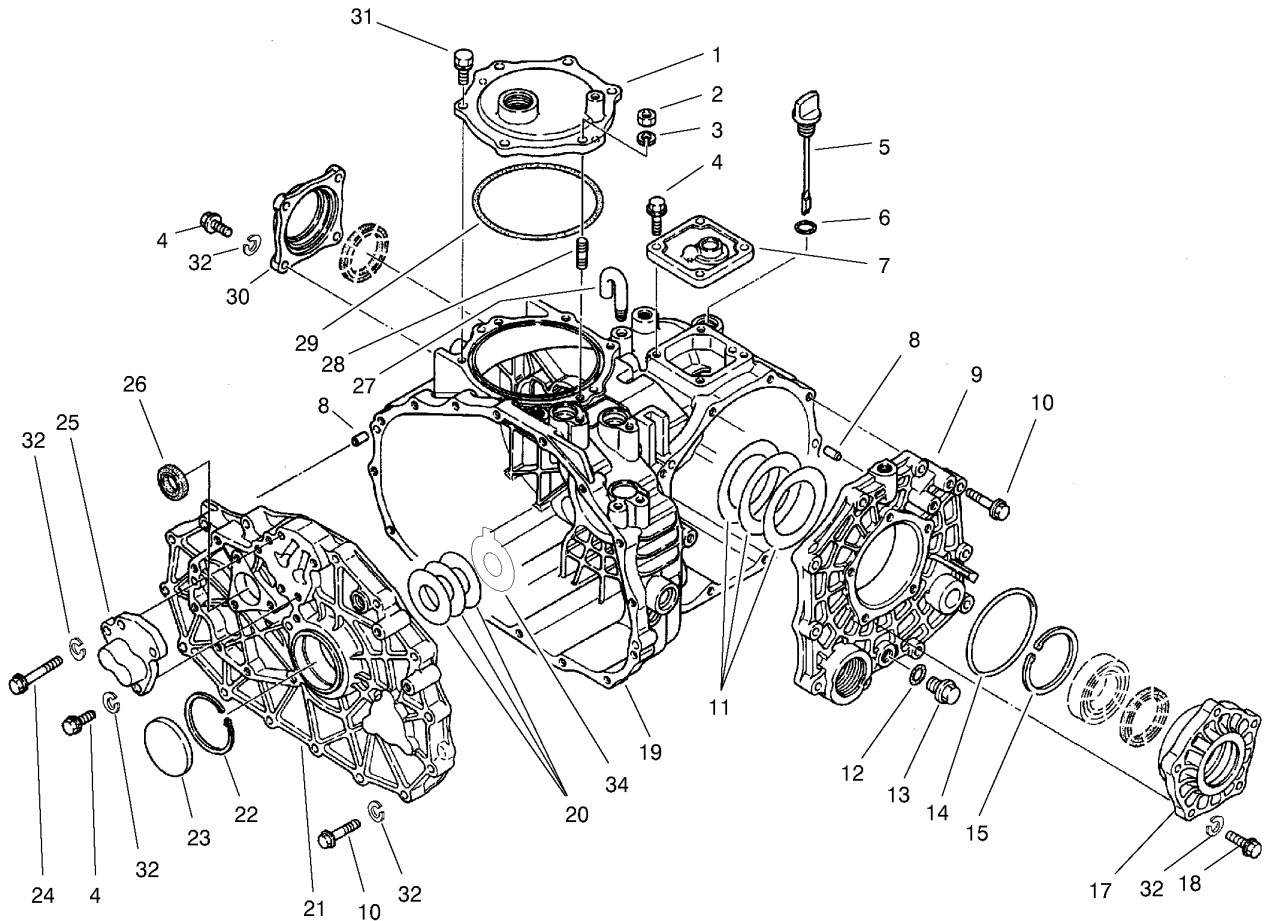

Transaxle Case Assembly No. 105-4180

Ref	Part No.	Qty.	Description
1	92-0656	1	Cover-Upper, PTO
2	48-7930	1	Nut
3	92-0762	1	Washer-Spring
4	60-6750	11	Bolt
5	92-0662	1	Cap-Oil
6	92-0788	1	O-Ring
7	92-0652	1	Cover-Upper
8	92-0765	4	Pin-Parallel
9	92-0653	1	Cover-Side
10	42-9530	25	Bolt/Washer
11	92-0809	1	Set-Shim
12	92-0787	1	O-Ring
13	92-0773	1	Plug-Drain
14	92-0789	1	O-Ring
15	92-0760	1	Ring-Snap
17	92-0654	1	Carrier-Differential
18	48-7730	5	Screw-HH
19	92-0651	1	Case-Transmission
20	100-4460	1	Shim Set
21	100-4461	1	Plate-Center
22	92-0759	1	Ring-Snap
23	92-0807	1	Cap-Sealing
24	48-7560	1	Bolt-HH
25	92-0706	1	Shaft-Fork

Ref	Part No.	Qty.	Description
26	92-0791	1	Seal-Oil
27	92-0743	1	Breather-Air
28	92-0804	1	Stud
29	92-0790	1	O-Ring
30	92-0655	1	Cover-Seal, Axle
31	92-0796	5	Bolt
32	42-9850	42	Washer-Lock, Spring
34	100-4465	1	Shim (W/Tab)

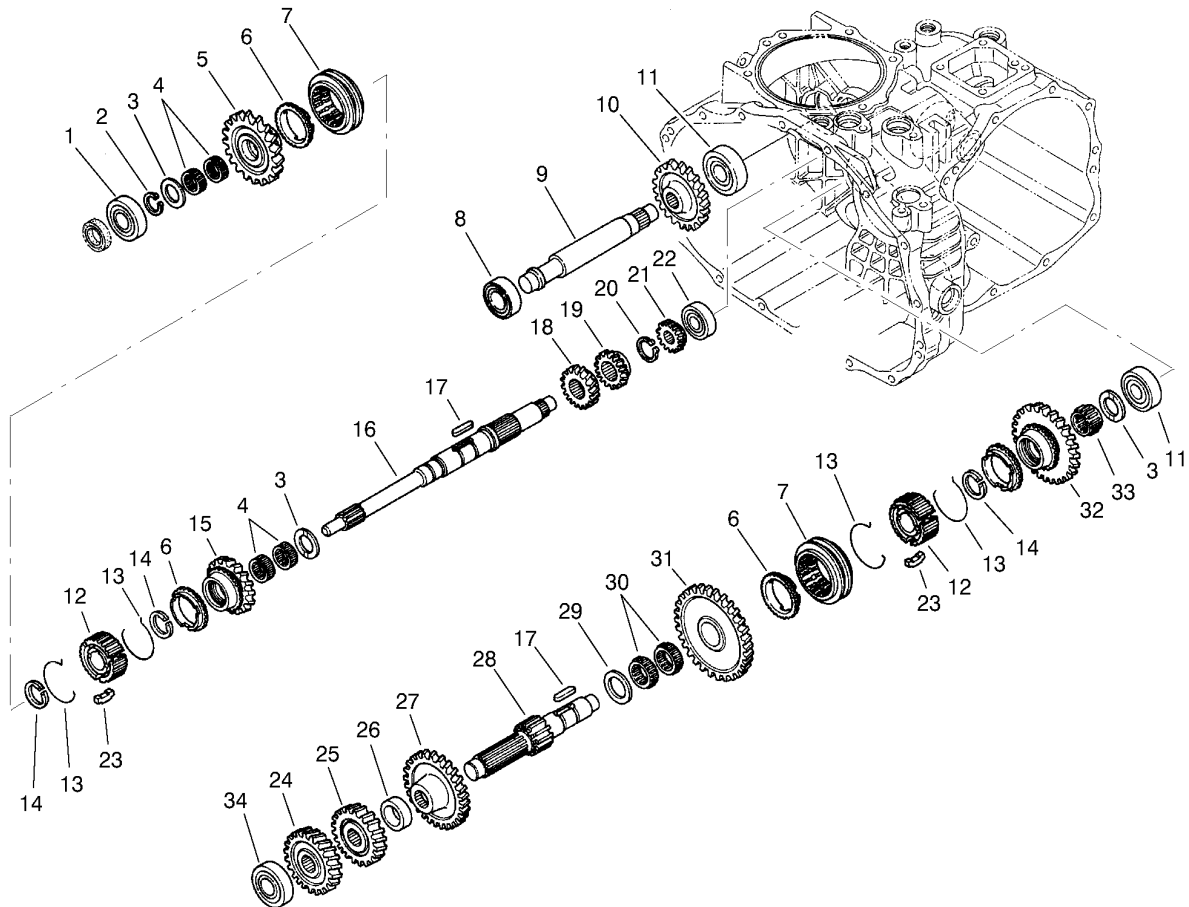

Transaxle Gear Shaft Assembly No. 105-4180

Ref	Part No.	Qty.	Description
1	251-8	1	Bearing-Ball
2	92-0753	1	Ring-Snap
3	92-0740	3	Washer-Thrust
4	92-0781	4	Bearing-Needle
5	92-0820	1	Gear-Main, 27 Tooth
6	92-0667	3	Ring-Synchro
7	92-0668	2	Shifter-Synchro
8	251-346	2	Bearing-Ball
9	92-0824	1	Shaft-Idler, Reverse
10	92-0684	1	Gear-Reverse, 33 Tooth
11	92-0778	2	Bearing
12	92-0664	2	Hub-Synchro
13	92-0666	4	Spring-Synchro
14	92-0763	3	Ring-Snap
15	92-0821	1	Gear-Main, 24 Tooth
16	92-0663	1	Shaft-Main
17	92-0772	2	Key
18	92-0687	1	Gear-Main, 16 Tooth
19	92-0672	1	Gear-Main, 18 Tooth
20	92-0754	1	Ring-Snap
21	92-0673	1	Gear-Main, 14 Tooth
22	92-0650	1	Bearing
23	92-0665	6	Key-Synchro
24	92-0822	1	Gear-Reduction, 28 Tooth

Ref	Part No.	Qty.	Description
25	92-0679	1	Gear-Reduction, H23 Tooth
26	92-0680	1	Collar
27	92-0823	1	Gear-Reduction, 43 Tooth
28	92-0674	1	Shaft-Reduction
29	92-0682	1	Washer-Thrust
30	92-0681	2	Bearing-Needle
31	92-0677	1	Gear-Reduction, 49 Tooth
32	92-0819	1	Gear-Reduction, 40 Tooth
33	92-0782	1	Bearing-Needle
34	105-7985	1	Bearing

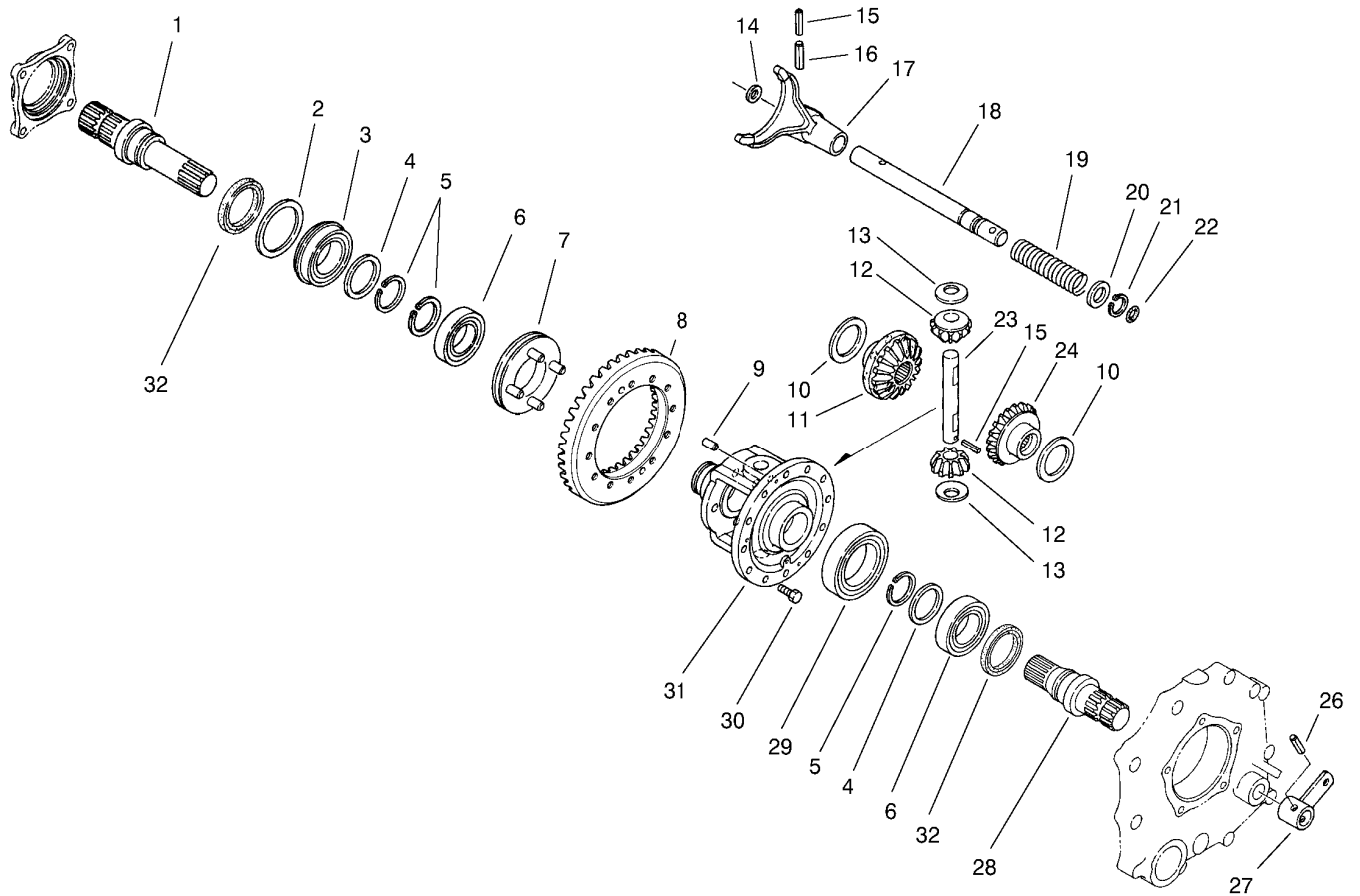

Differential Gear Assembly No. 105-4180

Ref	Part No.	Qty.	Description
1	92-0726	1	Shaft-Axle, Right
2	92-0728	1	Washer
3	92-0780	1	Bearing
4	92-0727	2	Washer
5	92-0756	3	Ring-Snap
6	92-0775	2	Bearing
7	92-0730	1	Slider-Differential, Lock
8	105-7983	1	Countershaft And Ring Gear
9	92-0765	2	Pin-Parallel
10	92-0747	2	Side-Gear, Left Inner
11	92-0746	1	Gear-Side, RH
12	92-0748	2	Pinion-Differential
13	92-0750	2	Washer
14	92-0744	1	Washer
15	92-0768	2	Pin-Roll, Spring
16	92-0771	1	Pin-Roll, Spring
17	92-0721	1	Fork-Lock, Differential
18	92-0722	1	Shaft-Fork, Lock Differential
19	92-0723	1	Spring-Lock, Differential
20	92-0733	1	Washer
21	92-0753	1	Ring-Snap
22	92-0787	1	O-Ring
23	92-0749	1	Shaft-Pinion
24	92-0745	1	Gear-Side, LH

Ref	Part No.	Qty.	Description
26	92-0770	1	Pin-Roll, Spring
27	92-0724	1	Arm-Lock, Differential
28	92-0725	1	Shaft-Axle, Left
29	92-0776	1	Bearing
30	92-0803	12	Bolt
31	92-0720	1	Case-Differential
32	92-0793	2	Seal-Oil

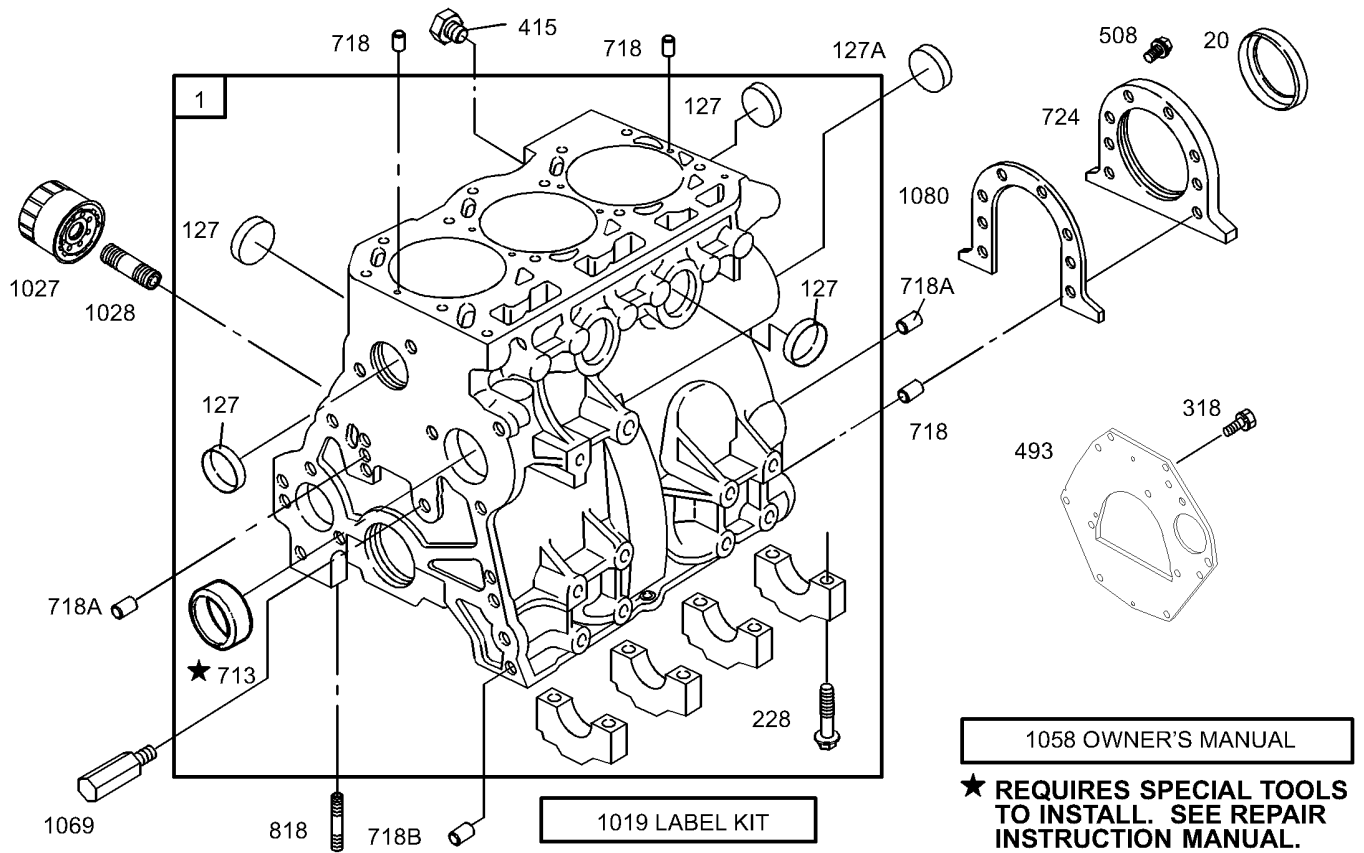

Assemblies include all parts shown in frames.

Cylinder Assembly

Ref	Part No.	Qty.	Description
1	112-2982	1	Cylinder ASM
20	99-9003	1	Seal-Oil
127	99-9008	1	Plug-Welch
228	99-9006	1	Screw-Hex
318	99-9005	1	Screw-Hex
415	99-9010	1	Plug-Welch
493	104-9232	1	Plate-End, Rear
508	99-9004	1	Screw-Hex
713	99-9002	1	Bushing
718	99-9012	1	Pin-Locating
724	99-9022	1	Retainer-Seal
818	99-9007	1	Stud-Metric
1019	110-2595	1	Label Kit
1027	108-3842	1	Filter-Oil
1028	105-9337	1	Adapter-Filter, Oil
1058	99-9019	1	Manual-Owners, Engine
1069	99-9020	1	Nozzle-Oil
1080	99-9021	1	Gasket-Retainer
127A	107-9892	1	Plug-Welch (Cam)
718A	99-9013	1	Pin-Locating
718B	99-9014	1	Pin-Locating

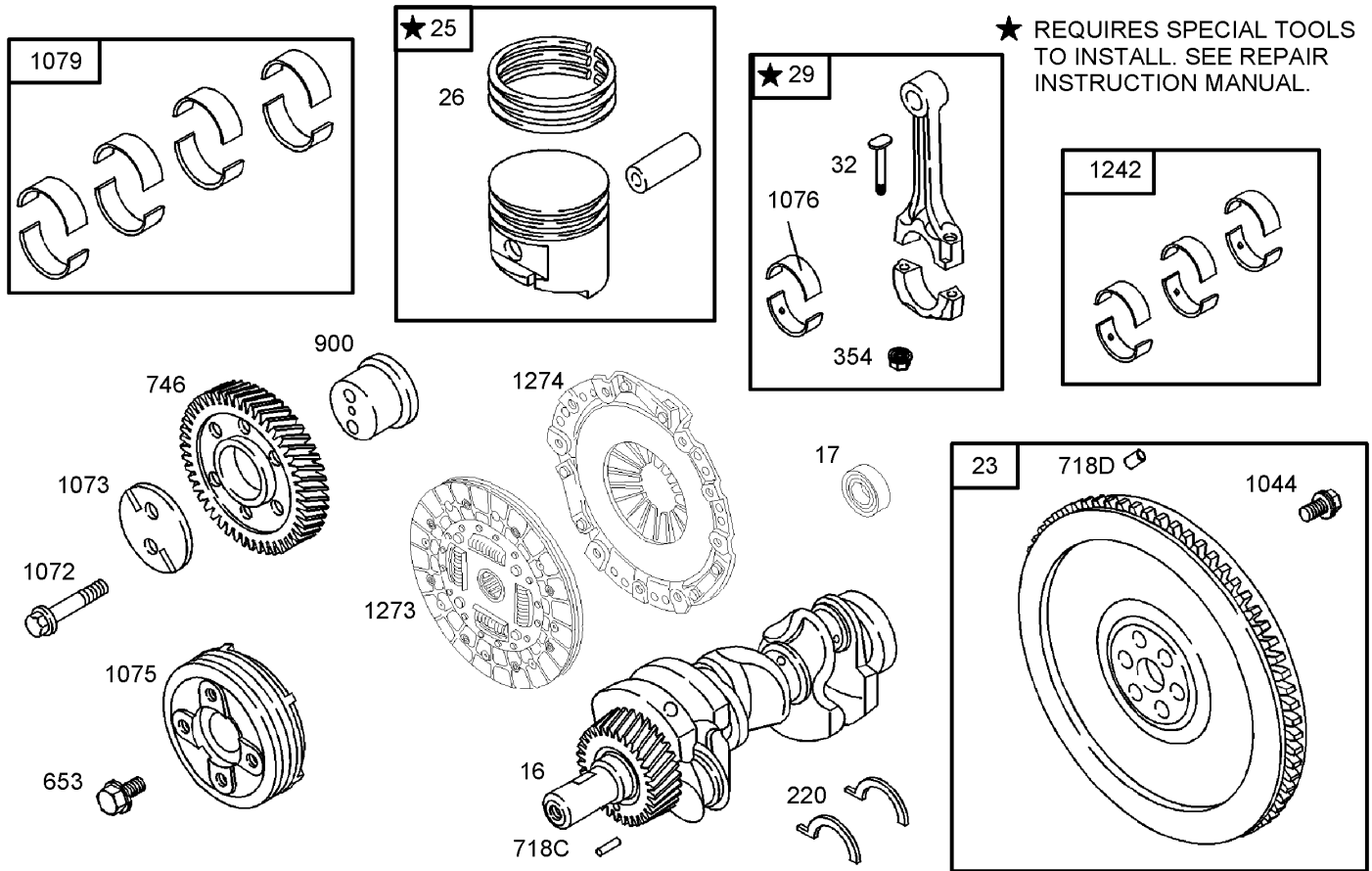

Assemblies include all parts shown in frames.

Crankshaft Assembly

Ref	Part No.	Qty.	Description
16	105-9339	1	Crankshaft
17	105-9324	1	Bearing-Ball, Radial
23	105-9323	1	Flywheel ASM
25	99-9025	1	Piston ASM (Standard)
25	99-9026	1	Piston ASM (.010 Over)
26	99-9027	1	Ring Set (Standard)
26	99-9028	1	Ring Set (.010 Over)
29	99-9029	1	Rod-Connecting
32	99-9030	1	Screw-Rod, Connecting
220	99-9035	1	Washer-Thrust
220	99-9036	1	Washer-Thrust (.005 In Oversized)
354	99-9034	1	Nut-Hex
653	107-9897	1	Screw-Hex
746	99-9609	1	Gear-Drive
900	99-9039	1	Shaft-Gear
1044	99-9031	1	Screw-Hex
1072	99-9032	1	Screw-Hex
1073	99-9040	1	Plate-Gear, Idler
1075	99-9041	1	Pulley-Crankshaft
1076	99-9042	1	Bearing-Rod
1079	99-9045	1	Set-Bearing, Main (Set Of 8)
1079	99-9046	1	Set-Bearing, Main (.010 Undersized)

Ref	Part No.	Qty.	Description
1242	99-9043	1	Set-Bearing, Rod
1242	99-9044	1	Set-Bearing, Rod (.010 Undersized)
1273	104-9219	1	Disc-Clutch
1274	104-9231	1	Plate-Pressure, Clutch
718C	99-9037	1	Pin-Locating
718D	106-1852	1	Pin-Locating

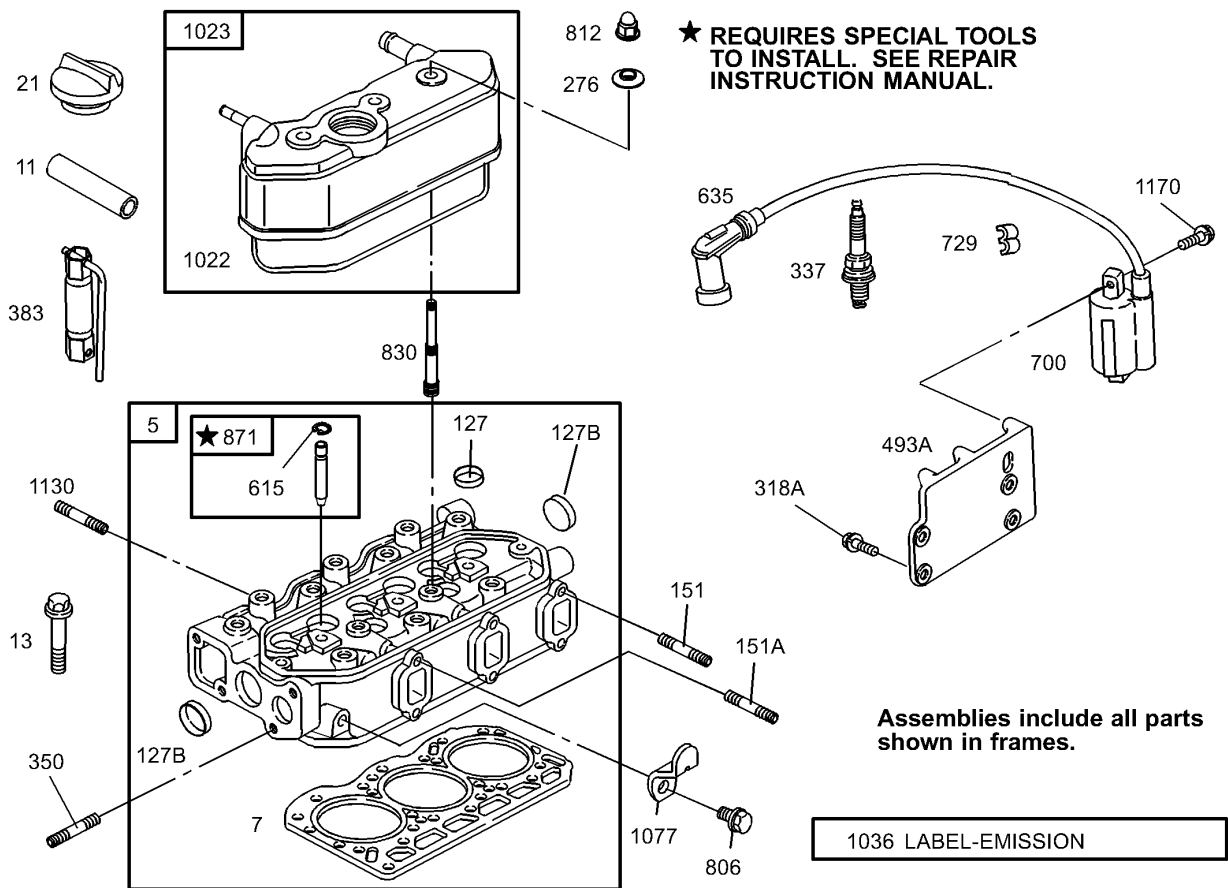

Cylinder Head Assembly

Ref	Part No.	Qty.	Description
5	106-1853	1	Head-Cylinder
7	99-9254	1	Gasket-Head, Cylinder
11	105-9322	1	Hose-Breather
13	99-9614	1	Screw-Metric
21	99-9052	1	Cap-Fill, Oil
127	99-9060	1	Plug-Welch
151	99-9058	1	Stud-Metric
276	99-9063	1	Washer-Seal
337	108-6945	1	Plug-Spark
350	99-9057	1	Stud-Metric
383	94-1664	1	Wrench-Spark Plug
615	99-9067	1	Retainer
635	99-9068	1	Boot-Plug, Spark
700	99-9069	1	Coil-Ignition
729	99-9066	1	Clip-Wire
806	99-9270	1	Screw-Hex
812	99-9061	1	Nut-Hex, Metric
830	99-9101	1	Stud-Arm, Rocker
871	99-9070	1	Bushing-Guide
1022	99-9073	1	Gasket-Cover, Rocker
1023	99-9074	1	Cover-Rocker
1036	99-9075	1	Emission Label Kit
1077	99-9076	1	Bracket-Lifting
1130	99-9055	1	Stud-Metric

Ref	Part No.	Qty.	Description
1170	99-9056	1	Screw-Hex
127B	99-9008	1	Plug-Welch
151A	99-9059	1	Stud-Metric
318A	99-9202	1	Screw-Hex
493A	99-9065	1	Bracket-Mounting

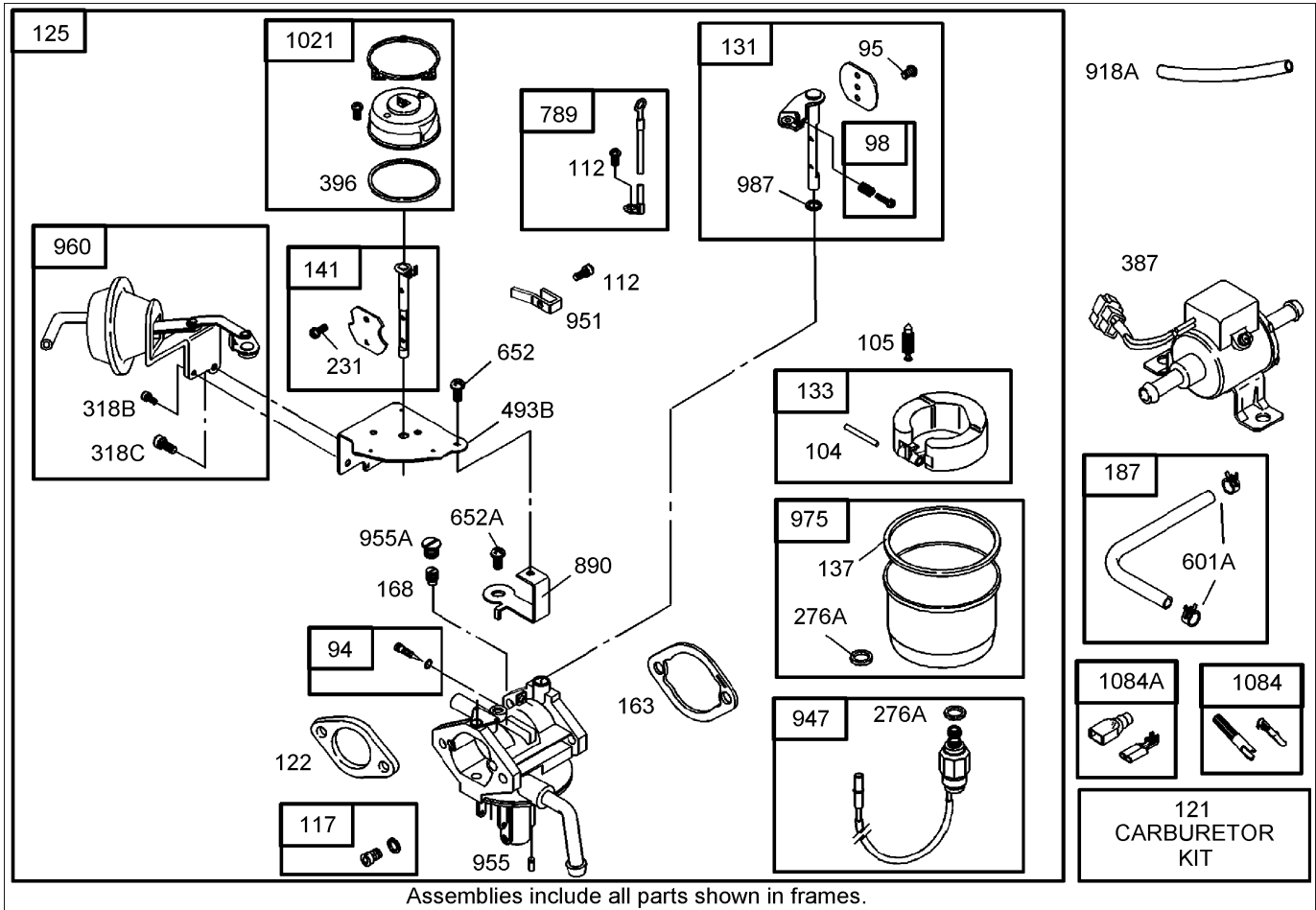

Carburetor Assembly

Ref	Part No.	Qty.	Description
94	106-1856	1	Idle Mixture Kit
95	106-1857	1	Screw
98	106-1858	1	Idle Speed Kit
104	106-1859	1	Pin-Hinge, Float
105	106-1860	1	Valve-Needle, Float
112	105-2063	2	Screw-Mtg., Valve
117	110-2564	1	Jet-Main
121	110-2565	1	Carburetor Kit
122	99-9184	1	Spacer-Carburator
125	110-2563	1	Carburetor Assembly
131	110-2566	1	Throttle Shaft Kit
133	106-1864	1	Float-Carburetor
137	106-1865	1	Gasket-Bowl, Float
141	106-1866	1	Choke Shaft Kit
163	105-9329	1	Gasket-Funnel, Air
168	106-1953	1	Jet-Circuit, Idle
187	99-9238	1	Line-Fuel
231	106-1857	1	Screw
387	99-9196	1	Pump-Fuel
396	106-1871	1	Gasket-Cover, Choke
652	106-1869	1	Screw
789	106-1875	1	Harness-Wiring
890	106-1876	1	Bracket-Support
947	110-2511	1	Solenoid-Valve

Ref	Part No.	Qty.	Description
951	106-1878	1	Lever-Choke
955	106-1879	1	Plug-Carburetor
960	106-1881	1	Break-Choke, Vacuum
975	106-1882	1	Bowl-Float
997		1	Seal-Shaft, Throttle
1021	106-1883	1	Activator-Choke
1084	99-9245	1	Connector
276A	106-1868	1	Washer-Sealing
318B	106-1869	1	Screw
318C	106-1870	1	Screw
493B	106-1872	1	Bracket-Mounting
601A	99-9242	1	Clamp-Hose
652A	106-1874	1	Screw
918A	105-9330	1	Hose-Vacuum
955A	106-1880	1	Plug-Carburetor
1084A	99-9098	1	Connector

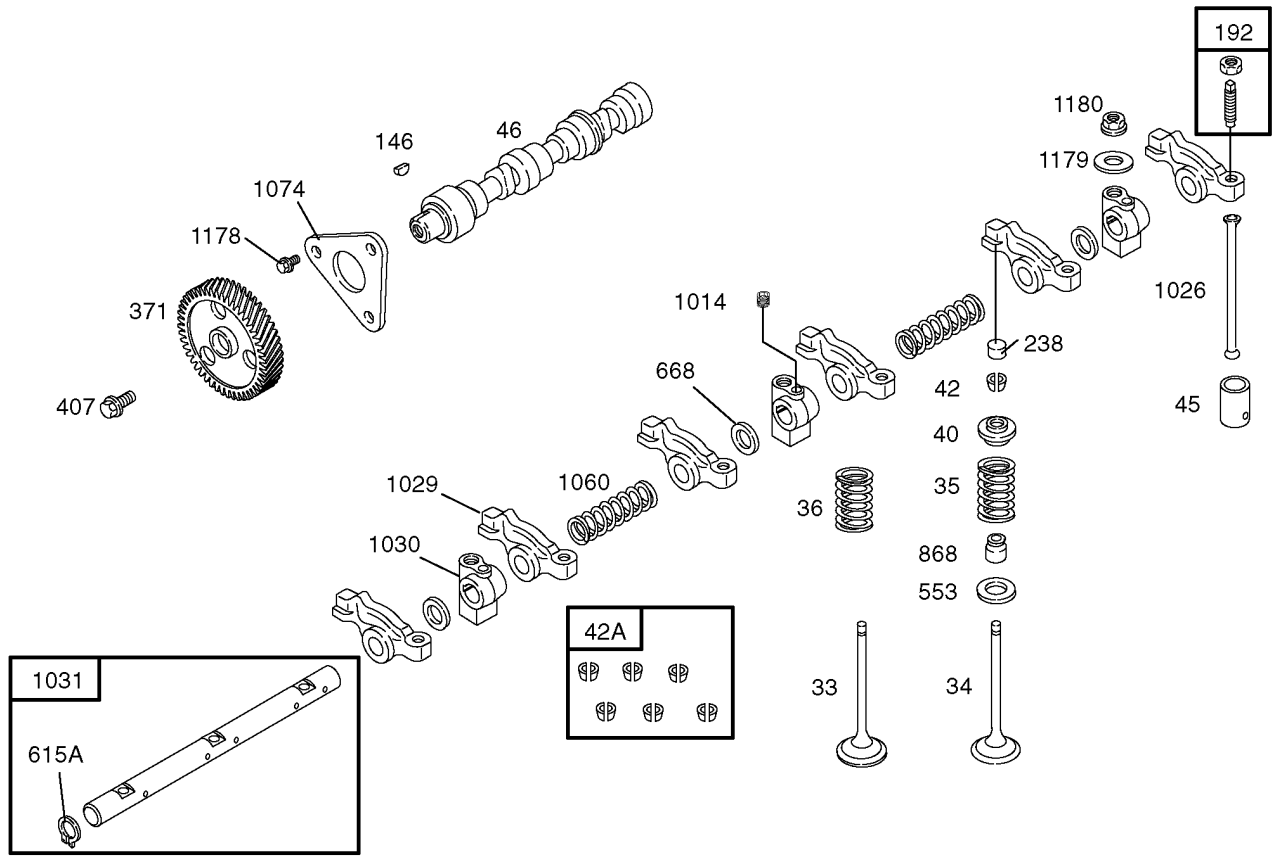

Assemblies include all parts shown in frames.

Cam Shaft Assembly

Ref	Part No.	Qty.	Description
33	99-9080	1	Valve-Exhaust
34	99-9081	1	Valve-Intake
35	99-9082	1	Spring-Valve
36	99-9082	1	Spring-Valve
40	99-9084	1	Retainer-Valve
42	99-9086	1	Keeper-Valve
45	99-9088	1	Tappet-Valve
46	99-9097	1	Shaft-Cam
146	99-9095	1	Key-Woodruff
192	99-9092	1	Adjuster-Arm, Rocker (Use Before Engine Serial #04090100)
192	112-2978	1	Adjuster-Arm, Rocker (Use Before Engine Serial #04083100)
238	99-9094	1	Cap-Valve (Use Before Engine Serial #04090100)
238	112-2979	1	Cap-Valve (Use Before Engine Serial #04083100)
371	99-9641	1	Gear-Cam
407	99-9085	1	Screw-Metric
42A	99-9087	1	Keeper-Valve (Set Of 6)
553	99-9096	1	Seat-Spring, Valve
668	99-9093	1	Washer-Spacer
868	99-9102	1	Seal-Valve
1014	99-9090	1	Screw-Metric

Ref	Part No.	Qty.	Description
1026	99-9103	1	Rod-Push (Use Before Engine Serial #04090100)
1026	112-2980	1	Rod-Push (Use Before Engine Serial #04083100)
1029	99-9104	1	Arm-Rocker
1030	99-9107	1	Support-Arm, Rocker
1031	99-9106	1	Shaft-Arm, Rocker
1060	99-9108	1	Spring-Shaft, Rocker
1074	99-9109	1	Retainer-Camshaft
1178	99-9083	1	Screw-Hex
1179	99-9079	1	Washer-Flat
1180	99-9091	1	Nut-Hex, Metric
615A	99-9099	1	Retainer

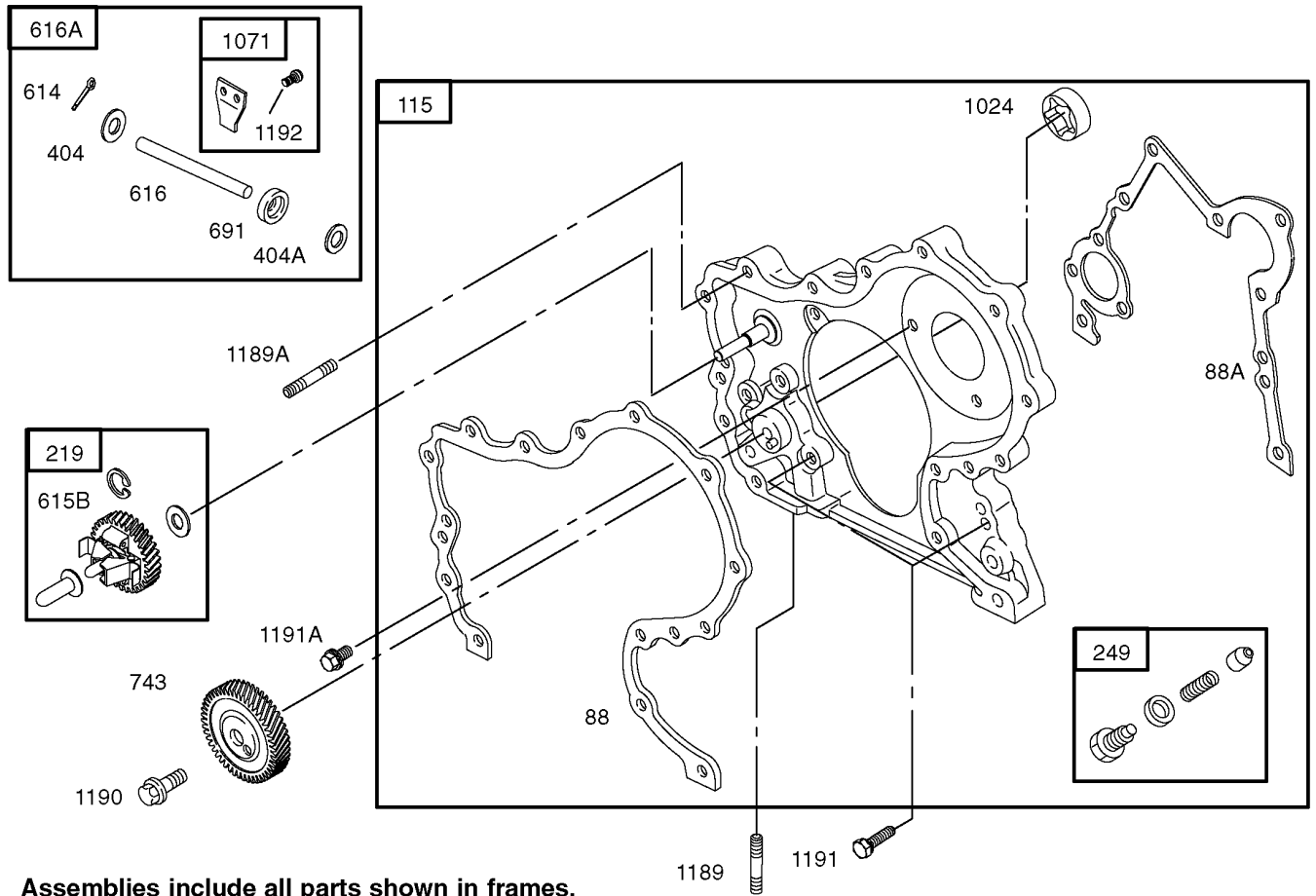

Assemblies include all parts shown in frames.

Gear Housing Assembly

Ref	Part No.	Qty.	Description
1024		1	Pump-Oil
1071	99-9149	1	Paddle-Governor
115	99-9138	1	Housing-Gear
1189	99-9007	1	Stud-Metric
1189A	99-9137	1	Stud-Metric
1190	99-9135	1	Screw-Hex
1191	99-9133	1	Screw-Hex
1191A	99-9134	1	Screw-Hex
1192	99-9143	1	Screw-Hex, Torx
219	99-9261	1	Gear-Governor
249	99-9142	1	Valve-Relief, Oil
404	99-9140	1	Washer-Spacer
404A	99-9141	1	Washer-Spacer
614	99-9053	1	Pin-Cotter
615B	99-9145	1	Retainer
616	99-9146	1	Crank-Governor
616A	99-9147	1	Crank-Governor
691	99-9131	1	Seal-Shaft, Governor
743	99-9656	1	Gear-Drive
88	99-9132	1	Gasket-Cover
88A	99-9136	1	Gasket-Cover, Gear

--	--	--	--	--	--	--	--

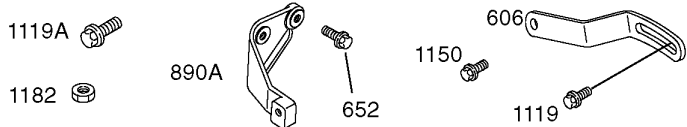
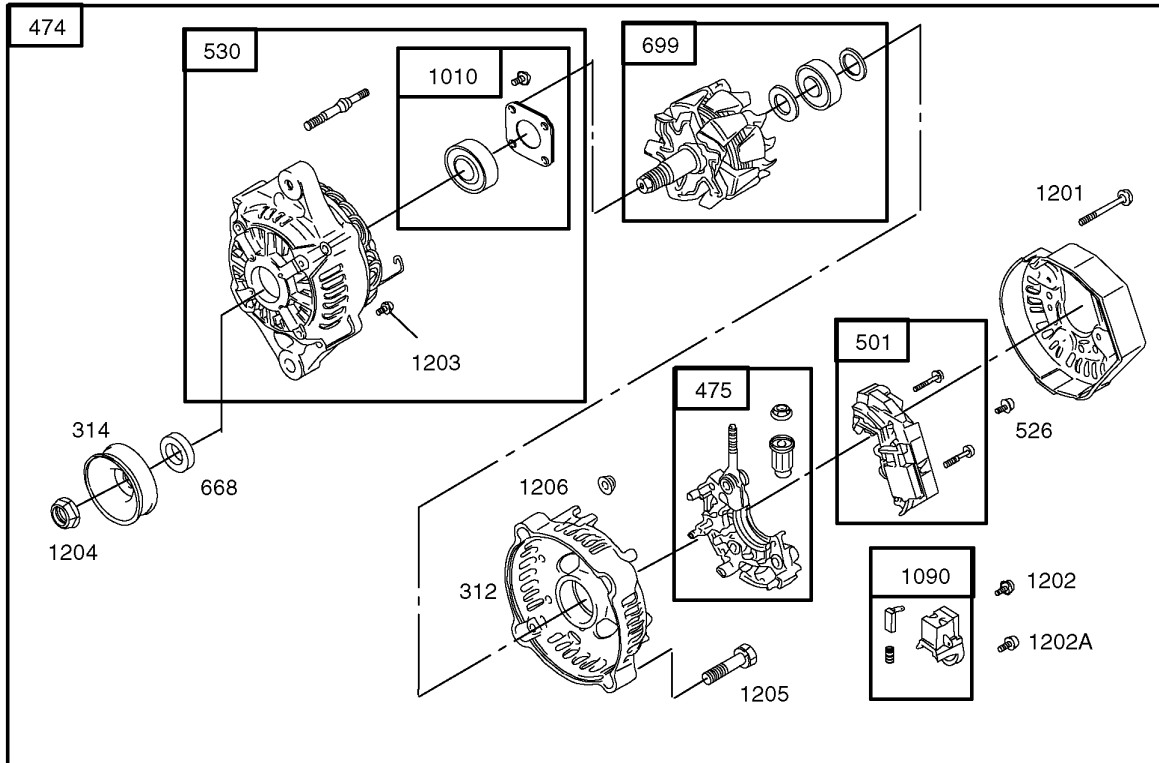

Assemblies include all parts shown in frames.

Alternator Assembly

Ref	Part No.	Qty.	Description
1010	106-1898	1	Retainer-Bearing
1090	106-1899	1	Retainer-Brush
1119	99-9663	1	Screw-Hex, Metric
1119A	99-9205	1	Screw-Hex, Metric
1150	99-9202	1	Screw-Hex
1182	99-9114	1	Nut-Hex, Metric
1201	106-1950	1	Screw
1202	106-1951	1	Screw
1202A	106-1894	1	Screw
1203	106-1894	1	Screw
1204	106-1954	1	Nut
1205	106-1955	1	Screw
1206	106-1956	1	Nut
312	106-1890	1	Housing-End, Brush
314	106-1891	1	Pulley-Alternator
474	99-9209	1	Alternator
475	106-1892	1	Rectifier
501	106-1893	1	Regulator
526	106-1894	1	Screw
530	106-1895	1	Housing-End, Drive
606	106-1952	1	Strap-Adjusting
652	99-9202	1	Screw-Hex
668	106-1896	1	Spacer
699	106-1897	1	Rotor

Ref	Part No.	Qty.	Description
890A	99-9211	1	Bracket-Support

NOTES

NOTES

NOTES

