

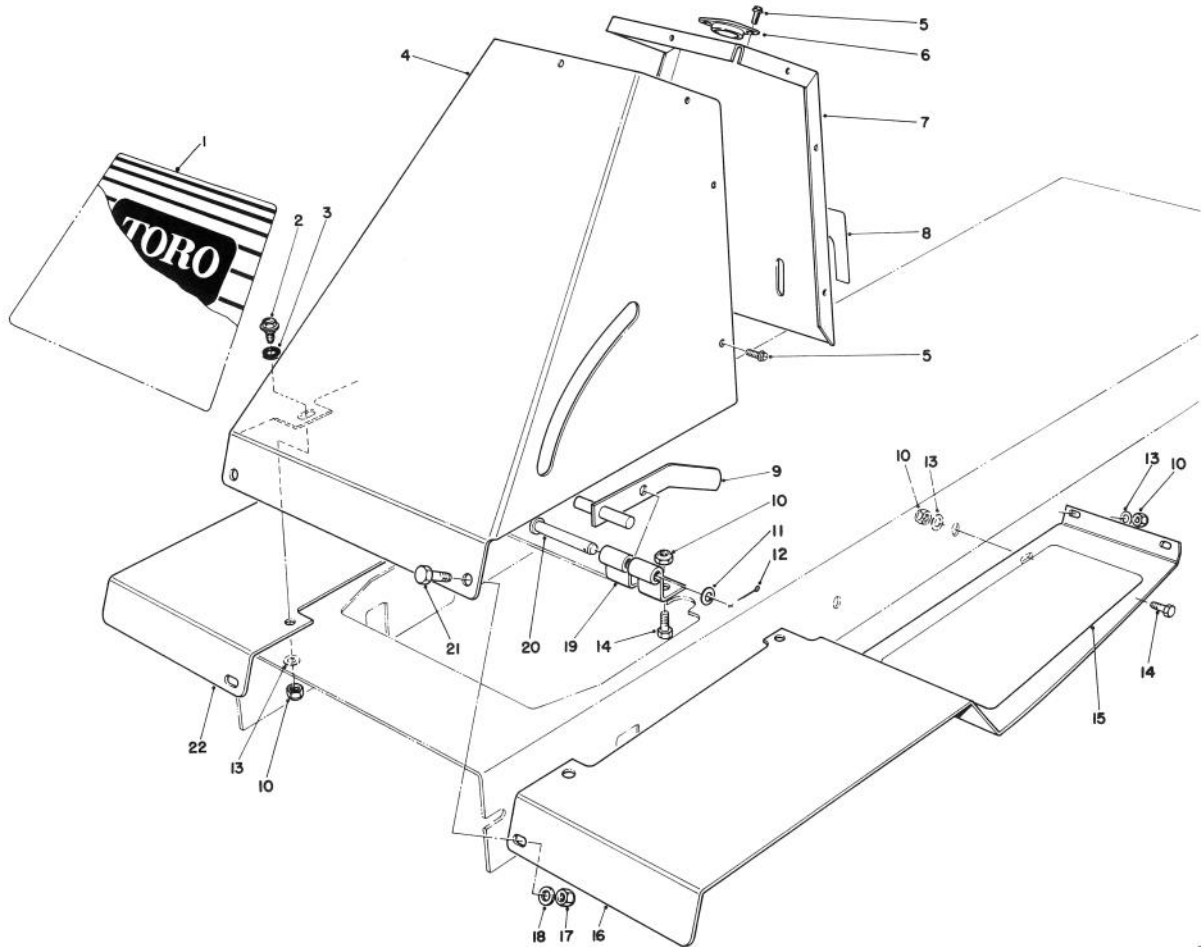

MODEL NO. 56145-9000001 & UP

**PARTS
CATALOG**
8 H.P. REAR ENGINE RIDER — ELECTRIC

C-0434-89

FRONT TOWER ASSEMBLY

Ref. No.	Part No.	Description	No. Used
1	66-6700	Decal — Toro 8-32	1
2	5-2490	Bolt — Shoulder	4
3	3-3287	Spacer — Rubber	4
4	56-7130	Tower — Front	1
5	32104-76	Screw — Self Tapping Acorn Head	9
6	56-7170	Guide — Steering Shaft	1
7	56-7140	Tower — Rear	1
8	56-7810	Decal — Parking Brake	1
9	47-1290	Brake — Parking	1
10	3296-29	Locknut	15
11	3256-24	Washer — Flat	1

Ref. No.	Part No.	Description	No. Used
12	3272-6	Cotter Pin	1
13	3256-23	Washer — Flat	12
14	322-3	Hex Hd. Capscrew	6
15	47-1440	Tread — Foot	2
16	47-0940	Footrest — L.H.	1
17	32152-4	Locknut	2
18	3256-22	Washer — Flat	2
19	47-2060	Bracket — Parking Brake	1
20	283-52	Pin — Clevis	1
21	321-3	Hex Hd. Capscrew	2
22	47-0930	Footrest — R.H.	1
*	12-8809	Loose Parts	1

* Not Illustrated

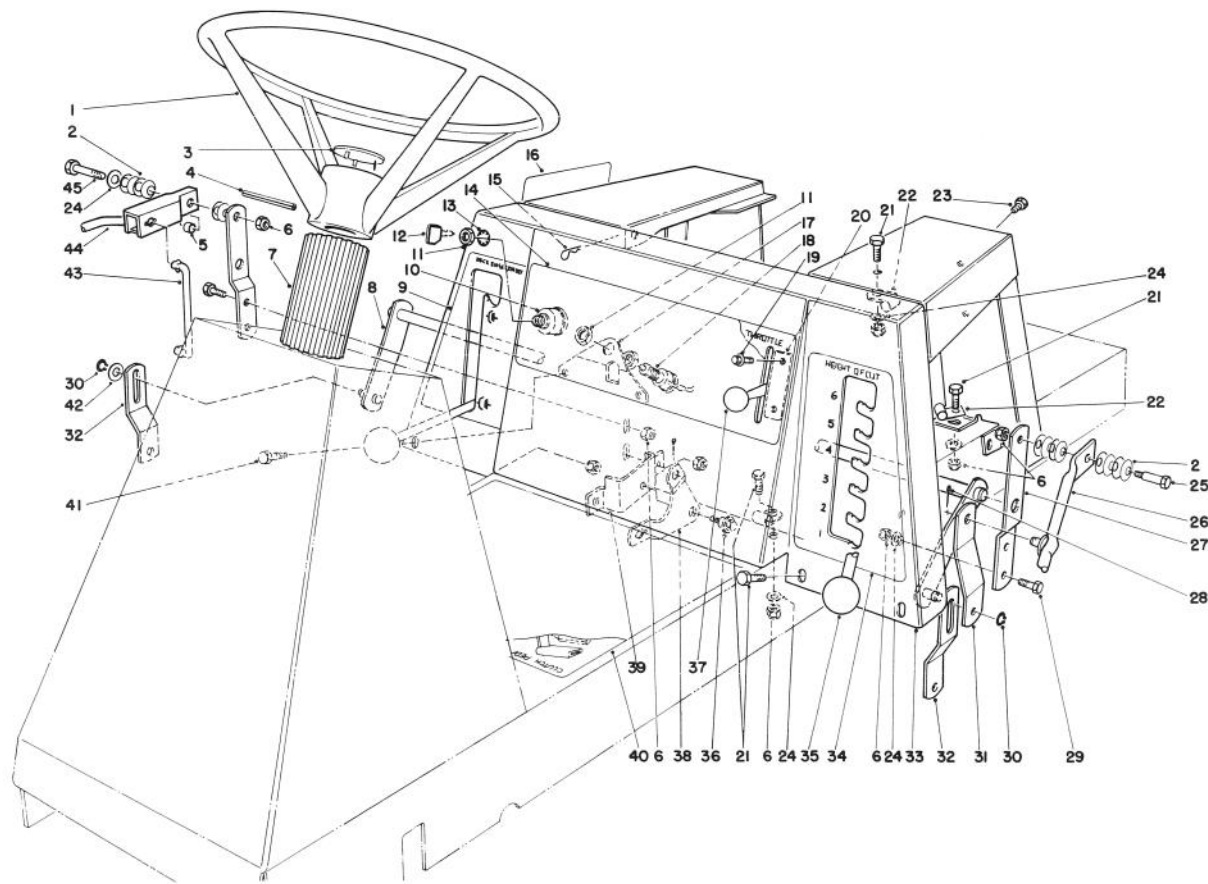

C-0435-89

STEERING WHEEL & LINKAGE ASSEMBLY

Ref. No.	Part No.	Description	No. Used
1	49-3240	Steering Wheel Assembly (Incl. Ref. #3)	1
2	3290-413	Washer — Belleville	14
3	66-6910	Insert — Steering Wheel	1
4	32121-78	Pin — Roll	1
5	61-4300	Spacer — Pivot	1
6	3296-29	Nut — Lock	10
7	66-6740	Cover — Steering Shaft	1
8	56-7400	Arm — Lever, Height of Cut	1
9	56-7840	Decal — Deck Engage	1
10	63-5630	Switch — Ignition (Incl. Ref. #11-13)	1
11	218-461	Nut — Lock	3
12	63-8360	Key	1
13	3254-5	Washer — Lock, Int. Tooth	1
14	56-7820	Decal — Ignition & Throttle	1
15	3290-307	Hairpin — Cotter	2
16	66-6780	Decal — Shift Pattern	1
17	56-7150	Bracket — Mounting, Switch	1
18	56-7640	Switch — Deck (Incl. Ref. #11)	1
19	32104-76	Screw — Self Tapping, Acorn Head	2
20	56-7220	Control — Throttle (Incl. Ref. #37)	1
21	322-4	Screw — Cap, Hex Hd.	5
22	2412-68	Clamp	3

Ref. No.	Part No.	Description	No. Used
23	321-3	Screw — Cap, Hex Hd.	2
24	3256-23	Washer — Flat	8
25	28-0540	Bolt — Shoulder	1
26	47-1850	Lever — Height of Cut	1
27	47-1840	Bracket — Height of Cut	1
28	3272-6	Pin — Cotter	2
29	322-5	Screw — Cap, Hex Hd.	5
30	32151-61	Ring — Retaining	2
31	56-7360	Bracket — Height of Cut Engagement	1
32	63-5830	Link — Deck Suspension	2
33	56-7300	Body — Seat	1
34	56-7830	Decal — Height of Cut	1
35	233-48	Knob	2
36	19-1470	Bolt — Shoulder	1
37	233-59	Knob	1
38	56-7540	Bell Crank — Deck Engage	1
39	56-7550	Bracket — Bell Crank Mounting	1
40	56-7800	Decal — Instructions	1
41	322-3	Screw — Cap, Hex Hd.	2
42	3256-26	Washer — Flat	1
43	56-7560	Link — Bell Crank	1
44	61-4250	Lift Arm Assembly	1
45	322-9	Screw — Cap, Hex Hd.	1

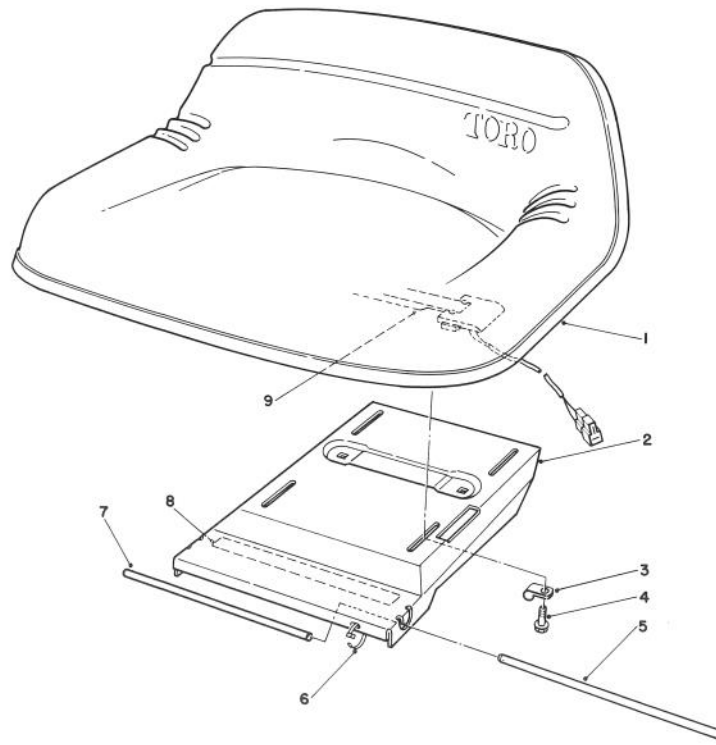

C-0436-89

SEAT ASSEMBLY

Ref. No.	Part No.	Description	No. Used
1	55-8691	Seat Assembly (Incl. Ref. #9)	1
2	63-5540	Base — Seat	1
3	2412-68	Clamp — Wire	1
4	3234-5	Screw — Hex Hd. Cap	4
5	56-7210	Rod — Seat Base	1

Ref. No.	Part No.	Description	No. Used
6	3290-378	Tie — Cable	1
7	63-5670	Tube — Seat Rod Bumper	1
8	63-5890	Decal	1
9	38-1420	Switch — Interlock, Seat	1

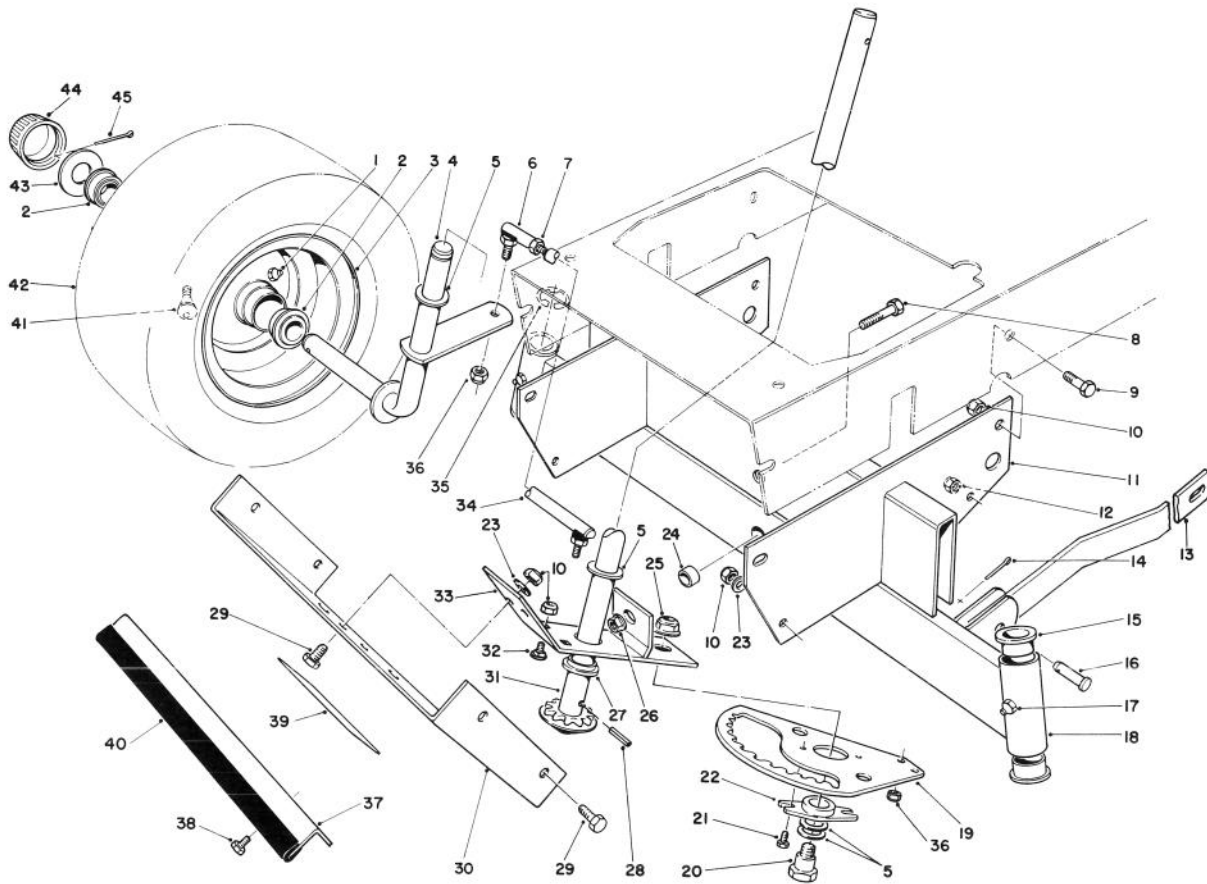

C-0438-89

FRONT AXLE ASSEMBLY

Ref. No.	Part No.	Description	No. Used
1	302-5	Fitting — Grease	2
2	251-210	Bearing	4
3	217-80	Rim	2
4	47-0600	Spindle — R.H.	1
*	47-0590	Spindle — L.H.	1
5	3-6498	Washer — Thrust	5
6	2411-32	Ball Joint	2
7	3220-2	Nut — Hex Jam	2
8	325-6	Capscrew — Hex Hd.	1
9	322-2	Capscrew — Hex Hd.	2
10	3296-29	Nut — Lock	8
11	47-0760	Support — Front Axle	1
12	32152-4	Nut — Lock	1
13	47-0010	Arm — Front Deck Suspension	2
14	3272-6	Pin — Cotter	2
15	27-9080	Bearing — Flange	4
16	283-2	Pin — Clevis	2
17	302-49	Fitting — Grease	2
18	47-0980	Axle — Front (Incl. Ref. #15 & 17)	1
19	56-7510	Rack — Steering	1
20	56-7530	Bolt — Shoulder	1
21	12-3270	Screw — Special	2
22	56-7520	Bushing — Sector	1
23	3256-23	Washer — Flat	6

Ref. No.	Part No.	Description	No. Used
24	28-0380	Spacer — Front Axle	1
25	32128-21	Nut — Flange Lock	1
26	32128-23	Nut — Lock	1
27	47-0700	Bearing — Flange	1
28	32121-9	Pin — Roll	1
29	322-4	Capscrew — Hex Hd.	6
30	56-7180	Cover — Front	1
31	56-7500	Shaft — Steering	1
32	3230-18	Bolt — Carriage	2
33	56-7470	Bracket — Steering Rack (Incl. Ref. #27)	1
34	47-0610	Tie Rod — Steering (Incl. Ref. #35 & 36)	2
35	32151-48	Ring — Retaining External	2
36	3296-4	Nut — Lock	4
37	57-6010	Guard — Front	1
38	32144-11	Screw — Thread Forming	2
39	26-4830	Decal — Instructions	1
40	57-6040	Trim — Front Guard	1
41	232-27	Valve Stem w/Cap	2
42	231-116	Tire	2
43	28-2480	Washer	2
44	61-9780	Hub Cap	2
45	3272-12	Pin — Cotter	2
†	232-44	Inner Tube	2

* Not Illustrated

† Service Replacement Part

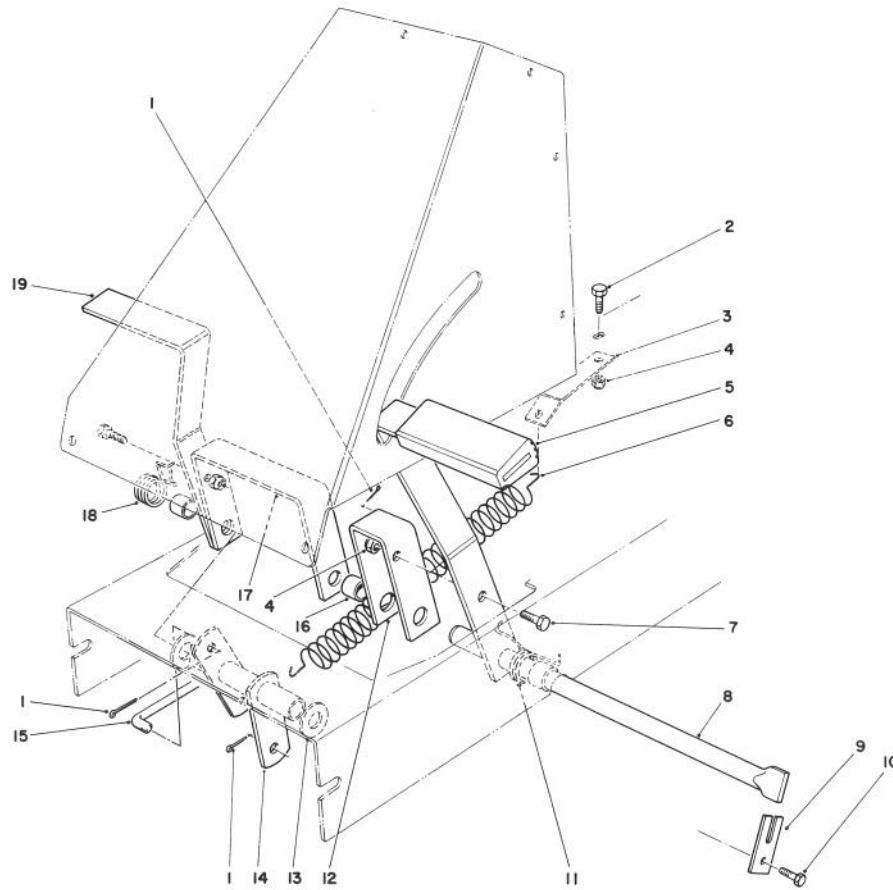

C-0439-89

BRAKE & CLUTCH ASSEMBLY

Ref. No.	Part No.	Description	No. Used
1	3272-6	Pin — Cotter	3
2	322-3	Screw — Cap, Hex Hd.	1
3	56-7240	Bracket — Spring Retaining	1
4	3296-29	Nut — Lock	3
5	65-2920	Pad — Foot Pedal	2
6	62-3930	Spring — Extension	1
7	322-5	Screw — Cap, Hex Hd.	2
8	47-0770	Shaft — Pedal Pivot	1
9	47-0780	Retainer — Shaft	1
10	321-3	Screw — Cap, Hex Hd.	1

Ref. No.	Part No.	Description	No. Used
11	56-7070	Spring — Torsion Clutch	1
12	47-0560	Bracket — Clutch Pedal	1
13	3256-27	Washer — Flat	3
14	56-7650	Tube — Pivot	1
15	56-7570	Rod — Engagement	1
16	47-0570	Spacer — Pedal	3
17	47-0550	Bracket — Pedal, Brake	1
18	56-7080	Spring — Brake, Torsion	1
19	47-0540	Pedal	2

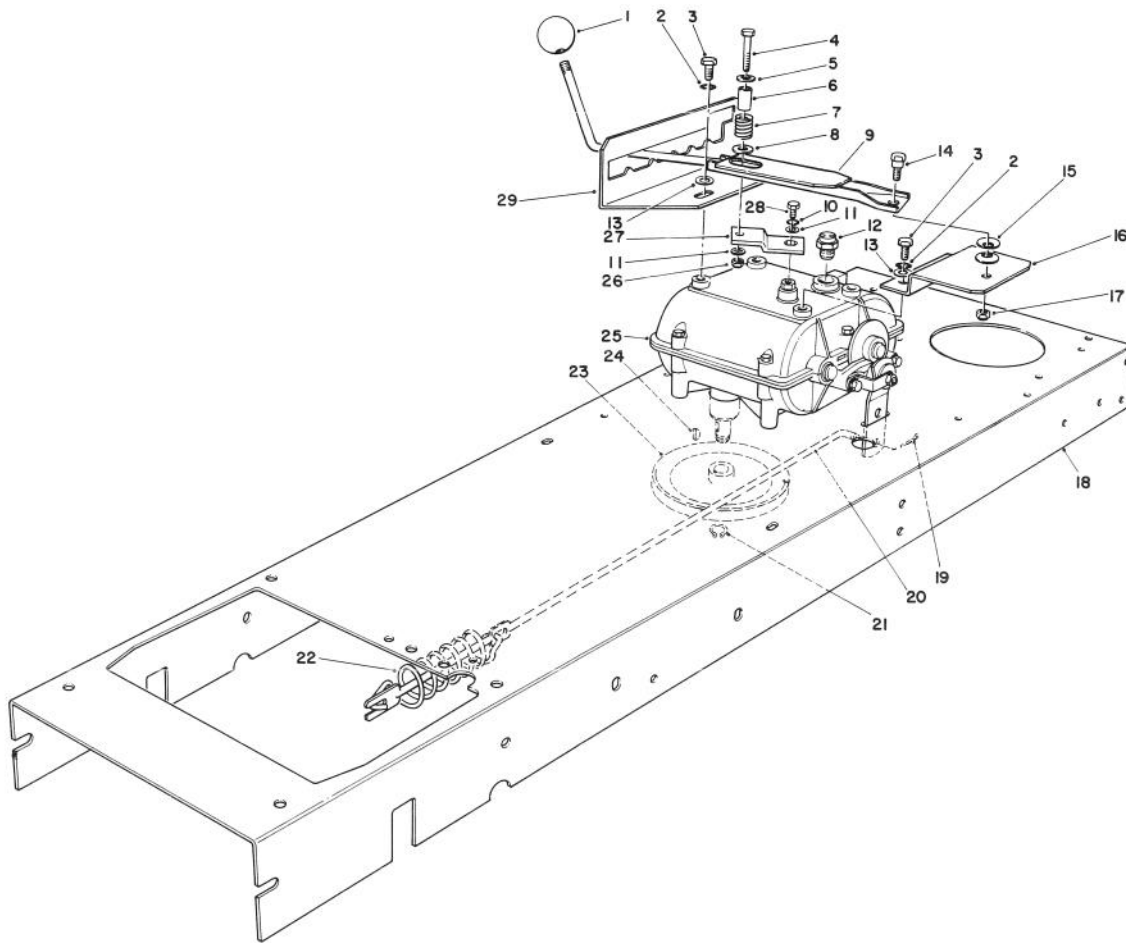

C-0430-89

TRANSMISSION LINKAGE ASSEMBLY

Ref. No.	Part No.	Description	No. Used
1	233-48	Knob	1
2	3253-4	Washer — Lock	4
3	32144-11	Screw — Thread Forming	4
4	321-15	Capscrew — Hex Hd.	1
5	3256-55	Washer — Fender	1
6	56-7740	Spacer — Split	1
7	56-7730	Spring — Compression	1
8	3256-4	Washer — Flat	1
9	56-7600	Lever — Shift	1
10	3253-3	Washer — Lock	2
11	3256-22	Washer — Flat	2
12	28-4250	Switch — Neutral Start	1
13	3256-23	Washer — Flat	4
14	19-1470	Bolt — Shoulder	1
15	3290-413	Washer — Belleville	2

Ref. No.	Part No.	Description	No. Used
16	56-7610	Bracket — Shift Mounting	1
17	3296-29	Nut — Lock	1
18	56-7160	Frame — Main	1
19	3272-16	Pin — Cotter	1
20	56-7060	Rod — Brake	1
21	32120-64	Ring — Retaining External	1
22	57-9940	Spring — Brake	1
23	7-4085	Pulley — Transmission	1
24	3257-5	Key — Woodruff	1
25	47-1530	Transmission — 5 Speed	1
26	32152-4	Nut — Lock	1
27	56-7620	Lever — Shift	1
28	329-4	Capscrew — Hex Hd.	1
29	56-7630	Gate — Shift	1

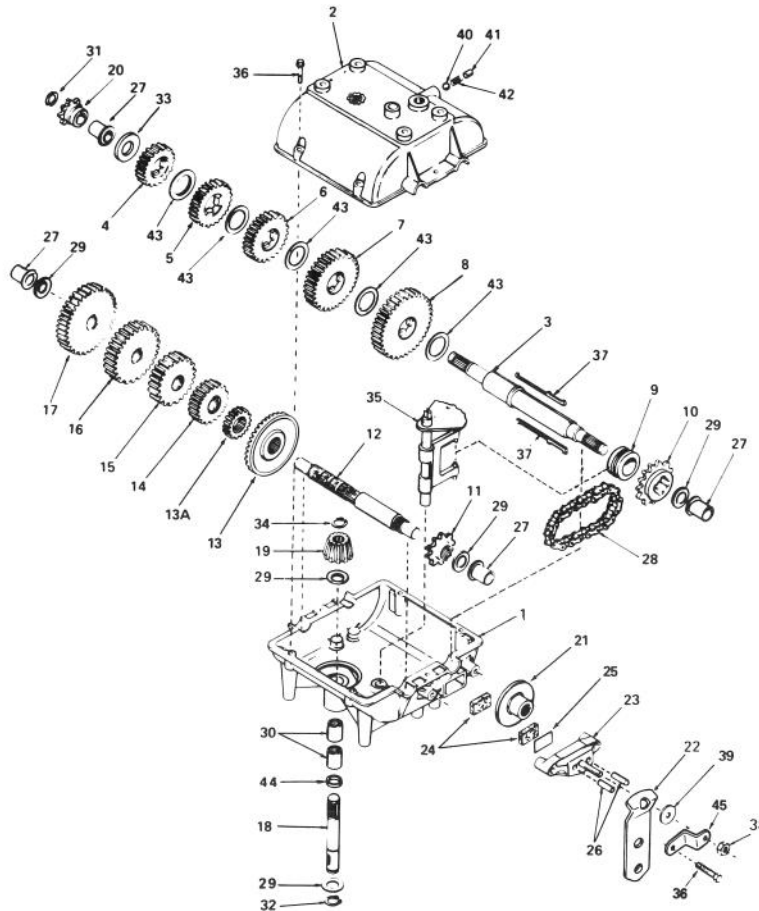

C-0431-89

TRANSMISSION MODEL 770A

Ref. No.	Part No.	Description	No. Used
1	770061	Case — Transmission	1
2	772083	Cover — Transmission	1
3	776161	Shaft — Output & Brake	1
4	778121A	Gear — Spur (20 teeth)	1
5	778122A	Gear — Spur (22 teeth)	1
6	778123A	Gear — Spur (25 teeth)	1
7	778124A	Gear — Spur (30 teeth)	1
8	778125	Gear — Spur (35 teeth)	1
9	784266	Collar — Shift	1
10	786083	Sprocket (18 teeth)	1
11	786082	Sprocket (9 teeth)	1
12	776134	Shaft — Counter	1
13	778137A	Gear — Bevel (42 teeth)	1
13A	778136	Gear — Spur (15 teeth)	1
14	778126A	Gear — Spur (20 teeth)	1
15	778127A	Gear — Spur (25 teeth)	1
16	778128A	Gear — Spur (28 teeth)	1
17	778129A	Gear — Spur (30 teeth)	1
18	776135	Shaft — Input	1
19	778113A	Bevel Pinion — Input	1
20	786048	Sprocket (8 teeth)	1
21	790003	Disk — Brake	1
22	790013	Lever — Brake	1
23	790025	Holder — Brake Pad	1

Ref. No.	Part No.	Description	No. Used
24	790006	Pad — Brake	1
25	790007	Plate — Brake Pad	1
26	786026	Pin — Dowel	1
27	780105A	Bushing — Flanged	1
28	786081	Chain Roller (No. 41 chain, 24 links)	1
29	780072	Race — Thrust	1
30	780086	Bearing — Needle	1
31	792072	Ring — Retaining	1
32	792035	Ring — Retaining	1
33	780109	Washer	1
34	788040	Ring — Retaining	1
35	784267	Rod & Fork Assy. — Shift	1
36	792073	Screw — Hex Hd.	1
37	792089A	Key	1
38	792075	Nut — Lock	1
39	792076	Washer — Flat	1
40	792077	Ball — Steel	1
41	792078	Screw — Set	1
42	792079	Spring	1
43	780108	Washer — Thrust	1
44	792001	Ring — Square Cut	1
45	786086	Bracket — Brake Lever	1

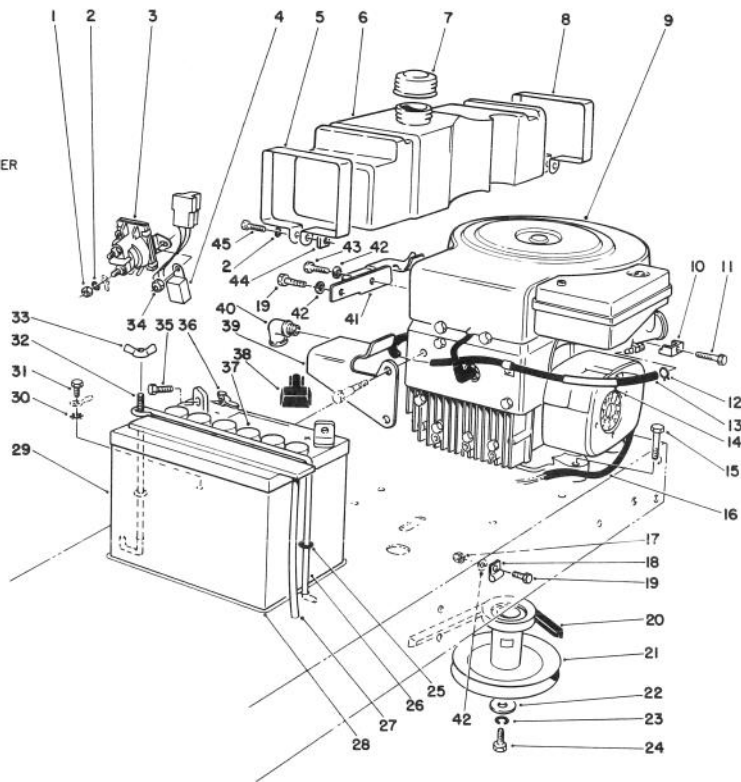
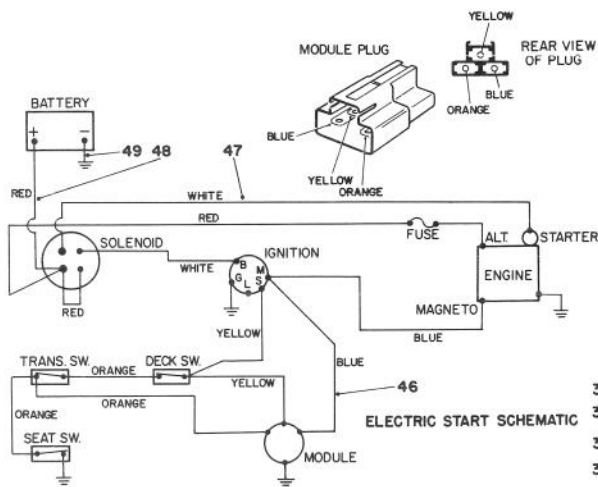

C-0433-89

ENGINE ASSEMBLY

Ref. No.	Part No.	Description	No. Used
1	3218-1	Hex Jam Nut	2
2	3253-3	Lockwasher	4
3	47-1910	Solenoid	1
4	28-7890	Module — Interlock	1
5	57-4060	Retainer — Tank Front	1
6	56-7050	Tank — Gas	1
7	55-3570	Gas Cap Assembly	1
8	57-4070	Retainer — Tank Rear	1
9		Engine	1
10	2210-249	Clamp — Casing	1
11	2210-248	Hex Hd. Capscrew	1
12	2412-98	Clamp — Gas	2
13	47-2986	Hose — Fuel Line	1
14	62-5490	Support — Fuel Line	1
15	322-7	Hex Hd. Capscrew	3
16	57-4150	Cover — Protective	1
17	3296-29	Locknut	1
18	2412-68	Clamp	1
19	322-4	Screw — Hex Hd.	2
20	47-1410	Belt — Traction Drive	1
21	47-1960	Pulley — Engine	1
22	3256-25	Washer — Flat	1
23	3253-22	Lockwasher	1
24	62-3760	Hex Hd. Capscrew	1
25	237-143	“O”-Ring	2

Ref. No.	Part No.	Description	No. Used
26	56-7710	Hold Down — Battery	1
27	56-2540	Tube — Battery Vent	1
28	62-4300	Pad — Anti Skid	1
29	56-7700	Battery — 12V	1
30	3254-2	Lockwasher — External Tooth	1
31	32104-82	Screw — Self Tapping	1
32	56-7720	Post — Battery	1
33	32103-12	Nut — Wing	1
34	32152-4	Locknut	2
35	321-3	Hex Hd. Capscrew	2
36	32103-22	Nut — Wing	2
37	218-560	Cap — Battery	6
38	28-8080	Boot — Terminal	1
39	57-4040	Bracket — Mount Tank Front	1
40	2811-10	Elbow — 90° Street	1
41	57-4050	Bracket — Mount Tank Rear	1
42	3256-23	Washer — Flat	3
43	322-2	Screw — Hex Hd.	1
44	32107-11	Nut — Square	2
45	3274-51	Hex Socket Hd. Capscrew	2
46	56-7680	Wire Harness	1
47	56-7660	Wire Harness — Starter	1
48	56-7670	Cable — Battery Positive	1
49	56-7870	Wire Assembly — Ground	1

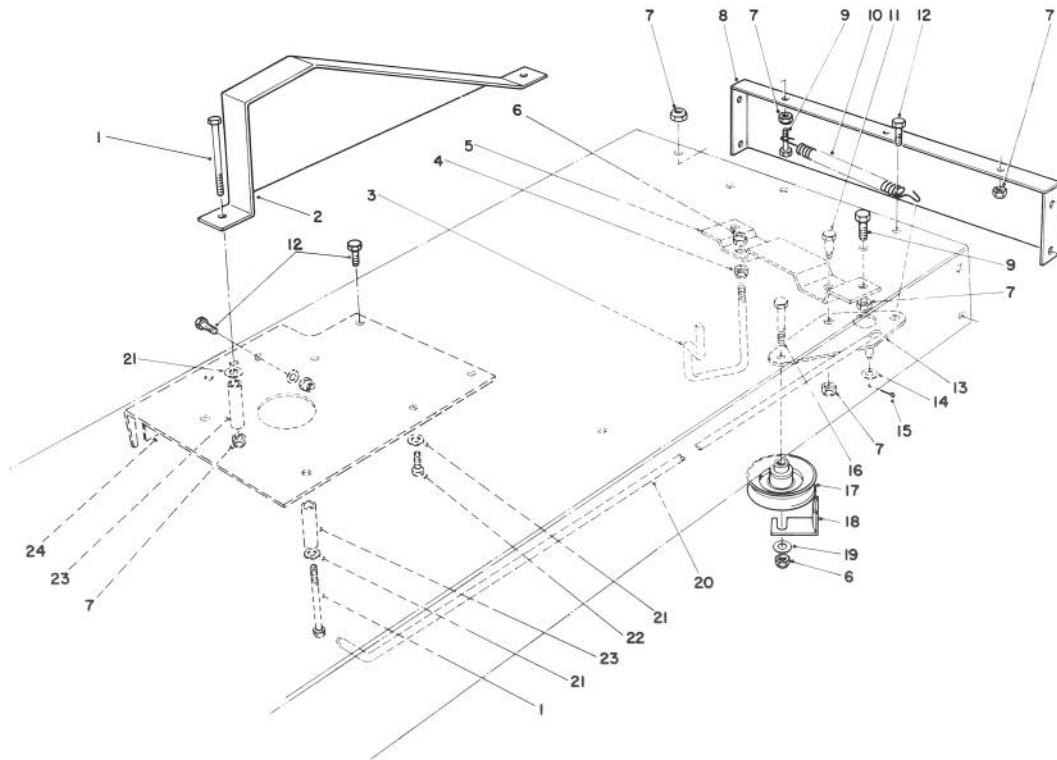

C-0434-89

TRACTION ASSEMBLY

Ref. No.	Part No.	Description	No. Used
1	322-11	Hex Hd. Capscrew	2
2	47-1220	Guard — Chain	1
3	47-0500	Guide — Belt	1
4	32153-2	Locknut	1
5	47-0471	Bracket — Traction Support	1
6	32152-2	Locknut	2
7	3296-29	Locknut	8
8	47-0730	Frame — Rear	1
9	322-7	Hex Hd. Capscrew	2
10	27-8960	Spring — Extension	1
11	37-8770	Bolt — Shoulder	1
12	322-3	Hex Hd. Capscrew	4

Ref. No.	Part No.	Description	No. Used
13	47-0481	Bracket — Traction Pivot	1
14	3256-22	Washer — Flat	1
15	3272-6	Pin — Cotter	1
16	323-9	Hex Hd. Capscrew	1
17	12-5820	Pulley — Idler	1
18	12-9020	Retainer Belt	1
19	3256-24	Washer — Flat	1
20	47-0490	Rod — Traction	1
21	3256-23	Washer — Flat	7
22	32140-45	Screw — Machine Hex Hd.	3
23	47-0920	Spacer — Split	2
24	47-1950	Plate — Reinforcement	1

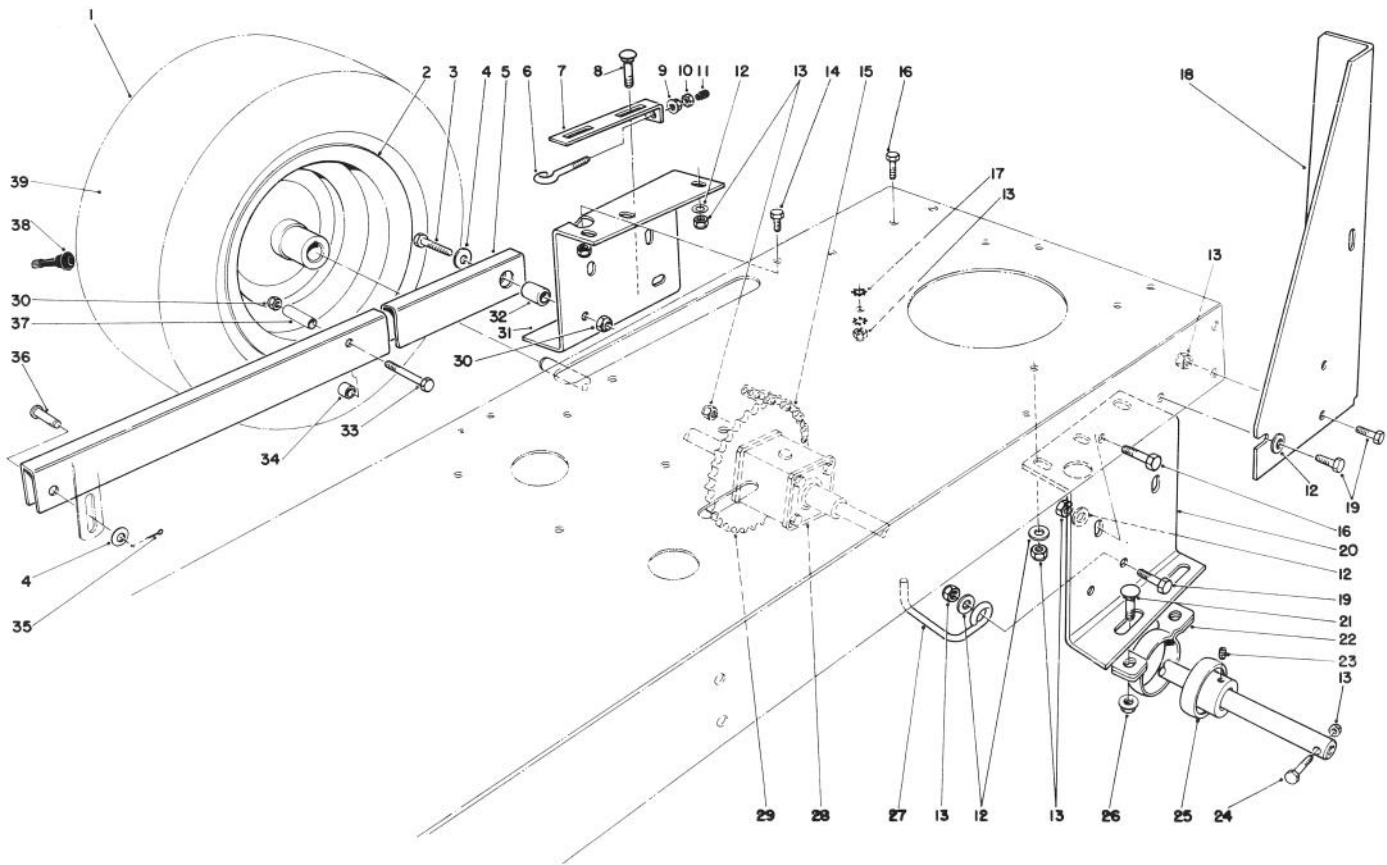

C-0435-89

REAR AXLE ASSEMBLY

Ref. No.	Part No.	Description	No. Used
1	231-117	Tire	2
2	242-78	Rim	2
3	323-9	Hex Hd. Capscrew	2
4	3256-24	Washer — Flat	4
5	47-0020	Arm — Rear Deck Suspension	2
6	61-9980	Screw — Adjusting	1
7	61-9990	Plate — Adjusting	1
8	3231-25	Bolt — Carriage	2
9	32128-33	Nut — Flange	1
10	3217-5	Nut — Hex	1
11	2410-66	Tip — Rod	1
12	3256-23	Washer — Flat	12
13	3296-29	Locknut	18
14	322-3	Hex Hd. Capscrew	1
15	56-7230	Chain — Roller	1
16	322-4	Hex Hd. Capscrew	4
17	3254-2	Lockwasher — External Tooth	2
18	56-7450	Standbar — L.H.	1
*	56-7440	Standbar — R.H.	1
19	322-5	Hex Hd. Capscrew	7
20	56-7420	Support — Axle Rear L.H.	1

Ref. No.	Part No.	Description	No. Used
21	3231-25	Carriage Bolt	2
22	47-1480	Retainer — Pillow Block	2
23	3245-35	Set Screw	4
*	3246-15	Set Screw	4
24	46-2511	Bolt	2
25	47-1490	Bearing — Ball (Incl. Ref. #23)	2
26	32128-21	Flange Locknut	4
27	47-2010	Belt Guide — Engine Pulley	1
28	56-7110	Differential	1
29	56-7090	Sprocket — Differential	1
30	32152-2	Locknut	4
31	63-5820	Support — Axle Rear R.H.	1
32	56-7430	Pin — Arm Support	2
33	323-13	Hex Hd. Capscrew	2
34	47-0910	Spacer — Inner	2
35	3272-6	Pin — Cotter	2
36	283-42	Pin — Clevis	2
37	47-0920	Spacer — Split	2
38	232-27	Valve Stem w/Cap	2
39†	232-39	Inner Tube	2

* Not Illustrated

† Service Replacement Part

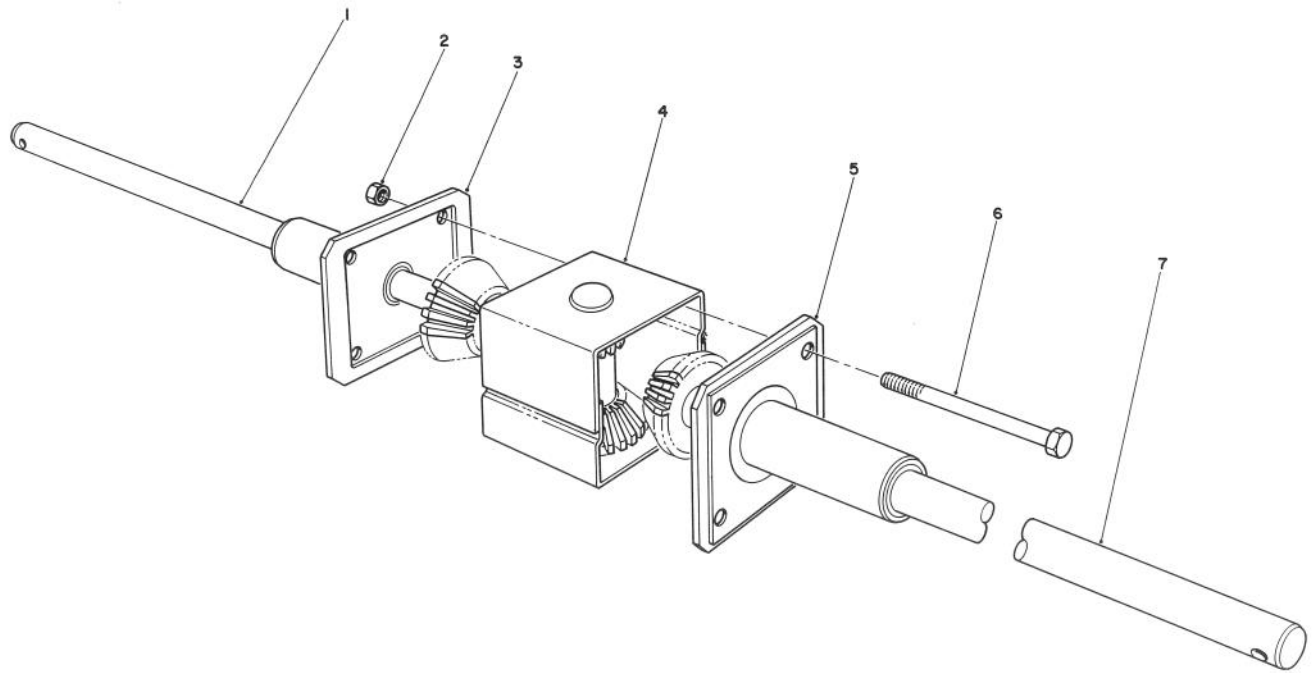

C-0010-89

DIFFERENTIAL ASSEMBLY

Ref. No.	Part No.	Description	No. Used
1	55-7760	Axle — R.H.	1
2	32152-1	Locknut	4
3	55-7770	End Cap — R.H.	1
4	55-7780	Gear Case — Transfer	1

Ref. No.	Part No.	Description	No. Used
5	55-7771	End Cap — L.H.	1
6	322-22	Hex Hd. Capscrew	4
7	55-7761	Axle — L.H.	1
*	56-7110	Differential Complete	1

* Not Illustrated

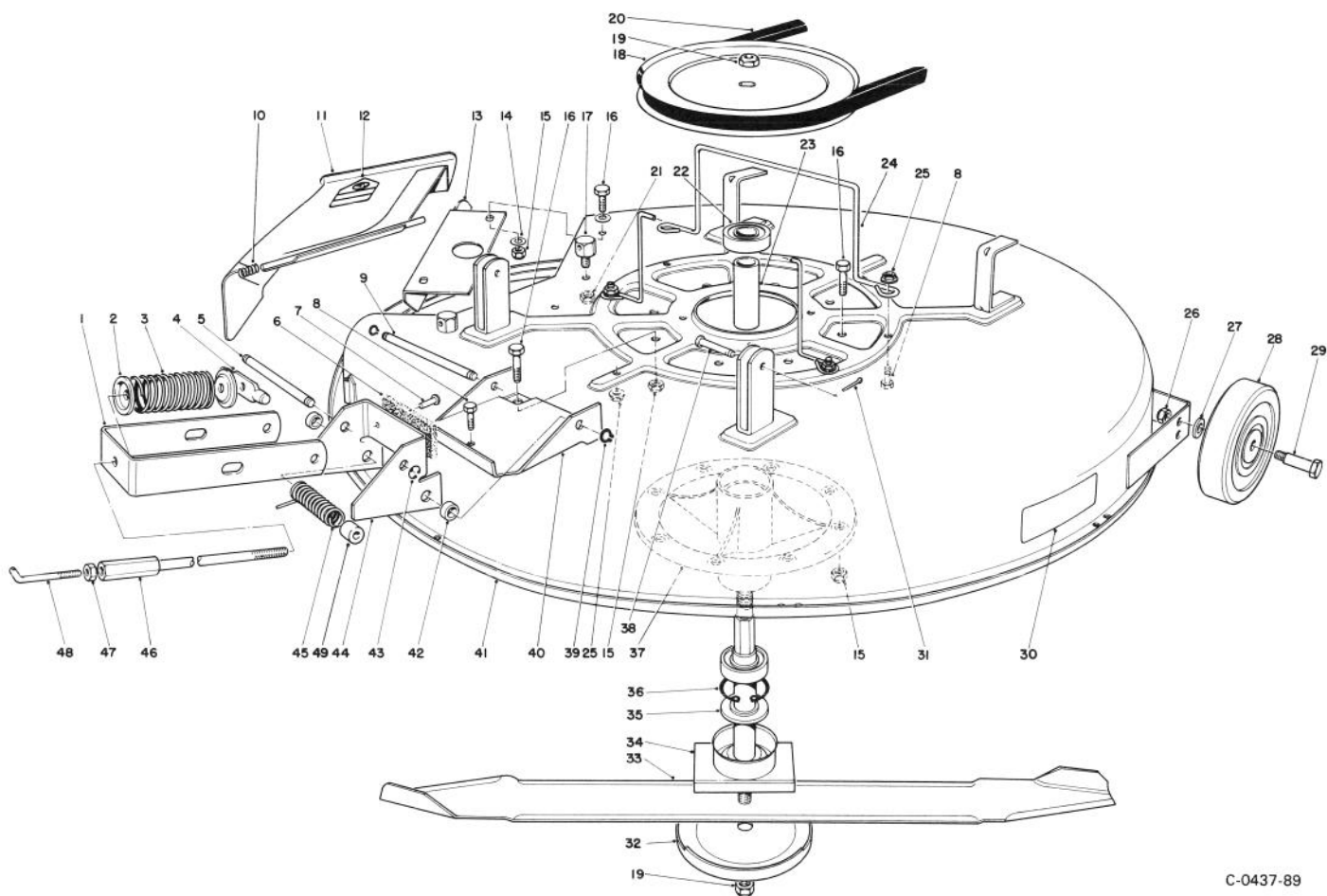

C-0437-89

MOWER ASSEMBLY

Ref. No.	Part No.	Description	No. Used
1	47-1180	Bracket — Engagement	1
2	47-1140	Retainer — Spring Top	2
3	47-0960	Spring — Compression	1
4	47-1200	Shaft — Adjusting	1
5	47-1230	Pin — Clevis	1
6	47-0210	Pad — Brake	1
7	3295-43	Rivet	2
8	321-4	Capscrew	5
9	47-1670	Pin — Clevis	1
10	28-8010	Spring — Torsion	1
11	44-5930	Deflector Assembly (Incl. Ref. #12)	1
12	54-9220	Decal — Deflector Caution	1
13	44-5720	Baffle Deck	1
14	3256-23	Washer — Plain	4
15	3296-29	Nut — Lock	10
16	322-4	Capscrew	10
17	28-7350	Pivot Post	1
18	47-1350	Pulley	1
19	17-0980	Nut — Special	2
20	47-1420	V-Belt	1
21	32153-2	Nut — Lock	1
22	251-297	Bearing	2
23	47-0100	Spacer — Bearing	1
24	60-9730	Guide — Belt	2
25	32128-10	Nut — Locking Flange	5

Ref. No.	Part No.	Description	No. Used
26	3296-39	Nut — Lock	2
27	3256-24	Washer — Plain	2
28	61-9760	Wheel	2
29	56-6590	Wheel Bolt	2
30	47-7240	Decal — Deck	1
31	3272-6	Cotter Pin	2
32	7-3522	Anti-Scalp Cup	1
33	33-4750	Blade	1
34	47-0090	Spindle Shaft	1
35	47-0110	Spacer — Spindle	1
36	32120-11	Ring — Retaining Internal	1
37	56-7030	Spindle Body	1
38	283-2	Pin Clevis	2
39	32151-57	Ring — Retaining External	2
40	47-1240	Channel — Deck Engagement	1
41	47-1600	Cutter Deck	1
42	47-1900	Spacer — Deck Brake Support	2
43	32120-18	Ring — Retaining External	2
44	47-1610	Support Deck Brake Assembly (Incl. Ref. #6 & 7)	1
45	40-6230	Spring — Torsional	1
46	47-1150	Hub — Adjusting	1
47	3218-3	Nut — Jam	1
48	47-1130	Rod — Adjusting	1
49	26-8940	Spacer	1

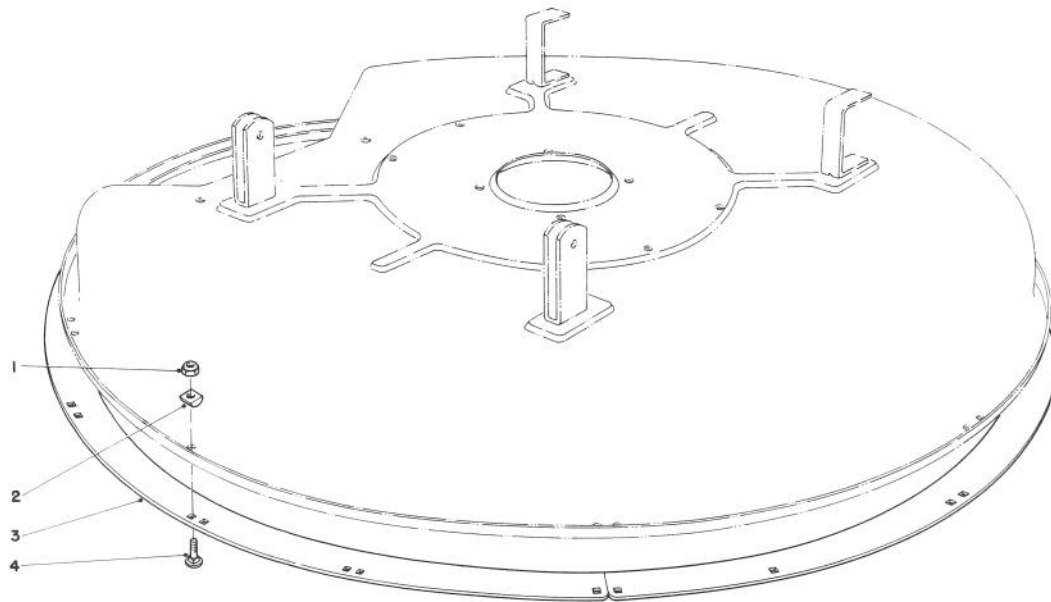

C-0438-89

WET GRASS BAGGING KIT NO. 38-5730 (Optional)

Ref. No.	Part No.	Description	No. Used
1	3296-29	Locknut	12
2	56-7880	Spacer — Deck Ring	12

Ref. No.	Part No.	Description	No. Used
3	38-6030	Ring — Deck	4
4	3230-2	Carriage Bolt	12

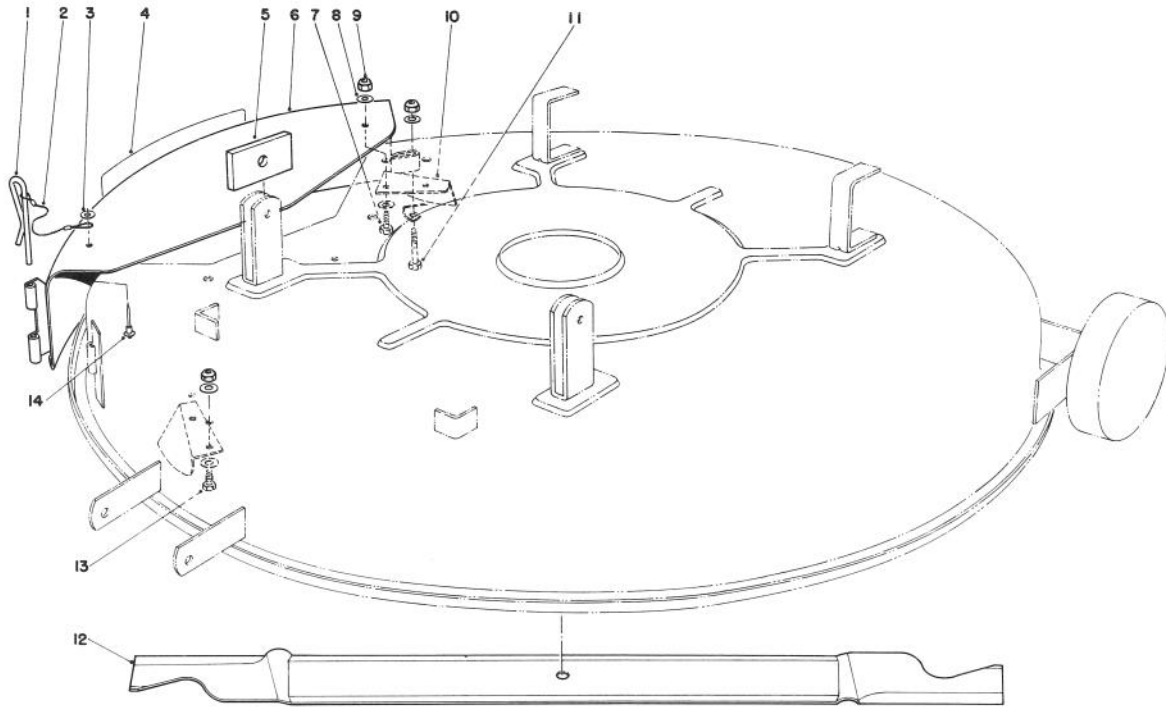

C-0439-89

MULCHER KIT MODEL 59155 (Optional)

Ref. No.	Part No.	Description	No. Used
1	28-8130	Pin — Chute Locking	1
2	28-8070	Lanyard	1
3	3256-49	Washer	1
4	44-5910	Decal — Mulcher Cover	1
5	44-5820	Spacer — Deck Angle	2
6	44-5700	Cover — Mulcher Assembly (Incl. Ref. #1-4 & 14)	1
7	322-5	Capscrew — Hex Head	1

Ref. No.	Part No.	Description	No. Used
8	3256-23	Washer	9
9	3296-29	Locknut	5
10	44-5810	Kicker	2
11	322-10	Capscrew — Hex Head	1
12	39-3480	Blade — Mulcher	1
13	322-3	Capscrew — Hex Head	3
14	3290-282	Rivet — Pop	1

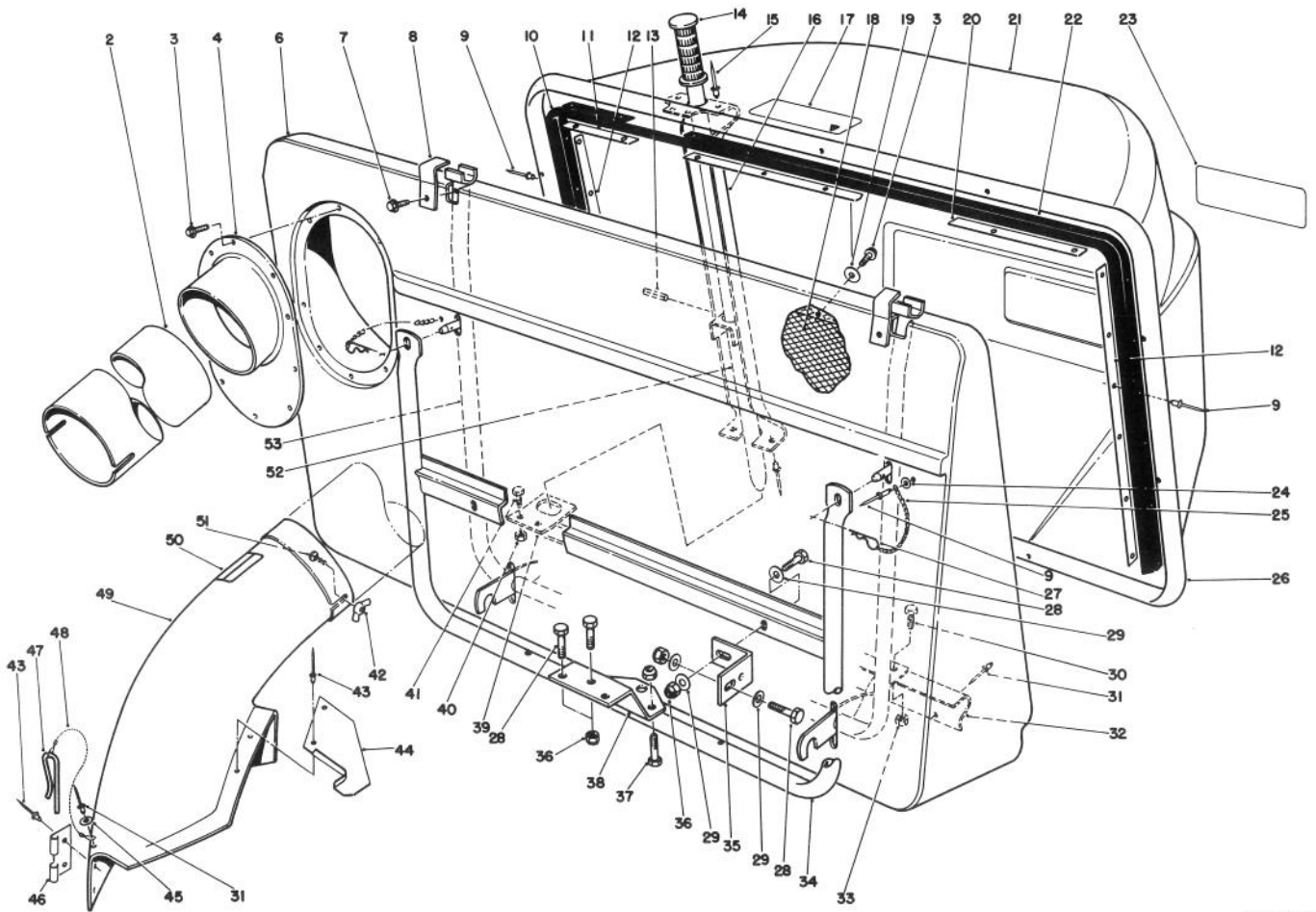

C-0440-89

EASY-EMPTY GRASS CATCHER MODEL 59111 (Optional)

Ref. No.	Part No.	Description	No. Used
2	47-7210	Duct	1
3	32104-76	Screw — Self Tapping	18
4	62-4240	Adaptor — Duct	1
6	28-7810	Bag — Front	1
7	32104-60	Screw — Hex Hd. Self Tapping	2
8	28-7700	Retainer Pivot Bracket	2
9	3290-415	Domed Head Rivet	22
10	36-2520	Seal — Bag R.H.	1
11	29-5540	Retainer — External Top	1
12	29-5550	Retainer — External Bag	2
13	32121-79	Pin — Roll	1
14	233-40	Grip — Handle	1
15	3269-4	Rivet — Domed Head	16
16	38-2920	Channel — Dump Handle	1
17	55-7270	Decal — Warning	1
18	28-7840	Screen — Bag	1
19	3256-61	Washer — Fender	8
20	62-4230	Retainer	1
21	36-2120	Grass Basket — Rear	1
22	36-2530	Seal — Bag L.H.	1
23	25-2200	Decal	1
24	5-1254	Washer	2
25	2830-10	Chain	2
26	28-7670	Frame — Bag Support	1
27	3290-355	Hair Pin Cotter	2
28	322-4	Capscrew — Hex Hd.	7
29	3256-23	Washer — Plain	9

Ref. No.	Part No.	Description	No. Used
30	322-2	Capscrew — Hex Hd.	2
31	3290-282	Rivet	5
32	28-7830	Frame Support Bracket	1
33	32152-1	Nut — Lock	2
34	28-7780	Support — Bag	1
35	56-7190	Bracket — Mounting Grass Catcher	2
36	3296-29	Nut — Lock	9
37	322-7	Capscrew — Hex Hd.	4
38	51-2970	Bracket — Mounting Grass Catcher	1
39	28-7820	Hanger — Frame Tower	1
40	32152-4	Nut — Lock	2
41	321-3	Capscrew — Hex Hd.	2
42	32103-14	Wing — Nut	2
43	3290-412	Rivet	4
44	33-2090	Bracket — Chute Support	1
45	3256-49	Washer	1
46	28-8050	Bracket — Chute Mounting	1
47	28-8130	Pin — Chute Locking	1
48	28-8070	Lanyard	1
49	28-8060	Chute Assembly (Incl. Ref. #31, 41-50)	1
50	54-9220	Decal — Danger	1
51	3229-1	Carriage Bolt	2
52	29-5470	Handle — Dump	1
53	28-7710	Bag — Frame	1

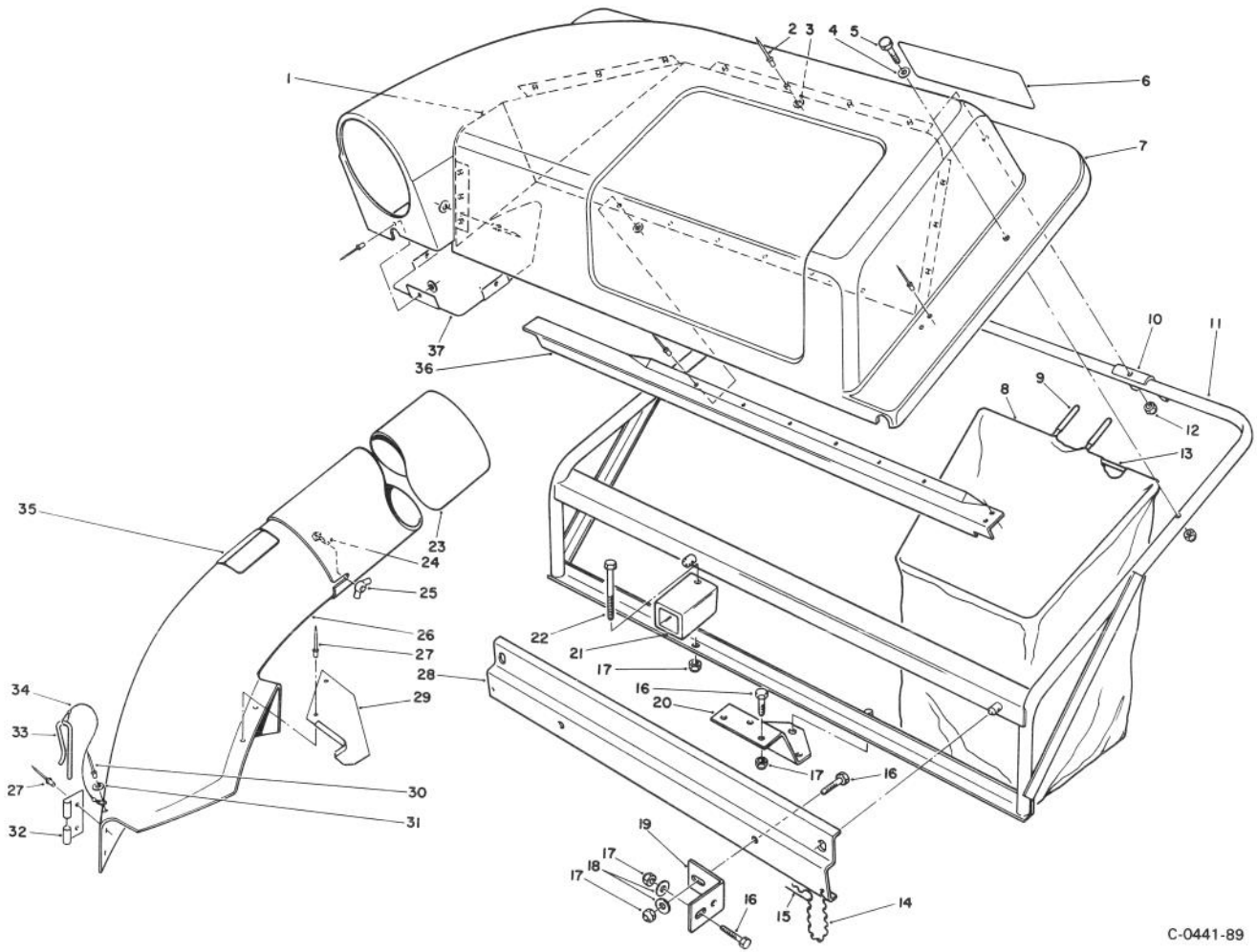

C-0441-89

TWIN BAGGER GRASS CATCHER MODEL NO. 59122 (Optional)

Ref. No.	Part No.	Description	No. Used
1	36-4230	Screen — Cover	1
2	3269-4	Rivet — Pop	23
3	3256-14	Washer — Plain	21
4	3256-23	Washer — Plain	4
5	322-7	Screw — Cap Hex. Hd.	4
6	47-6890	Decal — Twin Bagger	1
7	47-2190	Cover	1
8	47-2570	Bag — Twin Bagger	2
9	47-2550	Grip — Bag Handle	4
10	47-2580	Bracket — Bag Frame	2
11	47-2630	Frame	1
12	32111-8	Nut — Acorn	4
13	47-2620	Frame — Bag	2
14	2830-9	Chain	2
15	3290-355	Hair Pin Cotter	2
16	322-4	Capscrew	7
17	3296-29	Nut — Lock	8
18	3256-23	Washer — Flat	8
19	56-7190	Bracket — Mtg. Grass Catcher	2
20	51-2970	Plate — Mtg. Grass Catcher	1

Ref. No.	Part No.	Description	No. Used
21	51-2960	Tube — Frame Support	1
22	322-10	Screw — Cap Hex. Hd.	1
23	47-7210	Duct	1
24	3229-1	Carriage Bolt	2
25	32103-14	Nut — Wing	2
26	28-8060	Chute Assembly (Incl. Ref. #27, 29-35)	1
27	3290-412	Pop Rivet	4
28	36-4550	Bracket — Frame Support	1
29	33-2090	Bracket Chute Support	1
30	3290-282	Pop Rivet	1
31	3256-49	Washer — Plain	1
32	28-8050	Bracket Chute Mounting	1
33	28-8130	Pin — Chute Locking	1
34	28-8070	Lanyard	1
35	54-9220	Decal — Instruction Chute	1
36	47-2650	Bracket — Screen Support	1
37	47-6760	Shield — Cover	1
*	12-7039	Loose Parts	1

* Not Illustrated

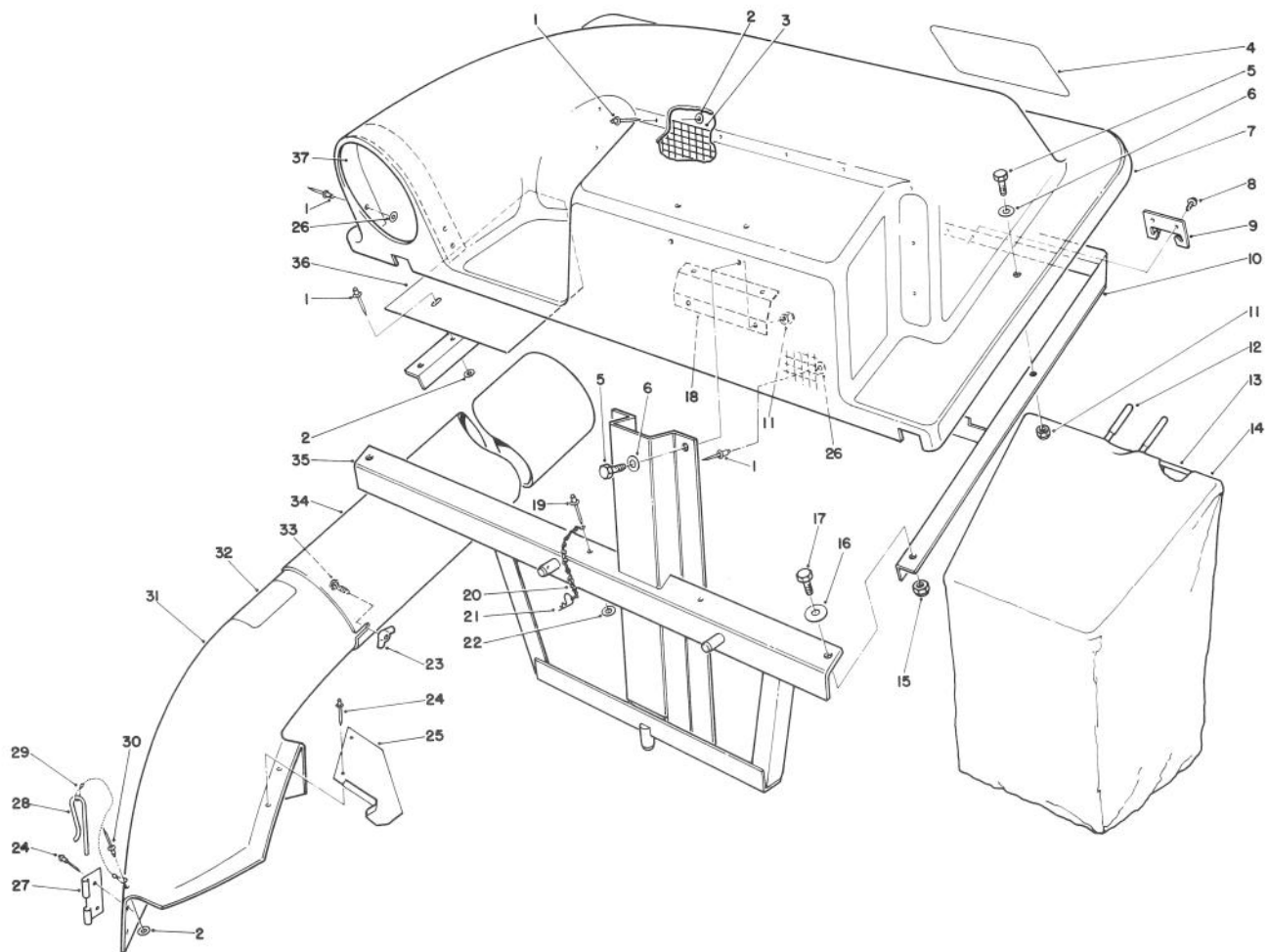

C-0442-89

TWIN BAGGER GRASS CATCHER MODEL NO. 59184 (Optional)

Ref. No.	Part No.	Description	No. Used
1	3269-4	Rivet — Pop	22
2	3256-49	Washer — Plain	12
3	61-9890	Screen	1
4	62-3640	Decal	1
5	322-5	Screw — Cap Hex. Hd.	8
6	3256-23	Washer — Plain	8
7	61-9790	Cover	1
8	32144-4	Screw — Hex Hd.	4
9	61-9860	Bracket — Bag Frame	2
10	61-9810	Cover — Frame W.A.	1
11	3296-29	Nut — Lock	8
12	47-2550	Grip — Bag Handle	4
13	47-2620	Frame — Bag	2
14	47-2570	Bag — Twin Bagger	2
15	3296-39	Nut — Lock	2
16	3256-24	Washer — Plain	2
17	323-6	Screw — Cap Hex. Hd.	2
18	61-9880	Plate — Back Up	1
19	3290-415	Rivet — Pop	2
20	2830-10	Chain	2

Ref. No.	Part No.	Description	No. Used
21	3290-355	Hairpin — Cotter	2
22	3269-10	Washer	2
23	32103-14	Nut — Wing	2
24	3290-412	Rivet — Pop	4
25	33-2090	Bracket — Chute Support	1
26	3256-14	Washer — Plain	10
27	28-8050	Bracket — Chute Mounting	1
28	28-8130	Pin — Chute Locking	1
29	28-8070	Lanyard	1
30	3290-282	Rivet — Pop	1
31	28-8060	Chute Assembly (Incl. Ref. #24-30 & 32)	1
32	54-9220	Decal — Instruction	1
33	3229-1	Carriage Bolt	2
34	47-7210	Duct	1
35	61-9900	Mounting Frame W.A.	1
36	61-9870	Baffle	1
37	62-6890	Support Inlet	1
*	12-7049	Loose Parts	1

* Not Illustrated

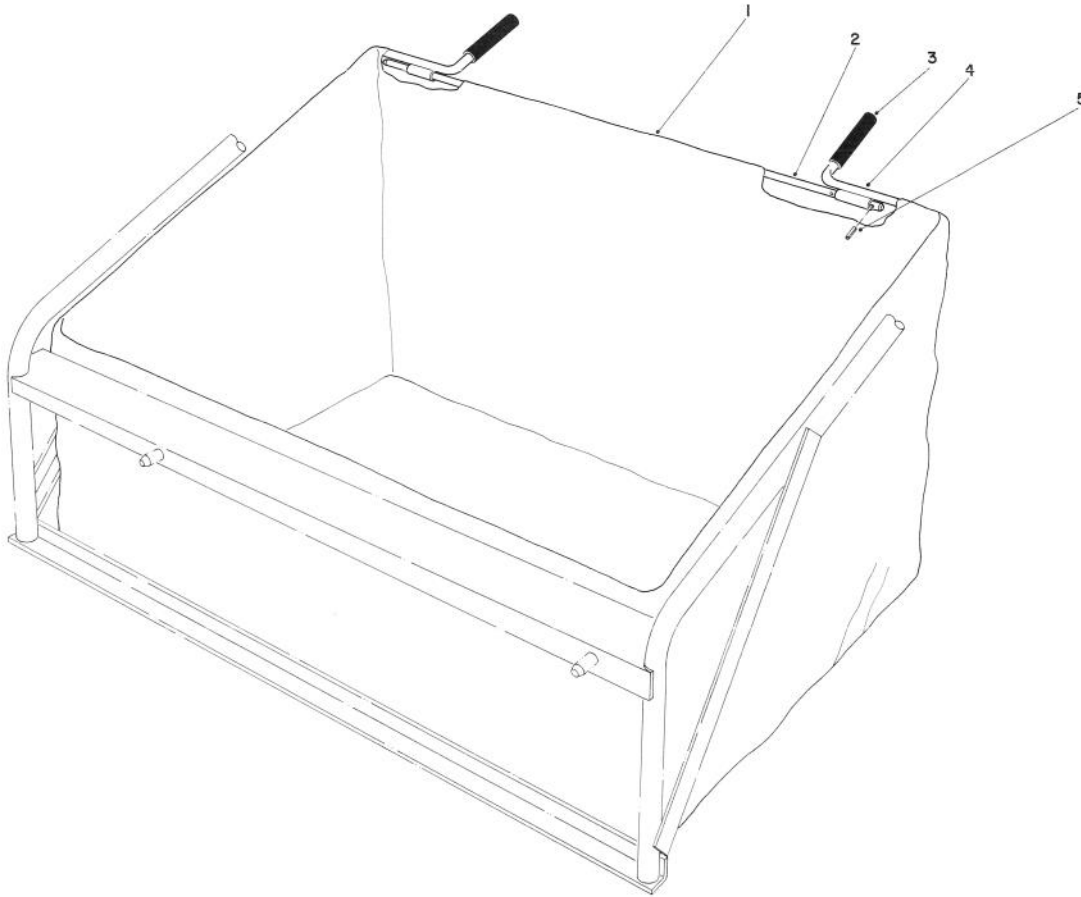

LEAF BAG MODEL 59123 (FOR USE ON TWIN BAGGER GRASS CATCHER MODEL NO. 59122 ONLY) (Optional)

C-0443-89

Ref. No.	Part No.	Description	No. Used
1	47-6860	Bag — Leaf Catcher	1
2	47-6800	Rod — Bag Frame	1
3	47-6710	Grip — Leaf Bag Handle	2

Ref. No.	Part No.	Description	No. Used
4	47-6830	Bag Frame	1
5	32121-73	Rollpin	2
*	505-78	Adhesive — Plastic	1

* Not Illustrated

309

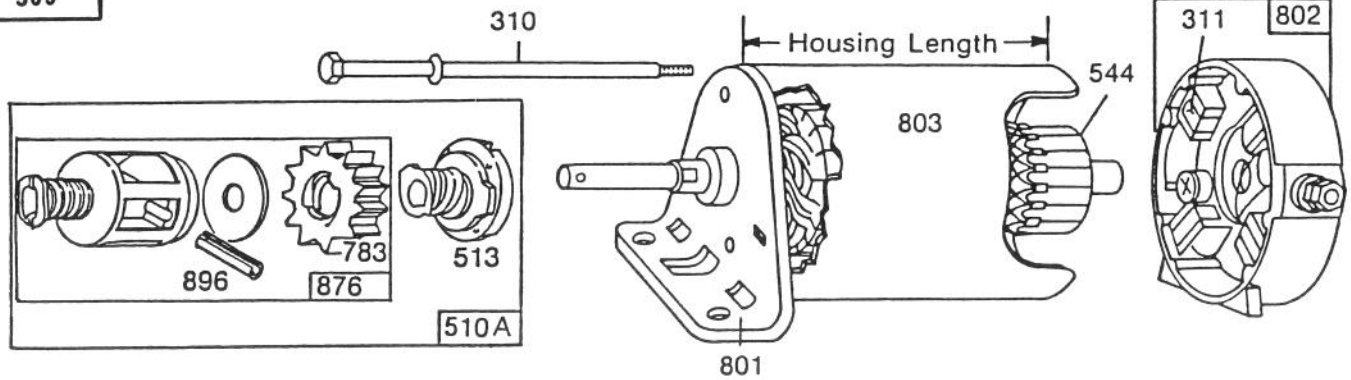

NOTE:

To identify Briggs & Stratton manufactured starter motors, measure the housing length.

ENGINE BRIGGS & STRATTON MODEL NO. 191707-2161-01

Ref. No.	Part No.	Description	No. Used
309	394805	Motor and Drive Assembly	1
310	94003	Thru Bolt Assembly	2
311	395538	Brush Assembly	2
510A	396865	Drive Assembly	1
513	391135	Clutch Assembly	1
544	392747	Armature Assembly	1
783	280104	Gear	1

Ref. No.	Part No.	Description	No. Used
801	394856	End Cap Assembly Drive	1
802	395537	End Cap Assembly Commutator	1
803	393825	Housing Assembly	1
876	393254	Retainer Kit	1
896	93754	Roll Pin	1

ENGINE BRIGGS & STRATTON MODEL NO. 191707-2161-01 (Continued)

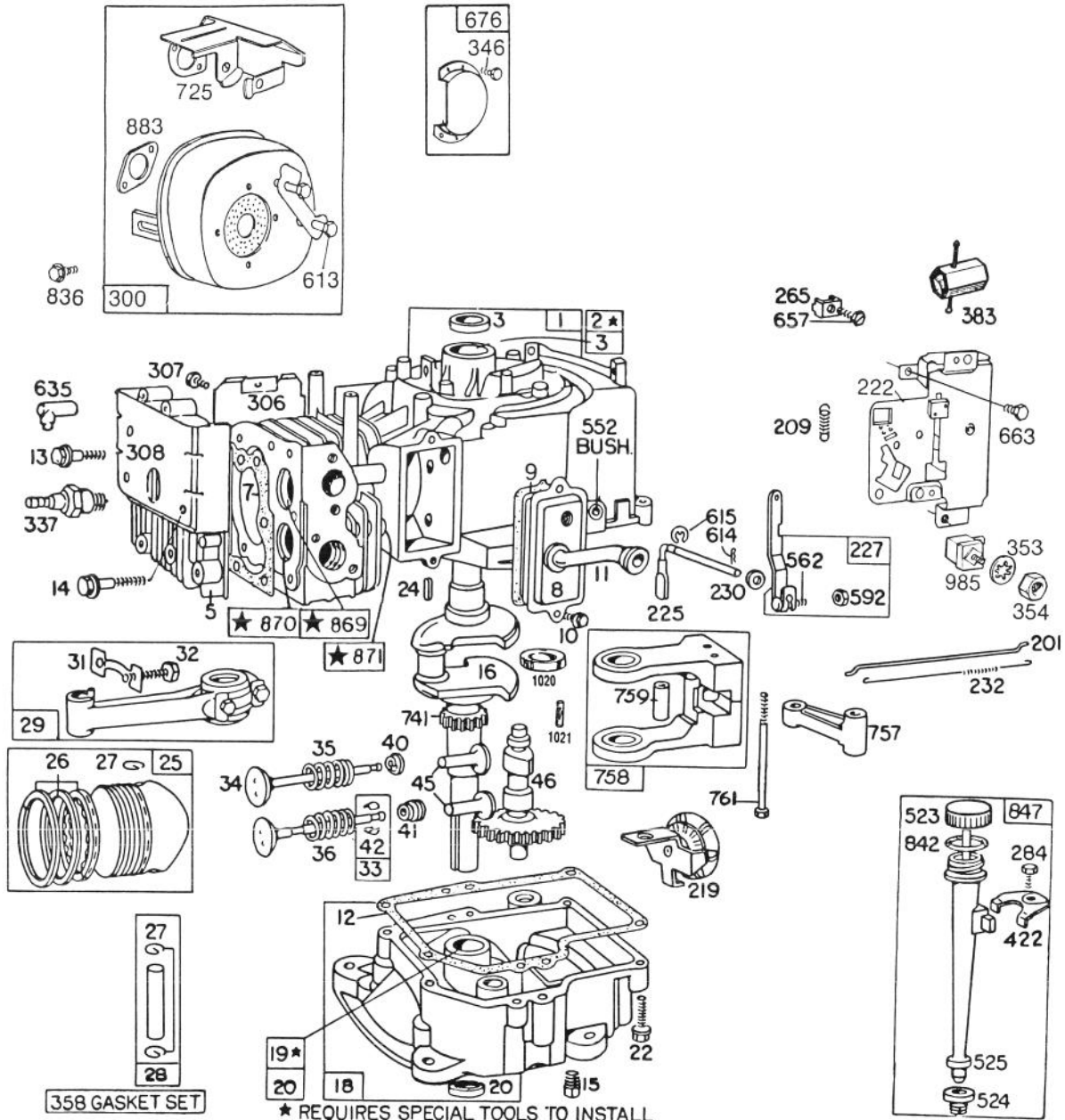

ENGINE BRIGGS & STRATTON MODEL NO. 191707-2161-01 (Continued)

Ref. No.	Part No.	Description	No. Used
1	396269	Cylinder Assembly	1
2	261960	Bearing — Cylinder Note: Requires special tools for installation.	1
3	294606	Seal — Oil	1
5	212286	Head — Cylinder	1
7	*270430	Gasket — Cylinder Head	1
8	299848	Breather Assembly	1
9	*27803	Gasket — Valve Cover	1
10	93394	Screw	1
11	280005	Tube — Breather	1
12	*27750	Gasket — Crankcase Cover, 1/64" thick	1
	*27876	Gasket — Crankcase Cover, .005" thick	1
	*27877	Gasket — Crankcase Cover, .009" thick	1
13	93211	Screw — Cylinder Head (2-21/32" long)	1
14	93723	Screw — Cylinder Head (3" long)	1
15	91084	Plug — Oil Drain	1
16	396876	Crankshaft Note: Order Part 230978 for Timing Gear Pin Replacement.	1
18	392548	Base — Oil	1
19	295963	Bushing — Oil Base Note: Requires special tools for installation.	1
20	391086	Seal — Oil	1
22	93585	Screw — Base Mtg.	1
24	222698	Key — Flywheel	1
25	391673	Piston Assy. — Std.	1
	391674	Piston Assy. — .010" O.S.	1
	391675	Piston Assy. — .020" O.S.	1
	391676	Piston Assy. — .030" O.S.	1
		Piston Ring Sets Note: For Chrome Piston Ring Set — Standard Size — Order No. 299743.	
26	391669	Ring Set — Piston, Std.	1
	391670	Ring Set — Piston, .010" O.S.	1
	391671	Ring Set — Piston, .020" O.S.	1
	391672	Ring Set — Piston, .030" O.S.	1
27	68546	Lock — Piston Pin	1
28	295840	Pin Assy. — Piston, Std.	1
	295841	Pin Assy. — Piston, .005" O.S.	1
29	390402	Rod Assy. — Connecting Note: For Connecting Rod with .020" Undersize Crankpin Bore — Order No. 390773.	1
31	222114	Lock — Conn. Rod Screw	1
32	92659	Screw — Conn. Rod	1
33	390419	Valve — Exhaust	1
34	261055	Valve — Intake	1
35	65906	Spring — Intake Valve	1
36	26828	Spring — Exhaust Valve	1
40	221596	Retainer — Intake Valve	1
41	292260	Rotocoil — Exhaust Valve	1
42	93630	Retainer — Exhaust Valve Rotocoil	2

Ref. No.	Part No.	Description	No. Used
45	260933	Tappet — Valve	1
46	211689	Gear — Cam	1
201	261611	Link — Governor	1
209	260871	Spring — Governor	1
219	392718	Oil Slinger — Gov. Gear and Bracket Assembly	1
222	390784	Plate — Gov. Control	1
225	231058	Crank — Governor (1/4" Dia.)	1
227	391733	Lever Assy. — Governor For 1/4" Dia. Crank	1
230	222450	Washer — Gov. Lever (1/4" I.D.)	1
232	261911	Spring — Governor Link	1
265	221535	Clamp — Casing	1
284	93804	Screw — Clamp Mtg.	1
300	398507	Muffler — Exhaust	1
306	222830	Shield — Cylinder	1
307	93163	Screw — Cylinder Shield Mtg.	1
308	222636	Cover — Cylinder Head	1
337	293918	Plug — Spark (1-1/2" high — 37-42 M.M.) (Resistor Type)	1
346	93705	Screw	1
353	92791	Washer — Lock	3
354	90576	Nut — Hex	2
358	299577	Gasket Set	1
383	89838	Spark Plug Wrench	1
422	222502	Clamp — Oil Filler Tube	1
523	391840	Cap and Dipstick — Oil Filler	1
524	68838	Seal — Filler Tube	1
525	280133	Tube — Oil Filler	1
552	231055	Bushing — Gov. Crank (1/4" I.D.)	1
562	92613	Bolt — Governor Lever	1
592	231082	Nut — Hex	1
613	94042	Screw — Muffler	1
614	93306	Cotter — Hair Pin	1
615	93307	Retainer — E-Ring	1
635	66538	Elbow — Spark Plug	1
657	93496	Screw	1
663	93572	Screw	1
676	395700	Deflector — Exhaust (Direct Out)	1
725	223540	Shield — Muffler	1
741	261195	Gear — Timing	1
757	212359	Link — Counterweight	1
758	390172	Counterweight Assy.	1
759	298909	Pin — Counterweight	1
761	93874	Screw — Counterweight	1
836	93559	Screw	1
842	270920	Seal — Filler Cap	1
847	392066	Filler Group — Oil	1
869	211661	Seat — Intake Valve (Std.)	1
870	211661	Seat — Exhaust Valve (Std.)	1
871	231218	Guide — Exhaust or Intake Valve See Repair Manual	1
883	270918	Gasket — Exhaust Pipe	1
985	398525	Insulator Assembly	1
1020	261190	Eccentric	1
1021	94160	Pin — Eccentric	1

* Included in Gasket Set — Part No. 299577.

ENGINE BRIGGS & STRATTON MODEL NO. 191707-2161-01 (Continued)

Ref. No.	Part No.	Description	No. Used
23	391983	Flywheel and Ring Gear Assy. — Magneto	1
52	†270538	Gasket — Carburetor Mtg.	1
75	220865	Washer — Spring	1
78	93805	Screw — Sem	1
94	†292681	Valve Assembly — Carburetor Idle	1
95	93499	Screw — Throttle and Choke Valve Mtg.	1
98	91920	Screw — Machine, Fill. Hd.	1
99	26157	Spring — Throttle Adjustment	1
101	93043	Pin — Throttle Stop	1
104	†230896	Pin — Float Hinge	1
108	222010	Valve — Choke	1
118	†396568	Valve — Needle	1
121	394698	Carburetor Overhaul Kit	1
123	93357	Screw — Carburetor Mtg.	1
125	390811	Carburetor Assembly	1
126	299851	Body Assembly Carburetor	1
127	†221997	Plug — Welch	1
128	211682	Venturi — Carburetor	1
130	221986	Valve — Throttle	1
131	490017	Shaft and Lever — Throttle	1
132	211712	Stop — Throttle	1
133	299707	Float — Carburetor	1
134	†394681	Valve — Fuel Inlet	1
136	221995	Bowl — Float	1
137	†270511	Gasket — Float Bowl	1
138	†222014	Washer — Float Bowl	1
141	390684	Shaft and Lever — Choke	1
142	†299740	Nozzle — Carburetor	1
147	†231323	Screw — Nozzle	1
198	293934	Valve — Fuel Shut-Off	1
199	390303	Connector — Fuel Pipe	1
200	221760	Guide — Air	1

Ref. No.	Part No.	Description	No. Used
216	261612	Link — Choke	1
304	299392	Housing — Blower	1
305	93158	Screw — Blower Housing Mounting	1
332	92284	Nut — Flywheel	1
333	398811	Armature Magneto	1
334	93381	Screw — Armature Mtg.	1
356	398808	Wire Ground	1
363	19165	Puller — Flywheel	1
455	222561	Cup — Screen Mounting	1
468	222562	Screen — Flush Rotating	1
482	93621	Screw	1
527	221428	Clamp	2
534	93622	Screw — Air Cleaner	1
534A	93323	Screw — Air Cleaner	1
535	270528	Element — Air Cleaner	1
536	390379	Cleaner Assy. — Air	1
537	270539	Gasket — Air Cleaner	1
618	261116	Spring — Choke Return	1
634	270382	Washer — Choke Shaft	1
643	222149	Cup — Air Cleaner	1
662	222027	Bracket — Carburetor	1
663	93572	Screw	1
683	93572	Screw	1
726	392134	Gear — Ring (Aluminum) (Includes Mtg. Parts)	1
851	221798	Terminal — Ignition Cable	1
877	393814	Diode and Connector Assy.	1
887	391529	Stator Assembly — Alternator (D.C.)	1
917	223271	Valve Handle — Fuel Shut-Off	1
952	222495	Spacer — Air Cleaner	1
953	222022	Screen — Air Cleaner	1
987	398970	Seal — Throttle	1

† Included in Carburetor Overhaul Kit — Part No. 394698.

PRODUCT CHANGES

In an effort to make improvements available to TORO owners as quickly as possible, minor changes are incorporated into Toro's products from time to time that do not become immediately shown in the Parts Catalog. If such a change apparently has been made in your unit, which is not reflected in your manual, see your TORO Distributor or his Authorized TORO Service Dealer for information and part numbers.

IDENTIFICATION AND ORDERING

MODEL AND SERIAL NUMBERS

The Rider has two identification numbers: a model number and a serial number. The two numbers are stamped on a decal which is located on the left side of frame in front of rear wheel. In any correspondence concerning the Rider, supply model and serial numbers to assure that correct information and replacement parts are obtained.

To order replacement parts from an Authorized TORO Service Dealer, supply the following information:

1. Model and serial numbers of the Rider.
2. Part number, description, and quantity of part(s) desired.

Note: Do not order by reference number if a parts catalog is being used; use the PART NUMBER.

The Toro Promise

A Two Year Limited Warranty

On All

Gasoline Powered Consumer Products

The Toro Company promises to repair your TORO Product if defective in materials or workmanship. The following time periods from the date of purchase apply:

Residential Product 2 Years
Residential Products Used Commercially 90 Days

The costs of parts and labor are included, but the customer pays the transportation costs. Just return any residential product to an Authorized TORO Service Dealer or TORO Distributor.

Should you feel your TORO Product is defective and wish to rely on The Toro Promise, the following procedure is recommended:

1. Contact any Authorized TORO Service Dealer, TORO Master Service Dealer, or TORO Distributor (the Yellow Pages of your telephone directory is a good reference source).
2. He will either instruct you to return the product to him or recommend another Authorized TORO Service outlet which might be more convenient.
3. Bring the product along with your original sales slip, or other evidence of purchase date, to the service dealer.
4. The servicing dealer will inspect the unit, advise you whether the product is defective and, if so, make all repairs necessary to correct the defect without extra charge to you.

If for any reason you are dissatisfied with the dealer's analysis of the defect or the service performed, you may contact us.

Write:

TORO Consumer Service Department
8111 Lyndale Avenue South
Minneapolis, Minnesota 55420

The above remedy of product defects through repair by an Authorized TORO Service Dealer is the purchaser's sole remedy for any defect.

THERE IS NO OTHER EXPRESS WARRANTY. ALL IMPLIED WARRANTIES OF MERCHANTABILITY AND

FITNESS FOR USE ARE LIMITED TO THE DURATION OF THE EXPRESS WARRANTY.

Some states do not allow limitations on how long an implied warranty lasts, so the above limitation may not apply to you.

This warranty applies only to parts or components which are defective and does not cover repairs necessary due to normal wear, misuse, accidents, or lack of proper maintenance. Regular, routine maintenance of the unit to keep it in proper operating condition is the responsibility of the owner.

All warranty repairs reimbursable under The Toro Promise must be performed by an Authorized TORO Service Dealer using Toro approved replacement parts.

Repairs or attempted repairs by anyone other than an Authorized TORO Service Account are not reimbursable under The Toro Promise. In addition, these unauthorized repair attempts may result in additional malfunctions, the correction of which is not covered by warranty.

THE TORO COMPANY IS NOT LIABLE FOR INDIRECT, INCIDENTAL OR CONSEQUENTIAL DAMAGES IN CONNECTION WITH THE USE OF THE PRODUCT INCLUDING ANY COST OR EXPENSE OF PROVIDING SUBSTITUTE EQUIPMENT OR SERVICE DURING PERIODS OF MALFUNCTION OR NON-USE.

Some states do not allow the exclusion or limitation of incidental or consequential damages, so the above limitation or exclusion may not apply to you.

This warranty gives you specific legal rights, and you may also have other rights which vary from state to state.

COUNTRIES OTHER THAN THE UNITED STATES OR CANADA

Customers who have purchased TORO products exported from the United States or Canada should contact their TORO Distributor (Dealer) to obtain guarantee policies for your country, province or state. If for any reason

you are dissatisfied with your Distributor's service or have difficulty obtaining guarantee information, contact the TORO importer. If all other remedies fail, you may contact us at The Toro Company.