

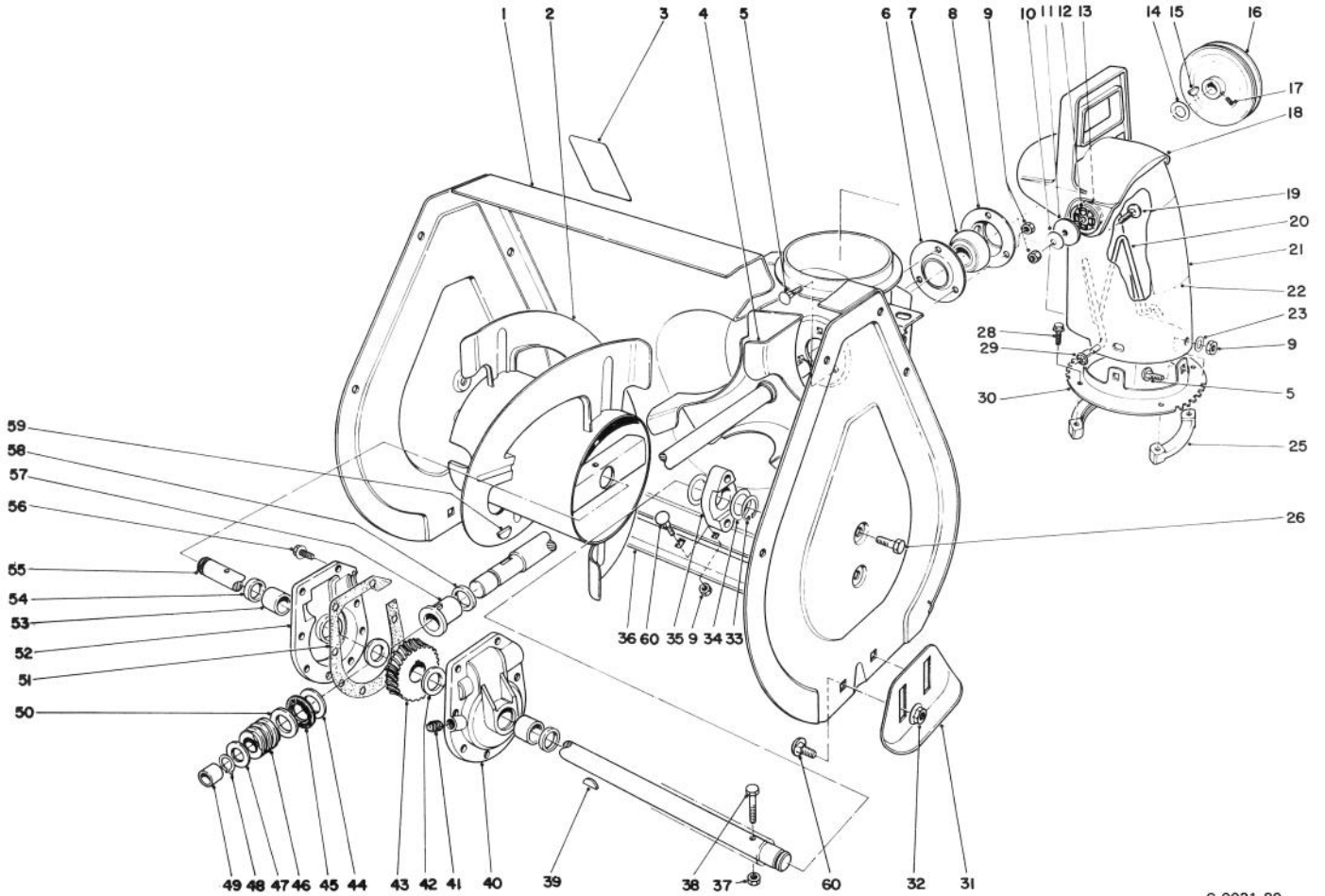

MODEL NO. 38052-900001 & UP
 MODEL NO. 38052C-9900001 & UP

**PARTS
 CATALOG**

521 SNOWTHROWER



C-0031-89

AUGER ASSEMBLY

Ref. No.	Part No.	Description	No. Used
1	11-5269	Housing — Auger (Incl. Ref. #3 & 27)	1
2	39-1180	Auger — R.H.	1
*	39-1190	Auger — L.H.	1
3	53-7670	Decal — Auger Warning	1
4	37-6990	Shaft & Impeller	1
5	3230-18	Carriage Bolt	6
6		Flange Bearing — Front	1
7	63-3450	Bearing — Ball	1
8		Flange Bearing — Rear	1
9	3296-29	Locknut	13
10	3290-340	Washer — Belleville	2
11	3256-68	Washer — Flat	2
12	55-8950	Plate — Friction	2
13	20-4320	Washer — Rubber	2

Ref. No.	Part No.	Description	No. Used
14	3-0737	Washer — Flat	1
15	3257-5	Key	1
16	37-6890	Pulley	1
17	3242-4	Screw — Set	2
18	56-2680	Deflector	1
19	3230-22	Carriage Bolt	2
20	56-2670	Wire — Chute	1
21	12-8289	Chute Discharge (Incl. Ref. #22) (Model 38052)	1
21	12-8749	Chute Discharge (Incl. Ref. #22) (Model 38052C)	1
22	63-3740	Decal Discharge (Model 38052)	1
22	63-3760	Decal Discharge (Model 38052C)	1

* Not Illustrated

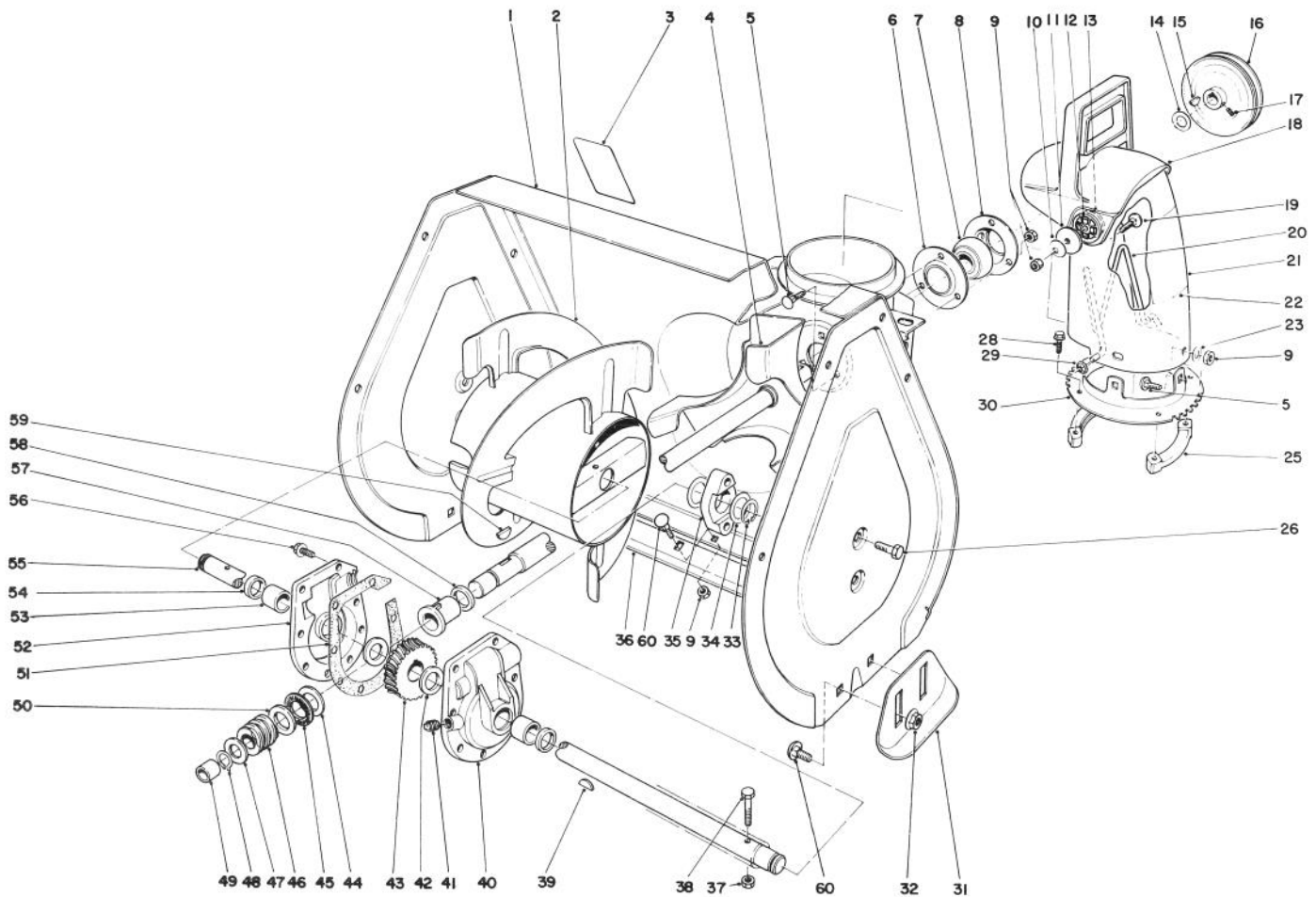

C-0031-89

AUGER ASSEMBLY (Continued)

Ref. No.	Part No.	Description	No. Used
23	3256-23	Washer — Flat	3
25	37-6490	Retainer — Chute Ring	3
26	32144-70	Hex Hd. Self Tap. Screw	4
28	27-0220	Hex Hd. Self Tap. Screw	6
29	3290-326	Nut — Push	1
30	37-8941	Ring — Chute	1
31	40-8160	Skid	2
32	32128-20	Flange Nut	4
33	32151-36	Ring — Snap	2
34	5-1550	Washer — Thrust	4
35	37-6550	Bearing — Auger	2
36	39-1550	Blade — Scraper	1
37	3296-42	Locknut	2
38	321-10	Hex Hd. Capscrew	2
39	3257-33	Key — Woodruff	1
40	37-8860	Gear Case — L.H. (Incl. Ref. #53 & 54)	1
41	281-1	Plug — Pipe	1
42	252-71	Bearing — Thrust	2
43	23-9050	Gear	1

Ref. No.	Part No.	Description	No. Used
44	257-3	Washer — Thrust	1
45	252-76	Bearing — Needle Thrust	1
46	5-7170	Worm	1
47	3-8664	Washer	1
48	32120-72	Ring — Retaining	1
49	256-32	Bushing	1
50	252-80	Washer — Thrust	1
51	51-0460	Gasket	1
52	37-8850	Gear Case — R.H. (Incl. Ref. #53 & 54)	1
53	256-237	Bushing	2
54	7-0045	Seal — Oil	2
55	37-6800	Shaft — Auger	1
56	32144-41	Hex Hd. Self Tap Screw	8
57	37-6560	Bushing — Input	1
58	237-87	Seal	1
59	3257-23	Key — Woodruff	1
60	3230-1	Carriage Bolt	9
*	37-6960	Gear Case Assembly Complete	1
*	12-8789	Bearing Assy. (Incl. Ref. #6-8)	1

* Not Illustrated

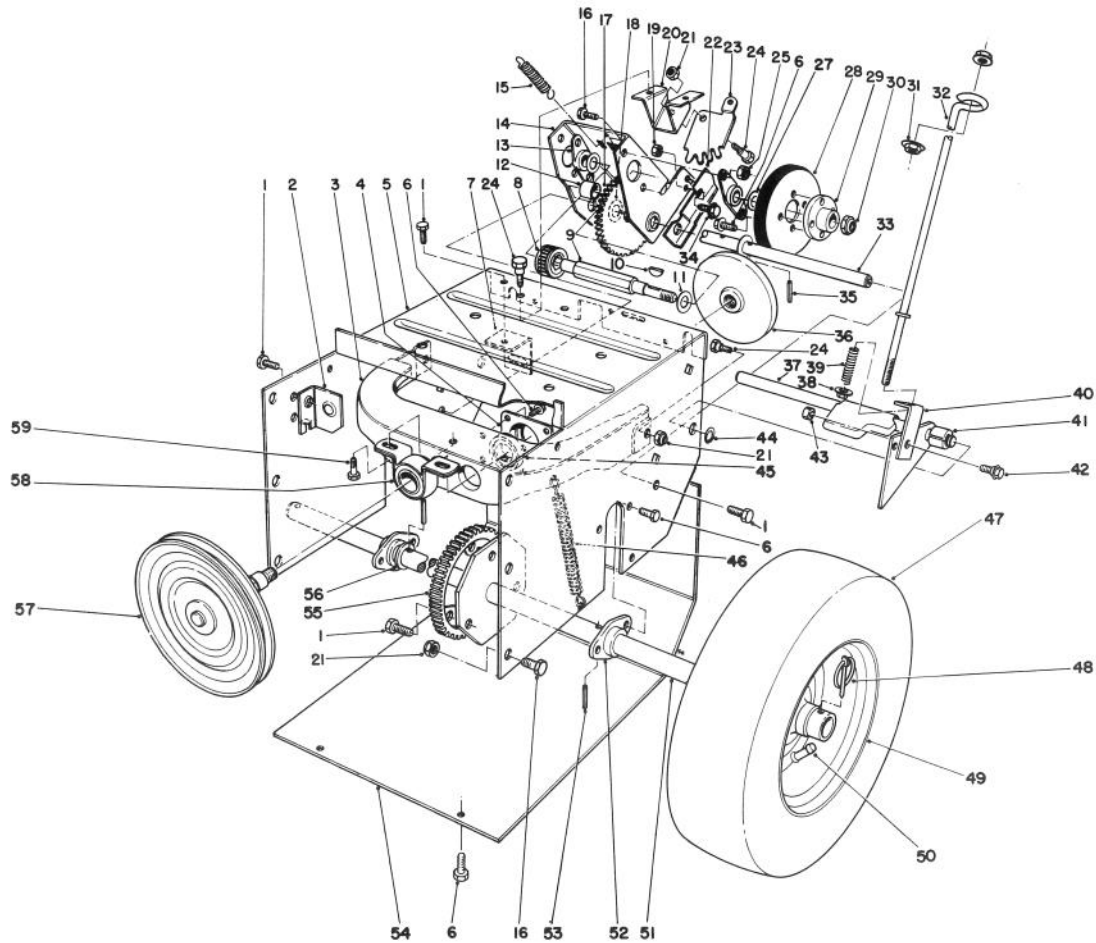

C-0032-89

TRACTION ASSEMBLY

Ref. No.	Part No.	Description	No. Used
1	32144-70	Hex Hd. Self Tap. Screw	9
2	37-9060	Mount — Clutch Rod Front	1
3	37-6740	Frame — Friction Plate	1
4	37-6730	Cup — Bearing	1
5	37-8900	Frame — Traction	1
6	32144-4	Hex Hd. Self Tap. Screw	16
7	37-9070	Mount — Clutch Rod Rear	1
8	37-6500	Gear — Sliding	1
9	37-6780	Shaft — Hex	1
10	3257-24	Key	1
11	5-7570	Washer — Thrust	2
12	256-86	Bushing	1
13	20-1620	Bearing — Friction Wheel	2
14	39-1230	Bracket — Sliding	1
15	37-8880	Spring — Traction Engage	1
16	322-2	Hex Hd. Capscrew	10
17	37-9160	Intermediate Gear & Bushing (Incl. Ref. #12)	1
18	10-9280	Washer — Thrust	2
19	3296-16	Locknut	1
20	37-8790	Mount — Quadrant Gear	1
21	3296-29	Locknut	9
22	39-1250	Cam — Receiver	1
23	37-8800	Quadrant — Gear	1
24	37-8770	Shoulder Bolt	3
25	3296-29	Locknut	4
27	36-4790	Washer — Thrust	2
28	37-6570	Wheel — Friction	1
29	39-1520	Hub — Friction Wheel Mount	1
30	3296-48	Locknut	1
31	32128-33	Flange Locknut	2

Ref. No.	Part No.	Description	No. Used
32	39-3060	Rod — Lower Traction	1
33	37-6760	Shaft — Pivot	1
34	321-4	Screw — Hex Hd.	1
35	32121-45	Roll Pin	2
36	38-0800	Plate — Friction	1
37	43-7310	Traction Engagement Assy.	1
38	32128-32	Flange Locknut	1
39	38-4520	Spring — Compression	1
40	38-4490	Bracket — Traction	1
41	40-9680	Spacer	1
42	40-8350	Screw — Shoulder	1
43	3296-42	Locknut	1
44	32151-61	Ring — Retaining	1
45	38-7820	Bearing	1
46	37-8870	Spring — Friction Plate Frame	1
47	231-125	Tire	2
48	3290-243	Pin — Klik	2
49	241-126	Rim	2
50	232-49	Tube	2
51	37-6970	Shaft — Axle	1
52	37-6850	Bearing — Axle	2
53	32121-31	Roll Pin	2
54	37-6830	Cover — Bottom	1
55	37-6520	Gear — Axle	1
56	3-8664	Washer — Thrust	2
57	40-8190	Pulley & Shaft	1
58	38-4470	Bushing Assembly	1
59	32144-11	Hex Hd. Self Tap. Screw	2
*	62-7630	Tire Chain Kit (Optional)	1
*	12-4479	Loose Parts	1

* Not Illustrated

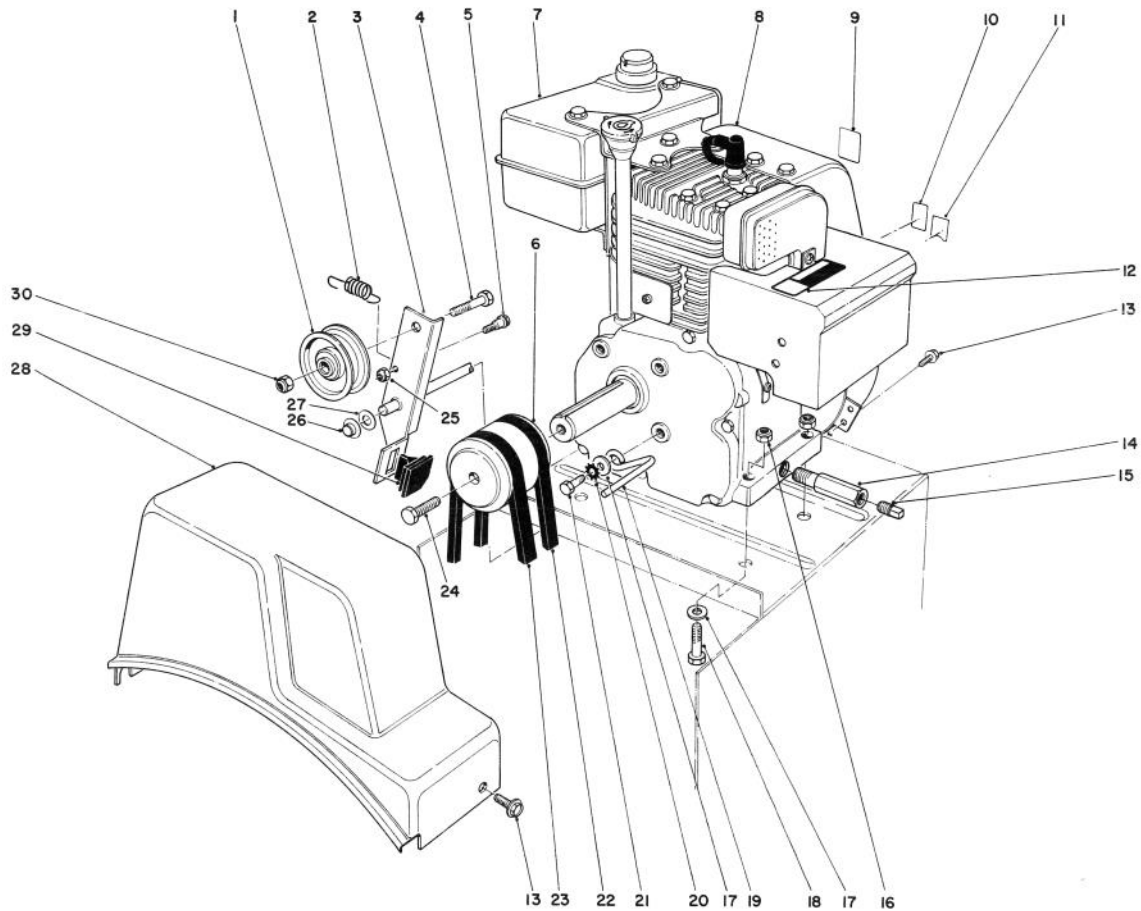

C-0038-89

ENGINE ASSEMBLY

Ref. No.	Part No.	Description	No. Used
1	3-4244	Idler Pulley	1
2	53-7570	Spring — Auger Disengage	1
3	8-8649	Auger Clutch (Incl. Ref. #29)	1
4	323-29	Capscrew	1
5	42-3560	Bolt — Shoulder	1
6	43-7370	Engine Pulley	1
7	52-2680	Gas Tank w/Cap	1
8		Engine	1
9	62-5760	Decal — Primer	1
10	63-2450	Decal — Throttle	1
11	39-3850	Decal — Choke (Model 38052)	1
11	63-2410	Decal — Choke (Model 38052C)	1
12	62-7290	Decal — Hot Surface Warning (Model 38052)	1
12	63-2310	Decal — Hot Surface Warning (Model 38052C)	1

Ref. No.	Part No.	Description	No. Used
13	32144-4	Self Tapping Screw	3
14	49-3040	Drain Tube	1
15	281-7	Pipe Plug	1
16	3296-29	Locknut	4
17	3256-23	Flat Washer	5
18	322-7	Capscrew	4
19	37-8990	Belt Retainer	1
20	3255-8	Lockwasher — External Tooth	1
21	3210-3	Capscrew	1
22	37-9090	V-Belt — Traction	1
23	37-9080	V-Belt — Auger	1
24	43-7290	Screw — Special	1
25	3296-56	Locknut	1
26	3290-320	Nut — Push On	1
27	3256-24	Flat Washer	1
28	37-6900	Belt Cover	1
29	66-8060	Molded Brake Assembly	1
30	3296-59	Locknut	1

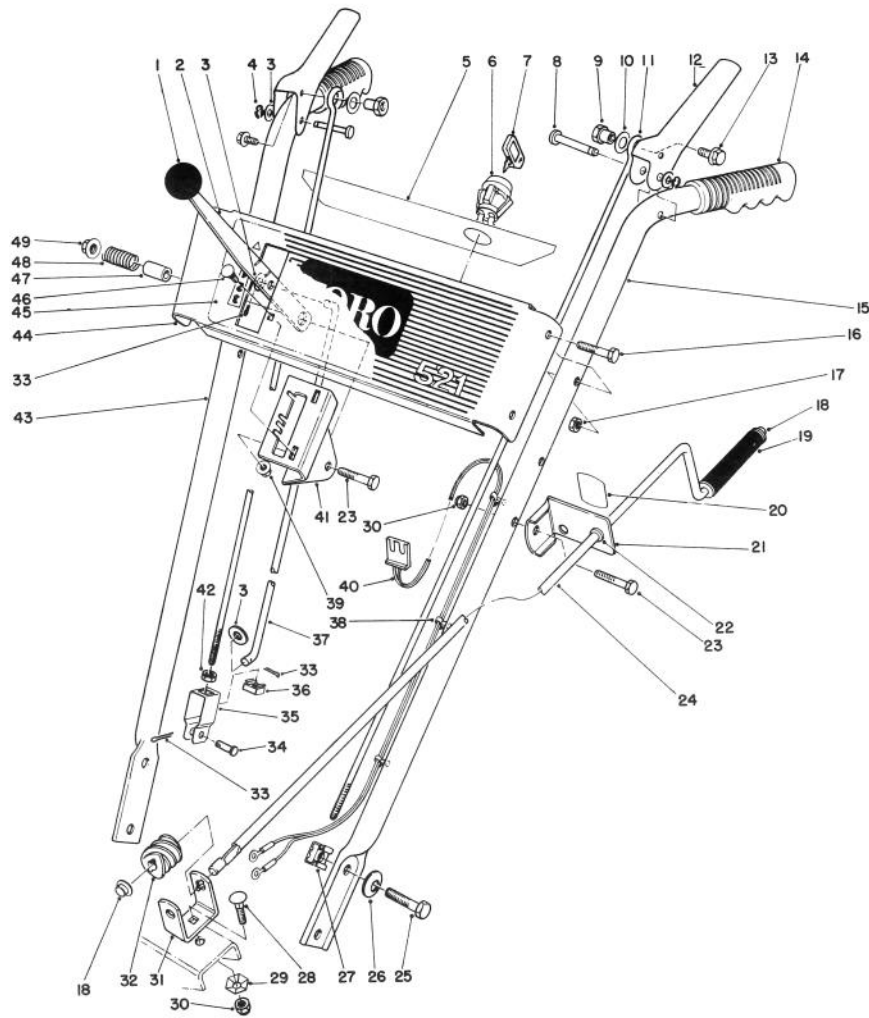

C-0039-89

HANDLE ASSEMBLY

Ref. No.	Part No.	Description	No. Used
1	233-21	Knob	1
2	37-8820	Selector — Speed	1
3	3256-23	Washer	4
4	32151-73	Ring — Clip	2
5	63-3530	Decal — Escutcheon Back (Model 38052)	1
5	63-3540	Decal — Escutcheon Back (Model 38052C)	1
6	40-5940	Switch — On-Off	1
7	62-7770	Key — Ignition	1
8	52-5600	Pin — Control Lever	2
9	47-4990	Post — Linkage Mounting	2
10	3256-24	Washer	2
11	52-5590	Link — Upper	2
12	63-3640	Handle — Control	2
13	3234-13	Screw — Hex Flange Hd.	2
14	37-9110	Grip — Handle	2
15	52-5570	Handle — Left	1
16	321-9	Screw — Hex Hd.	4
17	3246-42	Nut — Lock	4
18	3290-320	Nut — Push	2
19	66-6540	Grip — Rod	1
20	63-3510	Decal — Chute Direction	1
21	12-7739	Bracket — Chute Control (Incl. Ref. #20 & 22)	1
22	256-249	Nyliner	1
23	322-7	Screw — Hex Hd.	2
24	40-8270	Rod — Chute Control	1

Ref. No.	Part No.	Description	No. Used
25	322-2	Screw — Cap Hex Hd.	4
26	3290-456	Washer — Belleville	4
27	3290-196	Nut — Retainer	4
28	3230-2	Bolt — Carriage	1
29	3290-238	Washer — Pyramidal	1
30	3296-29	Nut — Lock	2
31	40-8280	Bracket — Chute Worm	1
32	40-8250	Gear — Worm	1
33	3272-4	Pin — Cotter	3
34	283-3	Pin — Clevis	1
35	39-3080	Clevis	1
36	32115-5	Nut — Retainer	1
37	39-7570	Rod — Speed Selector	1
38	17-9120	Mount — Wire	3
39	32128-32	Nut — Flange Lock	2
40	43-7390	Wire Harness Assembly (Incl. Ref. #38)	1
41	39-1280	Mount — Speed Selector	1
42	3218-1	Nut — Jam	1
43	52-5560	Handle — Right	1
44	43-7360	Panel — Escutcheon	1
45	66-6560	Decal — 521	1
46	3229-22	Bolt — Carriage	2
47	40-8130	Spacer — Speed Selector	1
48	37-9150	Spring	1
49	32128-13	Nut — Flange Lock	1
*	3290-378	Cable Tie	2

* Not Illustrated

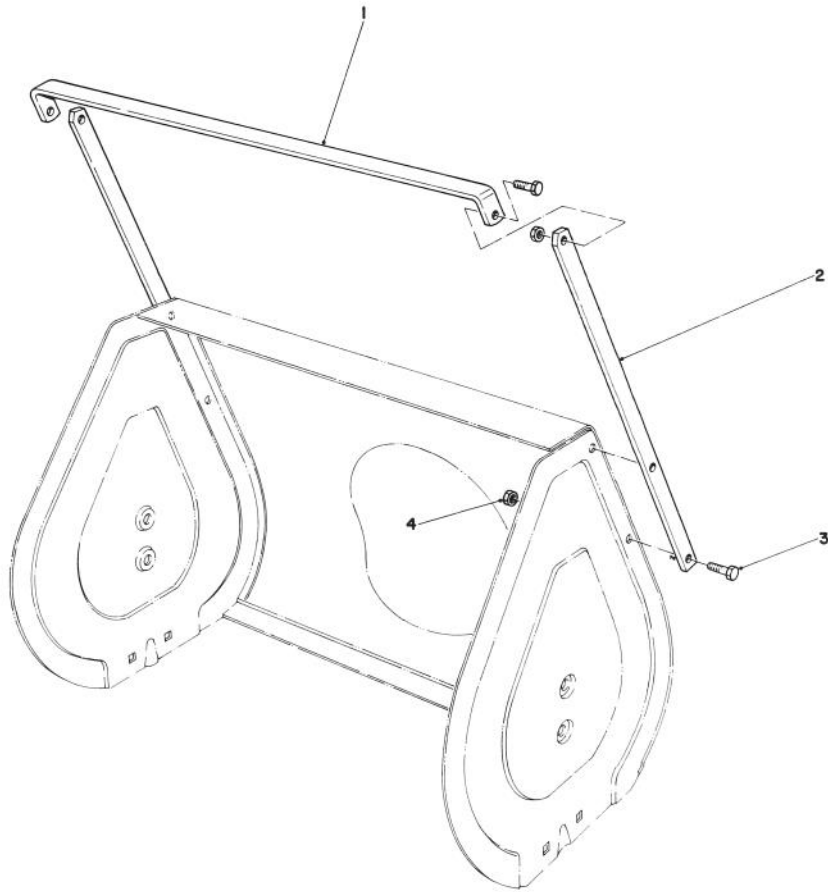

C-0035-89

DRIFT BREAKER KIT NO. 37-7020 (Optional)

Ref. No.	Part No.	Description	No. Used
1	38-0760	Drift Breaker — Top	1
2	38-0750	Drift Breaker — Side	2

Ref. No.	Part No.	Description	No. Used
3	322-4	Capscrew	6
4	3296-29	Locknut	6

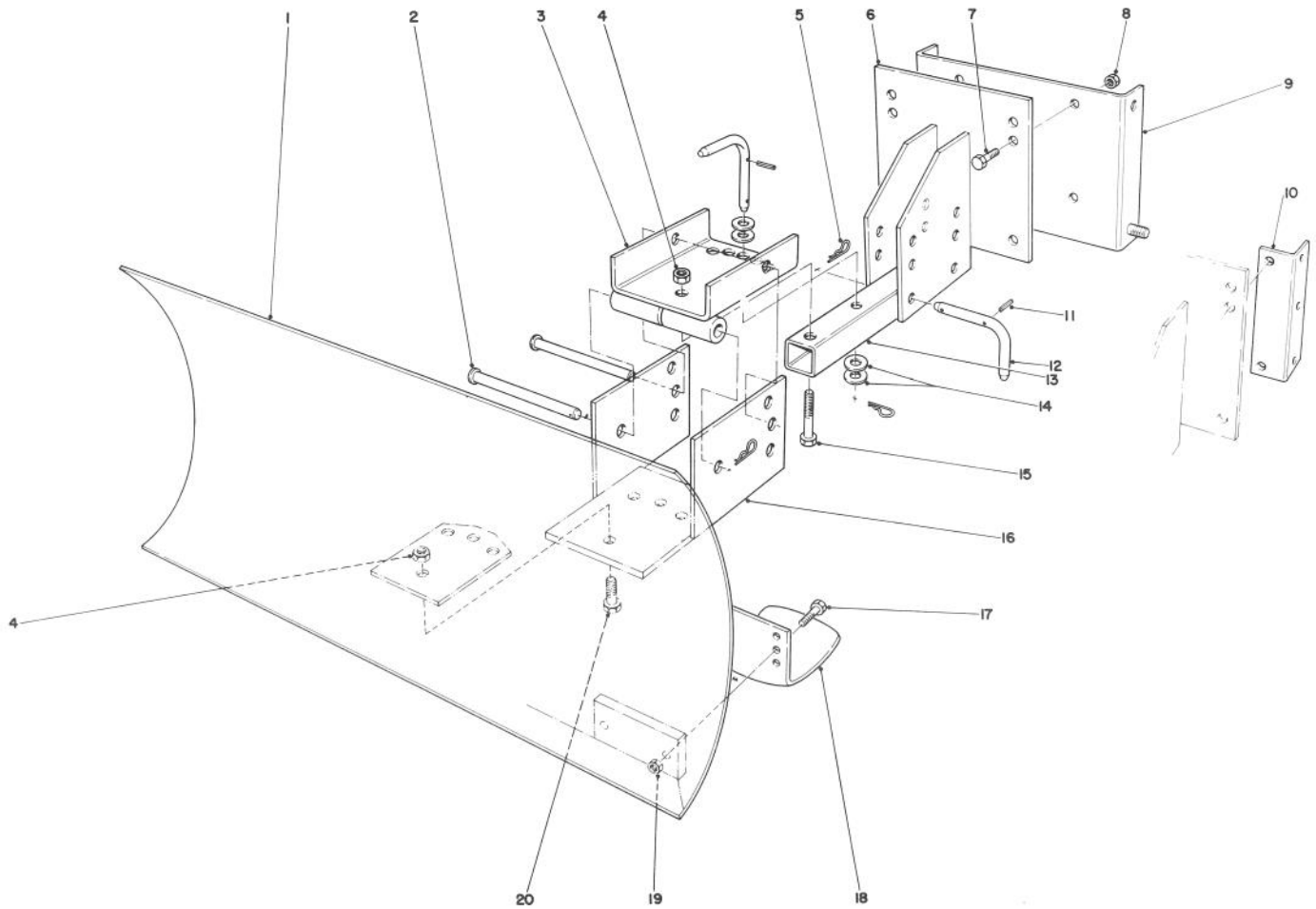

C-0036-89

GRADER BLADE ASSEMBLY MODEL 59099 (Optional)

Ref. No.	Part No.	Description	No. Used
1	7-4374	Blade	1
2	283-38	Clevis Pin	2
3	20-5090	Swivel Bracket	1
4	32152-3	Locknut	5
5	3290-322	Hairpin Cotter	5
6	20-5170	Mounting Plate	1
7	323-6	Capscrew	4
8	32152-2	Locknut	4
9	22-4920	Mounting Plate Bracket (Used with 826 and 1132 only)	1
10	39-7850	Mounting Rail (Used with 3521 & 521 Units only)	2
11	32121-45	Roll Pin	3
12	20-5210	Pivot Pin (Incl. Ref. #11)	3
13	20-5140	Tongue Blade	1

Ref. No.	Part No.	Description	No. Used
14	3256-5	Flat Washer	4
15	325-11	Capscrew	1
16	20-5130	Blade Adjustment	1
17	322-6	Capscrew	4
18	7-1023	Skid	2
19	32152-1	Locknut	4
20	325-5	Capscrew	4
*		Air Cleaner Kit	1
*†	650152	Screw	2
*†	31752	Decal	1
*†	31692	Body	1
*†	30727	Element	1
*†	28820	Screw w/Lockwasher	2
*†	31691	Bracket	1
*†	27277	Gasket	1

* Not Illustrated

† Obtain from your local Tecumseh Dealer

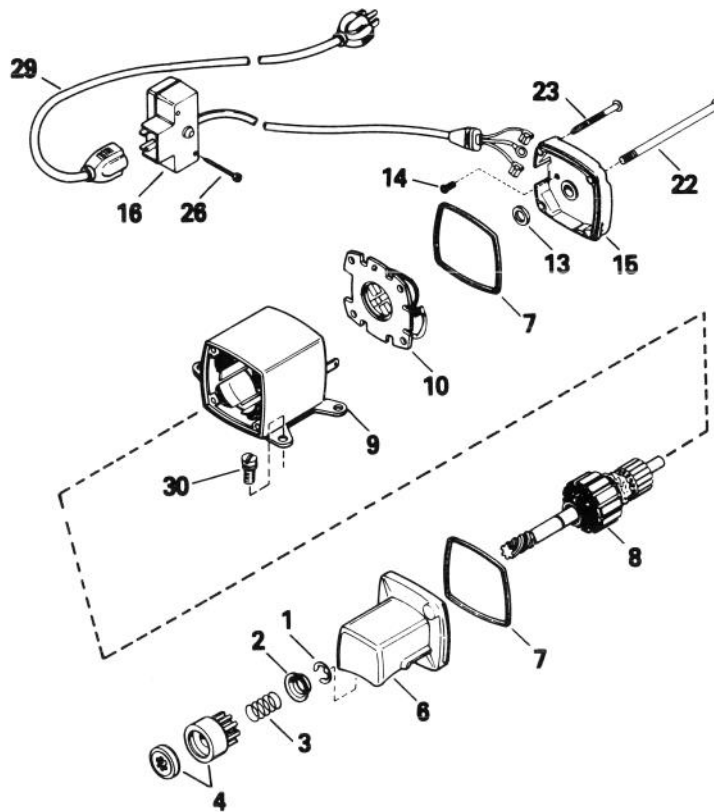

STARTER MOTOR KIT NO. 23-3790

Ref. No.	Part No.	Description	No. Used
1	31749	Ring — Retainer	1
2	33522	Retainer — Spring	1
3	33769	Spring — Anti-Drift	1
4	33524	Nut & Gear	1
6	35461	Cap Assy. — Drive End (Incl. Ref. #7)	1
7	35450	“O” Ring	2
8	35460	Armature	1
9	35459	Housing Assembly	1
10	35452	Card Assembly — Brush	1

Ref. No.	Part No.	Description	No. Used
13	590500	Washer — Thrust	1
14	33441	Screw — Ground	1
15	35453	Cap Assy. — Commutator End (Incl. Ref. #7)	1
16	35454	Box Assembly — Switch	1
22	35462	Bolt — Case	2
23	35456	Screw — Grounding	1
26	650819	Screw — Hex Hd. Self-Tap	2
29	32450A	Cord — Extension (10' 6")	1
30	650759	Screw — Hex Hd. Self-Tap	3

Note: Order individual parts from your local Tecumseh dealer.

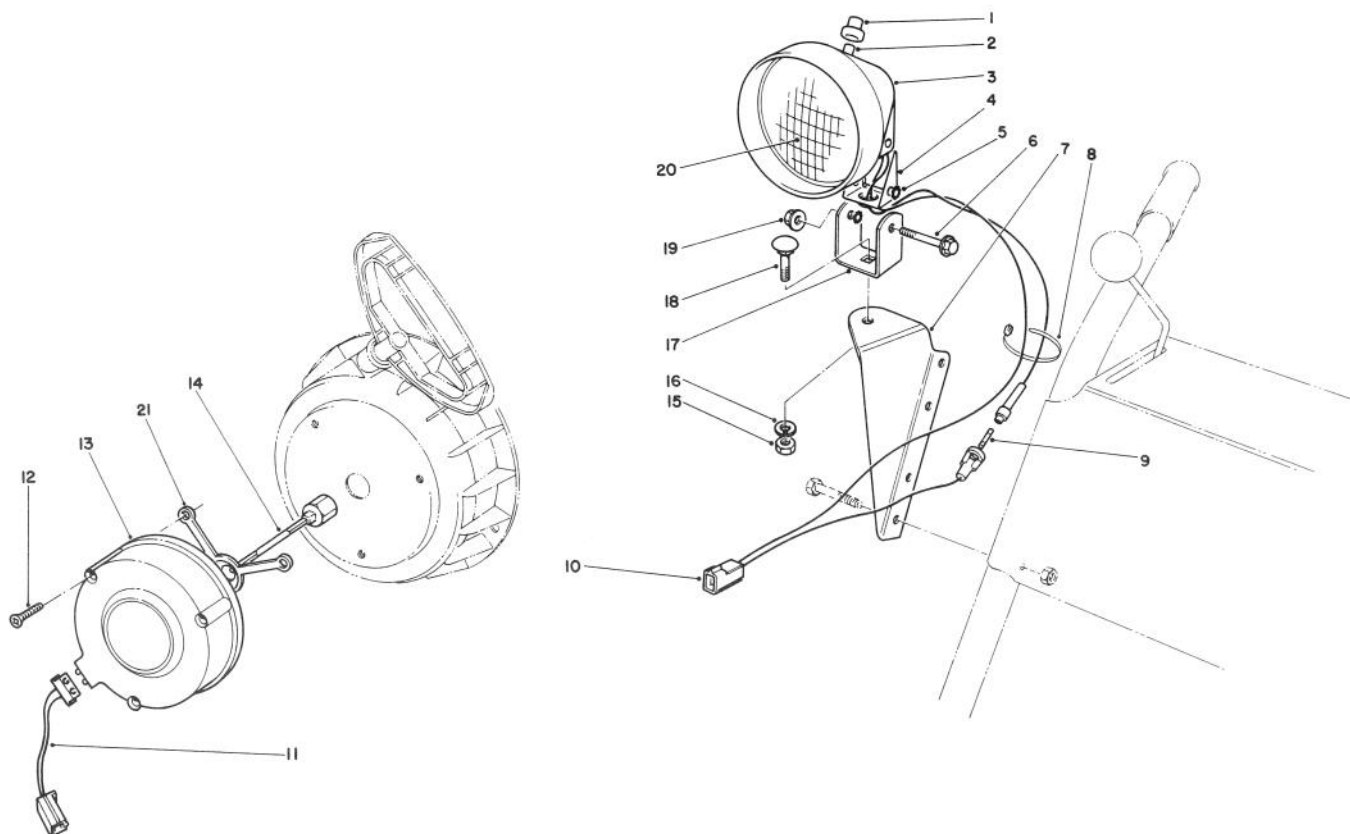

C-0037-89

LIGHT KIT NO. 54-9822 (Optional)

Ref. No.	Part No.	Description	No. Used
1	218-473	Boot — Switch	1
2	218-553	Switch Assembly	1
3	218-552	Bucket — Headlamp	1
4	218-554	Bracket	1
5	3255-8	Washer — Lock	2
6	322-13	Screw — Hex Flange Hd.	1
7	54-9830	Mount — Lamp	1
8	3290-378	Tie Wrap	2
9†		Fuse — 7-1/2 Amp.	1
10	218-555	Wire Assembly	1
11	2210-272	Connector — Light	1
12	2210-300	Screw — Self Tapping	3

Ref. No.	Part No.	Description	No. Used
13	2210-274	Alternator	1
14	2210-268	Shaft — Alternator 3"	1
15	3217-7	Nut — Hex	1
16	3253-21	Washer — Lock	1
17	218-556	Bracket — U	1
18	3231-2	Bolt — Carriage	1
19	32128-35	Nut — Flange Lock	1
20	218-16	Lens — Sealed Beam	1
*	54-9871	Headlamp Assembly Complete (Incl. Ref. #1-6, 9-10 & 15-21)	1
21	2210-299	Spacer	1

* Not Illustrated
† Obtain Locally

ENGINE TECUMSEH MODEL HS50-67259H

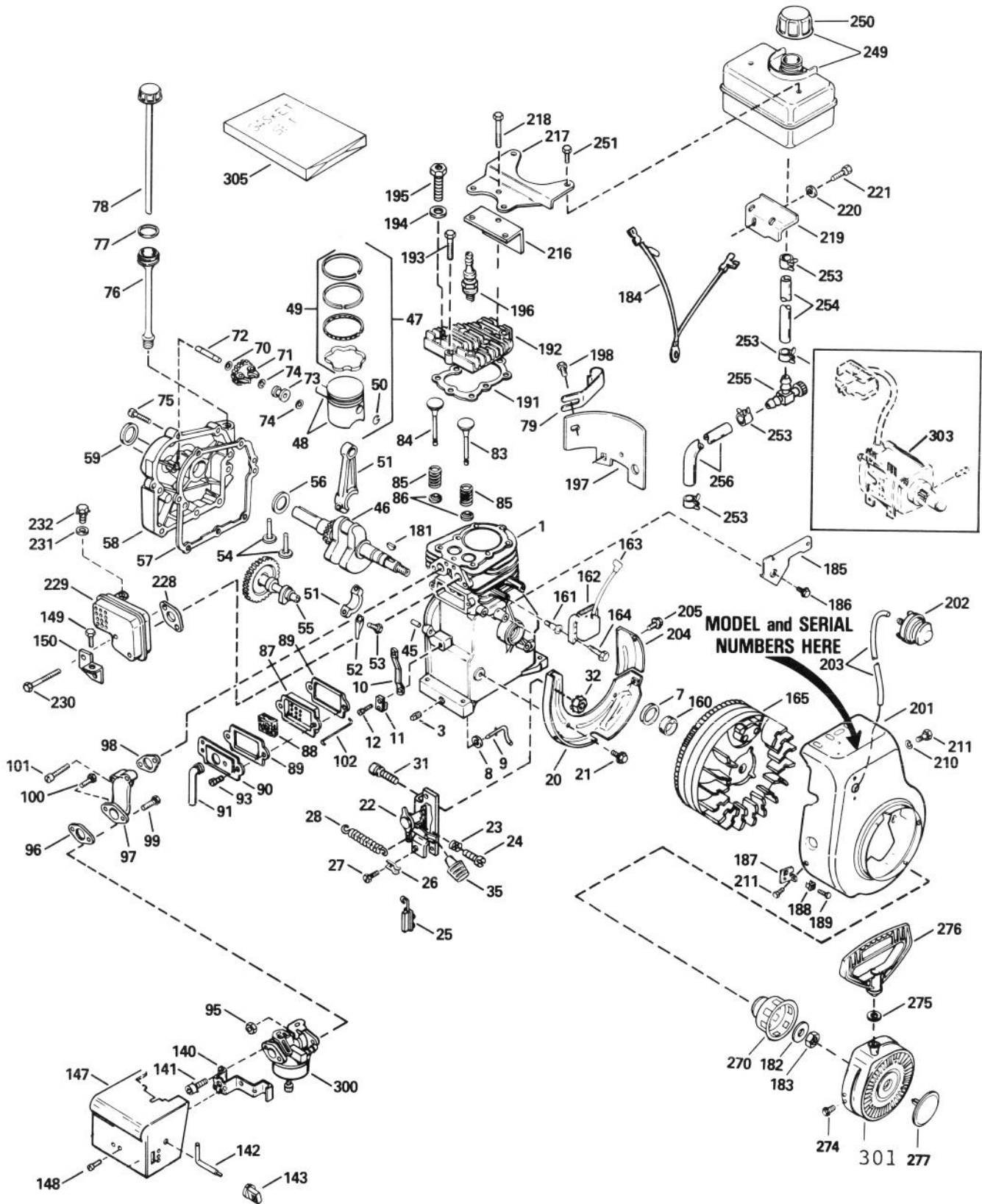

ENGINE TECUMSEH MODEL HS50-67259H

Ref. No.	Part No.	Description	No. Used	Ref. No.	Part No.	Description	No. Used
1	33674B	Cylinder Assembly (Incl. Ref. #3, 7 & 45)	1	58	34674A	Cover — Cylinder (Incl. Ref. #59 & 72)	1
3	27642	Plug — Pipe	2	59	27897	Seal — Oil	1
7	32600	Seal — Oil	1	70	30590A	Washer — Flat	1
8	28277	Washer — Flat	1	71	30591	Gear — Governor (Incl. Ref. #70)	1
9	31334	Rod — Governor	1	72	30574	Shaft — Mechanical Governor	1
10	31510	Lever — Governor	1	73	30588A	Spool — Governor	1
11	31335	Clamp — Governor Lever	1	74	29193	Ring — Retaining	2
12	650548	Screw — Hex Washer Hd.	1	75	650488	Screw — Hex Hd. Sems	7
20	†33342	Baffle — Blower Housing	1	76	35554	Tube Assy. — Oil Fill	1
21	650561	Screw — Hex Washer Hd. Durluk	2	77	35499	“O” Ring	1
22	†33858A	Control Assembly — Bracket (Incl. Ref. #23-27, 31 & 32)	1	78	35556	Dipstick	1
23	31342	Spring — Compression	1	79	35539	Clip — Oil Fill	1
24	650549	Screw — Fil. Hd.	1	83	29313C	Valve — Exhaust (Std.) (Incl. Ref. #86)	1
25	610973	Terminal Assembly	1	83	29315C	Valve — Exhaust (1/32” oversize) (Incl. Ref. #86)	1
26	27793	Clip — Conduit	1	84	32644A	Valve — Intake (Std.) (Incl. Ref. #86)	1
27	28942	Screw — Hex Washer Hd. Sems	1	84	32645A	Valve — Intake (1/32” oversize) (Incl. Ref. #86)	1
28	31426	Spring — Extension	1	85	31672	Spring — Valve	2
31	†650139	Screw — Fil. Hd. Sems	2	86	31673	Cap — Valve Spring	2
32	†30322	Nut — Lock	2	87	27666	Body — Valve Cover	1
35	35440	Knob — Speed Control	1	88	31410	Element — Valve Body	1
45	26727	Pin — Dowel	2	89	*27234	Gasket — Valve Cover	1
46	34740	Crankshaft Assembly	1	90	34146	Cover — Breather	1
47	34535	Piston — Pin & Ring Assy. (Std.) (Incl. Ref. #48, 49 & 50)	1	91	35350	Tube — Breather	1
47	34536	Piston — Pin & Ring Assembly (.010 oversize) (Incl. Ref. #48, 49 & 50)	1	93	650128	Screw — Fil. Hd. Sems	2
47	34537	Piston — Pin & Ring Assembly (.020 oversize) (Incl. Ref. #48, 49 & 50)	1	95	29752	Nut & Lockwasher Assy.	2
48	33562B	Piston & Pin Assy. (Std.) (Incl. Ref. #50)	1	96	*26756	Gasket — Carburetor	1
48	33563B	Piston & Pin Assembly (.010 oversize) (Incl. Ref. #50)	1	97	33691	Pipe — Intake	1
48	33564B	Piston & Pin Assembly (.020 oversize) (Incl. Ref. #50)	1	98	*33673	Gasket — Intake	1
49	33567	Ring Set — Piston (Std.)	1	99	6201	Screw — Hex Hd.	1
49	33568	Ring Set — Piston (.010 oversize)	1	100	650870	Screw — Hex Hd.	1
49	33569	Ring Set — Piston (.020 oversize)	1	101	650664	Screw — Fil. Hd. Sems	2
50	20381	Ring — Piston Pin Retaining	2	102	32698	Link — Governor to Throttle	1
51	32875	Rod Assy. — Connecting (Incl. Ref. #52 & 53)	1	140	34583	Bracket — Choke	1
52	32654	Dipper — Oil	1	141	28820	Screw — Fil. Hd. Sems	2
53	32610A	Bolt — Connecting Rod	2	142	34582	Rod — Choke	1
54	27241	Lifter — Valve	2	143	35438	Knob — Choke Control	1
55	33158	Camshaft (Compression Release)	1	147	35072	Cover — Carburetor	1
56	32323	Washer — Thrust	1	148	650257	Screw — Pan Hd. Sems	2
57	*27677	Gasket — Cylinder Cover	1	149	650735	Screw — Hex Hd. Sems Taptite	1
				150	33333	Bracket — Carburetor Cover	1
				160	34080	Spacer — Flywheel Key	1
				161	650872	Stud — Solid State Mounting	2
				162	34443A	Solid State Assembly	1
				163	610118	Cover — Spark Plug	1
				164	650814	Screw — Hex Hd. Sems	2
				165	611081	Flywheel (w/Ring Gear)	1
				181	610961	Key — Flywheel	1

* Indicates Parts Included in Gasket Set, Ref. #305.

† In original production the speed control assembly is riveted to the blower housing baffle. Replacement speed control assembly includes screws and nuts for mounting. Replacement baffle has threaded holes.

ENGINE TECUMSEH MODEL HS50-67259H (Continued)

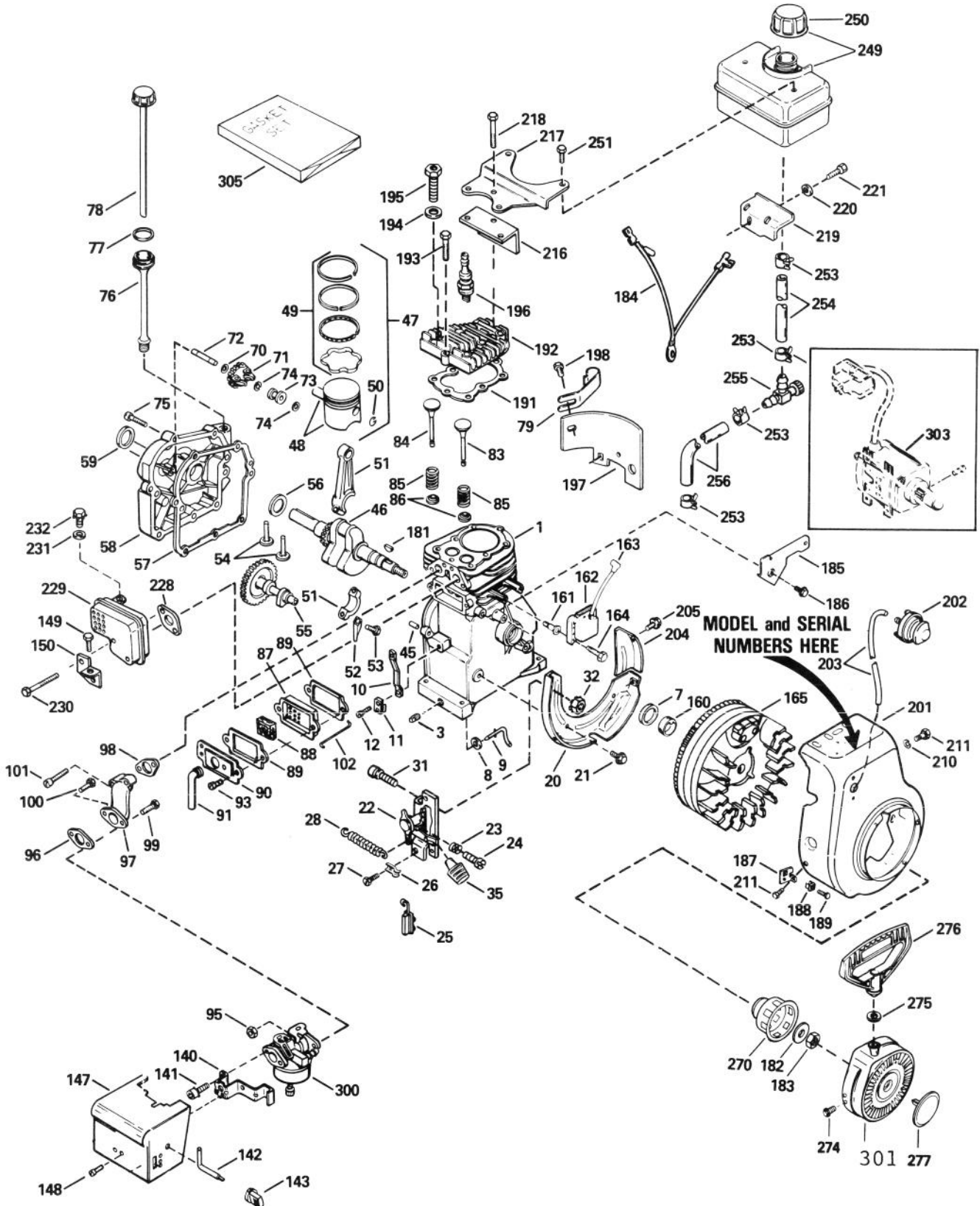

ENGINE TECUMSEH MODEL HS50-67259H (Continued)

Ref. No.	Part No.	Description	No. Used
182	650815	Washer — Belleville	1
183	650863	Nut — Flywheel	1
184	35557	Wire — Ground	1
185	34212	Bracket — Hold Down	1
186	30200	Screw — Hex Washer Hd. Self-Tap. Sems	1
187	34126	Bracket — Grommet Mounting	1
188	28545	Grommet — Plastic	1
189	650760	Screw — Pan Hd. Taptite	1
191	*33554	Gasket — Cylinder Head	1
192	33016A	Head — Cylinder (Incl. Ref. #218)	1
193	6021A	Screw — Hex Flange Hd.	3
194	650691	Washer — Flat	1
195	650818	Screw — Special Hex. Hd.	1
196	35395	Plug — Spark (Champion RJ-19LM or equivalent)	1
197	29745	Extension — Blower Housing	1
198	650128	Screw — Fil. Hd. Sems	1
201	35656	Housing — Blower	1
202	570682	Primer Assembly	1
203	32180C	Line — Primer	1
204	33341	Extension — Baffle	1
205	650701	Screw — Hex Washer Hd. Shakeproof Self-Drilling	1
210	650168	Washer — Flat	1
211	29212	Screw — Hex Hd. Sems	2
216	33344	Baffle — Heat	1
217	28371B	Plate — Fuel Tank	1
218	650694A	Screw — Hex Flange Hd.	5

Ref. No.	Part No.	Description	No. Used
219	34182	Bracket — Fuel Tank Mounting	1
220	650675	Washer — Flat	1
221	650805	Screw — Hex Hd. w/Belleville Washer	1
228	*33670	Gasket — Exhaust	1
229	33697A	Muffler	1
230	650327	Screw — Fil. Hd. Sems	2
231	8345	Washer — Flat	1
232	30063	Screw — Hex Washer Hd. Sems	1
249	35584	Tank Assembly — Fuel (Incl. Ref. #250 & 253)	1
250	35355	Cap — Fuel Tank	1
251	650665	Screw — Hex Washer Hd. Self-Tap Sems	2
253	26460	Clamp — Fuel Line	4
254	29774	Line — Fuel	1
255	32961	Valve — Shut-Off	1
256	30705	Line — Fuel	1
270	34694	Cup — Starter	1
274	650884	Screw — Hex Washer Hd.	1
275	650168	Washer — Flat	1
276	590574	Handle — Starter	1
277	35392	Plug — Starter	1
300	632107	Carburetor (Incl. Ref. #96)	1
301	590646	Starter — Rewind	1
303		Electric Starter Kit 33290C (Optional) Sold as Accessory	1
305	33683A	Gasket Set (Incl. Items Marked *)	1

* Indicates Parts Included in Gasket Set, Ref. #305.

† In original production the speed control assembly is riveted to the blower housing baffle. Replacement speed control assembly includes screws and nuts for mounting. Replacement baffle has threaded holes.

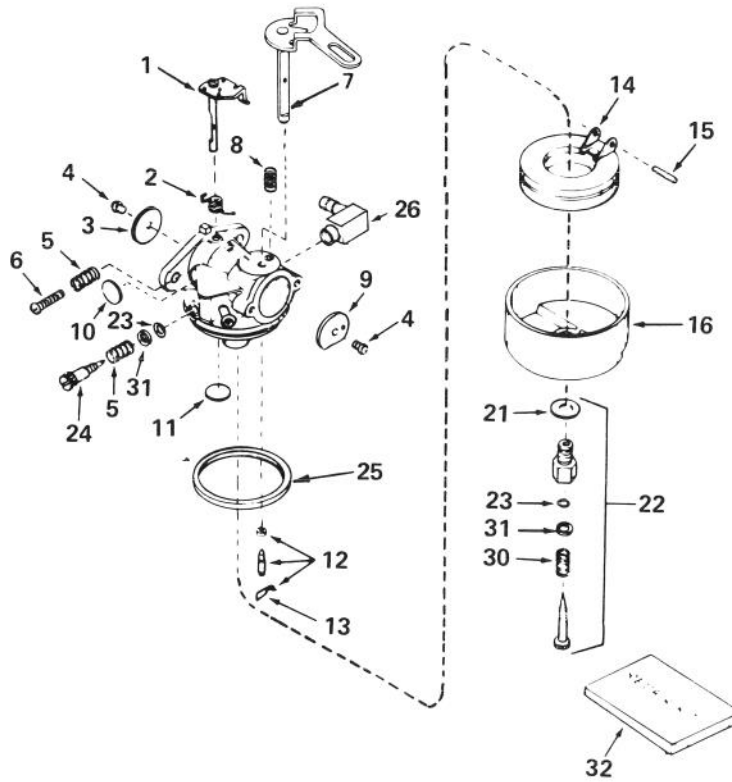

CARBURETOR NO. 632107

Ref. No.	Part No.	Description	No. Used
	632107	Carburetor	1
1	631615	Shaft & Lever Assy. — Throttle	1
2	631767	Spring — Throttle Return	1
3	631036	Shutter — Throttle	1
4	650506	Screw	2
5	630766	Spring — Idle Regulating Screw	1
6	650417	Screw — Idle Regulating	1
7	632108	Shaft & Lever Assy. — Choke	1
8	630735	Spring — Choke Stop	1
9	631815	Shutter — Choke	1
10*	630748	Plug — Welch	1
11*	631027	Plug — Welch	1
12*	631021	Inlet Needle — Seat & Clip Assy. (Incl. Ref. #13)	1
13	631022	Clip — Inlet Needle	1

Ref. No.	Part No.	Description	No. Used
14	632019	Float — Carburetor	1
15*	631024	Shaft — Float	1
16	631867	Bowl — Float	1
21	27110	Gasket — Bowl-to-Body	1
22*	31839	Adjustment Screw Assy. — Main (Incl. Ref. #21, 23, 30 & 31)	1
23*	630740	“O” Ring — Adjustment Screw	1
24*	631078	Screw — Idle Adjustment	1
25*	631028	Gasket — Bowl-to-Body	1
26	631807	Fitting — Fuel Inlet	1
30	630738	Spring — Main Adjustment Screw	1
31	630739	Washer — Flat	1
32	31840	Repair Kit (Incl. Items Marked *)	1

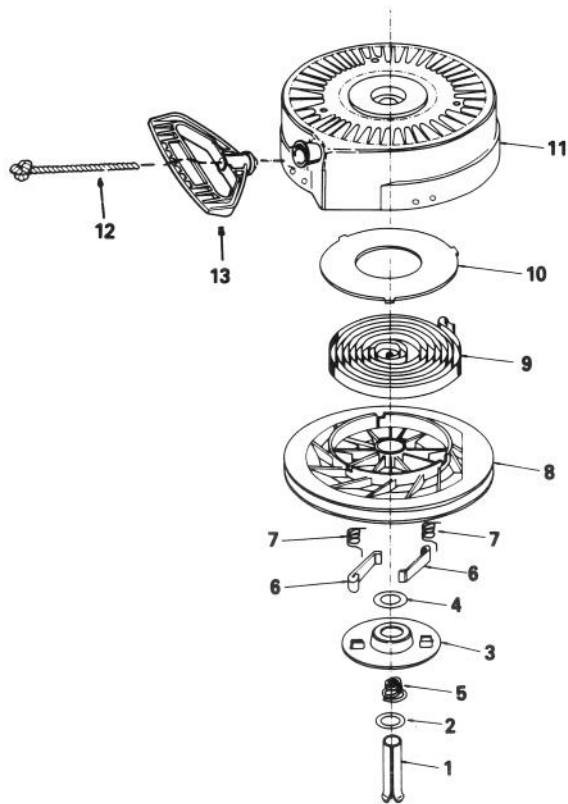

REWIND STARTER NO. 590646

Ref. No.	Part No.	Description	No. Used
	590646	Starter — Rewind	1
1	590599A	Pin — Spring (Incl. Ref. #4)	1
2	590600	Washer	1
3	590615	Retainer	1
4	590601	Washer	1
5	590598	Spring — Brake	1
6	590616	Dog — Starter	1
7	590617	Spring — Dog	1

Ref. No.	Part No.	Description	No. Used
8	590645	Pulley	1
9	590619	Spring — Rewind	1
10	590620	Cover — Spring	1
11	590647	Housing Assy. — Starter	1
12	590451A	Rope — Starter (Length 69" & 5/32" dia.)	1
13	590574	Handle — Mitten Grip (Not included with Starter)	1

PRODUCT CHANGES

In an effort to make improvements available to TORO owners as quickly as possible, minor changes are incorporated into Toro's products from time to time that do not become immediately shown in the Parts Catalog. If such a change apparently has been made in your unit, which is not reflected in your manual, see your TORO Distributor or his Authorized TORO Service Dealer for information and part numbers.

IDENTIFICATION AND ORDERING

MODEL AND SERIAL NUMBERS

The Snowthrower has two identification numbers: a model number and a serial number. The two numbers are stamped on a decal which is located on back of the engine mounting plate. In any correspondence concerning the Snowthrower, supply model and serial numbers to assure that correct information and replacement parts are obtained.

To order replacement parts from an Authorized TORO Service Dealer, supply the following information:

1. Model and serial numbers of the Snowthrower.
2. Part number, description, and quantity of part(s) desired.

Note: Do not order by reference number if a parts catalog is being used; use the PART NUMBER.

The Toro Promise

A TWO YEAR LIMITED WARRANTY On All Gasoline Powered Consumer Products

The Toro Company promises to repair your TORO Product if defective in materials or workmanship. The following time periods from the date of purchase apply:

Residential Product 2 Years
Residential Products Used Commercially 45 Days

The costs of parts and labor are included, but the customer pays the transportation costs. Just return any residential product to an Authorized TORO Service Dealer or TORO Distributor.

Should you feel your TORO Product is defective and wish to rely on The Toro Promise, the following procedure is recommended:

1. Contact any Authorized TORO Service Dealer, TORO Master Service Dealer, or TORO Distributor (the Yellow Pages of your telephone directory is a good reference source).
2. He will either instruct you to return the product to him or recommend another Authorized TORO Service outlet which might be more convenient.
3. Bring the product along with your original sales slip, or other evidence of purchase date, to the service dealer.
4. The servicing dealer will inspect the unit, advise you whether the product is defective and, if so, make all repairs necessary to correct the defect without extra charge to you.

If for any reason you are dissatisfied with the dealer's analysis of the defect or the service performed, you may contact us.

Write:

TORO Consumer Service Department
8111 Lyndale Avenue South
Minneapolis, Minnesota 55420

The above remedy of product defects through repair by an Authorized TORO Service Dealer is the purchaser's sole remedy for any defect.

THERE IS NO OTHER EXPRESS WARRANTY. ALL IMPLIED WARRANTIES OF MERCHANTABILITY AND

FITNESS FOR USE ARE LIMITED TO THE DURATION OF THE EXPRESS WARRANTY.

Some states do not allow limitations on how long an implied warranty lasts, so the above limitation may not apply to you.

This warranty applies only to parts or components which are defective and does not cover repairs necessary due to normal wear, misuse, accidents, or lack of proper maintenance. Regular, routine maintenance of the unit to keep it in proper operating condition is the responsibility of the owner.

All warranty repairs reimbursable under The Toro Promise must be performed by an Authorized TORO Service Dealer using Toro approved replacement parts.

Repairs or attempted repairs by anyone other than an Authorized TORO Service Account are not reimbursable under The Toro Promise. In addition, these unauthorized repair attempts may result in additional malfunctions, the correction of which is not covered by warranty.

THE TORO COMPANY IS NOT LIABLE FOR INDIRECT, INCIDENTAL OR CONSEQUENTIAL DAMAGES IN CONNECTION WITH THE USE OF THE PRODUCT INCLUDING ANY COST OR EXPENSE OF PROVIDING SUBSTITUTE EQUIPMENT OR SERVICE DURING PERIODS OF MALFUNCTION OR NON-USE.

Some states do not allow the exclusion or limitation of incidental or consequential damages, so the above limitation or exclusion may not apply to you.

This warranty gives you specific legal rights, and you may also have other rights which vary from state to state.

COUNTRIES OTHER THAN THE UNITED STATES OR CANADA

Customers who have purchased TORO products exported from the United States or Canada should contact their TORO Distributor (Dealer) to obtain guarantee policies for your country, province or state. If for any reason

you are dissatisfied with your Distributor's service or have difficulty obtaining guarantee information, contact the TORO importer. If all other remedies fail, you may contact us at The Toro Company.