



ProCore 648 Aerator

Model No. 09200-260000001 & Up

Operator's Manual



English (EN, GB)



Warning



CALIFORNIA

Proposition 65 Warning

The engine exhaust from this product contains chemicals known to the State of California to cause cancer, birth defects, or other reproductive harm.

Important This engine is not equipped with a spark arrester muffler. It is a violation of California Public Resource Code Section 4442 to use or operate this engine on any forest-covered, brush-covered or grass-covered land. Other states or federal areas may have similar laws.

This spark ignition system complies with Canadian ICES-002.

Ce système d'allumage par étincelle de véhicule est conforme à la norme NMB-002 du Canada.

Contents

	Page
Introduction	3
Safety	3
Safe Operating Practices	3
Sound Pressure Level	5
Sound Power Level	5
Vibration Level	5
Safety and Instruction Decals	5
Specifications	9
Accessory Chart	10
Setup	11
Loose Parts Chart	11
Install the Rear Wheels	12
Install the Handle	12
Activate, Charge and Connect the Battery	12
Secure Rear Hood	14
Secure Belt Cover	14
Install Tine Holders, Turf Guards and Tines	14
Before Operating	15
Recommended Gasoline	15
Using Stabilizer/Conditioner	15
Filling the Fuel Tank	16
Check Engine Oil Level	16
Check Hydraulic System Fluid	17
Check the Tire Pressure	18

	Page
Operation	19
Controls	19
Starting and Stopping the Engine	20
The Safety Interlock System	21
Service Latches	21
Install Tine Holders, Turf Guards and Tines	22
Setting the Coring Depth	23
Manual Ground Following	23
Pushing/Pulling the Aerator by Hand	24
System Control Circuit Reset	24
Coring Head Stranded In Lowered Position	24
Transporting Aerator	25
Loading Aerator	26
Operating Tips	26
Using Line Marker	27
Adjusting Weight Transfer	28
Additional Weight	28
Aerator Control Module (ACM)	29
Maintenance	30
Recommended Maintenance Schedule	30
Daily Maintenance Checklist	31
Lubrication	32
Jacking Instructions	32
Servicing the Air Cleaner	33
Servicing the Engine Oil	34
Servicing the Spark Plug	35
Servicing the Fuel Filter	36
Servicing the Fuel Tank	37
Cleaning the Cooling Systems	37
Servicing the Hydraulic System	37
Re-setting Ground Following System	39
Inspecting Belts	39
Side Shield Adjustment	40
Adjusting Pump Belt	40
Replacing the Turf Guards	41
Adjusting Hole Spacing	41
Check Torque of Coring Head Fasteners	42
Coring Head Timing	42
Servicing the Fuses	42
Servicing the Battery	42
Storing the Battery	43
Troubleshooting	44
Wiring Schematic	46
Hydraulic Schematic	47
Cleaning and Storage	48
Evaporative Emission Control Warranty Statement ..	51
The Toro Aerator Commercial Products Warranty ..	52

Introduction

Read this manual carefully to learn how to operate and maintain your product properly. The information in this manual can help you and others avoid injury and product damage. Although Toro designs and produces safe products, you are responsible for operating the product properly and safely.

Whenever you need service, genuine Toro parts, or additional information, contact an Authorized Service Distributor or Toro Customer Service and have the model and serial numbers of your product ready. Figure 1 illustrates the location of the model and serial numbers on the product.

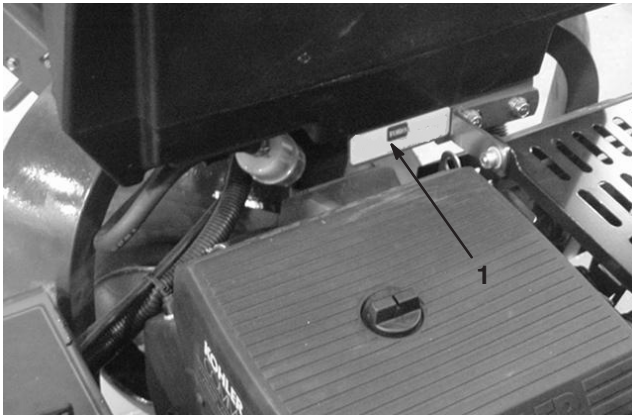

Figure 1

1. Location of the model and serial numbers

Write the product model and serial numbers in the space below:

Model No. _____
Serial No. _____

This manual identifies potential hazards and has special safety messages that help you and others avoid personal injury and even death. **Danger**, **Warning**, and **Caution** are signal words used to identify the level of hazard. However, regardless of the hazard, be extremely careful.

Danger signals an extreme hazard that *will* cause serious injury or death if you do not follow the recommended precautions.

Warning signals a hazard that *may* cause serious injury or death if you do not follow the recommended precautions.

Caution signals a hazard that may cause minor or moderate injury if you do not follow the recommended precautions.

This manual uses two other words to highlight information. **Important** calls attention to special mechanical information and **Note** emphasizes general information worthy of special attention.

Safety

Improper use or maintenance by the operator or owner can result in injury. To reduce the potential for injury, comply with these safety instructions and always pay attention to the safety alert symbol, which means CAUTION, WARNING, or DANGER—“personal safety instruction.” Failure to comply with the instruction may result in personal injury or death.

Safe Operating Practices

The following instructions are from ANSI standard B71.4—1999.

Training

- Read the Operator’s Manual and other training material. If the operator(s) or mechanic(s) can not read English it is the owner’s responsibility to explain this material to them.
- Become familiar with the safe operation of the equipment, operator controls, and safety signs.
- All operators and mechanics should be trained. The owner is responsible for training the users.
- Never let children or untrained people operate or service the equipment. Local regulations may restrict the age of the operator.
- The owner/user can prevent and is responsible for accidents or injuries occurring to himself or herself, other people or property.

Preparation

- Evaluate the terrain to determine what accessories and attachments are needed to properly and safely perform the job. Only use accessories and attachments approved by the manufacturer.
- Wear appropriate clothing including hard hat, safety glasses and hearing protection. Long hair, loose clothing or jewelry may get tangled in moving parts.
- Inspect the area where the equipment is to be used and remove all objects such as rocks, toys and wire which can be contacted by the aerator.
- Use extra care when handling gasoline and other fuels. They are flammable and vapors are explosive.
 - Use only an approved container

- Never remove gas cap or add fuel with engine running. Allow engine to cool before refueling. Do not smoke.
- Never refuel or drain the aerator indoors.
- Check that operator's presence controls, safety switches and shields are attached and functioning properly. Do not operate unless they are functioning properly.

Operation

- Never run an engine in an enclosed area.
- Only operate in good light, keeping away from holes and hidden hazards.
- Be sure all drives are in neutral and parking brake is engaged before starting engine. Start the engine only from the operator's position.
- Never operate without the shields, covers or other guards securely in place. Be sure all interlocks are functioning properly.
- Do not change the engine governor setting or overspeed the engine.
- Stop on level ground, raise coring head, disengage drives, engage parking brake, shut off engine before leaving the operator's position for any reason.
- Stop equipment and inspect tines after striking objects or if an abnormal vibration occurs. Make necessary repairs before resuming operations.
- Keep hands and feet away from the tine area.
- Never carry passengers and keep pets and bystanders away.
- Be alert, slow down and use caution when making turns. Look behind and to the side before changing directions.
- Slow down and use caution when crossing roads and sidewalks.
- Do not operate the aerator under the influence of alcohol or drugs.
- Use extreme care when loading or unloading the aerator into a trailer or truck.
- Use care when approaching blind corners, shrubs, trees, or other objects that may obscure vision.

Slope Operation

- Do not operate near drop-offs, ditches, steep banks or water. Wheels dropping over edges can cause rollovers, which may result in serious injury or death.

- Do not operate on slopes when grass is wet. Slippery conditions reduce traction and could cause sliding and loss of control.
- Do not make sudden turns or rapid speed changes.
- Reduce speed and use extreme caution on slopes.
- Remove or mark obstacles such as rocks, tree limbs, etc. from the operating area. Tall grass can hide obstacles.
- Watch for ditches, holes, rocks, dips, and rises that change the operating angle, as rough terrain could overturn the aerator.
- Be aware that loss of traction may occur going downhill. Weight transfer to the front wheel may cause drive wheels to slip and cause loss of braking and steering.
- Always avoid sudden starting or stopping on a slope. If tires lose traction, disengage the tines and proceed slowly off the slope.
- Follow the manufacturer's recommendations for wheel weights or counterweights to improve stability.

Maintenance and storage

- Wait for all movement to stop before adjusting, cleaning or repairing. Disengage tines, raise coring head, set parking brake, stop engine and remove key.
- Clean grass and debris from tines, drives, mufflers, and engine to help prevent fires. Clean up oil or fuel spillage.
- Let engine cool before storing and do not store near flame.
- Shut off fuel while storing or transporting on trailers. Do not store fuel near flames or drain indoors.
- Park aerator on level, hard ground. Never allow untrained personnel to service aerator.
- Use jack stands or safety latches to support components when required.
- Carefully release pressure from components with stored energy.
- Disconnect battery or remove spark plug wire before making any repairs. Disconnect the negative terminal first and the positive last. Reconnect positive first and negative last.
- Keep hands and feet away from moving parts. If possible, do not make adjustments with the engine running.
- Charge batteries in an open well ventilated area, away from spark and flames. Unplug charger before connecting or disconnecting from battery. Wear protective clothing and use insulated tools.

- Keep all parts in good working condition and all hardware tightened. Replace all worn or damaged decals.
- Use only Toro-approved attachments. Warranty may be voided if used with unapproved attachments.

Sound Pressure Level

This unit has an equivalent continuous A-weighted sound pressure level at the operator ear of 84 dBA, based on measurements of identical machines per Directive 98/37/EC and amendments.

Sound Power Level

This unit has a guaranteed sound power level of: 102 dBA/1 pW, based on measurements of identical machines per Directive 2000/14/EC and amendments.

Vibration Level

This unit does not exceed a vibration level of 2.5 m/s² at the hands based on measurements of identical machines per ISO 5349 procedures.

This unit does not exceed a vibration level of .5 m/s² at the posterior based on measurements of identical machines per ISO 2631 procedures.

Safety and Instruction Decals



Safety decals and instructions are easily visible to the operator and are located near any area of potential danger. Replace any decal that is damaged or lost.

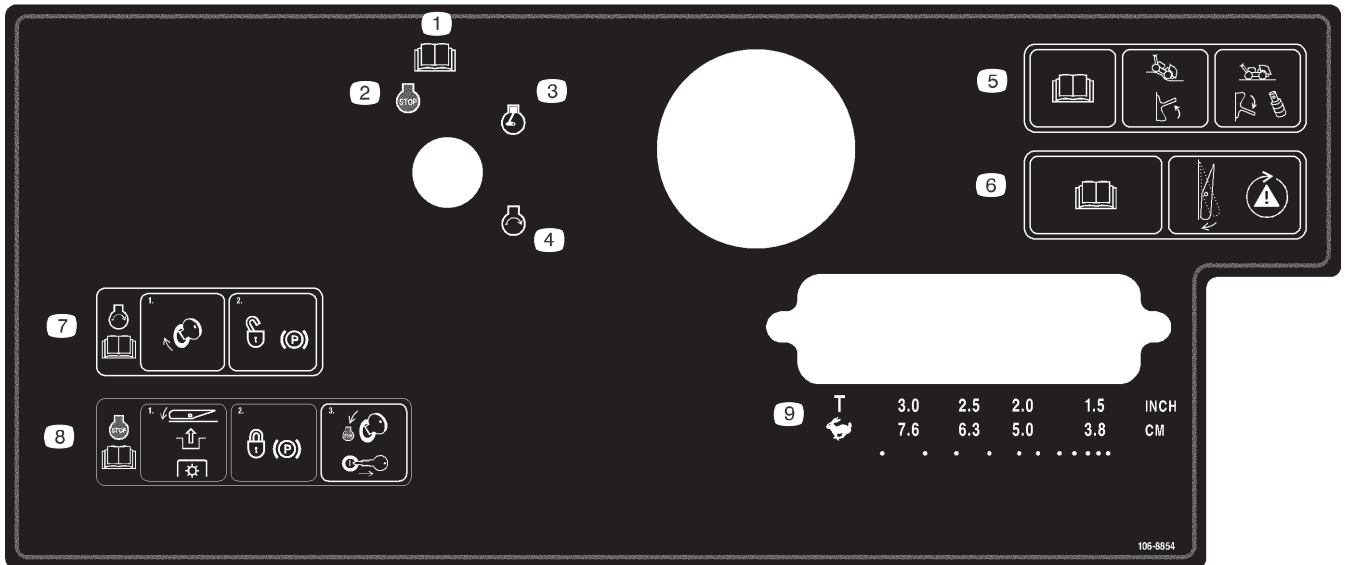

106-8854

1. Read the *Operator's Manual*.
2. Engine—stop
3. Engine—run
4. Engine—start
5. Read the *Operator's Manual*; move the switch up to turn ground following on; move the switch down and install the spacers to turn ground following off.
6. Read the *Operator's Manual*; press the switch to test the safety system.
7. To start the engine, turn the ignition key and unlock the parking brake; read the *Operator's Manual*.
8. To stop the engine, press the switch to disengage the PTO, lock the parking brake, and turn the ignition key to the Stop position and remove it; read the *Operator's Manual*.
9. Transport or hole spacing selection

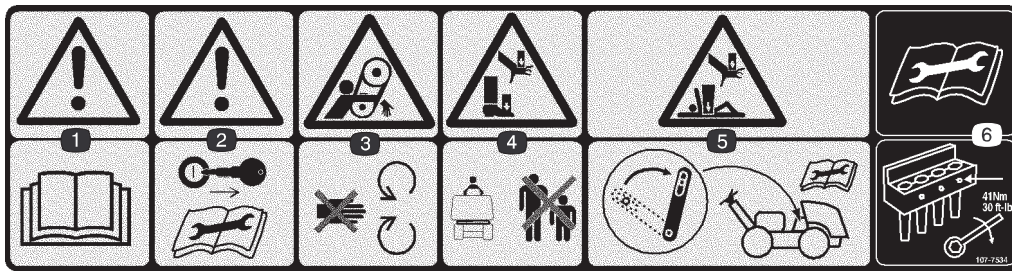

107-7534

1. Warning—read the *Operator's Manual*.
2. Warning—remove the ignition key and read the instructions before servicing or performing maintenance.
3. Entanglement hazard, belt—stay away from moving parts.
4. Crushing hazard of hand or foot—keep bystanders a safe distance from the machine.
5. Crushing hazard of hand and body—engage the service latch when the coring head is raised; read the instructions before servicing or performing maintenance.
6. Read the instructions before servicing or performing maintenance—torque the tine bolts to 41 N·m (30 ft.-lb).

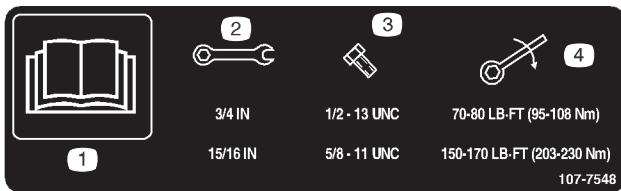

107-7548

1. Read the *Operator's Manual*.
2. Wrench size
3. Bolt size
4. Torque



93-9363

1. Parking brake
2. Locked
3. Unlocked

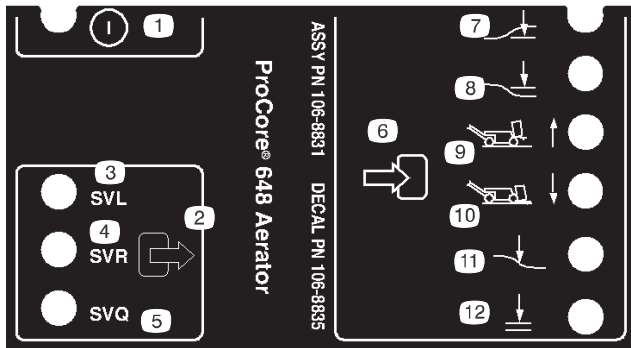

106-8835

1. On/off
2. Output
3. Solenoid valve lower
4. Solenoid valve raise
5. Solenoid valve quick
6. Input
7. Head low
8. Head high
9. Transport (#1)
10. Aerate (#4)
11. Ground following
12. OK to lower



Battery Symbols

Some or all of these symbols are on your battery.

1. Explosion hazard
2. No fire, open flames, or smoking.
3. Caustic liquid/chemical burn hazard
4. Wear eye protection
5. Read the *Operator's Manual*.
6. Keep bystanders a safe distance from the battery.
7. Wear eye protection; explosive gases can cause blindness and other injuries
8. Battery acid can cause blindness or severe burns.
9. Flush eyes immediately with water and get medical help fast.
10. Contains lead; do not discard.

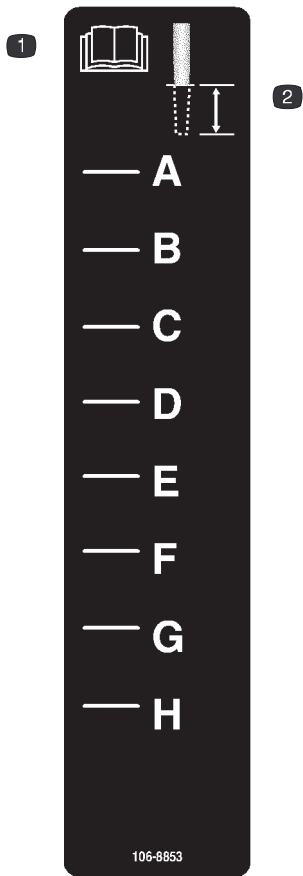

106-8853

1. Read the *Operator's Manual*.
2. Coring depth

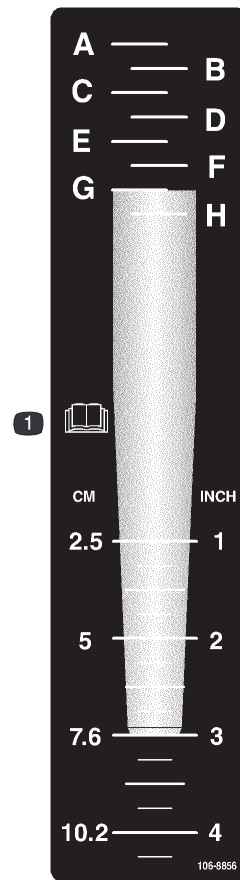

106-8856

1. Read the *Operator's Manual*.



93-9084

1. Lift point
2. Tie-down point



93-6696

1. Stored energy hazard—read the *Operator's Manual*.



107-7555

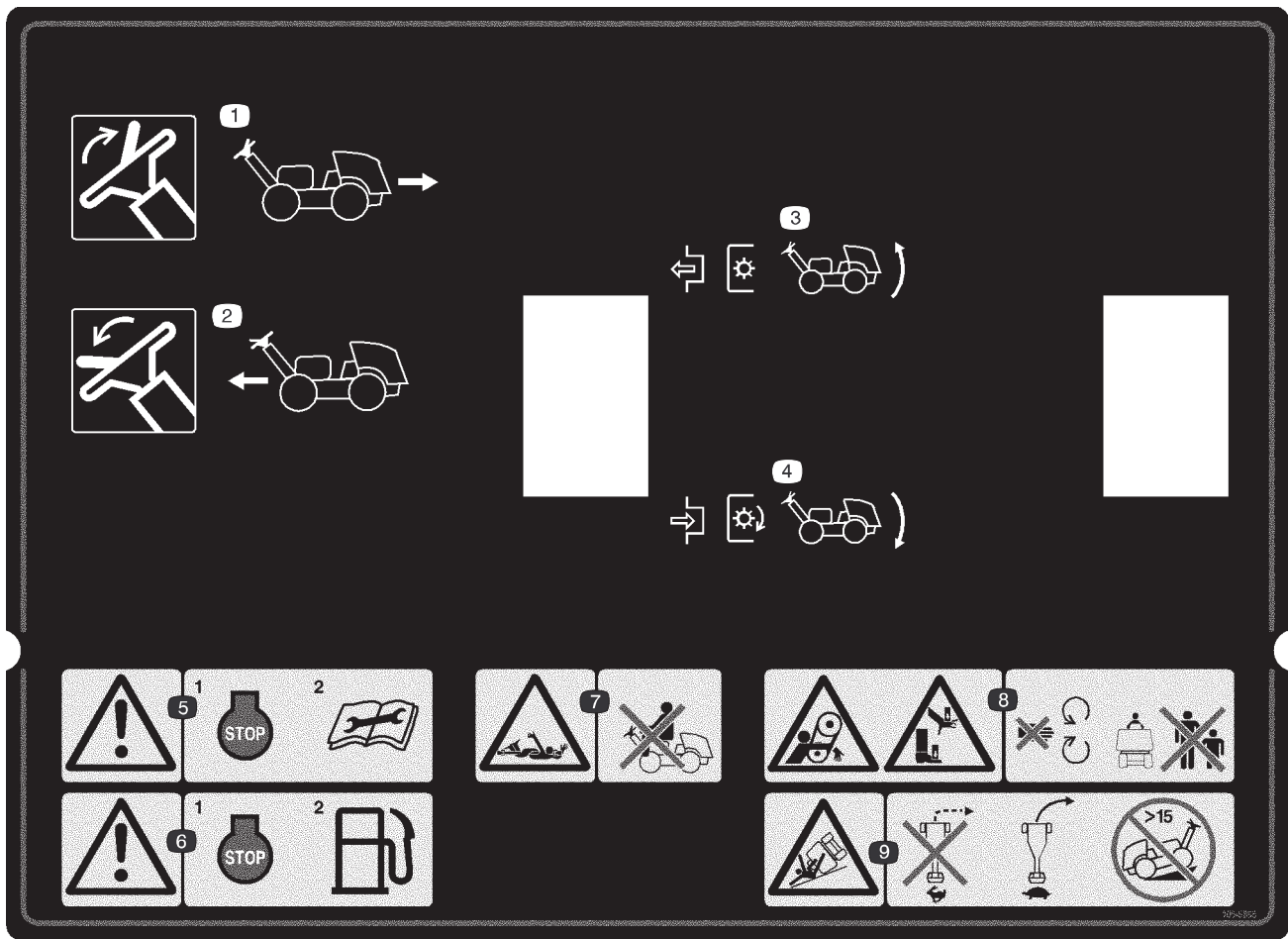

106-8855

1. Move the lever up to drive in reverse.
2. Move the lever down to drive forward.
3. Disengage the PTO and raise the head.
4. Engage the PTO and lower the head.
5. Warning—stop the engine and read the instructions before servicing or performing maintenance.
6. Warning—stop the engine before fueling.
7. Entanglement hazard, shaft—do not carry passengers.
8. Entanglement hazard, belt and Crushing hazard of hand or foot—stay away from moving parts and keep bystanders a safe distance from the machine.
9. Tipping hazard—do not turn sharply while traveling fast, drive slowly when turning, and do not drive the machine on a slope greater than 15 degrees.



107-7547

1. Entanglement hazard, belt—stay away from moving parts.
2. Warning—Do not touch the hot surfaces

Specifications

Engine	Kohler, 2 cylinder, air cooled, gasoline engine.19 HP (14.2 kW) @ 3000 rpm. Torque –32.5 lb–ft. @ 3000 rpm (44.1 N–m) 32.7 lb–ft max (44.3 N–m) @ 2400 rpm. High Idle–3400 rpm. Low Idle–1400 rpm. Displacement 41 cu–in. (674 cc). Air Filter–Dry, large capacity, replaceable element. Oil Filter–External, spin–on. Fan–High flow blower.
Tires	Front & Rear–20x10–10, 2 ply rated, smooth tread, tubeless, Inflated to 12 psi, demountable rims.
Controls	Ignition, throttle, choke, parking brake, traction lever, raise/lower, aeration spacing, manual/ground follow selector switch, system reset and aeration depth.
Electrical	Alternator/Generator–12 Volt, 15 Amp regulated charging Battery–BCI Group No.: U1, 300 Cold Cranking Amp @ 0° F Instrumentation–Hour/tachometer Controller–Micro–processor logic control Interlocks–Clutch Latch, traction neutral, coring head raise/lower
Capacities	Fuel 7.5 gal (28.4 L) Minimum (unleaded gasoline) Engine Oil w/ Filter 2 Qt. (1.9 L) (Mobil 10W–30) Hydraulic Oil 3.0 gal (11.3 L)
Brakes	Service Brake Dynamic through hydrostatic transmission Parking Brake Hand actuated on handle
Hydraulic System	Remote spin–on charge and return filters.
Drive Train	3 wheel drive, Parallel–Series hydrostatic, closed loop Pump Variable displacement piston type .97 cu–in (16 cc) full stroke 12 gpm (45.4 lpm) full stroke 2900 psi (200 bar) system relief Wheel Drive High torque, low speed wheel motors Rear 12 cu–in (197 cc) displacement Front 24 cu–in (393 cc) displacement
Speed & Direction	Hand controlled bail on handle Operator Presence–Coring head lifts and de–clutches if released Forward 0–3.5 mph (0–5.6 km/h), variable, 4 aeration speeds Reverse 0–2.0 mph (0–3.2 km/h), variable Aerating Detent 1 1.5” (3.8 cm) spacing Detent 2 2.0” (5.1 cm) spacing Detent 3 2.5” (6.4 cm) spacing Detent 4 3.0” (7.6 cm) spacing
Aerating Depth Control	True Core Micro–processor logic control of lift & lower via hydraulic solenoid/cylinder Fixed Mechanical stops, operator adjusted for desired depth
Dimensions	Overall Length 104.5 in. (265.4 cm) Overall Width 50.12 in. (127.3 cm) Height Head Raised 45.0 in. (114.3 cm) Head Lowered 36.5 in. (92.7 cm) Top of Handle 41.0 in. (104.1 cm) Wheel Base 44.5 in. (113.0 cm) Track Width 38.3 in. (97.3 cm) Coring Width 48 in. (122 cm) Ground Clearance 4.75 in. (12.1 cm) Weight (less fuel) 1590 lbs (721 Kg)

Accessory Chart

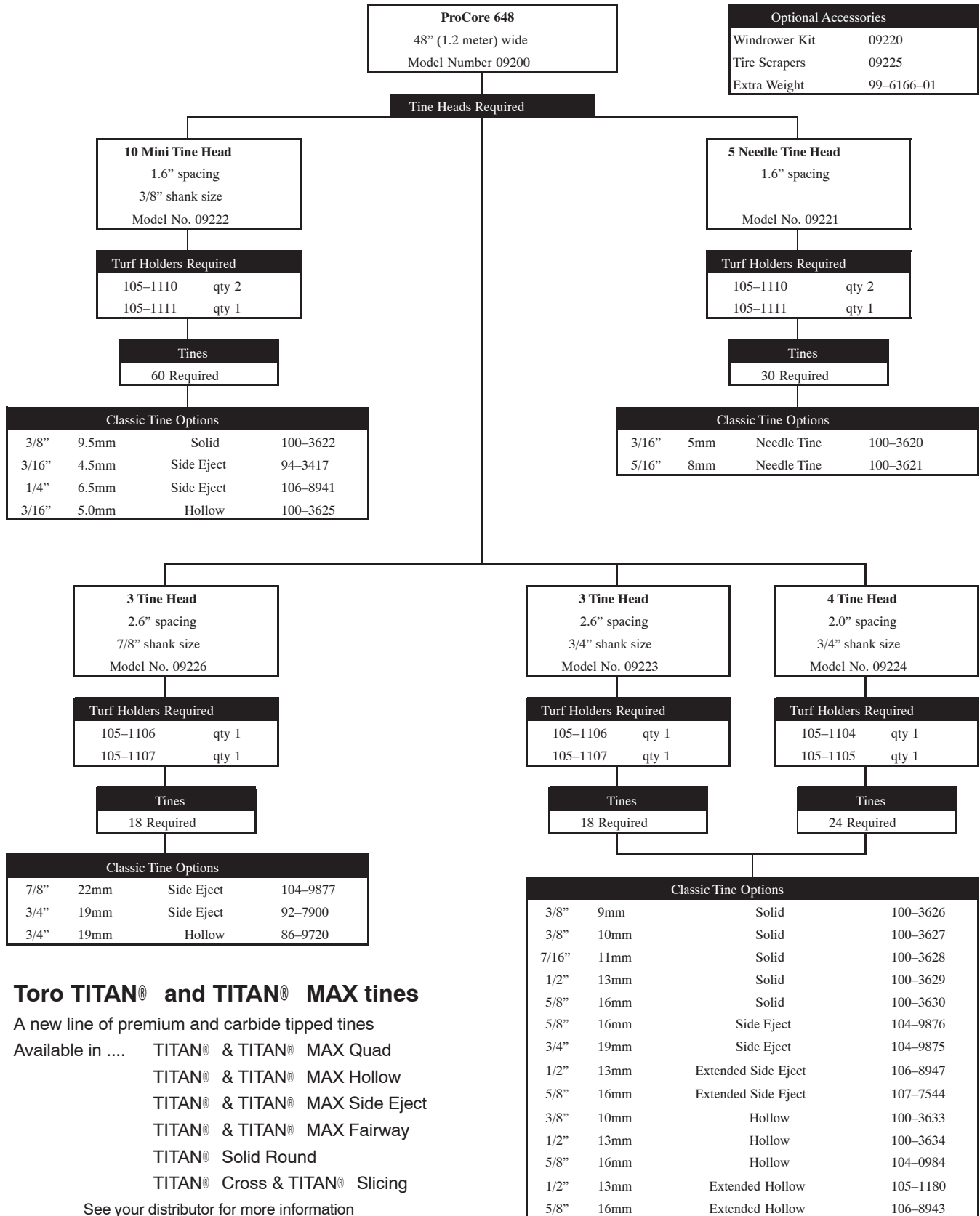

Toro TITAN® and TITAN® MAX tines

A new line of premium and carbide tipped tines

- Available in
- TITAN® & TITAN® MAX Quad
 - TITAN® & TITAN® MAX Hollow
 - TITAN® & TITAN® MAX Side Eject
 - TITAN® & TITAN® MAX Fairway
 - TITAN® Solid Round
 - TITAN® Cross & TITAN® Slicing

See your distributor for more information

Setup

Note: Determine the left and right sides of the machine from the normal operating position.

Loose Parts Chart

Note: Use this chart as a checklist to ensure all parts necessary for assembly have been shipped. If any of these parts are missing, total setup cannot be completed.

Description	Qty.	Use
Locknuts, 1/2–20	3	Install the handle to the fork
Cable guide	1	
Capscrews, 5/16 x 1/2 in.	2	
Hood plate	1	Secure rear hood for CE
Pop rivet	3	
Capscrew, #10–24 x 2 in.	1	
Nut, #10–24	1	
Locknut, #10–24	1	
Capscrew, 1/4–20 x 1 in.	1	Secure jackshaft hood for CE
Locknut, 1/4–20	1	
Carriage bolt, 5/16 x 3/4 in.	2	Secure battery cables to battery posts
Flange nut, 5/16	2	
Ignition key	2	
Carriage screw, 3/8 x 1.25 in.	12	Secure turf guards
Flat washer, 3/8	12	
Flange nut, 3/8	12	
Declaration of conformity		
Operator's manual	2	Read before operating the machine.
Engine operator's manual	1	Read before operating the machine.
Parts catalog	1	
Operator video	1	View before operating the machine
Pre-delivery check list	1	

Note: Specifications and design subject to change without notice.

Note: To raise the coring head, after uncrating the machine, start the engine and depress the RESET button. Refer to the Operation section of this manual for more information.

Install the Rear Wheels

1. Remove the (8) lug nuts securing the rear of the aerator to the packaging.
2. Mount a wheel to each hub with (4) lug nuts (Fig. 2). Torque the nuts to 45–55 ft.-lb. (61–75 N·m).

Note: Make sure a bearing plate is in position between each wheel and hub.

3. The tires are over inflated for shipping. Make sure the tire pressure is 12 psi (83 kPa) for front and rear wheels.

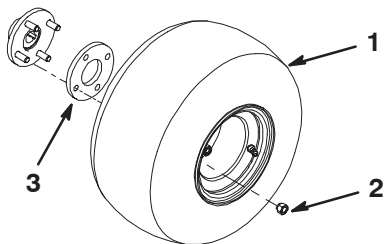

Figure 2

- | | |
|------------|------------------|
| 1. Wheel | 3. Bearing plate |
| 2. Lug nut | |

Install the Handle

1. Carefully rotate the handle to the front of the machine. Use caution not to damage cables.
2. Insert the handle mounting studs into the holes in the fork (Fig. 3).

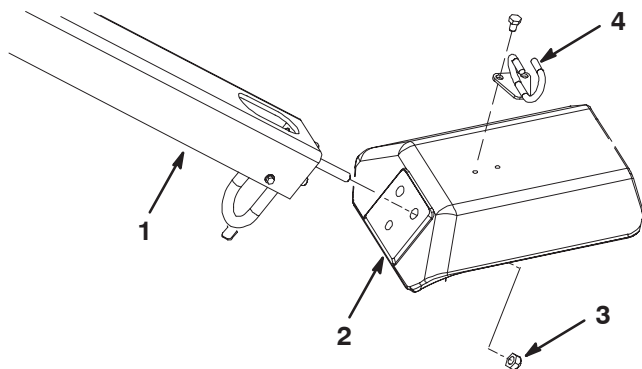

Figure 3

- | | |
|-----------|----------------|
| 1. Handle | 3. Locknut |
| 2. Fork | 4. Cable guide |
3. Secure handle studs to fork with (3) 1/2–20 locknuts (Fig. 3)

4. Insert the cable guide around the cables.
5. Mount the cable guide to the top of the fork with (2) 5/16 x 1/2" capscrews (Fig. 3).

Activate, Charge and Connect the Battery

! **Warning** !

CALIFORNIA

Proposition 65 Warning

Battery posts, terminals, and related accessories contain lead and lead compounds, chemicals known to the State of California to cause cancer and reproductive harm. *Wash hands after handling.*

1. Unlatch and open battery compartment cover.
2. Remove the battery from the battery compartment.

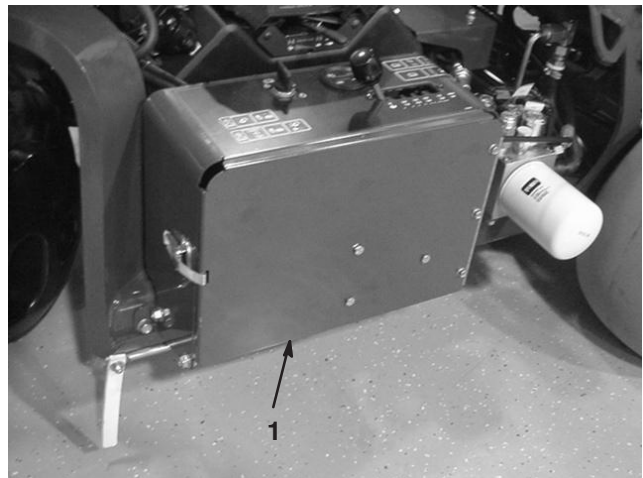

Figure 4

1. Battery compartment

Use only electrolyte (1.265 Specific Gravity) to fill battery initially.

Important Do not add electrolyte while the battery is in the machine. You could spill it, causing corrosion.

3. Clean the top of the battery and remove the vent caps.
4. Carefully fill each cell with electrolyte until the plates are covered with about 1/4 inch (6 mm) of fluid.
5. Allow approximately 20 to 30 minutes for the electrolyte to soak into the plates. Refill as necessary to bring the electrolyte to within about 1/4 inch (6 mm) of the bottom of the fill well.



Warning



Charging the battery produces gasses that can explode.

Never smoke near the battery and keep sparks and flames away from battery.

6. Connect a 3 to 4 amp battery charger to the battery posts. Charge the battery at a rate of 3 to 4 amps until the specific gravity is 1.250 or higher and the temperature is at least 60° F (16° C) with all cells gassing freely.
7. When the battery is charged, disconnect the charger from the electrical outlet and battery posts.

Note: After the battery has been activated, add only distilled water to replace normal loss, although maintenance-free batteries should not require water under normal operating conditions.



Warning



Battery terminals or metal tools could short against metal tractor components causing sparks. Sparks can cause the battery gasses to explode, resulting in personal injury.

- When removing or installing the battery, do not allow the battery terminals to touch any metal parts of the tractor.
- Do not allow metal tools to short between the battery terminals and metal parts of the tractor.

8. Insert the battery into the tray in the battery compartment (Fig. 5) Position the battery so the terminals are to the outside.
9. Secure battery to compartment base with a battery rod, (2) hold down rods, (2) flat washers and (2) wing nuts (Fig. 5).
10. First, secure the positive cable (red) to the positive (+) battery terminal with a carriage bolt and nut (Fig. 5), then the negative cable (black) to the negative (-) terminal of the battery with a carriage bolt and nut (Fig. 5). Slide the rubber boot over the positive terminal to prevent a possible short from occurring.

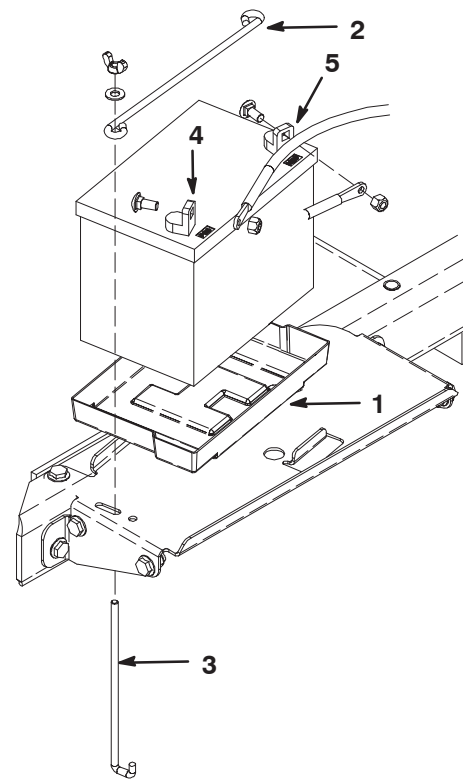

Figure 5

- | | |
|----------------------|--------------------------|
| 1. Battery tray | 4. Positive terminal (+) |
| 2. Battery hold down | 5. Negative terminal (-) |
| 3. Hold down rod | |

Important Make sure there is clearance between the battery cables and the speed selector lever. Verify that the speed selector lever does not come within 1 inch of either battery cable when it is moved through its entire range of motion. Do not wire tie or tape the negative and positive battery cables together.



Warning



Incorrect battery cable routing could damage the tractor and cables causing sparks. Sparks can cause the battery gasses to explode, resulting in personal injury.

- Always *disconnect* the negative (black) battery cable before disconnecting the positive (red) cable.
- Always *connect* the positive (red) battery cable before connecting the negative (black) cable.

11. Close and latch battery compartment cover.

Secure Rear Hood

(Required for CE)

1. Secure the hood plate to the rear hood with (3) pop rivets (Fig. 7).
2. Thread a #10 nut onto a #10 x 2 inch capscrew.
3. Insert the capscrew thru the hood plate (Fig. 7).



Figure 6

1. Rear hood

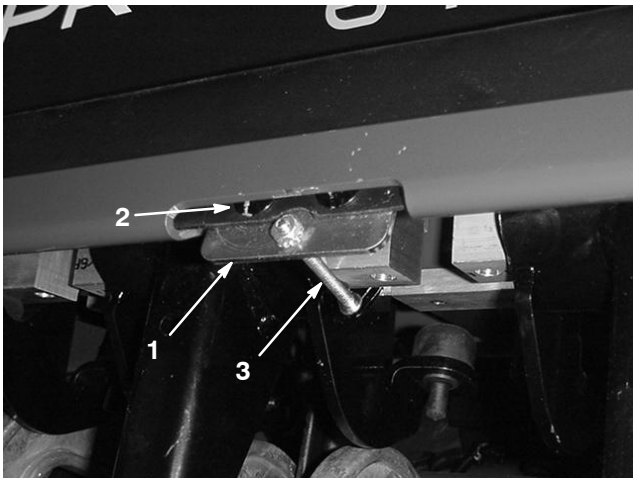

Figure 7

1. Hood plate
2. Pop rivet
3. Capscrew & nuts

4. Secure the capscrew to the hood plate with a # 10 locknut (Fig. 7).

Secure Belt Cover

(Required for CE)

1. Insert a 1/4 x 1 inch capscrew thru the belt cover latch lever and secure with a 1/4 locknut (Fig. 8 & 9).

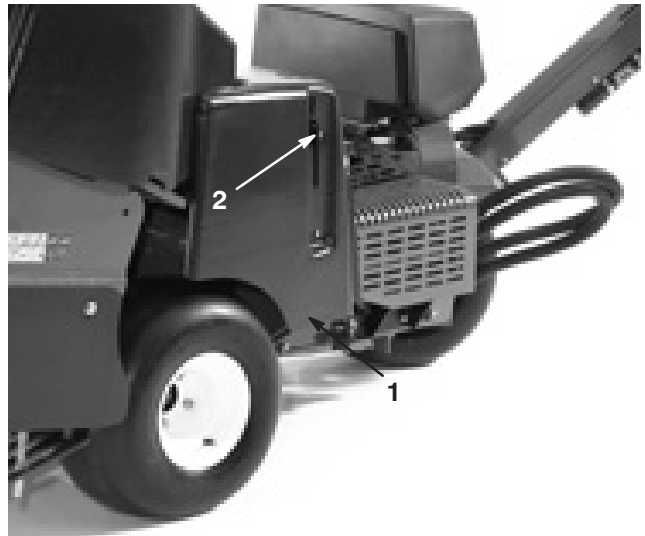

Figure 8

1. Belt cover
2. Latch lever

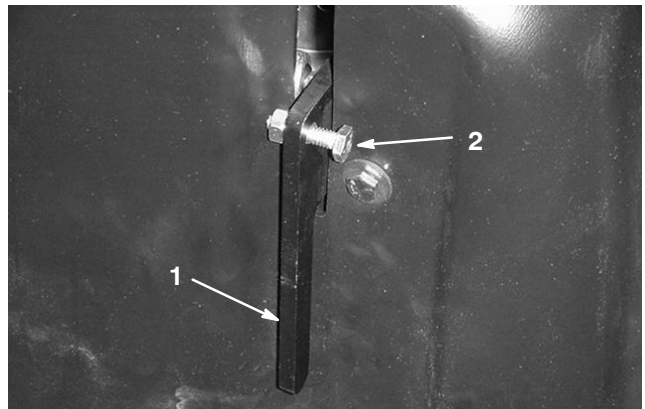

Figure 9

1. Latch lever
2. Capscrew & nut

Install Tine Holders, Turf Guards and Tines



A wide selection of tine holders, turf guards and tines are available for the aerator. Refer to page 22 for the installation instructions.

Before Operating

Recommended Gasoline

Use UNLEADED Regular Gasoline suitable for automotive use (85 pump octane minimum). Leaded regular gasoline may be used if unleaded regular is not available.

Important Never use methanol, gasoline containing methanol, or gasohol containing more than 10% ethanol because the fuel system could be damaged. Do not mix oil with gasoline.

 **Warning** 

Gasoline is harmful or fatal if swallowed. Long-term exposure to vapors can cause serious injury and illness.

- Avoid prolonged breathing of vapors.
- Keep face away from nozzle and gas tank or conditioner opening.
- Keep gas away from eyes and skin.

Using Stabilizer/Conditioner



Use a fuel stabilizer/conditioner in the aerator to provide the following benefits:

- Keeps gasoline fresh during storage of 90 days or less. For longer storage it is recommended that the fuel tank be drained.
- Cleans the engine while it runs
- Eliminates gum-like varnish buildup in the fuel system, which causes hard starting

Important Do not use fuel additives containing methanol or ethanol.

Add the correct amount of gas stabilizer/conditioner to the gas.

Note: A fuel stabilizer/conditioner is most effective when mixed with fresh gasoline. To minimize the chance of varnish deposits in the fuel system, use fuel stabilizer at all times.

 **Danger** 

In certain conditions, gasoline is extremely flammable and highly explosive. A fire or explosion from gasoline can burn you and others and can damage property.

- Fill the fuel tank outdoors, in an open area, when the engine is cold. Wipe up any gasoline that spills.
- Never fill the fuel tank inside an enclosed trailer.
- Do not fill the fuel tank completely full. Add gasoline to the fuel tank until the level is 1/4 to 1/2 inch (6 to 13 mm) below the bottom of the filler neck. This empty space in the tank allows gasoline to expand.
- Never smoke when handling gasoline, and stay away from an open flame or where gasoline fumes may be ignited by a spark.
- Store gasoline in an approved container and keep it out of the reach of children. Never buy more than a 30-day supply of gasoline.
- Always place gasoline containers on the ground away from your vehicle before filling.
- Do not fill gasoline containers inside a vehicle or on a truck or trailer bed because interior carpets or plastic truck bed liners may insulate the container and slow the loss of any static charge.
- When practical, remove gas-powered equipment from the truck or trailer and refuel the equipment with its wheels on the ground.
- If this is not possible, then refuel such equipment on a truck or trailer from a portable container, rather than from a gasoline dispenser nozzle.
- If a gasoline dispenser nozzle must be used, keep the nozzle in contact with the rim of the fuel tank or container opening at all times until fueling is complete.
- Do not operate without entire exhaust system in place and in proper working condition.

Filling the Fuel Tank

Fuel tank capacity is approximately 7.5 gal (28.4 l)

1. Stop the engine, remove the key, and wait for all moving parts to stop before leaving the operating position.
2. Clean around each fuel tank cap and remove the cap (Fig. 10). Add unleaded regular gasoline to fuel tank until the level is 1/4 to 1/2 inch (6 mm to 13 mm) below the bottom of the filler neck. This space in the tank allows gasoline to expand. Do not fill the fuel tank completely full.



Figure 10

1. Fuel tank cap

3. Install fuel tank cap securely. Wipe up any gasoline that may have spilled.

Check Engine Oil Level

Note: Check the engine oil daily and when the engine is cold.

1. Stop the engine, remove the key, and wait for all moving parts to stop before leaving the operating position.
2. Clean around the oil dipstick (Fig. 11) so dirt cannot fall into the filler hole and damage the engine.

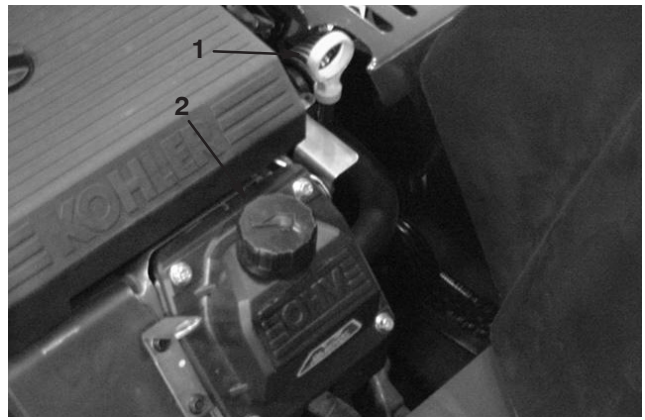

Figure 11

1. Oil dipstick
2. Filler tube

3. Pull out the oil dipstick and wipe the metal end clean (Fig. 12).
4. Slide the oil dipstick fully into the filler tube. Pull the dipstick out and look at the metal end (Fig. 12). If oil level is low, slowly pour only enough oil into the filler tube to raise the level to the full mark.

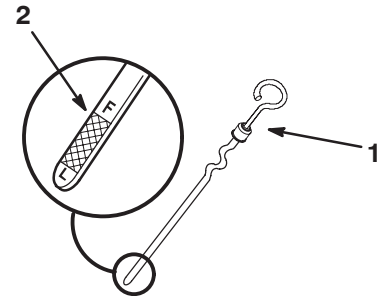

Figure 12

1. Oil dipstick
2. Metal end

Important Do not overfill the crankcase with oil because this may cause engine damage. Do not run the engine with oil below the low mark because the engine may be damaged as a result.

Check Hydraulic System Fluid

The hydraulic system is designed to operate on anti-wear hydraulic fluid. The machine's reservoir is filled at the factory with approximately 1.75 gallons of high quality hydraulic fluid. **Check level of hydraulic fluid before engine is first started and daily thereafter.** Appropriate hydraulic fluids are listed below.

The following list is not assumed to be all-inclusive. Hydraulic fluids produced by other manufacturers may be used if they can cross reference to find an equivalent to the products listed. Toro will not assume responsibility for damage caused by improper substitutions, so use only products from reputable manufacturers who will stand behind their recommendation.

Important Use only types of hydraulic fluids specified. Other fluids could cause system damage.

Group 1 Hydraulic Fluid (Moderate climate– average duty)

Note: The fluids within this group are interchangeable.

Universal Tractor Hydraulic Fluid

Mobil	Mobil Fluid 424
Amoco	1000 Fluid
Chevron	Tractor Hydraulic Fluid
Conoco	Power-Tran 3
Exxon	Torque Fluid
Pennzoil	Hydra-Tranz
Shell	Donax TD
Texaco	TDH

Important For the ProCore 648 the Group 1 fluids are recommended for use at typical ambient temperatures of 32° F (0° C) to 95° F (35° C). The Universal Tractor Fluids offer similar performance for those who prefer them, with perhaps some slight loss of efficiency at high ambient temperatures compared to the Type 46/68 fluids.

Important For operating conditions where sustained ambient temperatures are 95° F (35° C) or higher Toro highly recommends the use of Mobil 1 15W–50 synthetic oil.

Note: When changing from one type of hydraulic fluid to another, be certain to remove all the old fluid from the system, as some fluids are incompatible with others.

Group 2 Hydraulic Fluids are not recommended for use in this application

Group 3 Hydraulic Fluid (Biodegradable)

ISO VG 32/46 anti-wear hydraulic fluid

Mobil EAL Envirosyn H, ISO Grade 68

Note: This synthetic biodegradable hydraulic fluid is not compatible with the fluids in Group 1.

Note: When changing from standard fluid to the biodegradable type, be certain to follow approved flushing procedures as published by Mobil. Contact your local Toro Distributor for details.

Important Use only types of hydraulic fluids specified. Other fluids could cause system damage.

Note: A red dye additive for the hydraulic system fluid is available in 2/3 oz. bottles. One bottle is sufficient for 4–6 gal. of hydraulic fluid. Order Part No. 44–2500 from your Authorized Toro Distributor.

1. Position machine on a level surface, stop the engine, remove the key, and wait for all moving parts to stop before leaving the operating position.
2. Unlatch and remove the belt cover (Fig. 13).



Figure 13

1. Belt cover
 2. Cover latch
-
3. Clean area around filler neck and cap of hydraulic tank (Fig. 14). Remove cap from filler neck.

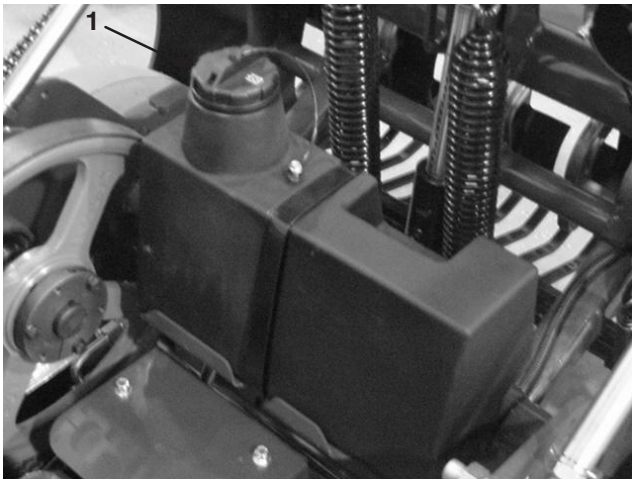

Figure 14

1. Hydraulic tank cap

4. Remove dipstick from filler neck and wipe it with a clean rag. Insert dipstick into filler neck; then remove it and check level of fluid. Fluid level should be up to mark on dipstick (Fig. 15).

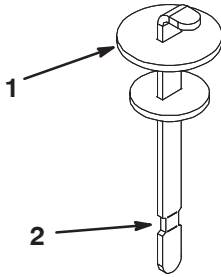

Figure 15

1. Dipstick
2. Full mark

5. If level is low, add appropriate fluid to raise level to full mark.
6. Install dipstick and cap onto filler neck.

Check the Tire Pressure

Maintain the air pressure in the front and rear tires as specified. Uneven tire pressure can cause uneven coring depth. Check the pressure at the valve stem after every 50 operating hours or monthly, whichever occurs first (Fig. 16). Check the tires when they are cold to get the most accurate pressure reading.

Pressure: 12 psi (83 kPa) front and rear wheels.

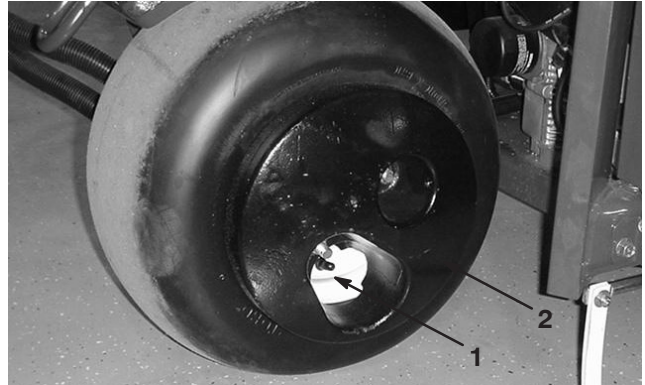

Figure 16

1. Valve stem
2. Wheel weight



Caution



The wheel weight is very heavy, 73 lbs. Use caution when removing weight from tire assembly.

Operation

Note: Determine the left and right sides of the aerator from the normal operating position (Fig. 17).

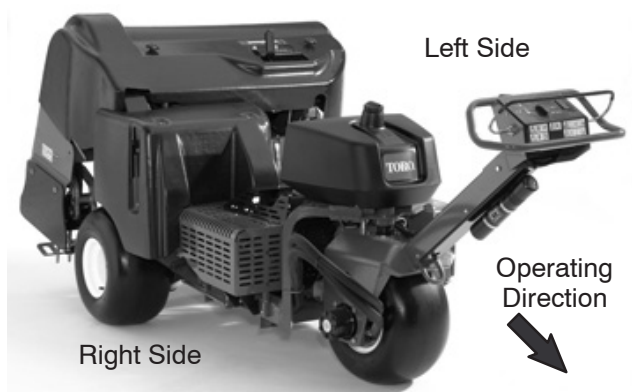

Figure 17

Controls

Become familiar with all the controls before you start the engine and operate the aerator.

Traction Lever

To move forward, move the traction lever forward. To move rearward, move the traction lever rearward (Fig. 18).

The farther you move the traction control, the faster the aerator will move.

To stop, release the traction control.

Parking Brake

To engage the parking brake, move the lever toward the engine. To disengage the parking brake, move the lever forward (Fig. 18).

Always set the parking brake when you stop the aerator or leave it unattended.

Jog traction lever forward and reverse to release parking brake.

Oil Pressure Warning Light

The oil pressure warning light (Fig. 18) glows when oil pressure in engine drops below a safe level. If low oil pressure ever occurs, stop engine and determine the cause. Repair the damage before starting the engine again.

Ignition Switch

The ignition switch (Fig. 19), which is used to start and stop the engine, has three positions: OFF, RUN, and START. Rotate key clockwise to the START position to engage starter motor. When engine starts, release key and it will move automatically to the ON position. To shut engine off, rotate key counterclockwise to the OFF position.

Raise, Lower/Engage Switch

Raise – Press the top of the switch (Fig. 18) to raise the coring head. The engine must be running to generate lift pressure. If the coring head is below the transport height, refer to System Control Circuit Reset, page 24.

Lower/Engage – Press the bottom of the switch (Fig. 18) to lower and engage the coring head. The traction lever must be in the forward position to activate the switch.

Caution

Keep hands and feet away from the coring head. Make sure the coring head area is clear of any obstructions before lowering it.

To lower the coring head without engaging the coring head, turn the ignition key to the RUN position (without the engine running), move the traction lever to the forward position and press the bottom of the switch.

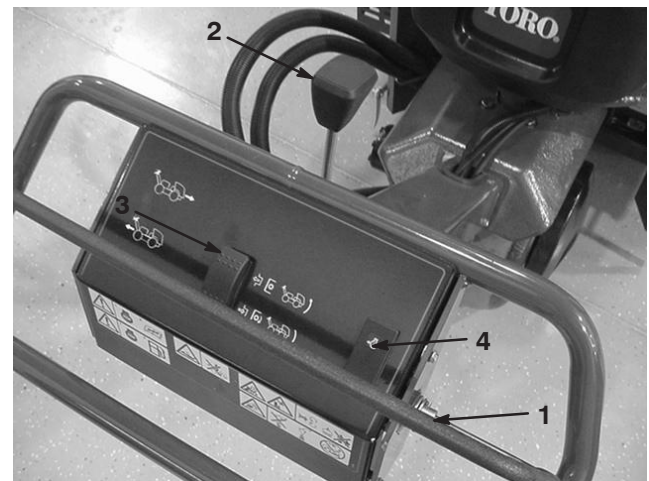

Figure 18

- | | |
|-------------------|-------------------------------|
| 1. Traction lever | 3. Raise, lower/engage switch |
| 2. Parking brake | 4. Oil pressure warning light |

Aerator Spacing Lever

Move aerator spacing lever (Fig. 19) to desired hole spacing or to “T” for transport.

Throttle Control

The throttle (Fig. 19) is used to operate engine at various speeds. Moving throttle forward increases engine speed—FAST; backward decreases engine speed—SLOW. The throttle regulates the speed of the coring head and controls the ground speed of the traction unit.



Figure 19

- | | |
|--------------------------|--------------------------|
| 1. Ignition | 5. Hour meter/tachometer |
| 2. Aerator spacing lever | 6. Manual ground follow |
| 3. Throttle | 7. System reset |
| 4. Choke | |

Hour Meter/Tachometer

When the engine is off, the hour meter/tachometer (Fig. 19) displays the number of hours of operation that have been logged on the traction unit. When the engine is running, it displays the speed of the engine in revolutions per minute (rpm).

After the first 50 hours of operation and then after every 100 hours (e.g. 150, 250, 350, etc.) the screen displays "CHG OIL" to remind you to change the engine oil. After every 100 hours (e.g. 100, 200, 300, etc.), the screen displays "SVC" to remind you to perform the other maintenance procedures based on a 100, 200, or 500 hour schedule. These reminders come on starting three hours prior to the service interval time and flash at regular intervals for six hours.

Choke

To start a cold engine, close carburetor choke by moving choke control (Fig. 19) fully forward. After engine starts, regulate choke to keep engine running smoothly. As soon as possible, open the choke by pulling it backward.

Manual Ground Follow Selector Switch

Rotate switch to down position to turn off the TrueCore™ feature (Fig. 19) Remove screw to access manual ground switch.

System Reset

Press system reset switch (Fig. 19) to raise coring head if system becomes disabled (i.e. engine out of fuel, etc.)

Aeration Depth Lever

Move lever to the desired depth of aeration (Fig. 20)

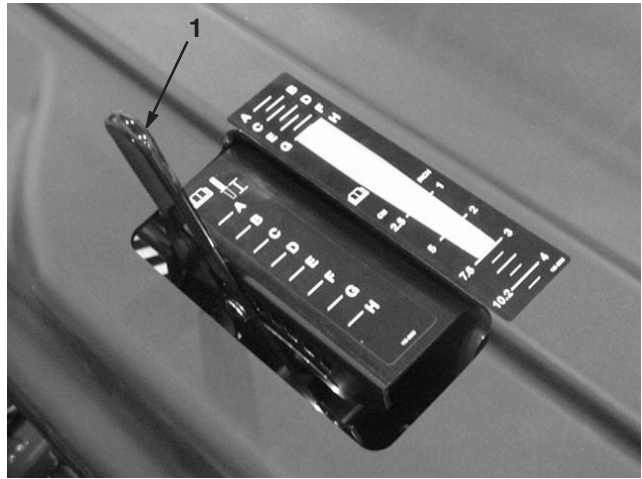

Figure 20

1. Aeration depth lever

Starting and Stopping the Engine

Starting the Engine

1. Release the traction lever (bail) and set the parking brake.
2. Move the choke control to the **on** position before starting a cold engine.

Note: A warm or hot engine may **not** require choking. After engine starts, move choke control to **run** position.

3. Move the throttle control to the **fast** position before starting a cold engine.
4. Turn the ignition key to start. When the engines starts, release the key.



Important Do not engage starter for more than 10 seconds at a time. If engine fails to start allow 30 second cool-down period between attempts. Failure to follow these instructions can burn out starter motor.

5. After the engine starts, move the choke to off . If the engine stalls or hesitates, move the choke back to on for a few seconds. Then move the throttle lever to desired setting. Repeat this as required.



Stopping the Engine

1. Move the throttle lever to the idle position.
2. Let the engine idle for 60 seconds.
3. Turn the ignition key to the off position and remove the key.
4. Close the fuel shut off valve before transporting or storing the aerator.

Important Make sure that the fuel shut off valve is closed before transporting on a trailer or storing the aerator, as fuel leakage may occur. Set the parking brake before transporting. Make sure to remove the key as the fuel pump may run and cause the battery to lose charge.

	Caution	
<p>Children or bystanders may be injured if they move or attempt to operate the aerator while it is unattended.</p> <p>Always remove the ignition key and set the parking brake when leaving the aerator unattended, even if just for a few minutes.</p>		

The Safety Interlock System

	Caution	
<p>If safety interlock switches are disconnected or damaged the aerator could operate unexpectedly causing personal injury.</p> <ul style="list-style-type: none">• Do not tamper with the interlock switches.• Check the operation of the interlock switches daily and replace any damaged switches before operating the aerator.		

Understanding the Safety Interlock System

The safety interlock system is designed to prevent the engine from starting unless the traction bail is in the neutral position.



Testing the Safety Interlock System

Test the safety interlock system before you use the aerator each time.

- Engine must only crank when the traction lever is in the neutral position.
- If traction lever is released or moved to the neutral position, the coring head should raise and stop rotating.

If the safety system does not operate as described above, have an Authorized Service Distributor repair the safety system immediately.

Service Latches

	Danger	
<p>Any time the coring head is to be serviced including changing of tines or turf guards, install the service latch to secure head in the raised position.</p>		

The service latch should also be installed when the aerator is to be stored for more than a couple days.

1. Raise coring head.
2. Remove clip ring securing service latch in storage position (Fig. 21).



1

Figure 21

1. Service latch in (lowered) storage position
3. Pivot service latch rearward and insert onto coring head pin (Fig. 22). Secure with clip ring.

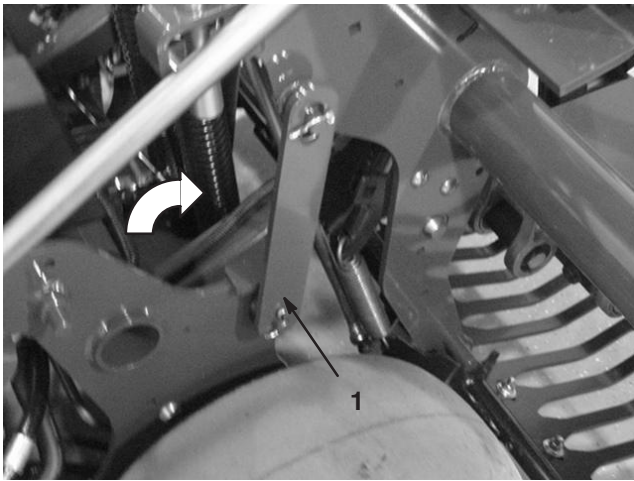

Figure 22

1. Service latch in (raised) locked position

Install Tine Holders, Turf Guards and Tines

A wide selection of tine holders, turf guards and tines are available for the aerator. Choose the required components per the accessory chart on page 10.

1. Raise coring head and lock in position with service latch.
2. Mount a tine holder to each tine arm with (3) 1/2 x 1-1/4 in. capscrews (Fig. 23). Torque capscrews to 75 ft.-lbs. (Capscrews provided in tine holder kits)

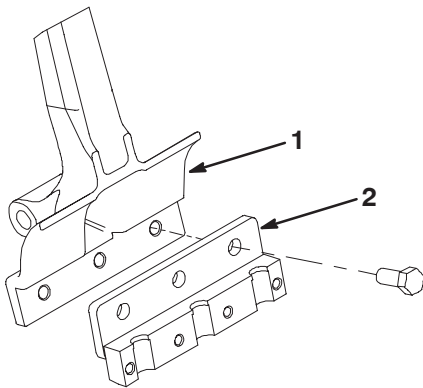

Figure 23

1. Tine arm
2. Tine holder

3. Loosely install the turf guards to the turf guard brackets with (12) carriage bolts, flat washers and flange nuts (Fig. 24). Do not tighten the fasteners. Carriage bolt heads to be positioned under turf guard brackets.

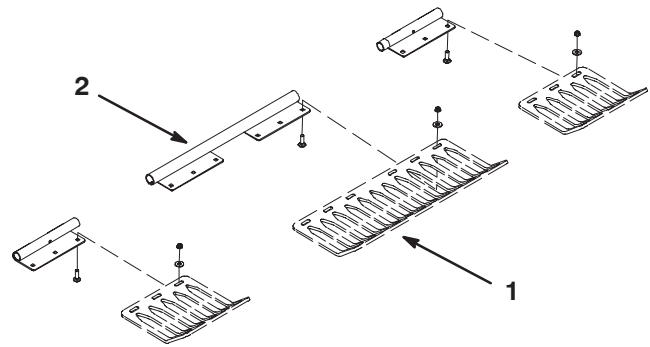

Figure 24

1. Turf guard
2. Turf guard bracket

4. Loosely install a tine clamp to each tine holder with (4) 3/8 x 1-1/2 in. capscrews. (Fig. 26) Do not tighten capscrew.
5. Install tines into the #2 and #5 tine holders (Fig. 25). Tighten the capscrews.

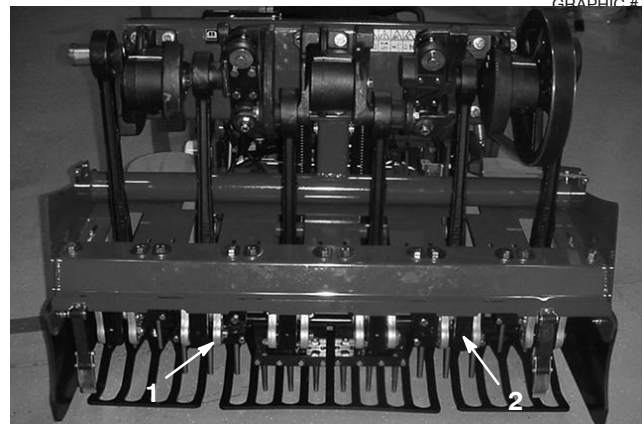

Figure 25

1. Number 5 tine holder
1. Number 2 tine holder

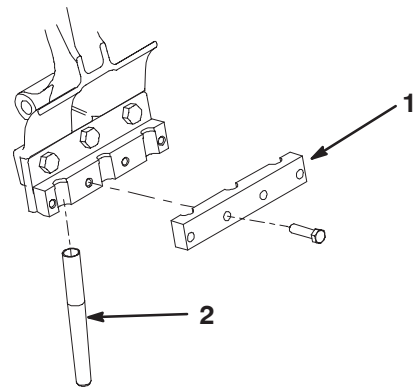

Figure 26

1. Tine clamp
2. Tine

6. Check that the tines line up with the center of the gaps in the turf guards (Fig. 27). Adjust turf guards as required and tighten the nuts.

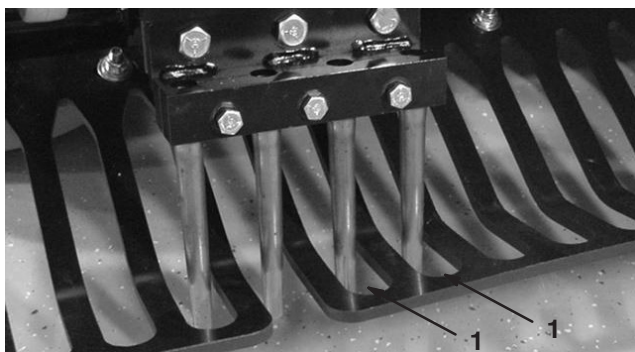

Figure 27

7. Install remaining tines into #1, 3, 4 & 6 tine holder. Torque all tine holder capscrews to 30 ft.-lbs.

When replacing all the tines, proceed as follows:

1. Raise the coring head and lock in position with the service latch.
2. Loosen the tine holder retaining capscrews and remove the old tines.
3. Insert the new tines into the tine holder.
4. Tighten the capscrews to recommended torque level.
5. Repeat procedure on remaining arms.

Setting the Coring Depth

To set the coring depth of the aerator, proceed as follows

1. Select the preferred tine for your application
2. Lay the tine on the tine depth decal (Fig. 28) with one end lined up with the desired depth of aeration (see the tine overlay on the decal).

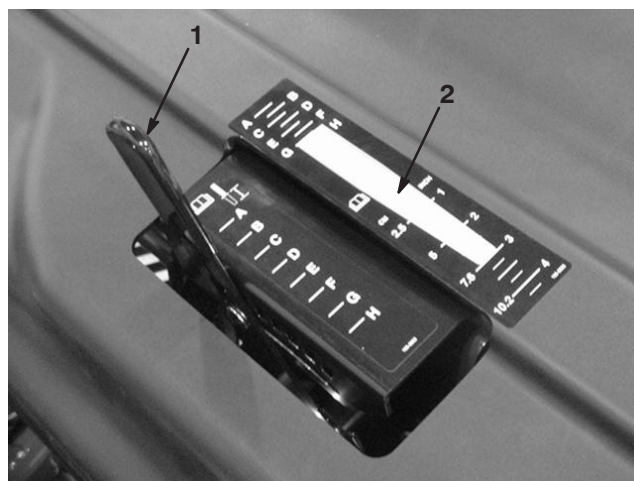

Figure 28

1. Aeration depth lever
2. Overlay on decal

3. Determine which letter setting the other end of the tine lines up with and set the depth control lever to the corresponding letter setting.

Note: As the tine wears, you may be able to reset the depth setting to account for that wear. For instance, if your new tine depth setting has you in the “G” setting, you can reset to the “H” setting after 1/4 inch of tine wear.

Manual Ground Following

The only time the manual depth setting spacers are required is if the TrueCore™ ground following system is not functioning due to damage to the feedback system (turf guards, tie rod, and actuator assembly).

To use the manual depth setting, proceed as follows:

1. Remove the lynch pin retaining the spacers and depth pins (Fig. 29).
2. Position the spacers above or below the bracket to attain the desired coring depth.
 - Thick spacers equate to 3/4 inch increments.
 - Thin spacer equates to 3/8 inch depth increment.
 - With all spacers on the top side, the depth setting is 4-1/4 inches.

To reset the system after engine is started, depress rocker switch (Fig. 32) to raise coring head and reset the electrical control circuit.

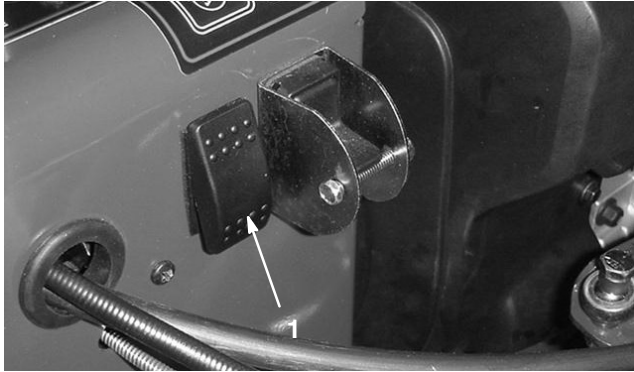

Figure 32

1. Circuit reset switch

Coring Head Stranded In Lowered Position

In the event that the engine fails or cannot be restarted with the coring head lowered and tines are engaged in the soil, proceed as follows:

- Remove the tine holders from the stomper arms.
- Open the by-pass valve one turn.
- Pull/push the aerator to a nearby location to continue service or load onto a trailer.

Important Do not pull/push aerator for more than 100 feet and no faster than 1 mph because hydraulic damage may occur.

Transporting Aerator

Trailer recommendations

Important The Hydroject trailer/tote CAN NOT be used to trailer this aerator.

Weight	1590 lbs (721 Kg) 1775 lbs (805 Kg) w/ two optional weights
Width	51 Inches min.
Length	105 Inches min.
Ramp Angle	16 degrees (3.5/12 pitch) max.
Load Direction	Coring head forward (preferred)
Vehicle Tow Capacity	Greater than Gross Trailer Weight (GTW)

Use a heavy-duty trailer or truck to transport the aerator. Ensure that the trailer or truck has all necessary lighting and marking as required by law. Please carefully read all the safety instructions. Knowing this information could help you, your family, pets or bystanders avoid injury.

To transport the aerator:

- Set the parking brake and block the wheels.
- Securely fasten the aerator tie downs (Fig. 33–35) to the trailer or truck with straps, chains, cable, or ropes.
- Secure the trailer to the towing vehicle with safety chains.

⚠
Warning
⚠

Driving on street or roadway without turn signals, lights, reflective markings, or a slow moving vehicle emblem is dangerous and can lead to accidents causing personal injury.

Do not operate aerator on a public street or roadway.

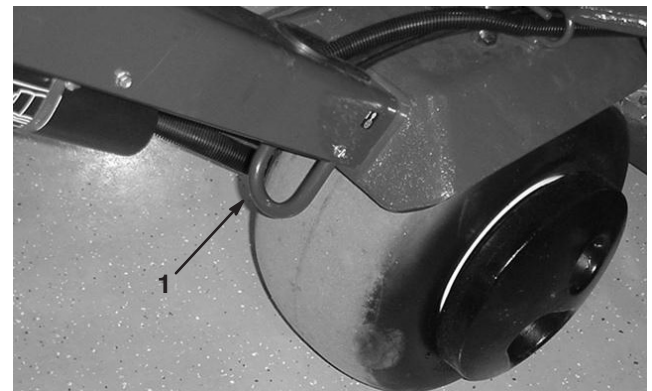

Figure 33

1. Tie down

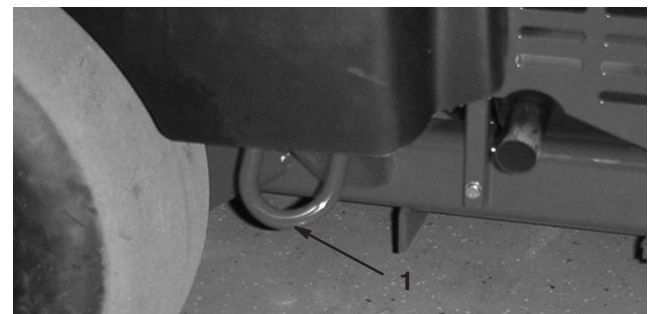

Figure 34

1. Tie down

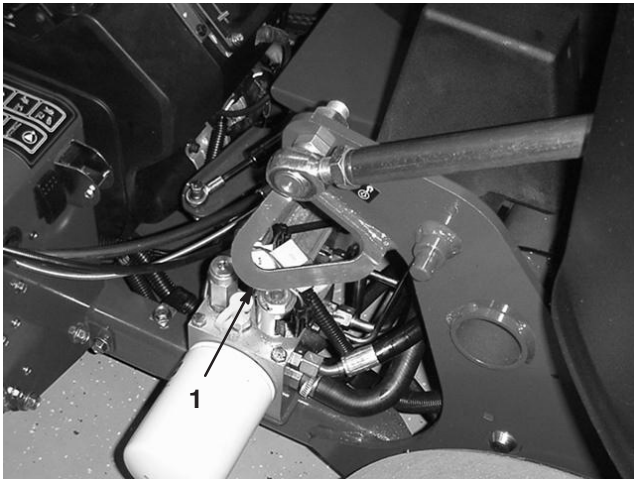

Figure 35

1. Tie down

Loading Aerator

Use extreme caution when loading the aerator on a trailer or truck. One full width ramp that is wide enough to extend beyond the rear tires is required.

The ramp should be long enough so that the angles do not exceed 16 degrees. A steeper angle may cause aerator components to get caught as the unit moves from ramp to trailer or truck. Steeper angles may also cause the unit to tip backward. If loading on or near a slope, position the trailer or truck so it is on the down side of the slope and the ramp extends up the slope. This will minimize the ramp angle. The trailer or truck should be as level as possible. Load aerator with the coring head going up the ramp first.

Important Do Not attempt to turn the unit while on the ramp; you may lose control and drive off the side.

Avoid sudden acceleration when driving up a ramp and sudden deceleration when backing down a ramp. Both maneuvers can cause the unit to tip backward.

Operating Tips

General

Make very gradual turns when aerating. Never make sharp turns with the coring head engaged. Plan your aeration path before lowering the aerator.

Look behind frequently to ensure the machine is operating properly and alignment is maintained with previous passes.

Always clear the area of all damaged machine parts, such as broken tines, etc., to prevent their being picked up by mowers or other turf maintenance equipment.

Replace broken tines, inspect and correct damage to those still useable. Repair any other machine damage before commencing operation.

The ProCore 648 will aerate deeper than most greens aerators. On native or modified push-up greens & tees, the deeper depth and longer hollow tines may have difficulty ejecting the complete core. This is due to harder native soil that sticks in the end of the tine. Side-eject greens/tees tines from Toro will stay cleaner and reduce the time required to clean the tines out. This condition is eventually eliminated with continued aeration and top-dressing programs.

Hard Ground

If the ground is too firm to obtain the desired coring depth, the coring head can get into a “bouncing” rhythm. This is due to the hard pan the tines are attempting to penetrate. This condition can be corrected by attempting the following:

- Do not aerate if ground is too hard or dry, best results are obtained after a rain or when turf has been watered the previous day.
- Change to a 3-tine head, if attempting to use the 4-tine head or reduce the number of tines per stomper arm. Attempt to maintain a symmetrical tine configuration to evenly load the stomper arms.
- Reduce aerator penetration (depth setting), if ground is hard packed. Clean up cores, water turf, and re-aerate at a deeper penetration.

Aeration of soil types built on top of hard sub-soils (i.e. soil/sand placed over rocky soil) can cause undesired hole quality. This is caused when the aeration depth is greater than the built up soil and the sub-soil is too hard to penetrate. When the tines contact this harder sub soil the aerator may lift and cause the top of the holes to become elongated. Reduce the aerating depth sufficiently to avoid penetration into the hard sub-soil.

Entrance/Exit

If the entrance/exit hole quality is deteriorating, the clutch may not be engaging soon enough. Check the following:

- The no. 3 switch location on H-Frame
- Clutch wear/slippage

If the hole quality upon entrance is slotted (pulled forward) or the coring head fails to engage before contacting the turf, the engagement position switch may require adjustment.

- Verify that the switch assembly along side the H-Frame is no more than .06 inches from the target plate
- Verify that the #3 switch is functioning properly

- If needed, loosen the switch mounting plate and lift to its highest position and re-secure the mounting plate. The higher the switch, the sooner the clutch engages

If the coring head fails to start before entrance and the position switch is located as high as permissible, the electric clutch may have deteriorated sufficiently to cause a delay in engagement. Contact your Toro distributor or refer to the ProCore 648 service manual.

Mini Tine (Quad Tine)

The mini-tine head developed by Toro is a very fast way to aerate due to the double row design. This coring head requires the hole spacing to be set at 2.5 inches. Ground speed is critical to maintain the appearance of 1.25 in. hole spacing. Refer to the hole spacing adjustment section if your hole spacing requires a small change.

With the mini tine head or larger solid tine use, the turf root structure is important to preventing turf damage due to tearing of the root zone. If the center two arms begin to lift the turf or damage to the root zone is excessive, proceed as follows:

- Increase the hole spacing
- Decrease tine size
- Remove some of the tines

This damage is caused by the lifting action that solid tines create when pulled from the turf. This lift can tear the root zone if the density of tines or diameter of tines is too high.

Front Hole Dimpled or Pushed (Solid Tines or softer soil conditions)

When aerating with longer solid tines (i.e. 3/8 in. x 4 in. long) or needle type tines, the front of the holes may become slotted or tufted. To regain excellent hole quality for this configuration, slow the engine high idle speed down to 2800 – 2900 rpm. The hole spacing is not affected as the traction and coring head speeds are both a function of engine speed.

If slowing the engine speed does not work to the remedy hole quality for the larger solid tines, the Roto-Link damper mechanism may require a stiffer setting. A stiffer Roto-Link setting may help eliminate the front of the hole from being deformed. However, under most conditions, the factory setting works best.

Note: Alter half of the Roto-Links (3 arms) and test the difference on a sample plot.

1. Remove the lock nuts securing the Roto-Link damper assembly to the coring head frame.
2. Remove the top damper-spacer (1/2 inch thick) and re-secure the Roto-Link damper assembly to the coring head frame. Be sure to use the hardened “D” washer.

3. Loosen the capscrews securing the bumper plate.
4. Slide the bumper plate forward and re-secure the capscrews. This allows the Roto-Link bumpers to oscillate properly.

Take the aerator to a test area and compare the hole quality. If improved, complete this procedure with remaining Roto-Link damper assemblies.

Note: This re-positioning of the Roto-Link damper must be reversed if the tine type is changed back to a coring style tine or any of the mini-tines.

Upon Completion

After daily use, thoroughly wash the machine with a garden hose without a nozzle so contamination and seal and bearing damage due to excessive water pressure will be avoided. A brush may be used to remove caked-on material. Use mild detergent to clean the covers. Applying a coat of auto wax periodically will retain the cover's glossy finish. After cleaning, inspect for machine damage, oil leakage, component and tine wear.

Remove clean and oil the tines. Spray a light oil mist on coring head bearings (crank & damper links).

Secure service latch if the aerator is to be stored for more than a couple days.

Using Line Marker

Use the line marker to align aeration rows (Fig. 36).

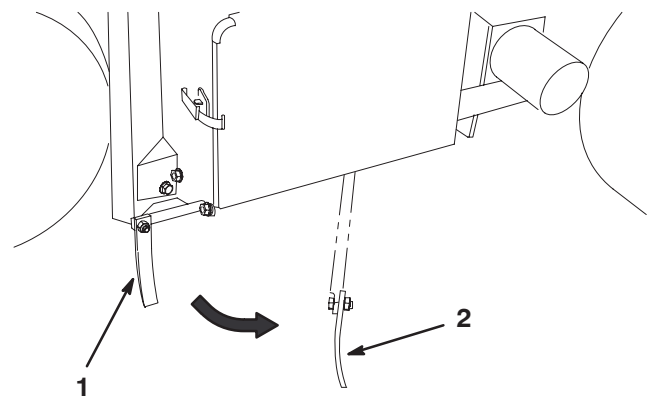

Figure 36

1. Line marker (storage position)
2. Line marker (alignment position)

Adjusting Weight Transfer

The ProCore 648 is designed to transfer weight from the traction unit to the coring head to help maintain hole depth in various soil structures. However, if the soil structure is firm enough to not allow full aeration depth

some additional weight transfer may be required. To increase the down pressure of the weight transfer springs, proceed as follows:

Warning

Sudden release of the spring plates could cause injury.

Acquire the help of another person to help adjust the weight transfer spring.

1. Loosen the carriage bolt nuts securing the spring brackets to the coring head. Do not remove (Fig. 37).

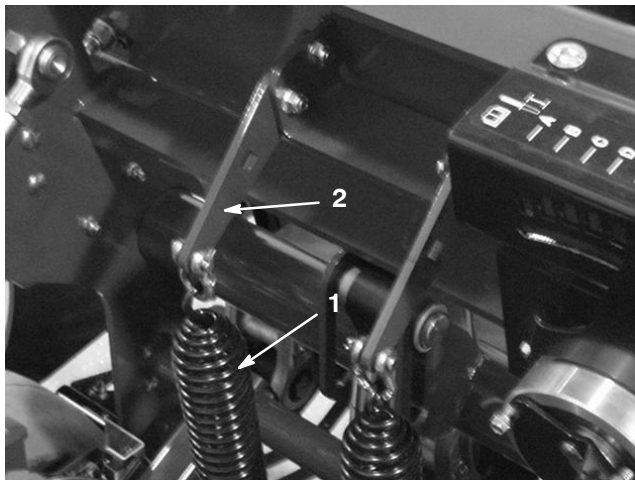

Figure 37

1. Weight transfer springs
2. Spring plate

2. Insert a 1/2 inch ratchet or breaker-bar into the square hole in the spring plate (Fig. 38).

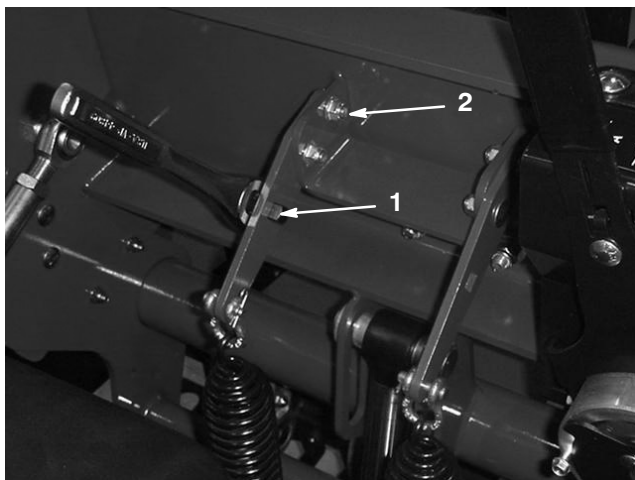

Figure 38

1. Square hole in bracket
2. Rear carriage bolt

3. Hold the ratchet or breaker-bar to relieve the tension on the spring plate and remove the rear carriage bolt.
4. Rotate the spring plate until it is aligned with the other hole, insert the carriage bolt and tighten nuts.

Note: Rotating spring plates upward will increase weight transfer.

Additional Weight

With the increased weight transfer, it is possible to aerate firm enough ground that the weight transfer begins to lift the rear two tires off the ground. This may lead to irregular hole spacing.

If this occurs, an additional weight plate can be added to the rear frame axle tube. Each cast weight adds 63 lbs (28.5 Kg) to the traction unit. Up to two plates can be added. Refer to parts catalog for these part numbers.

Aerator Control Module (ACM)

The Aerator Control Module is a "potted" electronic device produced in a "one size fits all" configuration. The module uses solid state and mechanical components to monitor and control electrical features required for safe product operation.



Figure 39

1. Standard control module

The module monitors inputs including head low, head high, transport, aerate and ground following. The module is divided into inputs and outputs. Inputs and outputs are identified by green LED indicators mounted on the printed circuit board. Power is identified by a red LED indicator.

The start circuit input is energized by 12 VDC. All other inputs are energized when the circuit is closed to ground. Each input has a LED that is illuminated when the specific circuit is energized. Use the input LED's for switch and input circuit troubleshooting.

Output circuits are energized by an appropriate set of input conditions. The three outputs include SVL, SVR and SVQ. Output LED's monitor relay condition indicating the presence of voltage at one of three specific output terminals.

Output circuits do not determine output device integrity so electrical troubleshooting includes output LED inspection and conventional device and wire harness integrity testing. Measure disconnected component impedance, impedance through wire harness (disconnect at ACM), or by temporarily "test energizing" the specific component.

The ACM does not connect to an external computer or hand held device, can not be re-programmed, and does not record intermittent fault troubleshooting data.

The decal on the ACM only includes symbols. Three LED output symbols are shown in the output box. All other LED's are inputs. The chart below identifies the symbols.

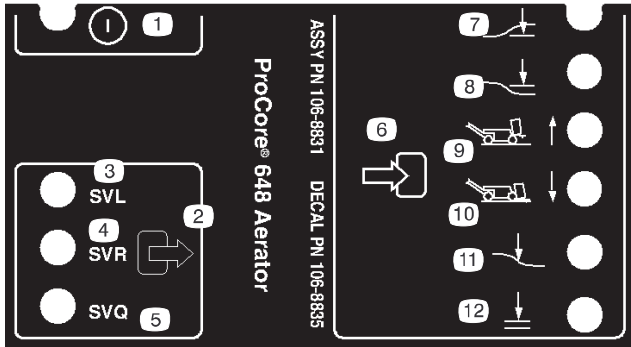

- | | |
|-------------------------|----------------------|
| 1. On/off | 7. Head low |
| 2. Output | 8. Head high |
| 3. Solenoid valve lower | 9. Transport |
| 4. Solenoid valve raise | 10. Aerate |
| 5. Solenoid valve quick | 11. Ground following |
| 6. Input | 12. OK to lower |

- If specific output LED is not illuminated and inputs are in appropriate condition, install new ACM and determine if fault disappears.

Here are the logical troubleshooting steps for the ACM device.

- Determine the output fault you are trying to resolve.
- Move key switch to "ON" and ensure the red "power" LED is illuminated.
- Move all input switches to ensure all LED's change state.
- Position input devices at appropriate position to achieve the appropriate output.
- If specific output LED is illuminated without appropriate output function, check output harness, connections, and component. Repair as required.
- If specific output LED is not illuminated, check both fuses.

Maintenance

Recommended Maintenance Schedule

Maintenance Service Interval	Maintenance Procedure
After first 8 hours	<ul style="list-style-type: none"> Hydraulic fluid—check level Hydraulic return filter—change Hydraulic charge filter—change Pump belt—re-tension Coring head fasteners—check torque
After first 50 Hours	<ul style="list-style-type: none"> Engine oil & filter—change
Each Use	<ul style="list-style-type: none"> Engine oil—check level Safety System—check Engine air intake—clean¹ Belts—check Hydraulic fluid—check level Tires—check pressure Hydraulic lines—check
Every 25 Hours	<ul style="list-style-type: none"> Wash and re-oil air precleaner Battery—check electrolyte
Every 100 Hours	<ul style="list-style-type: none"> Engine oil & filter—change¹ Primary air cleaner filter—replace¹ Fuel filter—replace Engine cooling system—clean¹
Every 200 Hours	<ul style="list-style-type: none"> Hydraulic fluid—change Hydraulic return filter—change Hydraulic charge filter—change Spark Plug(s)—check
Every 500 Hours	<ul style="list-style-type: none"> Spark Plug(s)—replace
Before Storage Service	<ul style="list-style-type: none"> Battery—charge, Disconnect cables Gasoline—drain Chipped Surfaces—paint Perform all maintenance procedures listed above before storage

¹More often in dusty, dirty conditions

Important Refer to your engine operator's manual for additional maintenance procedures.

Daily Maintenance Checklist

Duplicate this page for routine use.

Maintenance Check Item	For the week of:						
	Mon.	Tues.	Wed.	Thurs.	Fri.	Sat.	Sun.
Check safety interlock operation.							
Check parking brake operation.							
Check fuel level							
Check the engine oil level.							
Check the air cleaner.							
Check the engine for debris.							
Check unusual engine noises.							
Check unusual operating noises.							
Check the hydraulic fluid level.							
Check the hydraulic hoses for damage.							
Check for fluid leaks.							
Check the tire pressure.							
Check instrument operation.							
Check the condition of the tines.							
Touch up damaged paint.							

Inspection performed by:		
Item	Date	Information
1		
2		
3		
4		
5		
6		
7		
8		
9		
10		

Caution
<p>If you leave the key in the ignition switch, someone could accidentally start the engine and seriously injure you or other bystanders.</p> <p>Remove the key from the ignition and disconnect the wire from the spark plug(s) before you do any maintenance. Set the wire aside so that it does not accidentally contact the spark plug.</p>

Lubrication

The aerator has no grease fittings that must be lubricated.

Important Bearings rarely fail from defects in materials or workmanship. The most common reason for failure is moisture and contamination working its way past the protective seals. Bearings that are greased will rely upon regular maintenance to purge harmful debris from the bearing area. Sealed bearings rely on an initial fill of special grease and a robust integral seal to keep contaminants and moisture out of the rolling elements.

The sealed bearings require no lubrication or short term maintenance. This minimizes routine service required and reduces the potential of turf damage due to grease contamination. These sealed bearing packages will provide good performance and life under normal use, but periodic inspections of bearing condition and seal integrity should be conducted to avoid downtime. These bearings should be inspected seasonally and replaced if damaged or worn. Bearings should operate smoothly with no detrimental characteristics such as high heat, noise, looseness or rust weeping.

Due to the operating conditions these bearing/seal packages are subject to (i.e. sand, turf chemicals, water, impacts, etc.) they are considered normal wear items. Bearings that fail due to other than defects in materials or workmanship are typically not covered under warranty.

Note: Bearing life can be negatively affected by improper wash down procedures. Do not wash down the unit when it is still hot and avoid directing high-pressure or high volume spray at the bearings.

It is not uncommon for new bearings to purge some grease out the seals on a new unit. This purged grease will turn black in color due to collection of debris and not due to excessive heat. It is good practice to wipe this excess grease from the seals after the initial 8 hours. There may always appear to be a wet area around the seal lip. This is generally not detrimental to bearing life, but keeps the seal lip lubricated.

Coring head bearing replacement is suggested at intervals of 500 hours. A bearing service kit which covers the complete coring head is available from your distributor.

Jacking Instructions

Caution

When changing attachments, tires or performing other service, use correct blocks, hoists and jacks. Make sure machine is parked on a solid level surface such as a concrete floor. Prior to raising machine, remove any attachments that may interfere with the safe and proper raising of the machine. Always chock or block wheels. Use jack stands or solid wood blocks to support the raised machine. If the machine is not properly supported by blocks or jack stands, the machine may move or fall, which may result in personal injury.

Jacking the Front End

1. Set the parking brake and chock the rear tires to prevent the machine from moving.

Important To prevent wheel motor damage, DO NOT use front wheel motor as a jacking point.

2. Position the jack securely under the front of the frame (Fig. 40).

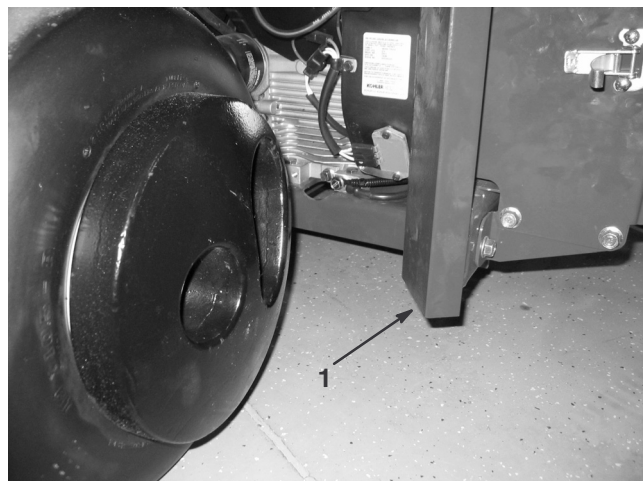

Figure 40

1. Frame

3. Jack the front of the machine off the ground.
4. Position the jack stands or hardwood blocks under the front of the frame to support the machine.

Jacking the Rear End

1. Chock the front tire to prevent the machine from moving.

Important To prevent wheel motor damage, DO NOT use rear wheel motor as a jacking point.

2. Place the jack securely under the frame plate just inside of the rear wheel (Fig. 41).

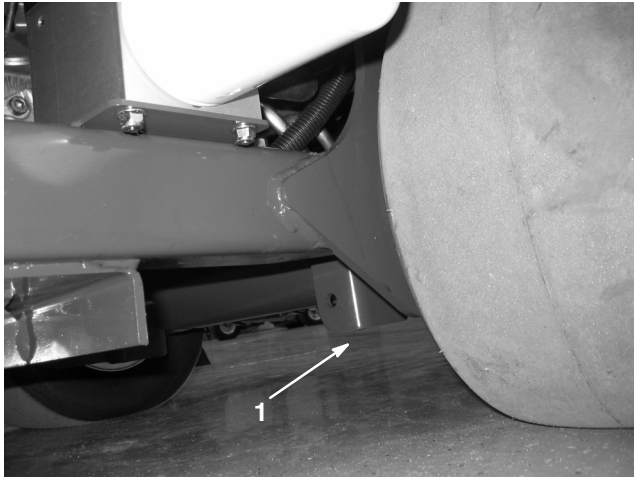

Figure 41

1. Frame plate

Note: If available, a hoist can be used to lift the rear of the ProCore 648. Use eyelets in coring head bearing housings as hoist attachment points (Fig. 42).

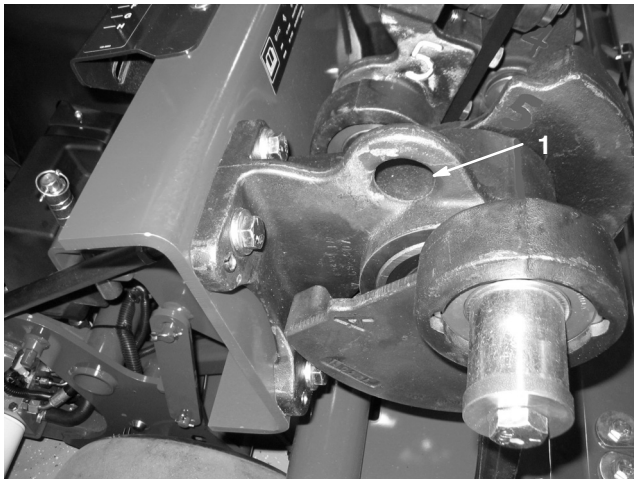

Figure 42

1. Lifting eyelet

3. Jack (or lift) the rear of the machine off the ground.
4. Position the jack stands or hardwood blocks under the frame to support the machine.

Servicing the Air Cleaner

The foam pre-cleaner must be cleaned and re-oiled after every 25 hours engine operation if engine is operated in clean air conditions. However, air cleaner must be cleaned more frequently if operating conditions are extremely dusty or sandy.

1. Remove knob, O-ring and cover (Fig. 43).
2. Remove foam pre-cleaner by sliding it off the paper element.
 - Wash foam pre-cleaner in detergent and warm water.
 - Wrap foam pre-cleaner in cloth and squeeze dry. Do not wring pre-cleaner. Allow to air dry.
 - Saturate foam pre-cleaner in engine oil. Squeeze to remove excess oil.

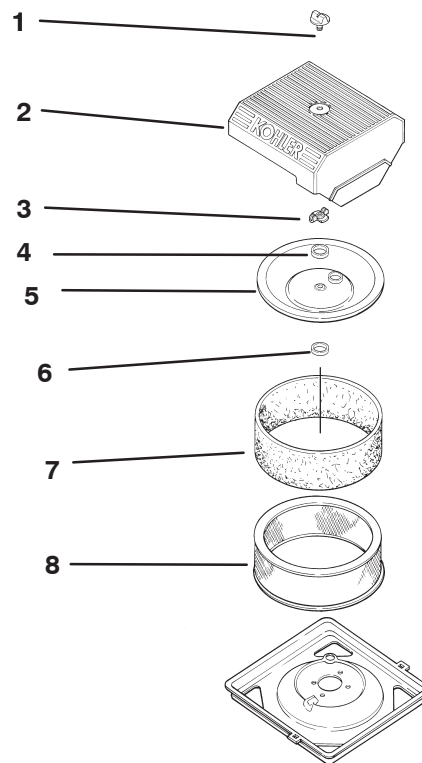

Figure 43

- | | |
|----------------------|---------------------|
| 1. Knob & O-ring | 5. Inner cover |
| 2. Air cleaner cover | 6. Breather seal |
| 3. Nut | 7. Foam pre-cleaner |
| 4. Spacer | 8. Paper element |

3. Reinstall on paper cartridge.

Inspect paper element every 25 hours of operation and replace if dirty or damaged. Change paper element every 100 hours. Do not wash paper element or do not clean with compressed air as damage will occur.

Note: With air cleaner disassembled, check air cleaner components for damage. Replace if necessary.

1. Reinstall element with pre-cleaner, breather seal, spacer, inner cover and nut. Torque nut to 95 in.-lb. (11 N·m).
2. Reinstall air cleaner cover, O-ring and knob.
3. Tighten knob 1/2 to 1 turn after knob contacts cover. Do not overtighten.

Servicing the Engine Oil

Change oil:

- After every 100 operating hours.

Note: Change oil more frequently when operating conditions are extremely dusty or sandy.

Oil Type: Detergent oil (API service SH, SJ, SL or higher)

Crankcase Capacity: w/filter, 2 qt. (1.9 l)

Viscosity: See table

USE THESE SAE VISCOSITY OILS

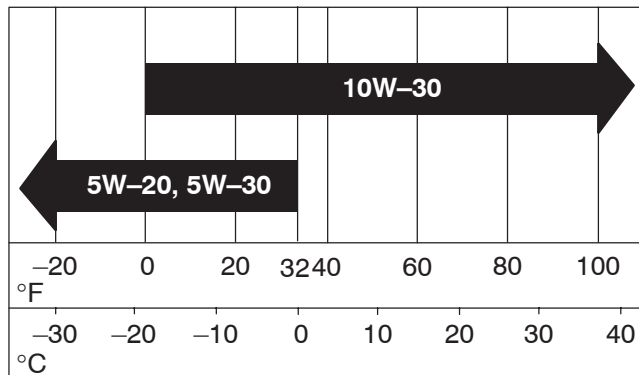

Note: SAE 30 weight is approved for this application.

Checking the Oil Level

Note: Check the oil when the engine is cold.

1. and set the parking brake.
2. Stop the engine, remove the key, and wait for all moving parts to stop before leaving the operating position.
3. Clean around the oil dipstick (Fig. 44) so dirt cannot fall into the filler hole and damage the engine.
4. Pull the oil dipstick and wipe the metal end clean.

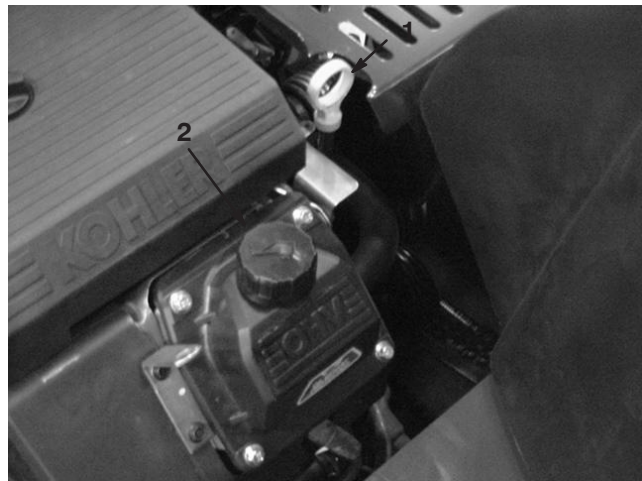

Figure 44

1. Oil dipstick
2. Filler tube

5. Slide the oil dipstick fully into the filler tube. Pull the dipstick out and look at the metal end (Fig. 45). If oil level is low, slowly pour only enough oil into the filler tube to raise the level to the full mark.

Important Do not overfill the crankcase with oil because this may cause engine damage. Do not run the engine with oil below the low mark because the engine may be damaged as a result.

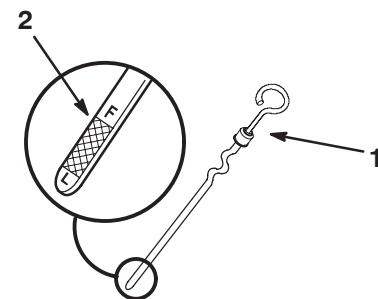

Figure 45

1. Oil dipstick
2. Metal end

Changing the Oil

1. Start the engine and let it run five minutes. This warms the oil so it drains better.
2. Park the machine so that the drain side is slightly lower than the opposite side to assure the oil drains completely. Set the parking brake, and turn the ignition key to off. Remove the key.
3. Place a pan below the oil drain. Remove the oil drain plug to allow oil to drain (Fig. 46).

- When the oil has drained completely, install the drain plug.

Note: Dispose of the used oil at a certified recycling center.

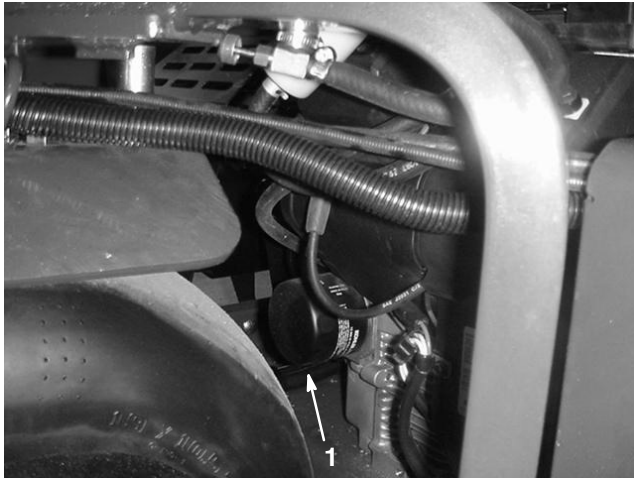

Figure 46

- Oil filter

- Slowly pour approximately 80% of the specified oil into the filler cap (Fig. 44). Refer to Servicing the Engine Oil, page 34.
- Check the oil level; refer to Checking the Oil Level, page 34.
- Slowly add additional oil to bring it to the full mark.

Change the Oil Filter

Replace the oil filter every 100 hours or at every oil change.

Note: Change the oil filter more frequently when operating conditions are extremely dusty or sandy.

- Drain the oil from the engine; refer to Changing the Oil, page 34.
- Remove the old filter and wipe the filter adapter (Fig. 47) gasket surface.
- Pour new oil of the proper type in through the center hole. Stop pouring when the oil reaches the bottom of the threads. Allow a minute or two for the oil to be absorbed by filter material.
- Apply a thin coat of new oil to the rubber gasket on the replacement filter (Fig. 47).

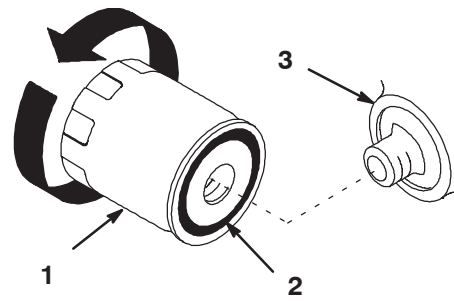

m-1256

Figure 47

- Oil filter
- Gasket
- Adapter

- Install the replacement oil filter to the filter adapter. Turn the oil filter clockwise until the rubber gasket contacts the filter adapter, then tighten the filter an additional 1/2 turn (Fig. 47).
- Fill the crankcase with the proper type of new oil; refer to Changing the Oil, page 34.

Servicing the Spark Plug

Check the spark plug(s) after every 200 operating hours. Make sure the air gap between the center and side electrodes is correct before installing the spark plug. Use a spark plug wrench for removing and installing the spark plug(s) and a gapping tool/feeler gauge to check and adjust the air gap. Install a new spark plug(s) if necessary.

Type: Champion RC12YC (or equivalent)

Air Gap: 0.030 inch (0.76 mm)

Removing the Spark Plug(s)

- Set the parking brake, stop the engine, remove the key, and wait for all moving parts to stop before leaving the operating position.
- Pull the wire(s) off the spark plug(s) (Fig. 48). Now clean around the spark plug(s) to prevent dirt from falling into the engine and potentially causing damage.
- Remove the spark plug(s) and metal washer.

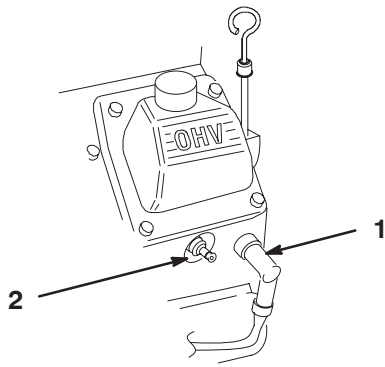

m-4811

Figure 48

1. Spark plug wire
2. Spark plug

Checking the Spark Plug

1. Look at the center of the spark plug(s) (Fig. 49). If you see light brown or gray on the insulator, the engine is operating properly. A black coating on the insulator usually means the air cleaner is dirty.

Important Never clean the spark plug(s). Always replace the spark plug(s) when it has: a black coating, worn electrodes, an oily film, or cracks.

2. Check the gap between the center and side electrodes (Fig. 49). Bend the side electrode (Fig. 49) if the gap is not correct.

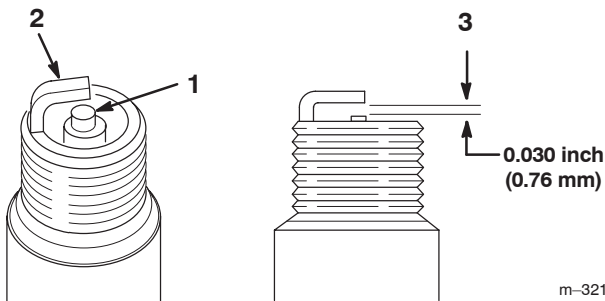

m-3215

Figure 49

1. Center electrode insulator
2. Side electrode
3. Air gap (not to scale)

Installing the Spark Plug(s)

1. Install the spark plug(s). Make sure the air gap is set correctly.
2. Tighten the spark plug(s) to 20 ft-lb (27 N·m).
3. Push the wire(s) onto the spark plug(s) (Fig. 48).

Servicing the Fuel Filter

Replace the fuel filter after every 100 operating hours or yearly, whichever occurs first.

Replacing the Fuel Filter

Never install a dirty filter if it is removed from the fuel line.

1. Allow the machine to cool down.
2. Set the parking brake, stop the engine, remove the key, and wait for all moving parts to stop before leaving the operating position.
3. Close the fuel shut-off valve (Fig. 50).

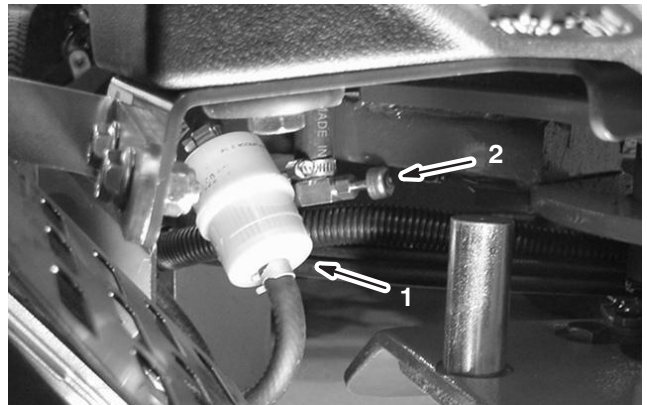

Figure 50

1. Fuel filter
2. Fuel shut-off valve

4. Squeeze the ends of the hose clamps together and slide them away from the filter (Fig. 50).
5. Remove the filter from the fuel lines.
6. Install a new filter and move the hose clamps close to the filter (Fig. 50).
7. Wipe up any spilled fuel.
8. Open fuel shut-off valve (Fig. 50).

Servicing the Fuel Tank

Draining The Fuel Tank



Danger



In certain conditions, gasoline is extremely flammable and highly explosive. A fire or explosion from gasoline can burn you and others and can damage property.

- Drain gasoline from the fuel tank when the engine is cold. Do this outdoors in an open area. Wipe up any gasoline that spills.
- Never smoke when draining gasoline, and stay away from an open flame or where a spark may ignite the gasoline fumes.

1. Park the machine on a level surface, to ensure the fuel tank drains completely. Then, set the parking brake, and turn the ignition key to off. Remove the key.
2. Close the fuel shut-off valve (Fig. 50).
3. Loosen the hose clamp at the fuel filter and slide it up the fuel line away from the fuel filter (Fig. 50).
4. Pull the fuel line off fuel filter (Fig. 50). Open fuel shut-off valve and allow gasoline to drain into a gas can or drain pan.

Note: Now is the best time to install a new fuel filter because the fuel tank is empty.

5. Install the fuel line onto the fuel filter. Slide the hose clamp close to the fuel filter to secure the fuel line (Fig. 50).

Cleaning the Cooling Systems

Cleaning the Engine Screen

Before each use, check and clean engine screen. Remove any build-up of grass, dirt or other debris from the engine air intake screen.

Servicing the Hydraulic System

Replacing the Hydraulic Filters

Change the hydraulic filters:

- After the first 8 operating hours.
- After every 200 operating hours.



Warning



Hydraulic fluid escaping under pressure can penetrate skin and cause injury.

- If hydraulic fluid is injected into the skin it must be surgically removed within a few hours by a doctor familiar with this type of injury. Gangrene may result if this is not done.
- Keep body and hands away from pin hole leaks or nozzles that eject high pressure hydraulic fluid.
- Use cardboard or paper to find hydraulic leaks.
- Safely relieve all pressure in the hydraulic system before performing any work on the hydraulic system.
- Make sure all hydraulic fluid hoses and lines are in good condition and all hydraulic connections and fittings are tight before applying pressure to hydraulic system.

Important Do not substitute automotive oil filters or severe hydraulic system damage may result.

Note: Removing the return filter will drain the entire oil reservoir.

1. Set the parking brake, stop the engine, remove the key, and wait for all moving parts to stop before leaving the operating position.
2. Place a drain pan under the filters, remove the old filters and wipe the filter adapter gasket surface clean (Fig. 51).

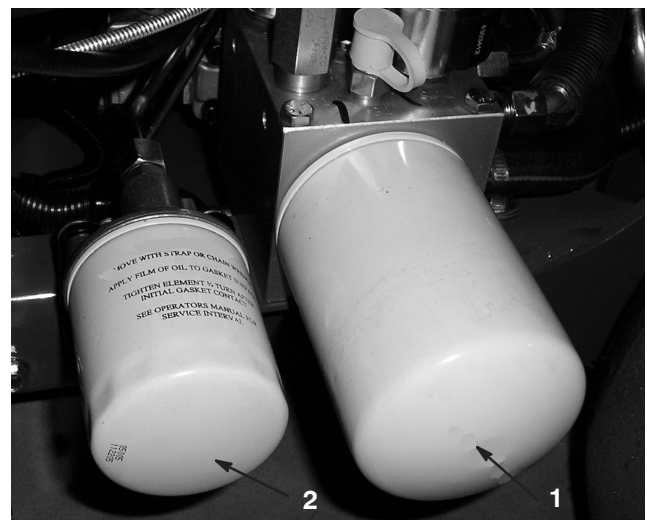

Figure 51

1. Hydraulic return filter
 2. Hydraulic charge filter
3. Apply a thin coat of hydro fluid to the rubber gasket on the replacement filters.

4. Install the replacement hydraulic filters onto the filter adapters. Turn the hydraulic oil filter clockwise until the rubber gasket contacts the filter adapter, then tighten the filter an additional 1/2 turn
5. Add fluid to the FULL mark on the dipstick, refer to Checking the Hydraulic Fluid, page 17.
6. Start the engine and let it run for about two minutes to purge air from the system. Stop the engine and check for leaks.
7. Recheck level while fluid is warm. Add fluid to raise the level to the FULL mark on the dipstick, if required. **Do not overfill.**

Hydraulic System Test Ports

The test ports are used to test pressure in the hydraulic circuits. Contact your local Toro distributor for assistance.

Test Port G 2 (Fig. 52) is used to assist in trouble shooting the traction charge circuit.

Test Port G 1 (Fig. 52) is used to assist in trouble shooting the lift circuit pressure.

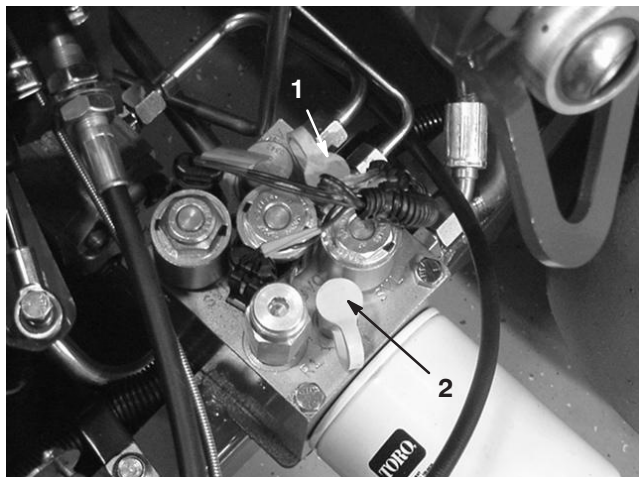

Figure 52

1. Test port G2
2. Test port G1

Adjusting the Traction Drive for Neutral

The machine must not creep when traction lever is released. If it does creep, an adjustment is required.

1. Park the aerator on a level surface shut the engine off, and engage the parking brake.
2. Jack up the machine so the front wheel and one rear wheel is just off the ground. Place jack stands under machine. Refer to Jacking Instructions.

3. Loosen the locknut on the traction adjustment cam (Fig. 53).



Figure 53

1. Traction adjustment cam



Warning



The engine must be running so the final adjustment of the traction adjustment cam can be performed. This could cause personal injury.

Keep hands, feet, face, and other body parts away from the muffler, other hot parts of the engine, and any rotating parts.

4. Start engine and release the parking brake.
5. Rotate cam hex in either direction until the wheels do not rotate.
6. Tighten locknut securing adjustment.
7. Stop the engine.
8. Remove the jack stands and lower the machine to the ground.
9. Test the machine to make sure it does not creep.

Checking the Hydraulic Lines

Before each use, check the hydraulic lines and hoses for leaks, loose fittings, kinked lines, loose mounting supports, wear, weather and chemical deterioration. Make necessary repairs before operating.

Note: Keep areas around hydraulic system clean from debris build up.



Warning



Hydraulic fluid escaping under pressure can penetrate skin and cause injury.

- If hydraulic fluid is injected into the skin it must be surgically removed within a few hours by a doctor familiar with this type of injury. Gangrene may result if this is not done.
- Keep body and hands away from pin hole leaks or nozzles that eject high pressure hydraulic fluid.
- Use cardboard or paper to find hydraulic leaks.
- Safely relieve all pressure in the hydraulic system before performing any work on the hydraulic system.
- Make sure all hydraulic fluid hoses and lines are in good condition and all hydraulic connections and fittings are tight before applying pressure to hydraulic system.

Re-setting Ground Following System

If the True Core ground following system requires service of any kind (with exception of turf guard replacement) or if the tine holders are contacting the turf guards when set in the deepest setting, the depth adjustment tie rod may need to be re-set.

1. Rotate the LH turf guard mounting bracket (Fig. 54) up until a locking pin (5/16 drill rod or capscrew) can be inserted between the bracket and the depth setting tube welded to the frame.
2. Move the ground following lever (Fig. 54) to the “H” setting (deepest).
3. Disconnect the out-board ball switch (Fig. 54) from the wire harness (Head-Low switch).
4. Loosen the jam nuts (LH & RH) on the depth adjustment tie rod (Fig. 54) .
5. Use a multi-meter to determine electrical closure of the ball switch.
6. Rotate the tie rod until the ball switch just closes or makes contact.
7. Secure the LH & RH jam nuts on the tie rod.
8. Re-connect the ball switch to the wire harness.

9. Remove the “pin” from the turf guard bracket and depth setting tube.

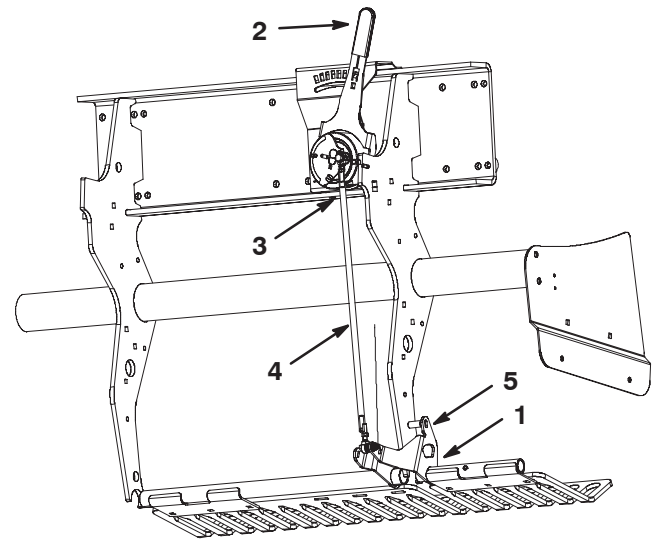

Figure 54

- | | |
|--------------------------------|-----------------------------|
| 1. Turf guard mounting bracket | 3. Out board ball switch |
| 2. Ground following lever | 4. Depth adjustment tie rod |
| | 5. Locking pin |

Inspecting Belts

The drive belts on the ProCore 648 have been designed to be very durable. However, the normal exposure to UV radiation, ozone or incidental exposure to chemicals can deteriorate the rubber compounding over time and lead to premature wear or material loss (i.e. chunking).

Annual belt inspection is highly recommended for signs of wear, excessive cushion cracks, or large embedded debris with replacement when needed.

A complete belt service kit is available from your Authorized Toro Distributor.

Side Shield Adjustment

The coring head side shields should be adjusted so the bottom rides between 1 to 1.5 inches from the turf while aerating.

1. Loosen the bolts and nuts securing the side shield to frame (Fig. 55).
2. Adjust shield up or down and tighten nuts.

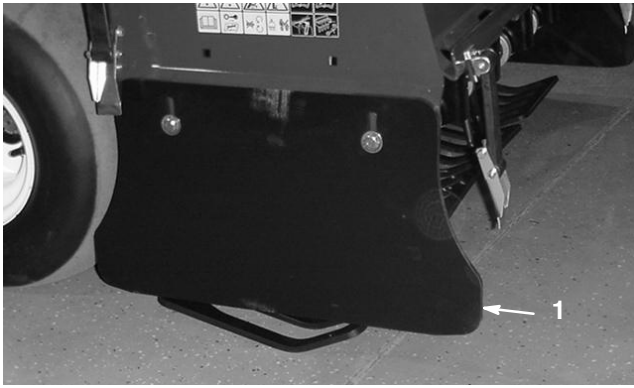

Figure 55

1. Side shield

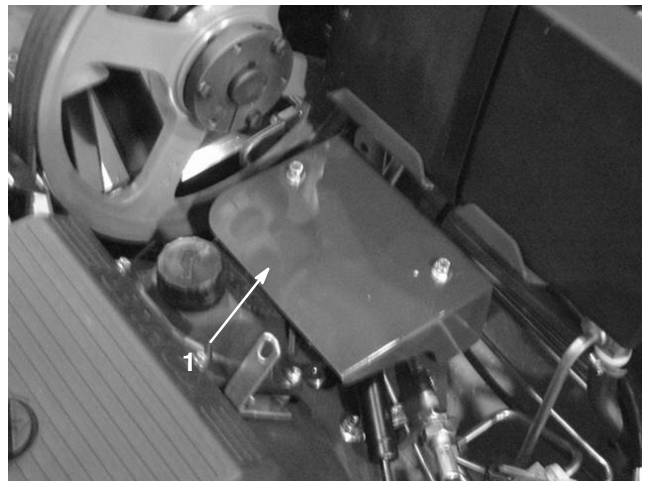

Figure 57

1. Pump shield

Adjusting Pump Belt

After the initial, eight (8) hours of use, re-adjust the belt tension on the pump drive belt.

1. Unlatch and remove the belt cover (Fig. 56).



Figure 56

1. belt cover

2. Remove the (2) pump shield mounting nuts and remove shield (Fig. 57).

3. Loosen the pump belt idler bolt just enough to allow movement within it's adjustment slot (Fig. 58).

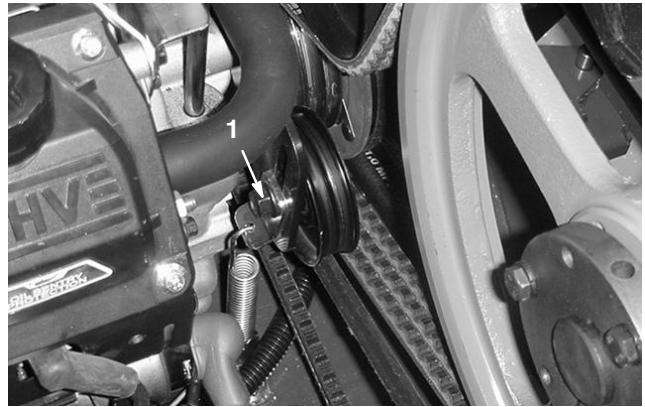

Figure 58

1. Idler bolt
2. Idler pulley

4. Tap the top of the idler pulley and allow its tensioning spring to adjust the belt tension.

Note: Do not apply more belt tension than the tensioning spring allows as damage to the components may result.

5. Secure the belt idler bolt.
6. Re-install pump shield and belt cover.

Replacing the Turf Guards

All turf guards should be replaced if broken or worn to less than 1/4 inch thickness. Broken turf guards can catch and tear turf creating undesirable damage.

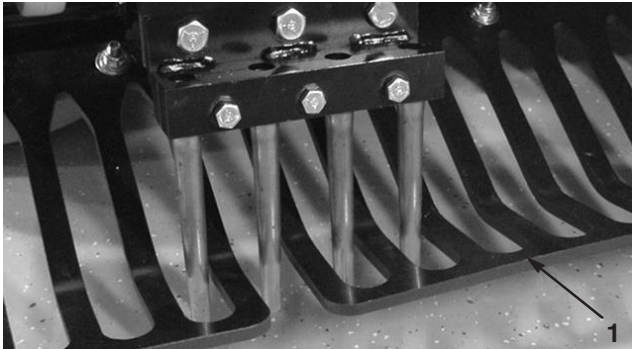

Figure 59

1. Turf guard

Thin turf guards can cause the True Core ground following system to be off from the desired depth setting due to both wear and the loss of stiffness.

Adjusting Hole Spacing

The hole spacing of the ProCore 648 is determined by the ground speed the traction system is set to maintain. The hole spacing is set to within 1/8" of the nominal setting at the factory.

In the event the hole spacing is off from the nominal setting more than desired, proceed as follows:

1. Unlatch and remove the belt cover (Fig. 56).
2. Remove the (2) pump shield mounting nuts and remove shield (Fig. 57).
3. In an open space that is free to aerate (i.e. sample plot), set hole spacing lever to desired hole spacing and make an aeration pass of at least 15 feet.
4. Measure the distance between several holes and divide by the number of holes measured to get your average hole spacing.

Example: Nominal Hole Spacing Setting of 2 inches

21.2 divided by 10 is 2.12, hole spacing is long by .12 inch from nominal (Fig. 60).



Figure 60

18.8 divided by 10 is 1.88, hole spacing is short by .12 inch from nominal (Fig. 61).



Figure 61

5. If an adjustment is needed, turn the pump stop bolt (Fig. 62) closer to the stop plate to decrease hole spacing or turn stop bolt away from stop plate to increase hole spacing.



Figure 62

1. Pump stop bolt

6. Repeat steps 3–5 until spacing is at the nominal setting.

Note: One complete turn of the stop bolt, adjusts the hole spacing approximately 5/8 inch.

Check Torque of Coring Head Fasteners

After the initial, eight (8) hours of use, check the coring head fasteners to ensure proper torque is maintained. Fastener torque requirements are listed on the reference service decal located on the coring head.

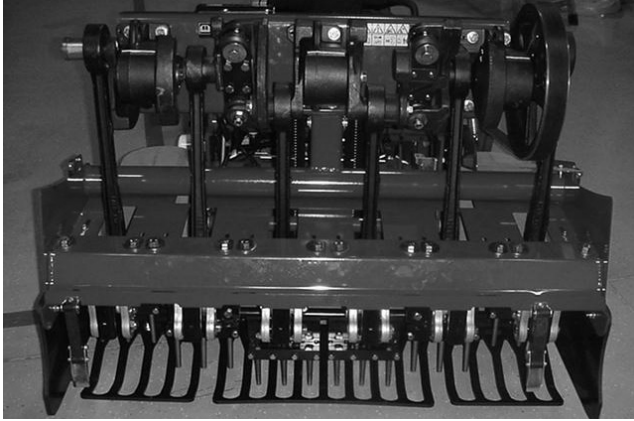

Figure 63

Coring Head Timing

The coring head timing marks are easily identified by the marks in the casting.

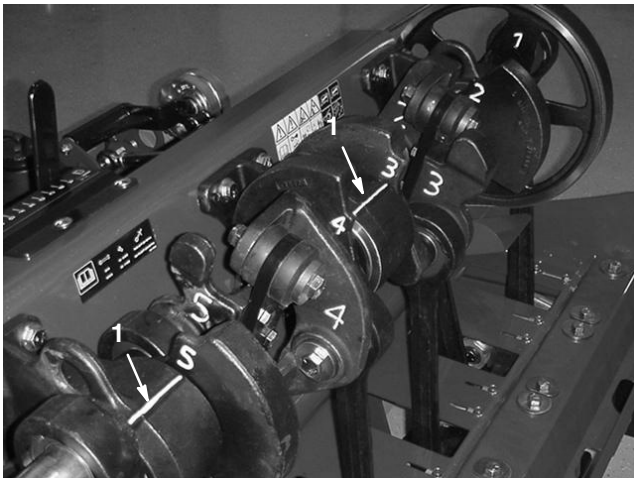

Figure 64

1. Timing marks

Servicing the Fuses

The electrical system is protected by fuses (Fig. 65). It requires no maintenance, however, if a fuse blows check component/circuit for malfunction or short.

1. To replace fuses pull out on the fuse to remove it.
2. Install a new fuse.



Figure 65

1. Fuses

Servicing the Battery



Warning



CALIFORNIA



Proposition 65 Warning

Battery posts, terminals, and related accessories contain lead and lead compounds, chemicals known to the State of California to cause cancer and reproductive harm. Wash hands after handling.

The battery electrolyte level must be properly maintained and the top of the battery kept clean. If the machine is stored in a location where temperatures are extremely high, the battery will run down more rapidly than if the machine is stored in a location where temperatures are cool.

Check the electrolyte level every 25 operating hours or, if the machine is in storage, every 30 days.

Maintain the cell level with distilled or demineralized water. Do not fill the cells above the bottom of the split ring inside each cell.

 **Danger** 



Battery electrolyte contains sulfuric acid which is a deadly poison and causes severe burns.

- **Do not drink electrolyte and avoid contact with skin, eyes or clothing. Wear safety glasses to shield your eyes and rubber gloves to protect your hands.**
- **Fill the battery where clean water is always available for flushing the skin.**

Keep the top of the battery clean by washing it periodically with a brush dipped in ammonia or bicarbonate of soda solution. Flush the top surface with water after cleaning it. Do not remove the fill caps while cleaning the battery.



The battery cables must be tight on the terminals to provide good electrical contact.

If corrosion occurs at the terminals, disconnect the cables, negative (-) cable first, and scrape the clamps and terminals separately. Reconnect the cables, positive (+) cable first, and coat the terminals with petroleum jelly.

 **Warning** 

Battery terminals or metal tools could short against metal tractor components causing sparks. Sparks can cause the battery gasses to explode, resulting in personal injury.

- **When removing or installing the battery, do not allow the battery terminals to touch any metal parts of the tractor.**
- **Do not allow metal tools to short between the battery terminals and metal parts of the tractor.**

 **Warning** 

Incorrect battery cable routing could damage the tractor and cables causing sparks. Sparks can cause the battery gasses to explode, resulting in personal injury.

- **Always *disconnect* the negative (black) battery cable before disconnecting the positive (red) cable.**
- **Always *connect* the positive (red) battery cable before connecting the negative (black) cable.**

Storing the Battery

If the machine will be stored more than 30 days, remove the battery and charge it fully. Either store it on the shelf or on the machine. Leave the cables disconnected if it is stored on the machine. Store the battery in a cool atmosphere to avoid quick deterioration of the charge in the battery. To prevent the battery from freezing, make sure it is fully charged. The specific gravity of a fully charged battery is 1.265–1.299.

Troubleshooting

PROBLEM	POSSIBLE CAUSES	CORRECTIVE ACTION
Starter does not crank	<ol style="list-style-type: none"> 1. Battery is dead. 2. Electrical connections are corroded or loose. 3. Relay or switch is defective. 4. Traction lever not in neutral position. 5. Neutral switch incorrectly adjusted. 	<ol style="list-style-type: none"> 1. Charge the battery. 2. Check electrical connections for good contact. 3. Contact Authorized Service Distributor. 4. Move traction lever to neutral position 5. Adjust neutral switch
Engine will not start, starts hard, or fails to keep running.	<ol style="list-style-type: none"> 1. Fuel tank is empty. 2. Choke is not on. 3. Air cleaner is dirty. 4. Spark plug wires are loose or disconnected. 5. Spark plugs are pitted, fouled, or gap is incorrect. 6. Dirt in fuel filter. 7. Dirt, water, or stale fuel is in fuel system. 	<ol style="list-style-type: none"> 1. Fill fuel tank with gasoline. 2. Move choke lever fully forward. 3. Clean or replace air cleaner element. 4. Install wires on spark plugs. 5. Install new, correctly gapped spark plugs. 6. Replace fuel filter. 7. Contact Authorized Service Distributor.
Engine loses power.	<ol style="list-style-type: none"> 1. Engine load is excessive. 2. Air cleaner is dirty. 3. Oil level in crankcase is low. 4. Cooling fins and air passages under engine blower housing are plugged. 5. Spark plugs are pitted, fouled, or gap is incorrect. 6. Dirt in fuel filter. 7. Dirt, water, or stale fuel is in fuel system. 	<ol style="list-style-type: none"> 1. Reduce ground speed. 2. Clean air cleaner element. 3. Add oil to crankcase. 4. Remove obstruction from cooling fins and air passages. 5. Install new, correctly gapped spark plugs. 6. Replace fuel filter. 7. Contact Authorized Service Distributor.
Engine overheats.	<ol style="list-style-type: none"> 1. Engine load is excessive. 2. Oil level in crankcase is low. 3. Cooling fins and air passages under engine blower housing are plugged. 	<ol style="list-style-type: none"> 1. Reduce ground speed. 2. Add oil to crankcase. 3. Remove obstruction from cooling fins and air passages.

PROBLEM	POSSIBLE CAUSES	CORRECTIVE ACTION
Abnormal vibration.	<ol style="list-style-type: none"> 1. Engine mounting bolts are loose. 2. Jackshaft or coring head bearings worn. 3. Jackshaft or coring head components loose or worn 	<ol style="list-style-type: none"> 1. Tighten engine mounting bolts. 2. Replace bearings. 3. Tighten or replace components.
Aerator does not drive.	<ol style="list-style-type: none"> 1. The parking brake is on. 2. Hydraulic fluid level low. 3. The tow valve is open. 4. Hydraulic system is damaged. 	<ol style="list-style-type: none"> 1. Release the parking brake. 2. Add hydraulic fluid. 3. Close the tow valve. 4. Contact your Toro Distributor.
Coring head does not drive.	<ol style="list-style-type: none"> 1. Worn clutch. 2. Worn switch or relay. 3. Worn or loose belts. 4. Hydraulic fluid level low. 5. The tow valve is open. 6. Hydraulic system is damaged. 	<ol style="list-style-type: none"> 1. Replace clutch 2. Replace switch or relay. 3. Adjust or replace belts. 4. Add hydraulic fluid. 5. Close the tow valve 6. Contact your Toro Distributor.
Head bounces while aerating.	<ol style="list-style-type: none"> 1. Ground is too hard. 2. Relief setting/Restriction orifice. 	<ol style="list-style-type: none"> 1. Refer to the operating tips on page 26. 2. Dynamic response of lift system. Adjust the system pressures. Refer to the Service Manual.
Turf tufting/tearing on entrance and exit.	<ol style="list-style-type: none"> 1. Mis-adjusted switch bundle. 2. Clutch wear/slippage 	<ol style="list-style-type: none"> 1. Adjust the #3 switch. Refer to the operating tips on page 26. 2. Contact your Toro Distributor for testing.
Turf tufting/tearing on entrance.	<ol style="list-style-type: none"> 1. Mis-adjusted switch bundle. 2. Head lowers too slowly. 	<ol style="list-style-type: none"> 1. Adjust the switch. Refer to the Service Manual. 2. Check the function of the SVQ solenoid.
Quad (or mini) tine hole spacing.	<ol style="list-style-type: none"> 1. Holes not evenly spaced. 	<ol style="list-style-type: none"> 1. Check the spacing. Refer to the operating tips on page 26.
Hole tufting with side eject tines.	<ol style="list-style-type: none"> 1. Ejection window catching on exit. 	<ol style="list-style-type: none"> 1. Rotate the tine 45–90° so it ejects out the side. 2. Try a hollow tine.

PROBLEM	POSSIBLE CAUSES	CORRECTIVE ACTION
Turf lifting/tearing while aerating	<ol style="list-style-type: none"> 1. Check coring head attitude 2. Improper tine selection. 3. Excessive depth. 4. Hole spacing too close. 5. Turf conditions (i.e. root structure insufficient to resist damage). 	<ol style="list-style-type: none"> 1. Refer to the Service Manual for specification. 2. Reduce the tine diameter, reduce the tine diameter, reduce the number of tines per head or increase the hole spacing. 3. Reduce the depth. 4. Increase the hole spacing. 5. Alter the aeration methods or timing.
Front of the hole is dimpled or pushed.	<ol style="list-style-type: none"> 1. Roto-Link in the "soft" position. 	<ol style="list-style-type: none"> 1. See operating tips on page 27.

Wiring Schematic

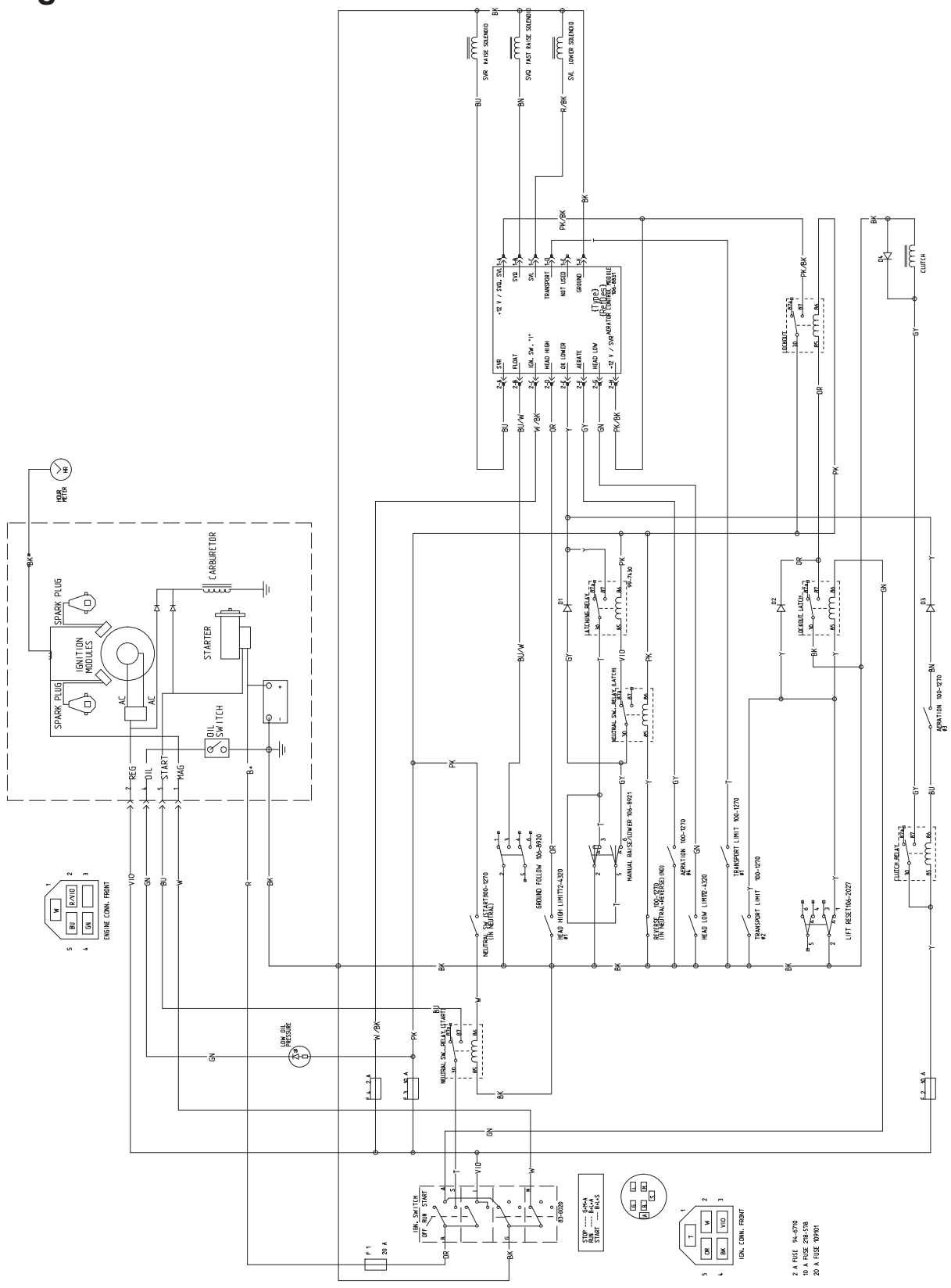

Hydraulic Schematic

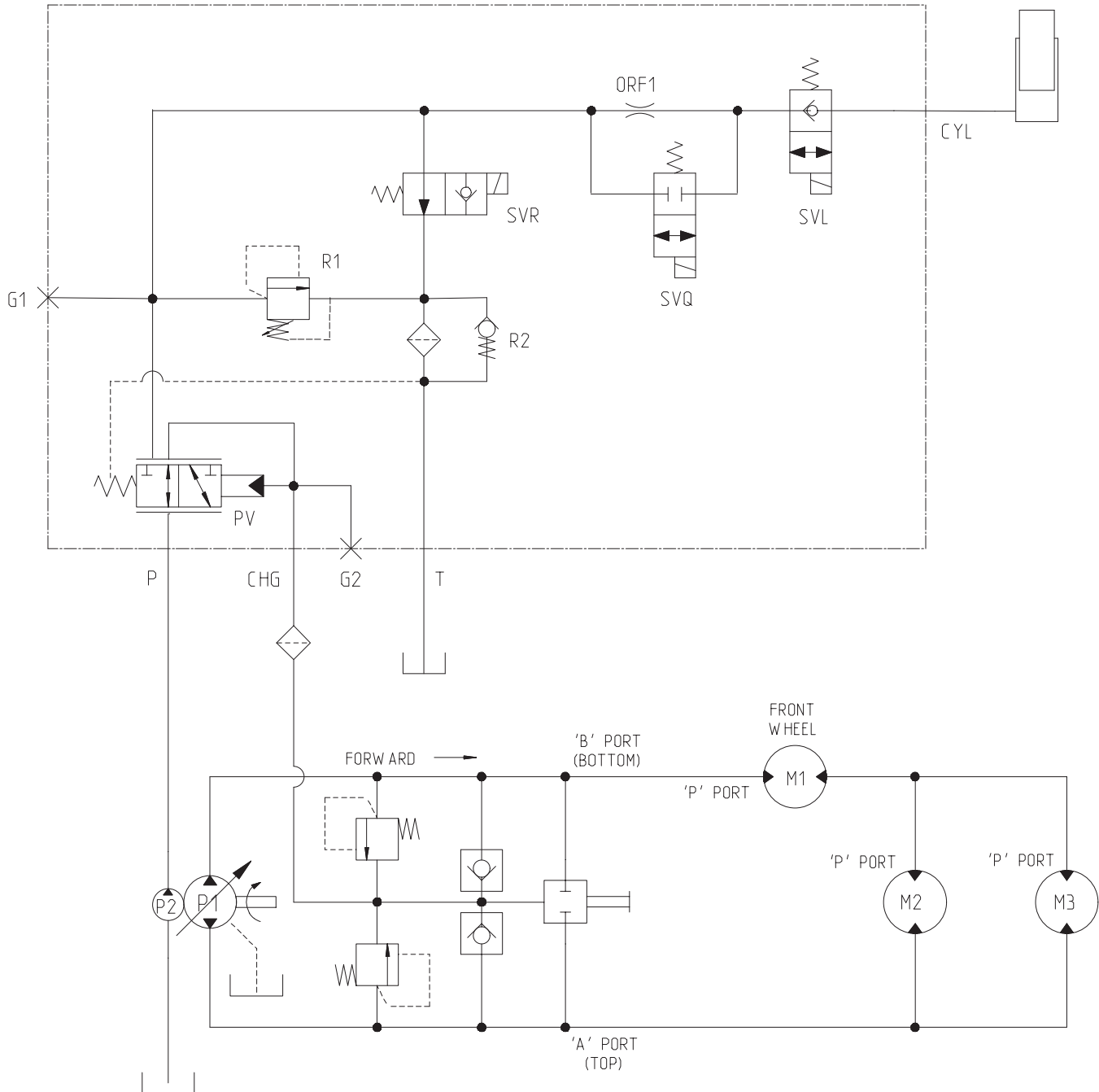

COMPONENT	C I R	GPM	PSI
P1	.98	10.5	2900
P2	.37	4.1	-
PV	-	-	40
R1	-	-	1000
R2	-	-	40
M1	23.8	-	-
M2	12.1	-	-
M3	12.1	-	-
ORF1	∅.050	-	-

Cleaning and Storage

1. Set the parking brake and turn the ignition key to off. Remove spark plug wire. Remove the key.
2. Remove grass, dirt, and grime from the external parts of the entire machine, especially the engine and hydraulic system. Clean dirt and chaff from the outside of the engine's cylinder head fins and blower housing.

Important You can wash the machine with mild detergent and water. Do not pressure wash the machine. Avoid excessive use of water, especially near the control panel, engine, hydraulic pumps and motors.

3. Service the air cleaner; refer to Servicing the Air Cleaner.
4. Change the crankcase oil; refer to Servicing the Engine Oil.
5. Change the hydraulic filter; refer to Servicing the Hydraulic System.
6. Check the tire pressure; refer to Checking the Tire Pressure.
7. Charge the battery; refer to Servicing the Battery.

Note: Run the machine with the engine at high idle for 2 to 5 minutes after washing.

8. Check the condition of the tines. Refer to Servicing the Tines.
9. Prepare the machine for storage when non-use occurs over 30 days. Prepare machine for storage as follows.
 - A. Add a petroleum based stabilizer/conditioner to fuel in the tank. Follow mixing instructions from stabilizer manufacture. **Do not use an alcohol based stabilizer (ethanol or methanol).**

Note: A fuel stabilizer/conditioner is most effective when mixed with fresh gasoline and used at all times.

- B. Run engine to distribute conditioned fuel through the fuel system (5 minutes).
- C. Stop engine, allow to cool and drain the fuel tank; refer to Servicing the Fuel Tank.
- D. Restart engine and run it until it stops.
- E. Choke the engine. Start and run engine until it will not start.
- F. Dispose of fuel properly. Recycle as per local codes.

Important Do not store stabilizer/conditioned gasoline over 90 days.

10. Remove the spark plugs and check the condition; refer to Servicing the Spark Plugs. With the spark plugs removed from the engine, pour two tablespoons of engine oil into each spark plug hole. Now use the starter to crank the engine and distribute the oil inside the cylinders. Install the spark plugs. Do not install the wires on the spark plugs.
11. Check and tighten all bolts, nuts, and screws. Repair or replace any part that is damaged or defective.
12. Wash and dry entire unit. Remove tines, clean and oil. Spray light oil mist on coring head bearings (crank & damper links).
13. Paint all scratched or bare metal surfaces. Paint is available from your Authorized Service Distributor.
14. Store the machine in a clean, dry garage or storage area. Remove the key from the ignition switch and keep it out of reach of children or other unauthorized users.
15. Secure service latch if the aerator is to be stored for more than a couple days.
16. Cover the machine to protect it and keep it clean.

Notes



Evaporative Emission Control Warranty Statement
California Evaporative Emission Control Warranty Statement
Your Warranty Rights and Obligations

Introduction

The California Air Resources Board and The Toro® Company are pleased to explain the evaporative emission control system's warranty on your 2006 model year equipment. In California, new equipment that use small off-road engines must be designed, built, and equipped to meet the State's stringent anti-smog standards. The Toro Company must warrant the evaporative emission control system on your equipment for two years provided there has been no abuse, neglect or improper maintenance of your equipment. Your evaporative emission control system may include parts such as: fuel lines, fuel line fittings, and clamps.

Manufacturer's Warranty Coverage:

This evaporative emission control system is warranted for two years. If any evaporative emission-related part on your equipment is defective, the part will be repaired or replaced by The Toro® Company.

Owner's Warranty Responsibilities:

- As the equipment owner, you are responsible for performance of the required maintenance listed in your Operator's Manual. The Toro® Company recommends that you retain all receipts covering maintenance on your equipment, but The Toro® Company cannot deny warranty solely for the lack of receipts.
- As the equipment owner, you should however be aware that The Toro® Company may deny you warranty coverage if your emission warranty parts have failed due to abuse, neglect, or improper maintenance or unapproved modifications.
- You are responsible for presenting your equipment to an Authorized Service Dealer as soon as the problem exists. The warranty repairs should be completed in a reasonable amount of time, not to exceed 30 days. If you have a question regarding your warranty coverage, you should contact The Toro® Company at 1-952-948-4027 or call us toll free at the number listed in your Toro Warranty statement.

Defects Warranty Requirements:

1. The warranty period begins on the date the engine or equipment is delivered to an ultimate purchaser.
2. General Evaporative Emissions Warranty Coverage. The emission warranty parts must be warranted to the ultimate purchaser and any subsequent owner that the evaporative emission control system when installed was
 - A. Designed, built, and equipped so as to conform with all applicable regulations; and
 - B. Free from defects in materials and workmanship that causes the failure of a warranted part for a period of two years.
3. The warranty on evaporative emissions-related parts will be interpreted as follows:
 - A. Any warranted part that is not scheduled for replacement as required maintenance in the written instructions must be warranted for the warranty period of two years. If any such part fails during the period of warranty coverage, it must be repaired or replaced by The Toro® Company. Any such part repaired or replaced under the warranty must be warranted for a time not less than the remaining warranty period.
 - B. Any warranted part that is scheduled only for regular inspection in the written instructions must be warranted for the warranty period of two years. A statement in such written instructions to the effect of "repair or replace as necessary" will not reduce the period of warranty coverage. Any such part repaired or replaced under warranty must be warranted for a time not less than the remaining warranty period.
 - C. Any warranted part that is scheduled for replacement as required maintenance in the written instructions must be warranted for the period of time prior to the first scheduled replacement point for that part. If the part fails prior to the first scheduled replacement, the part must be repaired or replaced by The Toro® Company. Any such part repaired or replaced under warranty must be warranted for a time not less than the remainder of the period prior to the first scheduled replacement point for the part.
 - D. Repair or replacement of any warranted part under the warranty provisions of this article must be performed at no charge to the owner at an Authorized Service Dealer.
 - E. Notwithstanding the provisions of subsection (D) above, warranty services or repairs must be provided at an Authorized Service Dealer.
 - F. The owner must not be charged for diagnostic labor that leads to the determination that a warranted part is in fact defective, provided that such diagnostic work is performed at an Authorized Service Dealer.
 - G. Throughout the evaporative emission control system's two year warranty period, The Toro® Company must maintain a supply of warranted parts sufficient to meet the expected demand for such parts.
 - H. Manufacturer approved replacement parts must be used in the performance of any warranty maintenance or repairs and must be provided without charge to the owner. Such use will not reduce the warranty obligations of The Toro® Company.
 - I. The use of any add-on or modified parts will be grounds for disallowing a warranty claim made in accordance with this article. The Toro® Company will not be liable under this Article to warrant failures of warranted parts caused by the use of an add-on or modified part.
 - J. The Toro® Company shall provide any documents that describe the warranty procedures or policies within five working days of request by the Air Resources Board.

Emission Warranty Parts List:

The following list includes the parts covered under this warranty:

- Fuel Lines
- Fuel Line Fittings
- Clamps



The Toro Aerator Commercial Products Warranty

A Two-Year Limited Warranty

Conditions and Products Covered

The Toro Company and its affiliate, Toro Warranty Company, pursuant to an agreement between them, jointly warrant your Toro Hydroject® 3000, Hydroject® 4000, Greens, Fairway Aerator or ProCore® Aerator ("Product") to be free from defects in materials or workmanship for two years or 500 operational hours*, whichever occurs first. Where a warrantable condition exists, we will repair the Product at no cost to you including diagnosis, labor, parts, and transportation. This warranty begins on the date the Product is delivered to the original retail purchaser.

* Product equipped with hour meter

Instructions for Obtaining Warranty Service

You are responsible for notifying the Commercial Products Distributor or Authorized Commercial Products Dealer from whom you purchased the Product as soon as you believe a warrantable condition exists.

If you need help locating a Commercial Products Distributor or Authorized Dealer, or if you have questions regarding your warranty rights or responsibilities, you may contact us at:

Toro Commercial Products Service Department
Toro Warranty Company
8111 Lyndale Avenue South
Bloomington, MN 55420-1196
952-888-8801 or 800-982-2740
E-mail: commercial.service@toro.com

Owner Responsibilities

As the Product owner, you are responsible for required maintenance and adjustments stated in your operator's manual. Failure to perform required maintenance and adjustments can be grounds for disallowing a warranty claim.

Items and Conditions Not Covered

Not all product failures or malfunctions that occur during the warranty period are defects in materials or workmanship. This express warranty does not cover the following:

- Product failures which result from the use of non-Toro replacement parts, or from installation and use of add-on, modified, or unapproved accessories
- Product failures which result from failure to perform required maintenance and/or adjustments
- Product failures which result from operating the Product in an abusive, negligent or reckless manner
- Parts subject to consumption through use unless found to be defective. Examples of parts which are consumed, or used up, during normal Product operation include, but are not limited to, blades, reels, bedknives, tines, spark plugs, castor wheels, tires, filters, belts, etc.

Countries Other than the United States or Canada

Customers who have purchased Toro products exported from the United States or Canada should contact their Toro Distributor (Dealer) to obtain guarantee policies for your country, province, or state. If for any reason you are dissatisfied with your Distributor's service or have difficulty obtaining guarantee information, contact the Toro importer. If all other remedies fail, you may contact us at Toro Warranty Company.

- Failures caused by outside influence. Items considered to be outside influence include, but are not limited to, weather, storage practices, contamination, use of unapproved coolants, lubricants, additives, or chemicals, etc.
- Normal "wear and tear" items. Normal "wear and tear" includes, but is not limited to, damage to seats due to wear or abrasion, worn painted surfaces, scratched decals or windows, etc.

Parts

Parts scheduled for replacement as required maintenance are warranted for the period of time up to the scheduled replacement time for that part.

Parts replaced under this warranty become the property of Toro. Toro will make the final decision whether to repair any existing part or assembly or replace it. Toro may use factory remanufactured parts rather than new parts for some warranty repairs.

General Conditions

Repair by an Authorized Toro Distributor or Dealer is your sole remedy under this warranty.

Neither The Toro Company nor Toro Warranty Company is liable for indirect, incidental or consequential damages in connection with the use of the Toro Products covered by this warranty, including any cost or expense of providing substitute equipment or service during reasonable periods of malfunction or non-use pending completion of repairs under this warranty. Except for the Emissions warranty referenced below, if applicable, there is no other express warranty. All implied warranties of merchantability and fitness for use are limited to the duration of this express warranty.

Some states do not allow exclusions of incidental or consequential damages, or limitations on how long an implied warranty lasts, so the above exclusions and limitations may not apply to you.

This warranty gives you specific legal rights, and you may also have other rights which vary from state to state.

Note regarding engine warranty: The Emissions Control System on your Product may be covered by a separate warranty meeting requirements established by the U.S. Environmental Protection Agency (EPA) and/or the California Air Resources Board (CARB). The hour limitations set forth above do not apply to the Emissions Control System Warranty. Refer to the Engine Emission Control Warranty Statement printed in your operator's manual or contained in the engine manufacturer's documentation for details.