

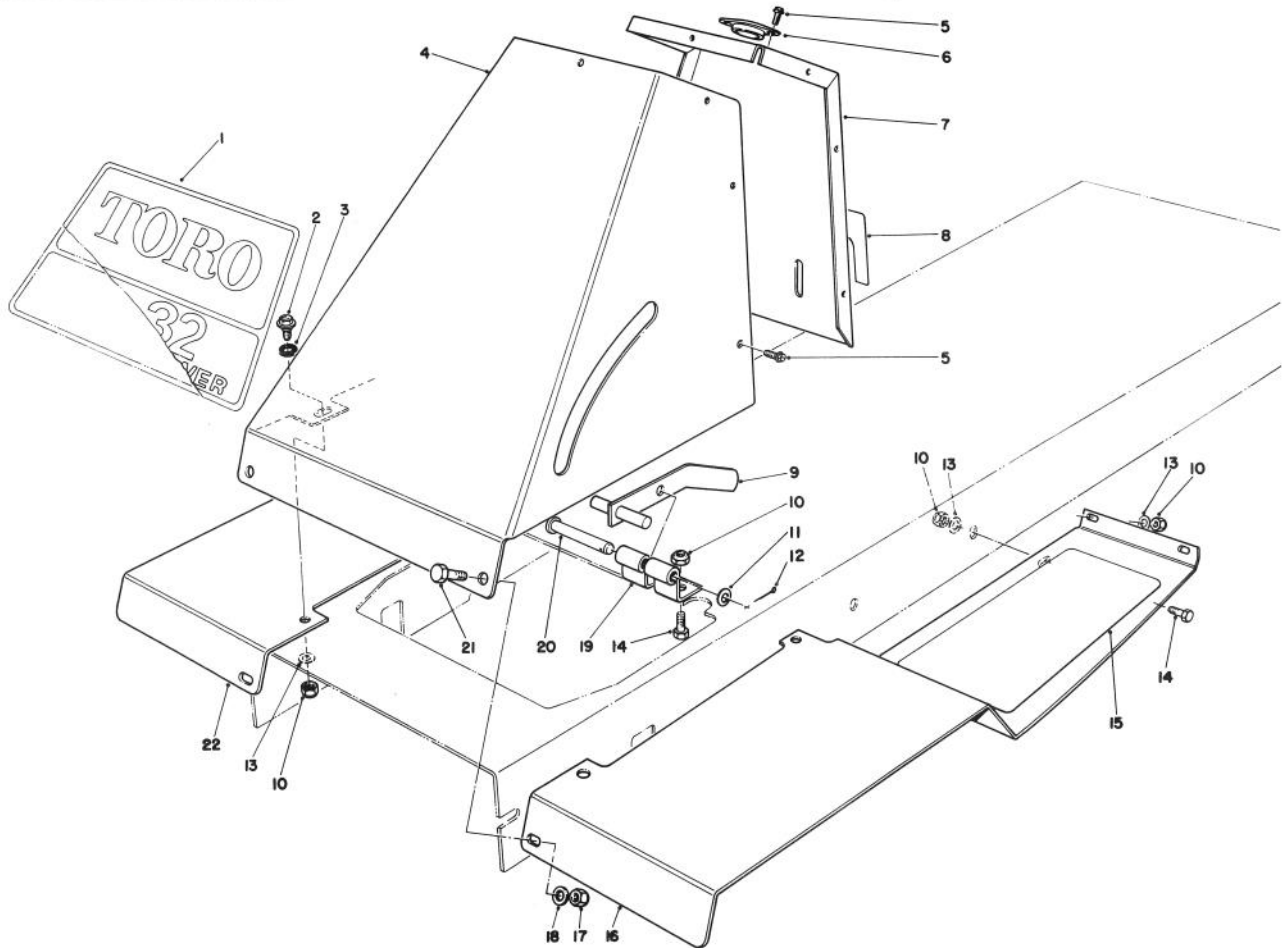

 MODEL NO. 56150-8000001 & UP  
 MODEL NO. 56175-8000001 & UP

**PARTS  
CATALOG**
**8 H.P. & 12 H.P. PROFESSIONAL  
REAR ENGINE RIDERS — ELECTRIC**

**FRONT TOWER ASSEMBLY**

Ref. No.	Part No.	Description	No. Used
1	56-7850	Decal — Toro 832	1
*	63-5550	Decal — Toro 1232	1
2	5-2490	Bolt — Shoulder	4
3	3-3287	Spacer — Rubber	4
4	56-7130	Tower — Front	1
5	32104-76	Screw — Self Tap Acorn Head	9
6	56-7170	Guide — Steering Shaft	1
7	56-7140	Tower — Rear	1
8	56-7810	Decal — Parking Brake	1
9	47-1290	Parking Brake	1
10	3296-29	Nut — Lock	14
11	3256-24	Washer — Flat Plain	1

Ref. No.	Part No.	Description	No. Used
12	3272-6	Cotter Pin	1
13	3256-23	Washer — Flat	12
14	322-3	Capscrew	6
15	47-1440	Tread — Foot	2
16	47-0940	Footrest — L.H.	1
17	32152-4	Nut — Lock	2
18	3256-22	Washer — Plain	2
19	47-2060	Bracket — Parking Brake	1
20	283-52	Clevis Pin	1
21	321-3	Capscrew	2
22	47-0930	Footrest — R.H.	1

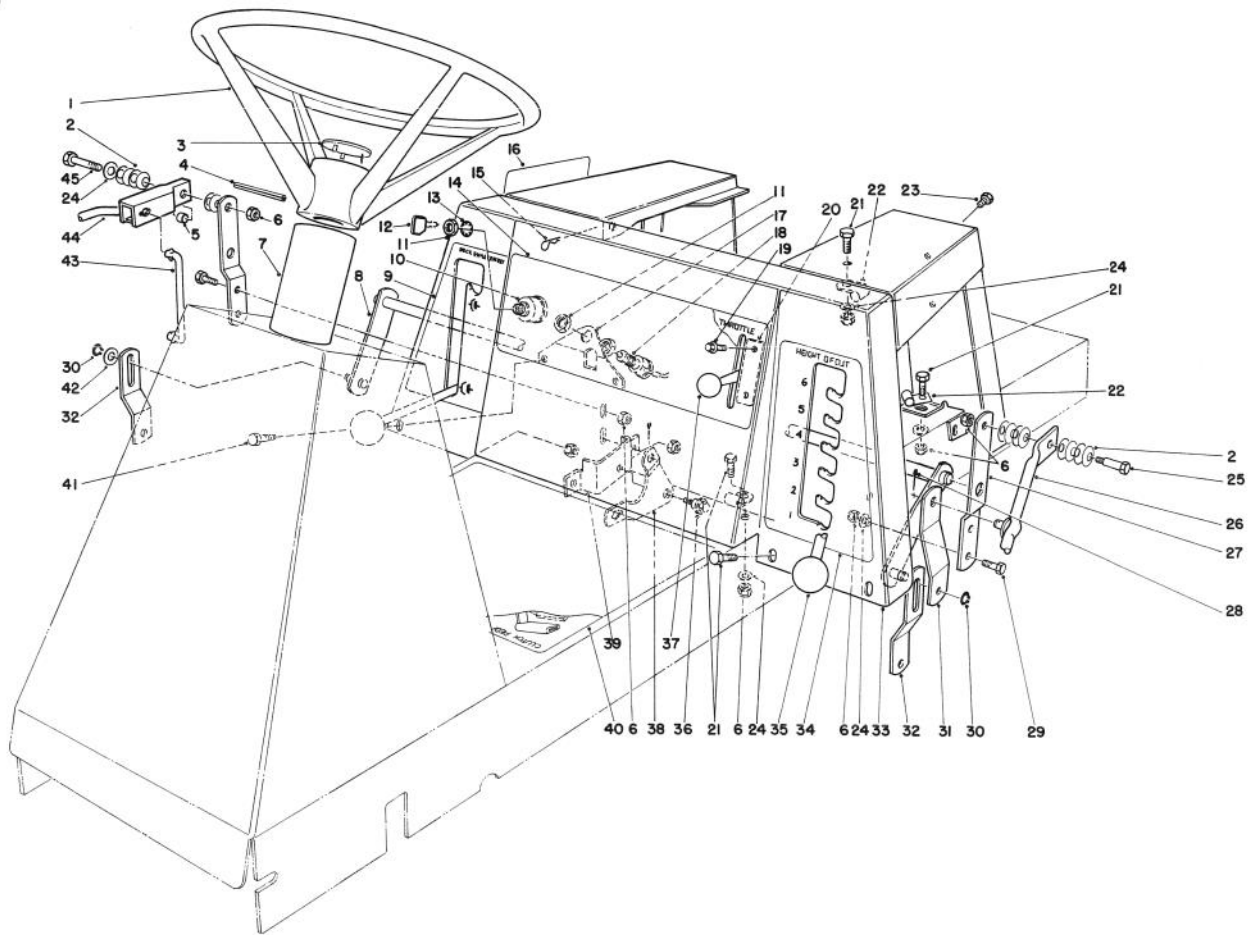
\* Not Illustrated



## STEERING WHEEL & LINKAGE ASSEMBLY

Ref. No.	Part No.	Description	No. Used
1	49-3240	Steering Wheel Assembly (Incl. Ref. #3)	1
2	3290-413	Washer — Belleville	14
3	47-2070	Insert — Steering Wheel	1
4	32121-78	Pin — Roll	1
5	61-4300	Spacer — Pivot	1
6	3296-29	Nut — Lock	10
7	47-1980	Cover — Steering Shaft	1
8	56-7400	Arm — Lever, Height of Cut	1
9	56-7840	Decal — Deck Engage	1
10	63-5630	Switch — Ignition (Incl. Ref. #11-13)	1
11	218-461	Nut — Lock	3
12	62-7770	Key	1
13	3254-5	Washer — Lock, Int. Tooth	1
14	56-7820	Decal — Ignition & Throttle	1
15	3290-307	Hairpin — Cotter	2
16	44-7260	Decal — Shift Pattern	1
17	56-7150	Bracket — Mounting, Switch	1
18	56-7640	Switch — Deck (Incl. Ref. #11)	1
19	32104-76	Screw — Self Tapping, Acorn Head	2
20	56-7220	Control — Throttle (Incl. Ref. #37)	1
21	322-4	Screw — Cap, Hex Hd.	5
22	2412-68	Clamp	3

Ref. No.	Part No.	Description	No. Used
23	321-3	Screw — Cap, Hex Hd.	2
24	3256-23	Washer — Flat	8
25	28-0540	Bolt — Shoulder	1
26	47-1850	Lever — Height of Cut	1
27	47-1840	Bracket — Height of Cut	1
28	3272-6	Pin — Cotter	2
29	322-5	Screw — Cap, Hex Hd.	5
30	32151-61	Ring — Retaining	2
31	56-7360	Bracket — Height of Cut Engagement	1
32	63-5830	Link — Deck Suspension	2
33	56-7300	Body — Seat	1
34	56-7830	Decal — Height of Cut	1
35	233-48	Knob	2
36	19-1470	Bolt — Shoulder	1
37	233-59	Knob	1
38	56-7540	Bell Crank — Deck Engage	1
39	56-7550	Bracket — Bell Crank Mounting	1
40	56-7800	Decal — Instructions	1
41	322-3	Screw — Cap, Hex Hd.	2
42	3256-26	Washer — Flat	1
43	56-7560	Link — Bell Crank	1
44	61-4250	Lift Arm Assembly	1
45	322-9	Screw — Cap, Hex Hd.	1

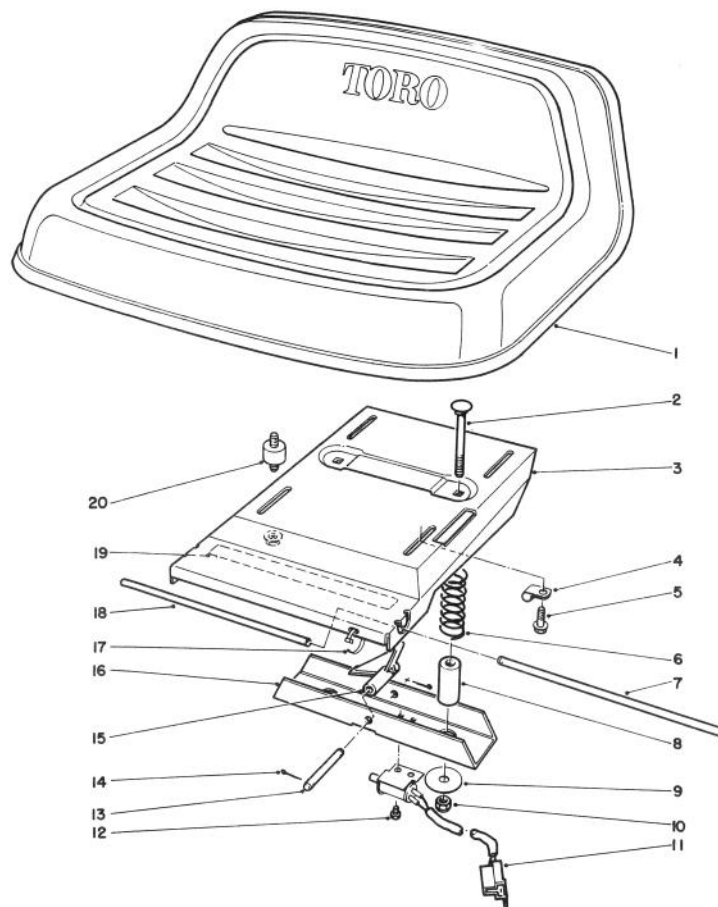

## SEAT ASSEMBLY

Ref. No.	Part No.	Description	No. Used
1	55-8690	Seat Assembly	1
2	3230-7	Bolt — Carriage	2
3	63-5540	Base — Seat	1
4	2412-68	Clamp — Wire	1
5	32128-20	Nut — Lock	4
6	63-5860	Spring — Compression	2
7	56-7210	Rod — Seat Base	1
8	63-5870	Spacer — Seat Switch	2
9	3256-57	Washer — Flat	2
10	3296-29	Nut — Lock	2

Ref. No.	Part No.	Description	No. Used
11	63-5840	Switch — Interlock, Seat	1
12	32144-1	Screw — Self Tapping	2
13	283-65	Pin — Clevis	1
14	3276-6	Pin — Cotter	2
15	63-5880	Lever — Switch, Seat	1
16	63-5850	Channel — Switch, Seat	1
17	3290-378	Tie — Cable	1
18	63-5670	Tube — Seat Rod Bumper	1
19	63-5890	Decal	1
20	62-5480	Isolator — Seat	4

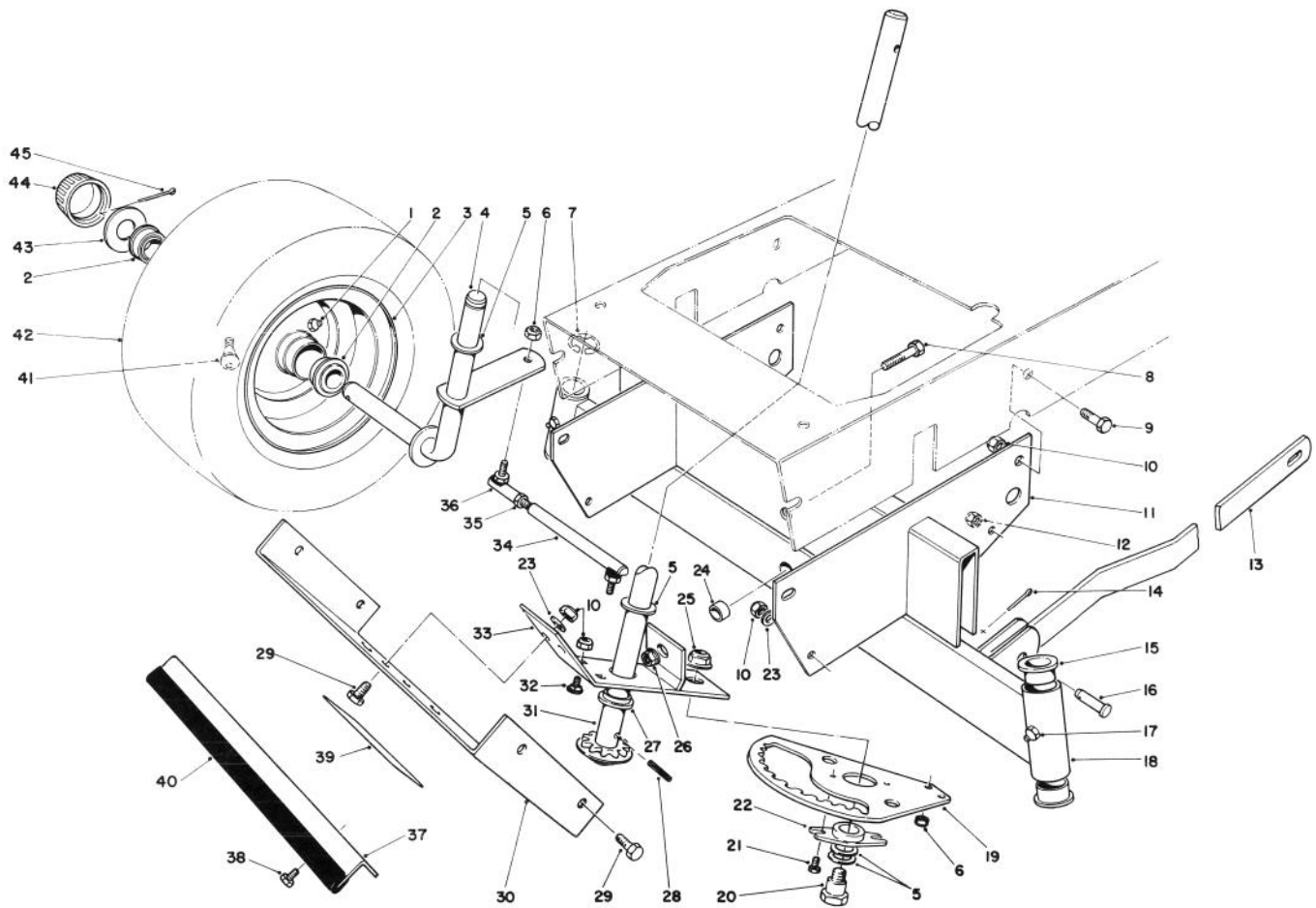

## FRONT AXLE ASSEMBLY

Ref. No.	Part No.	Description	No. Used
1	302-5	Grease Fitting	2
2	251-210	Bearing	4
3	217-80	Rim	2
4	47-0600	Spindle — R.H.	1
*	47-0590	Spindle — L.H.	1
5	3-6498	Washer — Thrust	5
6	3296-4	Nut — Lock	4
7	32151-48	Ring — Retaining External	2
8	325-6	Capscrew — Hex. Hd.	1
9	322-2	Capscrew — Hex. Hd.	2
10	3296-29	Nut — Lock	8
11	47-0760	Support — Front Axle	1
12	32152-4	Nut — Lock	1
13	47-0010	Arm — Front Deck Suspension	2
14	3272-6	Pin — Cotter	2
15	27-9080	Bearing — Flange	4
16	283-2	Pin — Clevis	2
17	302-49	Fitting — Grease	2
18	47-0980	Axle — Front (Incl. Ref. #15 & 17)	1
19	56-7510	Rack — Steering	1
20	56-7530	Bolt — Shoulder	1
21	12-3270	Screw — Special	2
22	56-7520	Bushing — Sector	1
23	3256-23	Washer — Plain	6

Ref. No.	Part No.	Description	No. Used
24	28-0380	Spacer — Front Axle	1
25	32128-21	Nut — Flange Lock	1
26	32128-23	Nut — Lock	1
27	47-0700	Bearing — Flange	1
28	32121-9	Pin — Roll	1
29	322-4	Capscrew — Hex. Hd.	6
30	56-7180	Cover — Front	1
31	56-7500	Shaft — Steering	1
32	3230-18	Bolt — Carriage	2
33	56-7470	Bracket — Steering Rack (Incl. Ref. #27)	1
34	47-0610	Tie Rod — Steering (Incl. Ref. #35 & 36)	2
35	3220-2	Nut — Hex. Jam	2
36	2411-32	Ball Joint	2
37	57-6010	Guard — Front	1
38	32144-11	Screw — Thread Forming	2
39	26-4830	Decal — Warning	1
40	57-6040	Trim — Front Guard	1
41	232-27	Valve Stem w/Cap	2
42	231-116	Tire	2
43	28-2480	Washer	2
44	61-9780	Hub Cap	2
45	3272-12	Pin — Cotter	2
†	232-44	Inner Tube	2

\* Not Illustrated

† Service Replacement Part

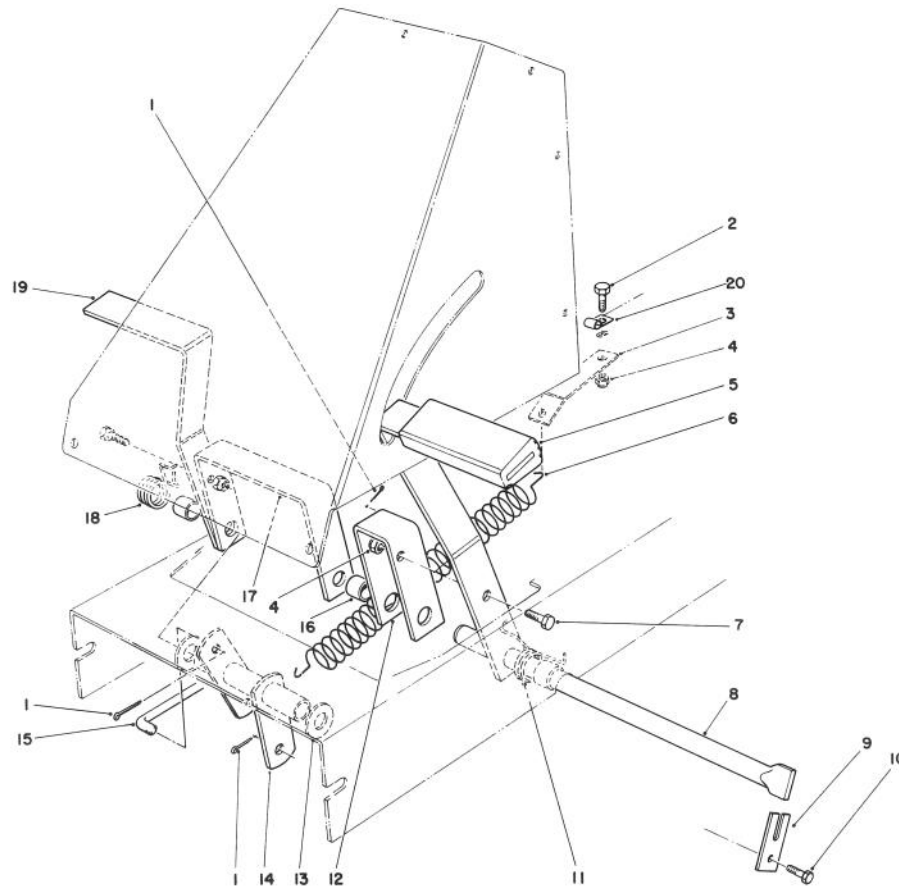

## BRAKE & CLUTCH ASSEMBLY

Ref. No.	Part No.	Description	No. Used
1	3272-6	Pin — Cotter	3
2	322-3	Screw — Cap, Hex Hd. (Used on Model No. 56145)	1
2	322-4	Screw — Cap, Hex Hd. (Used on Model No. 56138)	1
3	56-7240	Bracket — Spring Retaining	1
4	3296-29	Nut — Lock	3
5	65-2920	Pad — Foot Pedal	2
6	62-3930	Spring — Extension	1
7	322-5	Screw — Cap, Hex Hd.	2
8	47-0770	Shaft — Pedal Pivot	1
9	47-0780	Retainer — Shaft	1

Ref. No.	Part No.	Description	No. Used
10	321-3	Screw — Cap, Hex Hd.	1
11	56-7070	Spring — Torsion Clutch	1
12	47-0560	Bracket — Clutch Pedal	1
13	3256-27	Washer — Flat	2
14	56-7650	Tube — Pivot	1
15	56-7570	Rod — Engagement	1
16	47-0570	Spacer — Pedal	3
17	47-0550	Bracket — Pedal, Brake	1
18	56-7080	Spring — Brake, Torsion	1
19	47-0540	Pedal	2
20	2412-68	Clamp (Used on Model No. 56138 only)	1

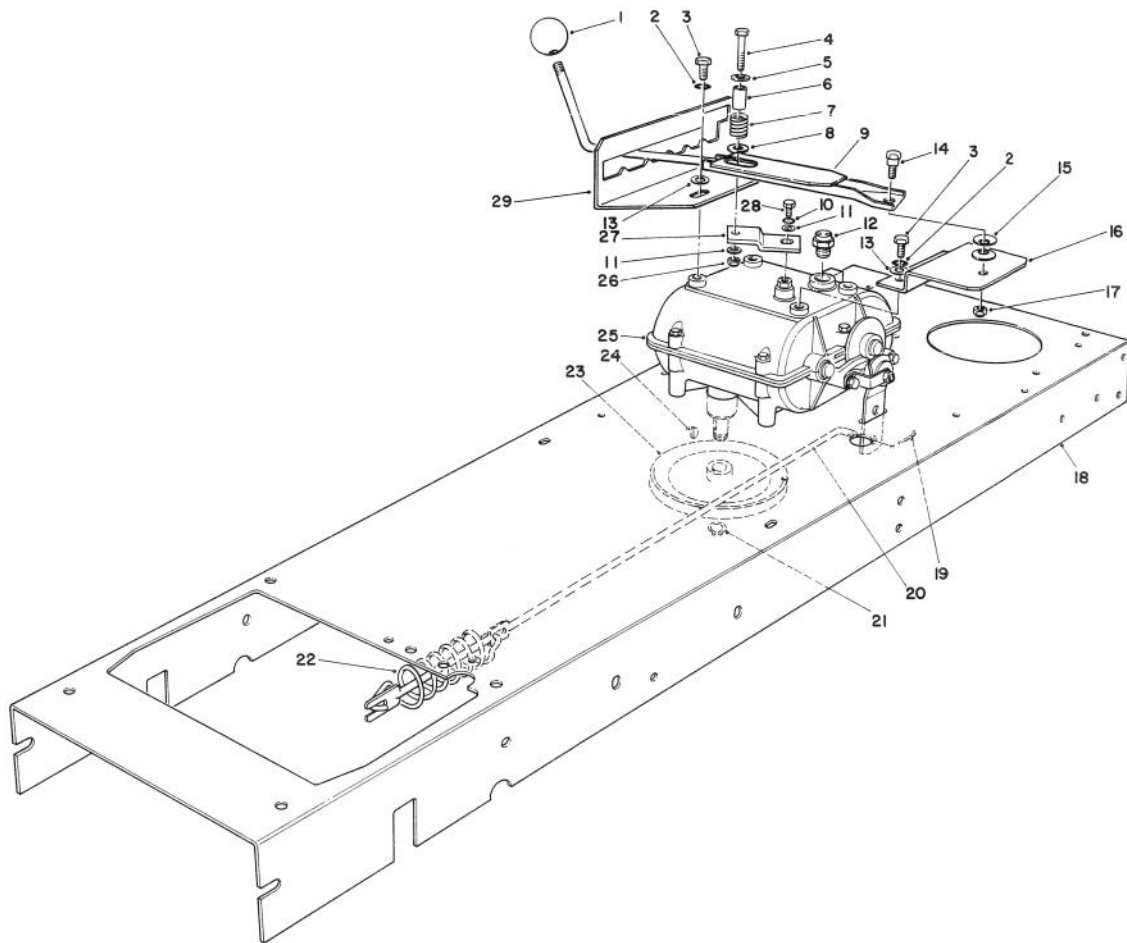

## TRANSMISSION LINKAGE ASSEMBLY

Ref. No.	Part No.	Description	No. Used
1	233-48	Knob	1
2	3253-4	Washer — Lock	4
3	32144-11	Screw — Thread Forming	4
4	321-15	Capscrew — Hex Hd.	1
5	3256-55	Washer — Fender	1
6	56-7740	Spacer — Split	1
7	56-7730	Spring — Compression	1
8	3256-4	Washer — Plain	1
9	56-7600	Lever — Shift	1
10	3253-3	Lockwasher	2
11	3256-22	Washer — Plain	2
12	28-4250	Switch — Neutral Start	1
13	3256-23	Washer — Flat	4
14	19-1470	Bolt — Shoulder	1
15	3290-413	Washer — Belleville	2

Ref. No.	Part No.	Description	No. Used
16	56-7610	Bracket — Shift Mounting	1
17	3296-29	Nut — Lock	1
18	56-7160	Frame — Main	1
19	3272-6	Pin — Cotter	1
20	56-7060	Rod — Brake	1
21	32120-64	Ring — Retaining External	1
22	57-9940	Spring — Brake	1
23	7-4085	Pulley — Transmission	1
24	3257-5	Key — Woodruff	1
25	47-1530	Transmission	1
26	32152-4	Nut — Lock	1
27	56-7620	Lever — Shift	1
28	329-4	Capscrew	1
29	56-7630	Gate — Shift	1

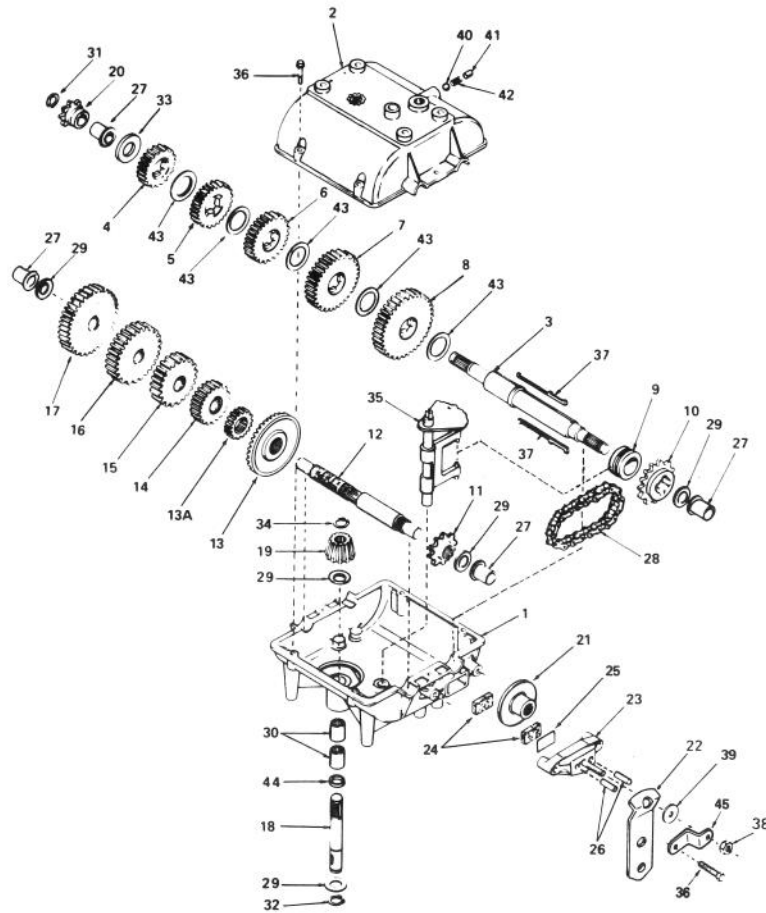

## TRANSMISSION MODEL 770A

Ref. No.	Part No.	Description	No. Used
1	770061	Case — Transmission	1
2	772083	Cover — Transmission	1
3	776161	Shaft — Output & Brake	1
4	778121A	Gear — Spur (20 teeth)	1
5	778122A	Gear — Spur (22 teeth)	1
6	778123A	Gear — Spur (25 teeth)	1
7	778124A	Gear — Spur (30 teeth)	1
8	778125	Gear — Spur (35 teeth)	1
9	784266	Collar — Shift	1
10	786083	Sprocket (18 teeth)	1
11	786082	Sprocket (9 teeth)	1
12	776134	Shaft — Counter	1
13	778137A	Gear — Bevel (42 teeth)	1
13A	778136	Gear — Spur (15 teeth)	1
14	778126A	Gear — Spur (20 teeth)	1
15	778127A	Gear — Spur (25 teeth)	1
16	778128A	Gear — Spur (28 teeth)	1
17	778129A	Gear — Spur (30 teeth)	1
18	776135	Shaft — Input	1
19	778113A	Bevel Pinion — Input	1
20	786048	Sprocket (8 teeth)	1
21	790003	Disk — Brake	1
22	790013	Lever — Brake	1
23	790025	Holder — Brake Pad	1

Ref. No.	Part No.	Description	No. Used
24	790006	Pad — Brake	1
25	790007	Plate — Brake Pad	1
26	786026	Pin — Dowel	1
27	780105A	Bushing — Flanged	1
28	786081	Chain Roller (No. 41 chain, 24 links)	1
29	780072	Race — Thrust	1
30	780086	Bearing — Needle	1
31	792072	Ring — Retaining	1
32	792035	Ring — Retaining	1
33	780109	Washer	1
34	788040	Ring — Retaining	1
35	784267	Rod & Fork Assy. — Shift	1
36	792073	Screw — Hex. Hd.	1
37	792089A	Key	1
38	792075	Nut — Lock	1
39	792076	Washer — Flat	1
40	792077	Ball — Steel	1
41	792078	Screw — Set	1
42	792079	Spring	1
43	780108	Washer — Thrust	1
44	792001	Ring — Square Cut	1
45	786086	Bracket — Brake Lever	1



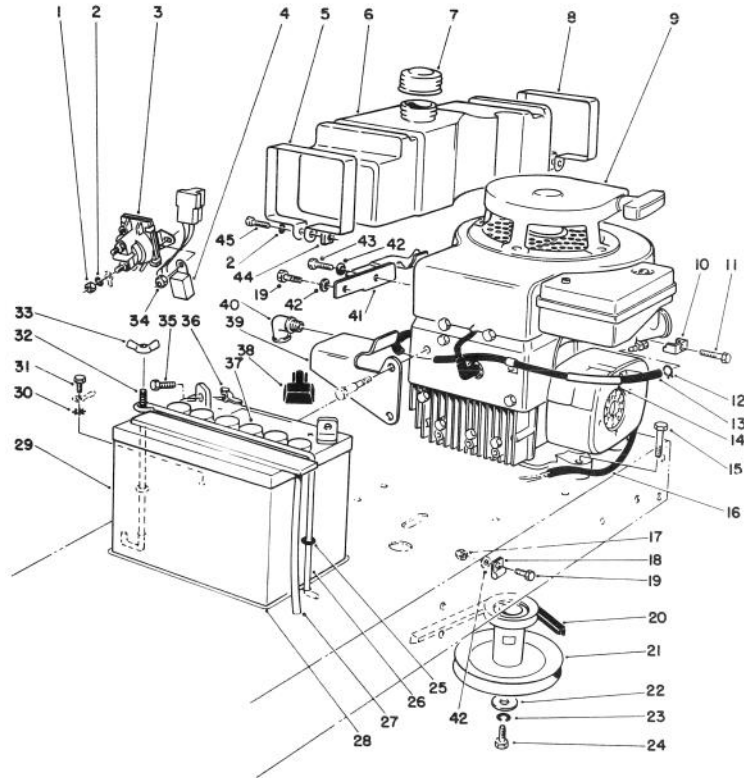
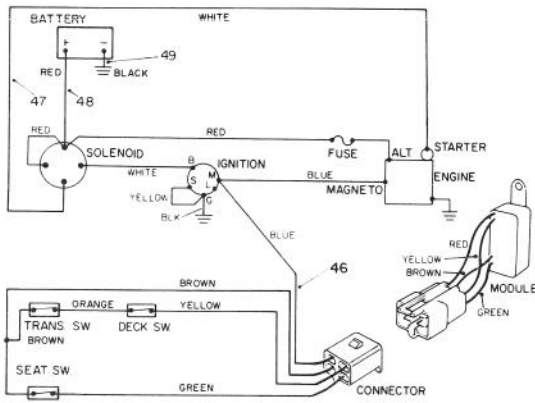

## ENGINE ASSEMBLY

Ref. No.	Part No.	Description	No. Used
1	3218-1	Nut — Hex. Jam	2
2	3253-3	Washer — Lock	4
3	47-1910	Solenoid	1
4	39-6520	Module — Interlock	1
5	57-4060	Retainer — Tank (Front)	1
6	56-7050	Tank — Gas	1
7	55-3570	Gas Cap Assembly	1
8	57-4070	Retainer — Tank (Rear)	1
9		Engine — 8 H.P. (Model 56150)	1
*		Engine — 12 H.P. (Model 56175)	1
10	2210-249	Clamp — Casing	1
11	2210-248	Screw — Hex. Hd.	1
12	2412-98	Clamp — Fuel Line	2
13	47-2986	Line — Fuel (Model 56150)	1
*	47-2961	Line — Fuel (Model 56175)	1
14	62-5490	Support — Fuel Line	1
15	322-7	Capscrew — Hex. Hd.	4
16	57-4150	Cover — Protective	1
17	3296-29	Nut — Lock	1
18	2412-68	Clamp	1
19	322-4	Screw — Hex. Hd.	2
20	47-1410	Belt — Traction Drive	1
21	47-1960	Pulley — Engine	1
22	3256-25	Washer — Flat	1
23	3253-22	Washer — Lock	1
24	62-3760	Capscrew — Hex. Hd.	1
25	237-143	O-Ring	2
26	56-7710	Hold Down — Battery	1
27	56-2540	Tube — Battery Vent	1

Ref. No.	Part No.	Description	No. Used
28	62-4300	Pad — Anti-Skid	1
29	56-7700	Battery — 12V	1
30	3254-2	Washer — Lock External Tooth	1
31	32104-82	Screw — Hex. Hd. Self Tapping	1
32	56-7720	Post — Battery	1
33	32103-12	Nut — Wing	1
34	32152-4	Nut — Lock	2
35	321-3	Screw — Hex. Hd.	2
36	32103-22	Nut — Wing	2
37	218-560	Cap — Battery	6
38	28-8080	Boot — Terminal	1
39	57-4040	Bracket — Tank (Front) (Model 56150)	1
*	63-5570	Bracket — Tank (Front) (Model 56175)	1
40	2811-10	Elbow — 90° Street	1
41	57-4050	Bracket — Tank (Rear) (Model 56150)	1
*	63-5560	Bracket — Tank (Rear) (Model 56175)	1
42	3256-23	Washer — Flat	2
43	322-2	Screw — Hex. Hd.	1
44	32107-11	Nut — Square	2
45	3274-51	Screw — Hex. Hd.	2
46	56-7690	Wiring Harness	1
47	56-7660	Wiring Harness — Starter	1
48	56-7670	Cable — Battery Positive	1
49	56-7870	Cable — Battery Negative	1
*	3290-378	Cable Tie	1

\* Not Illustrated



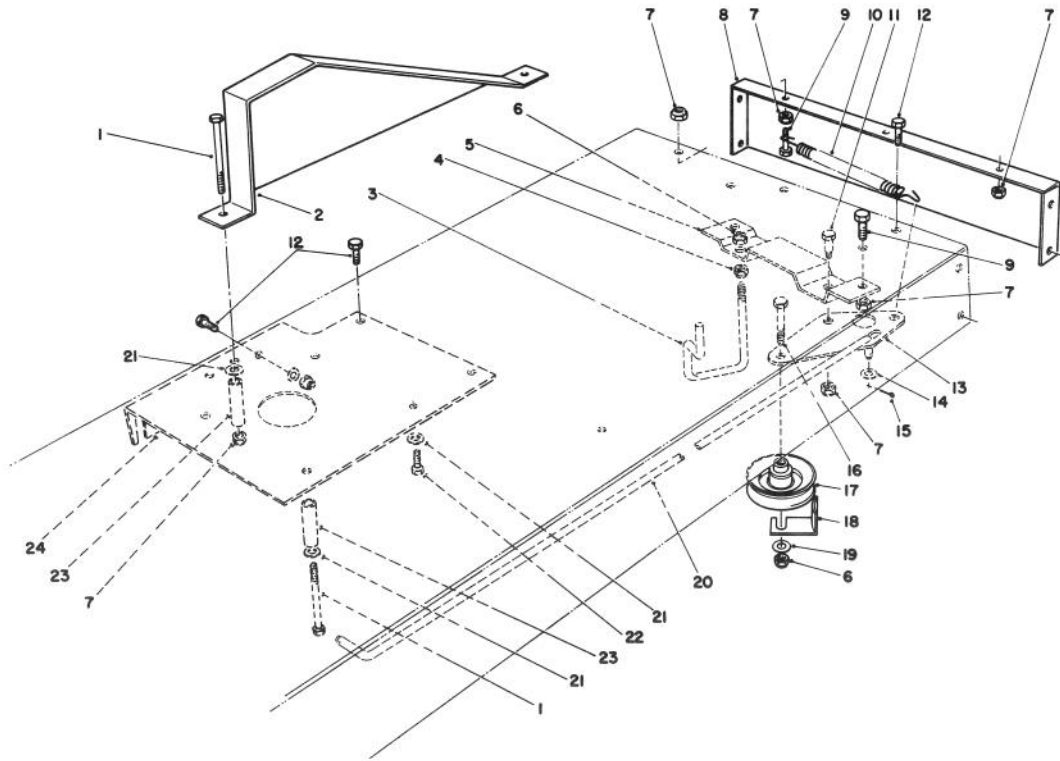

## TRACTION ASSEMBLY

Ref. No.	Part No.	Description	No. Used
1	322-11	Capscrew — Hex. Hd.	2
2	47-1220	Guard — Chain	1
3	47-0500	Guide — Belt	1
4	32153-2	Locknut	1
5	47-0471	Bracket — Traction Support	1
6	32152-2	Nut — Lock	2
7	3296-29	Nut — Lock	8
8	47-0730	Frame — Rear	1
9	322-7	Capscrew	2
10	27-8960	Spring — Extension	1
11	37-8770	Screw — Shoulder	1
12	322-3	Capscrew	4

Ref. No.	Part No.	Description	No. Used
13	47-0481	Bracket — Traction Pivot	1
14	3256-22	Washer — Plain	1
15	3272-6	Pin — Cotter	1
16	323-9	Capscrew — Hex. Hd.	1
17	12-5820	Pulley — Idler	1
18	12-9020	Retainer — Belt	1
19	3256-24	Washer — Plain	1
20	47-0490	Rod — Traction	1
21	3256-23	Washer	7
22	32140-45	Screw — Machine Hex. Hd.	3
23	47-0920	Spacer — Split	2
24	47-1950	Plate — Reinforcement	1

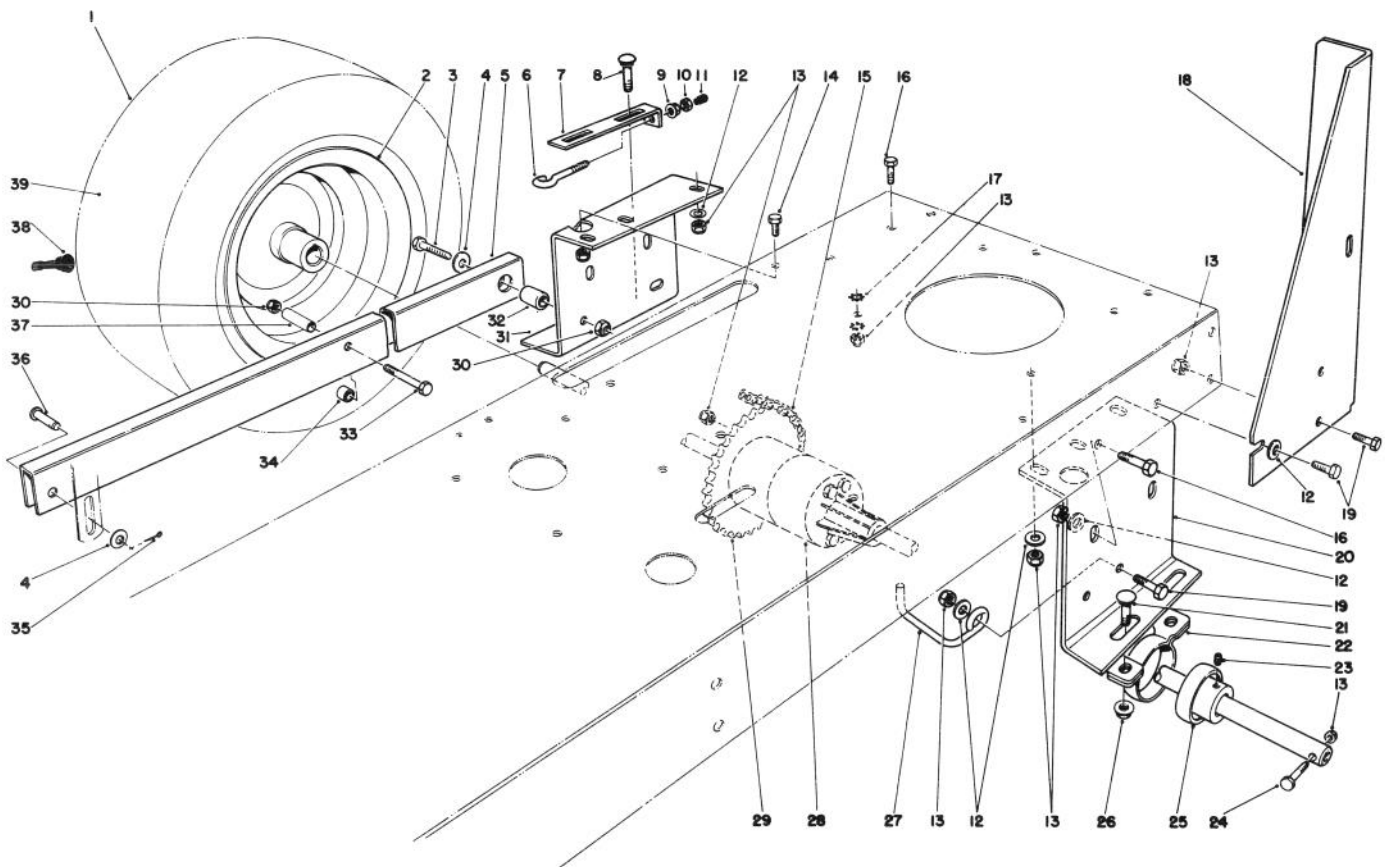

## REAR AXLE ASSEMBLY

Ref. No.	Part No.	Description	No. Used
1	231-117	Tire	2
2	242-78	Rim	2
3	323-9	Screw — Hex. Hd.	2
4	3256-24	Washer — Plain	4
5	47-0020	Arm — Rear Deck Suspension	2
6	61-9980	Screw — Adjusting	1
7	61-9990	Plate — Adjusting	1
8	3231-25	Bolt — Carriage	2
9	32128-33	Nut — Flange	1
10	3217-5	Nut — Hex.	1
11	2410-66	Tip — Rod	1
12	3256-23	Washer — Plain	12
13	3296-29	Nut — Lock	18
14	322-3	Screw — Hex. Hd.	1
15	56-7230	Chain — Roller	1
16	322-4	Capscrew — Hex. Hd.	4
17	3254-2	Lockwasher — External Tooth	2
18	56-7450	Standbar — L.H.	1
*	56-7440	Standbar — R.H.	1
19	322-5	Capscrew — Hex. Hd.	7
20	56-7420	Support — Rear Axle L.H.	1

Ref. No.	Part No.	Description	No. Used
21	3231-30	Bolt — Carriage	2
22	47-1480	Retainer — Pillow Block	2
23	3245-35	Set Screw	4
*	3246-15	Set Screw	4
24	322-9	Screw — Hex. Hd.	2
25	47-1490	Bearing — Ball (Incl. Ref. #23)	2
26	32128-21	Nut — Lock Flange	4
27	47-2010	Belt Guide — Engine Pulley	1
28	56-7120	Differential	1
29	56-7090	Sprocket Differential	1
30	32152-2	Nut — Lock	4
31	63-5820	Support — Rear Axle R.H.	1
32	56-7430	Pin — Arm Support	2
33	323-13	Capscrew — Hex. Hd.	2
34	47-0910	Spacer — Inner Tube	2
35	3272-6	Pin — Cotter	2
36	283-42	Pin — Clevis	2
37	47-0920	Spacer — Split	2
38	232-27	Valve Stem w/Cap	2
39†	232-39	Inner Tube	2

\* Not Illustrated

† Service Replacement Part

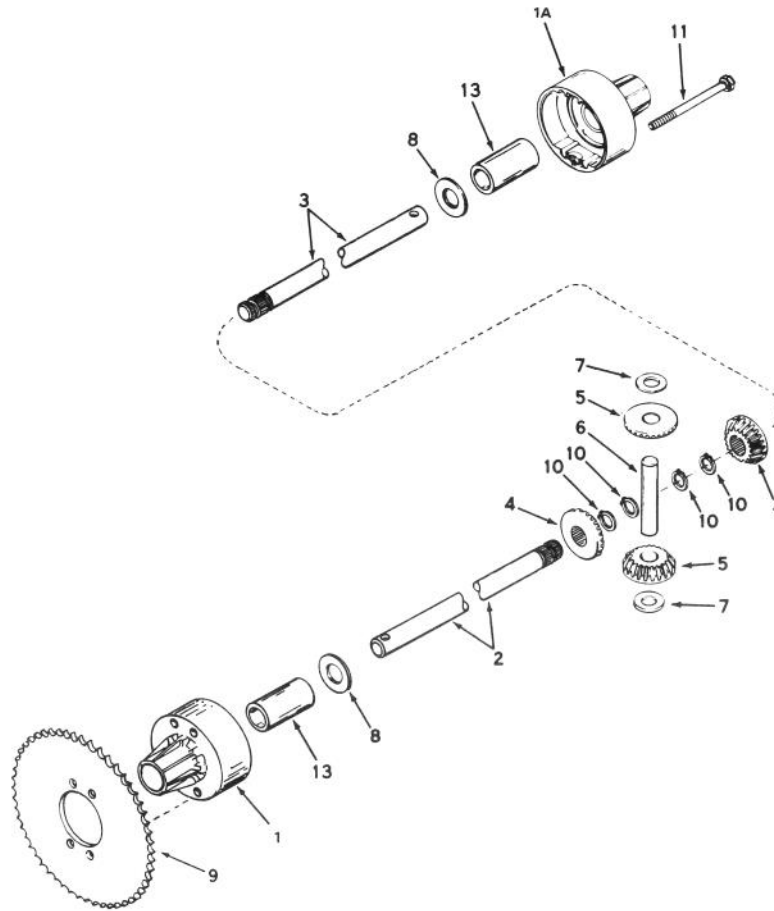

## DIFFERENTIAL MODEL 100-050B

Ref. No.	Part No.	Description	No. Used
1	774344	Housing — Differential Carrier (Incl. #13)	1
1A	774345	Housing — Differential Carrier (Incl. #13)	1
2	774708A	Axle (10-1/4" long)	1
3	774709A	Axle (18-7/8" long)	1
4	778221	Gear — Bevel	2
5	778068	Gear — Pinion	2

Ref. No.	Part No.	Description	No. Used
6	786040	Pin — Drive	1
7	780096	Washer — Thrust	2
8	780001	Washer	2
9		Sprocket (See "Sprocket Chart" for optional sprocket)	2
10	792125	Ring — Retaining (Pkg. of 2)	4
11	792041	Screw — Flanged Hex. Hd.	4
13	780077	Bushing	2

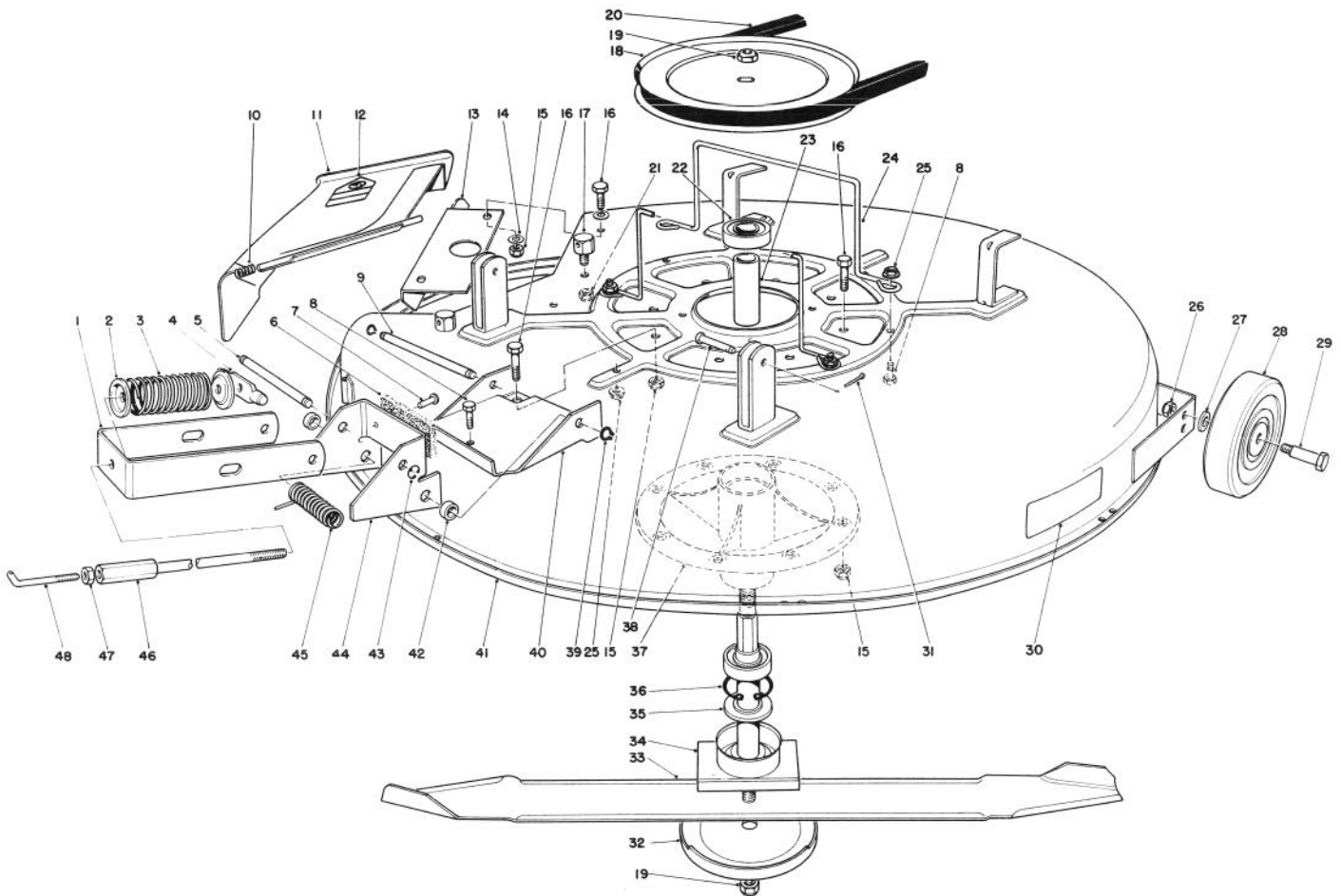

## MOWER ASSEMBLY

Ref. No.	Part No.	Description	No. Used
1	47-1180	Bracket — Engagement	1
2	47-1140	Retainer — Spring Top	2
3	47-0960	Spring — Compression	1
4	47-1200	Shaft — Adjusting	1
5	47-1230	Pin — Clevis	1
6	47-0210	Pad — Brake	1
7	3295-43	Rivet	2
8	321-4	Capscrew	5
9	47-1670	Pin — Clevis	1
10	28-8010	Spring — Torsion	1
11	44-5930	Deflector Assembly (Incl. Ref. #12)	1
12	54-9220	Decal — Deflector Caution	1
13	44-5720	Baffle Deck	1
14	3256-23	Washer — Plain	4
15	3296-29	Nut — Lock	10
16	322-4	Capscrew	10
17	28-7350	Pivot Post	1
18	47-1350	Pulley	1
19	17-0980	Nut — Special	2
20	47-1420	V-Belt	1
21	32153-2	Nut — Lock	1
22	251-297	Bearing	2
23	47-0100	Spacer — Bearing	1
24	60-9730	Guide — Belt	2

Ref. No.	Part No.	Description	No. Used
25	32128-10	Nut — Locking Flange	5
26	3296-39	Nut — Lock	2
27	3256-24	Washer — Plain	2
28	61-9760	Wheel	2
29	56-6590	Wheel Bolt	2
30	47-7240	Decal — Deck	1
31	3272-6	Cotter Pin	2
32	7-3522	Anti-Scalp Cup	1
33	33-4750	Blade	1
34	47-0090	Spindle Shaft	1
35	47-0110	Spacer — Spindle	1
36	32120-11	Ring — Retaining Internal	1
37	56-7030	Spindle Body	1
38	283-2	Pin Clevis	2
39	32151-57	Ring — Retaining External	2
40	47-1240	Channel — Deck Engagement	1
41	47-1600	Cutter Deck	1
42	47-1900	Spacer — Deck Brake Support	2
43	32120-18	Ring — Retaining External	2
44	47-1610	Support Deck Brake Assembly (Incl. Ref. #6 & 7)	1
45	40-6230	Spring — Torsional	1
46	47-1150	Hub — Adjusting	1
47	3218-3	Nut — Jam	1
48	47-1130	Rod — Adjusting	1

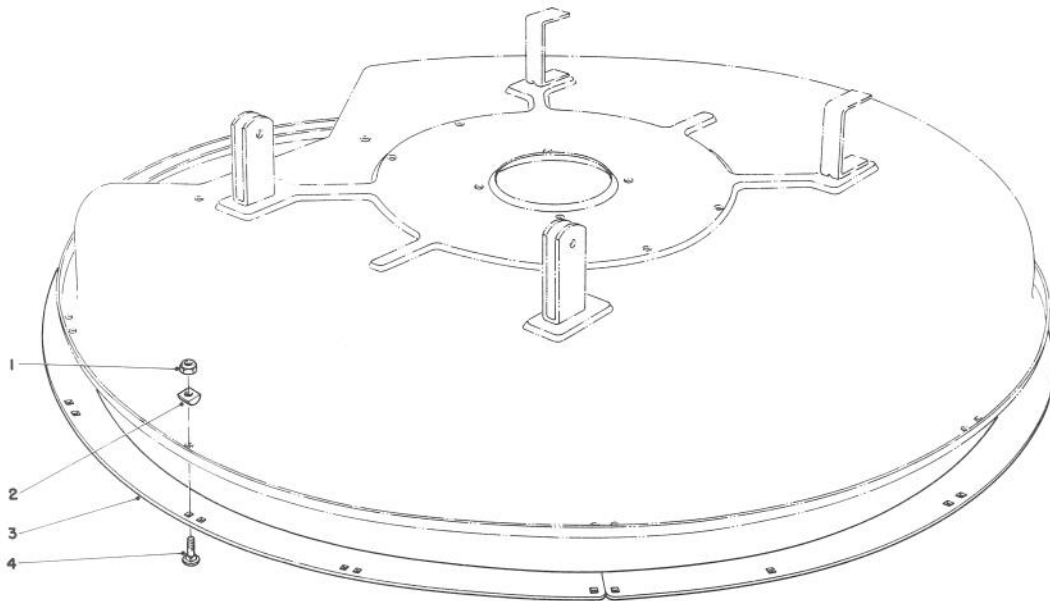

### WET GRASS BAGGING KIT NO. 38-5730 (Optional)

Ref. No.	Part No.	Description	No. Used
1	3296-29	Locknut	12
2	56-7880	Spacer — Deck Ring	12

Ref. No.	Part No.	Description	No. Used
3	38-6030	Ring — Deck	4
4	3230-2	Carriage Bolt	12

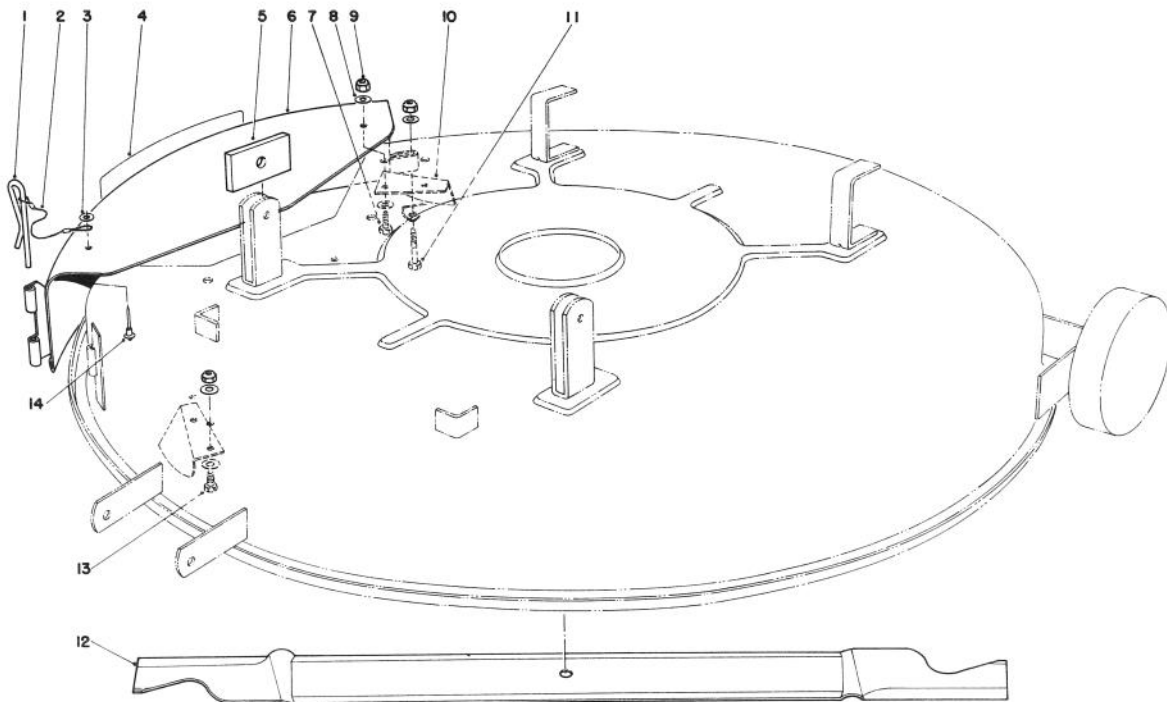

## MULCHER KIT MODEL 59155 (Optional)

Ref. No.	Part No.	Description	No. Used
1	28-8130	Pin — Chute Locking	1
2	28-8070	Lanyard	1
3	3256-49	Washer	1
4	44-5910	Decal — Mulcher Cover	1
5	44-5820	Spacer — Deck Angle	2
6	44-5700	Cover — Mulcher Assembly (Incl. Ref. #1-4 & 14)	1
7	322-5	Capscrew — Hex. Head	1

Ref. No.	Part No.	Description	No. Used
8	3256-23	Washer	9
9	3296-29	Locknut	5
10	44-5810	Kicker	2
11	322-10	Capscrew — Hex. Head	1
12	39-3480	Blade — Mulcher	1
13	322-3	Capscrew — Hex. Head	3
14	3290-282	Rivet — Pop	1

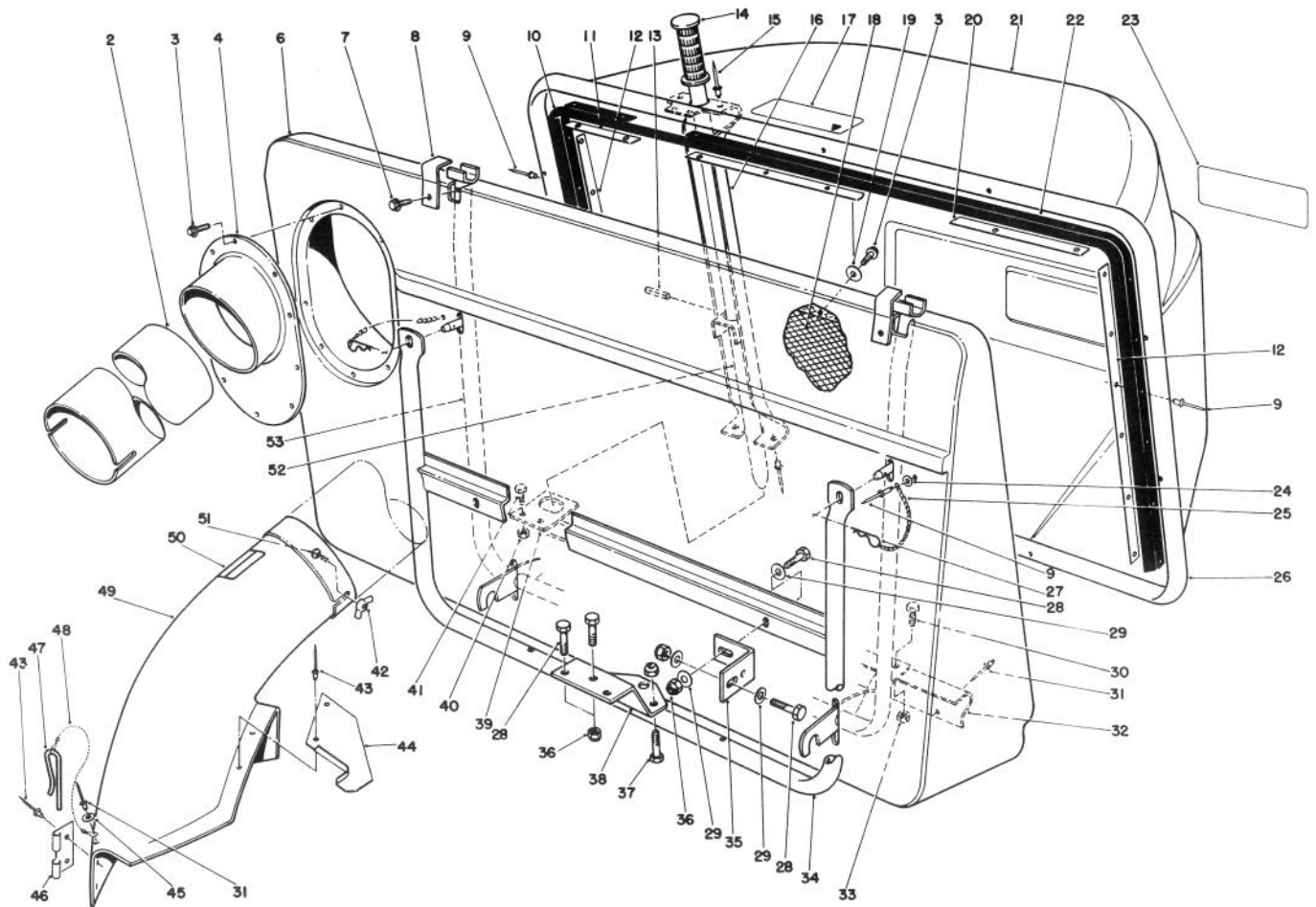

## EASY-EMPTY GRASS CATCHER MODEL 59111 (Optional)

Ref. No.	Part No.	Description	No. Used
2	47-7210	Duct	1
3	32104-76	Screw — Self Tapping	18
4	62-4240	Adaptor Duct	1
6	28-7810	Bag — Front	1
7	32104-60	Screw — Hex. Hd. Self Tapping	2
8	28-7700	Retainer Pivot Bracket	2
9	3290-415	Domed Head Rivet	22
10	36-2520	Seal — Bag R.H.	1
11	29-5540	Retainer — External Top	1
12	29-5550	Retainer — External Bag	2
13	32121-79	Pin — Roll	1
14	233-40	Grip — Handle	1
15	3290-409	Rivet — Domed Head	16
16	38-2920	Channel — Dump Handle	1
17	55-7270	Decal — Warning	1
18	28-7840	Screen — Bag	1
19	3256-61	Washer — Fender	8
20	62-4230	Retainer	1
21	36-2120	Grass Basket — Rear	1
22	36-2530	Seal — Bag L.H.	1
23	25-2200	Decal	1
24	5-1254	Washer	2
25	2830-10	Chain	2
26	28-7670	Frame — Bag Support	1
27	3290-355	Hair Pin Cotter	2
28	322-4	Capscrew — Hex. Hd.	7
29	3256-23	Washer — Plain	9

Ref. No.	Part No.	Description	No. Used
30	322-2	Capscrew — Hex. Hd.	2
31	3290-282	Rivet	5
32	28-7830	Frame Support Bracket	1
33	32152-1	Nut — Lock	2
34	28-7780	Support — Bag	1
35	56-7190	Bracket — Mounting Grass Catcher	2
36	3296-29	Nut — Lock	9
37	322-7	Capscrew — Hex. Hd.	4
38	51-2970	Bracket — Mounting Grass Catcher	1
39	28-7820	Hanger — Frame Tower	1
40	32152-4	Nut — Lock	2
41	321-3	Capscrew — Hex. Hd.	2
42	32103-14	Wing — Nut	2
43	3290-412	Rivet	4
44	33-2090	Bracket — Chute Support	1
45	3256-49	Washer	1
46	28-8050	Bracket — Chute Mounting	1
47	28-8130	Pin — Chute Locking	1
48	28-8070	Lanyard	1
49	28-8060	Chute Assembly (Incl. Ref. #31, 41-50)	1
50	54-9220	Decal — Danger	1
51	3229-1	Carriage Bolt	2
52	29-5470	Handle — Dump	1
53	28-7710	Bag — Frame	1



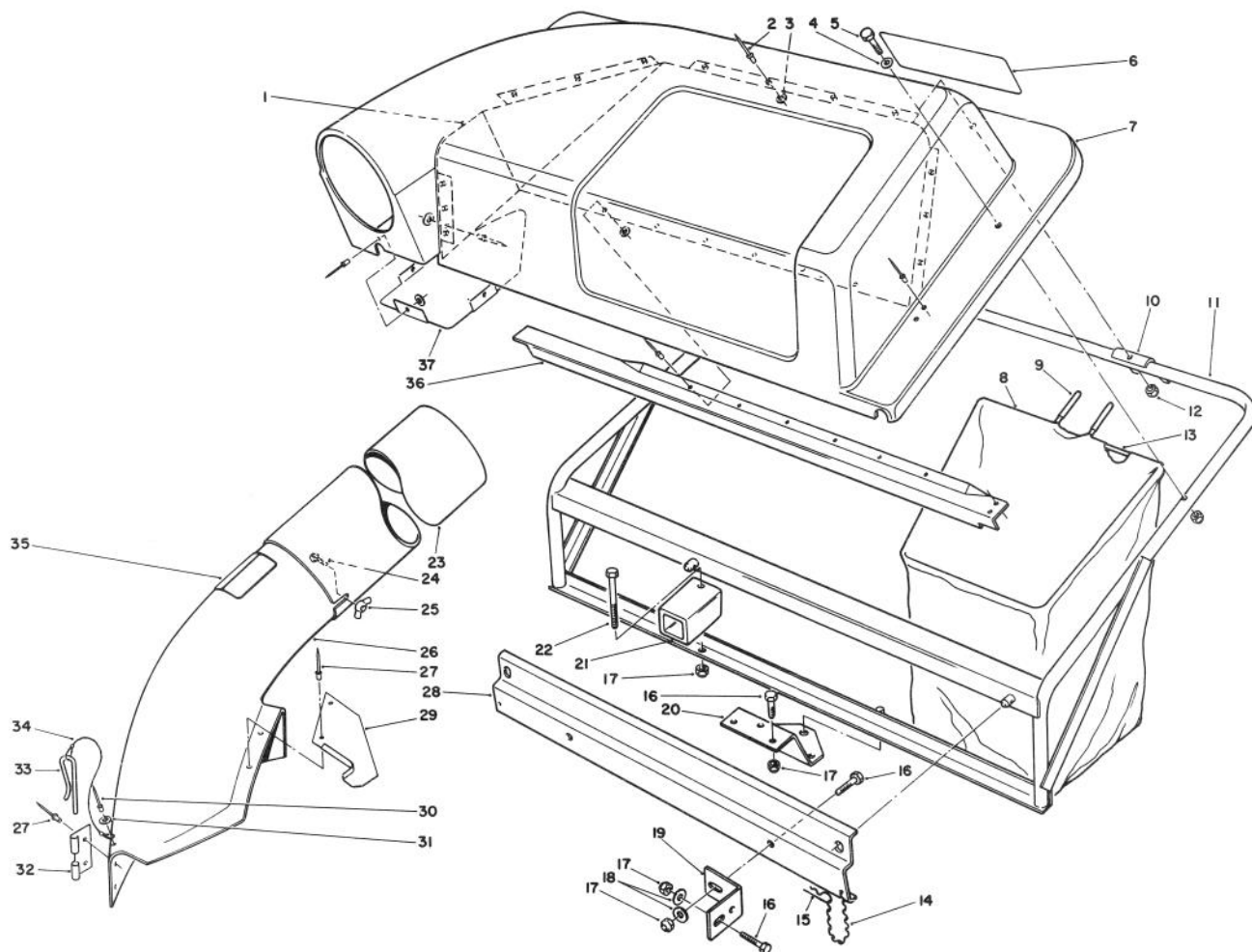

## TWIN BAGGER GRASS CATCHER MODEL NO. 59122 (Optional)

Ref. No.	Part No.	Description	No. Used
1	36-4230	Screen — Cover	1
2	3269-4	Rivet — Pop	23
3	3256-14	Washer — Plain	21
4	3256-23	Washer — Plain	4
5	322-7	Capscrew — Hex. Hd.	4
6	47-6890	Decal — Twin Bagger	1
7	47-2190	Cover	1
8	47-2570	Bag — Twin Bagger	2
9	47-2550	Grip — Bag Handle	4
10	47-2580	Bracket — Bag Frame	2
11	47-2630	Frame	1
12	32111-8	Nut — Acorn	4
13	47-2620	Frame — Bag	2
14	2830-9	Chain	2
15	3290-355	Hair Pin Cotter	2
16	322-4	Capscrew	7
17	3296-29	Nut — Lock	8
18	3256-23	Washer — Flat	8
19	56-7190	Bracket — Mtg. Grass Catcher	2
20	51-2970	Plate — Mtg. Grass Catcher	1

Ref. No.	Part No.	Description	No. Used
21	51-2960	Tube — Frame Support	1
22	322-10	Capscrew — Hex. Hd.	1
23	47-7210	Duct	1
24	3229-1	Carriage Bolt	2
25	32103-14	Nut — Wing	2
26	28-8060	Chute Assembly (Incl. Ref. #27, 29-35)	1
27	3290-412	Pop Rivet	4
28	36-4550	Bracket — Frame Support	1
29	33-2090	Bracket Chute Support	1
30	3290-282	Pop Rivet	1
31	3256-49	Washer — Plain	1
32	28-8050	Bracket Chute Mounting	1
33	28-8130	Pin — Chute Locking	1
34	28-8070	Lanyard	1
35	54-9220	Decal — Instruction Chute	1
36	47-2650	Bracket — Screen Support	1
37	47-6760	Shield — Cover	1
*	12-7039	Loose Parts	1

\* Not Illustrated

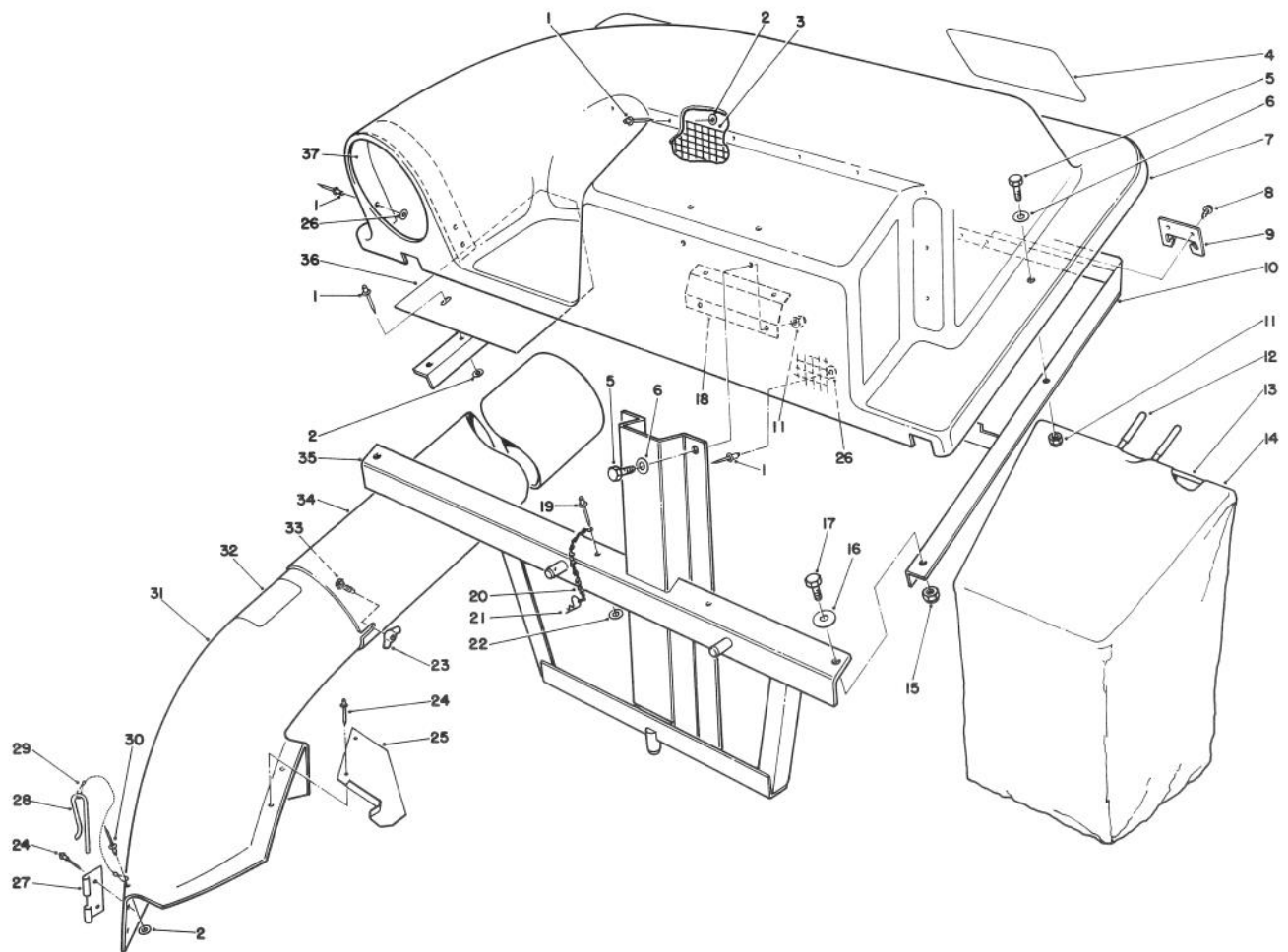

## TWIN BAGGER GRASS CATCHER MODEL NO. 59184 (Optional)

Ref. No.	Part No.	Description	No. Used
1	3269-4	Rivet — Pop	22
2	3256-49	Washer — Plain	13
3	61-9890	Screen	1
4	62-3640	Decal	1
5	322-5	Capscrew — Hex. Hd.	8
6	3256-23	Washer — Plain	8
7	61-9790	Cover	1
8	32144-4	Screw — Hex Hd.	4
9	61-9860	Bracket — Bag Frame	2
10	61-9810	Cover — Frame W.A.	1
11	3296-29	Nut — Lock	8
12	47-2550	Grip — Bag Handle	4
13	47-2620	Frame — Bag	2
14	47-2570	Bag — Twin Bagger	2
15	3296-44	Nut — Lock	2
16	3256-24	Washer — Plain	2
17	323-6	Capscrew — Hex. Hd.	2
18	61-9880	Plate — Back Up	1
19	3290-415	Rivet — Pop	2
20	2830-10	Chain	2

Ref. No.	Part No.	Description	No. Used
21	3290-355	Hairpin — Cotter	2
22	3269-10	Washer	2
23	32103-14	Nut — Wing	2
24	3290-412	Rivet — Pop	4
25	33-2090	Bracket — Chute Support	1
26	3256-14	Washer — Plain	10
27	28-8050	Bracket — Chute Mounting	1
28	28-8130	Pin — Chute Locking	1
29	28-8070	Lanyard	1
30	3290-282	Rivet — Pop	1
31	28-8060	Chute Assembly (Incl. Ref. #24-30 & 32)	1
32	54-9220	Decal — Instruction	1
33	3229-1	Carriage Bolt	2
34	47-7210	Duct	1
35	61-9900	Mounting Frame W.A.	1
36	61-9870	Baffle	1
37	62-6890	Support Inlet	1
*	12-7049	Loose Parts	1

\* Not Illustrated

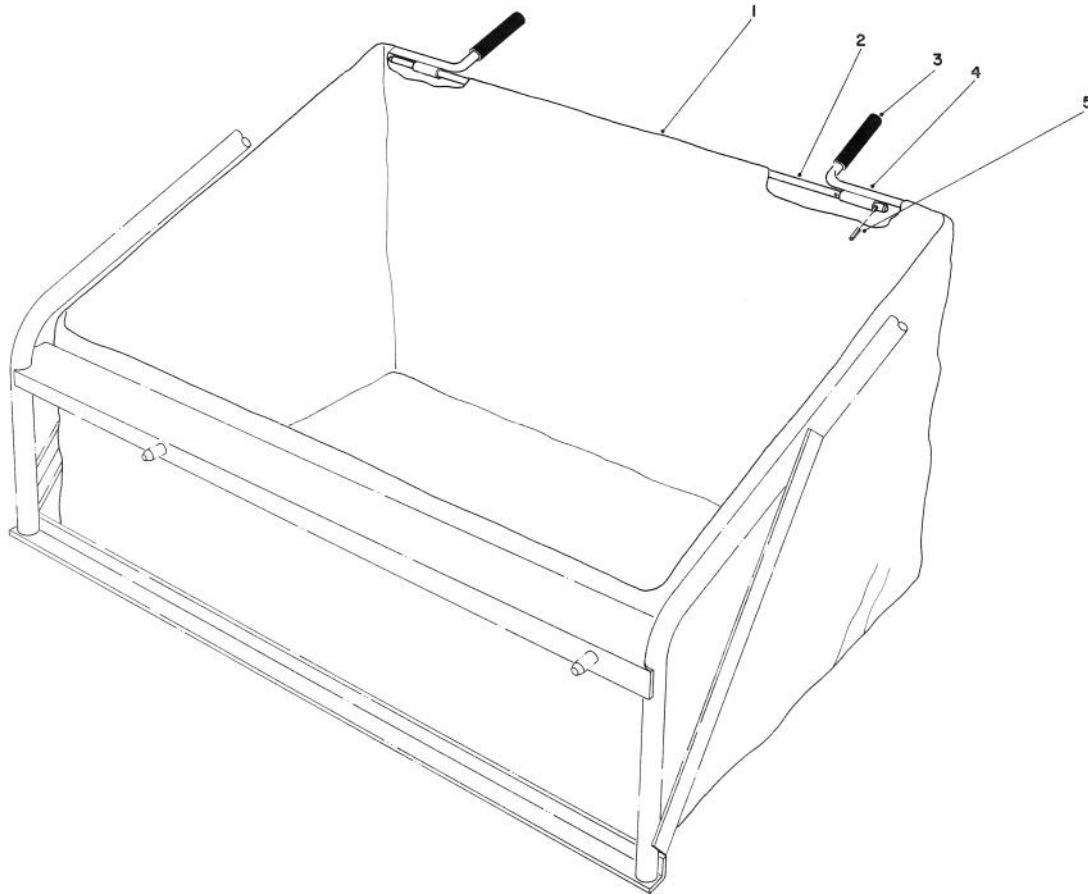

**LEAF BAG MODEL 59123 (FOR USE ON TWIN BAGGER GRASS CATCHER MODEL NO. 59122 ONLY) (Optional)**

Ref. No.	Part No.	Description	No. Used
1	47-6860	Bag — Leaf Catcher	1
2	47-6800	Rod — Bag Frame	1
3	47-6710	Grip — Leaf Bag Handle	2

Ref. No.	Part No.	Description	No. Used
4	47-6830	Bag Frame	1
5	32121-73	Rollpin	2
*	505-78	Adhesive — Plastic	1

\* Not Illustrated

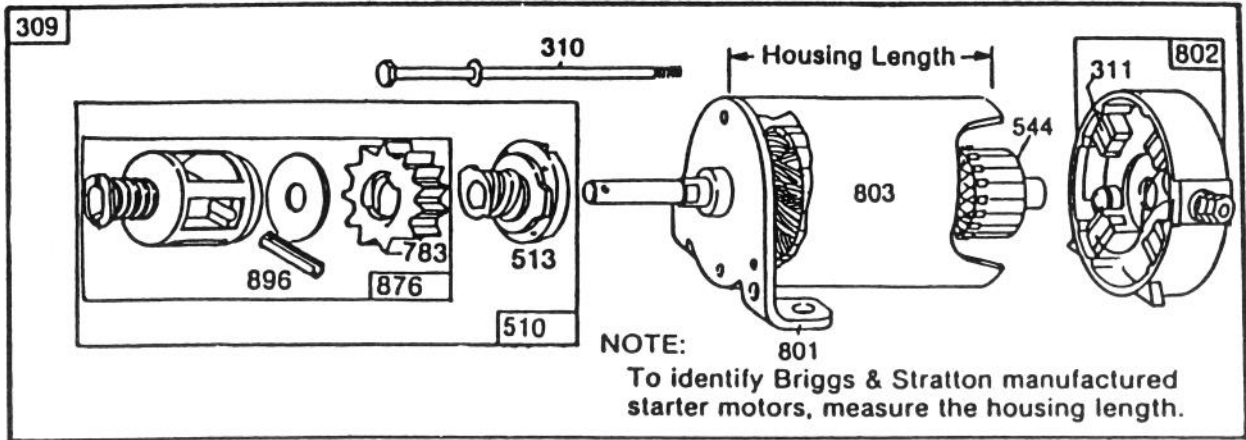

Assemblies include all parts shown in frames.

## BRIGGS & STRATTON STARTER MOTOR ASSEMBLY 8 H.P. REAR ENGINE RIDER MODEL 56150

Ref. No.	Part No.	Description	No. Used
309	394805	Motor and Drive Assembly	1
310	94003	Thru Bolt Assembly	1
311	395538	Brush Assembly	1
510	396865	Drive Assembly	1
513	391135	Clutch Assembly	1
544	390837	Armature Assembly	1

Ref. No.	Part No.	Description	No. Used
783	280104	Gear	1
801	394856	End Cap Assembly Drive	1
802	395537	End Cap Assy. Commutator	1
803	393825	Housing Assembly	1
876	393254	Retainer Kit	1
896	93754	Roll Pin	1

# ENGINE BRIGGS & STRATTON MODEL NO. 193707-0152-01 8 H.P. REAR ENGINE RIDER ELECTRIC MODEL 56150

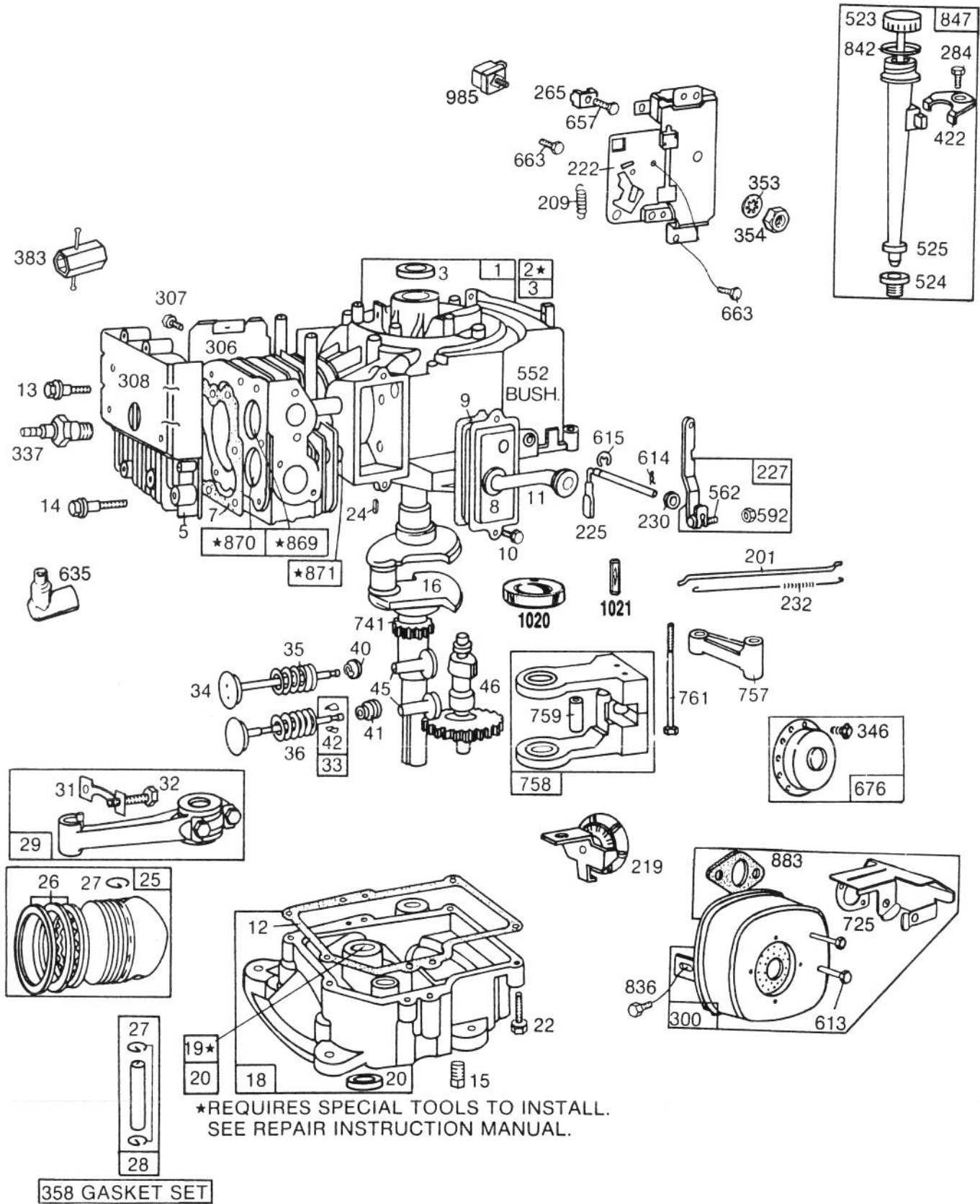

# ENGINE BRIGGS & STRATTON MODEL NO. 193707-0152-01

## 8 H.P. REAR ENGINE RIDER ELECTRIC MODEL 56150

Ref. No.	Part No.	Description	No. Used
1	397240	Cylinder Assembly	1
2	261960	Bushing — Cylinder <b>Note:</b> Requires Special Tools for Installation	1
3	294606	Seal — Oil	1
5	212286	Head — Cylinder	1
7	*270430	Gasket — Cylinder Head	1
8	391406	Breather Assembly	1
9	*27803	Gasket — Valve Cover	1
10	93394	Screw	1
11	280005	Tube — Breather	1
12	*27750	Gasket — Crankcase Cover 1/64" thick	1
	*27876	Gasket — Crankcase Cover .005" thick	1
	*27877	Gasket — Crankcase Cover .009" thick	1
13	93211	Screw — Cylinder Head (2-21/32" long)	1
14	93723	Screw — Cylinder Head (3" long) 1 Req'd.	1
15	91084	Plug — Oil Drain	1
16	396876	Crankshaft <b>Note:</b> To Replace Crankshaft Gear Pin — Order Part No. <b>230978</b>	1
18	392548	Base — Engine	1
19	295963	Bushing — Oil Base <b>Note:</b> Requires Special Tools for Installation	1
20	391086	Seal — Oil	1
22	93585	Screw — Base Mounting	1
24	222698	Key — Flywheel	1
25	393868	Piston Assembly — Standard	1
	393869	Piston Assembly — .010" O.S.	1
	393879	Piston Assembly — .020" O.S.	1
	393880	Piston Assembly — .030" O.S. <b>Piston Ring Sets:</b> <b>Note:</b> For Chrome Piston Ring Set — Standard Size Order No. <b>299743</b>	1
26	393881	Ring Set — Piston — Std.	1
	393882	Ring Set — Piston — .010" O.S.	1
	393883	Ring Set — Piston — .020" O.S.	1
	393884	Ring Set — Piston — .030" O.S.	1
27	68546	Lock — Piston Pin	1
28	295840	Pin Assembly — Piston — Standard	1
	295841	Pin Assembly — Piston — .005" O.S.	1
29	390402	Rod Assy. — Connecting <b>Note:</b> For Connecting Rod with .020" Undersize Crankpin Bore — Order No. <b>390773</b>	1
31	222114	Lock — Connecting Rod Screw	1
32	92659	Screw — Connecting Rod	1
33	390420	Valve — Exhaust	1
34	261055	Valve — Intake	1
35	65906	Spring — Intake Valve	1
36	26828	Spring — Exhaust Valve	1
40	221596	Retainer — Intake Valve	1

Ref. No.	Part No.	Description	No. Used
41	292260	Rotocoil — Exhaust Valve	1
42	93630	Retainer — Exhaust Valve Rotocoil	2
45	260933	Tappet — Valve	1
46	211689	Gear — Cam	1
201	261611	Link — Governor	1
209	260871	Spring — Governor	1
219	392718	Oil Slinger — Gov. Gear and Bracket Assembly	1
222	390784	Plate — Gov. Control	1
225	231058	Crank — Governor (1/4" Dia.)	1
227	391733	Lever Assy. — Governor For 1/4" Dia. Crank	1
230	222450	Washer — Gov. Lever (1/4" I.D.)	1
232	261911	Spring — Governor Link	1
265	221535	Clamp — Casing	1
284	93804	Screw — Clamp Mtg.	1
300	398507	Muffler — Exhaust	1
306	222830	Shield — Cylinder	1
307	93163	Screw — Cylinder Shield Mtg.	1
308	222636	Cover — Cylinder Head	1
337	293918	Plug — Spark (1-1/2" high — 37 M.M.) (Resistor Type)	1
346	93705	Screw	1
353	92791	Washer — Lock — Shakeproof	1
354	90576	Nut — Hex.	1
358	299577	Gasket Set	1
383	89838	Wrench — Spark Plug	1
422	222502	Clamp — Oil Filler Tube	1
523	391840	Cap and Dipstick — Oil Filler	1
524	68838	Seal — Filler Tube	1
525	280133	Tube — Oil Filler	1
552	231055	Bushing — Gov. Crank (1/4" I.D.)	1
562	92613	Bolt — Governor Lever	1
592	231082	Nut — Hex.	1
613	94042	Screw — Muffler Mtg.	1
614	93306	Cotter — Hair Pin	1
615	93307	Retainer — E-Ring	1
635	66538	Elbow — Spark Plug	1
657	93496	Screw	1
663	93572	Screw	1
676	395700	Deflector — Exhaust	1
725	223450	Shield — Muffler	1
741	261195	Gear — Timing	1
757	212359	Link — Counterweight	1
758	390172	Counterweight Assy.	1
759	298909	Pin — Counterweight	1
761	93874	Screw — Counterweight	1
836	93559	Screw	1
842	270920	Seal — Filler Cap	1
847	392066	Filler Group — Oil	1
869	211661	Seat — Intake Valve (Standard)	1
870	211661	Seat — Exhaust Valve (Standard)	1
871	261961	Guide — Exhaust Valve <b>Note:</b> <b>231218</b> Guide — Intake Valve (Brass) <b>See Repair Manual</b>	1
883	270918	Gasket — Exhaust Pipe	1
985	398525	Insulator Assembly	1
1020	261190	Eccentric — Crankshaft	1
1021	94160	Pin — Eccentric	1

\* Included in Gasket Set — Part No. 299577.



# ENGINE BRIGGS & STRATTON MODEL NO. 193707-0152-01 (Continued)

## 8 H.P. REAR ENGINE RIDER ELECTRIC MODEL 56150

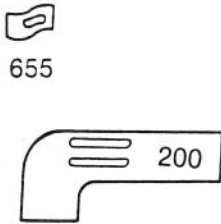
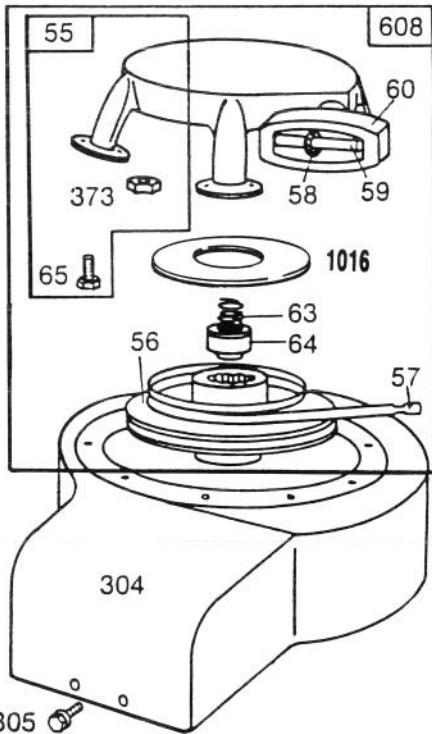
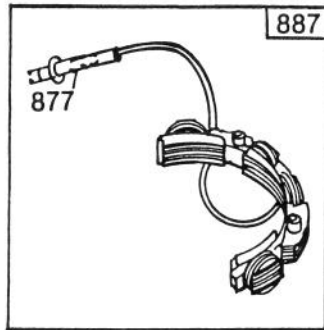
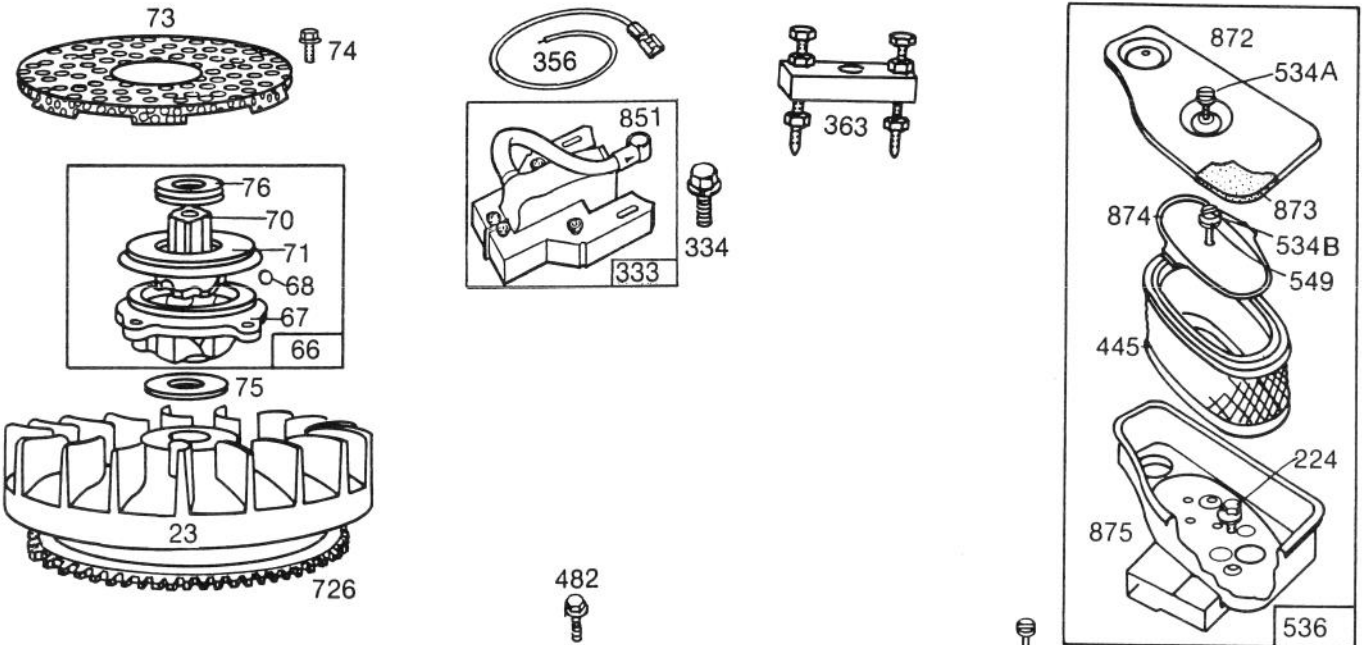

### 121 CARBURETOR OVERHAUL KIT

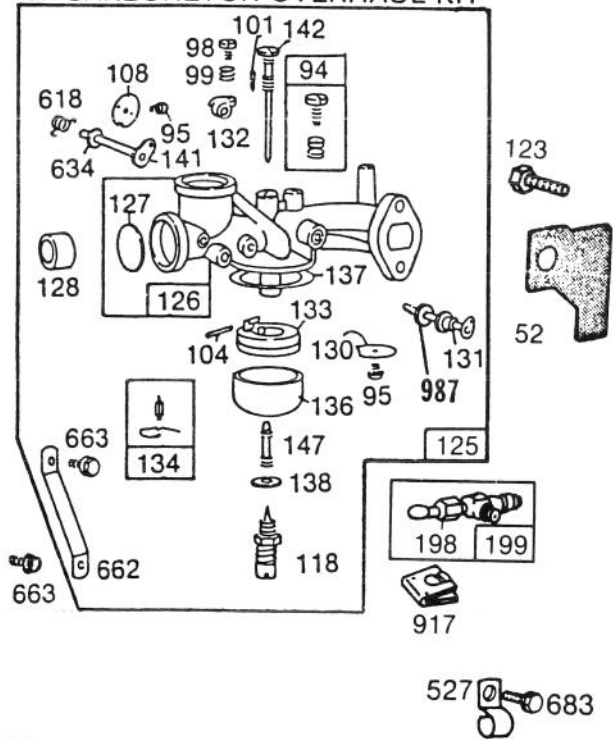



# ENGINE BRIGGS & STRATTON MODEL NO. 193707-0152-01 (Continued)

## 8 H.P. REAR ENGINE RIDER ELECTRIC MODEL 56150

Ref. No.	Part No.	Description	No. Used
23	391983	Flywheel and Ring Gear Assy. — Magneto For use on engines WITH ALTERNATOR. (Includes aluminum ring gear.)	1
52	*270824	Gasket — Carburetor Mounting	1
55	393576	Housing — Rewind Starter	1
56	295871	Pulley — Rewind Starter <b>Note:</b> Includes 63" Rope; if longer Rope is required, Order Rope No. <b>66894</b> and cut to required length.	1
57	490179	Spring — Rewind Starter	1
58	66884	Rope — Rewind Starter — 63" long; if longer Rope is needed, Order No. <b>66894</b> and cut to required length.	1
59	230228	Pin — Starter Grip	1
60	66728	Grip — Starter Rope	1
63	260414	Spring — Ratchet	1
64	230543	Adapter — Ratchet Spring	1
65	94128	Screw — Rewind Starter Housing Mtg.	1
66	394558	Clutch Assembly — Rewind Starter	1
67	394897	Housing — Rewind Starter Clutch	1
68	63770	Ball — Clutch	1
70	298799	Ratchet — Rewind Starter Clutch	1
71	221653	Washer — Retainer	1
73	221796	Screen — Rewind Starter	1
74	93042	Screw	1
75	220865	Washer — Spring	1
76	68238	Washer — Ratchet Sealing	1
94	†292681	Valve Assembly — Carburetor Idle	1
95	93499	Screw — Throttle and Choke Valve Mtg.	1
98	91920	Screw — Machine, Fill. Hd.	1
99	26157	Spring — Throttle Adjustment	1
101	93043	Pin — Throttle Stop	1
104	†230896	Pin — Float Hinge	1
108	222010	Valve — Choke	1
118	†396568	Valve — Needle	1
121	394698	Carburetor Overhaul Kit	1
123	93357	Screw — Carburetor Mtg.	1
125	390811	Carburetor Assembly (Choke-A-Matic)	1
126	299851	Body Assembly Carburetor	1
127	†221997	Plug — Welch	1
128	211682	Venturi — Carburetor	1

Ref. No.	Part No.	Description	No. Used
130	221986	Valve — Throttle	1
131	490017	Shaft and Lever — Throttle	1
132	211712	Stop — Throttle	1
133	299707	Float — Carburetor	1
134	†394681	Valve — Fuel Inlet	1
136	221995	Bowl — Float	1
137	†270511	Gasket — Float Bowl	1
138	†222014	Washer — Float Bowl	1
141	390684	Shaft and Lever — Choke	1
142	†299740	Nozzle — Carburetor	1
147	†231323	Screw — Nozzle	1
198	293934	Valve — Fuel Shut-Off	1
199	390303	Connector — Fuel Pipe	1
200	221760	Guide — Air	1
216	261612	Link — Choke	1
224	94018	Screw	1
304	391379	Housing — Blower	1
305	93158	Screw — Blower Housing Mounting	1
333	398811	Armature — Magneto	1
334	93381	Screw — Armature Mounting	1
356	398808	Wire — Ground	1
363	19165	Puller — Flywheel	1
373	92987	Nut — Hex.	1
445	393406	Cartridge — Air Cleaner	1
482	93621	Screw	1
527	221428	Clamp	2
534	93323	Screw — Air Cleaner	1
534A	93913	Screw — Air Cleaner	1
534B	93881	Screw — Air Cleaner	1
536	393481	Cleaner Assy. — Air	1
537	270539	Gasket — Air Cleaner	1
549	270978	Washer — Air Cleaner	1
608	390391	Starter Assy. — Rewind	1
618	261116	Spring — Choke Return	1
634	270382	Washer — Choke Shaft	1
655	222598	Anchor — Spring	1
662	222027	Bracket — Carburetor	1
663	93572	Screw	1
683	93572	Screw	1
726	392134	Gear — Ring (Aluminum) (Includes Mtg. Parts)	1
851	221798	Terminal — Ignition Cable	1
872	397981	Cover — Air Cleaner	1
873	397972	Gasket — Air Cleaner Cover	1
874	222898	Plate — Air Cleaner Cartridge	1
875	397320	Body — Air Cleaner	1
877	393814	Diode and Connector Assy.	1
887	391529	Stator Assembly — Alternator	1
917	223271	Valve Handle — Fuel Shut-Off	1
987	398970	Seal — Throttle Shaft	1
1016	490817	Spacer	1

\* Included in Gasket Set — Part No. 299577.

† Included in Carburetor Overhaul Kit — Part No. 394698.

# ENGINE BRIGGS & STRATTON MODEL NO. 281707-0175-01 12 H.P. REAR ENGINE RIDER ELECTRIC MODEL 56175

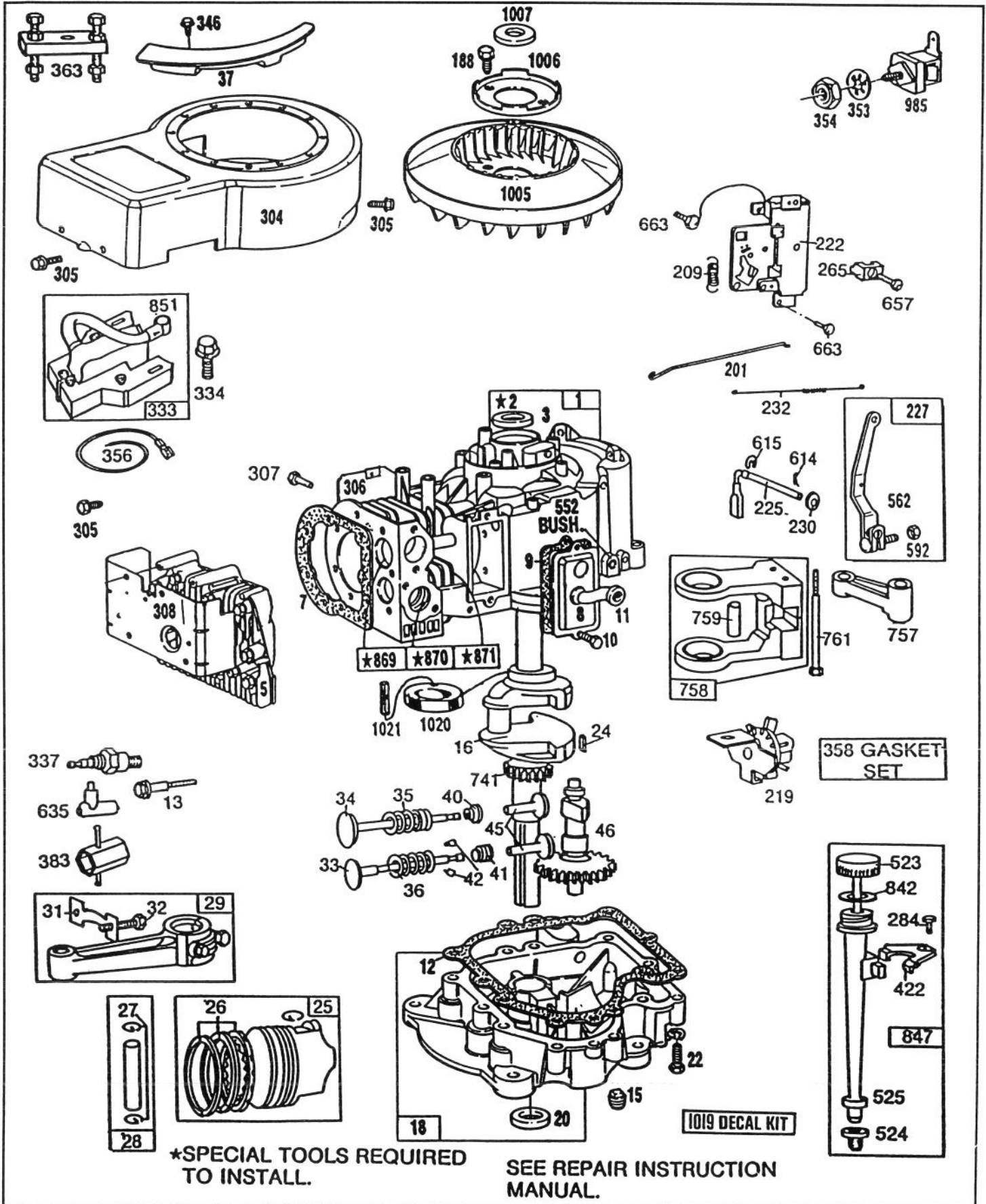

# ENGINE BRIGGS & STRATTON MODEL NO. 281707-0175-01

## 12 H.P. REAR ENGINE RIDER ELECTRIC MODEL 56175

Ref. No.	Part No.	Description	No. Used
1	490450	Cylinder Assembly	1
2	399265	Bearing — Cylinder	1
3	391086	Seal — Oil	1
5	491491	Head — Cylinder	1
7	*271866	Gasket — Cylinder Head	1
8	391406	Breather Assembly	1
9	*27803	Gasket — Valve Cover	1
10	93394	Screw — Sem	1
11	280100	Tube — Breather	1
12	*271916	Gasket — Crankcase Cover — 1/64" thick	1
	*271996	Gasket — Crankcase Cover — .005" thick	1
	*271997	Gasket — Crankcase Cover — .009" thick	1
13	93723	Screw — Cylinder Head (3" long) <b>Note: 93781 Stud — Cylinder Head</b> <b>231109 Spacer</b>	1
15	91084	Plug — Oil Drain	1
16	490466	Crankshaft <b>Note: Order Part Number 94196 for Timing Gear Key</b>	1
18	490452	Base — Engine	1
20	291675	Seal — Oil	1
22	94305	Screw — Base Mounting Sem	1
24	222698	Key — Flywheel	1
25	394661	Piston Assy. — Standard	1
	394662	Piston Assembly — .010" O.S.	1
	394663	Piston Assembly — .020" O.S.	1
	394664	Piston Assembly — .030" O.S. <b>PISTON RING SET</b> <b>Note: For Chrome Ring Set — Standard Size — Order No. 392331.</b>	1
26	394665	Ring Set — Piston — Std.	1
	391781	Ring Set — Piston — .010" O.S.	1
	391782	Ring Set — Piston — .020" O.S.	1
	391783	Ring Set — Piston — .030" O.S.	1
27	260924	Lock — Piston Pin	1
28	299691	Pin Assembly — Piston — Standard	1
	391286	Pin Assembly — Piston — .005" O.S.	1
29	490348	Rod Assembly — Connecting <b>Note: For Connecting Rod with .020" undersize Crankpin Bore — Order No. 490469.</b>	1
31	222299	Lock — Connecting Rod Screw	1
32	92909	Screw — Connecting Rod	1
33	262246	Valve — Exhaust	1
34	262247	Valve — Intake	1
35	65906	Spring — Intake Valve	1
36	26828	Spring — Exhaust Valve	1
37	223752	Guard — Flywheel	1
40	221596	Retainer — Intake Valves	1
41	292260	Rotocoil — Exhaust Valve	1
42	93630	Retainer — Exhaust Valve Rotocoil	2
45	262248	Tappet — Valve	1
46	212897	Gear — Cam	1

Ref. No.	Part No.	Description	No. Used
188	93535	Screw — Sem	1
201	262348	Link — Governor	1
209	260695	Spring — Governor	1
219	490815	Oil Slinger — Governor Gear and Bracket Assembly	1
222	491594	Plate — Governor Control	1
225	231058	Crank — Governor (1/4" dia.)	1
227	391733	Lever Assy. — Governor (For 1/4" dia. Crank)	1
230	222450	Washer — Governor Crank (1/4" I.D.)	1
232	260584	Spring — Governor Link	1
265	221535	Clamp — Casing	1
284	93804	Screw — Clamp Mtg.	1
304	490689	Housing — Blower	1
305	93158	Screw — Blower Housing Mounting Sem	1
306	223715	Shield — Cylinder	1
307	93163	Screw — Cylinder Shield Mounting Sem	1
308	491490	Cover — Cylinder Head	1
333	398811	Armature — Magneto	1
334	93381	Screw — Armature Mtg. Sem	1
337	293918	Plug — Spark (1-1/2" high) (Resistor Type)	1
346	93705	Screw — Sem	1
353	92791	Washer — Lock, Shakeproof	1
354	90576	Nut — Hex., 8-32	1
356	398808	Wire — Ground	1
358	490525	Gasket Set	1
363	19203	Puller — Flywheel	1
383	89838	Wrench — Spark Plug	1
422	223721	Clamp — Oil Filler Tube	1
523	490327	Cap and Dipstick — Oil Filler	1
524	68838	Seal — Filler Tube	1
525	280741	Tube — Oil Filler	1
552	231055	Bushing — Governor Crank (1/4" I.D.)	1
562	92613	Bolt — Governor Lever	1
592	231082	Nut — Hex., 10-24	1
614	93306	Cotter — Hair Pin	1
615	93307	Retainer — E-Ring	1
635	66538	Elbow — Spark Plug	1
657	93496	Screw — Sem	1
663	93572	Screw	1
741	262135	Gear — Timing	1
757	212359	Link — Counterweight	1
758	399891	Counterweight Assembly	1
759	298909	Pin — Counterweight	1
761	93875	Screw — Counterweight	1
842	270920	Seal — Oil Filler Cap	1
847	490474	Fill Group — Oil	1
851	221798	Terminal — Ignition Cable	1
869	261463	Seat — Intake Valve (Standard)	1
870	210940	Seat — Exhaust Valve (Std.)	1
871	261961	Guide — Exhaust Valve <b>Note: 231218 Guide — Intake Valve (Brass)</b> <b>See Repair Manual</b>	1
985	398525	Insulator Assembly	1
1005	280687	Fan — Flywheel	1
1006	223726	Retainer — Fan	1
1007	231531	Spacer — Clutch	1
1019	491255	Decal (Label) Kit	1
1020	262243	Eccentric	1
1021	94160	Pin — Eccentric	1

\* Included in Gasket Set — Part No. 490525.

# ENGINE BRIGGS & STRATTON MODEL NO. 253707-0175-01 (Continued) 12 H.P. REAR ENGINE RIDER ELECTRIC MODEL 56175

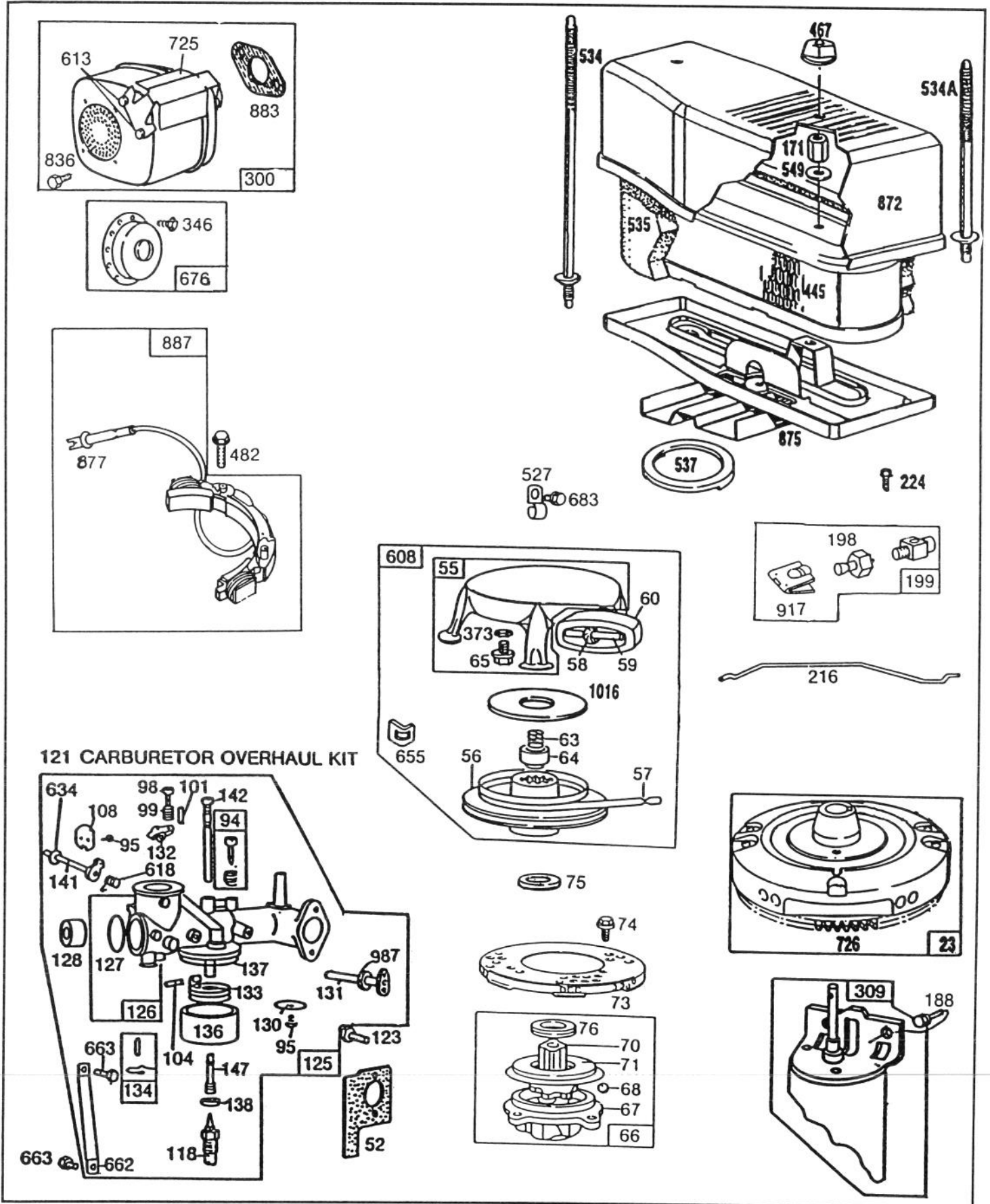



# ENGINE BRIGGS & STRATTON MODEL NO. 253707-0175-01 (Continued)

## 12 H.P. REAR ENGINE RIDER ELECTRIC MODEL 56175

Ref. No.	Part No.	Description	No. Used
23	399917	Flywheel and Ring Gear Assy. — Magneto	1
52	*270872	Gasket — Carburetor Mounting	1
55	393576	Housing — Rewind Starter (Includes 63" Rope)	1
56	295871	Pulley — Rewind Starter	1
57	490179	Spring — Rewind Starter	1
58	66884	Rope — Rewind Starter (63" long)	1
59	230228	Pin — Starter Grip	1
60	66728	Grip — Starter Rope	1
63	260414	Spring — Ratchet	1
64	230543	Adapter — Ratchet Spring	1
65	94128	Screw — Hex. Head Sem	1
66	399671	Clutch Assy. — Rewind Starter	1
67	394897	Housing — Starter Clutch	1
68	63770	Ball — Clutch	1
70	298799	Ratchet — Rewind Starter Clutch	1
71	221653	Washer — Retainer	1
73	223859	Screen — Rotating	1
74	93042	Screw — Sem	1
75	220865	Washer — Spring	1
76	68238	Washer — Ratchet Sealing	1
94	†292681	Valve Assbly. — Carburetor Idle	1
95	93499	Screw — Throttle and Choke Valve Mtg. Sem	1
98	91920	Screw — Machine, Fill. Hd. 8-23 x 5/8"	1
99	26157	Spring — Throttle Adjustment	1
101	93043	Pin — Throttle Stop	1
104	†230896	Pin — Float Hinge	1
108	222010	Valve Choke	1
118	†396568	Valve — Needle	1
121	394698	Carburetor Overhaul Kit	1
123	93357	Screw — Carburetor Mtg.	1
125	491031	Carburetor Assembly	1
126	490473	Body Assembly — Carburetor	1
127	†221997	Plug — Welch	1
128	211960	Venturi — Carburetor	1
130	222433	Valve — Throttle	1
131	491006	Shaft and Lever — Throttle	1
132	211712	Stop — Throttle	1
133	299707	Float — Carburetor	1
134	†394681	Valve — Fuel Inlet	1
136	221995	Bowl — Float	1
137	†270511	Gasket — Float Bowl	1
138	†222014	Washer — Float Bowl	1

Ref. No.	Part No.	Description	No. Used
141	390684	Shaft and Lever — Choke	1
142	†299740	Nozzle — Carburetor	1
147	†231323	Screw — Nozzle	1
171	231532	Nut — Air Cleaner Mtg.	1
188	93535	Screw — Sem	1
198	293934	Valve — Fuel Shut-Off	1
199	399949	Connector — Fuel Pipe	1
216	261610	Link — Choke	1
224	94018	Screw — Sem	1
300	491413	Muffler — Exhaust	1
309		Motor Starting (12 Volt)	1
		<b>See Chart for Replacement Parts for Starting Motors.</b>	
346	93705	Screw — Sem	1
373	92987	Nut — Hex.	1
445	399806	Cartridge — Air Cleaner	1
467	212706	Knob — Air Cleaner	1
482	93621	Screw — Sem	1
527	221428	Clamp	2
534	94248	Stud — Air Cleaner	1
534A	94246	Stud — Air Cleaner	1
535	271962	Element — Air Cleaner	1
537	270853	Gasket — Air Cleaner	1
549	94249	Washer — Air Cleaner	1
608	390391	Starter Assy. — Rewind	1
613	93927	Screw — Hex. Hd.	1
618	261116	Spring — Choke Return	1
634	270382	Washer — Choke Shaft	1
655	222598	Anchor — Spring	1
662	222311	Bracket — Carburetor	1
663	93572	Screw	1
676	396903	Deflector — Muffler	1
683	93572	Screw	1
725	223023	Shield — Muffler	1
726	392134	Gear — Ring (Includes Mounting Parts)	1
836	93559	Screw — Hex. Head	1
872	223700	Cover — Air Cleaner	1
875	490332	Body — Air Cleaner	1
877	393814	Diode and Connector Assy. (D.C.)	1
883	270917	Gasket — Exhaust Pipe	1
887	391529	Stator Assembly — Alternator (D.C.)	1
917	223271	Valve Handle — Fuel Shut-Off	1
987	398970	Seal — Throttle Shaft	1
1016	490817	Spacer	1

\* Included in Gasket Set — Part No. 490525.

† Included in Carburetor Overhaul Kit — Part No. 394698.

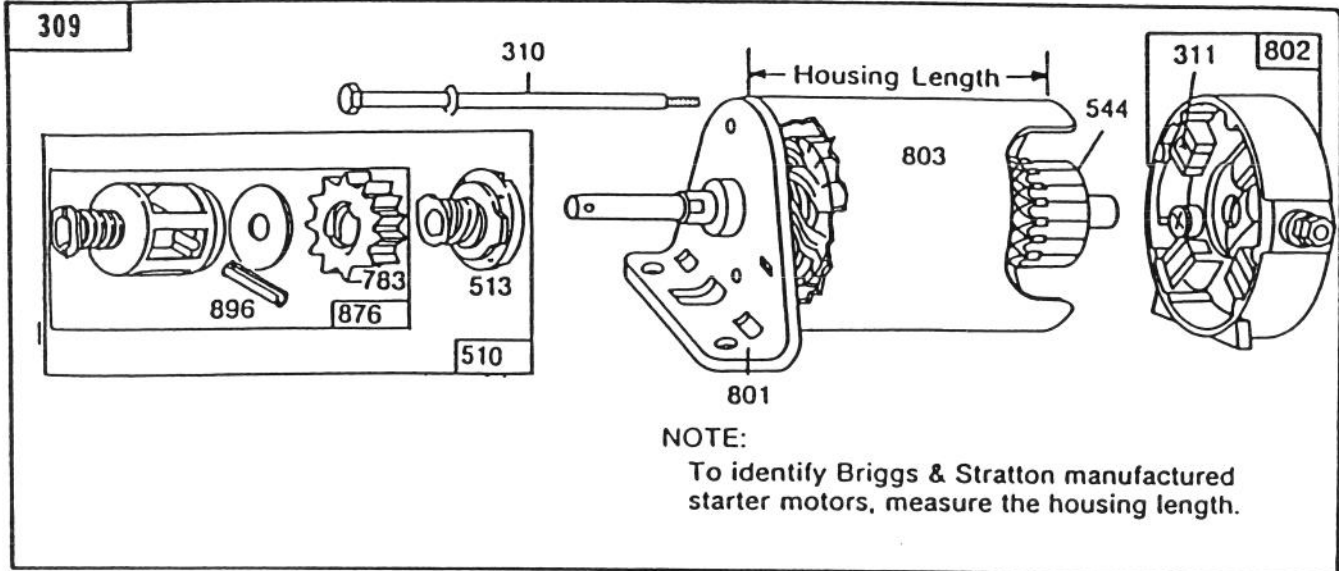

## BRIGGS & STRATTON STARTER MOTOR ASSEMBLY 12 H.P. REAR ENGINE RIDER MODEL 56175

Ref. No.	Part No.	Description	No. Used
309	490420	Motor and Drive Assembly	1
310	94004	Thru Bolt Assembly	1
311	395538	Brush Assembly	1
510	490421	Drive Assembly (Incl. Ref. #513)	1
513	398003	Clutch Assembly	1
544	391160	Armature Assembly	1

Ref. No.	Part No.	Description	No. Used
783	280104	Gear	1
801	394857	End Cap Assembly Drive	1
802	395537	End Cap Assembly Commutator (Incl. Ref. #311)	1
803	394544	Housing Assembly	1
876	490467	Retainer Kit	1
896	94288	Roll Pin	1