



Tree Forks Compact Utility Loaders

Model No. 22438 - 240000001 and up.

Parts Catalog

Ordering Replacement Parts

To order replacement parts, please supply the part number, the quantity, and the description of each part desired.

Understanding Reference Numbers

Each identified part in an illustration has a reference number. The reference number for a part also appears in the parts list, along with other information about the part.

This catalog uses two special reference number formats, one to indicate parts in a service assembly and another to indicate the quantity of a given part in an illustration.

Service Assembly Reference Numbers

Parts in service assemblies have reference numbers in the form a:b. The a represents the reference number of the entire service assembly and the b represents a sequential number unique to each part within the service assembly.

For example, a wheel assembly might be identified by reference number 6, the tire by 6:1, the valve by 6:2, and the wheel by 6:3. When you order the assembly identified by reference number 6, you receive all parts identified by reference numbers 6:1, 6:2, and 6:3. However, you may also order any part individually. Reference numbers of this type appear in illustrations and in part lists.

Reference Numbers Indicating Quantity

In an illustration, if a reference number indicates more than one part, the reference number has the form nX y. The n represents the quantity of the part, the X is the multiplication symbol, and the y represents the reference number.

For example, in an illustration, the reference number 2X 37 means that two of the parts identified by reference number 37 are indicated.

Contents

Description	Page	Description	Page
Tree Fork Assembly 3	Attachments and Accessories List 5
Hydraulic Cylinder Assembly No. 110-0079 4		

Part Description Abbreviations

Part descriptions in this catalog may include the following abbreviations.

AR.	as required	INC.	incorporated
ASM.	assembly	LH.	left hand
BBC.	blade brake clutch	NI.	nylon insert
CARR.	carriage	NPTF.	national pipe thread fine
DEG.	degrees	PFH.	phillips flat head
EXT.	external	PPH.	phillips pan head
FH.	flat head	PPHTF.	phillips pan head thread forming
GA.	gauge	PRH.	phillips round head
HF.	hex flange	PTH.	phillips truss head
HH.	hex head	PTO.	power-take-off
HHF.	hex head flange	RH.	right hand
HHFTF.	hex head flange thread forming	ROPS.	roll-over-protection-system
HJ.	hex jam	SFH.	slotted fillister head
HLH.	hex lag head	SHH.	slotted hex head
HOC.	height-of-cut	SHWH.	slotted hex washer head
HSBH.	hex socket button head	SPH.	slotted pan head
HSFH.	hex socket flat head	SQH.	square head
HS.	hex socket head	SRH.	slotted round head
HWH.	hex washer head	STD.	standard
HWHTF.	hex washer head thread forming	TAP.	self tapping
HYD.	hydraulic	TTH.	torx truss head

Footnotes

- Not serviced separately

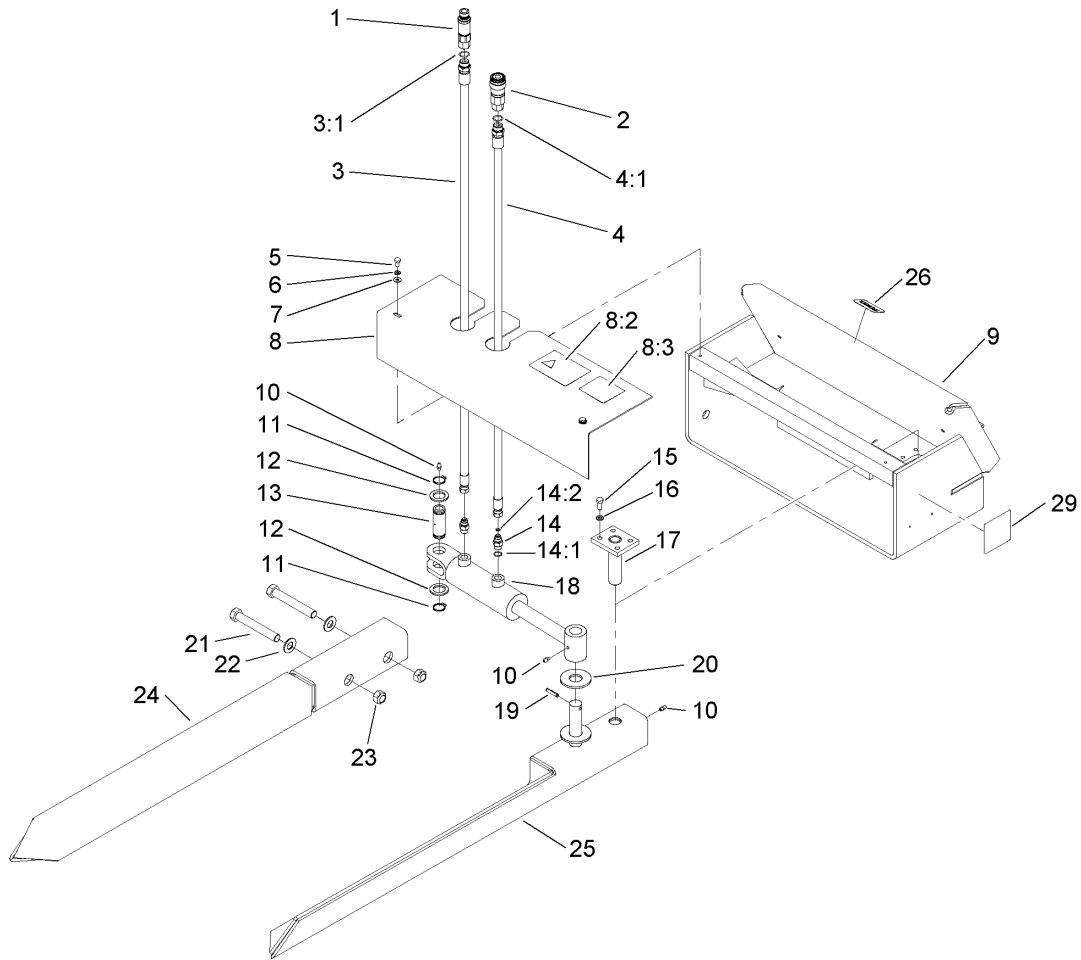

Tree Fork Assembly

Ref	Part No.	Qty.	Description	Ref	Part No.	Qty.	Description
1	110-0077	1	Male Coupler ASM	19	32121-9	1	Pin-Roll, Slotted
2	110-0078	1	Female Coupler ASM	20	3256-10	1	Washer-Flat
3	110-0075	1	HYD Hose ASM	21	327-23	2	Screw-HH
3:1	237-79	1	O-Ring	22	3256-27	2	Washer-Flat
4	110-0076	1	HYD Hose ASM	23	105-0369	2	Nut-Crownlock
4:1	237-79	1	O-Ring	24	99-1682	1	Arm-Pivot, RH
5	321-2	2	Screw-HH	25	99-1683	1	Arm-Pivot, LH
6	3253-3	2	Washer-Lock	26	98-3206	1	Decal
7	3256-1	2	Washer-Flat	29	98-3269	1	Decal
8	110-0083	1	Cover Plate ASM				
8:2	100-4690	1	Decal-Rating, Load				
8:3	100-4650	1	Decal-Warning				
9		1	Frame ASM				
10	302-5	3	Fitting-Grease				
11	32151-36	2	Ring-Retaining				
12	256-115	2	Washer-Thrust				
13	110-0085	1	Pin-Pivot, Cylinder				
14	103-2156	2	Fitting-Straight				
14:1	1-603921	1	O-Ring				
14:2	103-1020	1	O-Ring				
15	322-3	4	Screw-HH				
16	3253-4	4	Washer-Lock				
17	99-1672	1	Pin				
18	110-0079	1	HYD Cylinder ASM				

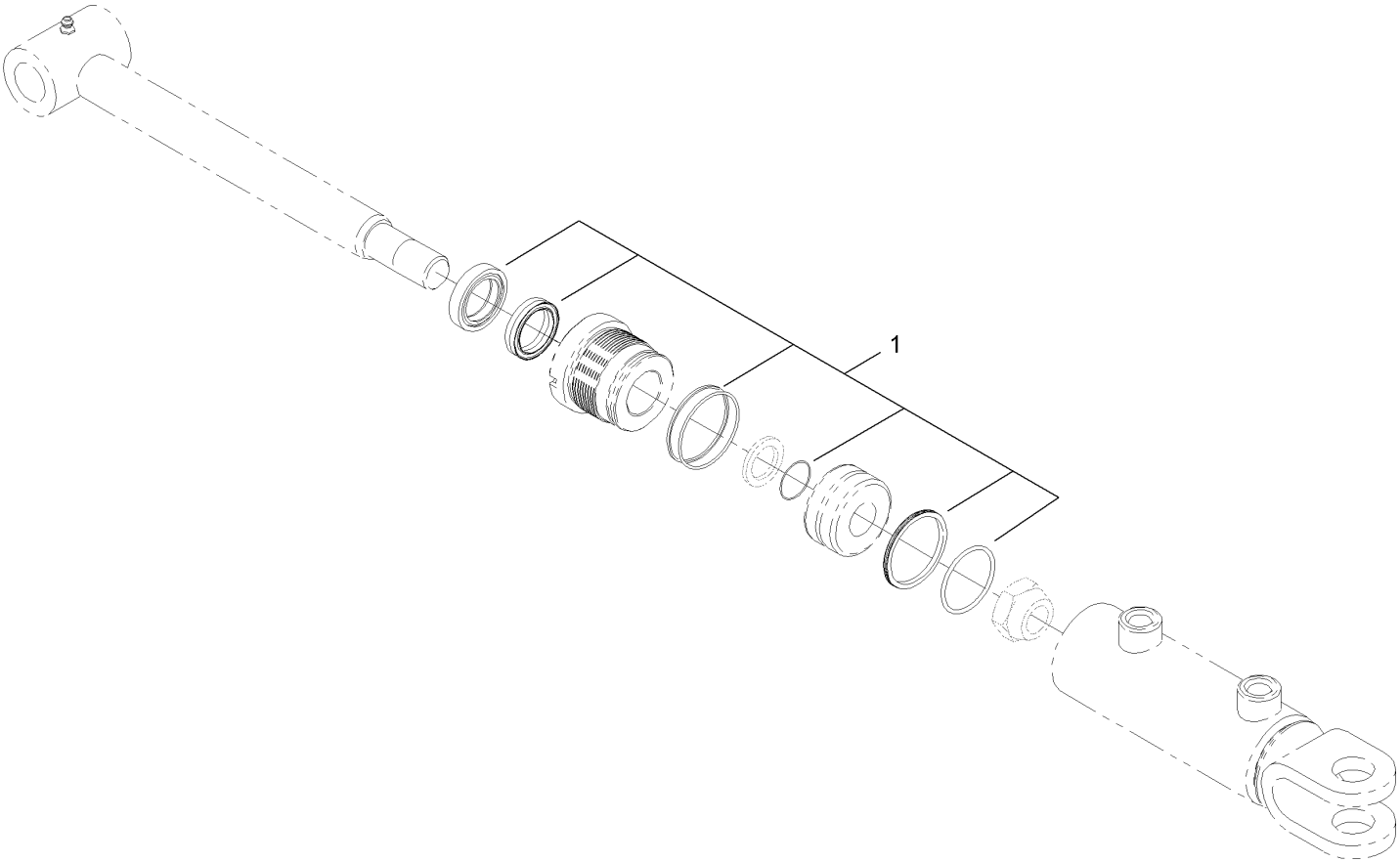

Hydraulic Cylinder Assembly No. 110-0079

Ref	Part No.	Qty.	Description
1	110-0080	1	Seal Kit

Ref	Part No.	Qty.	Description

Attachments and Accessories

For 22438 - Tree Forks, Compact Utility Loaders

Product Name	Model/Part
NPT Flush Face Adapter Kit	100-4745
Coupler Kit	106-7695

NOTES

NOTES

