



## Auger Head and Universal Swivel Auger Head Compact Utility Loaders

Model No. 22802 - 230000001 and up.

Model No. 22803 - 230000001 and up.

## Parts Catalog

---

### Ordering Replacement Parts

To order replacement parts, please supply the part number, the quantity, and the description of each part desired.

### Understanding Reference Numbers

Each identified part in an illustration has a reference number. The reference number for a part also appears in the parts list, along with other information about the part.

This catalog uses two special reference number formats, one to indicate parts in a service assembly and another to indicate the quantity of a given part in an illustration.

### Service Assembly Reference Numbers

Parts in service assemblies have reference numbers in the form a:b. The a represents the reference number of the entire service assembly and the b represents a sequential number unique to each part within the service assembly.

For example, a wheel assembly might be identified by reference number 6, the tire by 6:1, the valve by 6:2, and the wheel by 6:3. When you order the assembly identified by reference number 6, you receive all parts identified by reference numbers 6:1, 6:2, and 6:3. However, you may also order any part individually. Reference numbers of this type appear in illustrations and in part lists.

### Reference Numbers Indicating Quantity

In an illustration, if a reference number indicates more than one part, the reference number has the form nX y. The n represents the quantity of the part, the X is the multiplication symbol, and the y represents the reference number.

For example, in an illustration, the reference number 2X 37 means that two of the parts identified by reference number 37 are indicated.

# Contents

Description	Page	Description	Page
Auger Head Assembly	..... 3	Hydraulic Motor Assembly No. 98-8256 and 100-4657	..... 5
Universal Auger Head Assembly	..... 4	Planetary Gear Assembly No. 105-0311-03	..... 6
		Attachments and Accessories List	..... 7

## Part Description Abbreviations

Part descriptions in this catalog may include the following abbreviations.

AR. .... as required	INC. .... incorporated
ASM. .... assembly	LH. .... left hand
BBC. .... blade brake clutch	NI. .... nylon insert
CARR. .... carriage	NPTF. .... national pipe thread fine
DEG. .... degrees	PFH. .... phillips flat head
EXT. .... external	PPH. .... phillips pan head
FH. .... flat head	PPHTF. .... phillips pan head thread forming
GA. .... gauge	PRH. .... phillips round head
HF. .... hex flange	PTH. .... phillips truss head
HH. .... hex head	PTO. .... power-take-off
HHF. .... hex head flange	RH. .... right hand
HHFTF. .... hex head flange thread forming	ROPS. .... roll-over-protection-system
HJ. .... hex jam	SFH. .... slotted fillister head
HLH. .... hex lag head	SHH. .... slotted hex head
HOC. .... height-of-cut	SHWH. .... slotted hex washer head
HSBH. .... hex socket button head	SPH. .... slotted pan head
HSFH. .... hex socket flat head	SQH. .... square head
HSH. .... hex socket head	SRH. .... slotted round head
HWH. .... hex washer head	STD. .... standard
HWHTF. .... hex washer head thread forming	TAP. .... self tapping
HYD. .... hydraulic	TTH. .... torx truss head

## Footnotes

❶ Not illustrated

❷ Not serviced separately

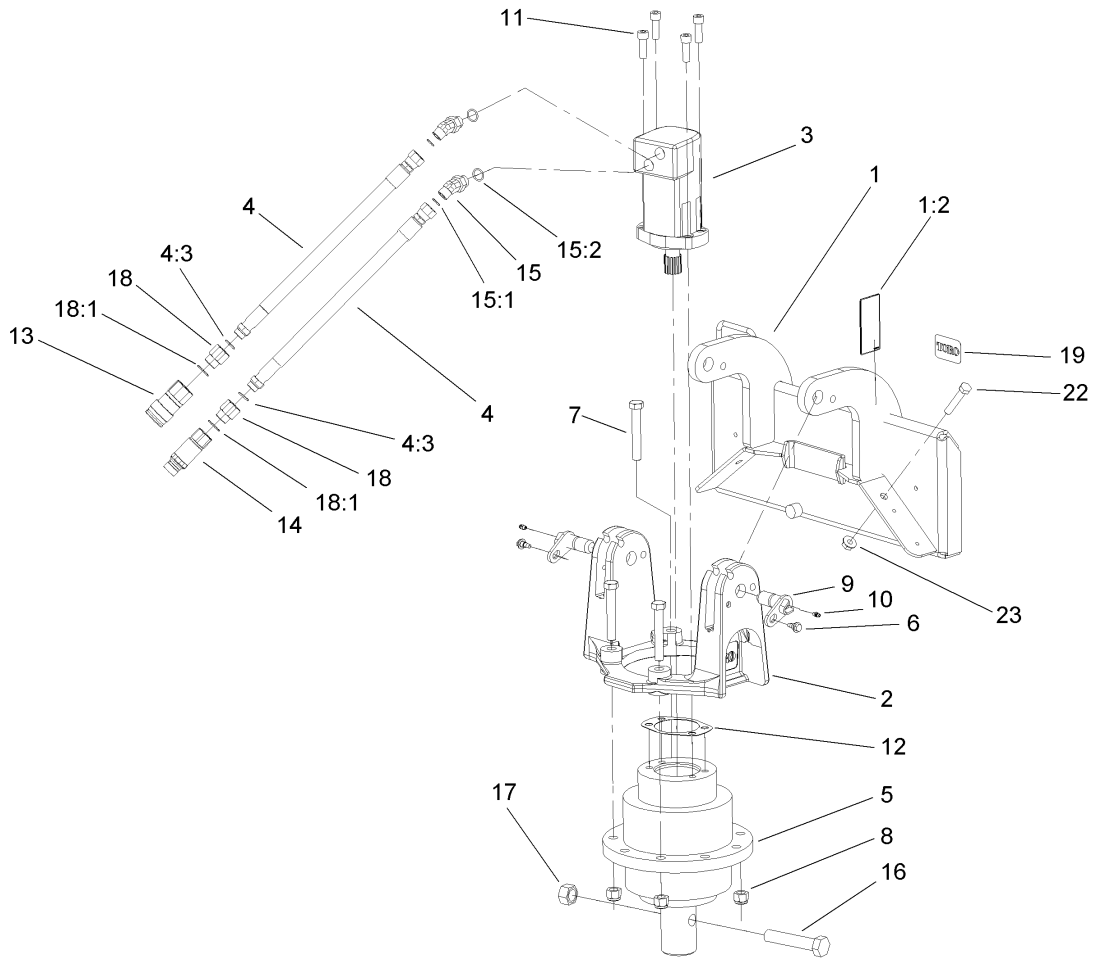

## Auger Head Assembly

Ref	Part No.	Qty.	Description	Ref	Part No.	Qty.	Description
1	105-0322	1	Auger Mount ASM	18:1	237-80	1	O-Ring
1:2	105-0326	2	Decal-Danger	19	92-7981	1	Decal
2	105-0316-03	1	Yoke	22	325-11	1	Screw-HH
3	98-8256	1	Hydraulic Motor ASM	23	32128-49	1	Nut-HHF
4	105-0321	2	HYD Hose ASM				
4:3	237-79	1	O-Ring				
5	105-0311-03	1	Drive-Planetary				
6	99-5105	2	Bolt-Shoulder				
7	327-16	4	Screw-HH				
8	3296-53	4	Nut-Lock, NI				
9	99-1414	2	Pin-Pivot				
10	302-5	2	Fitting-Grease				
11	3274-4	4	Screw-HSH				
12	99-5032	1	Gasket				
13	104-6134	1	Coupler-Face, Flush				
●13:1	105-8396	1	Seal Kit				
14	100-4701	1	Nipple-Connect, Pressure				
●14:1	100-6120	1	Seal Kit				
15	340-89	2	Fitting-HYD, 45 DEG				
15:1	237-30	1	O-Ring				
15:2	237-80	1	O-Ring				
16	98-9062	1	Screw				
17	3217-15	1	Nut-Hex				
18	100-4617	2	Adapter-HYD				

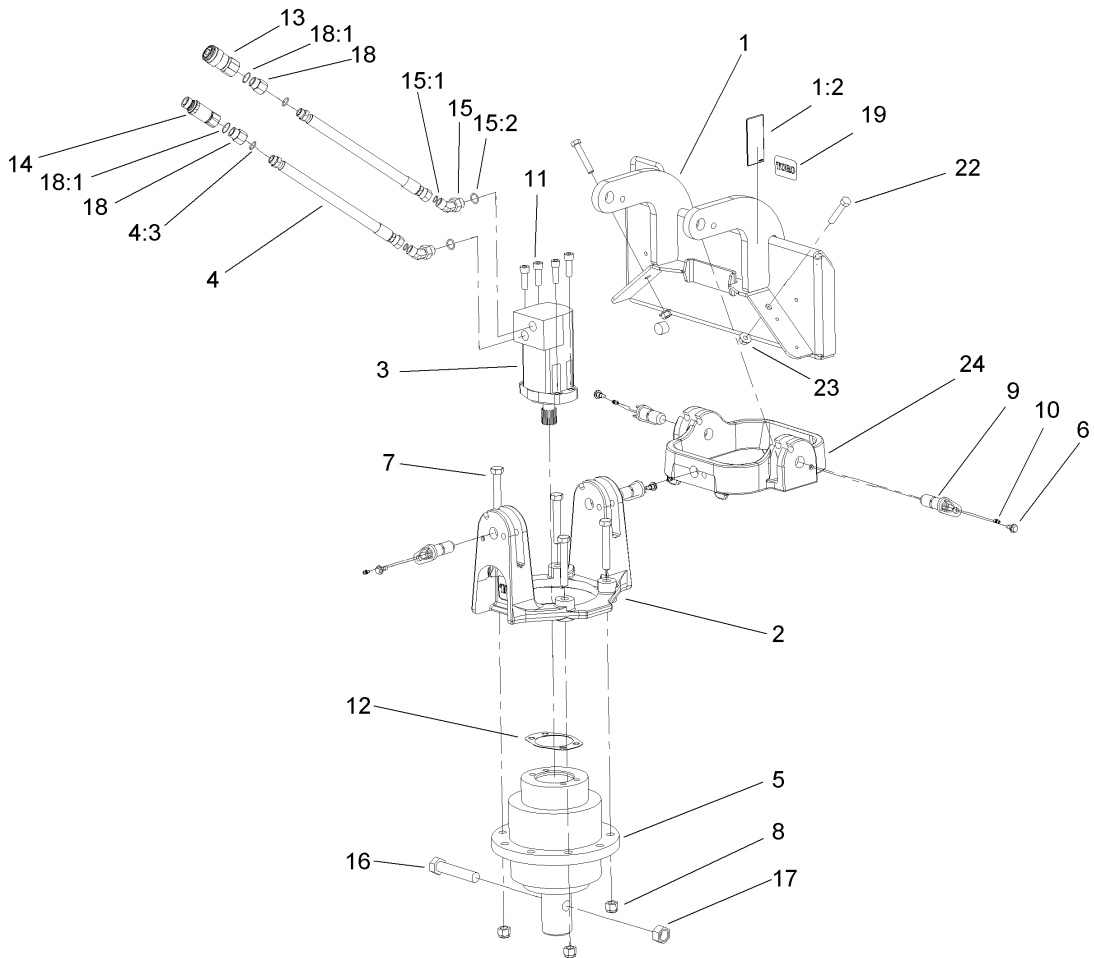

## Universal Auger Head Assembly

Ref	Part No.	Qty.	Description
1	105-0329	1	Auger Mount ASM
1:2	105-0326	2	Decal-Danger
2	105-0316-03	1	Yoke
3	100-4657	1	Hydraulic Motor ASM
4	105-0321	2	HYD Hose ASM
4:3	237-79	1	O-Ring
5	105-0311-03	1	Drive-Planetary
6	99-5105	4	Bolt-Shoulder
7	327-16	4	Screw-HH
8	3296-53	4	Nut-Lock, NI
9	99-1414	4	Pin-Pivot
10	302-5	4	Fitting-Grease
11	3274-4	4	Screw-HSH
12	99-5032	1	Gasket
13	104-6134	1	Coupler-Face, Flush
13:1	105-8396	1	Seal Kit
14	100-4701	1	Nipple-Connect, Pressure
14:1	100-6120	1	Seal Kit
15	340-89	2	Fitting-HYD, 45 DEG
15:1	237-30	1	O-Ring
15:2	237-80	1	O-Ring
16	98-9062	1	Screw
17	3217-15	1	Nut-Hex
18	100-4617	2	Adapter-HYD

Ref	Part No.	Qty.	Description
18:1	237-80	1	O-Ring
19	92-7981	1	Decal
22	325-11	2	Screw-HH
23	32128-49	2	Nut-HHF
24	105-0315-03	1	Swivel

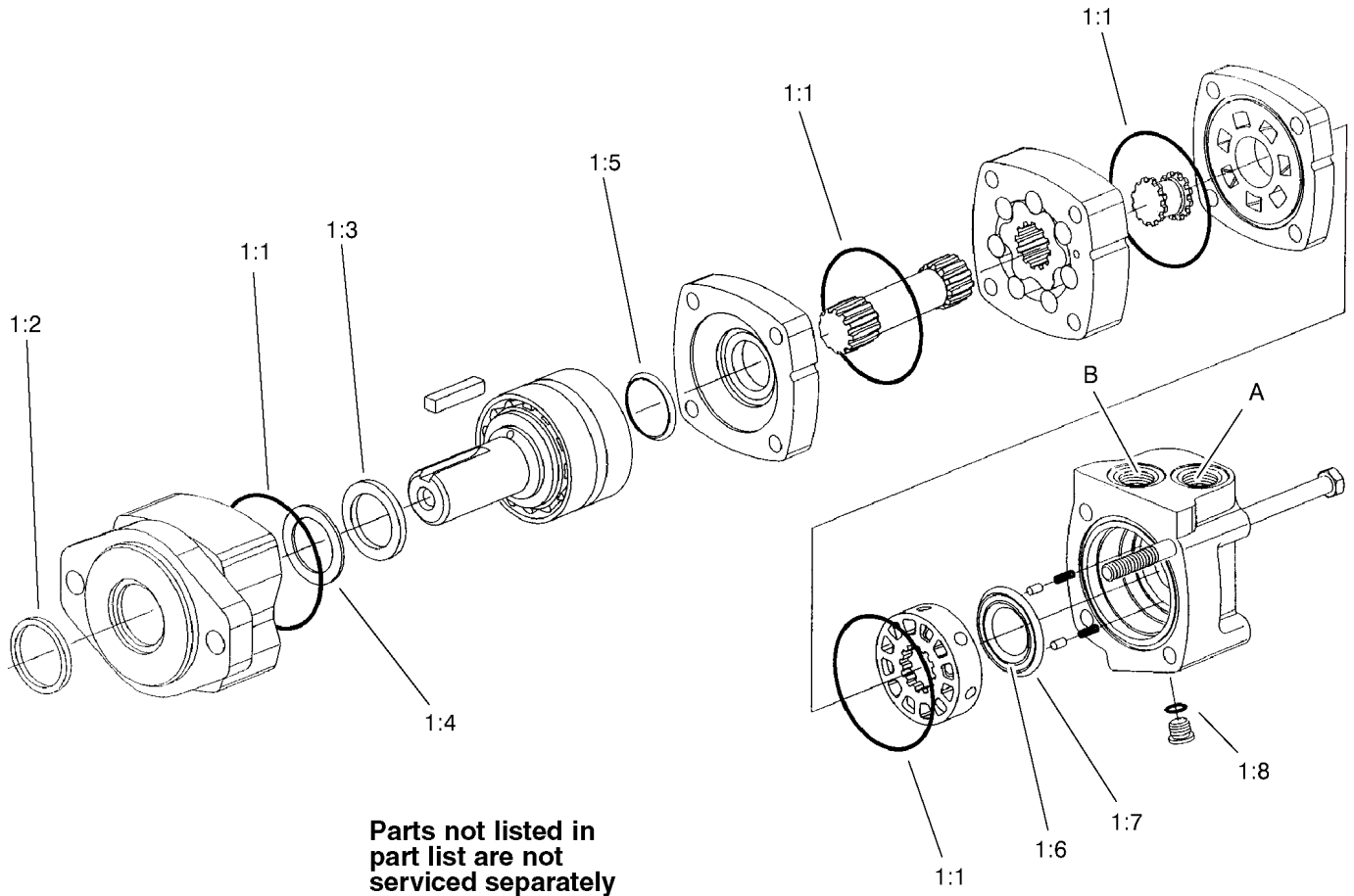

## Hydraulic Motor Assembly No. 98-8256 and 100-4657

Ref	Part No.	Qty.	Description
1	56-6890	1	Kit-Seal
②1:1		4	O-Ring
②1:2		1	Seal-Exclusion, Shaft
②1:3		1	Seal-Shaft
②1:4		1	Ring-Back-Up
②1:5		1	Seal-Face, Shaft
②1:6		1	Seal-Face, Inner
②1:7		1	Seal-Face, Outer
②1:8		1	O-Ring

--	--	--	--

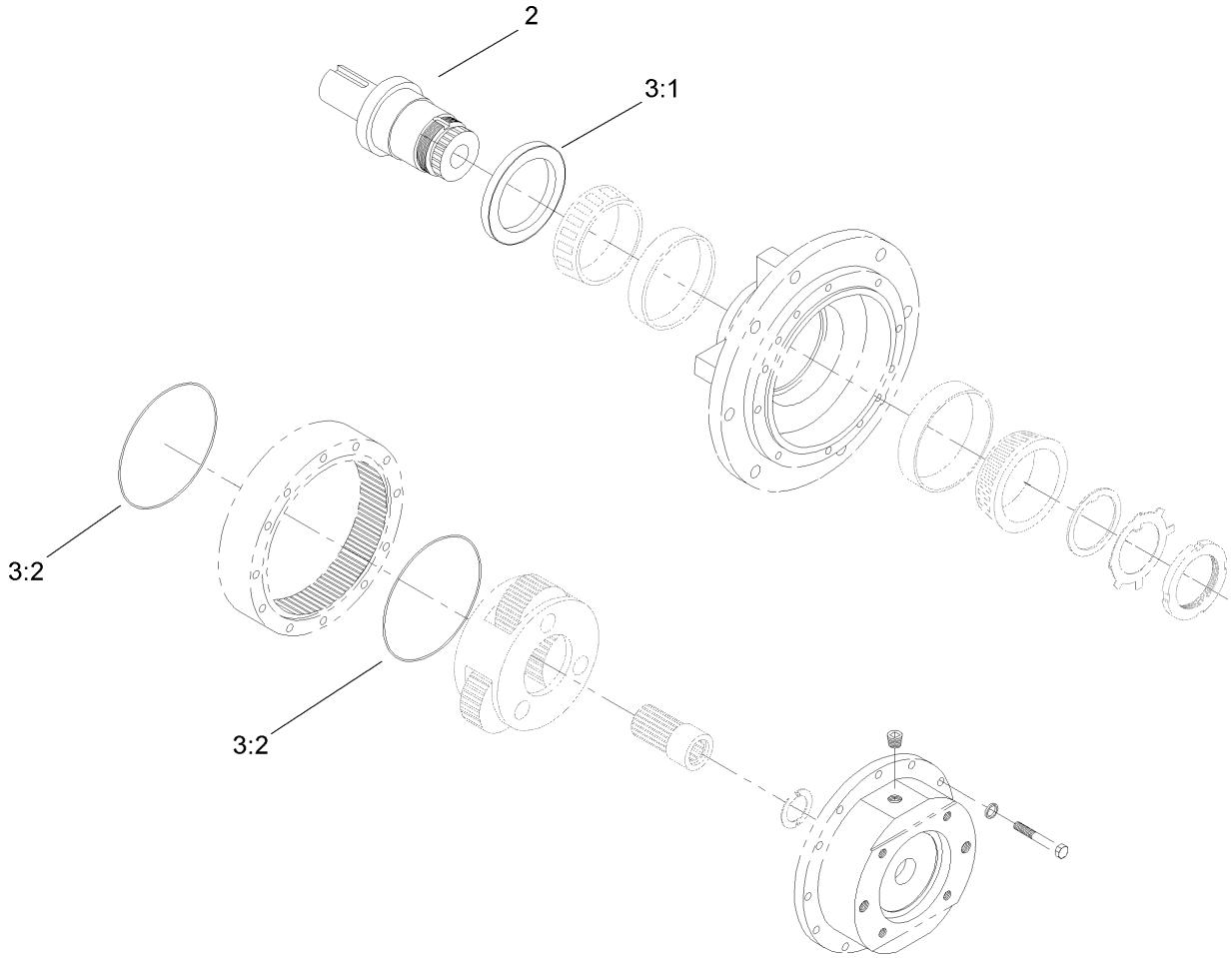

### Planetary Gear Assembly No. 105-0311-03

Ref	Part No.	Qty.	Description
2	104-6091	1	Shaft-Output
3	104-6092	1	Kit-Seal
3:1		1	Seal-Shaft
3:2		2	O-Ring

--	--	--	--

## Attachments and Accessories

### For 22802 - Auger Head, Compact Utility Loaders

Product Name	Model/Part
6" Auger .....	22402
9" Auger .....	22403
12" Auger .....	22404
15" Auger .....	22405
18" Auger .....	22406
24" Auger .....	22407
30" Auger .....	22408
Cement Bowl .....	22442
12" Auger Extension .....	22448
24" Auger Extension .....	22449
Capstan Adaptor .....	22450
Screw Anchor Adaptor .....	22451
Rock Auger .....	22454

## Attachments and Accessories

### For 22803 - Universal Swivel Auger Head, Compact Utility Loaders

Product Name	Model/Part
6" Auger .....	22402
9" Auger .....	22403
12" Auger .....	22404
15" Auger .....	22405
Cement Bowl .....	22442
12" Auger Extension .....	22448
24" Auger Extension .....	22449
Capstan Adaptor .....	22450
Screw Anchor Adaptor .....	22451
Rock Auger .....	22454

