



Consumer Products

Power Max™

Snowthrower

Service Manual



ABOUT THIS MANUAL

This service manual was written expressly for Toro service technicians. The Toro Company has made every effort to make the information in this manual complete and correct.

Basic shop safety knowledge and mechanical/electrical skills are assumed. The Table of Contents lists the systems and the related topics covered in this manual.

For information specific to the engines used on this unit, refer to the engine chapter of this book.

Power Max model years 2004 - 2005 are covered in this manual. The manual may also be specified for use on later model products.

We are hopeful that you will find this manual a valuable addition to your service shop. If you have questions or comments regarding this manual, please contact us at the following address:

**The Toro Company
Consumer Service Department
8111 Lyndale Avenue South
Bloomington, MN 55420-1196**

The Toro Company reserves the right to change product specifications or this manual without notice.

TABLE OF CONTENTS

SAFETY INFORMATION

Safety Information	1 - 1
------------------------------	-------

SPECIFICATIONS

Specifications	2 - 1
Torque Specifications	2 - 3

ENGINE

Service Information	3 - 1
Servicing the R tek Engine	3 - 1
Primer Button	3 - 2
Ignition Switch	3 - 2
Fuel Tank, Fuel Line, Fuel Filter	3 - 3
Prime Line Routing	3 - 3
Engine Shroud Assembly	3 - 3

CONTROLS

Quick Stick	4 - 1
Operation	4 - 1
Removal	4 - 1
Disassembly	4 - 3
Reassembly	4 - 4
Installation	4 - 5
Control Interlock	4 - 5
Control Operation, Replacement & Adjustment	4 - 7
Deflector Cable	4 - 7
Deflector Cable Adjustment	4 - 8
Shift Lever	4 - 8
Shift Rod Adjustment	4 - 8
Auger Control	4 - 9
Auger Cable Adjustment	4 - 9
Auger Brake Adjustment	4 - 10
Traction Control	4 - 10
Traction Cable Adjustment	4 - 11
Replace & Adjust Wheel Clutch Cables	4 - 11

TABLE OF CONTENTS

BELT REPLACEMENT

Auger Belt	5 - 1
Traction Belt	5 - 2

AUGER HOUSING

Auger Housing Components	6 - 1
Skids	6 - 1
Scraper	6 - 1
Fixed Scraper	6 - 1
Scraper Replacement	6 - 1
Adjusting the Skids and Scraper - Fixed	6 - 2
Pivoting Scraper	6 - 2
Scraper Replacement & Adjustment	6 - 2
Adjusting the Skids and Scraper - Pivoting	6 - 3

AUGER GEARBOX

Auger Gearbox Removal Primary Method	7 - 1
Separating the Auger & Traction Assemblies	
Secondary Method	7 - 4
Gearbox Installation	7 - 5
Auger Gearbox Repair	7 - 6
Lubrication	7 - 6
Gearbox Disassembly & Repair	7 - 6
Failure Analysis	7 - 7
Gearbox Assembly	7 - 8

NON-WHEEL CLUTCH TRACTION DRIVE SYSTEM

General Description	8 - 1
Disassembly	8 - 1
Reassembly	8 - 6

WHEEL CLUTCH TRACTION DRIVE SYSTEM

General Description	9 - 1
Disassembly	9 - 1
Drive System Reassembly	9 - 9

TABLE OF CONTENTS

WHEEL CLUTCH TRACTION DRIVE SYSTEM (cont.)

Wheel Clutch Disassembly	9 - 17
Wheel Clutch Reassembly	9 - 20

DISCHARGE CHUTE

Chute & Auger Cover Removal	10 - 1
Chute Gears	10 - 4
Operation	10 - 4
Disassembly	10 - 4
Assembly	10 - 6

ELECTRICAL

Electric Start System	11 - 1
Lighting	11 - 1
Ignition Switch	11 - 1

WHEELS and TIRES

Wheels	12 - 1
Tires	12 - 1

SAFETY INFORMATION

General Information



This symbol means **WARNING** or **PERSONAL SAFETY INSTRUCTION** - read the instruction because it has to do with your safety. Failure to comply with the instruction may result in personal injury or even death.

This manual is intended as a service and repair manual only. The safety instructions provided herein are for troubleshooting, service, and repair of the Power Max™ snowthrower. The Power Max™ snowthrower operator's

manual contains safety information and operating tips for safe operating practices. Operator's manuals are available through your parts source or:

**The Toro Company
Publications Department
8111 Lyndale Avenue South
Bloomington, MN 55420**

Think Safety First

Avoid unexpected starting of engine...

Always turn off the engine and disconnect the spark plug wire(s) before cleaning, adjusting, or repair.

Avoid lacerations and amputations...

Stay clear of all moving parts whenever the engine is running. Treat all normally moving parts as if they were moving whenever the engine is running or has the potential to start.

Avoid burns...

Do not touch the engine, muffler, or other components which may increase in temperature during operation, while the unit is running or shortly after it has been running.

Avoid fires and explosions...

Avoid spilling fuel and never smoke while working with any type of fuel or lubricant. Wipe up any spilled fuel or oil immediately. Never remove the fuel cap or add fuel when the engine is running. Always use approved, labeled containers for storing or transporting fuel and lubricants.

Avoid asphyxiation...

Never operate an engine in a confined area without proper ventilation.

Avoid injury due to inferior parts...

Use only original equipment parts to ensure that important safety criteria are met.

Avoid injury to bystanders...

Always clear the area of bystanders before starting or testing powered equipment.

Avoid injury due to projectiles...

Always clear the area of sticks, rocks, or any other debris that could be picked up and thrown by the powered equipment.

Avoid modifications...

Never alter or modify any part unless it is a factory approved procedure.

THIS PAGE INTENTIONALLY LEFT BLANK

SPECIFICATIONS

Engine RPM 2-cycle	4,000 +250 -250 RPM
4-cycle	3,300 +150 -150 RPM
Auger 26"	26" (66cm) Wide & 21.5" (54.6cm) High
28"	28" (71cm) Wide & 21.5" (54.6cm) High
Auger Speed	123 RPM @ engine RPM listed above
Impeller	12" Dia. (30.5cm)
Impeller Speed	1228 RPM @ engine RPM listed above
Chute Rotation	200 degrees
Deflector tilt angle	70 degrees
Tires Semi pneumatic	15x500x6
Pressure	17-20 psi (116-137kPa)
Ground speeds Forward	0.7, 1.1, 1.5, 1.9, 2.3, 2.7 mph (1.1, 1.8, 2.4, 3.0, 3.7, 4.3 kph)
Reverse	1.0 & 1.6 mph (1.6 & 2.5 kph)
Height	44.5" (113cm) Approx.
Overall Width	27.5" (69.8cm) and 29.5" (74.9cm)
Length	62" (157cm)
Weight	724= 210 lbs (462kg) 826= 238 lbs (526kg) 828 & 1028= 245 lbs (539kg) 1128= 253 lbs (556kg)
Fuel Capacity 2 cycle engine	1.46 US qts (1.38l)
4 cycle engine	4 US qts (3.8l)

Fuel/oil 2-cycle Fuel	Unleaded regular grade gasoline mixed at a ratio of 50:1 2.6 oz. (80ml) oil / 1 US gallon (3.8l) gasoline.
2-cycle Required oil	Toro 2 cycle oil or any 2-cycle oil that is NMMA TCW3 (ISO E GD) certified as an acceptable substitute.
4-cycle Fuel	Unleaded regular grade gasoline (do not mix with oil).
4-cycle Oil	automotive detergent oil with a service classification of SH or higher Maximum capacity 26 oz. (770ml)

The recommended weight varies with the outside temperature

For Temps Above 32° F (0° C)	use SAE 30W
For Temps Between 0° F and 32° F (-18° C to 0° C)	use SAE 5W30 or SAE 10W
For Temps Below 0° F (-18° C)	use SAE 0W30
Auger Gearbox lubricant*	SAE 90 gear oil with a rating of GL5 or higher

*A multi weight may be used such as 85-120 as long as it meets the GL rating. Place the unit on level ground and fill to the fill/check plug. Maximum capacity 4 oz (118ml).

SPECIFICATIONS

The following parts should be lightly coated with an anti-seize compound when assembling after making repairs.

1. The impeller shaft, before installing the impeller pulley.
2. The engine crankshaft before installing the engine pulley.
3. The full length of the auger shaft before installing the augers.
4. The outer 5" (12.7cm) of the axle before installing the wheels.

Accessories

- Drift Breaker
- Tire Chains
- Snow Cab
- Weight Kit (Required with Cab)

SPECIFICATIONS

Torque Specifications

Recommended fastener torque values are listed in the following tables. For critical applications, as determined by Toro, either the recommended torque or a torque that is unique to the application is clearly identified and specified in the service manual.

These torque specifications for the installation and tightening of fasteners shall apply to all fasteners which do not have a specific requirement identified in the service manual. The following factors shall be considered when applying torque: cleanliness of the fastener, use of a thread sealant (Loctite), degree of lubrication on the fastener, presence of a prevailing torque feature, hardness of the surface underneath of the fastener's head, or similar condition which affects the installation.

As noted in the following tables, torque values should be **reduced by 25% for lubricated fasteners** to achieve the similar stress as a dry fastener. Torque values may also have to be reduced when the fastener is threaded into aluminum or brass. The specific torque value should be determined based on the aluminum or brass material strength, fastener size, length of thread engagement, etc.

The standard method of verifying torque shall be performed by marking a line on the fastener (head or nut) and mating part, then back off fastener 1/4 of a turn. Measure the torque required to tighten the fastener until the lines match up.

Fastener Identification

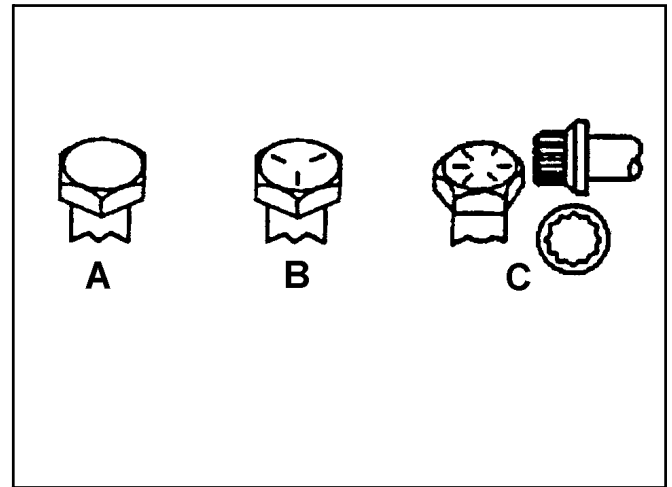

Figure 1

Inch Series Bolts and Screws	
(A) Grade 1 (B) Grade 5	(C) Grade 8

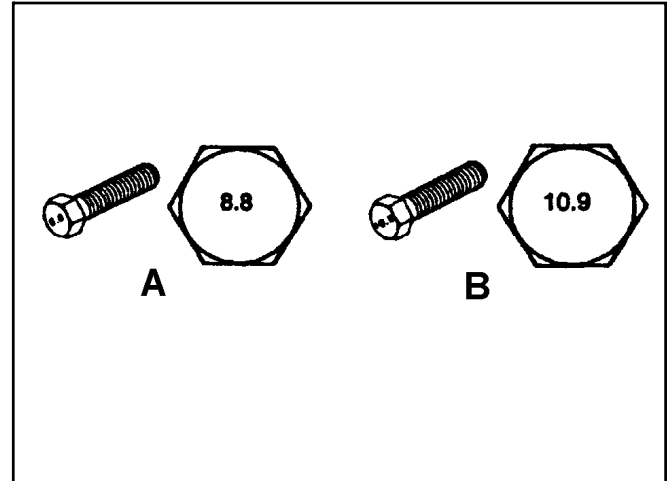

Figure 2

Metric Bolts and Screws	
(A) Class 8.8	(B) Class 10.9

SPECIFICATIONS

Standard Torque for Dry, Zinc Plated, and Steel Fasteners (Inch Series)

Thread Size	Grade 1, 5, & 8 with Thin Height Nuts	SAE Grade 1 Bolts, Screws, Studs, & Sems with Regular Height Nuts (SAE J995 Grade 2 or Stronger Nuts)		SAE Grade 5 Bolts, Screws, Studs, & Sems with Regular Height Nuts (SAE J995 Grade 2 or Stronger Nuts)		SAE Grade 8 Bolts, Screws, Studs, & Sems with Regular Height Nuts (SAE J995 Grade 2 or Stronger Nuts)	
	In-lb	In-lb	N-cm	In-lb	N-cm	In-lb	N-cm
# 6 - 32 UNC	10 ± 2	13 ± 2	147 ± 23	15 ± 2	170 ± 20	23 ± 2	260 ± 20
# 6 - 40 UNF				17 ± 2	190 ± 20	25 ± 2	280 ± 20
# 8 - 32 UNC	13 ± 2	25 ± 5	282 ± 30	29 ± 3	330 ± 30	41 ± 4	460 ± 45
# 8 - 36 UNF				31 ± 3	350 ± 30	43 ± 4	31 ± 3
# 10 - 24 UNC	18 ± 2	30 ± 5	339 ± 56	42 ± 4	475 ± 45	60 ± 6	674 ± 70
#10 - 32 UNF				48 ± 4	540 ± 45	68 ± 6	765 ± 70
1/4 - 20 UNC	48 ± 7	53 ± 7	599 ± 79	100 ± 10	1125 ± 100	140 ± 15	1580 ± 170
1/4 - 28 UNF	53 ± 7	65 ± 10	734 ± 113	115 ± 10	1300 ± 100	160 ± 15	1800 ± 170
5/16 - 18 UNC	115 ± 15	105 ± 17	1186 ± 169	200 ± 25	2250 ± 280	300 ± 30	3390 ± 340
5/16 - 24 UNF	138 ± 17	128 ± 17	1446 ± 192	225 ± 25	2540 ± 280	325 ± 30	3670 ± 340
	ft-lb	ft-lb	N-m	ft-lb	N-m	ft-lb	N-m
3/8 - 16 UNC	16 ± 2	16 ± 2	22 ± 3	30 ± 3	41 ± 4	43 ± 4	58 ± 5
3/8 - 24 UNF	17 ± 2	18 ± 2	24 ± 3	35 ± 3	47 ± 4	50 ± 4	68 ± 5
7/16 - 14 UNC	27 ± 3	27 ± 3	37 ± 4	50 ± 5	68 ± 7	70 ± 7	68 ± 9
7/16 - 20 UNF	29 ± 3	29 ± 3	39 ± 4	55 ± 5	75 ± 7	77 ± 7	104 ± 9
1/2 - 13 UNC	30 ± 3	48 ± 7	65 ± 9	75 ± 8	102 ± 11	105 ± 10	142 ± 14
1/2 - 20 UNF	32 ± 3	53 ± 7	72 ± 9	85 ± 8	115 ± 11	120 ± 10	163 ± 14
5/8 - 11 UNC	65 ± 10	88 ± 12	119 ± 16	150 ± 15	203 ± 20	210 ± 20	285 ± 27
5/8 - 18 UNF	75 ± 10	95 ± 15	129 ± 20	170 ± 15	230 ± 20	240 ± 20	325 ± 27
3/4 - 10 UNC	93 ± 12	140 ± 20	190 ± 27	265 ± 25	359 ± 34	374 ± 35	508 ± 47
3/4 - 16 UNF	115 ± 15	165 ± 25	224 ± 34	300 ± 25	407 ± 34	420 ± 35	569 ± 47
7/8 - 9 UNC	140 ± 20	225 ± 25	305 ± 34	430 ± 45	583 ± 61	600 ± 60	813 ± 81
7/8 - 14 UNF	155 ± 25	260 ± 30	353 ± 41	475 ± 45	644 ± 61	660 ± 60	895 ± 81

Note: Reduce torque values listed in the table above by 25% for lubricated fasteners. Lubricated fasteners are defined as threads coated with a lubricant such as oil, graphite, or thread sealant such as Loctite.

Note: Torque values may have to be reduced when installing fasteners into threaded aluminum or brass. The specific torque value should be determined based on the fastener size, the aluminum or base material strength, length of thread engagement, etc.

Note: The nominal torque values listed above for Grade 5 and 8 fasteners are based on 75% of the minimum proof load specified in SAE J429. The tolerance is approximately ± 10% of the nominal torque value. Thin height nuts include jam nuts.

SPECIFICATIONS

Standard Torque for Dry, Zinc, and Steel Fasteners (Metric Fasteners)

Thread Size	Class 8.8 Bolts, Screws, and Studs with Regular Height Nuts (Class 8 or Strong Nuts)		Class 10.9 Bolts, Screws, and Studs with Regular Height Nuts (Class 10 or Strong Nuts)	
M5 X 0.8	57 ± 5 in-lb	640 ± 60 N-cm	78 ± 7 in-lb	885 ± 80 N-cm
M6 X 1.0	96 ± 9 in-lb	1018 ± 100 N-cm	133 ± 13 in-lb	1500 ± 150 N-cm
M8 X 1.25	19 ± 2 ft-lb	26 ± 3 N-m	27 ± 2 ft-lb	36 ± 3 N-m
M10 X 1.5	38 ± 4 ft-lb	52 ± 5 N-m	53 ± 5 ft-lb	72 ± 7 N-m
M12 X 1.75	66 ± 7 ft-lb	90 ± 10 N-m	92 ± 9 ft-lb	125 ± 12 N-m
M16 X 2.0	166 ± 15 ft-lb	225 ± 20 N-m	229 ± 22 ft-lb	310 ± 30 N-m
M20 X 2.5	325 ± 33 ft-lb	440 ± 45 N-m	450 ± 37 ft-lb	610 ± 50 N-m

Note: Reduce torque values listed in the table above by 25% for lubricated fasteners. Lubricated fasteners are defined as threads coated with a lubricant such as oil, graphite, or thread sealant such as Loctite.

Note: The nominal torque values listed above are based on 75% of the minimum proof load specified in SAE J1199. The tolerance is approximately ± 10% of the nominal torque value. Thin height nuts include jam nuts.

Note: Torque values may have to be reduced when installing fasteners into threaded aluminum or brass. The specific torque value should be determined based on the fastener size, the aluminum or base material strength, length of thread engagement, etc.

SPECIFICATIONS

Other Torque Specifications

SAE Grade 8 Steel Set Screws

Thread Size	Recommended Torque	
	Square Head	Hex Socket
1/4 - 20 UNC	140 ± 20 in-lb	73 ± 12 in-lb
5/16 - 18 UNC	215 ± 35 in-lb	145 ± 20 in-lb
3/8 - 16 UNC	35 ± 10 ft-lb	18 ± 3 ft-lb
1/2 - 13 UNC	75 ± 15 ft-lb	50 ± 10 ft-lb

Wheel Bolts and Lug Nuts

Thread Size	Recommended Torque**	
7/16 - 20 UNF Grade 5	65 ± 10 ft-lb	88 ± 14 N-m
1/2 - 20 UNF Grade 5	80 ± 10 ft-lb	108 ± 14 N-m
M12 X 1.25 Class 8.8	80 ± 10 ft-lb	108 ± 14 N-m
M12 X 1.5 Class 8.8	80 ± 10 ft-lb	108 ± 14 N-m

** For steel wheels and non-lubricated fasteners.

Thread Cutting Screws (Zinc Plated Steel)

Type 1, Type 23, or Type F	
Thread Size	Baseline Torque*
No. 6 - 32 UNC	20 ± 5 in-lb
No. 8 - 32 UNC	30 ± 5 in-lb
No.10 - 24 UNC	38 ± 7 in-lb
1/4 - 20 UNC	85 ± 15 in-lb
5/16 - 18 UNC	110 ± 20 in-lb
3/8 - 16 UNC	200 ± 100 in-lb

Thread Cutting Screws (Zinc Plated Steel)

Thread Size	Threads per Inch		Baseline Torque*
	Type A	Type B	
No. 6	18	20	20 ± 5 in-lb
No. 8	15	18	30 ± 5 in-lb
No. 10	12	16	38 ± 7 in-lb
No. 12	11	14	85 ± 15 in-lb

* Hole size, material strength, material thickness and finish must be considered when determining specific torque values. All torque values are based on non-lubricated fasteners.

Conversion Factors

$$\begin{aligned} \text{in-lb} \times 11.2985 &= \text{N-cm} \\ \text{ft-lb} \times 1.3558 &= \text{N-m} \end{aligned}$$

$$\begin{aligned} \text{N-cm} \times 0.08851 &= \text{in-lb} \\ \text{N-cm} \times 0.73776 &= \text{ft-lb} \end{aligned}$$

SPECIFICATIONS

Equivalents and Conversions

Decimal and Millimeter Equivalents

Fractions	Decimals	mm	Fractions	Decimals	mm
1/64	0.015625	0.397	33/64	0.515625	13.097
1/32	0.03125	0.794	16/32	0.53125	13.484
3/64	0.046875	1.191	35/64	0.546875	13.891
1/16	0.0625	1.588	9/16	0.5625	14.288
5/64	0.078125	1.984	37/64	0.578125	14.684
3/32	0.9375	2.381	19/32	0.59375	15.081
1/8	0.1250	3.175	5/8	0.6250	15.875
9/64	0.140625	3.572	41/64	0.640625	16.272
5/32	0.15625	3.969	21/32	0.65625	16.669
11/64	0.171875	4.366	43/64	0.671875	17.066
3/16	0.1875	4.762	11/16	0.6875	17.462
13/64	0.203125	5.159	45/64	0.703125	17.859
7/32	0.21875	5.556	23/32	0.71875	18.256
15/64	0.234375	5.953	47/64	0.734375	18.653
1/4	0.2500	6.350	3/4	0.7500	19.050
17/64	0.265625	6.747	49/64	0.765625	19.447
9/32	0.28125	7.144	25/32	0.78125	19.844
19/64	0.296875	7.541	51/64	0.796875	20.241
5/16	0.3125	7.541	13/16	0.8125	20.638
21/64	0.328125	8.334	53/64	0.828125	21.034
11/32	0.34375	8.731	27/32	0.84375	21.431
23/64	0.359375	9.128	55/64	0.859375	21.828
3/8	0.3750	9.525	7/8	0.8750	22.225
25/64	0.390625	9.922	57/64	0.890625	22.622
13/32	0.40625	10.319	29/32	0.90625	23.019
27/64	0.421875	10.716	59/64	0.921875	23.416
7/16	0.4375	11.112	15/16	0.9375	23.812
29/64	0.453125	11.509	61/64	0.953125	24.209
15/32	0.46875	11.906	31/32	0.96875	24.606
31/64	0.484375	12.303	63/64	0.984375	25.003
1/2	0.5000	12.700	1	1.000	25.400
1 mm = 0.03937 in.			0.001 in. = 0.0254 mm		

SPECIFICATIONS

U.S. to Metric Conversions

	To Convert	Into	Multiply By
Linear Measurement	Miles	Kilometers	1.609
	Yards	Meters	0.9144
	Feet	Meters	0.3048
	Feet	Centimeters	30.48
	Inches	Meters	0.0254
	Inches	Centimeters	2.54
	Inches	Millimeters	25.4
Area	Square Miles	Square Kilometers	2.59
	Square Feet	Square Meters	0.0929
	Square Inches	Square Centimeters	6.452
	Acre	Hectare	0.4047
Volume	Cubic Yards	Cubic Meters	0.7646
	Cubic Feet	Cubic Meters	0.02832
	Cubic Inches	Cubic Centimeters	16.39
Weight	Tons (Short)	Metric Tons	0.9078
	Pounds	Kilograms	0.4536
	Ounces	Grams	28.3495
Pressure	Pounds/Sq. In.	Kilopascal	6.895
Work	Foot-pounds	Newton-Meters	1.356
	Foot-pounds	Kilogram-Meters	0.1383
	Inch-pounds	Kilogram-Centimeters	1.152144
Liquid Volume	Quarts	Liters	0.9463
	Gallons	Liters	3.785
Liquid Flows	Gallons/Minute	Liters/Minute	3.785
Temperature	Fahrenheit	Celsius	1. Subtract 32° 2. Multiply by 5/9

Service Information

The Power Max snowthrowers have both 2-cycle and 4-cycle engines. The process for obtaining parts and service information is different between them.

4-Cycle Engine

All 4 cycle models use a Tecumseh Snow King engine. Service information can be obtained through Tecumseh at the following address.

Tecumseh Products Company
Engine and Transmission Group
Service Division
900 North Street
Grafton, WI 53024
Phone 262-377-2700

2-Cycle Engine

All 2-cycle models use the Toro R tek engine. Service is handled through the Toro system. Detailed engine repair information is available in the "E" Engine Service Manual, Form No. 492-0647.

Servicing the R tek Engine

Use the following process to service the R tek engine.

1. Remove the three screws across the front of the engine shroud and 2 screws on each side where the front and rear shroud meet (Fig. 003).

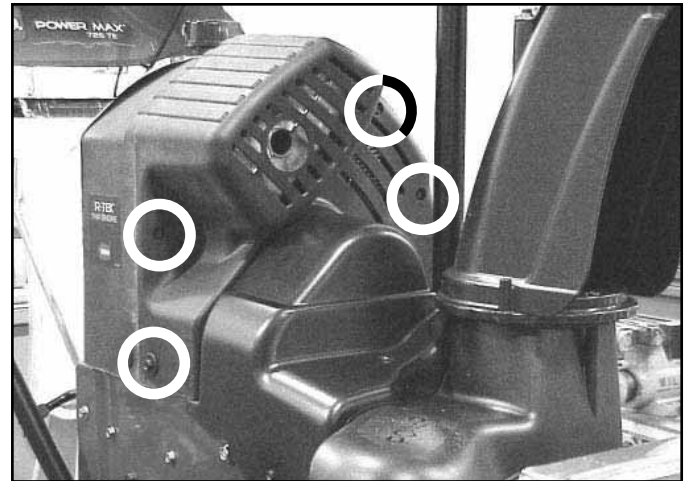

Fig 003

MVC-001X

2. Remove 4 screws securing the belt covers; remove the belt covers. (Reassembly will be much easier if the belt covers have been removed.)

ENGINE

3. Pull the front shroud forward and up to remove. Slide the rear cover to the rear and rotate it clockwise to slip over the electric starter button and extension cord plug located in the left rear corner (Fig. 004).

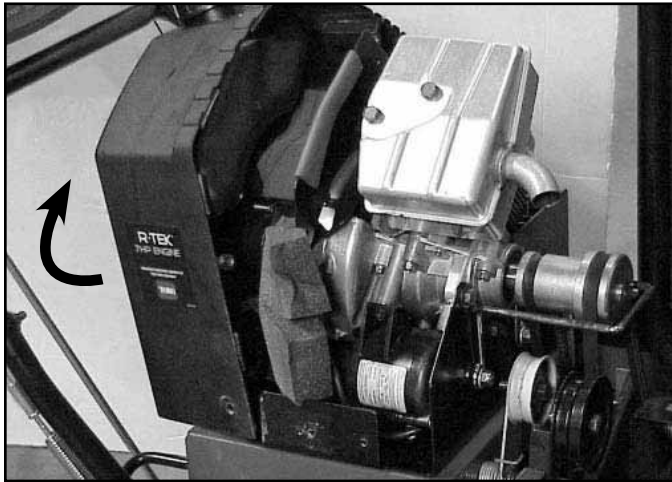

Fig 004

MVC-900XB

To remove the primer button, pull the primer line off the stem and compress the tabs. The primer will push out to the rear (Fig. 005).

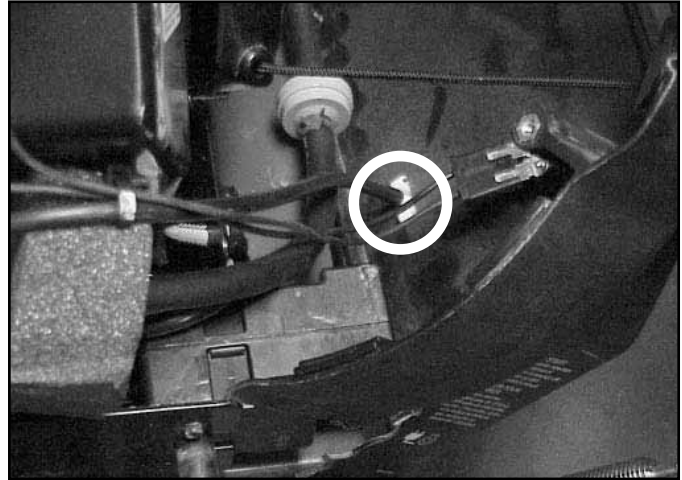

Fig 005

MVC-865XA

Primer Button

When depressed the primer button pressurizes the carburetor bowl. Fuel is forced up the main tube to the carburetor venturi. This line and button are the atmospheric vent for the carburetor bowl. If the line is kinked or the vent hole in the bulb is plugged, the carburetor may flood.

Ignition Switch

To remove the ignition switch, pull the wire harness off the switch terminals. The switch is a snap in type. To remove the switch, depress the ears on the switch body (Fig. 006) and push the switch out through the rear of the shroud. Switch troubleshooting is provided in the electrical section.

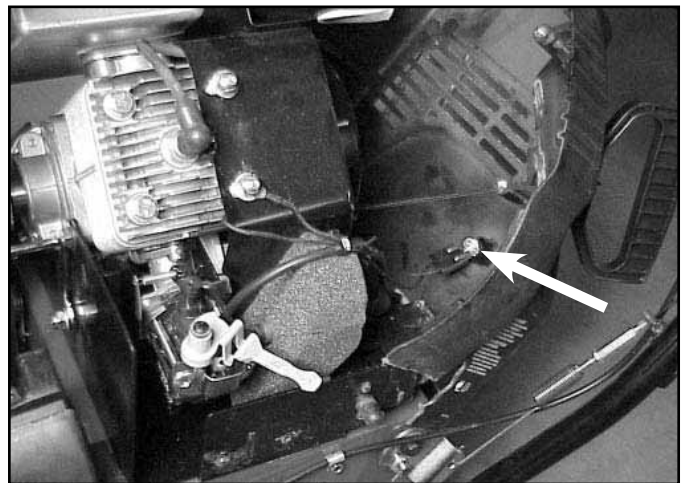

Fig 006

MVC-863XA

Fuel Tank, Fuel Line and Fuel Filter

To remove the fuel tank, unscrew the gas cap, slip the tank out of the shroud and install the cap. If there is fuel in the tank, clamp the line, or drain the tank into a suitable container. Remove the fuel line and fuel filter. The tank is held in place by the bracket and shroud surrounding it (Fig. 007).

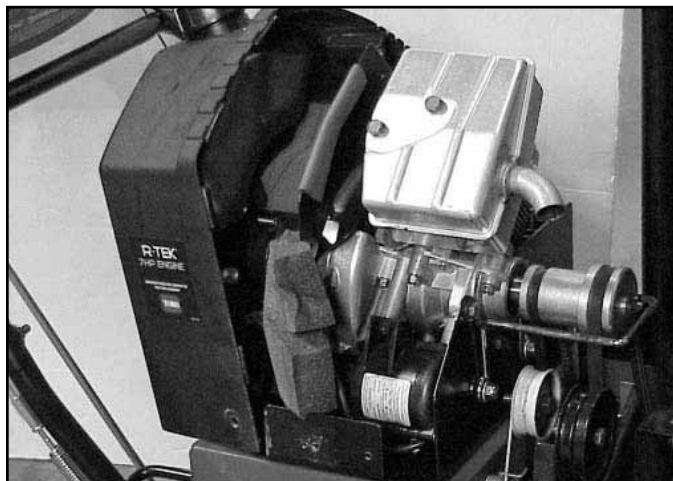

Fig 007

MVC-000

Primer Line Routing

The primer line connects to the back side of the primer then is routed over the fuel line, over the foam block (Fig. 008).

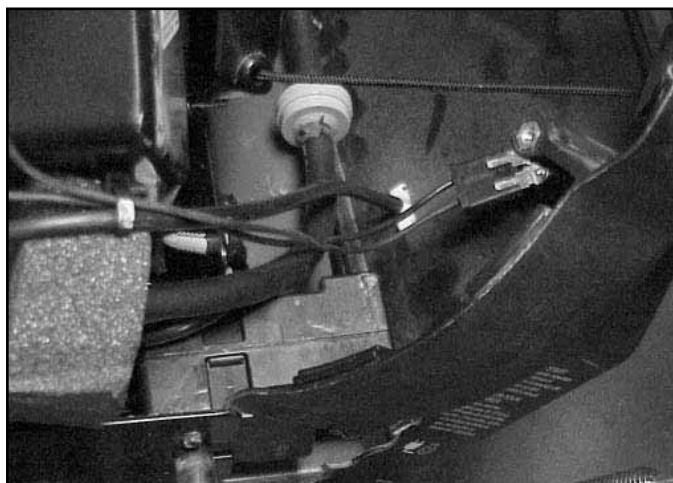

Fig 008

MVC-865XA

It should be gathered and secured to the ignition switch wires. It then goes down to the primer fitting on top of the carburetor (Fig. 009).

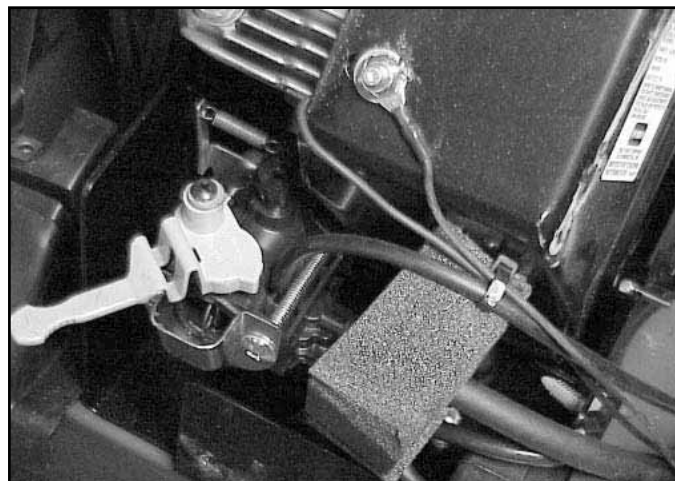

Fig 009

MVC-866XA

Engine Shroud Assembly

1. Ensure the ignition switch is in place and the wire harness is plugged in, the primer line is attached to the primer and the primer body is secure in its slot, and the fuel tank, fuel line and filter are properly installed.

ENGINE

2. Begin in the left rear corner; slip the shroud over the electric start button and the plug terminal for the extension cord (Fig. 010). Then rotate the shroud clockwise into place.

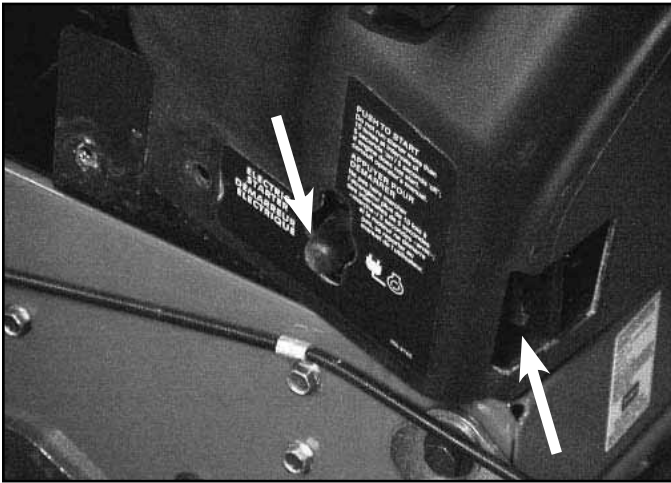

Fig 010

MVC-893XC

3. While the engine shroud is still loose, install both belt covers. Then install and secure the front and rear engine covers to each other and to the chassis.

QUICK STICK

Operation

The Quick Stick is a single lever control for chute side-to-side movement and vertical movement of the deflector (Fig. 011).



Fig 011

MVC-775X

When the operator places their hand on the stick the cover is depressed, which draws a cable to unlatch the chute (Fig. 012). Side to side motion rotates the rod and gear and causes the chute to pivot side to side.



Fig 012

MVC-039F

The deflector up and down motion is unlatched inside the quick stick itself and a cable controls the up and down motion.

Removing the cover just behind the chute allows access to the chute rotation gears and chute latch (Fig. 013). Since these gears are plastic they do not require lubrication. The latch cable adjustment is covered in the control adjustment section.

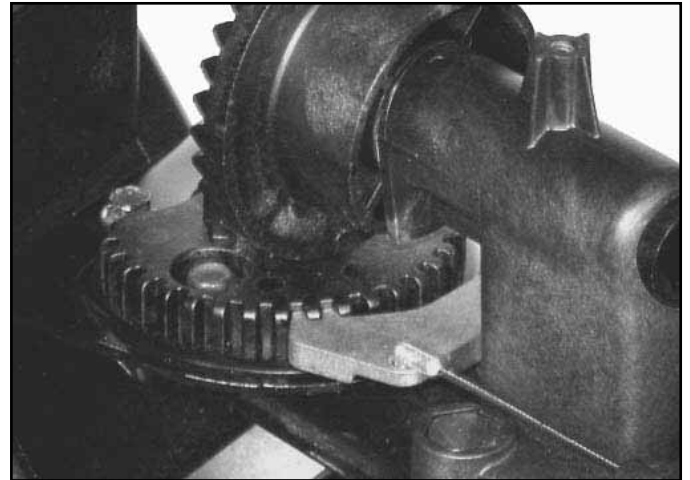

Fig 013

MVC-772X

Removal

1. To remove the Quick Stick, unhook the Z bend and disconnect the deflector cable from the underside of the Quick Stick (Fig. 014).



Fig 014

MVC-870XA

CONTROLS

2. On the underside of the control panel, remove the two screws holding the Quick Stick cover in place (Fig. 015).

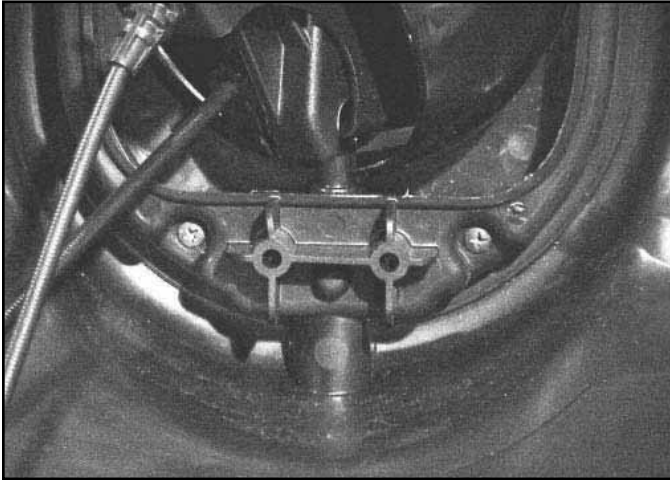

Fig 015

MVC-1869X

4. Remove the two screws that retain the rod support to the control panel (Fig. 017).

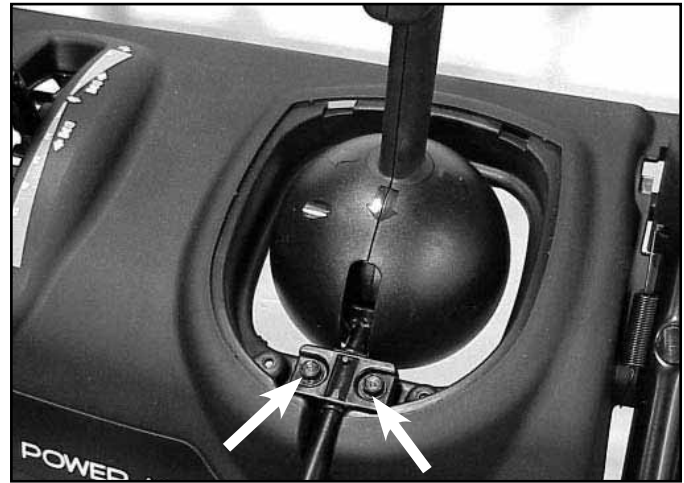

Fig 017

MVC-819X

3. Lift the front cover and pull forward to release the latch tabs on the rear. Set the cover aside (Fig. 016).



Fig 016

MVC-902X

5. Remove the two carriage bolts and nuts on the chute control rod and lift the Quick Stick out of the control panel. Note the location of the cable clamp, as it is necessary for latch cable function (Fig. 018).

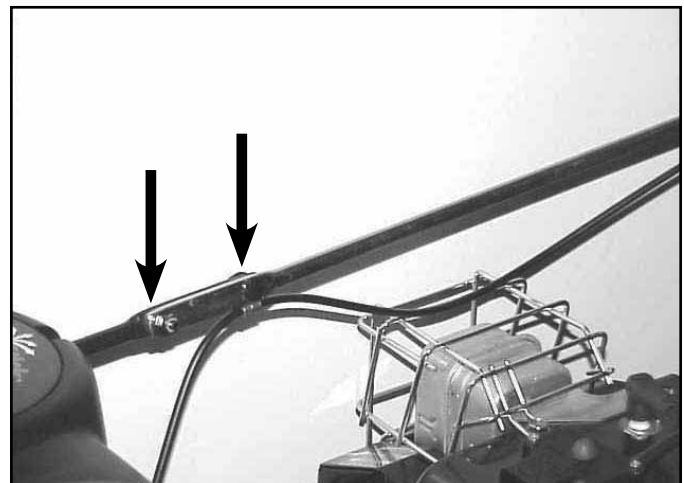

Fig 018

MVC-725F

CONTROLS

Disassembly

1. To begin disassembly of the Quick Stick, remove the screw retaining the blue lever cap and remove the cap (Fig. 019).

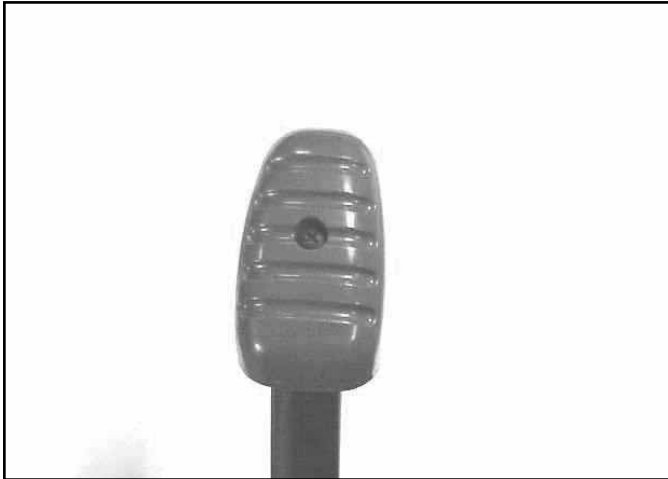

Fig 019

MVC-546F

2. Remove the two screws on the right hand side of the chute control cover (the part that looks like a ball). Remove both halves and set aside (Fig. 020).

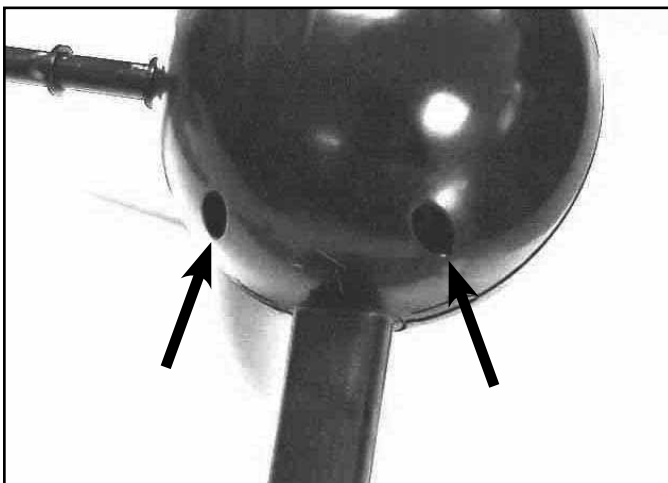

Fig 020

MVC-547F

3. Remove the locknut and flat washer from the shoulder bolt. Slide the chute control rod off and remove the rubber washer and friction plate (Fig. 021).



Fig 021

MVC-832S

4. Hold the Quick Stick so the three screws holding the handle halves are facing up. Remove the three screws and lift off the top handle half (Fig. 022).

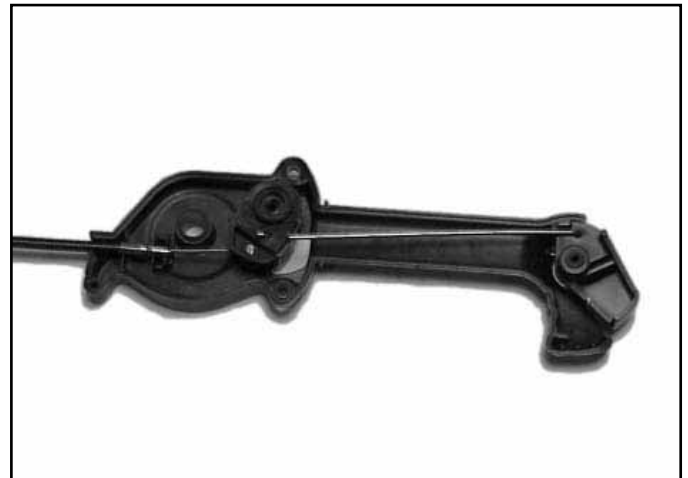

Fig 022

MVC-8335X

CONTROLS

5. Lift the metal latch pawl off the hex on the cable lever. Lift out the latch trigger and spring. Note the orientation of the pawl to the lever for reassembly (Fig. 023).

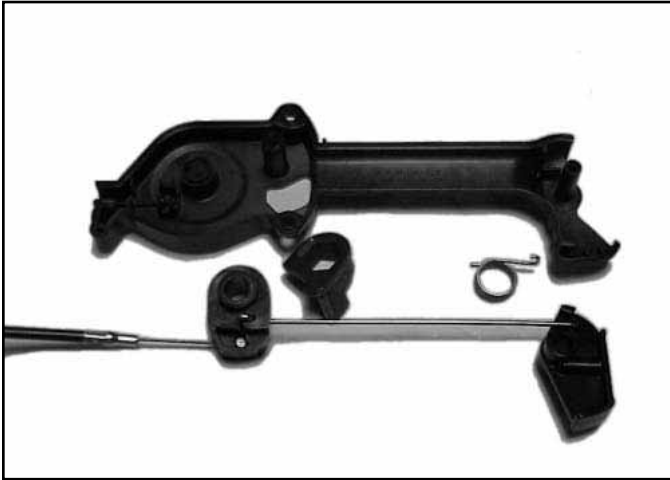

Fig 023

MVC-837X

Reassembly

1. Begin assembly by dropping the latch spring over the boss. The straight end of the spring should be down with the hooked end up (Fig. 025).



Fig 025

MVC-759F

6. Rotate the cable until the barrel fitting slides off the cable lever (Fig. 024).

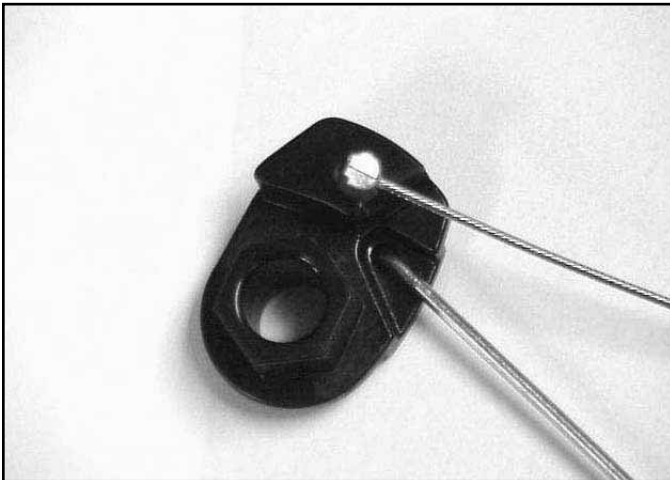

Fig 024

MVC-554F

2. Slide the latch trigger over the boss until it is fully seated, making sure that the stop on the trigger lever is above the stop on the quick lever, as shown. While holding the trigger lever in place, rotate the hooked end of the spring until it hooks under the front edge of the trigger lever as shown (Fig. 026).

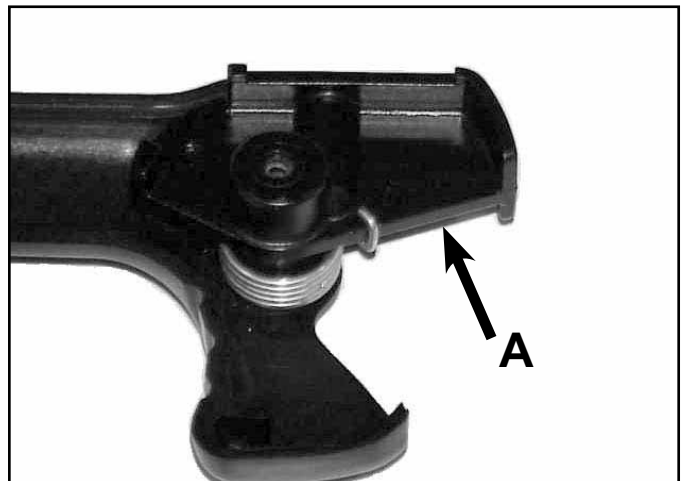

Fig 026

MVC-758F

A. Latch trigger

- Reverse the disassembly process for the remainder of the assembly.

Installation

Reverse the removal process for installation.

Note: The cable clamp must be installed on the chute control rod or the cable latch will not function.

CONTROL INTERLOCK

For operator convenience there is an interlock between the auger and traction lever. Once both are engaged you only need to hold the auger lever. This allows a free hand to change chute direction without having to stop. The latch mechanism is located under the dash (Fig. 027).

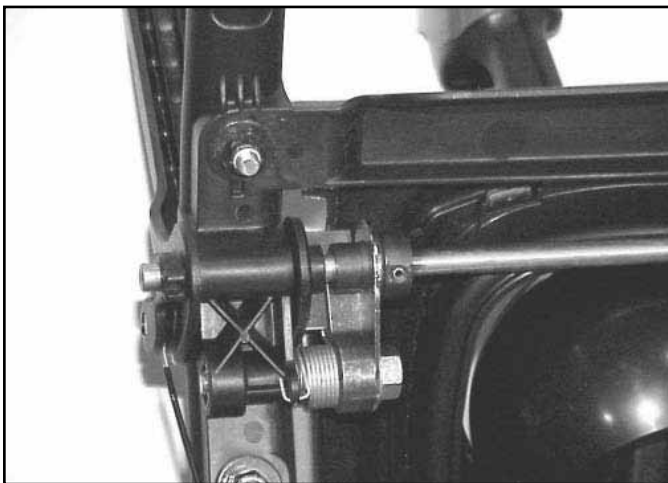

Fig 027

MVC-872X

Disassembly

- Disconnect the auger and traction cables from the levers. If this is a wheel clutch model, disconnect the wheel clutch cables (Fig. 028).



Fig 028

MVC-171X

- Remove the Shoulder Screw under the left handgrip (Fig. 029). When it is removed the Lockout Latch, Torsion Spring, Flat Washer, and Locknut will drop out.

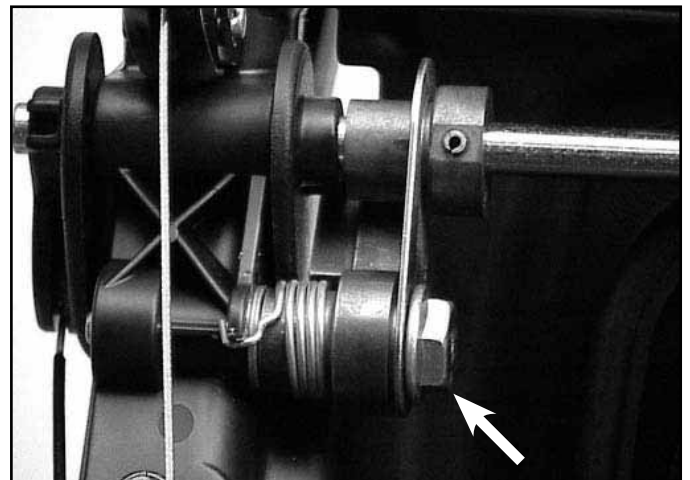

Fig 029

MVC-167X

CONTROLS

3. To remove the lockout rod, go to the right hand end. There are 2 roll pins on the right side (Fig. 030) and one in the lockout cam on the left (Fig. 031).

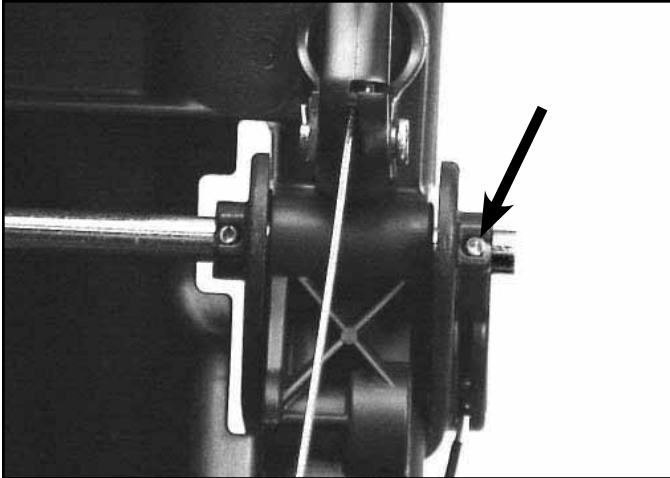

Fig 030

MVC-169X

4. Once they are driven out the lockout rod can be moved to the side and removed (Fig. 032). The lockout link can now be removed from the lockout rod.

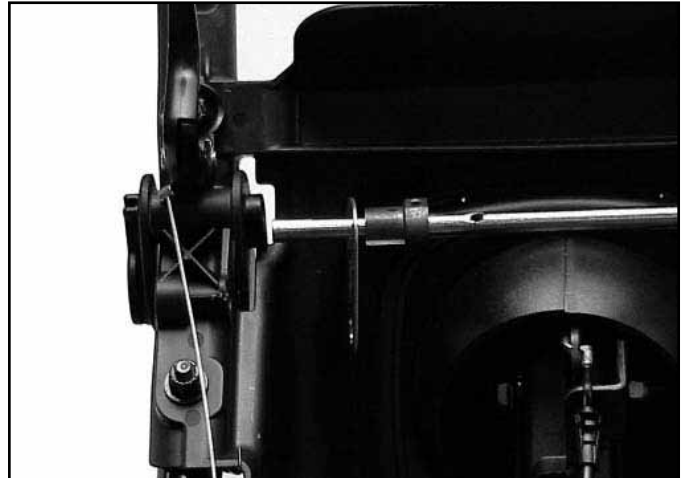

Fig 032

MVC-172X

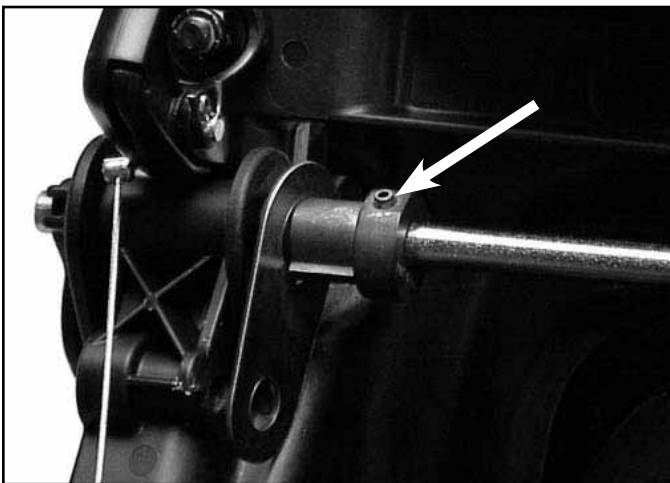

Fig 031

MVC-170X

5. Since the auger and traction levers pivot on the lockout rod this is the method required to replace the levers (Fig. 033).

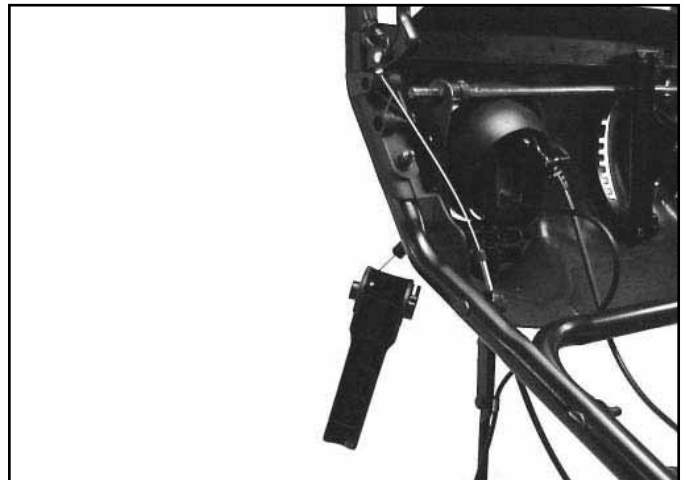

Fig 033

MVC-174X

Note: Steps 1 and 2 above do not need to be done in that order. In fact you can remove the rod without removing the shoulder bolt and vice versa.

Assembly

Reverse the above process for assembly.

Note the spring on the lockout latch. The end with the slight bend goes behind the lockout latch and the hooked end goes over the small tab. It is easiest to install the latch mechanism then hook the end of the spring with a wire and pull it into place (Fig. 034).

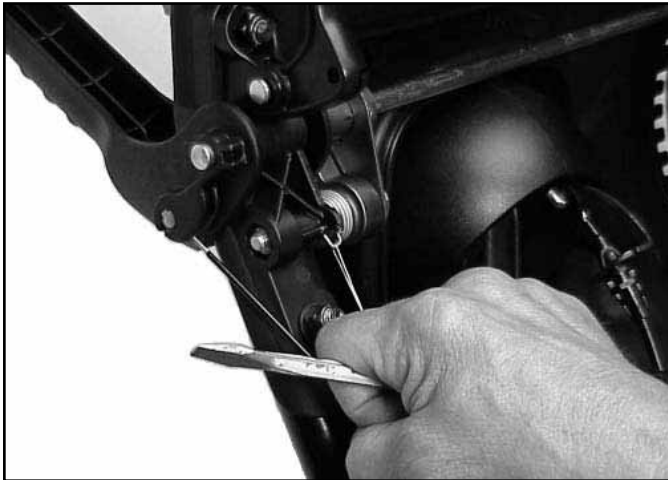

Fig 034

MVC-176X

CONTROL OPERATION, REPLACEMENT, AND ADJUSTMENT

Deflector Cable

1. To remove the deflector cable, depress the tabs that retain the cable in the bracket, under the control panel. Disconnect the Z bend on the end (Fig. 035).

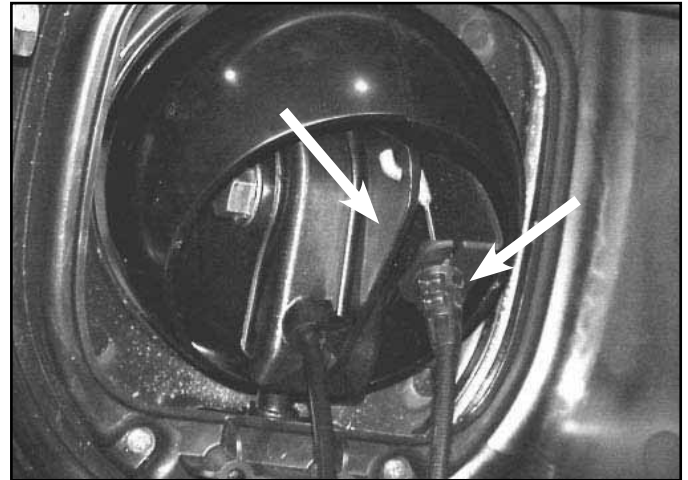

Fig 035

MVC-870X

2. Remove the cable clamp and disconnect the cable end from the deflector. Reverse this process to install a new cable (Fig. 036).

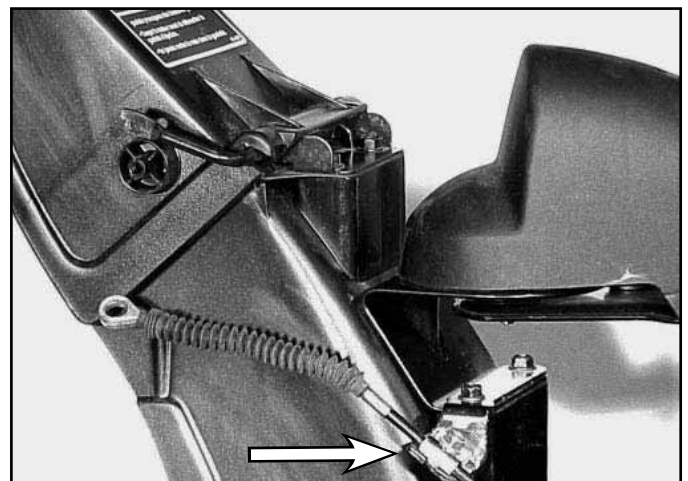

Fig 036

MVC-882X

CONTROLS

Deflector Cable Adjustment

Make sure the Quick Stick is in the maximum rear position and centered (Fig. 037); ensure the deflector is in the full upward position. Draw the slack out of the cable and secure the clamp (Fig. 036).



Fig 037

MVC-775X

SHIFT LEVER

The shift lever on the control panel is connected to the friction wheel in the traction drive by a shift rod. Moving the shift lever moves the friction wheel to change wheel direction and speed (Fig. 038).



Fig 038

MVC-901XA

Shift Rod Adjustment

1. The adjustment point is a trunion on the upper end of the shift rod (Fig. 039).

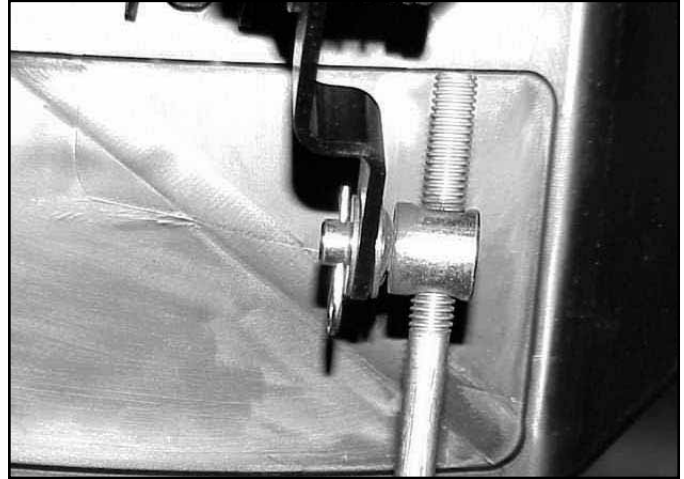

Fig 039

MVC-561F

2. Pull the shift rod and arm upward as far as they will go. With the shift lever in R2, adjust the trunion to take the slack out and resecure (Fig. 040).

Note: Excessive slack in the linkage may cause the drive to be in reverse when shifted into first gear.

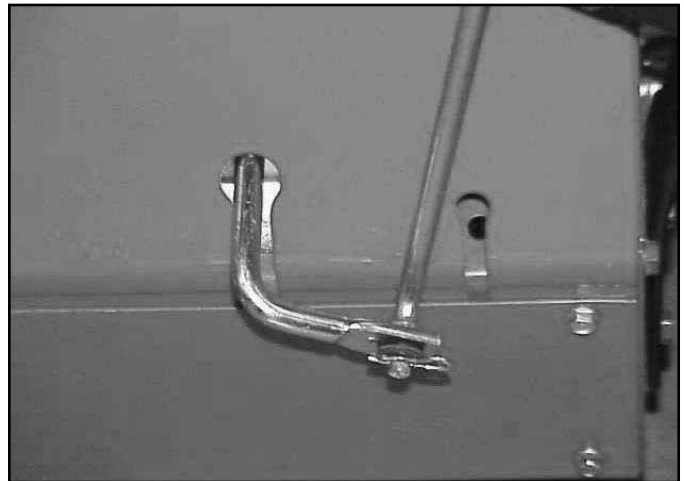

Fig 040

MVC-560F

Auger Control

The bail on the right hand handle is the auger control. Squeeze the bail and the cable causes an idler to pivot tensioning the auger belt (Fig. 041).



Fig 041

MVC-816X

Auger Cable Adjustment

1. The auger cable adjustment should be checked after the first 2 hours of use and annually thereafter. To begin, ensure the auger lever is in the full up position (Fig. 042).



Fig 042

MVC-901XA

2. Loosen the jam nut. The cable is adjusted using the turnbuckle on the lower end of the auger cable.

Note: When rotating the turnbuckle, hold the cable so it does not twist (Fig. 041).

3. Remove the right side belt cover. Adjust the turnbuckle until there is a 1/16" (1.5mm) gap between the stop and the auger clutch assembly. Secure the jam nut on the turnbuckle (Fig. 043).

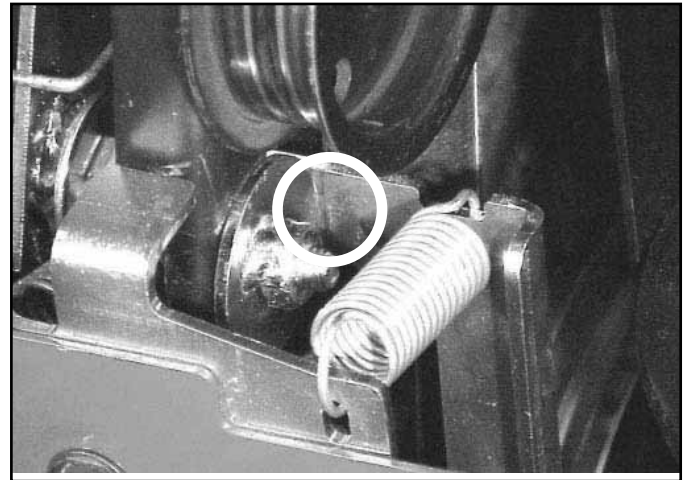

Fig 043

MVC-876X

Beginning with 2005 production there are two holes in the idler arm (Fig. 044). The idler pulley is initially installed in the outer hole. If necessary, the idler can be moved to achieve the correct tension. 2004 models have only one hole in the idler.

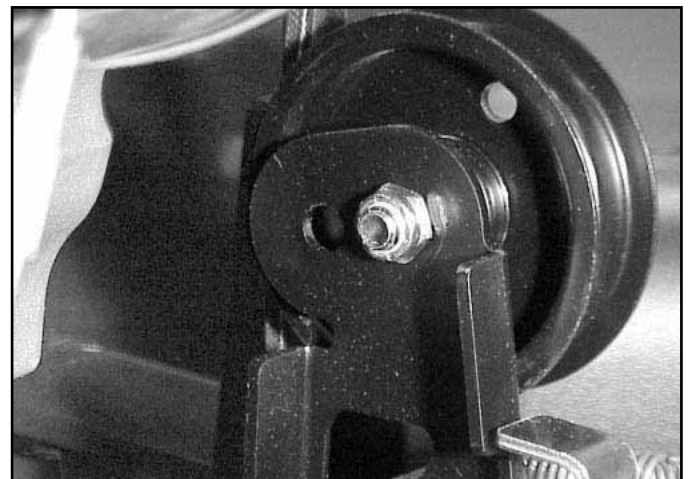

Fig 044

MVC-016X

CONTROLS

To determine if the pulley should be moved, proceed as follows: remove the right side belt cover. With the engine off, engage the auger lever. If there is more than 1" (2.5cm) gap between the idler arm and the stop, move the pulley to the inner hole (Fig. 045). If the gap is less than 1" (2.5cm) keep the pulley in the outer hole.

Note: If you move the idler pulley, it will be necessary to readjust both the auger brake and the auger cable.

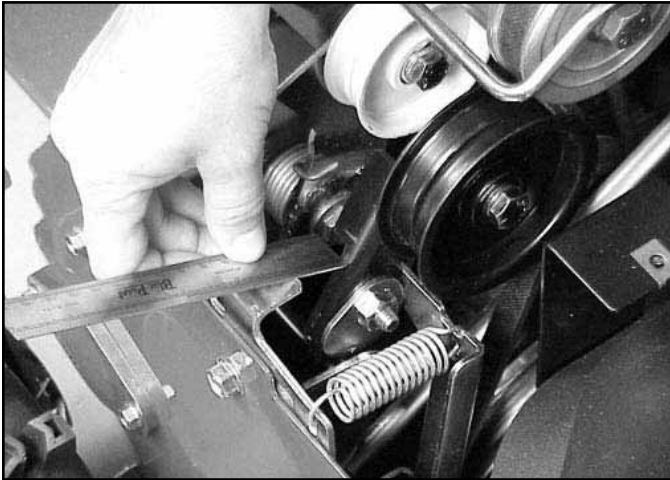

Fig 045

MVC-892XA

Auger Brake Adjustment

1. As the auger cable is adjusted to maintain proper belt tension, the idler will move towards the brake arm. The gap between the idler arm and brake arm may be reduced. Periodically, verify the gap as follows to make sure the brake engages properly.
2. Remove the belt cover and check the gap between the welded washer/nut assembly and the brake arm tab.

The gap should be .100" (2.5mm)

If adjustment is necessary, loosen the bolt through the welded washer/nut and rotate the washer/nut to achieve the gap. Secure the bolt (Fig. 046).

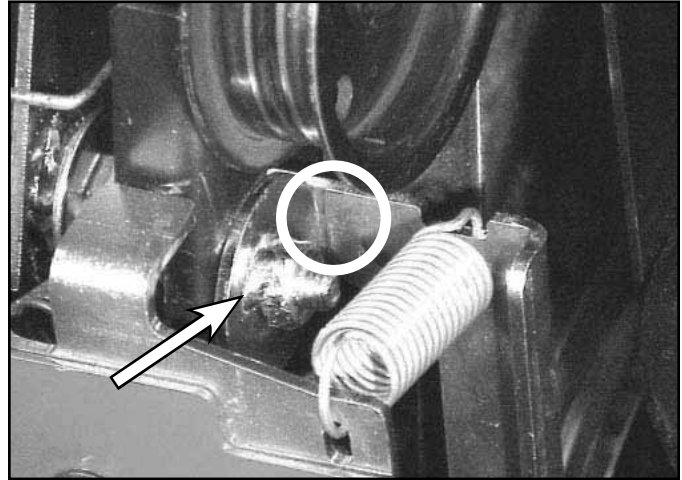

Fig 046

MVC-876X

Traction Control

The traction bail is on the left handle and when squeezed engages the wheel drive system (Fig. 047).



Fig 047

MVC-899XA

Traction Cable Adjustment

1. The traction lever should be in the full upright position with some slack in the traction cable to begin adjustment (Fig. 047).
2. Adjust using the turnbuckle; hold the cable to prevent twisting (Fig. 048).

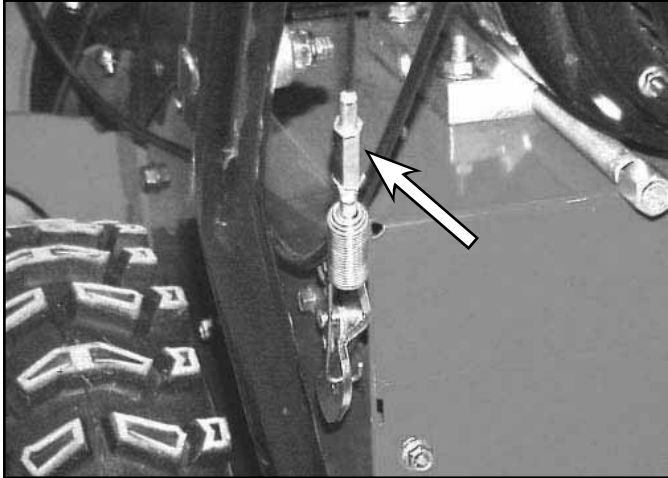

Fig 048

MVC-894X

3. Locate the traction rod on the left side just below the belt cover.

Adjust the cable turnbuckle until there is a slight gap between the end of the rod and the front of the slot (maximum 1/16" [1.5mm]). Secure the jam nut on the turnbuckle (Fig. 049). The left hand belt cover has been removed only for clarity.

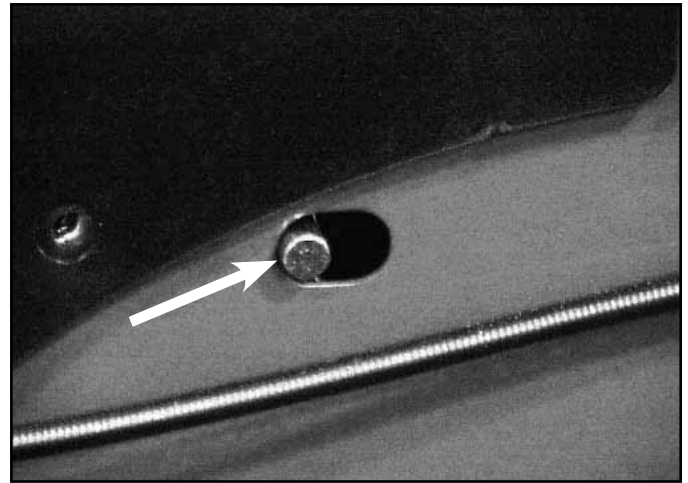

Fig 049

MVC-895X

REPLACE AND ADJUST WHEEL CLUTCH CABLES (wheel clutch models only)

Clutch Cable Replacement

1. To replace the clutch cables, drain the fuel tank and stand the machine on the auger. Remove both lower covers (Fig. 050). The wheels and the bottom cover can also be removed if desired.

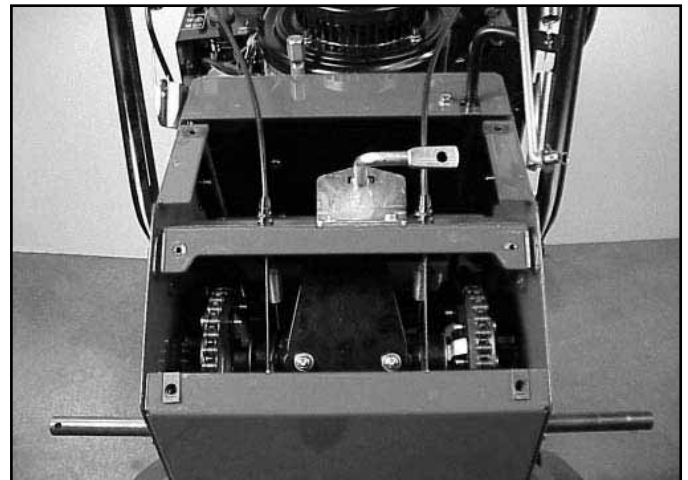

Fig 050

MVC-892X

CONTROLS

2. Remove nut and washer that attach the cable clamp to the handle (Fig. 051).

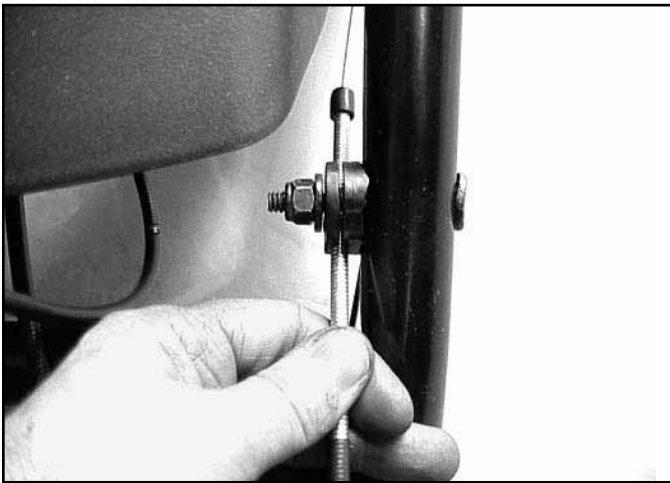

Fig 051

MVC-889XYL

5. Disconnect the lower end of the cable from the shift collar (Fig. 053).

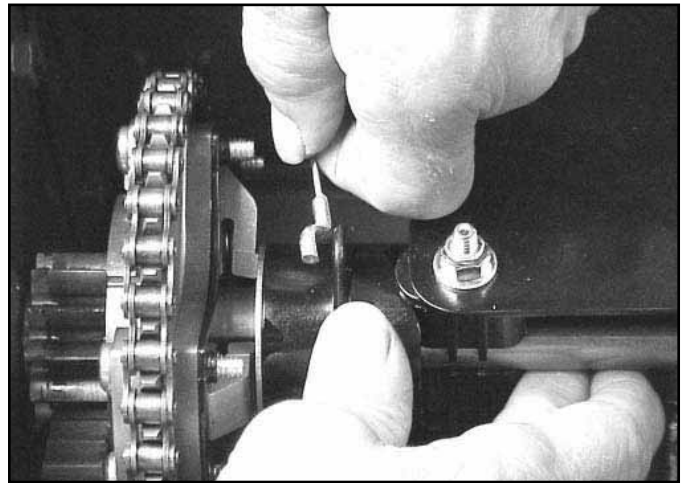

Fig 053

MVC-898XB

3. Slip the cable Z bend out of the wheel clutch lever on the handle.
4. Reach under the shift plate and compress the small ears on the cable fitting (Fig. 052). The cable fitting can then be pushed out of the shift plate.

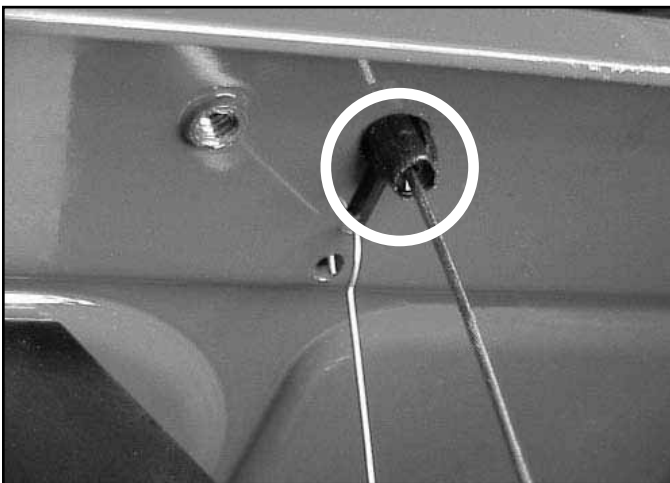

Fig 052

MVC-899X

Assembly

1. Feed the lower end of the cable through the shift plate and snap the cable into the plate. Install the lower end of the cable into the shift collar outside in, as shown (Fig. 054).

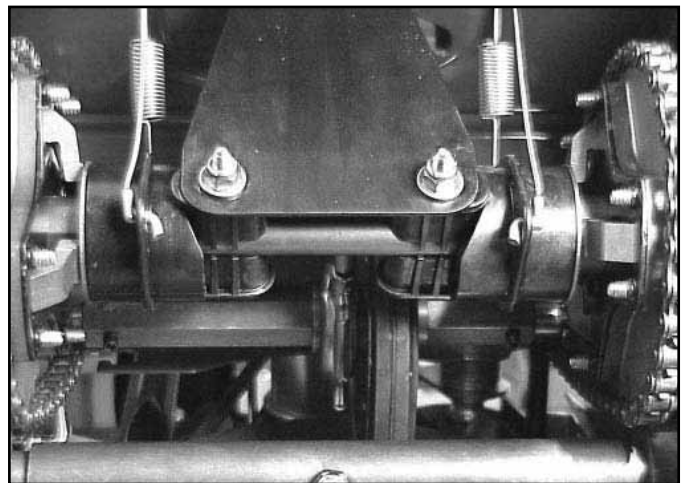

Fig 054

MVC-878XYZ1

- Hook the upper end of the cable to the wheel clutch lever and install the cable clamp to the handle. Go to Adjusting Clutch Cables for the adjustment procedure before securing the clamp.
- Install the covers and test run the unit.

Adjusting Clutch Cables

- Loosen the cable clamp nut (Fig. 055).

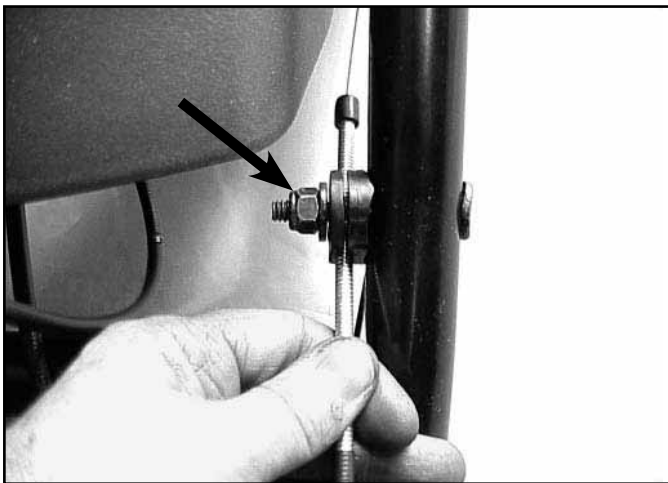

Fig 055

MVC-889XYL

- Pull the cable jacket down gently until the wheel clutch lever is down and the slack is out of the cable, and then tighten the cable clamp nut securely (Fig. 056).

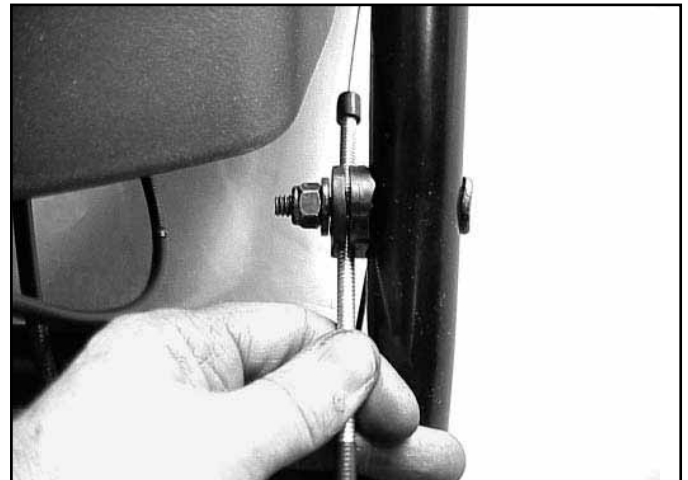

Fig 056

MVC-889XYL

- Squeeze the lever fully, and then check the gap between the bottom of the handle and the wheel clutch lever end.

Note: The gap should be approximately 1/4 inch (6mm). If it is greater, loosen the cable clamp nut, slide the cable jacket up slightly, tighten the cable clamp nut, and check the gap again. Repeat steps for other cable (Fig. 057).



Fig 057

MVC-891XLY

THIS PAGE INTENTIONALLY LEFT BLANK

BELT REPLACEMENT

AUGER BELT

1. To replace the belts begin by removing both belt covers (Fig. 058). (On 2-cycle models only, remove 3 screws holding the front half of the engine shroud to the chassis and the rear shroud. The belt cover slides under the front of the engine shroud so this will make belt cover removal much easier.)

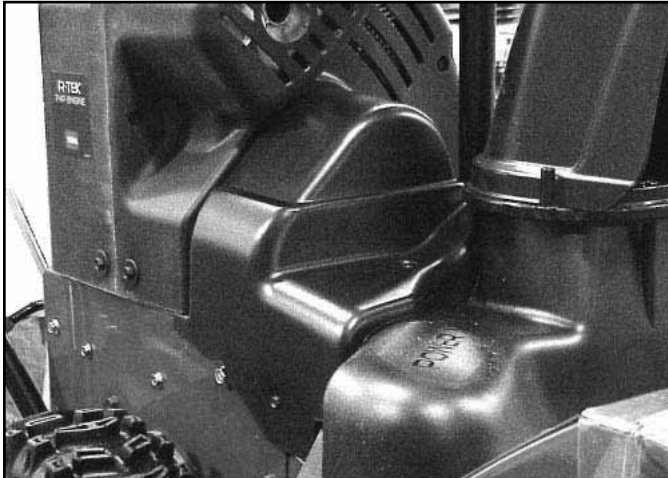

Fig 058

MVC-006XB

2. Remove the belt guide. Be careful to avoid bending the guide (Fig. 059).

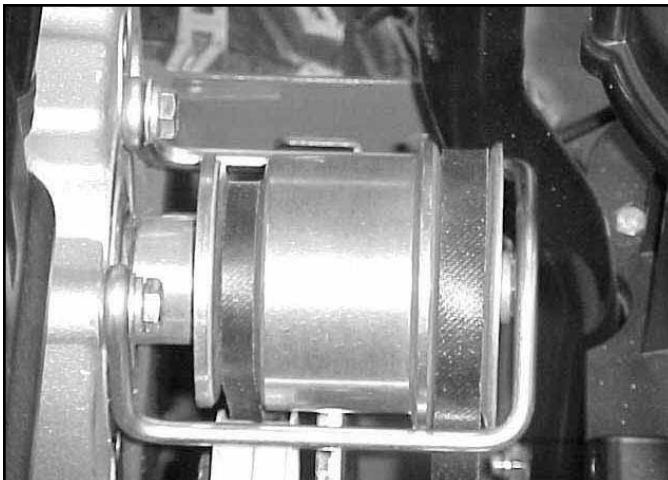

Fig 059

MVC-007F

3. Remove the brake assembly for more working room. Disconnect the spring, then remove the two bolts through the side plate (Fig. 060).

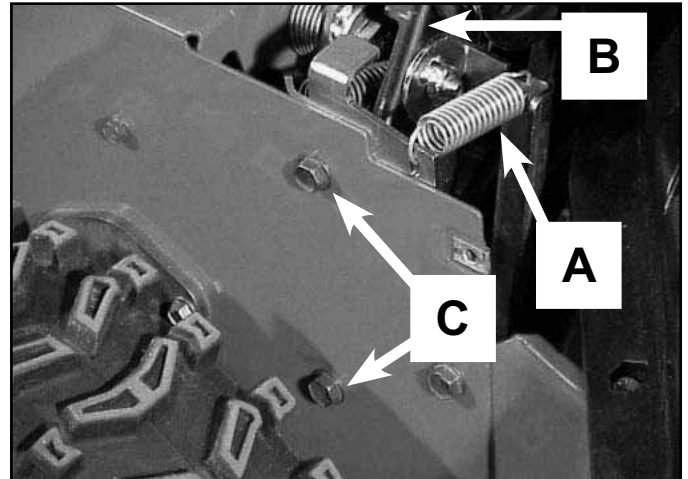

Fig 060

MVC-1883X

- A. Spring C. Bolts
B. Brake Assembly

4. The brake assembly can be lifted out of the chassis (Fig. 061).

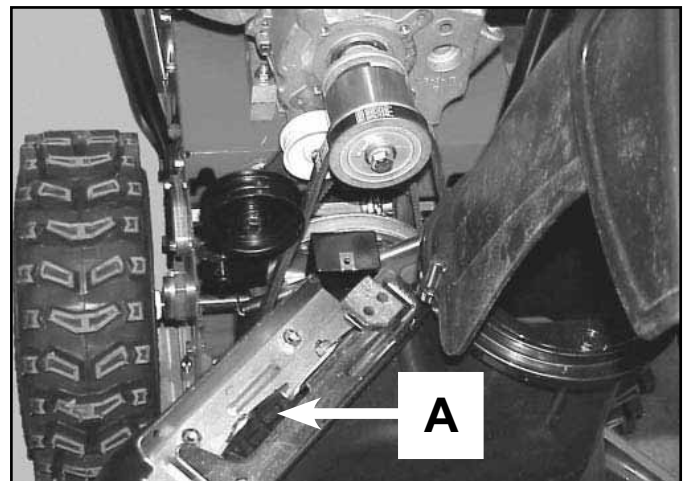

Fig 061

MVC-067X

- A. Brake Assembly

BELT REPLACEMENT

5. Remove the bolt securing the engine pulley to the crankshaft. If necessary, you can hold the hub between the pulley and engine to keep the crankshaft from turning. Remove the pulley flange and the auger belt from the crankshaft (Fig. 062).

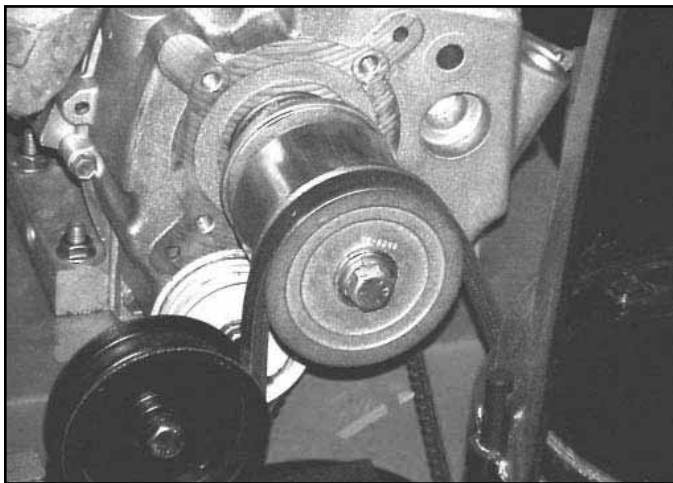

Fig 062

MVC-747X

6. The auger belt can now be removed from the impeller pulley (Fig. 063).

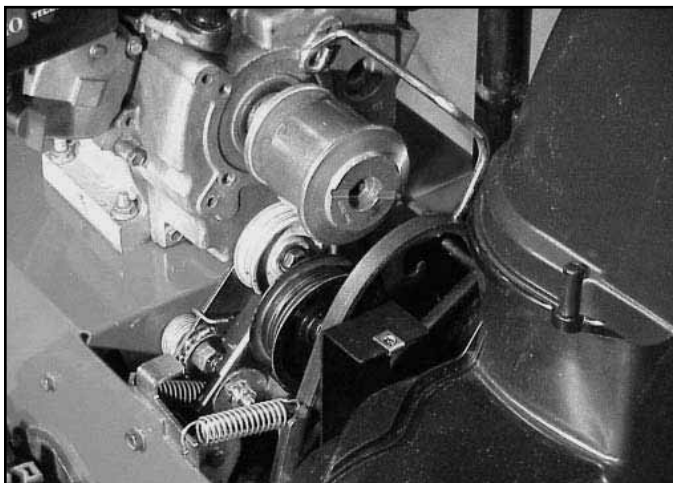

Fig 063

MVC-886XB

Reverse the process to install a new belt. Use Loctite 242 and torque the engine pulley to 29 ft-lbs. (39.3 Nm)

TRACTION BELT

To replace the traction belt, perform steps 1-5 above to remove the auger belt. Then proceed with the following steps.

1. Slip the center section of the crankshaft pulley off the crankshaft (Fig. 064).

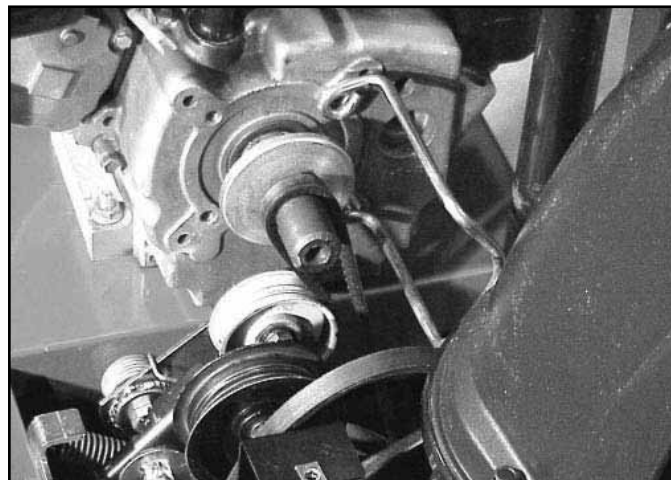

Fig 064

MVC-887X

2. On the left side of the machine, remove the hairpin cotter from the speed control link (Fig. 065).

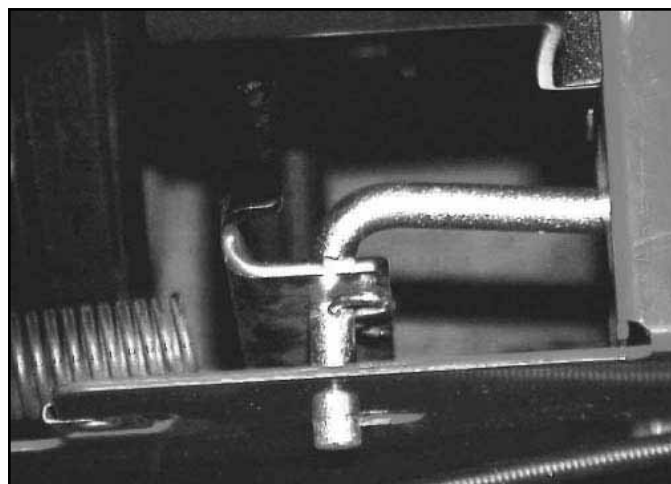

Fig 065

MVC-897X

BELT REPLACEMENT

3. Move the link to the side and let it rest in the saddle provided (Fig. 066). Reach down alongside the link and remove the belt from the lower pulley. Then remove the belt from the crankshaft pulley.

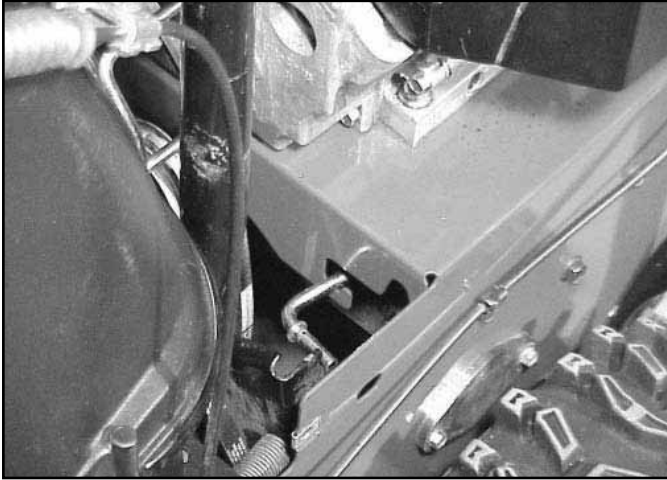

Fig 066

MVC-888XB

Belt Adjustment

Belt adjustments are made by adjusting the control cables. See the Controls Section for the procedure.

4. Reverse the process to install a new belt.
5. Check for proper clearance between the belt and belt guide. Engage the auger belt and look between the belt and belt guide on the left side. There should be about 1/8" (3.2mm) gap (Fig. 067). Tighten the belt guide mounting bolts.

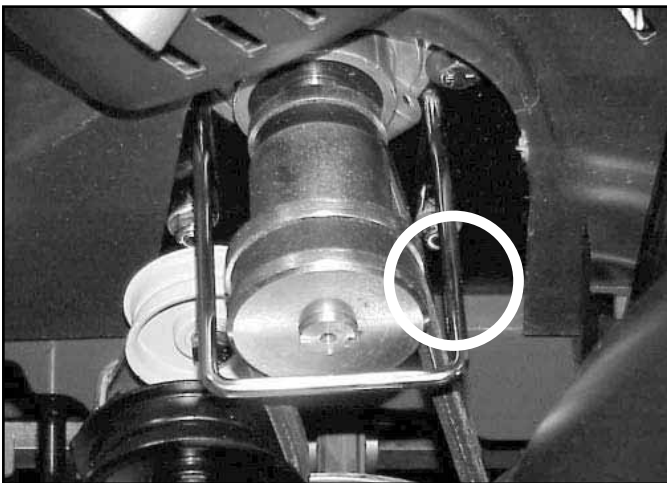

Fig 067

MVC-822X

THIS PAGE INTENTIONALLY LEFT BLANK

AUGER HOUSING

AUGER HOUSING COMPONENTS

The Power Max snow throwers are offered in two widths: 26" and 28" (66cm and 71cm). The augers, auger shaft, housing, and scrapers are made in both widths, but all other auger components are the same. The auger case halves, gears, impeller and impeller shaft, chute, etc. are interchangeable.

Removal of the auger and traction system components from the auger housing is covered in the Auger Gearbox Section and in the two traction drive systems sections (non-wheel clutch and wheel clutch).

SKIDS

The skids are located on each side of the auger. The skids are intended to be the component that touches the ground and supports the auger. They are also the means to adjust the auger height for different conditions (Fig. 068).



Fig 068

MVC-769X

See the scraper adjustment procedure to adjust the skids.

Note: The skids are reversible. When one side becomes worn out, remove the skid and turn it over for a new surface.

SCRAPER

The scraper is a replaceable surface attached to the leading edge of the auger housing. It is a wear part and will need to be replaced periodically in the life of the machine. There are two types of scrapers, fixed and pivoting.

Fixed Scraper

Because the fixed scraper is bolted solidly to the auger housing it is intended to be raised slightly off the ground to minimize catching on pavement cracks and solid objects. The amount that it should be raised depends on how rough the ground is. The scraper is adjustable as the mounting holes are slotted (Fig. 069).

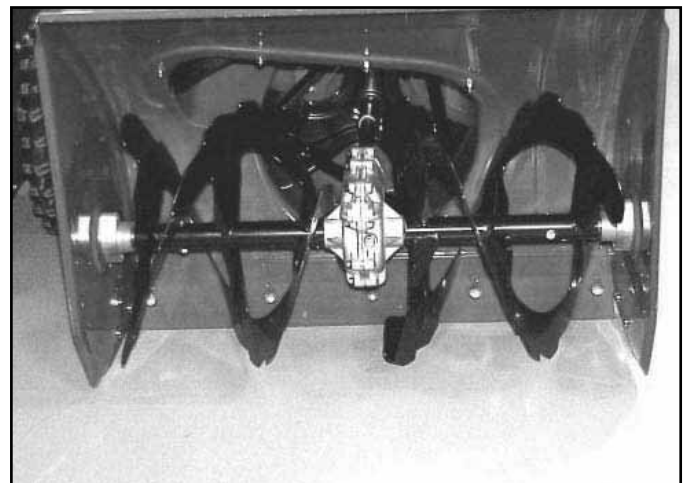

Fig 069

MVC-896X

Scraper Replacement

The scraper is attached with five carriage head bolts with locknuts. Install the new scraper but do not tighten the bolts until the scraper is adjusted.

AUGER HOUSING

Adjusting the Skids and Scraper - Fixed Scraper models

1. Check the tire pressure. It must be between 17 and 20 psi (116-137 kPa) and the same on both sides so the machine sets level.
2. Loosen the nuts that secure both skids so the skids can slide up and down easily.
3. Support the side plates so they are at least $\frac{1}{2}$ " (13mm) above a level surface (Fig. 070).

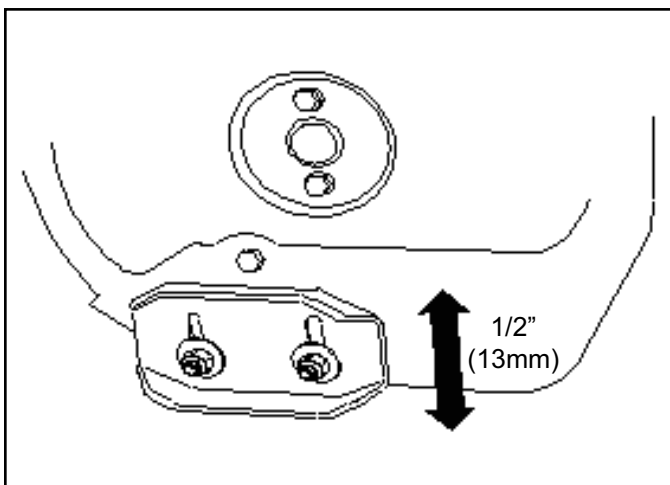

Fig 070

m-6938

4. Adjust the scraper to a minimum of $\frac{1}{8}$ " (3.2mm) above and parallel to a level surface. Secure with carriage bolts and locknuts.
5. Move the skids down until they are even with the ground.
6. Firmly tighten the nuts securing both skids to the auger sides.
7. Check to ensure that the rotating part of the auger does not touch the ground. This can damage the pavement as well as the auger.

Important: If the machine is to be used on rough, broken or uneven pavement, adjust the skids to raise the scraper. For gravel surfaces, adjust the skids further down to prevent the snowthrower from picking up rocks.

Pivoting Scraper

A pivoting scraper is more complex but has advantages when used on paved surfaces. It can be set to scrape down to the surface. Should it hit something solid, it will slide rearward; two springs return it to the operating position once it clears the object. However, use on a gravel driveway may jam or damage the scraper, as rocks can be forced between the scraper and housing. Therefore, the pivoting scraper should not be used on gravel surfaces (Fig. 071).

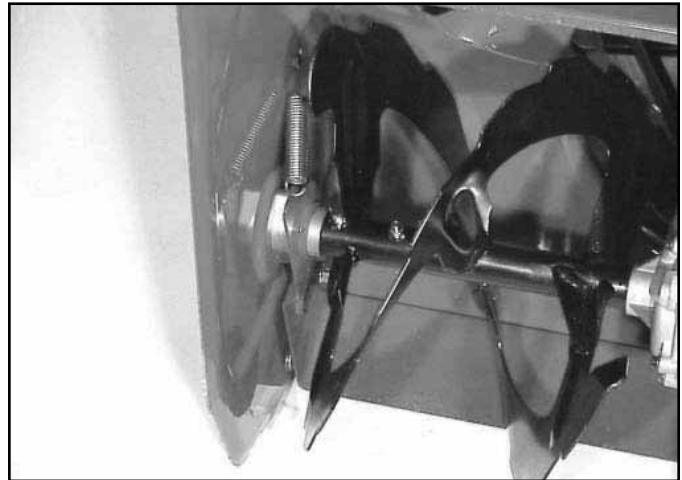

Fig 071

MVC-761X

Scraper Replacement and Adjustment

The scraper pivots on the auger shaft bearings on each side of the auger. It is necessary to remove the auger assembly to replace the scraper. See auger gearbox removal.

Adjusting the Skids and Scraper - Pivoting Scraper Models

1. Check the air pressure in the tires. They must be between 17 and 20 psi (116-137 kPa) and the same on both sides so the machine sets level.
2. Move the snowthrower onto a level surface.
3. Loosen the nuts that secure both skids to the auger sides until the skids slide up and down easily.
4. For use on a smooth paved surface, push down on the handles to raise the auger. This will allow the scraper to move fully forward. Set the auger down so the scraper contacts the ground.
5. Move the skids down until they contact the ground and secure them.

Note: If the surface that this machine will be used on is really smooth, the skids can be raised slightly, approximately 1/8-1/4" (3-6mm) to increase the scraping action.

If you must use a pivoting scraper on a gravel surface, set the skids all the way down, raising the auger to prevent the scraper from picking up rocks.

6. Check to ensure the rotating part of the auger does not touch the ground. This can damage the auger as well as the pavement.

THIS PAGE INTENTIONALLY LEFT BLANK

AUGER GEARBOX

The auger gearbox contains a worm gear and a helical gear. It is driven by a clutched belt from the engine.

The first step in making repairs to the auger gearbox is to remove the auger assembly from the auger housing.

AUGER GEARBOX REMOVAL, PRIMARY METHOD (MINIMUM DISASSEMBLY)

1. (2-cycle models only) Remove the 3 screws connecting the front and rear engine cover. Also remove two screws, one on each side, from the lower rear edge of the front cover. If the front engine cover is loose it will make removing the belt cover much easier (Fig. 072).

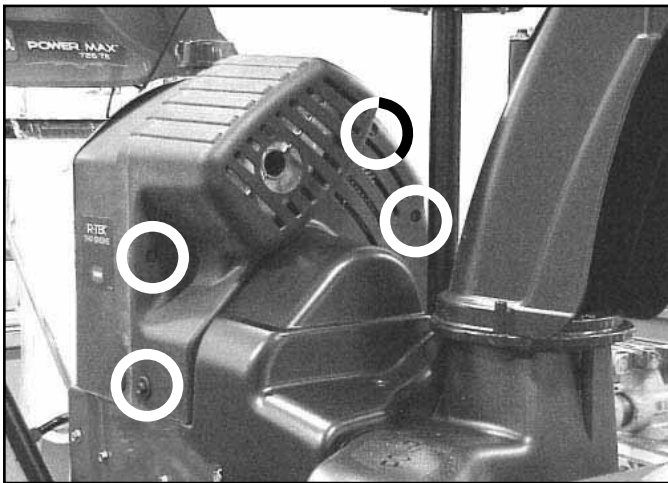

Fig 072

MVC-000

2. (All models) Remove the two-piece belt cover (Figs. 073 and 074).

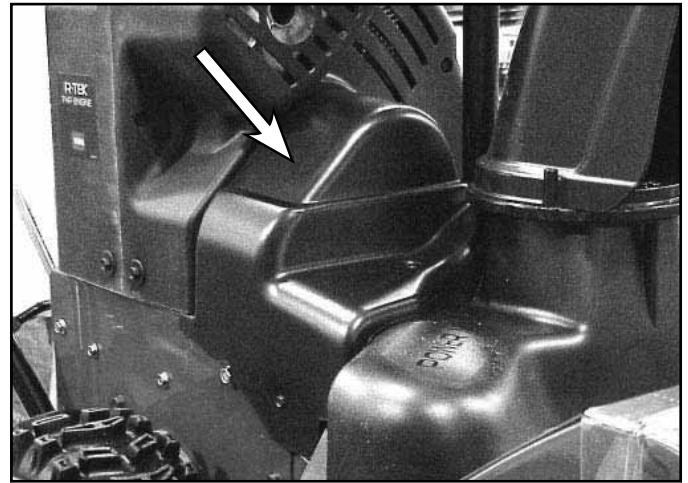

Fig 073

MVC-006XB

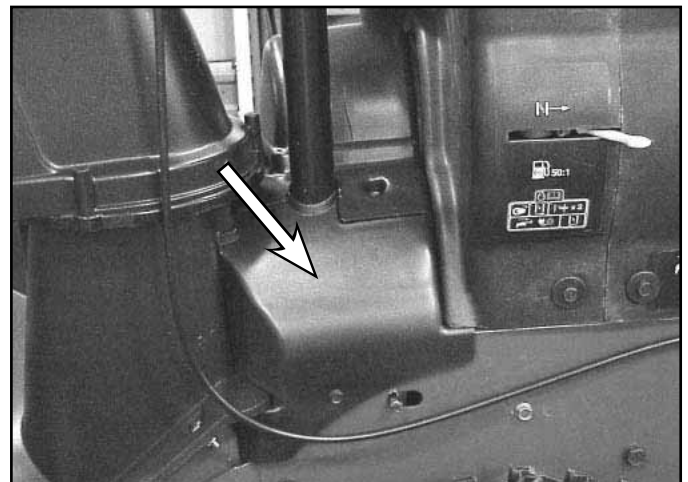

Fig 074

MVC-005X

AUGER GEARBOX

3. Remove the belt guide around the crankshaft pulley (Fig. 075). Be careful to avoid bending the guide.

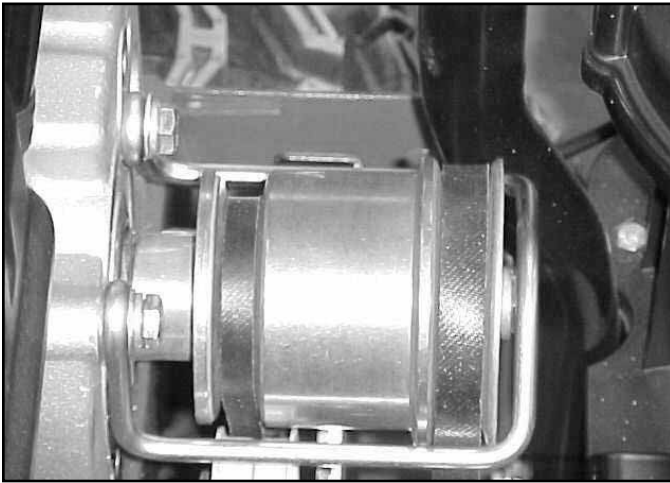

Fig 075

MVC-007F

5. Remove the brake spring (Fig. 077).

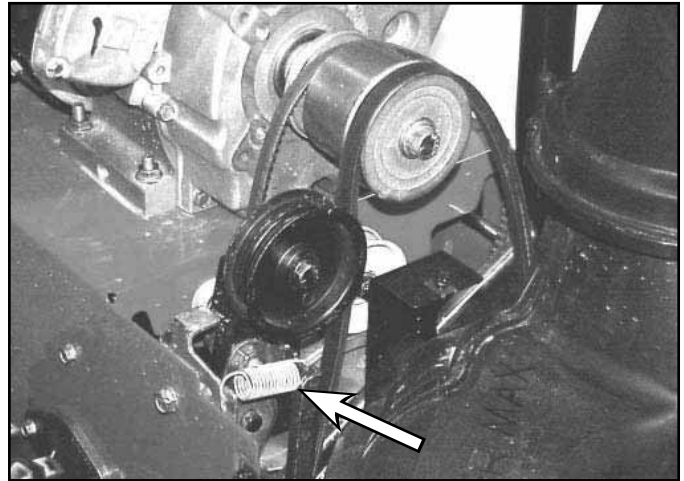

Fig 077

MVC-008X

4. Remove 2 capscrews for the auger brake assembly (Fig. 076).

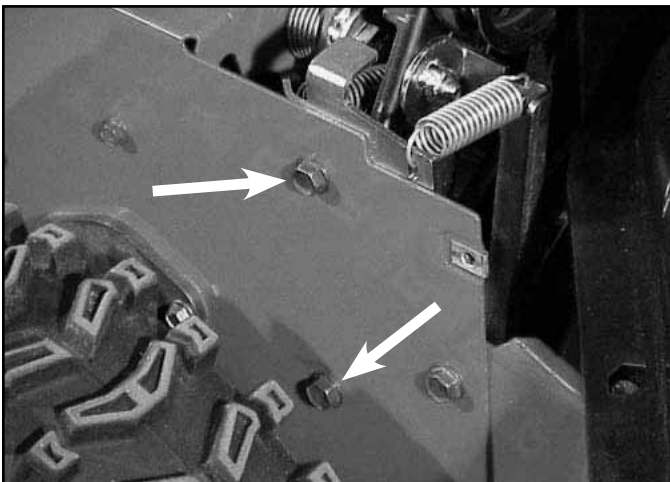

Fig 076

MVC-1883X

6. Remove the auger brake assembly (Fig. 078).

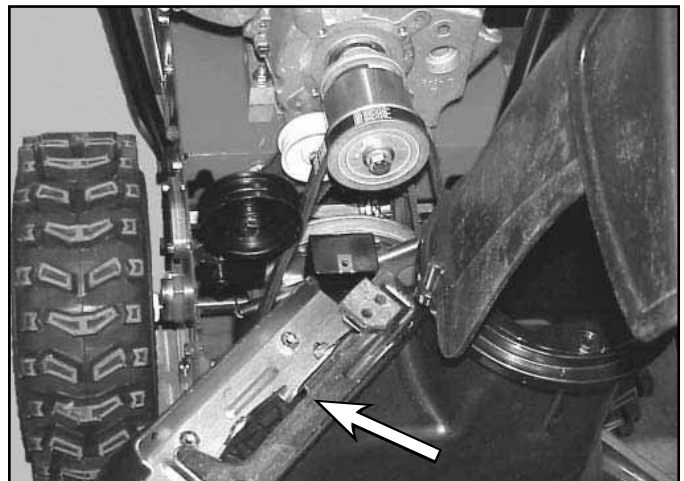

Fig 078

MVC-067X

AUGER GEARBOX

7. Remove the crankshaft pulley capscrew (Fig. 079), the front section of the pulley and the belt.

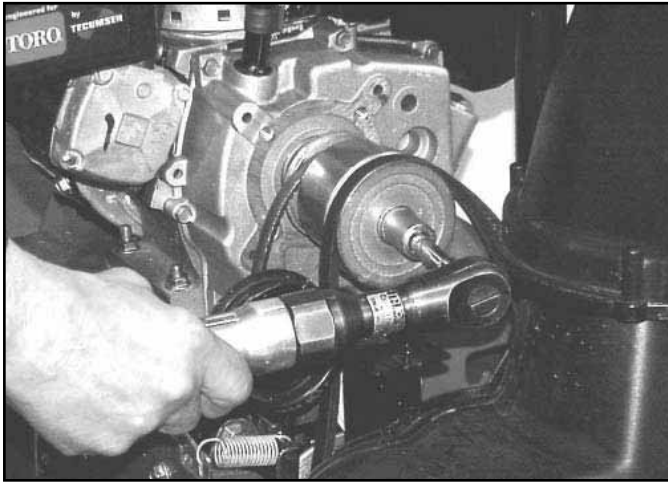

Fig 079

MVC-011X

9. Remove two capscrews on each side that secure the auger bearings to the auger side plate (Fig. 081).

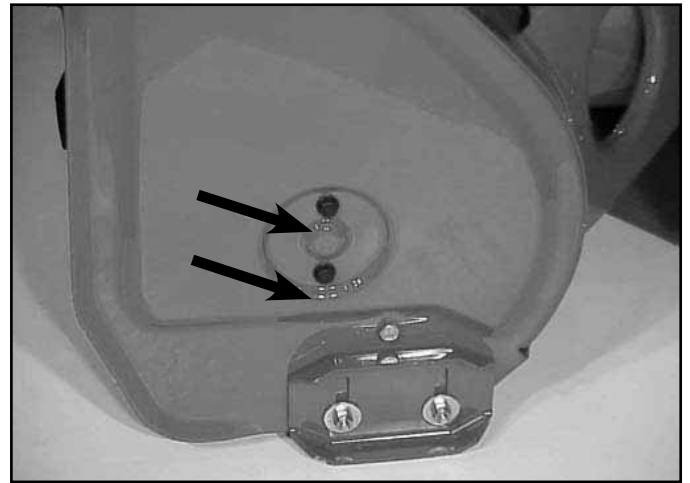

Fig 081

MVC-769X

8. Loosen the 2 set screws on the auger pulley. A long extension and a ratchet will be necessary (Fig. 080).

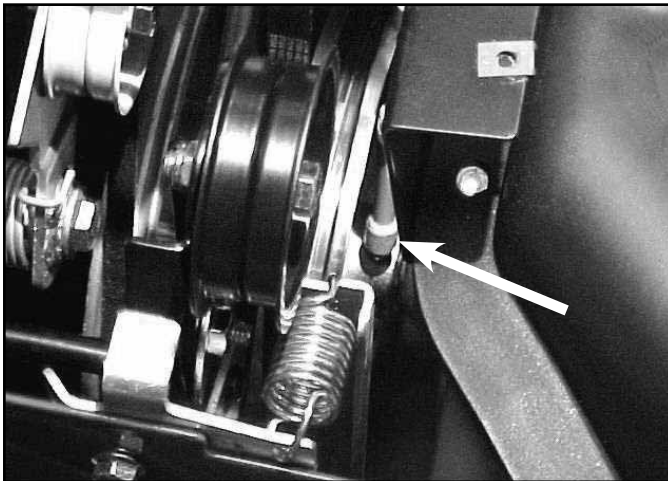

Fig 080

MVC-003F

10. Disconnect the spring on both ends of the pivoting scraper (Fig. 082).



Fig 082

MVC-787F

AUGER GEARBOX

11. Pull the auger forward a little, slide the pulley from the auger gearbox input shaft and pull the key out of the shaft. The auger assembly should pull out to the front.

Note: If you cannot remove the pulley from the input shaft, it will be necessary to separate the auger and traction assemblies to get better access to the auger pulley. See *Separating the Auger and Traction Assemblies*, page 7-4.

12. Slide the bearing off each end of the auger shaft. If this model has a pivoting scraper, it can now be removed.
13. Remove the capscrew connecting each auger to the auger shaft and slide the auger off the shaft (Fig. 083).

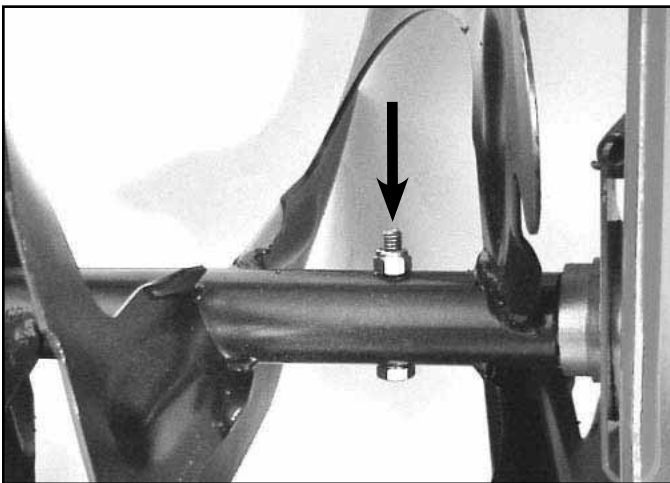

Fig 083

MVC-900XA

14. The auger gearbox is now ready for disassembly and repair.

SEPARATING THE AUGER AND TRACTION ASSEMBLIES SECONDARY METHOD

Should you be unable to remove the pulley from the auger gearbox input shaft, it will be necessary to separate the auger and traction assemblies. After performing steps 1-7 listed above, proceed as follows:

1. Disconnect the deflector cable from the deflector (Fig. 084).

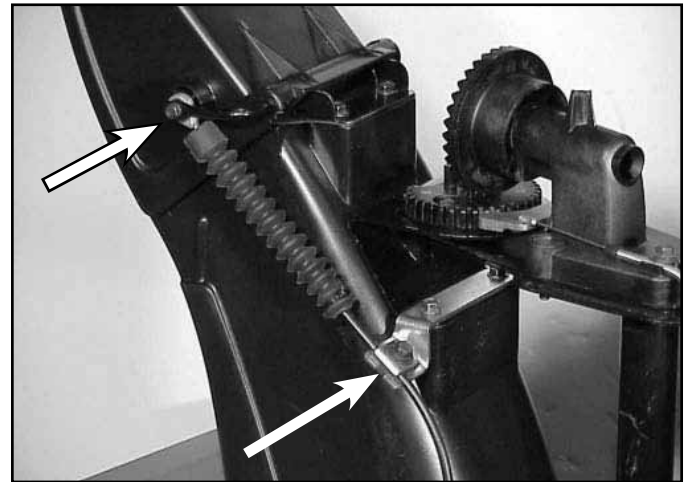

Fig 084

MVC-771X

2. Remove the cover over the chute gears. Free the chute latch cable from its clamp and disconnect the chute latch cable (Fig. 085).

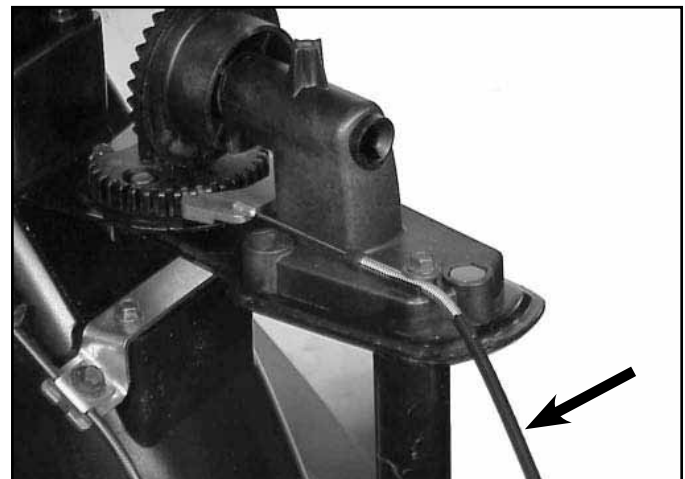

Fig 085

MVC-774X

AUGER GEARBOX

3. Remove the two carriage bolts on the chute control rod (Fig. 086).

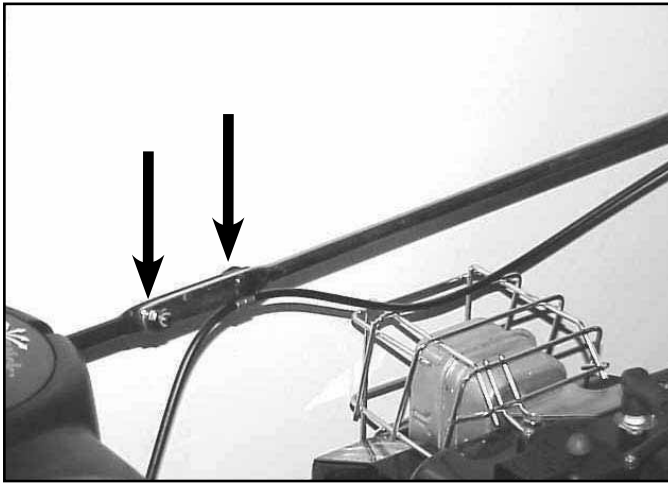

Fig 086

MVC-725F

4. Support the auger and traction with blocks of wood.
5. Remove three capscrews down each side connecting the auger to the traction assembly and separate the sections (Fig. 087).

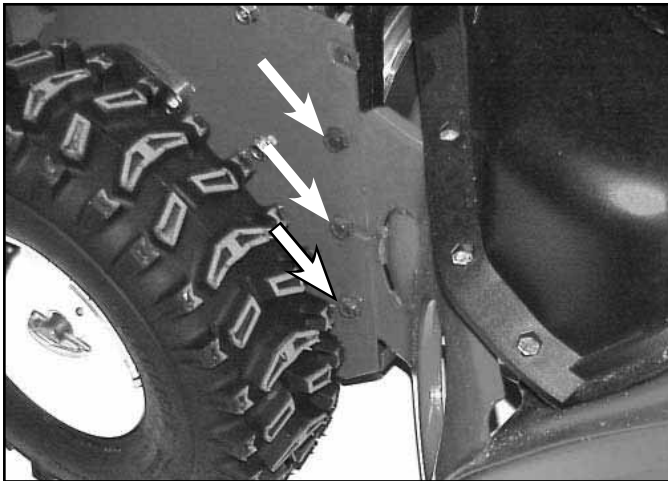

Fig 087

MVC-1135X

6. Once separated, the auger pulley is in the open. Once the pulley and key have been removed, perform the preceding steps 12-14 to complete auger removal.

GEARBOX INSTALLATION

1. Apply a light coat of anti-seize to the auger shafts and the impeller shaft. Install the impeller and augers and secure with the capscrews and locknuts. On models with the pivoting scraper, install the scraper over the ends of the auger shaft. Slide the auger shaft bearings on the ends of the auger shaft.
2. Insert the impeller shaft through the bearing in the rear of the auger housing. The bearing mounting bolts should be slightly loose at this time. (Note: if the auger and traction assemblies are connected, apply a light coat of anti-seize to the impeller shaft and install the auger pulley at this time. If not, the pulley can be installed in step 5.)
3. Secure the auger shaft bearings to the auger side plates with 2 capscrews on each side. On models with the pivoting scraper, install the scraper springs.
4. To ensure the impeller shaft bearing has aligned itself with the shaft, strike it a couple of times with a rubber mallet. If the auger and traction assemblies are not separated, use a block of wood. Place it on the auger shaft and strike the wood with a hammer. The jolt to the shaft aligns the bearing. Secure the bearing.
5. Apply a light coat of anti-seize to the impeller shaft and install the impeller pulley. Push the auger shaft to the rear and push the pulley forward and secure. There should be no more than 1/8" (3mm) front to back movement in the shaft.

AUGER GEARBOX

AUGER GEARBOX REPAIR

Lubrication

The proper lubricant is 90-weight gear oil. A multi-weight such as 85-120 is acceptable as long as it encompasses the 90-weight rating. The oil must also have an extreme pressure (EP) rating of GL5 or higher. With the gearbox setting approximately level, fill until oil runs out of the fill/check plug. Total capacity is about 4 oz. (118ml).

Gearbox Disassembly and Repair

1. All models use a cap screw and locknut to secure the augers to the auger shaft. Remove the cap screw and slide the auger off of the shaft (Fig. 088).

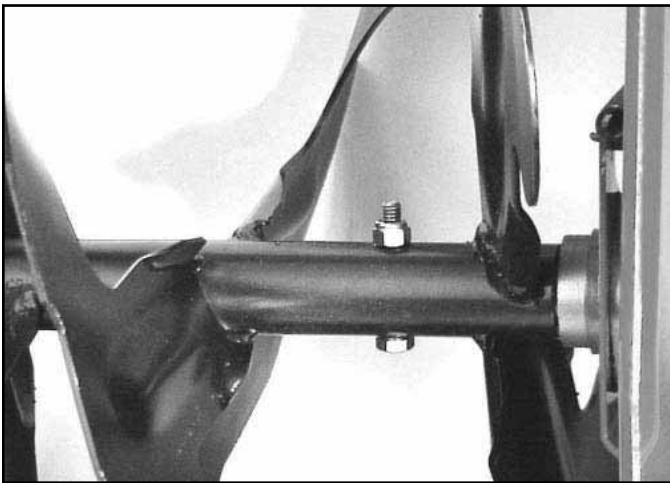

Fig 088

MVC-900XA

2. The impeller is attached to the impeller shaft with two cap screws and locknuts. Remove the cap screws and slide the impeller off of the shaft.
3. Even if you have drained the oil, we recommend supporting the gearbox over a drain pan when you separate the case halves. Remove the screws and separate the case halves.

4. The impeller shaft can now be removed (Fig. 089).

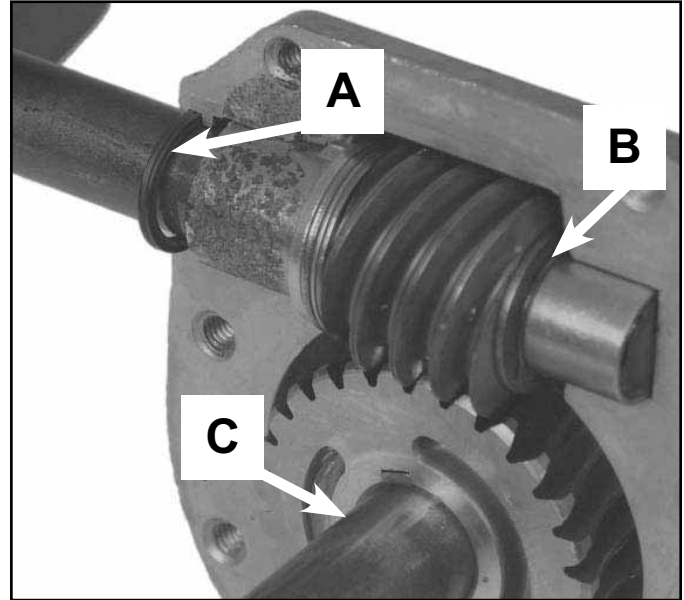

Fig 089

DSC-0061

- A. Ring
B. Impeller Shaft/Worm
C. Worm gear

5. Clean the output shaft and slide the case halves off. Remove and discard the seals.
6. Clean and inspect the auger shaft bushings in the case halves. If they are damaged or worn, press them out of the case halves at this time.
7. Slide the worm gear off of the shaft. Remove the woodruff key.
8. Slide the bushing, thrust washers, thrust bearing, snap ring, and seal from the impeller shaft.

AUGER GEARBOX

9. Now inspect the worm and worm gear. If either are damaged replace them both. When gears run together, they develop wear patterns unique to the two of them. Replacing only one gear will result in early failure (Fig. 090).

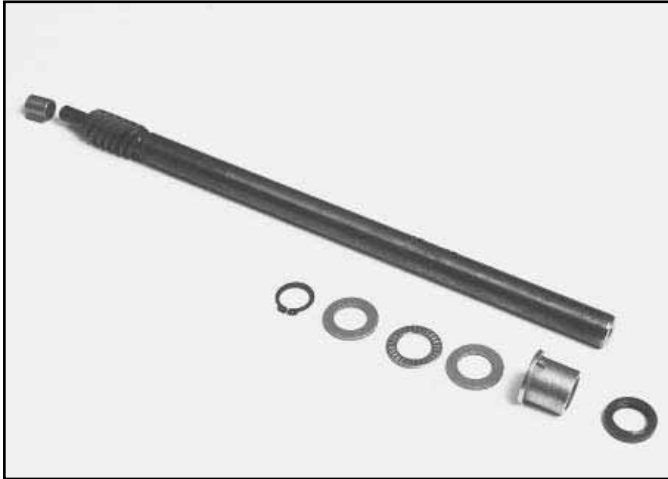

Fig 090

DSC-0028

Failure Analysis

The square cut ring on the impeller shaft is not an oil seal. It is a wiper ring that has a tendency to pull down to the shaft when the shaft begins to turn. The bushing next to the ring deflects most of the oil that is thrown towards that area. The loose fit provides a vent for the case (Fig. 091).

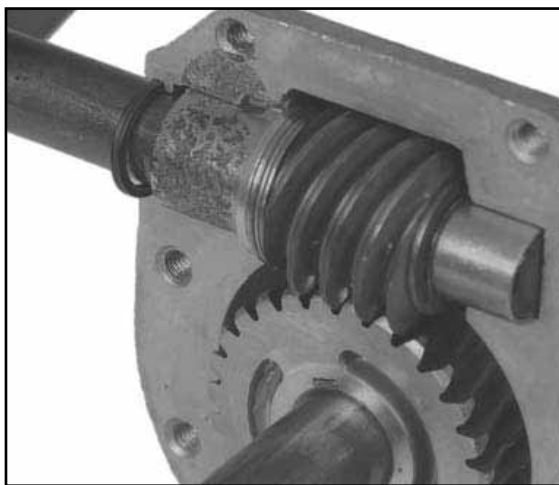

Fig 091

DSC-0061

Occasionally a drop of two of oil will get between the bushing and ring. When the auger drive is disengaged, the ring will relax and that oil might drip into the auger housing. At this rate the machine can be used for several years without any significant oil loss. The yearly oil check is more than adequate to compensate for this.

If there is a significant amount of oil coming out of this area, it would indicate that the gearbox has been at a severe operating angle or the bushing is badly worn.

Oil on the bottom of the gearbox can result from a leak on any part of the case. As there is no internal pressure, any leaking oil runs down the side of the case and collects on the bottom until there is enough to drip off. The source of the leak can be difficult to see. Sprinkling some powder on the outside of the gearbox will usually show the oil trail. The type of powder used is not important. Just something that will stick to the oil.

When you open a gearbox that has had the gears fail, the remaining oil will likely appear as a small puddle of very thick grease in the bottom. Worm gears normally create friction due to their sliding action. When something goes wrong, not enough oil, poor quality oil, a problem with the gears, or just a gear or bearing wearing out, the friction becomes abnormally high. The remaining oil is cooked down to a very thick residue. This can be the result of a failure, not the cause.

AUGER GEARBOX

Gearbox Assembly

1. Use a wire brush or fine sandpaper to clean the auger shaft. A clean, smooth shaft will help avoid damage when installing new bushings and seals. Clean the old seal material from the case mating surfaces. Scrape, then use liquid gasket remover. (Fig. 092).

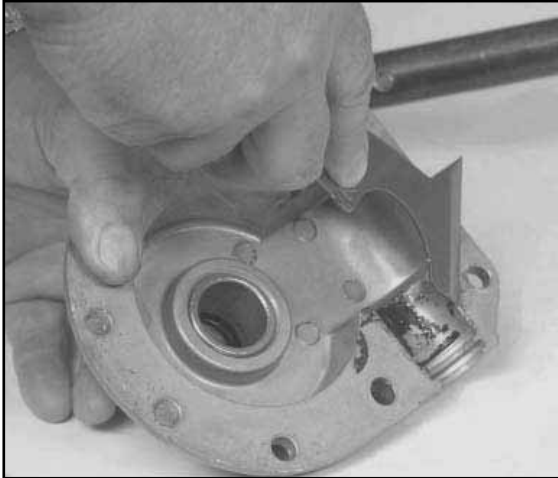

Fig 092

DSC-1167

3. Insert the key into the shaft and slide the worm gear into place. **Note:** There is a large letter R and an arrow stamped into the side of the gear. This gear **MUST** be installed such that the R and the arrow are on the right hand side and the arrow is pointing forward, from the operator's point of view (Fig. 094). This is a two-piece gear that is bonded together. If it is installed backwards, the forces try to separate the gear and can result in failure.

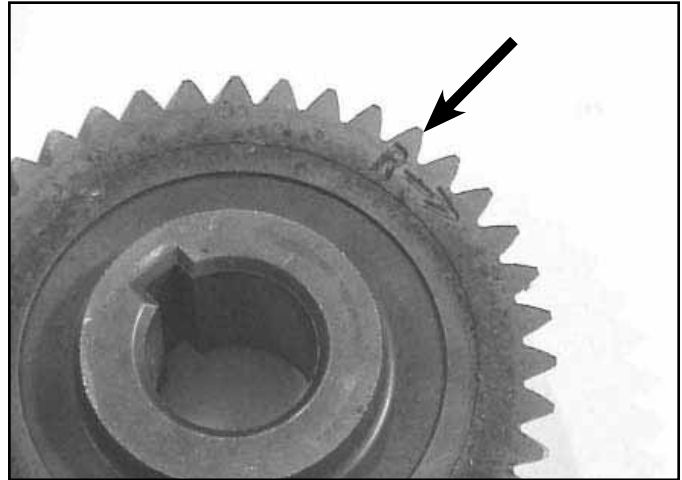

Fig 094

MVC-047X

2. If new bushings are to be installed in the gear case halves, now is the time. Apply a thin coat of Loctite Blue #242 or equivalent to the **OUTSIDE** of the bushing and press in flush with the **INSIDE** of the case (Fig. 093). This will allow space for the seal on the outside. Wipe up any Loctite that is visible. The Loctite must not get into the gear or seal area.

4. Install the thrust washers and slide the case halves on. Note the direction to keep the gear markings on the right side.

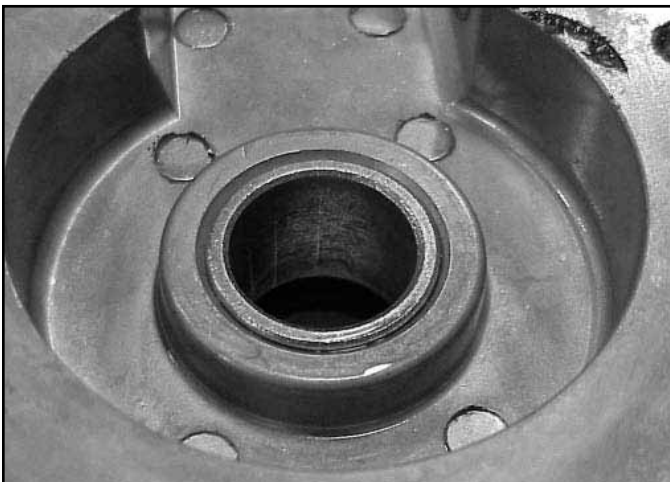

Fig 093

MVC-710X

AUGER GEARBOX

5. To assemble the worm shaft, start with the end opposite the worm. Install a snap ring (sharp edge towards the rear of the gearbox), thrust washer, thrust bearing, thrust washer, bushing and seal. There is also a bushing on the worm end of the seal (Fig. 095).



Fig 095

DSC-0028

6. Apply a VERY light coat of Loctite Blue # 242 or equivalent to the outer diameter of the bearing. The Loctite should not squeeze out when everything is tightened or you used too much (Fig. 096).

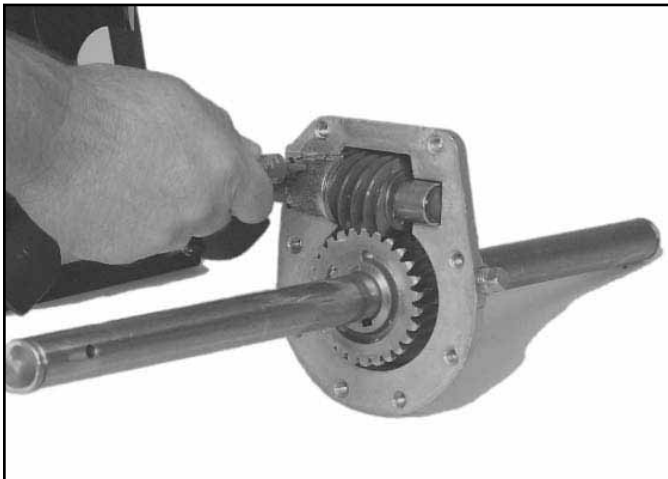

Fig 096

DSC-0059

7. Clean the case halves by scraping; then apply a liquid gasket remover. To ensure a good seal case halves must be clean and dry. Apply a thin coat of Hylomar (Toro PN 505-129) to **both** halves. Allow it to cure until it is dull and tacky, at least one hour. Then assemble.
8. Apply a light coat of oil or anti-seize to the gear case screws. Tighten them in an X pattern to 120 in-lbs. (15kg/m) (Fig. 097).

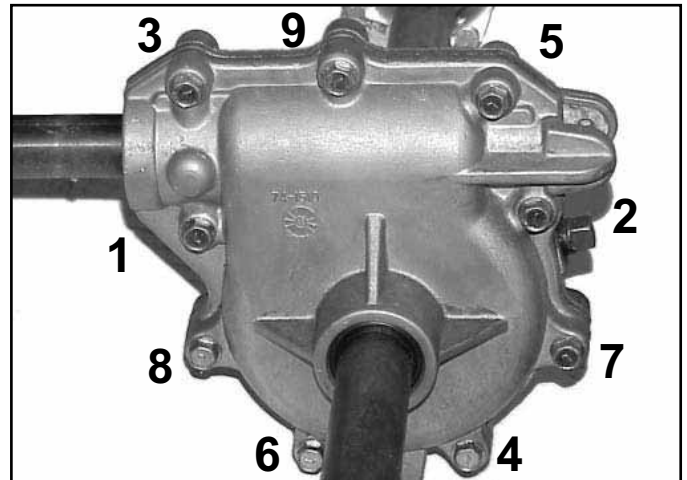

Fig 097

MVC-844XA

9. Lightly oil a seal protector and slide new seals down the auger shaft. The lip of the seal should face towards the inside. Seat the seals so the outer edge is just flush with the outside of the gearcase.

THIS PAGE INTENTIONALLY LEFT BLANK

NON-WHEEL CLUTCH TRACTION DRIVE SYSTEM

GENERAL DESCRIPTION

The traction drive system begins with a belt from the engine crankshaft to a combination pulley/drive plate. The belt is tensioned by a spring loaded idler so the pulley/drive plate rotates whenever the engine is running (Fig. 098).

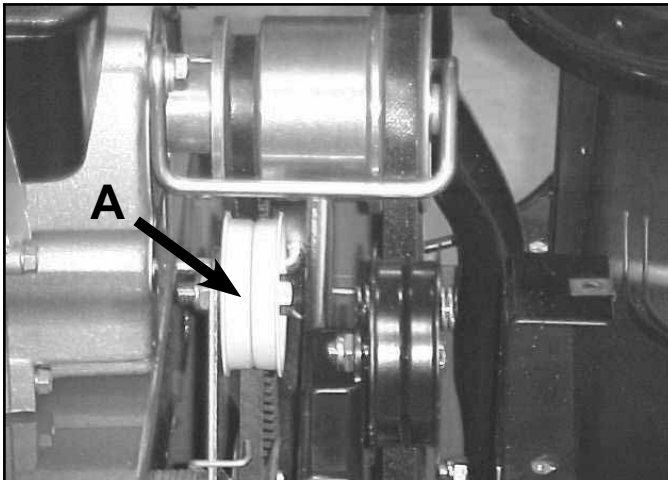

Fig 098

MVC-009F.jpg

A. Idler

Perpendicular to the drive plate is a rubber coated friction wheel. In neutral there is a gap between the plate and wheel. When the traction bail is squeezed the drive plate pivots to the rear and begins to drive the friction wheel. This in turn causes the hex shaft, chain, gears and axle to rotate. The direction of rotation and speed are determined by the point on the drive plate the wheel makes contact. Moving the wheel from side to side will change direction of rotation and the farther out from center the wheel contacts the plate, the faster the speed.

In forward the wheel will contact the left side of the drive plate (Fig. 099).

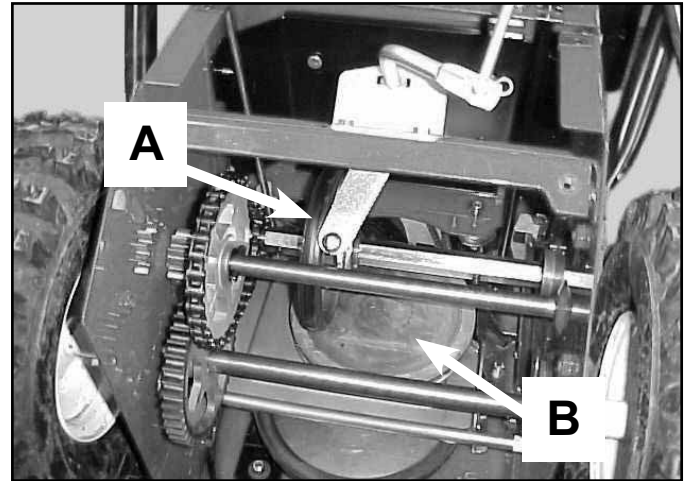

Fig 099

MVC-003A.jpg

A. Friction Wheel B. Drive Plate

Disassembly

To disassemble the traction drive assembly, proceed as follows:

1. Drain the fuel tank and stand the unit on end. Remove the belt covers.

NON-WHEEL CLUTCH TRACTION DRIVE SYSTEM

2. Remove the upper and lower covers and bottom pan (Fig. 100).

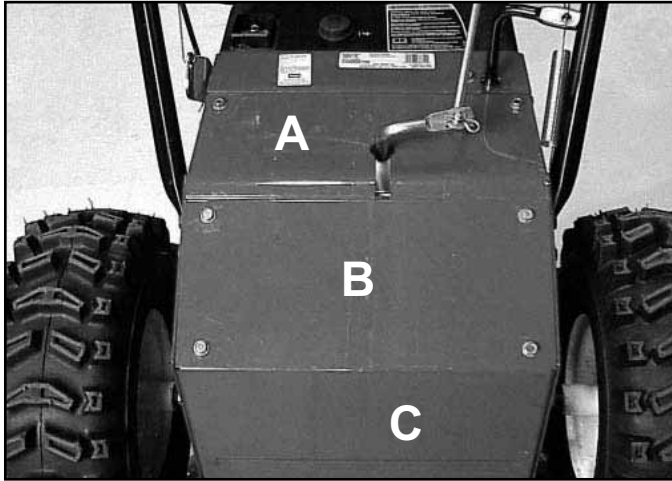

Fig 100

MVC-9012X.jpg

- A. Upper Cover
B. Lower Cover
C. Bottom Pan

3. Remove the screw securing each end of the sprocket shaft (Fig. 101).

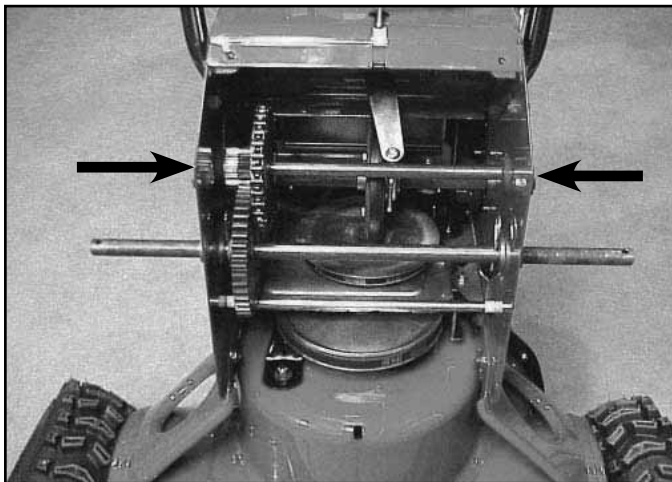

Fig 101

MVC-9022X.jpg

4. Pull the right hand end of the shaft out of the traction housing. Optional: The chain contains a master link, which also can be removed (Fig. 102).
5. Slide the shaft out of the sprocket, slip the chain off, then remove the sprocket.

Note: There is a thrust washer that may stick to the bushing on the sprocket (Fig. 102).

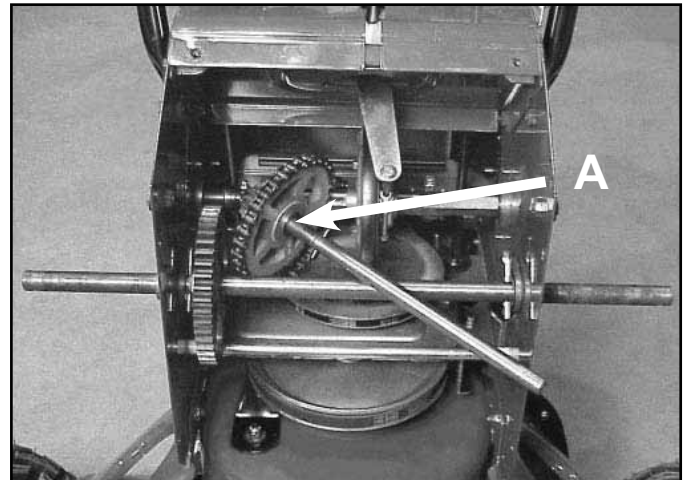

Fig 102

MVC-771X.jpg

- A. Thrust Washer

NON-WHEEL CLUTCH TRACTION DRIVE SYSTEM

6. Remove the large hairpin on either end of the axle (Fig. 103).

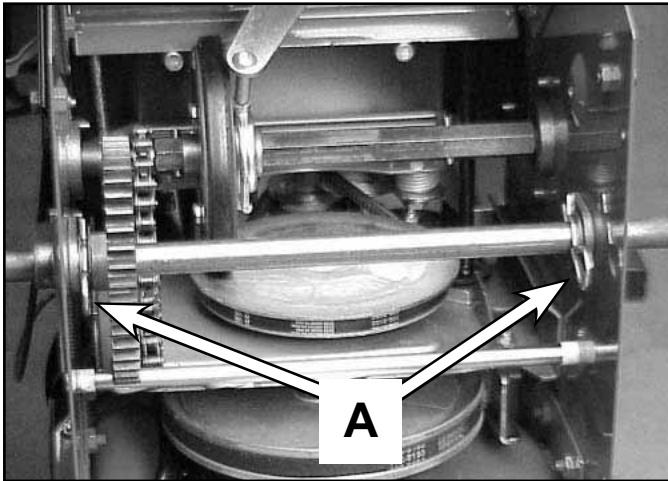

Fig 103

MVC-1900X.jpg

A. Hairpin Cotter

8. Remove the two capscrews securing the bearing retainers to each side of the traction frame. Slide the bearings and retainers off the hex shaft (Fig. 105). The bearings are secured to the retainers with Loctite and are replaced as an assembly.

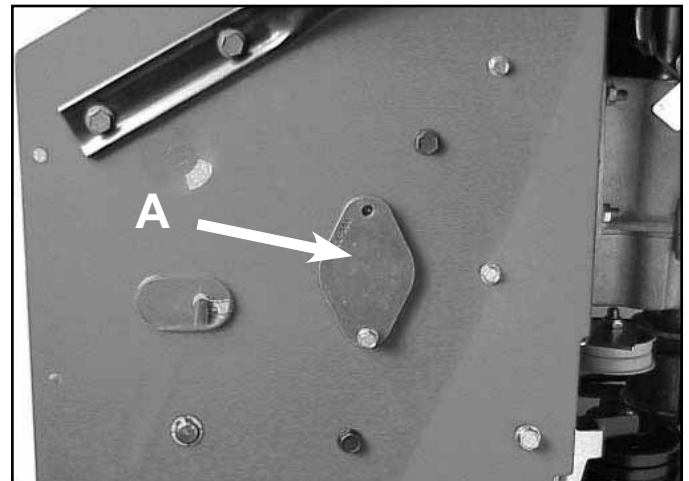

Fig 105

MVC-864XYZ.jpg

A. Bearing Retainer

7. Slide the axle a little to the right. Move both axle bearings inward (Fig. 104) then slide to the right until the left end of the axle comes out of the side plate. Withdraw the axle and remove the thrust washers, bearings, gear and key.

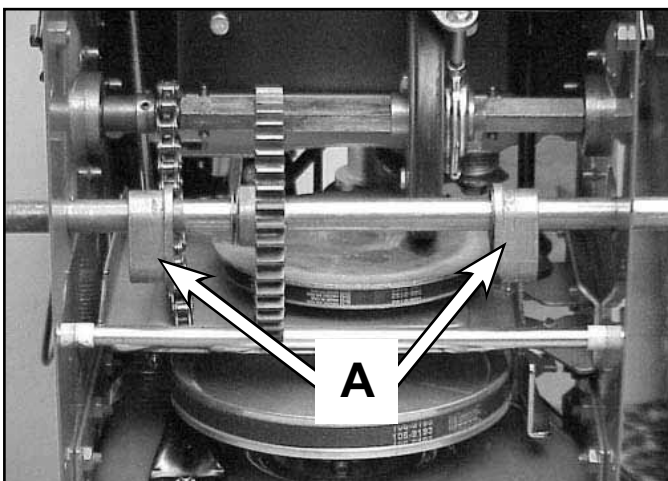

Fig 104

MVC-1904X.jpg

A. Axle Bearing

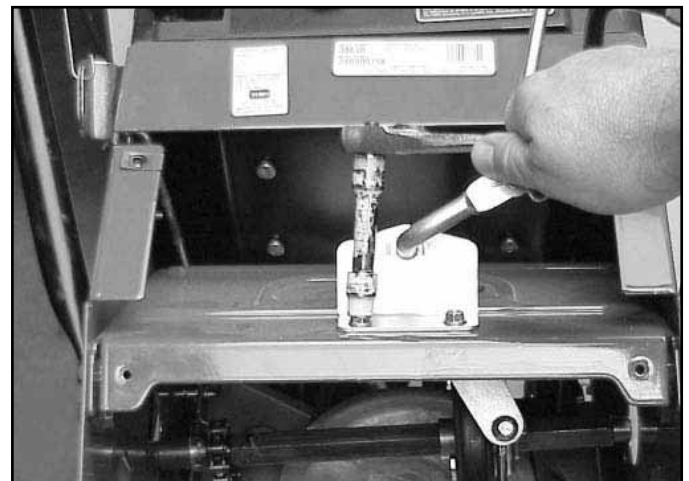

Fig 106

MVC-1001X.jpg

NON-WHEEL CLUTCH TRACTION DRIVE SYSTEM

10. Now the shift rod bracket and hex shaft can be moved to separate the shift rod from the trunion (Fig. 107).

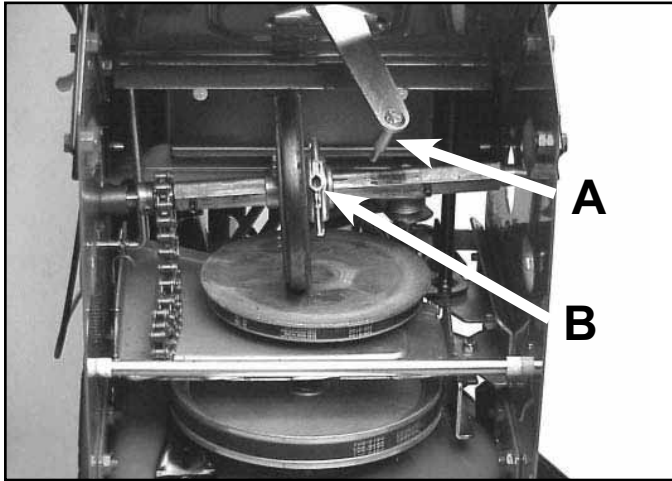

Fig 107 MVC-1002X.jpg

A. Shift Rod B. Trunion

At this point the friction wheel can be replaced. The hex shaft, sprocket, trunion and spacers are a single assembly.

11. Remove the hairpin from the speed control link (Fig. 108). This is most easily accessed from the top of the machine. The link is on the left side under the belt cover. Slide the link out of the pulley pivot assembly.

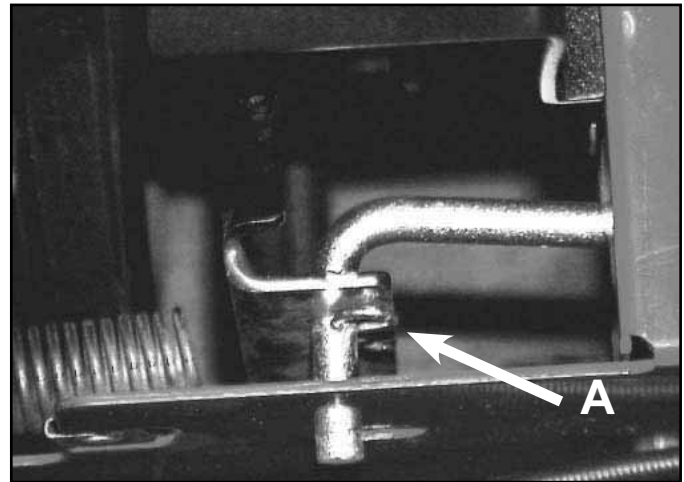

Fig 108 MVC-897X.jpg

A. Hairpin Cotter

12. Slip the traction idler off the traction belt. This can be done from either the top or the bottom. The traction idler will rotate to this position (Fig. 109).

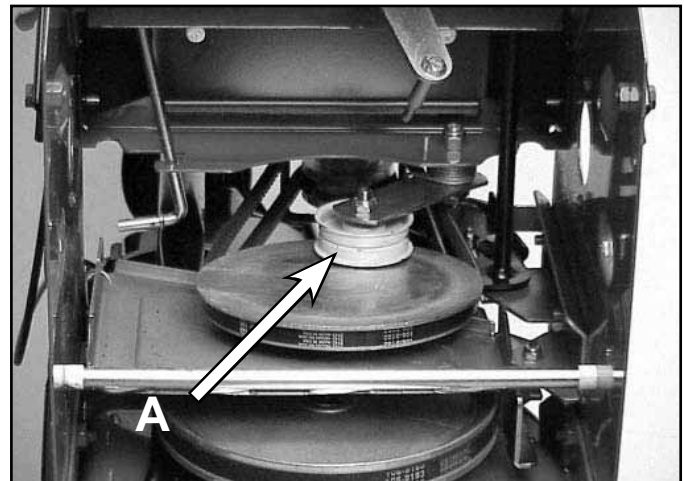

Fig 109 MVC-1003X.jpg

A. Traction Idler

NON-WHEEL CLUTCH TRACTION DRIVE SYSTEM

13. Remove the snap ring from both ends of the pulley pivot assembly shaft (Fig. 110). The nylon bushings can be removed now or when the pulley pivot assembly is removed.

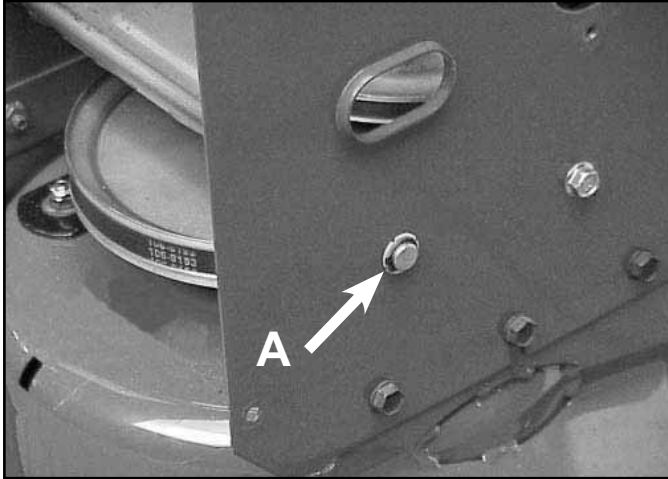

Fig 110

MVC-1004X.jpg

A. Snap Ring

14. Reach up to the far left corner of the pulley pivot assembly and unhook the spring from the pivot assembly (Fig. 111).

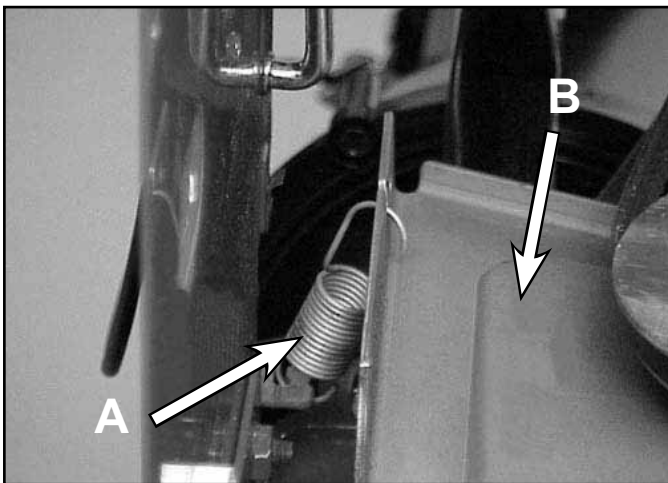

Fig 111

MVC-1005X.jpg

A. Spring

B. Pivot Assembly

15. Slip the belt off of the pulley and slide the pivot assembly to the side to remove the rod ends from the side plate (Fig. 112).

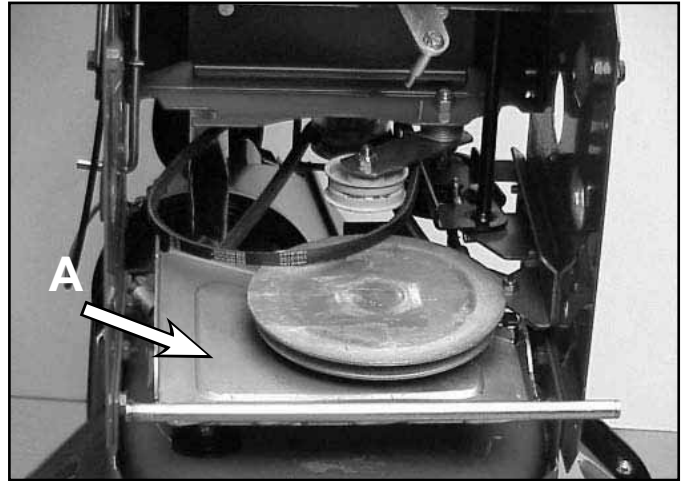

Fig 112

MVC-1007X.jpg

A. Pivot Assembly

16. To separate the pulley from the pulley pivot assembly use a box end wrench and screwdriver to loosen the nut (Fig. 113).

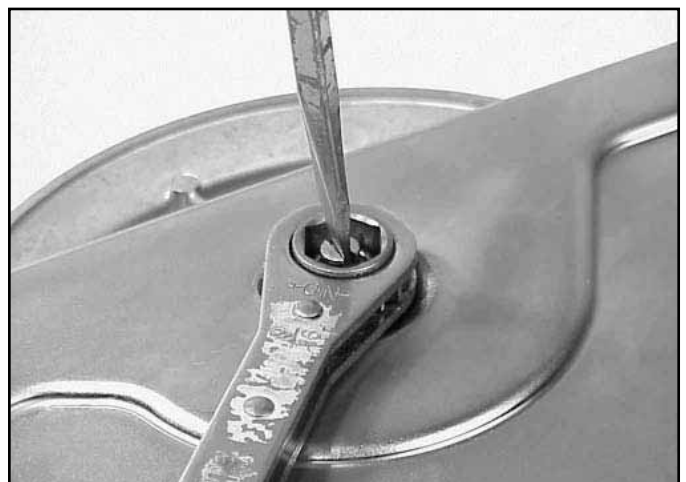

Fig 113

MVC-870XB.jpg

NON-WHEEL CLUTCH TRACTION DRIVE SYSTEM

Reassembly

Reassemble in reverse order.

Reassembly notes:

1. If you removed the master link from the chain, it must be assembled with the closed end of the master link going in the direction of rotation in forward gear (Fig. 114).

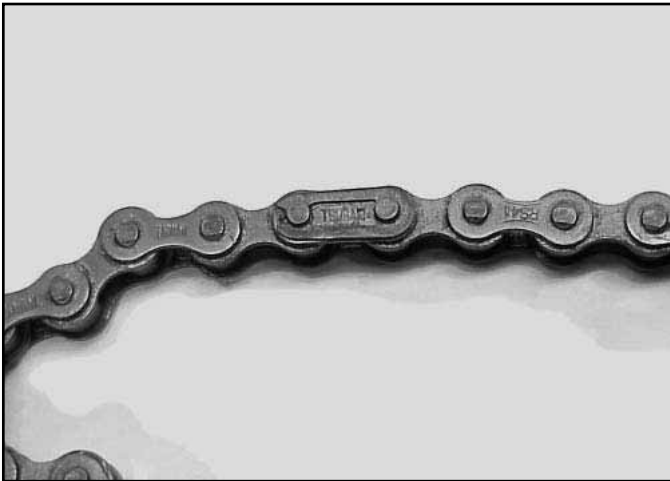

Fig 114

MVC-051X.jpg

2. Fastener Torque
 - A. All fasteners seated against plastic should be securely tightened but not deform the plastic.
 - B. Self tapping screw for the ends of the intermediate shaft. 170 - 300 in-lbs. (196 - 345kg/com).
3. Lubrication
 - A. Light coat of engine oil to intermediate shaft.
 - B. Apply light coat of anti-seize to outer 5" of axle shaft (circumference of 44 tooth axle gear).

WHEEL CLUTCH TRACTION DRIVE SYSTEM

GENERAL DESCRIPTION

The Freewheel Steering system is used on 28" models. Handle mounted triggers allow clutching the wheels simultaneously or independently, so one or both wheels can "freewheel." This feature makes turning, reversing, and traction control simple and efficient.

When the drive is engaged, it is engaging the friction wheel. The hex shaft turns and drives the chain(s) to the 32 tooth gear in turn driving the 44 tooth gear powering the wheels. Each wheel is declutched by engaging its handle mounted trigger; this pulls the clutch cable, which rotates the shift collar. The shift collar, following a cam, is forced outwards, toward the wheel, in turn, pushing into the spring loaded pawls to disengage the 11 tooth pinion gear from the 32 tooth gear.

DISASSEMBLY

1. Disconnect shift linkage and remove tires (Fig 115).

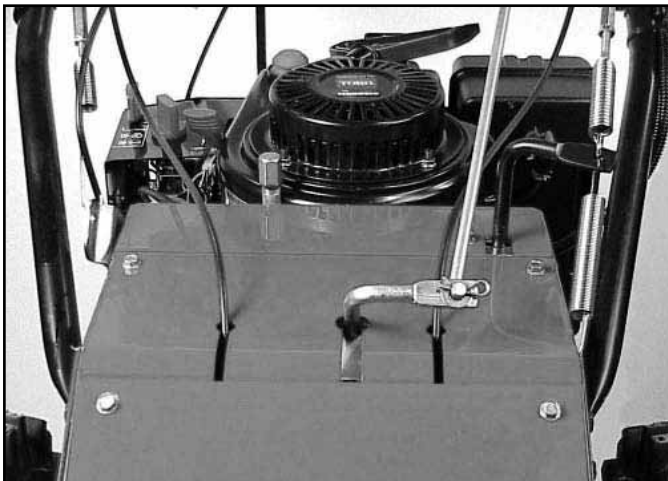

Fig 115

MVC-889X.jpg

2. Remove upper and lower covers (Fig. 116).

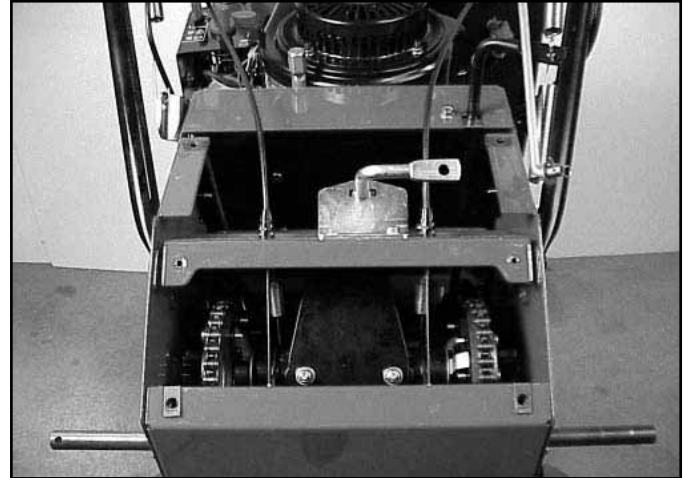

Fig 116

MVC-892XB.jpg

3. Remove bottom plate (Fig. 117).

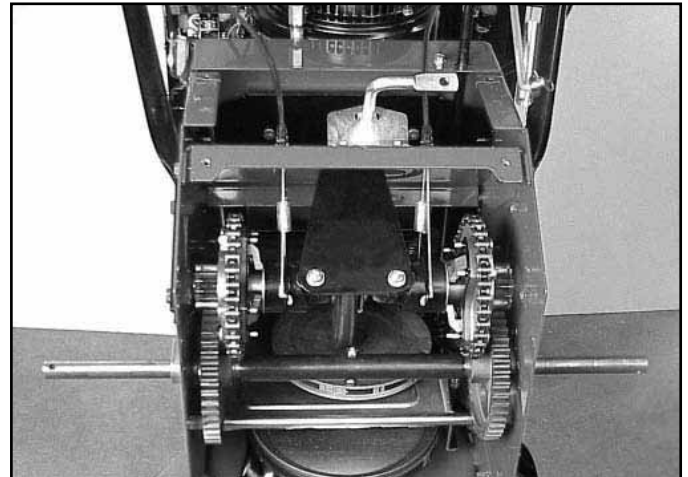

Fig 117

MVC-893XB.jpg

WHEEL CLUTCH TRACTION DRIVE SYSTEM

4. Remove 2 cap screws securing the bearing retainers that hold the hex shaft to each side of the traction assembly and remove both bearing retainers (Fig. 118).

Note: This will ease removal and reinstallation of the drive chains.

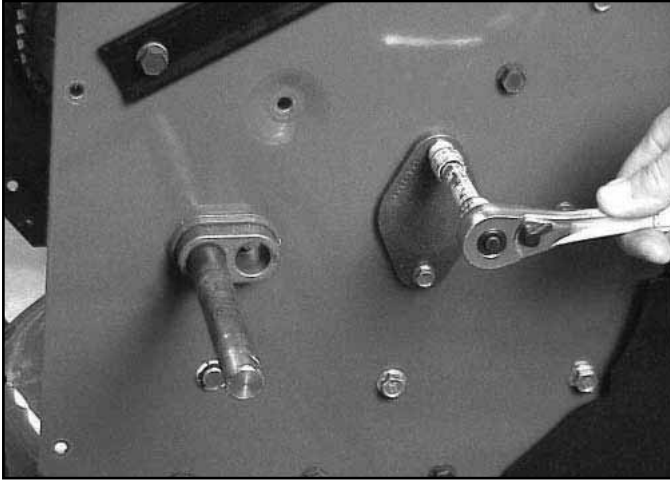

Fig 118 MVC-786.jpg

5. Remove both bolts that hold the wheel clutch assembly to the housing (Fig. 119).



Fig 119 MVC-895X.jpg

6. Remove extension spring - Unhook spring from lower clutch collar and housing (Fig. 120).

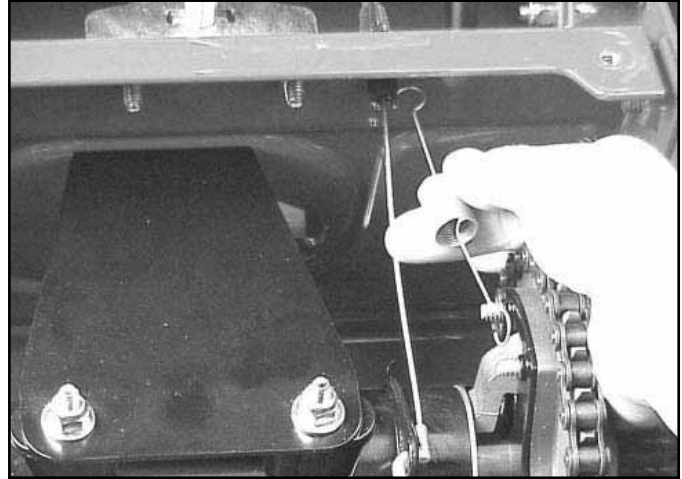

Fig 120 MVC-897springX.jpg

7. Remove clutch cables - Rotate the shift collar up to release tension on the clutch cable and maneuver Z bend of the cable end out of the upper clutch collar (Fig. 121).

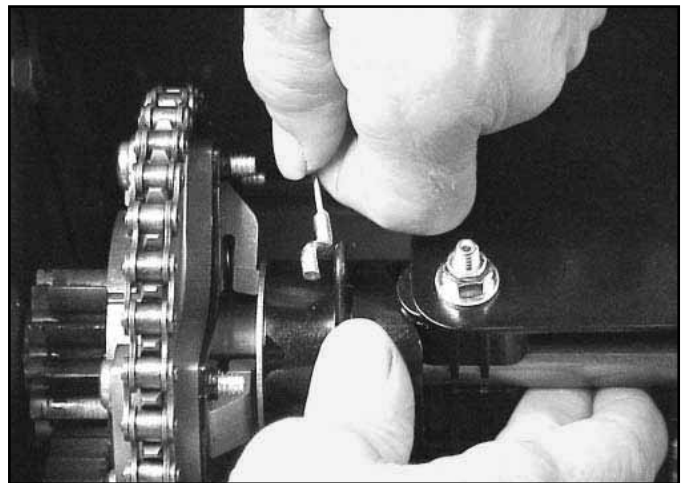

Fig 121 MVC-898XB.jpg

WHEEL CLUTCH TRACTION DRIVE SYSTEM

8. Unbolt upper end of shift brace from housing (Fig. 122 and 123).

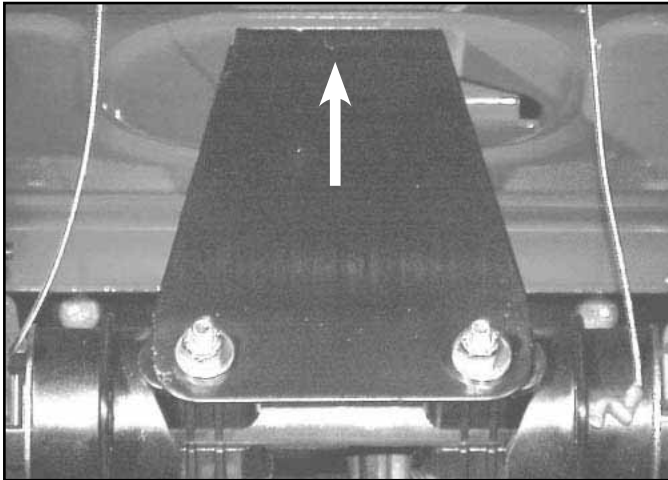

Fig 122

MVC-2200X.jpg

9. Remove both roller chains from 32-tooth gears and lift wheel clutch assembly from traction unit (Fig. 124).

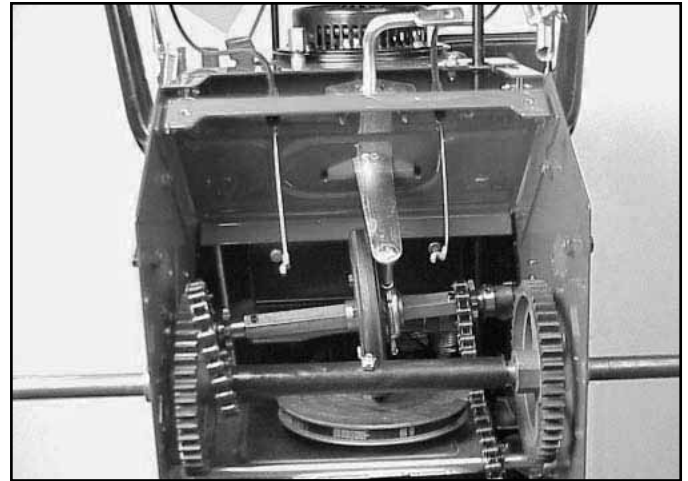

Fig 124

MVC-900XC.jpg

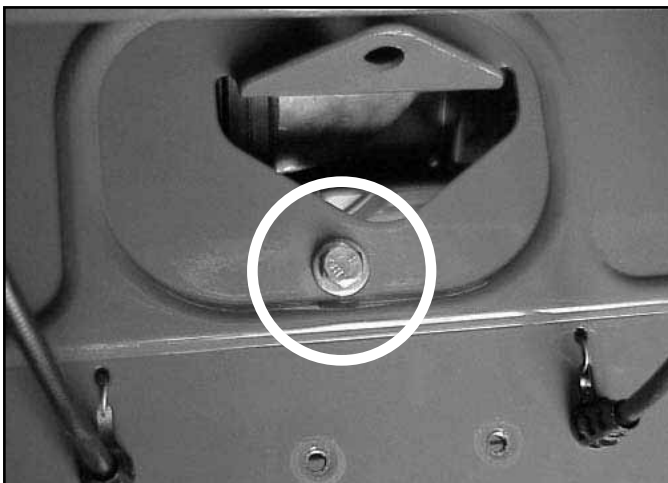

Fig 123

MVC-894XYX.jpg

Note: Install a screw and washer into each end of the shaft to keep the parts from sliding off (Fig. 125).

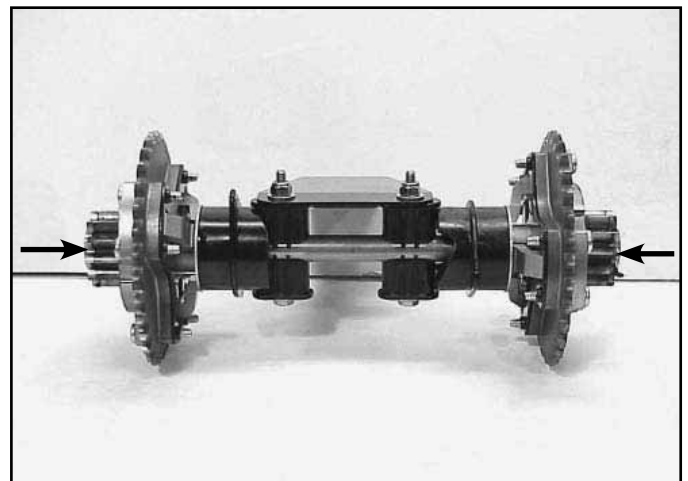

Fig 125

MVC-901XB.jpg

To continue with disassembly of the clutch mechanism, go to page xx.

WHEEL CLUTCH TRACTION DRIVE SYSTEM

10. Remove both hairpins on either side of the axle of 44-tooth gear (Fig. 126).

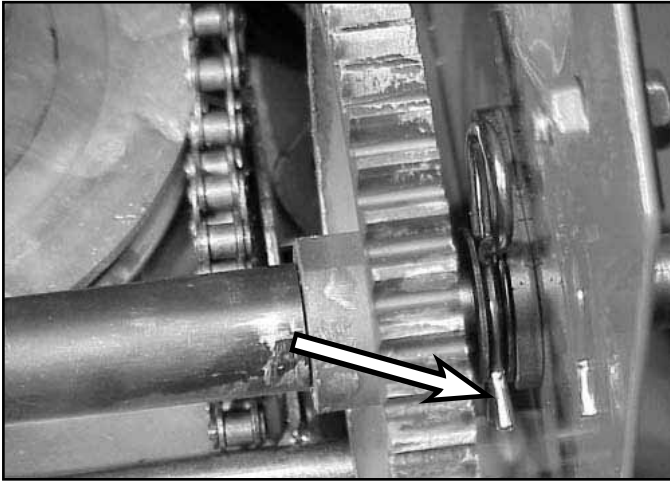

Fig 126

MVC-853X.jpg

12. Slide axle shaft out through bearing retainer one at a time, holding onto the 44 tooth gear (Fig. 128).

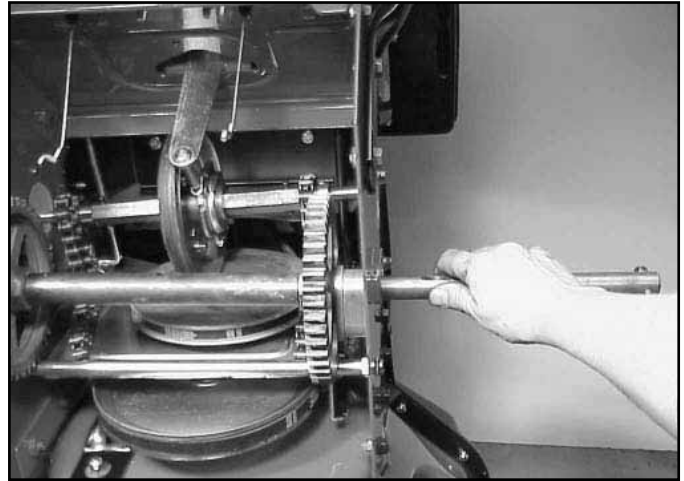

Fig 128

MVC-858X.jpg

11. Remove woodruff key from one side of axle shaft by sliding the 44-tooth gear inward towards the center of the shaft to expose the woodruff key. Pry up on the outside edge of the key to remove it (Fig. 127).

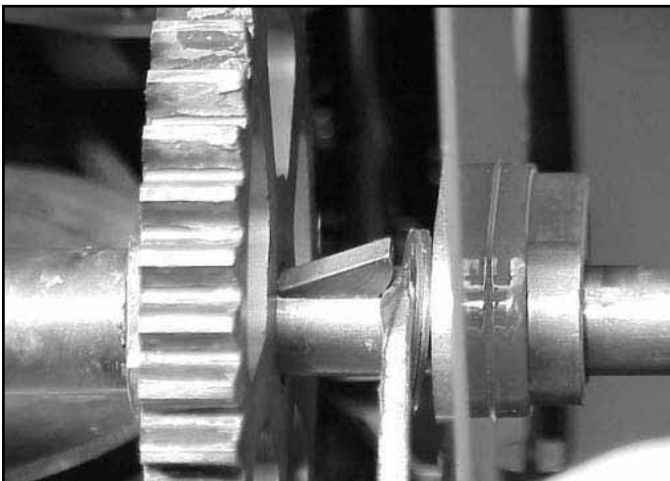

Fig 127

MVC-856X.jpg

13. Slide tube of axle shaft through housing (Fig. 129).

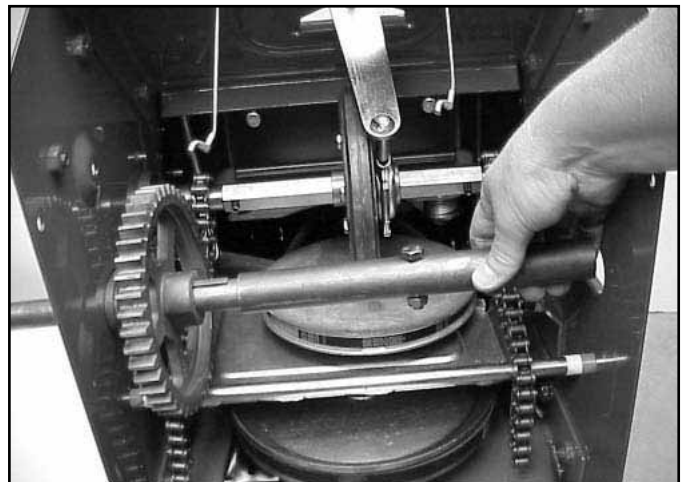

Fig 129

MVC-859XYZ.jpg

WHEEL CLUTCH TRACTION DRIVE SYSTEM

14. Now you can remove the other half of the axle shaft with the 44-tooth gear (Fig. 130).

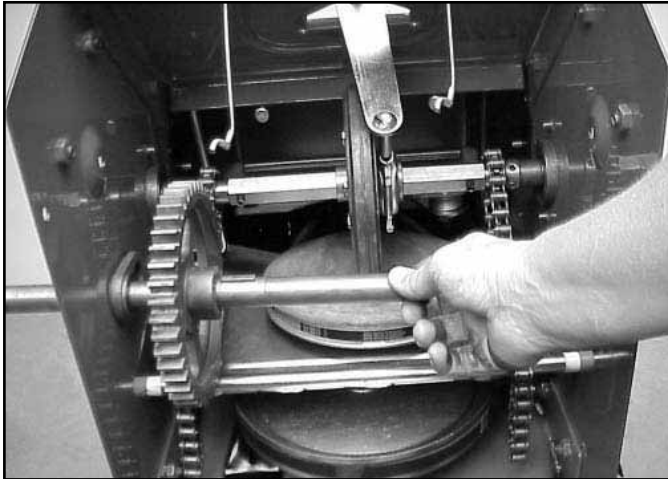

Fig 130 MVC-860XYZ.jpg

15. Remove the two screws from the shift rod bracket and remove the traction control lever and bracket assembly from the friction wheel (Fig. 131 and 132).

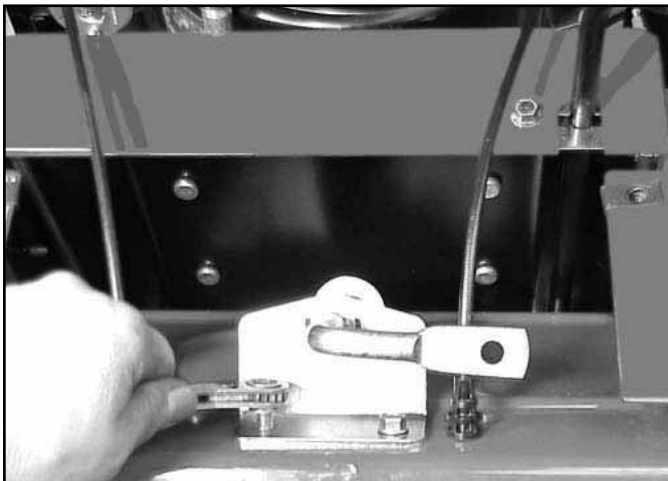

Fig 131 MVC-859X.jpg

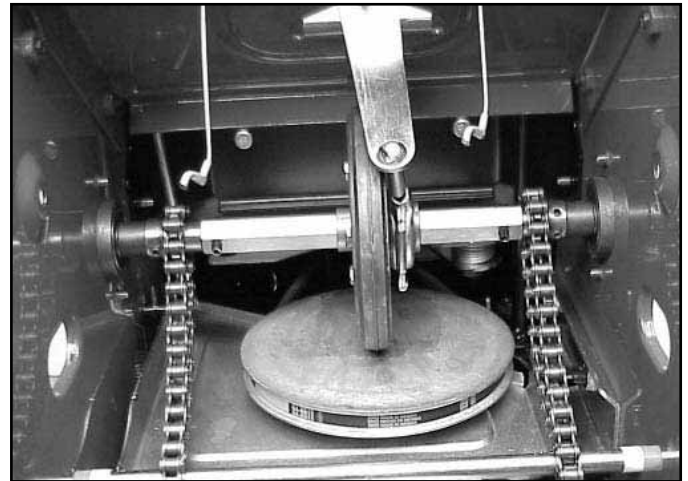

Fig 132 MVC-860X.jpg

16. If not already done, remove the bearing retainer that holds the hex shaft (Fig. 133).

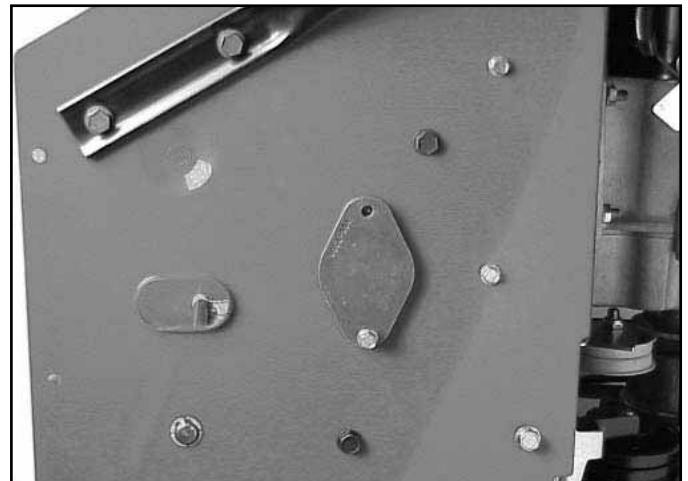

Fig 133 MVC-864XYZ.jpg

WHEEL CLUTCH TRACTION DRIVE SYSTEM

17. Remove hex shaft clutch assembly / friction wheel from housing (Fig. 134).

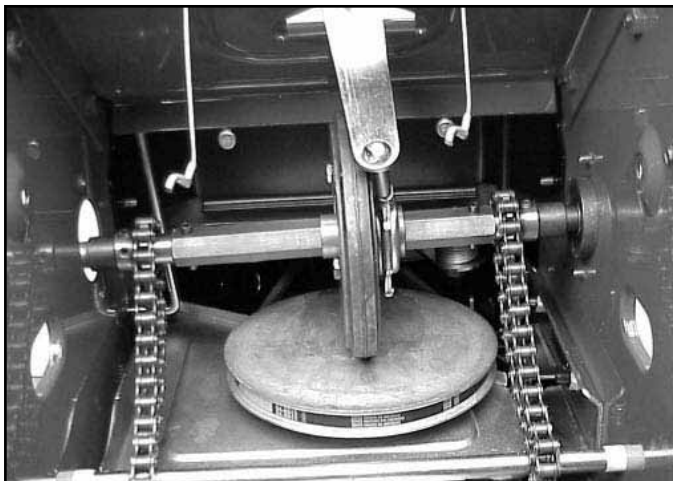

Fig 134

MVC-867X.jpg

19. Move snowthrower to the upright position and remove belt cover (Fig. 136).



Fig 136

MVC-861XB.jpg

18. Remove friction wheel from hex shaft by removing the 3 nuts and bolts that hold the friction wheel to the plate on the hex shaft (Fig. 135).

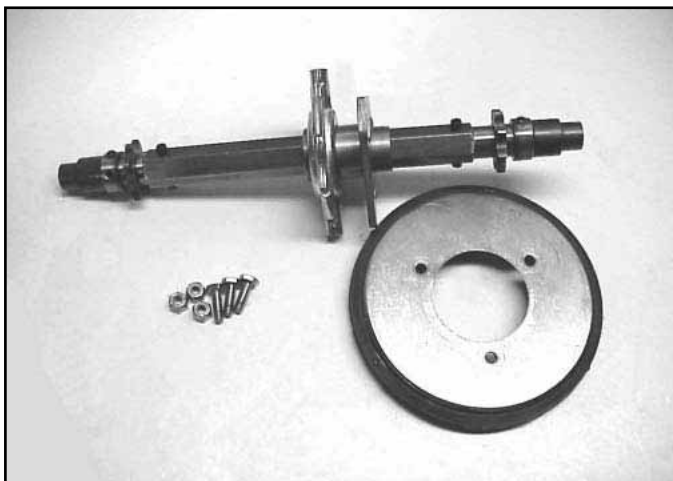

Fig 135

MVC-858X2.jpg

20. Remove extension cover (Fig. 137).

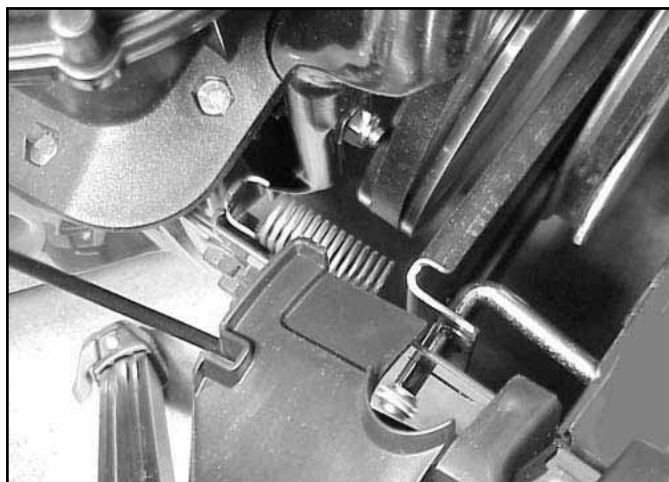

Fig 137

MVC-862X.jpg

WHEEL CLUTCH TRACTION DRIVE SYSTEM

21. Remove hairpin cotter connecting speed control linkage to the pivot pulley plate assembly (Fig. 138).

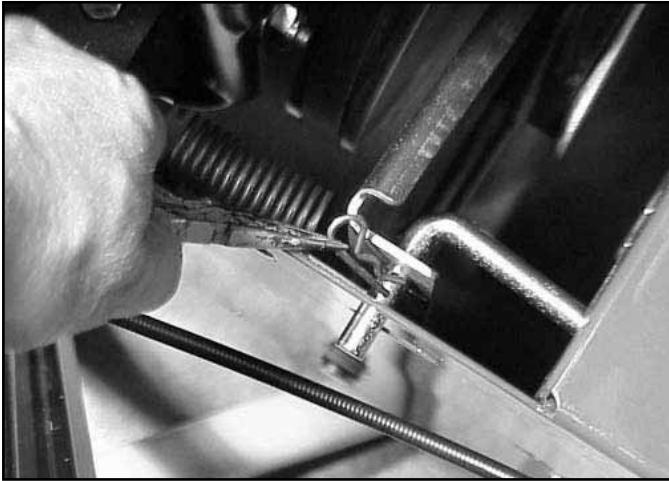

Fig 138

MVC-863XB.jpg

23. Slide speed control linkage from pivot pulley plate assembly (Fig. 140).

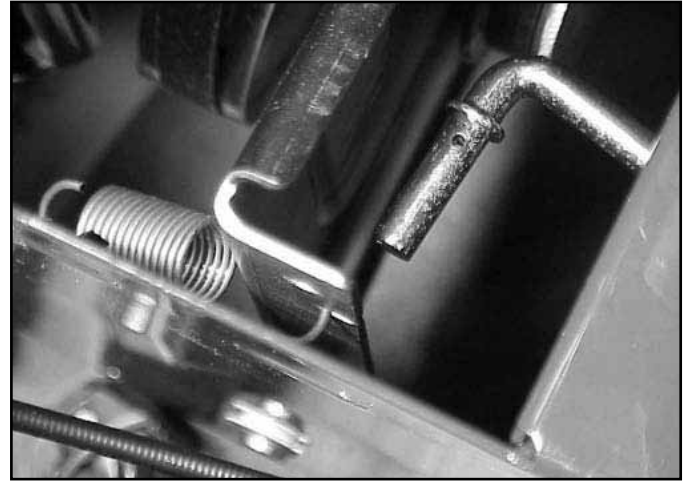

Fig 140

MVC-865XB.jpg

22. Remove extension spring from housing (Fig. 139).

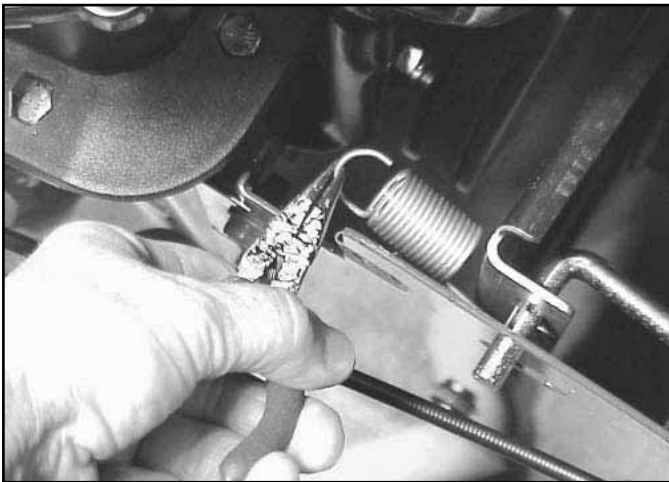

Fig 139

MVC-864X.jpg

24. Turn the snowthrower back onto the auger housing.

WHEEL CLUTCH TRACTION DRIVE SYSTEM

25. Remove retaining ring from both sides of housing (Fig. 141) and slide the nyliner bushing off the pivot pulley plate shaft (Fig. 142).



Fig 141

MVC-866XB.jpg

26. Tilt pivot pulley assembly to release the traction belt tension and remove belt from traction pulley (Fig. 143).



Fig 143

MVC-868X.jpg

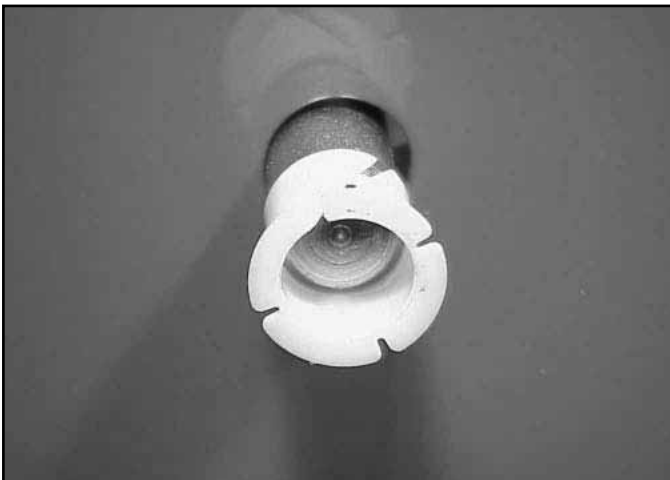

Fig 142

MVC-866Xny.jpg

27. Remove the pivot pulley plate assembly from the housing (Fig. 144).

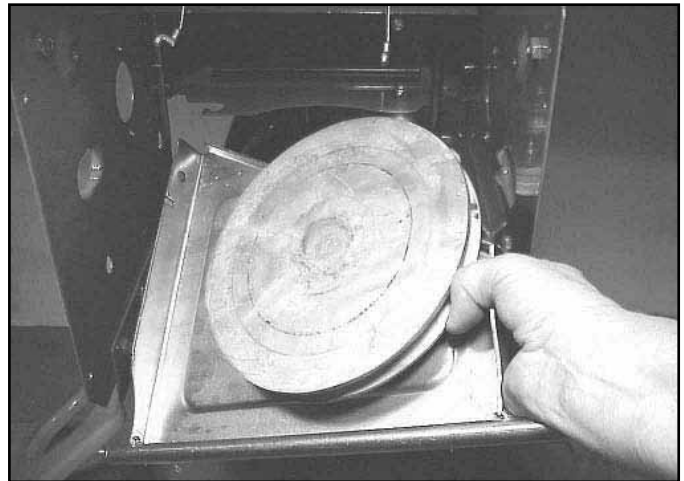

Fig 144

MVC-869X.jpg

WHEEL CLUTCH TRACTION DRIVE SYSTEM

28. Remove the locknut from pivot pulley and separate pulley from pivot plate (Fig. 145 and Fig. 146).

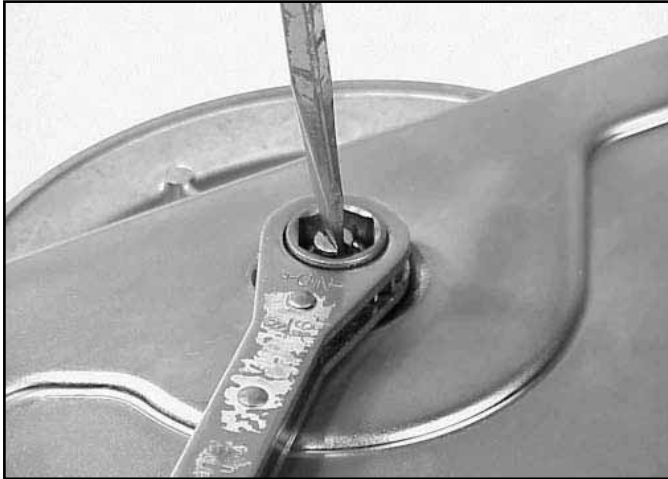

Fig 145

MVC-870XB.jpg

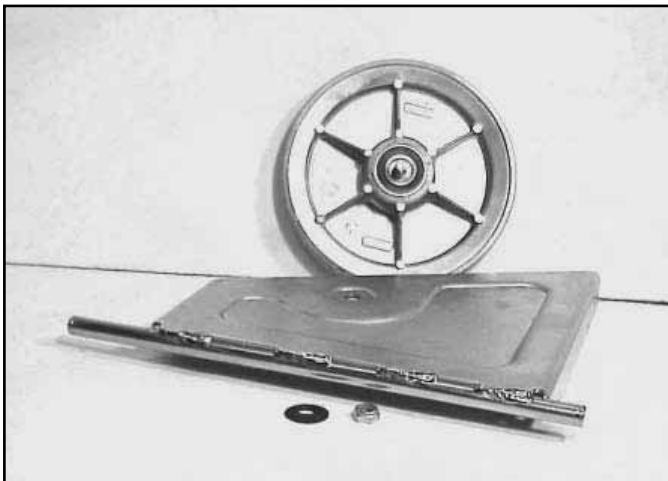

Fig 146

MVC-010X.jpg

DRIVE SYSTEM REASSEMBLY

1. Install pivot plate assembly into the housing and install belt. The idler pulley should be pushed away from you to install the pivot plate (Fig. 147).

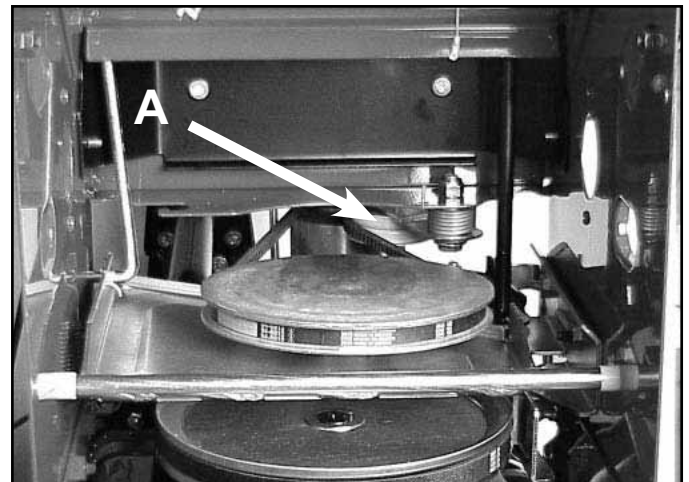

Fig 147

MVC-036X.jpg

A. Idler Pulley

2. Install the two bushings and the two "C" clips onto the pivot plate shaft (Fig. 148).



Fig 148

MVC-037X.jpg

WHEEL CLUTCH TRACTION DRIVE SYSTEM

3. Install the speed control linkage through the pivot plate and install the hair clip into the hole of the speed control linkage on the outside of the pivot plate (Fig. 149).

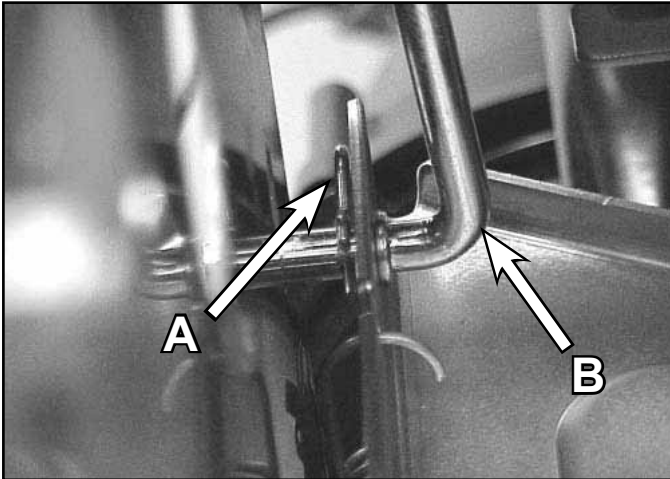

Fig 149 MVC-039X.jpg

A. Hairpin Cotter B. Speed Control Link

4. Install long end of spring to cut out on the pivot plate (Fig. 150) and the short end of the spring to the frame (Fig. 151).

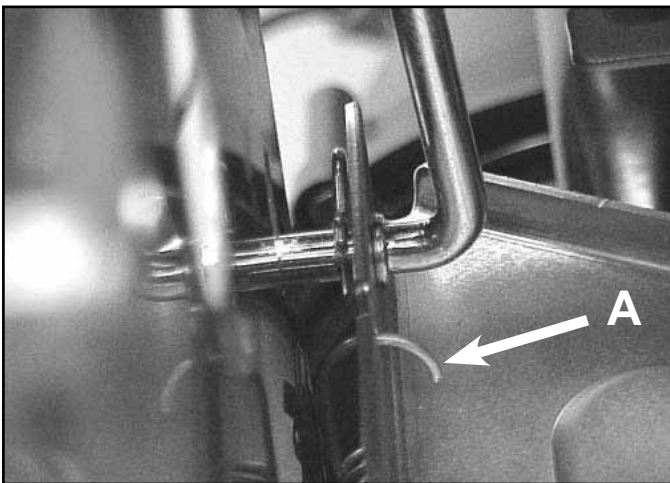

Fig 150 MVC-039X.jpg

A. Spring

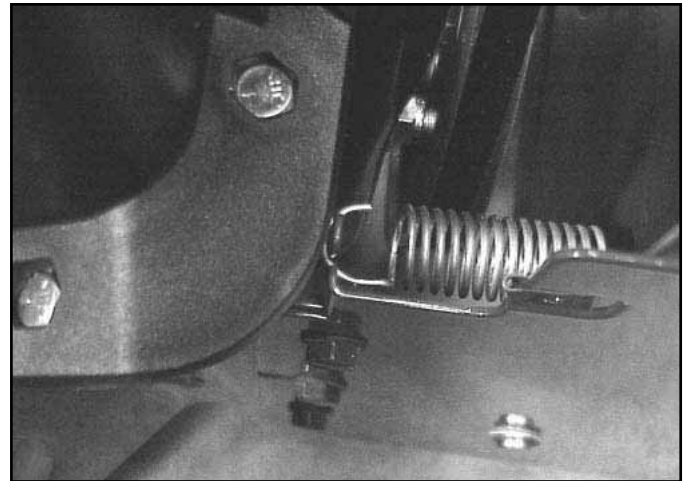

Fig 151 MVC-041X.jpg

5. Install friction wheel assembly. You can lay the shift mechanism onto the housing and insert shift shaft into friction wheel assembly in the direction shown. It is important that the friction wheel and shift mechanism are to the right of the snowthrower (Fig. 152).

Note: Make sure the wheel is free of dirt, oil, anti-seize or any other lubricant.

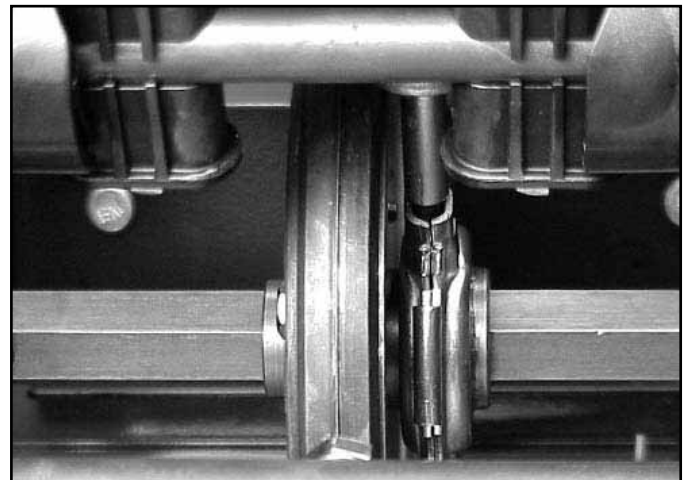

Fig 152 MVC-031XYX.jpg

WHEEL CLUTCH TRACTION DRIVE SYSTEM

6. Before mounting the friction wheel assembly, install the chains onto the 8-tooth sprockets making sure the closed end of the master link is going in the direction of rotation in the forward gears (Fig. 153 and 154).

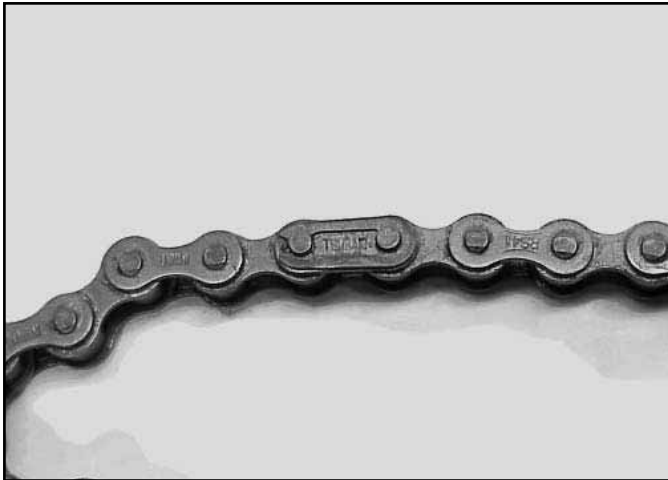

Fig 153

MVC-051X.jpg

7. Install both bearing retainers (if both were removed) (Fig. 155).

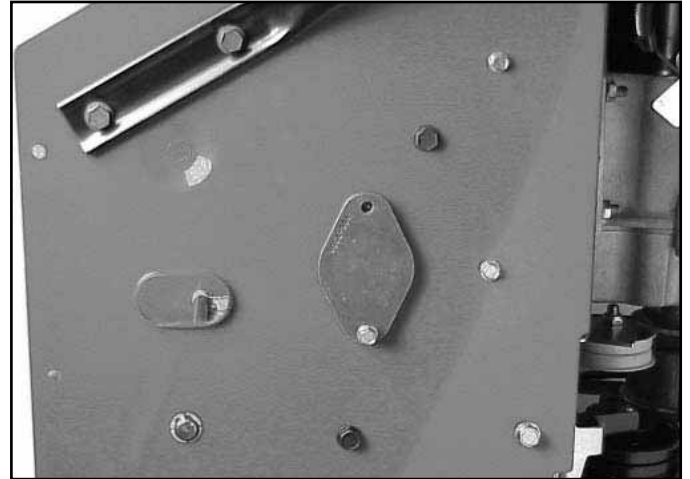

Fig 155

MVC-864XYZ.jpg

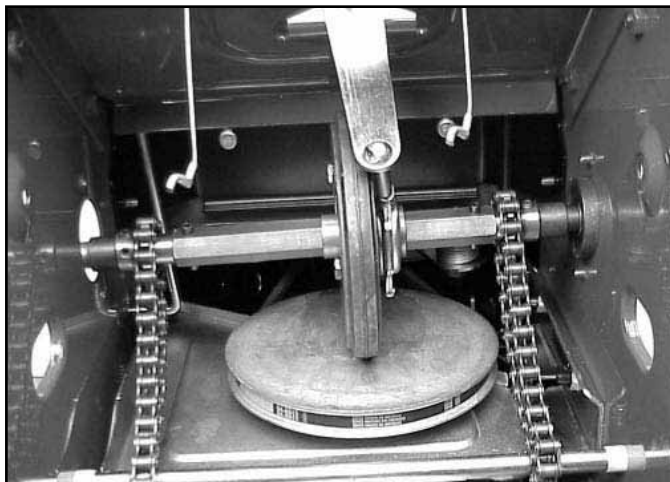

Fig 154

MVC-867X.jpg

8. Before installing the axle with the 44-tooth sprockets apply a light coat of anti-seize to the outer 5 inches of both ends of the axle shaft. Also apply a light coat to the inside diameter at both ends of the tube about 4 inches (Fig. 156).

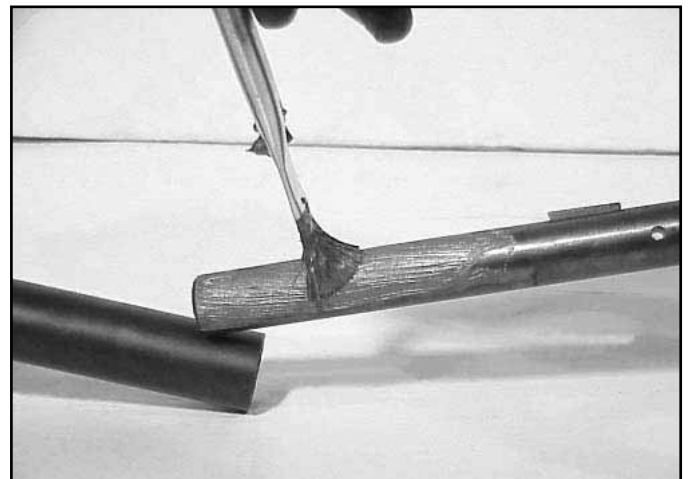

Fig 156

MVC-046X.jpg

WHEEL CLUTCH TRACTION DRIVE SYSTEM

9. Make sure the axle bearing end that is holding the axle shaft is on the bottom (Fig. 157).

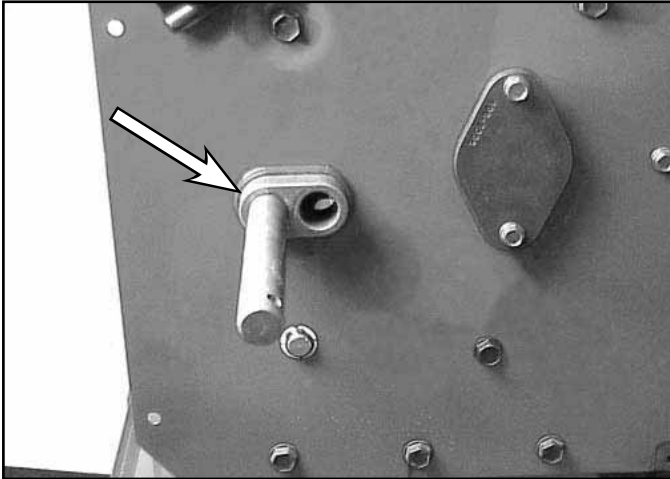

Fig 157

MVC-857X.jpg

11. Slide one end of the axle shaft with tube into the housing (Fig. 159).

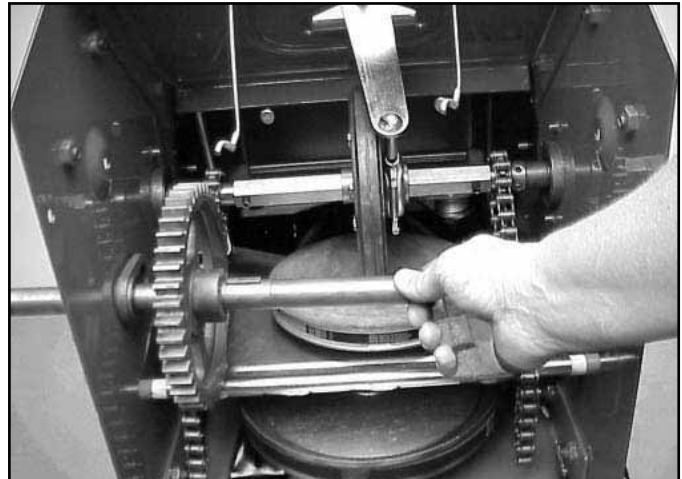

Fig 159

MVC-052X.jpg

10. 44-tooth gears should have hub facing inward (Fig. 158).

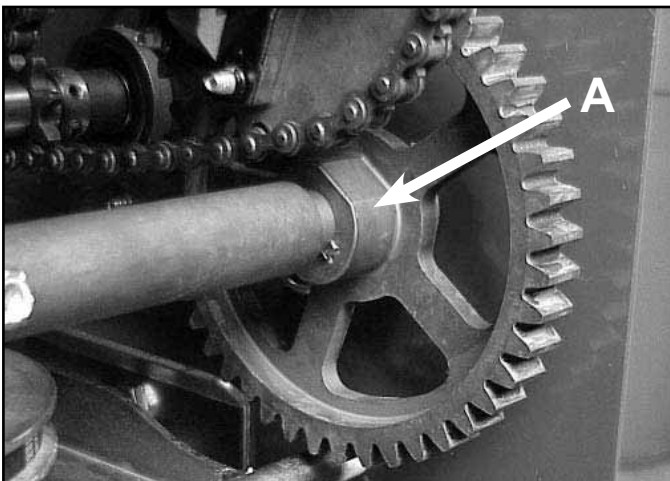

Fig 158

MVC-871XYZ.jpg

A. Hub

12. With the woodruff key out of the other side of the shaft as well as all the other components, install axle bearing onto housing and then slide the shaft in through the bearing and housing, through the two washers and 44-tooth gear sprocket into the tube (Fig. 160).

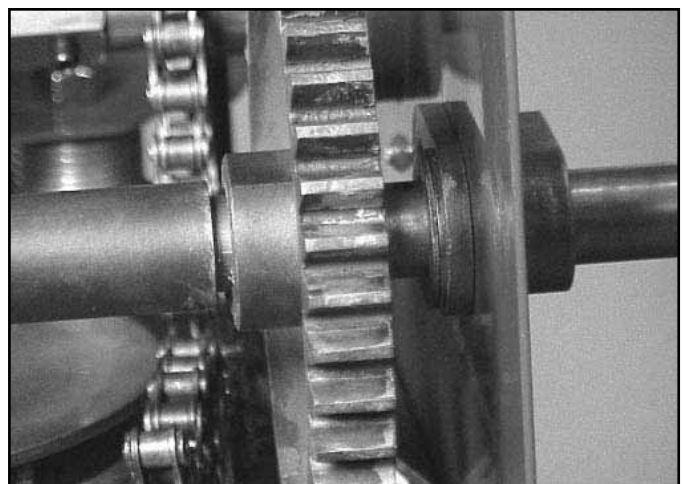

Fig 160

MVC-056X.jpg

WHEEL CLUTCH TRACTION DRIVE SYSTEM

13. Insert the woodruff key onto the axle shaft evenly and make sure the 44-tooth gear can ride over the shaft freely (Fig. 161).

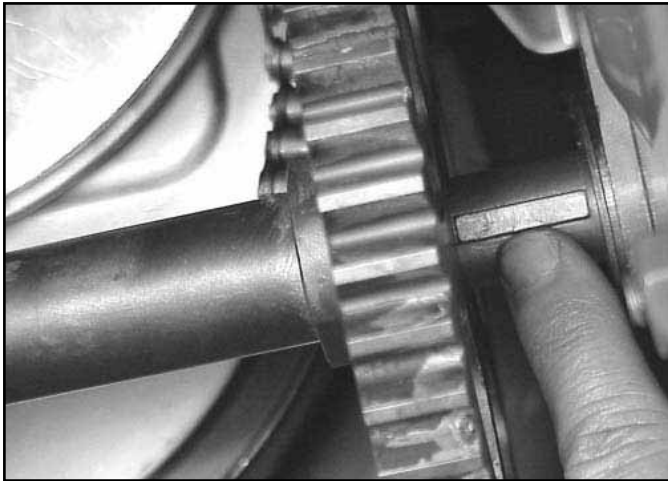

Fig 161

MVC-059X.jpg

15. Lightly coat the 44-tooth sprocket with anti-seize (Fig. 163).

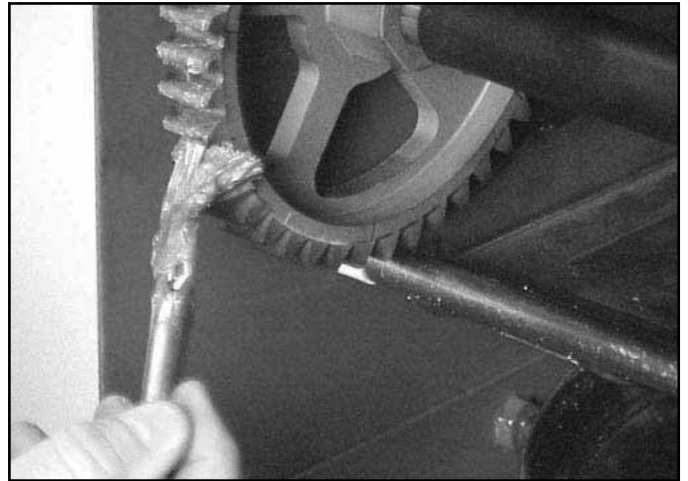

Fig 163

MVC-2205X.jpg

14. Position the hole for the hairpin cotter between the 2 washers and push the hairpin cotter into place (Fig. 162). Repeat for the other side.

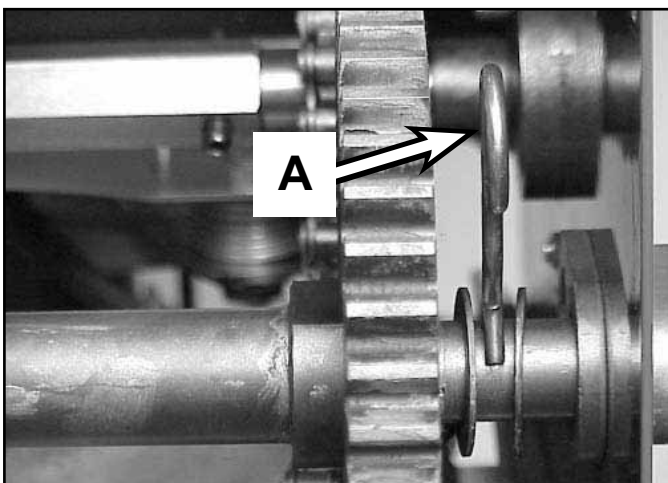

Fig 162

MVC-061X.jpg

A. Hairpin Cotter

16. Before installing the wheel clutch assembly, lightly coat the 11-tooth gear of the wheel clutch with anti-seize (Fig. 164).

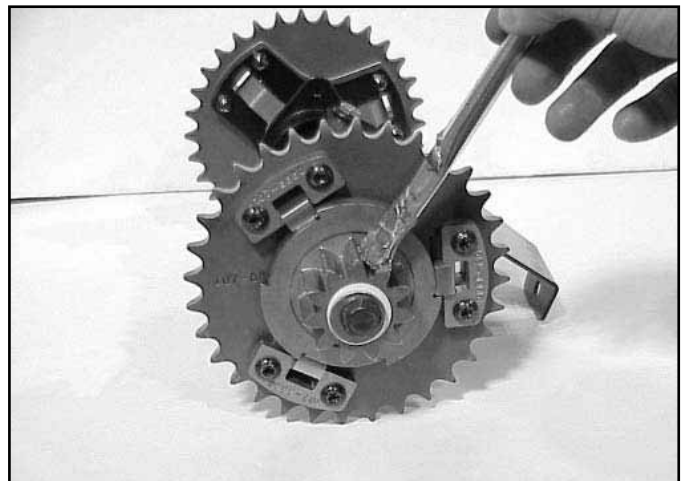

Fig 164

MVC-035X.jpg

WHEEL CLUTCH TRACTION DRIVE SYSTEM

17. Install wheel clutch assembly with the brace shift plate facing away and up towards housing making sure collars are correctly installed with the "RIGHT" and "LEFT" facing inward and the right and left flanges are facing you (Fig. 165).

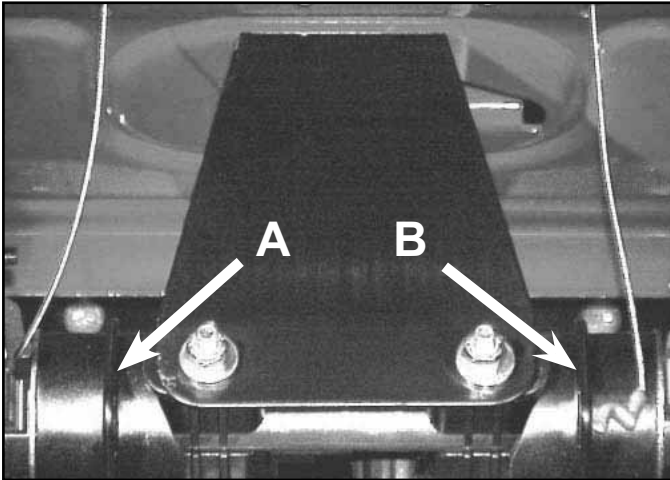

Fig 165 MVC-2200X.jpg

A. Left Collar B. Right Collar

18. Route the chains around the 32-tooth gear of the clutch assembly (Fig. 166).

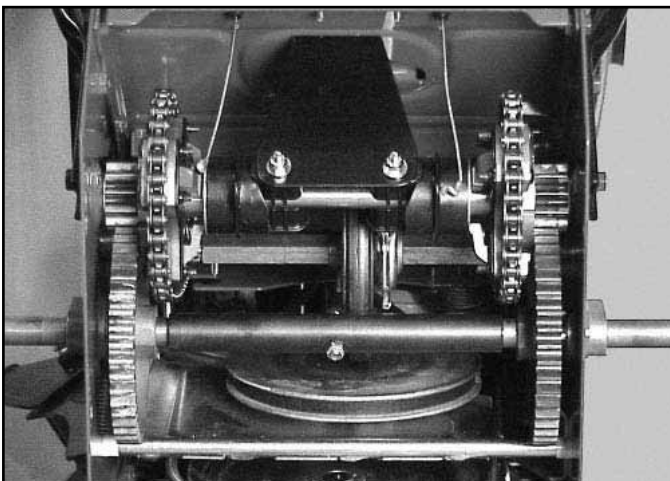

Fig 166 MVC-2207X.jpg

19. Attach the shift brace plate to the housing (Fig. 167).

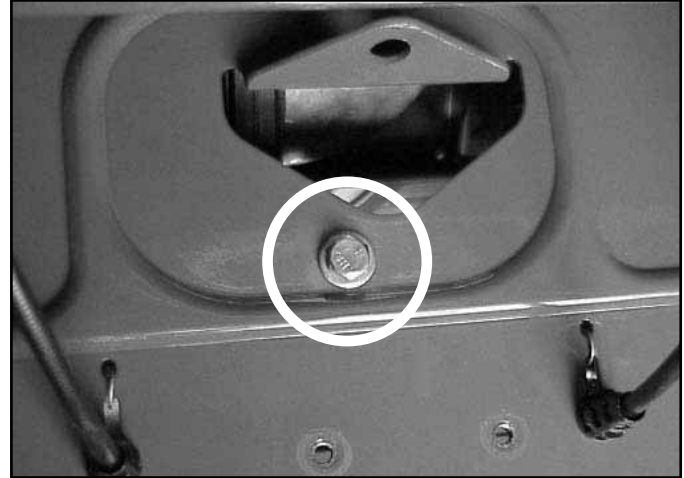

Fig 167 MVC-894XYX.jpg

20. Torque the two intermediate shaft screws to 170 to 300 in-lbs. (19.2 to 33.9 Nm) (Fig. 168).



Fig 168 MVC-8562X.jpg

WHEEL CLUTCH TRACTION DRIVE SYSTEM

21. Install the 2 extension springs from the lower part of the shift collar flange (Fig. 169) to the housing (Fig. 170).

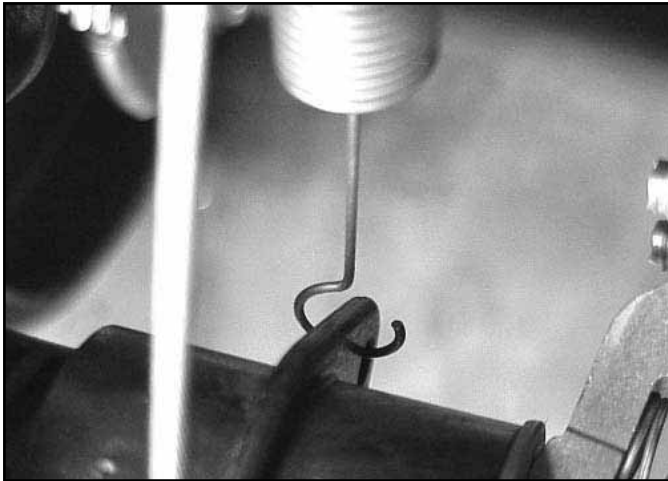

Fig 169

MVC-032XZV.jpg

22. Install Z bend of the clutch cable from outside to inside of the shift collar (Fig. 171).

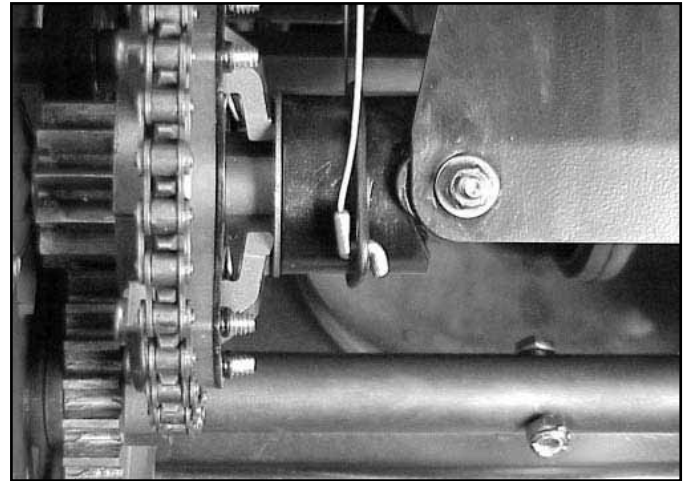

Fig 171

MVC-876XYZ.jpg

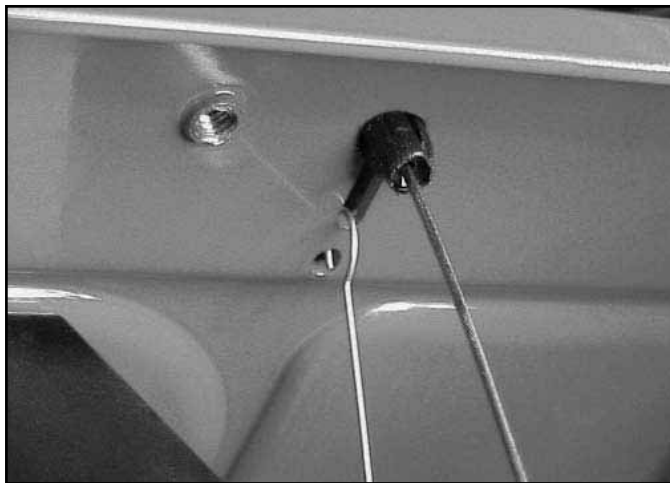

Fig 170

MVC-899XB.jpg

23. Install shift rod / traction rod lever onto the housing (Fig. 172) making sure the traction control fits into the friction wheel (Fig. 173).

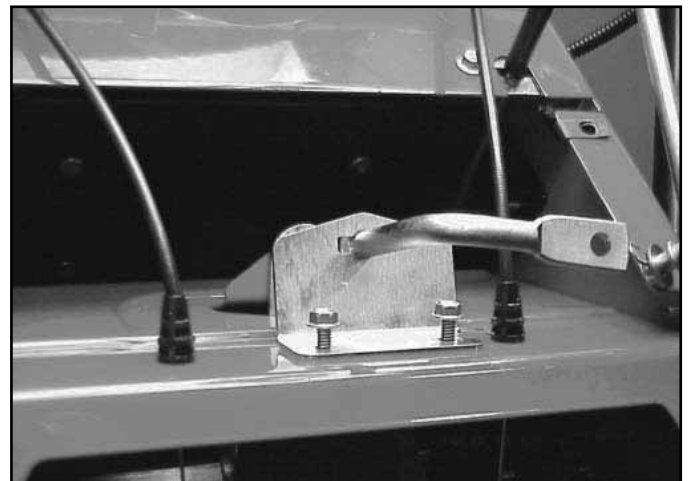

Fig 172

MVC-859X2.jpg

WHEEL CLUTCH TRACTION DRIVE SYSTEM

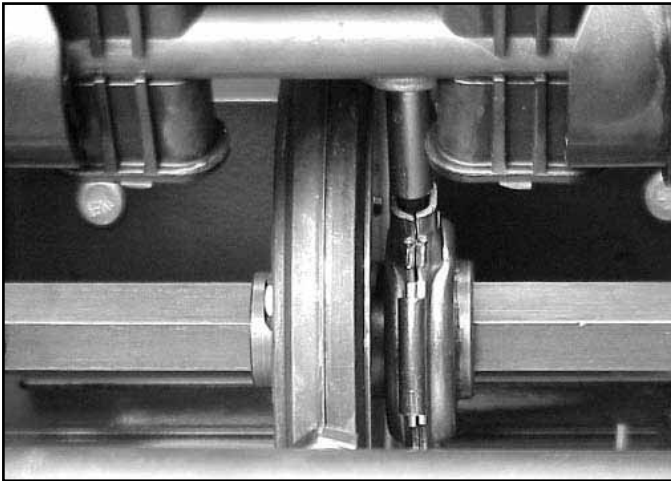

Fig 173 MVC-031XYX.jpg

25. Install the upper and lower covers, with the upper cover over lapping the lower cover (Fig. 175).

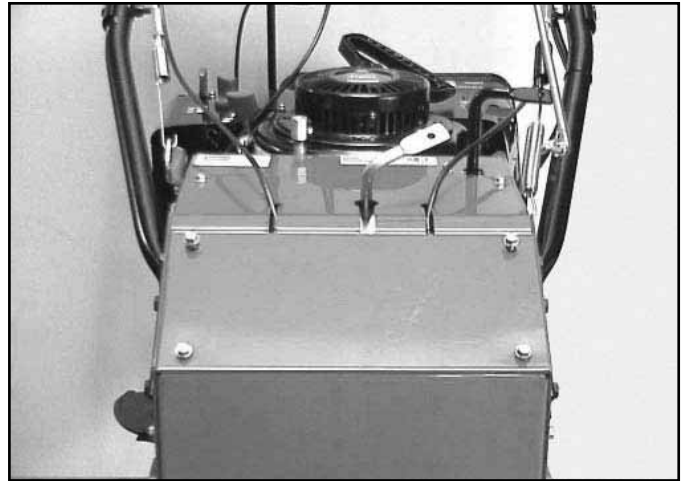

Fig 175 MVC-2193X.jpg

24. Install the lower cover (Fig. 174).

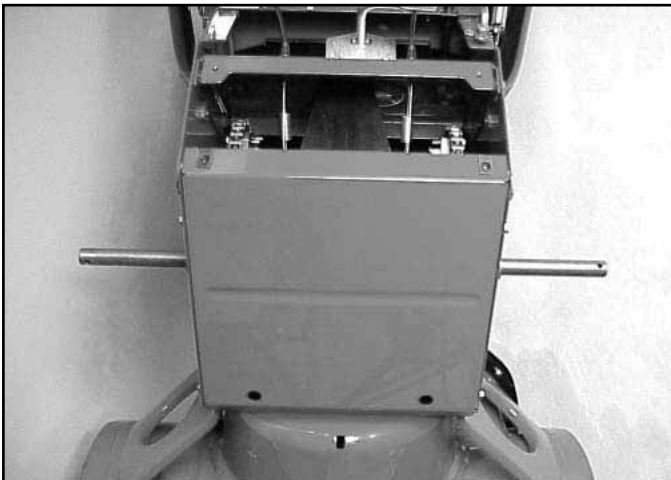

Fig 174 MVC-872XYX.jpg

26. Connect the shift linkage to the shift rod / traction rod lever (Fig. 176).

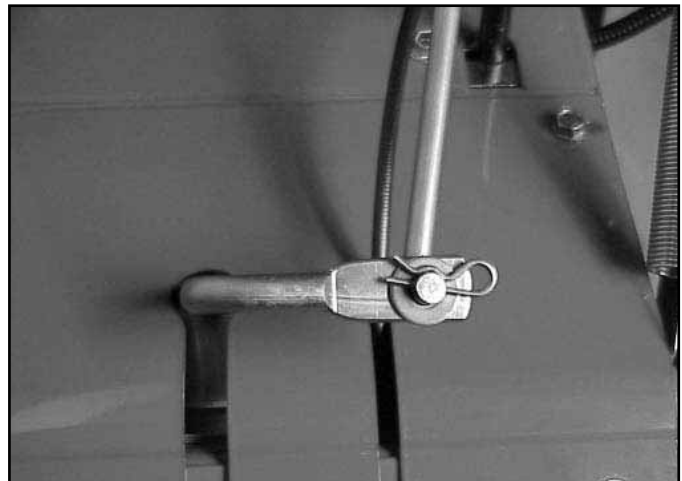

Fig 176 MVC-874XYX.jpg

WHEEL CLUTCH TRACTION DRIVE SYSTEM

27. Wheels are installed with the “V” tread rotation forward (Fig. 177).



Fig 177

MVC-880X1.jpg

28. Bolt wheel hub to axle shaft and torque to 115 ± 15 in-lbs. (12.99 ± 1.7 Nm) (Fig. 178).



Fig 178

MVC-884XT.jpg

29. Install the belt extension cover and belt cover.
30. Check clutch cable adjustment and adjust if necessary. See Adjustments

WHEEL CLUTCH DISASSEMBLY

1. Remove 11-tooth gear from 32-tooth gear by sliding it from the shaft (Fig. 179).



Fig 179

MVC-876XB.jpg

2. Slide off washer behind the 11-tooth gear (Fig. 180).

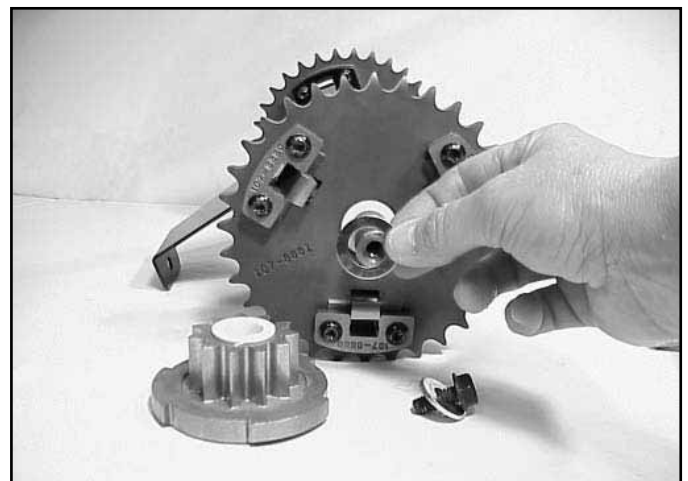

Fig 180

MVC-877X.jpg

WHEEL CLUTCH TRACTION DRIVE SYSTEM

3. Remove 32-tooth sprocket gear and the thrust washer from the shaft (Fig. 181).



Fig 181 MVC-878XB.jpg

5. Unbolt the 4 guide collars from the shaft (Fig. 183).



Fig 183 MVC-881X.jpg

4. Remove shift collar and flat washer from the shaft (Fig. 182).

Note: Shift collars are marked right and left hand at the top of the inside flange (A).

Note: This hole, for the spring, has been changed to a "D" shape during 2004 for ease in identifying the correct hole (B).

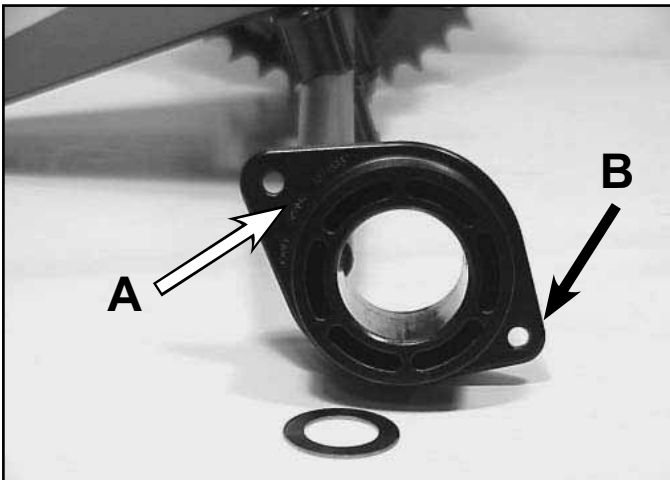

Fig 182 MVC-879X.jpg

6. Remove the wheel clutch components from the other end of the shaft (Fig. 184).



Fig 184 MVC-883XWC.jpg

WHEEL CLUTCH TRACTION DRIVE SYSTEM

7. Remove the 3 (per gear) compression springs from under the pawls and set aside (Fig. 185).

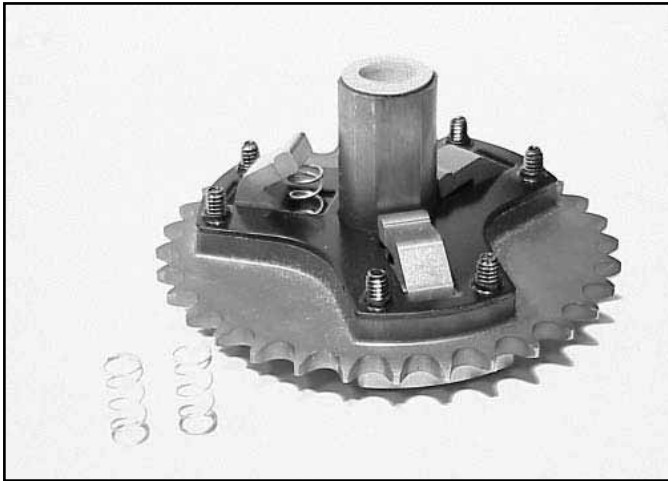

Fig 185

MVC-884XB.jpg

9. Remove the retainer plate off of the gear hub (Fig. 187).

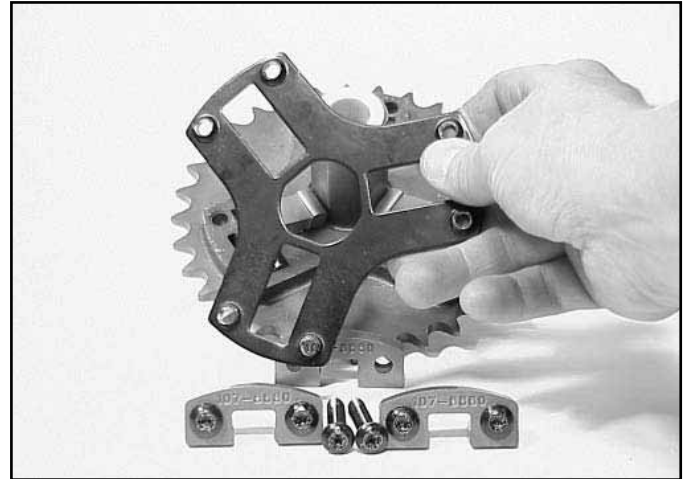

Fig 187

MVC-888XWC.jpg

8. Remove 6 (per side) T-27 torx screws that hold the pawl supports (Fig. 186).



Fig 186

MVC-886X.jpg

WHEEL CLUTCH TRACTION DRIVE SYSTEM

10. Remove pawl pins and pawls with from the 32-tooth gear (Fig. 188 and Fig. 189).

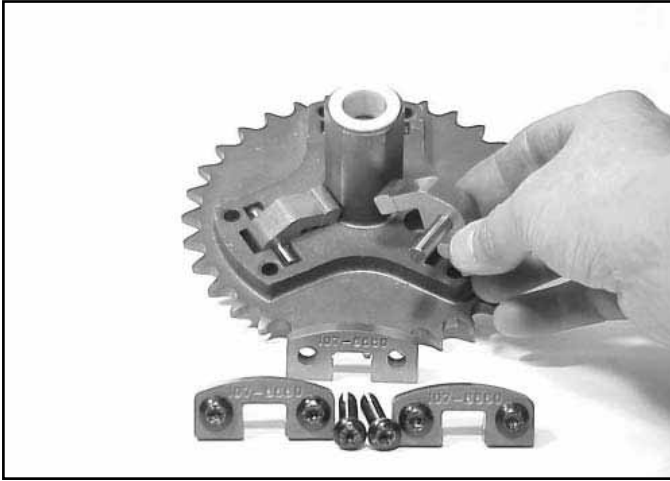

Fig 188

MVC-889XWC.jpg

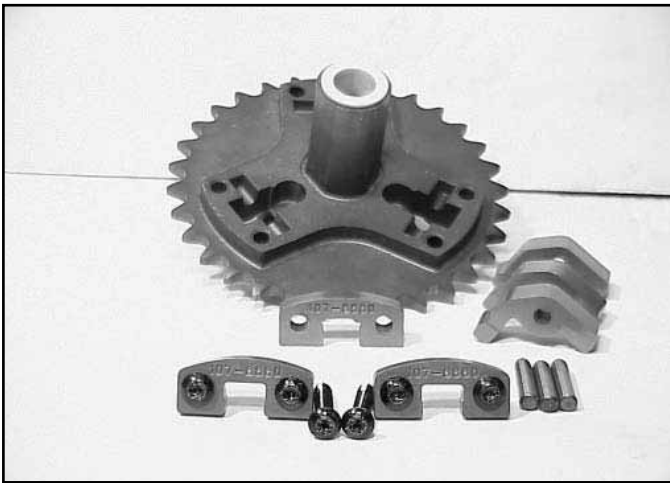

Fig 189

MVC-890XB.jpg

11. Repair or replace defective components.

WHEEL CLUTCH REASSEMBLY

Note: Apply a light coat of SAE 30W oil to intermediate shaft before assembly.

1. Set the 32-tooth gear on a flat surface and install pawls. Apply a light coat of oil Toro part no. 505-5 to dowel pins then install dowel pins into the pawl assembly (Fig. 190).

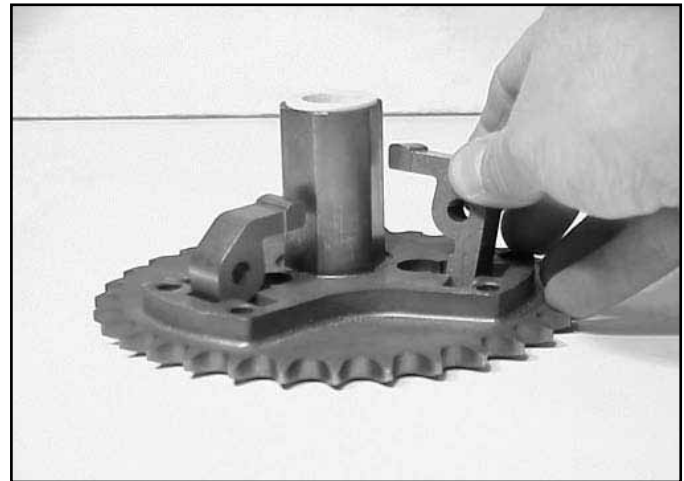

Fig 190

MVC-902XWC.jpg

2. With the pawls facing up and away from the hub, slide the retainer plate onto hub. Make sure the pins are seated flush and the retainer plate sits flush onto the gear (Fig. 191).

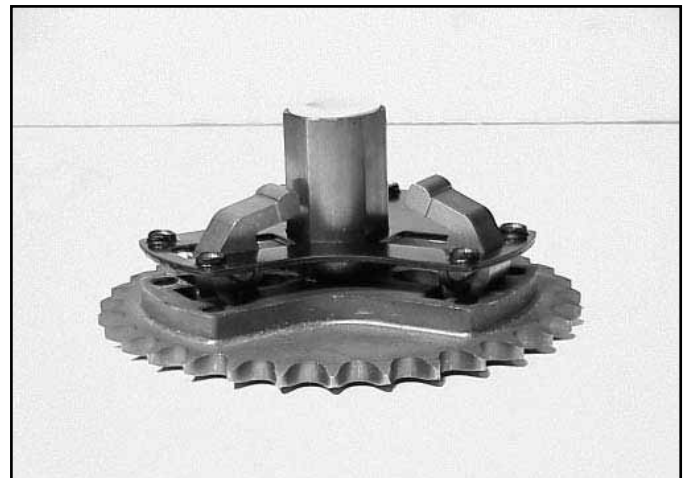

Fig 191

MVC-901XWC.jpg

WHEEL CLUTCH TRACTION DRIVE SYSTEM

3. Clamp or hold gear and turn it over to properly install the 3 pawl supports and torx screws (Fig. 192).



Fig 192

MVC-904X.jpg

5. Install the 4 guide collars to shaft with shift brace plate (Fig. 194).

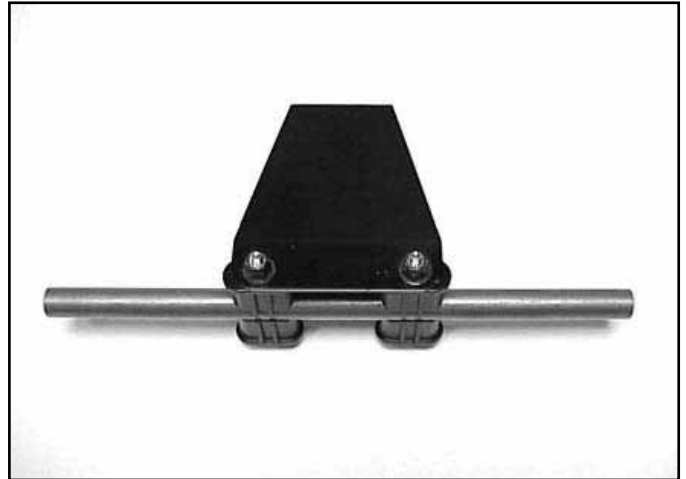

Fig 194

MVC-1909X.jpg

4. Torque the T-27 torx screws to 100 to 125 in-lbs. (11.3 to 14.1 Nm) (Fig. 193).

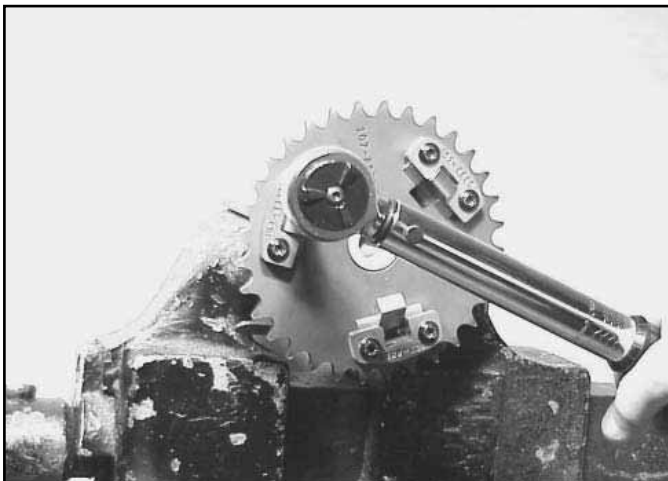

Fig 193

MVC-905XWC.jpg

6. Torque the screws no more than 50 - 70 in-lbs. (5.65 - 7.9 Nm).

7. Slide flat washers next to guides (Fig. 195).

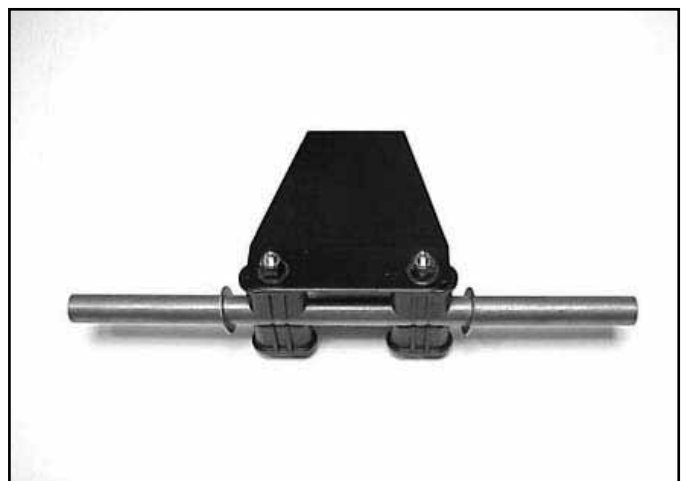

Fig 195

MVC-1911X.jpg

WHEEL CLUTCH TRACTION DRIVE SYSTEM

8. Install RIGHT and LEFT collar.

Note: The top flanges of the shift collars have “left” and “right” stamped into them (Fig. 196). Install accordingly on the right and left ends of the shaft with the shift brace plate oriented as shown (Fig. 197).



Fig 196

MVC-880X.jpg

9. Install compression springs under the pawls (Fig. 198).

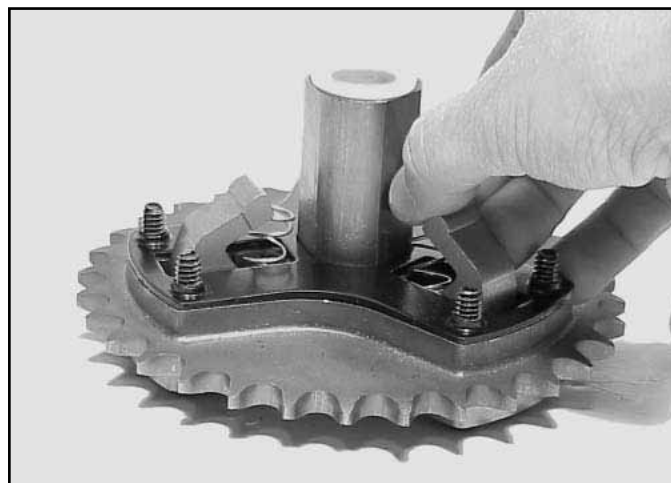

Fig 198

MVC-001XB.jpg

10. Slide thrust washer onto the 32-tooth sprocket gear (Fig. 199).

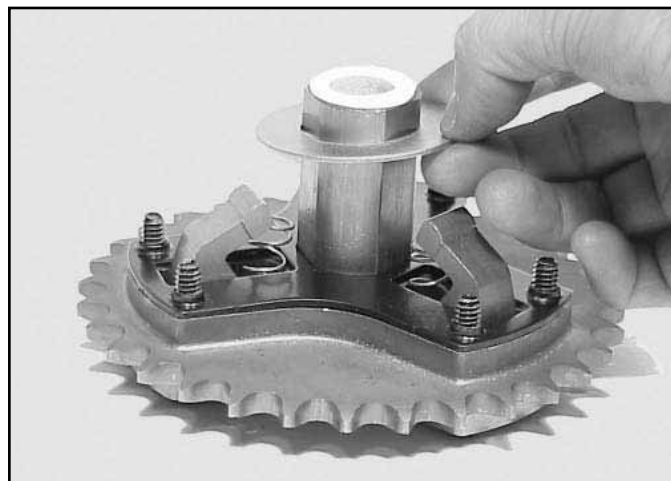

Fig 199

MVC-002X.jpg

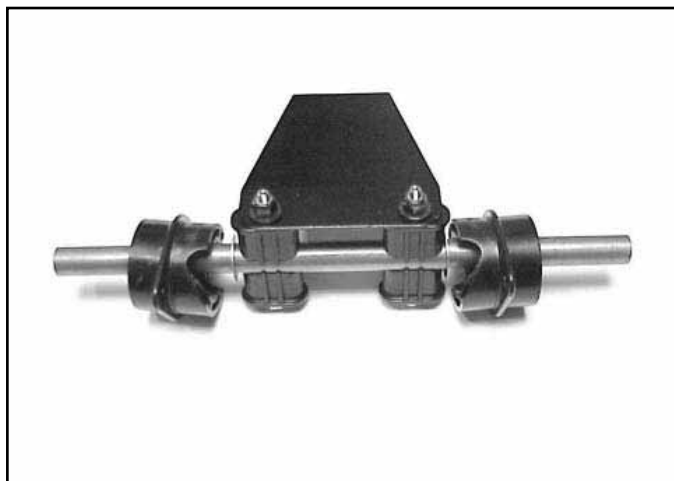

Fig 197

MVC-1915X.jpg

WHEEL CLUTCH TRACTION DRIVE SYSTEM

11. Slide the complete 32-tooth gear sprocket onto the shaft (Fig. 200).

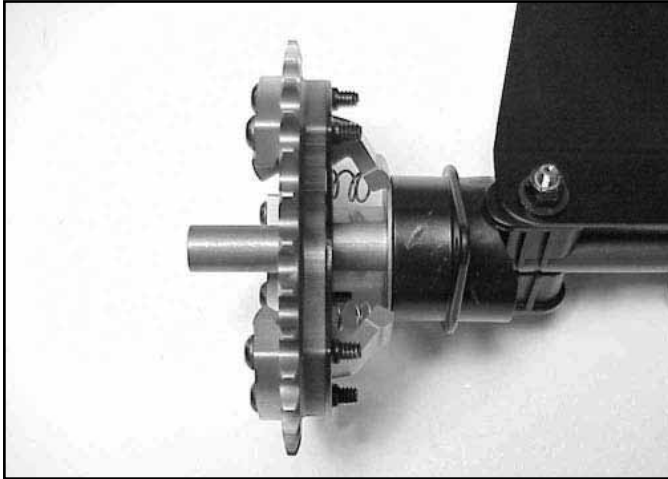

Fig 200

MVC-1180X.jpg

13. Make sure 11-tooth gear slides on so it is flush with the end of the shaft (Fig. 202).

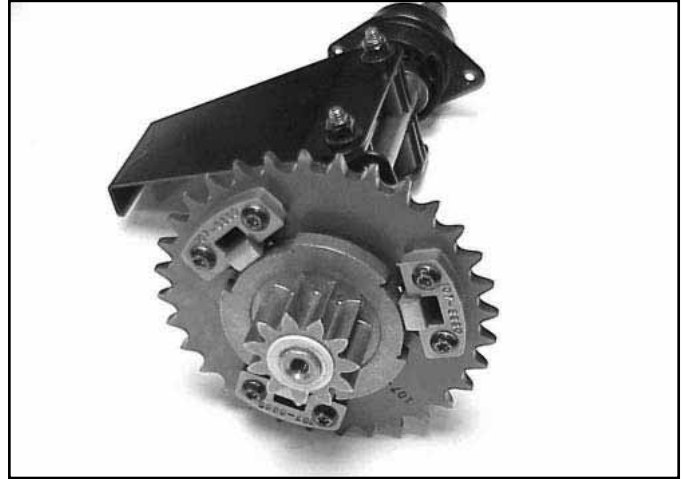

Fig 202

MVC-1184X.jpg

12. Install flat washer (Fig. 201).

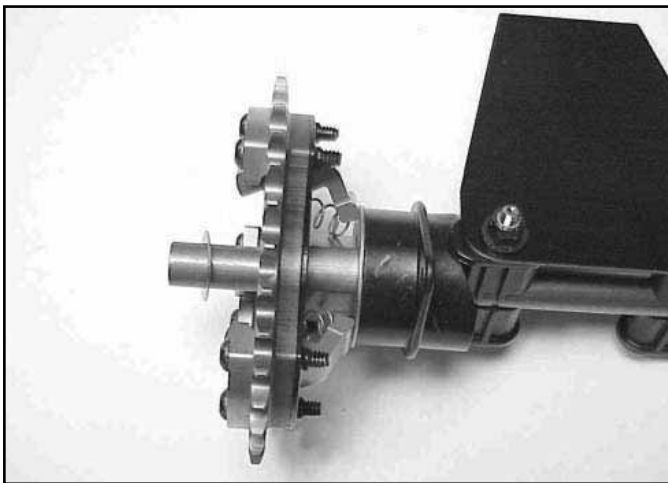

Fig 201

MVC-1177X.jpg

14. Make sure the pawls are up against the thrust washer and the springs are not binding and are compressing properly (Fig. 203).

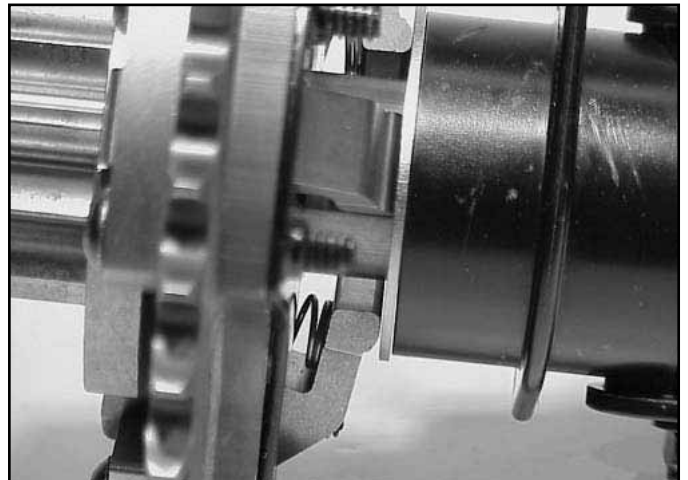

Fig 203

MVC-006X.jpg

WHEEL CLUTCH TRACTION DRIVE SYSTEM

15. Apply a light coat of anti seize to the 11-tooth gear (Fig. 204). Repeat the process for the opposite side.

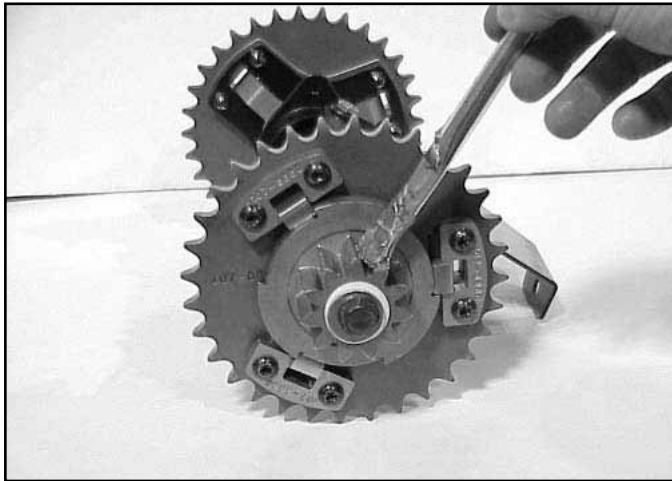

Fig 204

MVC-035X.jpg

Refer to the drive system reassembly procedure, beginning with step 17 on page 9-14.

After installation into the housing, rotate left and right collars fully to the stop. Ensure that the mechanism operates smoothly. Check each of the 6 pawls to ensure that it returns fully when the shift collar is released. (A non-returning pawl indicates binding or missing parts).

16. Assembly can now go back into housing (Fig. 205).

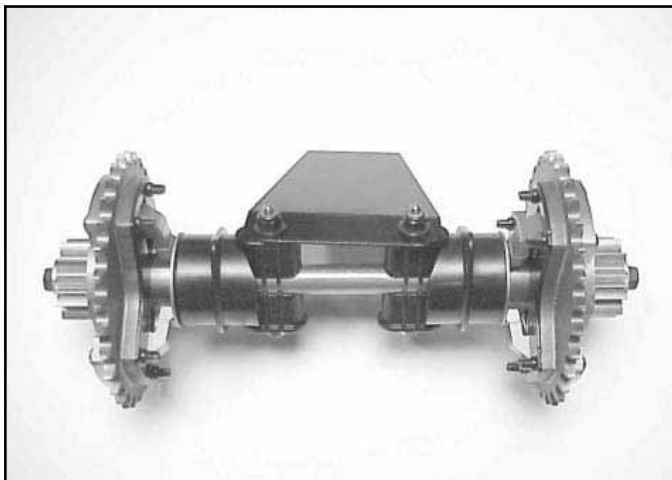

Fig 205

MVC-1905X.jpg

DISCHARGE CHUTE

CHUTE AND AUGER COVER REMOVAL

1. Disconnect the deflector cable from the deflector (Fig. 206).

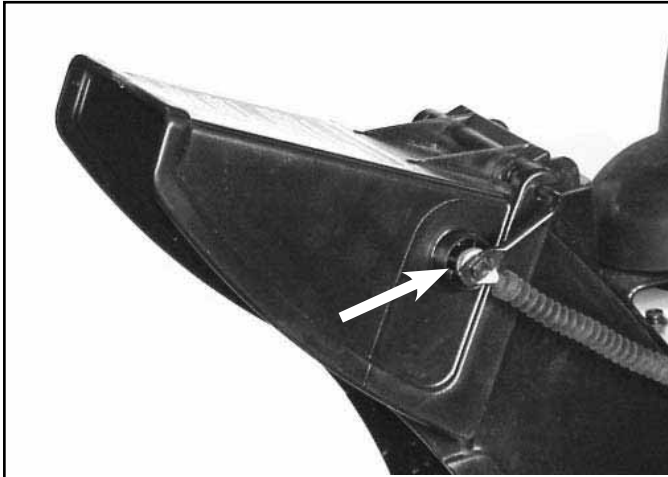

Fig 206

MVC-3878X

2. Remove the single screw retaining the gear cover, lift the front of the cover, and slide it to the rear (Fig. 207).

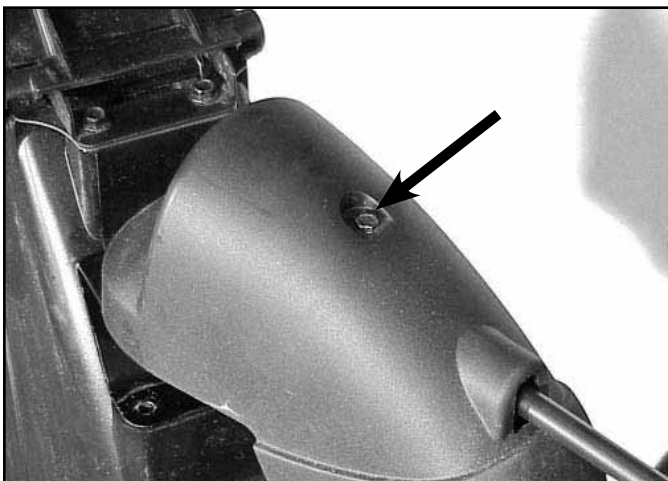

Fig 207

MVC-883X

3. Remove the single screw between the gear and the chute (Fig. 208).

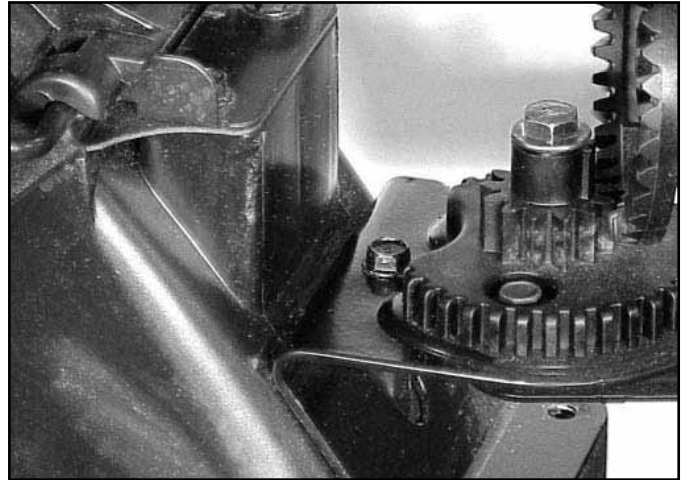

Fig 208

MVC-884X

4. Remove two screws that secure the cable clamp bracket and the chute support bracket to the chute (Fig. 209). Leave the cable clamped to the bracket unless the cable is to be replaced and set aside.

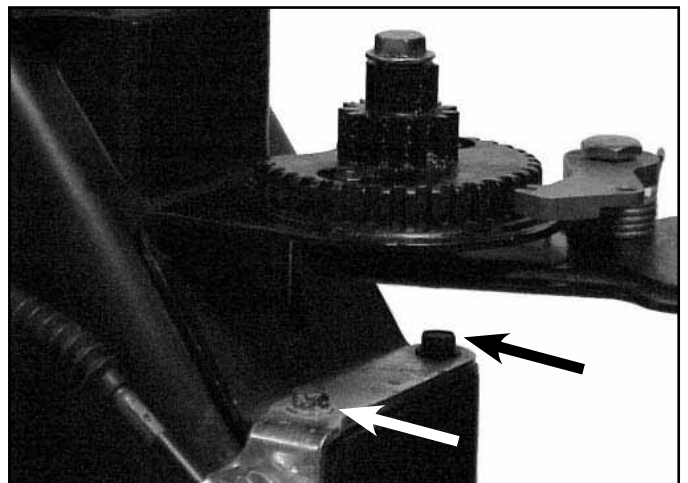

Fig 209

MVC-824X

DISCHARGE CHUTE

5. Lift the chute and deflector off of the auger cover (Fig. 210).



Fig 210

MVC-885X

7. If necessary the deflector can be separated from the chute by removing the hinge (Fig. 212).



Fig 212

MVC-807X

6. There is a ring on the base of the chute that is secured with three screws (Fig. 211).



Fig 211

MVC-804X

8. The last chute component is the chute guide. It is attached to the auger cover with one screw in front and tabs on the rear (Fig. 213).

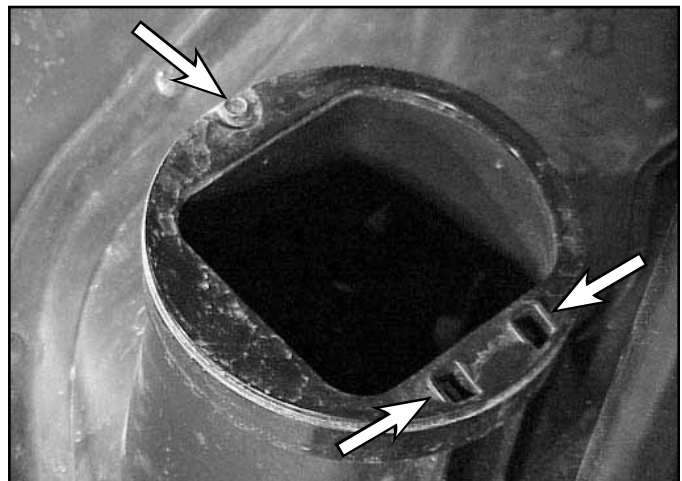

Fig 213

MVC-891X

DISCHARGE CHUTE

If the auger cover is to be removed the first step is to remove both of the belt covers (Fig. 214).



Fig 214

MVC-893XA

The auger cover is attached to the auger housing with carriage bolts and locknuts (Fig. 215).

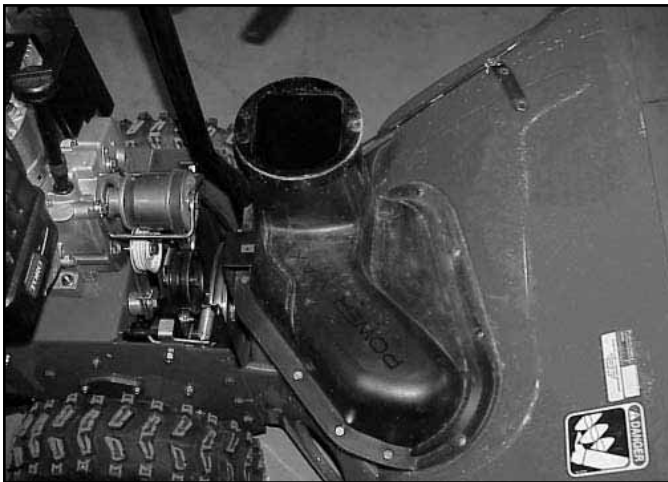

Fig 215

MVC-898XA

Assemble in reverse order. The metal seal is installed under the mounting flange on the left rear corner of the auger housing. (Fig. 216).

Note: Do not over-tighten to the point the cover starts to deform. Just seating the nut is enough; the nylock feature will keep it from loosening.



Fig 216

MVC-849X

DISCHARGE CHUTE

CHUTE GEARS

Operation

The chute gears are located on top of the support tube under a cover. These gears connect the Quick Stick to the chute and provide the means to rotate the chute side to side.

Disassembly

1. To disassemble the chute gears, begin by removing the screw on the chute gear cover (Fig. 217).

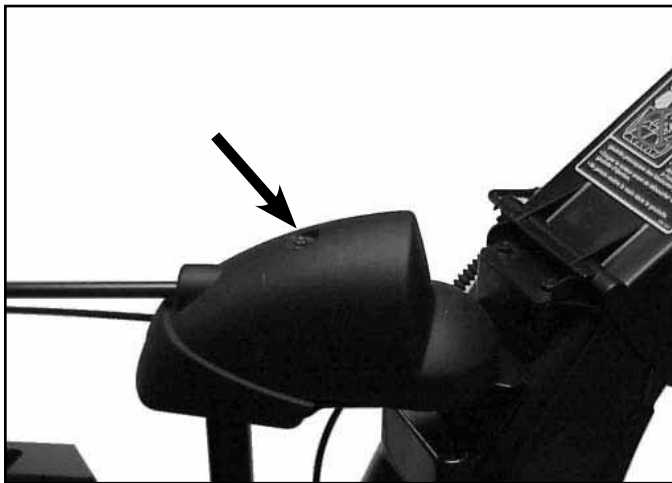

Fig 217

MVC-143X

2. Raise the front of the cover and slide it to the rear (Fig. 218).



Fig 218

MVC-144X

3. Remove the locknut and washer from the bottom of the 3 shoulder screws (Fig. 219).

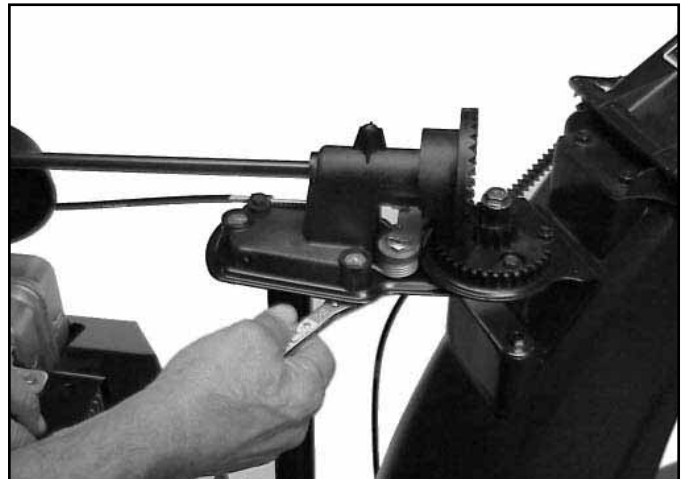

Fig 219

MVC-146X

DISCHARGE CHUTE

- Loosen the screw securing the latch cable and unhook the cable from the latch (Fig. 220).

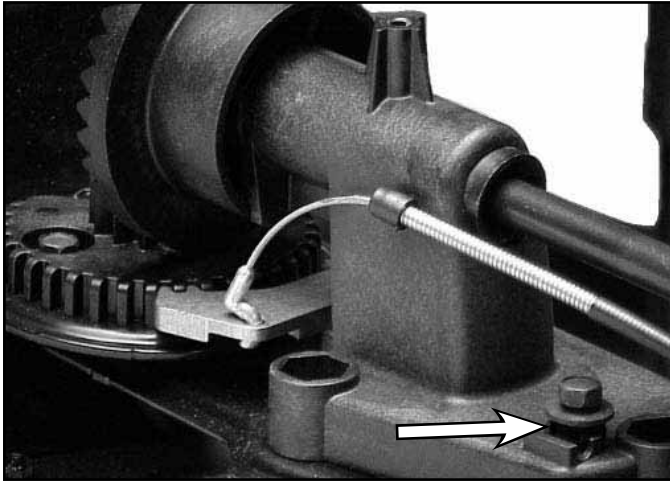

Fig 220

MVC-152X

- Remove the shoulder bolt from the chute gear (Fig. 222).



Fig 222

MVC-154X

- Raise the front of the face gear and slide it off the chute rod (Fig. 221).

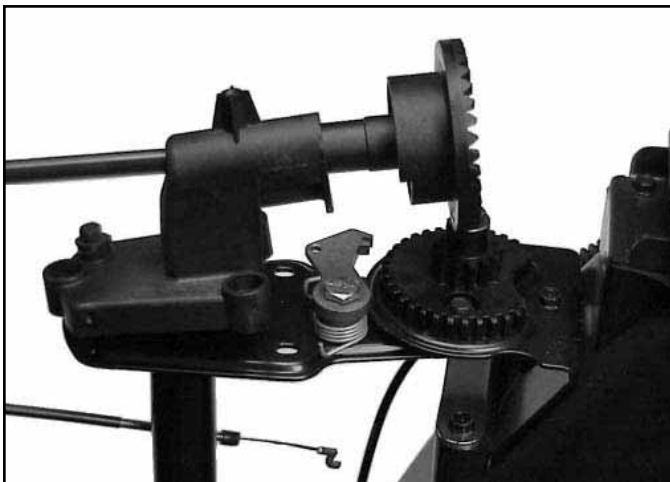

Fig 221

MVC-149X

- The chute gear is attached to the bracket by two screws. Remove the screws and lift the gear off the bracket. **Note:** a plastic spacer is under the bracket.

DISCHARGE CHUTE

Assembly

1. Attach the chute gear to the bracket with the two screws.
2. Place the spacer cupped side up on the support tube, then set the gear and bracket down on it. The shoulder bolt goes through and it secured with the washer and locknut (Fig. 223).

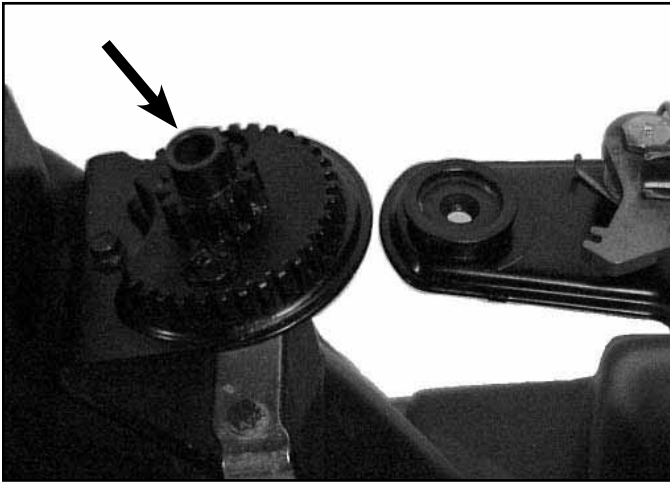

Fig 223

MVC-818X

3. Slide the face gear mount on the chute rod, if removed. Slide the face gear on the chute rod (Fig. 224).

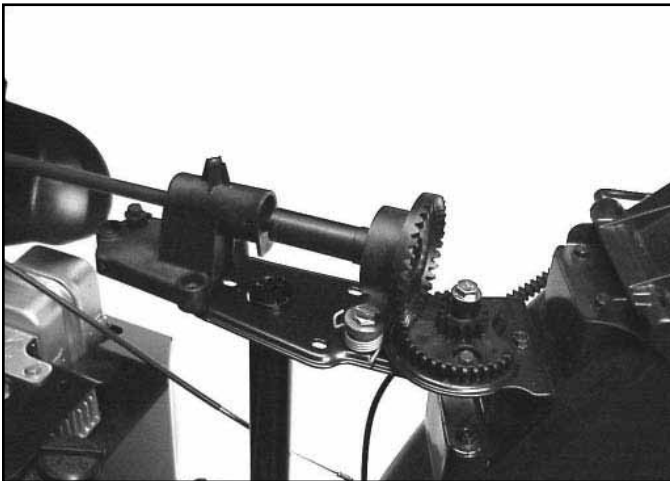

Fig 224

MVC-161X

4. The face gear has a rib molded into it and the chute gear has 2. Line up the ribs and place the face gear mount onto the support tube (Fig. 225).

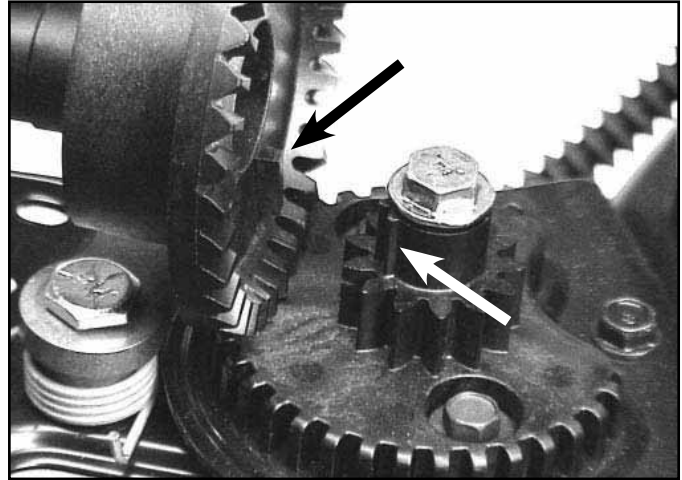

Fig 225

MVC-160X

5. One end of the spring hooks over the chute latch, the "L" end rests against the front edge of the face gear mount (Fig. 226).

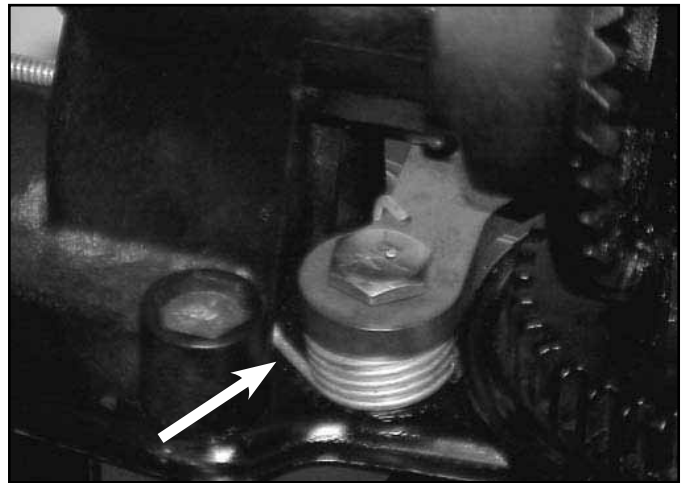

Fig 226

MVC-828X

DISCHARGE CHUTE

6. The gear lash for the chute gears must now be set. No actual measurement is necessary. The 3 shoulder bolts on the face gear mount are in slotted holes. Push the face gear mount forward to fully engage in the gears. Snug one or two of the locknuts, hold the chute latch back and rotate the chute using the quick stick (Fig. 227). It should move smoothly. If not move the face gear mount as needed. Secure the 3 locknuts.

8. Install the gear cover and screw.



Fig 227

MVC-164X

7. Install the end of the latch cable in the latch and slip the cable under the clamp screw. Pull the cable to the rear until the latch just begins to move and tighten the clamp (Fig. 228).



Fig 228

MVC-165X

THIS PAGE INTENTIONALLY LEFT BLANK

Power Max models have 3 very simple electrical systems. Each is separate from the other so a problem in one area will not affect the others.

ELECTRIC START SYSTEM

All models have an electric start system standard. All 4 cycle engines use the Tecumseh electric start system. See the Tecumseh service manual for repair information. The 2 cycle models have a Toro system. The 2 Cycle electric start is covered in the E Engine Service Manual Form # 492-0647.

LIGHTING

Some 4 cycle models have a light standard or light kit available. There is no light kit for 2 cycle models.

The lighting system consists of an alternator coil, a wire leading to the light fixture and the fixture itself. This light operates whenever the engine is running. The alternator is a Tecumseh part; replacement parts and troubleshooting assistance are obtained through the Tecumseh system.

The light fixture and the wire harness are Toro parts. The light bulb is replaceable.

IGNITION SWITCH

All models have an on/off switch.

On the 4 cycle models the switch is an engine part and is built into the carburetor heater box, next to the throttle. Use Tecumseh service information for troubleshooting and repair.

The 2 cycle models have a simple on/off switch mounted in the rear engine cover. When the key is turned off, the switch closes, the magneto primary is grounded to the engine block and the engine stops. When turned to on, the ground is disconnected allowing the ignition to fire.

The wires run from the ignition coil, under the blower housing, over the foam pad to the ignition switch. The other wire runs from the switch to the cylinder head bolt. Make sure to secure the wires to the primer line with a wire tie (Fig. 229).

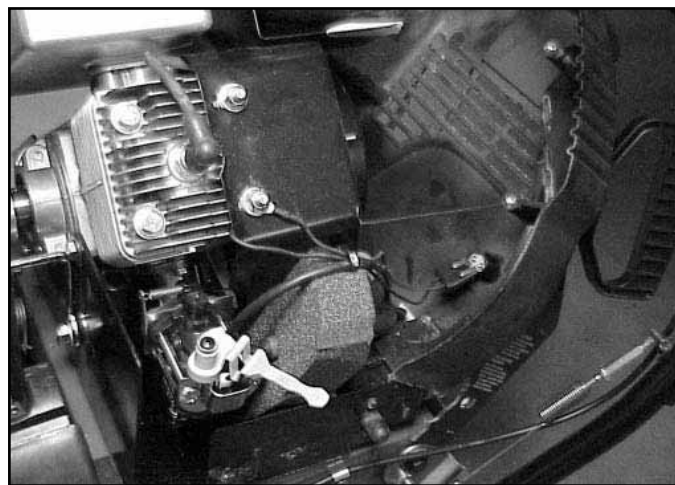

Fig 229

MVC-864X

To test the switch remove the wires and attach a continuity light or ohmmeter. When the switch is on there should be no continuity. When the switch is off there should be continuity between the terminals (Fig. 230).

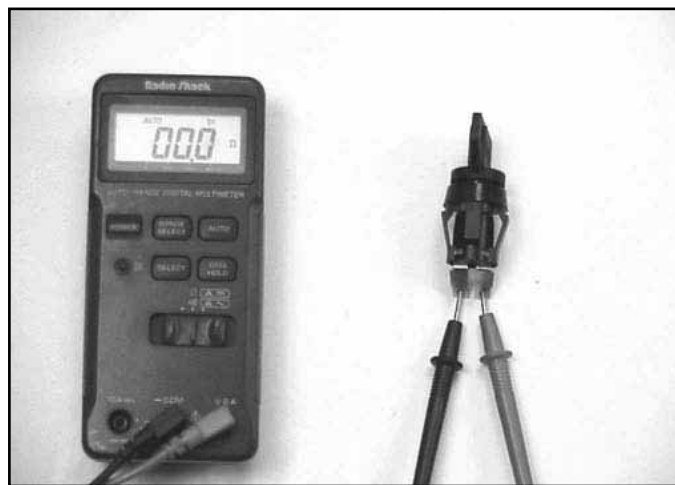

Fig 230

MVC-192

See the engine section for access to the ignition switch on 2 cycle models.

THIS PAGE INTENTIONALLY LEFT BLANK

WHEELS AND TIRES

WHEELS

There is a difference in the way the wheel is attached to the axle, depending on the drive system used.

On the standard machine the wheel is connected to the axle by a click pin. This allows the pin to be removed from the wheel and just placed in the axle. This makes the machine free wheel for easy transport. Place the pin through both the axle and wheel for self propelling (Fig. 231).



Fig 231

MVC-184X

On wheel clutch models, the wheel is attached with a bolt and locknut. The traction drive can be declutched by squeezing the levers. This provides the declutching for easy pushing (Fig. 232).



Fig 232

MVC-884Xt

TIRES

The tires on all models are 15" tubeless X-Trac tires. They are directional so they must be installed as shown, looking forward from the operator position (Fig. 233).



Fig 233

MVC-880X1

Correct Tire pressure is 17-20 psi (117-137 kPa).

Note: Tire pressure needs to be the same side-to-side or the machine will tend to pull to the side with the lower pressure.

THIS PAGE INTENTIONALLY LEFT BLANK



Power Max™ Service Manual