



Foam Marker Kit

for Multi Pro[®] 1200, 1250, 5600, 5700 Turf Sprayers and Workman[®] 200 Spray Systems

Model No. 41228—Serial No. 250000001 and Up

Installation Instructions

Note: Determine the left, right, front, and rear sides of the machine while seated in the normal operating position.

Note: If you are installing this kit on a vehicle equipped with an enclosed boom system, use these instructions along with the enclosed boom system instructions.

Note: RTV silicone sealant is used in the installation of this kit.

Loose Parts

Note: Use the chart below to identify parts for assembly.

DESCRIPTION	QTY.	USE
Tank/compressor assembly	1	Install the foam marker (you may have leftover parts, depending on which vehicle you are installing this kit on)
Workman adapter bracket	1	
Multi-Pro 1200 series adapter bracket	1	
Bolt, 3/8 x 1 inch	5	
Flange locknut, serrated, 3/8 inch	2	
Locknut 3/8 inch	1	
Carriage bolt, 3/8 x 1-1/4 inch	4	
Flange locknut, non-serrated, 3/8 inch	4	
Mixer assembly	1	
Flat washer, 3/8 inch	6	
Rocker switch	2	
Fuse, 15 amp (spare)	1	
Boom hose	2	
Punched-hole boom cap	2	
Extension hose	2	
Large hose clamp	2	
Supply hose, 108 inches	2	
Small hose clamp	6	
Plastic ties	12	
Parts Catalog	1	
Installation instructions	1	Read before installing the kit.

Setup

Separate instructions for the installation of the Foam Marker kit are provided for the Workman 200 Spray System, the Multi-Pro 1200 series sprayers, and the Multi-Pro 5000 series sprayers on the following pages:

- Workman 200 on page 2.
- Multi-Pro 1200 series on page 6.
- Multi-Pro 5000 series on page 11.

Turn the appropriate page for your machine to begin the installation.

Installing the Kit on a Workman 200 Spray System

Installing the Tank, Compressor, and Mixer

1. Remove the 4 bolts and 4 flat washers that hold the cover to the tank/compressor assembly and remove the cover (Fig. 1).

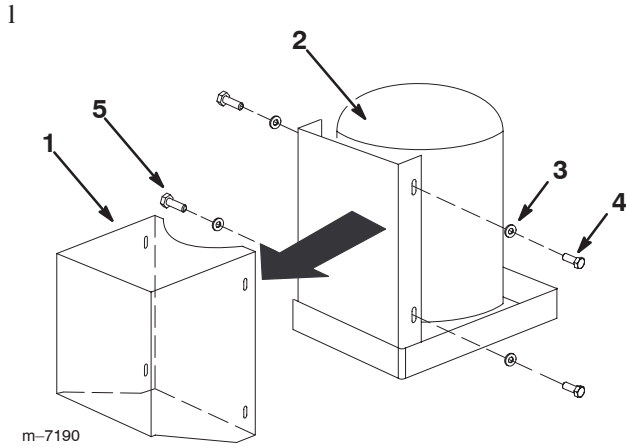

Figure 1

- | | |
|-----------------------------|----------------------|
| 1. Cover | 3. Flat washer |
| 2. Tank/compressor assembly | 4. Bolt |
| | 5. Bottom right bolt |

2. Set the cover and fasteners aside.
3. Mark a 108 inch supply hose with a black marker at each end (Fig. 2).
4. Connect the marked supply hose to the hose barb at the compressor and the other supply hose to the hose barb on the needle valve (Fig. 2).

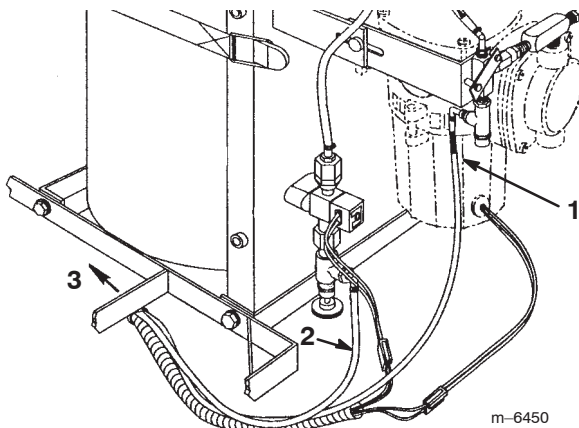

Figure 2

- | | |
|----------------------|---------------------|
| 1. Compressor hose | 3. To the mixer tee |
| 2. Needle valve hose | |

5. Secure the hose ends with small hose clamps.
6. Route both of the supply hoses rearward along the left side of the sprayer to the rear of the machine following the sprayer wiring harness.
7. Attach the cover to the tank/compressor assembly using 3 of the 4 hex-head bolts (1/4 x 1 inch) and flat washers that you removed previously. Leave the bottom right bolt out until later in the installation (Fig. 1).
8. Mount the Workman adapter bracket supplied in the kit to the tank/compressor assembly using 2 bolts (3/8 x 1 inch), 2 flat washers (3/8 inch) as shown figure 3.

Note: If necessary, cut back the rubber trim on the cover so that it does not interfere when mounting the bracket to the tank/compressor assembly.

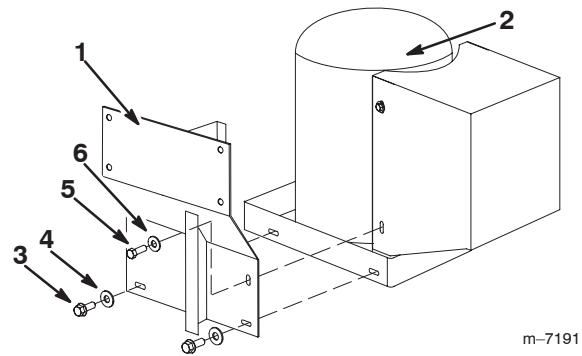

Figure 3

- | | |
|-----------------------------|----------------|
| 1. Workman adapter bracket | 4. Flat washer |
| 2. Tank/compressor assembly | 5. Bolt |
| 3. Bolt, 3/8 x 1 inch | 6. Flat washer |

9. Install the remaining bolt (1/4 x 1 inch) and flat washer (1/4 inch) through the Workman adapter bracket and cover into the tank/compressor assembly (Fig. 3).
10. Remove the left handle and fasteners from the left side of the tank skid. Save fasteners for later use.

11. Mount the foam marker assembly to the frame using two bolts (3/8 x 1 inch), two washers (3/8 inch), two flange nuts (3/8 inch) included in loose parts; and the left handle and fasteners removed previously (Fig. 4).

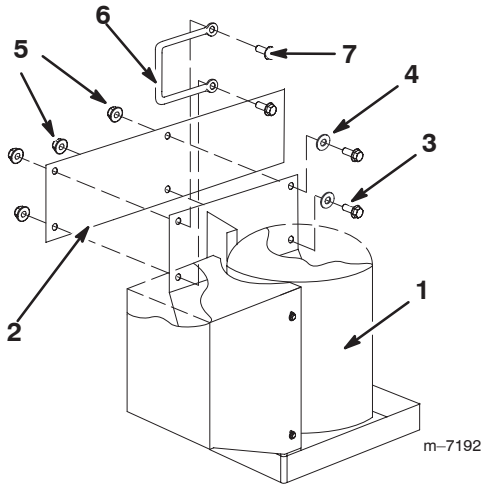

Figure 4

- | | |
|-------------------------|-----------------------------------|
| 1. Foam marker assembly | 5. Flange nut(serrated), 3/8 inch |
| 2. Frame | 6. Left sprayer handle |
| 3. Bolt, 3/8 x 1 inch | 7. Fasteners |
| 4. Washer, 3/8 inch | |

Note: Rotate the tank so that the handle is closest to the frame.

12. At the rear of the machine, mount the mixer assembly to the angle on the center boom assembly with a bolt (3/8 x 1 inch), flat washer, and locknut (Fig. 5).

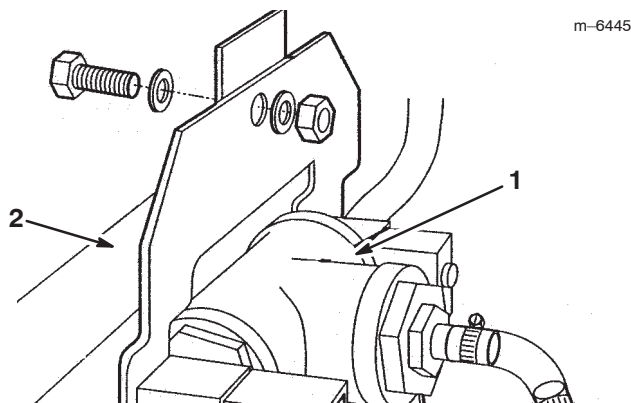

Figure 5

- | | |
|-----------------------|----------------|
| 1. Mixer tee assembly | 2. Center boom |
|-----------------------|----------------|

Note: If necessary, rotate the mixer assembly down so that it does not interfere with the pump.

13. Slide the marked supply hose onto the barb on the check valve located at the tee assembly (Fig. 6).

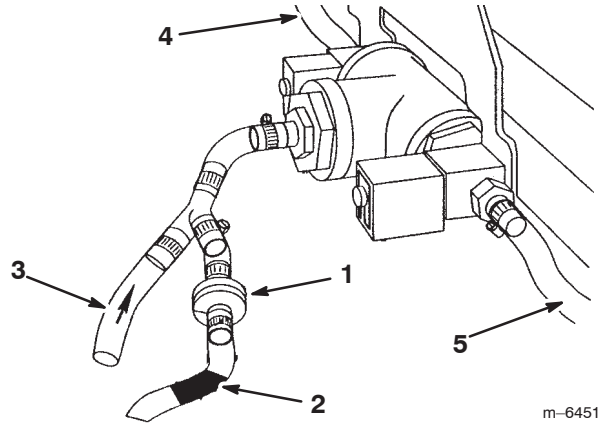

Figure 6

- | | |
|-------------------------------|--------------------|
| 1. Check valve | 4. Right boom hose |
| 2. Hose from the compressor | 5. Left boom hose |
| 3. Hose from the needle valve | |

14. Connect the other supply hose to the barbed "Y" at the tee assembly (Fig. 6).

15. Secure the hoses with small hose clamps.

16. Connect the right boom hose to the right side solenoid valve assembly and the left supply hose to the left side solenoid assembly.

17. Secure both hoses with small hose clamps (Fig. 6).

Wiring the Kit

1. Locate the wiring harness and make the connections to the compressor and the solenoid located at the foam tank/compressor assembly (Fig. 7).

Note: Both of the plug connections are identical (Fig. 7).

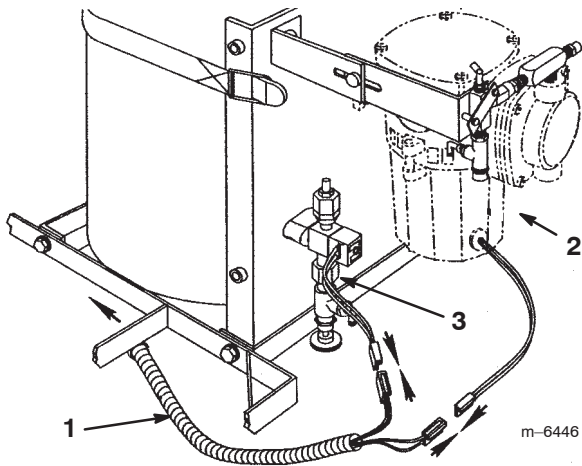

Figure 7

- 1. Wiring harness
- 2. Compressor
- 3. Solenoid

2. Locate the connectors in the rear wiring harness of the sprayer (Fig. 8).

- A. Plug the connector with the yellow/blue wire into the left boom solenoid.
- B. Plug the connector with the blue/green wire into the right boom solenoid.

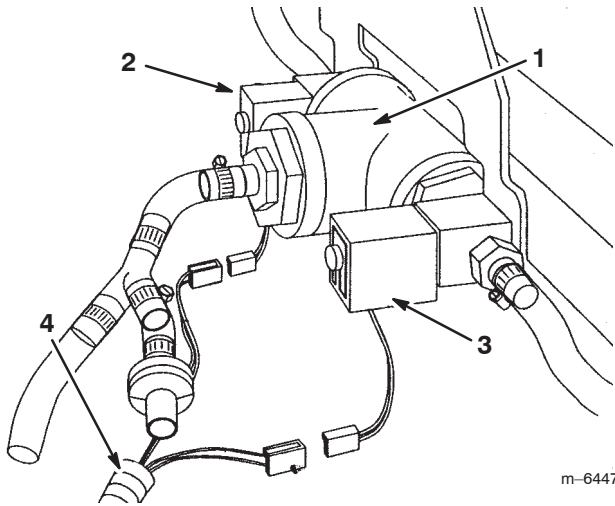

Figure 8

- 1. Mixer tee assembly
- 2. Boom solenoid, right
- 3. Boom solenoid, left
- 4. Wiring harness

3. Route the hoses along the wiring harness to the rear of the sprayer and to the mixer tee using the cable ties. Secure the hose end with a small hose clamp.

Installing the Switches

- 1. Loosen the 4 screws securing the front panel to the control box (Fig. 9).
- 2. Remove the front panel expose the inside of the control box (Fig. 9).

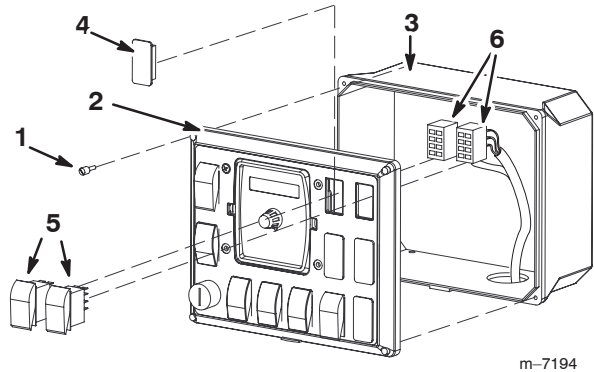

Figure 9

- 1. Screw
- 2. Front panel
- 3. Control box
- 4. Plug
- 5. Rocker Switch
- 6. Connectors

3. Lift and remove the 2 plugs from the spray control panel on the vehicle and install the 2 rocker switches provided in their place (Fig. 9).

4. Plug the connector with the yellow/blue wire to the left switch and the connector with the blue/green wire to the right switch.

Note: Ensure that the orientation of the switches mates with the orientation of the connector.

5. Install the front control panel to the control box and secure it with the 4 screws loosened previously.

6. Insert the 15-amp fuse in the top slot in the fuse block. Make sure the corresponding wire in the fuse block is connected to the red/black wire in the harness (Fig. 10).

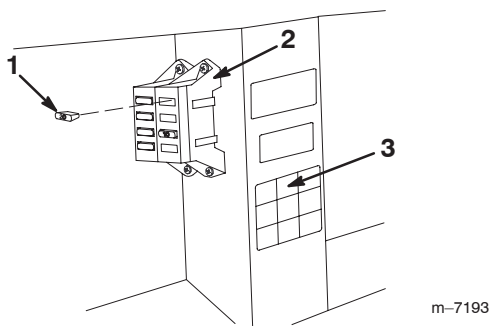

Figure 10

1. 15-amp
2. Fuse block
3. Fuse box decal

Completing the Installation

Note: If you are installing this kit on a previously setup sprayer, you may need to disassemble the boom assembly for steps 1 through 10 below.

1. Locate, mark, and drill (through the top surface only) a hole (5/8 inch dia) 1-1/2 inch from the plugged end of the right boom pipe (Fig. 11).

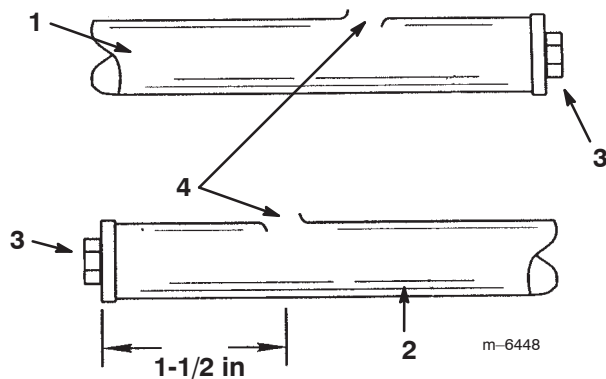

Figure 11

1. Left boom pipe
2. Right boom pipe
3. Boom plug
4. Hole, 5/6 inch, drilled, deburred, and distorted

2. Repeat step 1 for the left boom pipe.
3. Use a round file or deburring tool to deburr the holes you drilled in the boom pipes (Fig. 11).
4. Insert a drift punch into the 5/8 inch holes in the boom pipes and distort the openings as shown in Figure 11.

Note: This allows you to install the boom hoses more easily.

5. Remove the existing boom cap from the end of the boom pipe.
6. Insert the boom hose into the hole drilled in the right boom pipe and push it into the boom pipe until **2 to 3 inches** of boom hose **extends beyond** the opposite end of the boom pipe (Fig. 12).

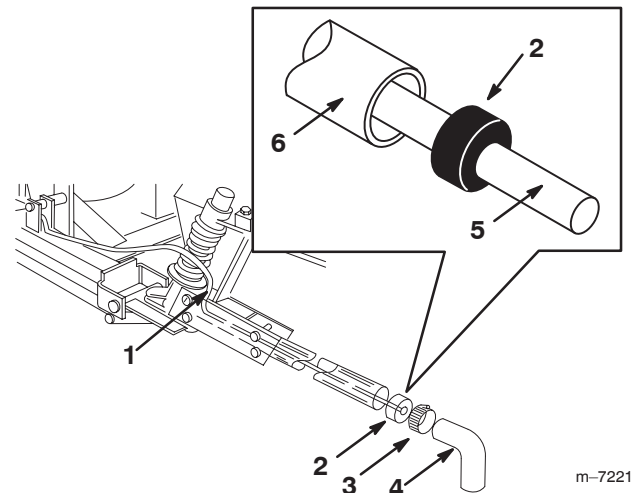

Figure 12

1. Boom hose
2. Punched hole boom cap
3. Hose clamp
4. Extension hose
5. 2 to 3 inches of boom hose past the boom cap
6. End of the boom pipe

7. Push the boom hose through the punched hole boom cap until it **extends 2 to 3 inches past the cap** (Fig. 12).
8. Install the boom cap into the end of the boom pipe (Fig. 12).
9. Lubricate the inside of the extension hose and slide it over the cap and boom hose and onto the boom pipe (Fig. 12).
10. Secure the extension hose onto the boom pipe with a large hose clamp (Fig. 12).
11. Repeat steps 5 through 10 for the left boom pipe.
12. Seal the 5/8 inch holes on each boom pipe with RTV silicone after you completely assemble the hoses and boom pipes.
13. Ensure that the marked supply hose is connected at the compressor and the check valve. If not, correct it before using (Fig. 6).
14. Secure all loose wires and hoses to the vehicle frame using plastic ties.
15. Close the foam density adjustment valve completely.

Installing the Kit on a Multi Pro 1200 or 1250 Turf Sprayer

Installing the Tank, Compressor, and Mixer

1. Mount the Multi-Pro 1200 series adapter bracket to the right side of the vehicle above the battery (Fig. 13) using 4 bolts (3/4 x 1-1/4 inch) and 4 flange locknuts (3/4 inch).

Note: It is easiest if you remove the battery before performing this step. Refer to your vehicle *Operator's Manual* for instructions.

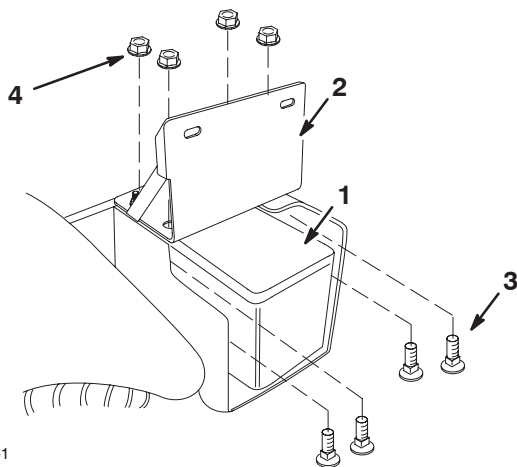

Figure 13

- | | |
|--|---|
| 1. Battery | 4. Flange locknut(non-serrated), 3/4 inch |
| 2. Multi-Pro 1200 series adapter bracket | |
| 3. Carriage bolt, 3/4 x 1-1/4 inch | |

2. Remove the 4 bolts and flat washers that hold the cover to the tank/compressor assembly and remove the cover (Fig. 14).

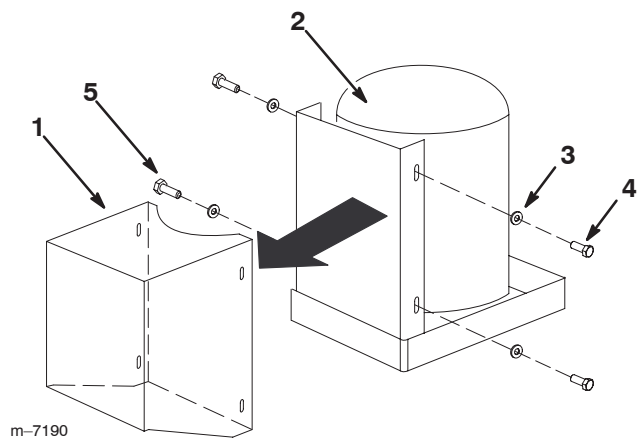

Figure 14

- | | |
|-----------------------------|----------------------|
| 1. Cover | 3. Flat washer |
| 2. Tank/compressor assembly | 4. Bolt |
| | 5. Bottom right bolt |

3. Set the cover and fasteners aside.
4. Mark a 108 inch supply hose with a black marker at each end (Fig. 15).
5. Connect the marked supply hose to the hose barb at the compressor and the other supply hose to the hose barb on the needle valve (Fig. 15).

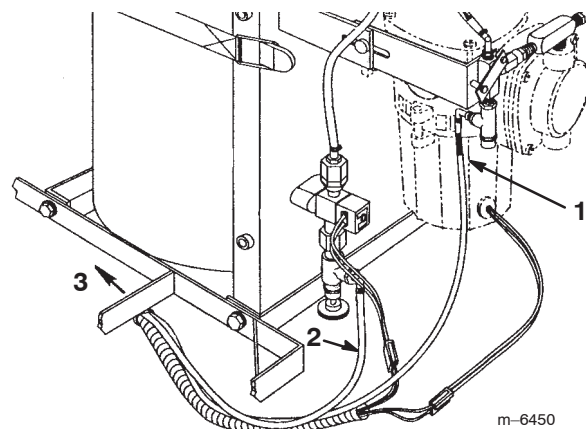

Figure 15

- | | |
|----------------------|---------------------|
| 1. Compressor hose | 3. To the mixer tee |
| 2. Needle valve hose | |

6. Secure the hose ends with small hose clamps.
7. Route both of the supply hoses rearward along the right side of the sprayer to the rear of the machine following the sprayer wiring harness.
8. Attach the cover to the tank/compressor assembly using 4 hex-head bolts (1/4 x 1 inch) and 4 flat washers that you removed previously.
9. Install the tank/compressor assembly to the Multi-Pro 1200 series adapter bracket using 2 bolts (3/8 x 1 inch), 2 flat washers (3/8 inch) as shown Figure 16.

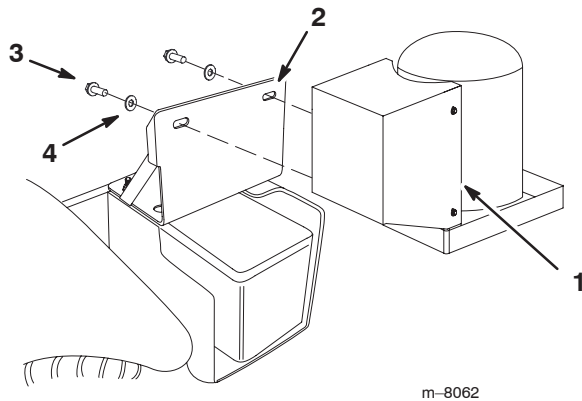

Figure 16

- | | |
|--|-----------------------|
| 1. Tank/compressor assembly | 3. Bolt, 3/8 x 1 inch |
| 2. Multi-Pro 1200 series adapter bracket | 4. Flat washer |

10. At the rear of the machine, mount the mixer assembly to the angle on the center boom assembly with a bolt (3/8 x 1 inch), flat washer, and locknut (Fig. 17).

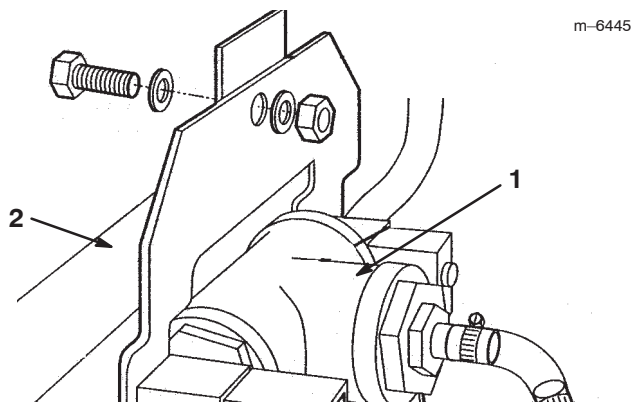

Figure 17

- | | |
|-----------------------|----------------|
| 1. Mixer tee assembly | 2. Center boom |
|-----------------------|----------------|

11. Locate the supply hoses routed to the rear of the machine previously.
12. Slide the marked supply hose onto the barb on the check valve located at the tee assembly (Fig. 18).

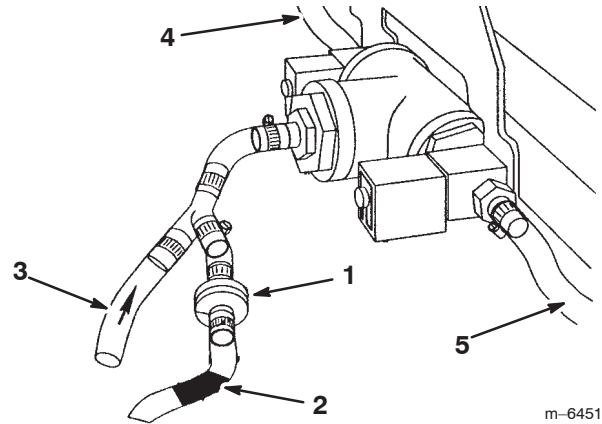

Figure 18

- | | |
|-------------------------------|--------------------|
| 1. Check valve | 4. Right boom hose |
| 2. Hose from the compressor | 5. Left boom hose |
| 3. Hose from the needle valve | |

13. Connect the other supply hose to the barbed "Y" at the tee assembly (Fig. 18).

14. Secure the hoses with small hose clamps.

Installing the Switches

1. Remove the spray control panel to expose the bottom side (Fig. 19 for the 1250 and Fig. 20 for the 1200).
2. Lift and remove the 2 plugs from the spray control panel on the vehicle and install the 2 rocker switches provided in their place (Fig. 19 for the 1250 and Fig. 20 for the 1200).
3. Plug the connector with the yellow wire for the right foam solenoid to the right switch and the connector with the blue wire for the left foam solenoid to the left switch.

Note: Ensure that the orientation of the switches matches what is shown in Figure 19, with the notch pointing toward the rear of the vehicle.

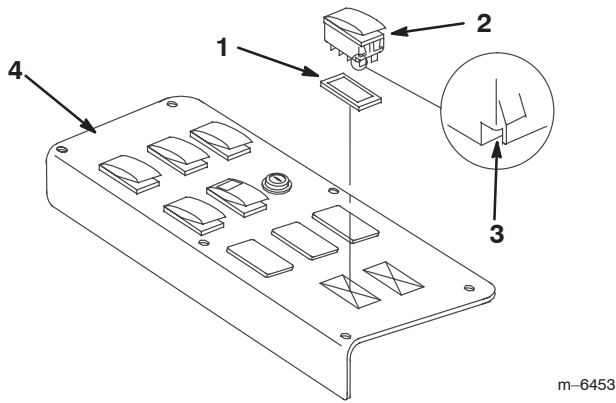

Figure 19

- 1. Plug
- 2. Switch
- 3. Notch (at back)
- 4. Spray control panel

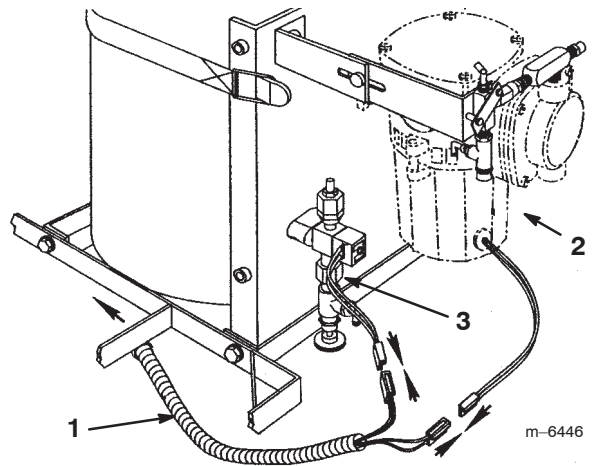

Figure 21

- 1. Wiring harness
- 2. Compressor
- 3. Solenoid

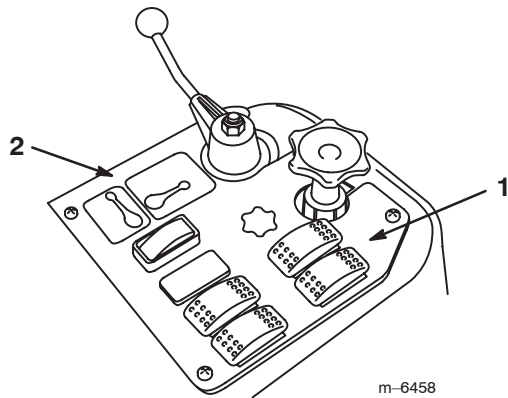

Figure 20

- 1. Foam marker switches
- 2. Spray control panel

Wiring the Kit

1. Locate the labeled connectors wiring harness for the foam marker solenoid and compressor and make the connections to the compressor and the solenoid located at the foam tank/compressor assembly (Fig. 21).

Note: Both of the plug connections are identical (Fig. 21).

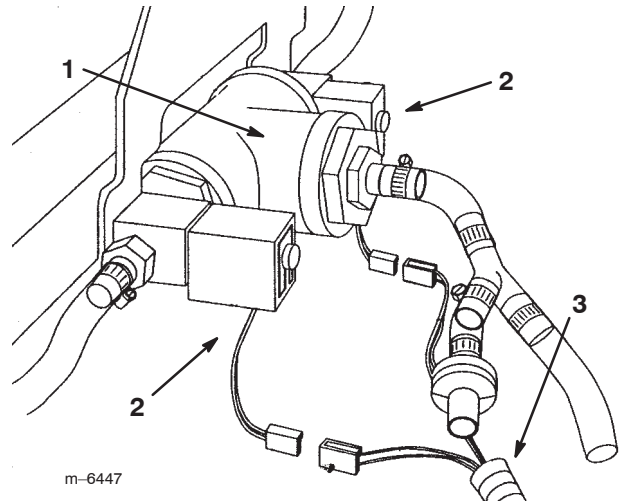

Figure 22

- 1. Mixer tee assembly
- 2. Boom solenoids
- 3. Wiring harness

Completing the Installation

Note: If you are installing this kit on a previously setup sprayer, you may need to disassemble the boom assembly for steps 1 through 10 below.

1. Locate, mark, and drill (through the top surface only) a hole (5/8 inch dia) 1-1/2 inch from the plugged end of the right boom pipe (Fig. 23).
2. Repeat step 1 for the left boom pipe.
3. Use a round file or deburring tool to deburr the holes you drilled in the boom pipes (Fig. 23).
4. Insert a drift punch into the 5/8 inch holes in the boom pipes and distort the openings as shown in Figure 23.

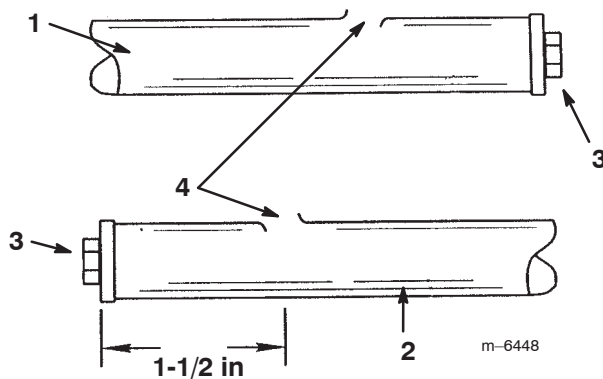
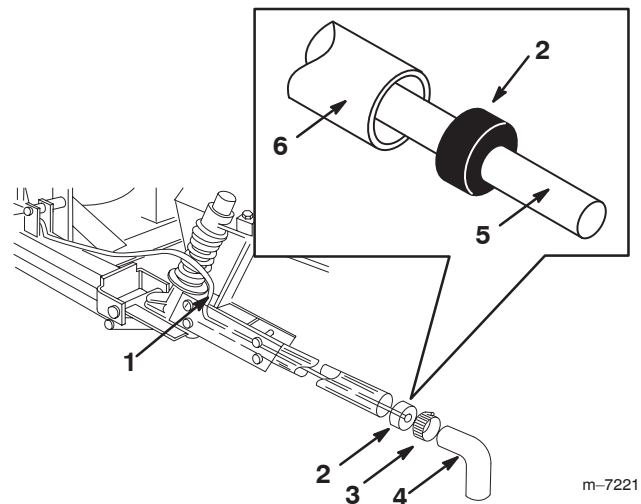

Figure 23

1. Left boom pipe
2. Right boom pipe
3. Boom plug
4. Hole, 5/8 inch, drilled, deburred, and distorted

Note: This allows you to install the boom hoses more easily.

5. Remove the existing boom cap from the end of the boom pipe.
6. Insert the boom hose into the hole drilled in the right boom pipe and push it into the boom pipe until **2 to 3 inches** of boom hose **extends beyond** the opposite end of the boom pipe (Fig. 24).



m-7221

Figure 24

1. Boom hose
 2. Punched hole boom cap
 3. Hose clamp
 4. Extension hose
 5. 2 to 3 inches of boom hose past the boom cap
 6. End of the boom pipe
7. Push the boom hose through the punched hole boom cap until it **extends 2 to 3 inches past the cap** (Fig. 24).
 8. Install the boom cap into the end of the boom pipe (Fig. 24).
 9. Lubricate the inside of the extension hose and slide it over the cap and boom hose and onto the boom pipe (Fig. 24).
 10. Secure the extension hose onto the boom pipe with a large hose clamp (Fig. 24).
 11. Repeat steps 5 through 10 for the left boom pipe.
 12. Seal the 5/8 inch holes on each boom pipe with RTV silicone after you completely assemble the hoses and boom pipes.
- Important** If you set up the foam marker kit during the initial setup of the turf sprayer, refer to the Setup Instructions for the vehicle for the final assembly instructions of the booms before continuing with step 13.
13. Ensure that the marked supply hose is connected at the compressor and the check valve. If not, correct it before using (Fig. 25).

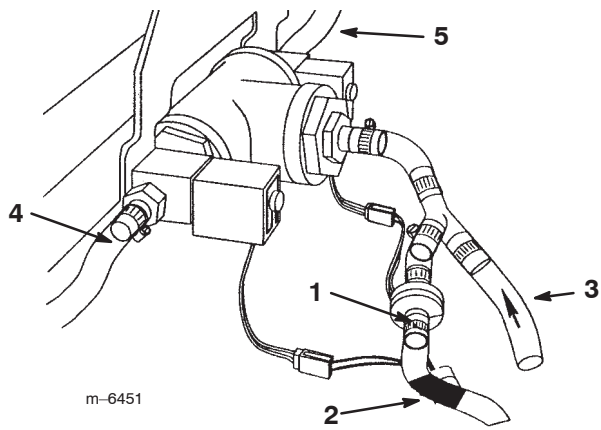

Figure 25

- | | |
|-------------------------------|--------------------|
| 1. Check valve | 4. Right boom hose |
| 2. Hose from the compressor | 5. Left boom hose |
| 3. Hose from the needle valve | |

14. Connect the right boom hose to the right side solenoid valve assembly and the left supply hose to the left side solenoid assembly.

15. Secure both hoses with small hose clamps (Fig. 25).

16. Secure all loose wires and hoses to the vehicle frame using plastic ties.

17. Attach the cover to the tank/compressor assembly using the 4 hex-head bolts (1/4 x 1 inch) and flat washers that you removed previously.

18. Close the foam density adjustment valve completely.

Installing the Kit on a Multi Pro 5600/5700 Turf Sprayer

Installing the Tank, Compressor, and Mixer

1. Remove 4 bolts (1/4 x 1 inch) and flat washers that hold the cover to the tank/compressor assembly.
2. Remove the cover.
3. Set the cover and fasteners aside.
4. Mount the tank/compressor assembly to the right step frame using 2 bolts (3/8 x 1 inch) and flat washers (Fig. 26).

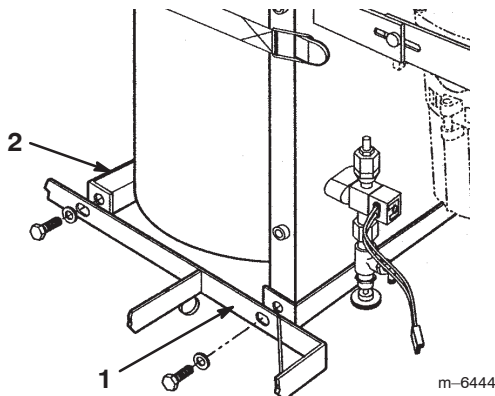

Figure 26

1. Right step frame
2. Tank assembly frame

Note: You must install the fasteners from the backside of the step frame.

5. Mount the mixer assembly to the angle on the center boom assembly with a bolt (3/8 x 1 inch), flat washer, and a locknut (Fig. 27).

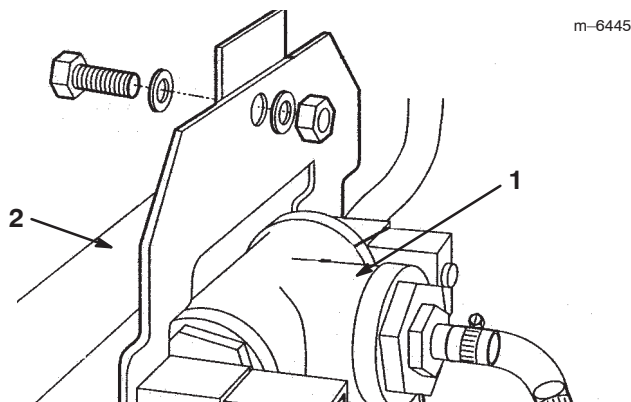

Figure 27

1. Mixer tee assembly
2. Center boom angle

Installing the Switches

1. Remove the throttle knob by unscrewing it from the throttle rod at the center console.
2. Release the latch and remove the switch panel assembly from the center console assembly (Fig. 28).

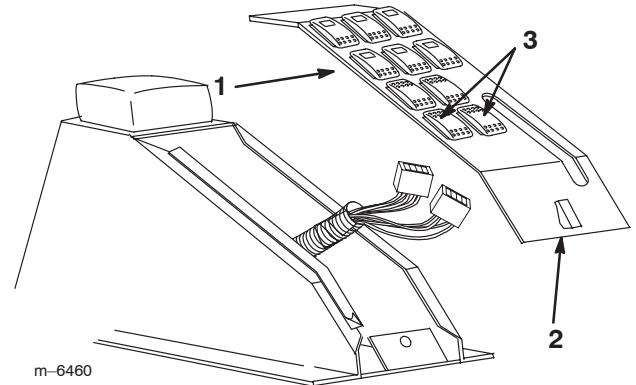

Figure 28

1. Control panel
2. Latch
3. Foam marker switches

3. Remove the foam marker switch hole plugs.
4. Install the 2 rocker switches into the switch panel.

Note: Ensure that the notch/hole on the bottom of each switch is oriented toward the rear of the vehicle.

5. Plug the harness connectors found in the center console into the foam marker switches.

Note: The plugs in the harness are marked: Boom foam RS/LS switch. The left connector has a yellow wire with a blue stripe and the right connector has a blue wire with a gray stripe.

6. Install the switch panel and secure the latch.
7. Screw the throttle knob onto the throttle rod until it is hand tight.
8. Locate the wiring harness connectors furnished with the vehicle for the foam marker and make the connections to the compressor and the solenoid located at the foam tank/compressor assembly (Fig. 29).

Note: The connectors are located along the right side frame rail strapped to the vehicle harness, where the tank/compressor is installed. Both of the plug connections are identical (Fig. 29).

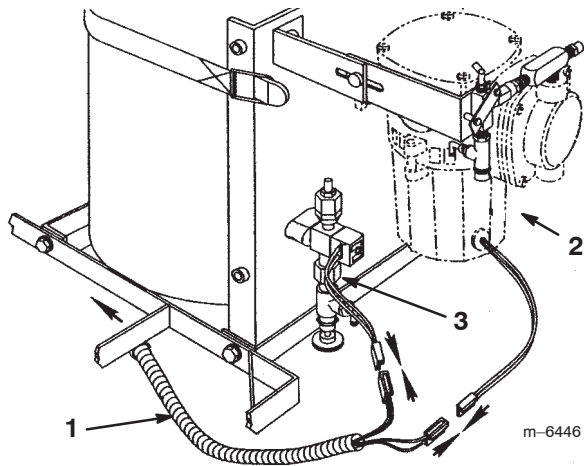

Figure 29

- 1. Wiring harness
- 2. Compressor
- 3. Solenoid

9. Locate the wiring harness connector furnished with the vehicle for the foam marker boom solenoid at the center section of the boom (Fig. 30).

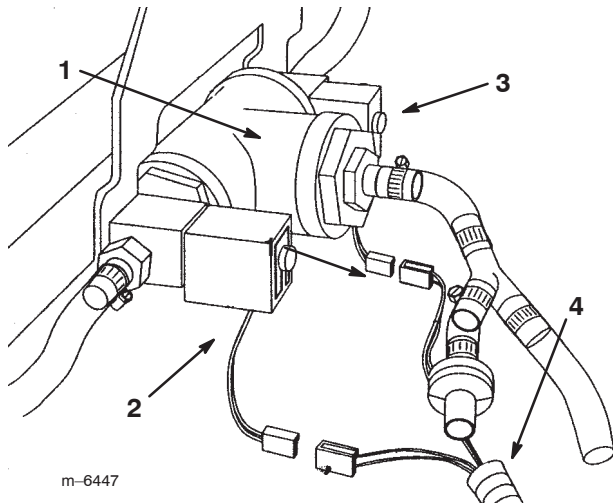

Figure 30

- 1. Mixer tee assembly
- 2. Boom solenoid, right
- 3. Boom solenoid, left
- 4. Wiring harness

10. Plug the harness connectors into the boom solenoids at the mixer tee assembly. Plug the connector with the blue wire to the right solenoid and plug the connector with the yellow wire to the left solenoid (Fig. 30).

11. Insert the 20-amp fuse in the second fuse slot in the block (from the front of the vehicle).

To complete the installation, refer to Completing the Installation, page 12.

Completing the Installation

Note: If you are installing this kit on a previously setup sprayer, you may need to disassemble the boom assembly for steps 1 through 10 below.

1. Locate, mark, and drill (through the top surface only) a hole (5/8 inch dia) 1-1/2 inch from the plugged end of the right boom pipe (Fig. 31).
2. Repeat step 1 for the left boom pipe.
3. Use a round file or deburring tool to deburr the holes you drilled in the boom pipes (Fig. 31).
4. Insert a drift punch into the 5/8 inch holes in the boom pipes and distort the openings as shown in Figure 31.

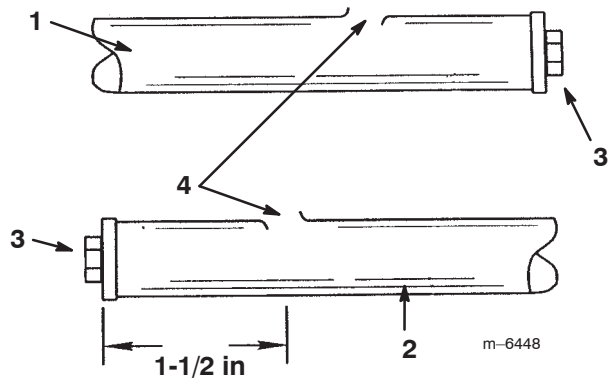

Figure 31

- 1. Left boom pipe
- 2. Right boom pipe
- 3. Boom plug
- 4. Hole, 5/6 inch, drilled, deburred, and distorted

Note: This allows you to install the boom hoses more easily.

5. Remove the existing boom cap from the end of the boom pipe.
6. Insert the boom hose into the hole drilled in the right boom pipe and push it into the boom pipe until **2 to 3 inches** of boom hose **extends beyond** the opposite end of the boom pipe (Fig. 32).

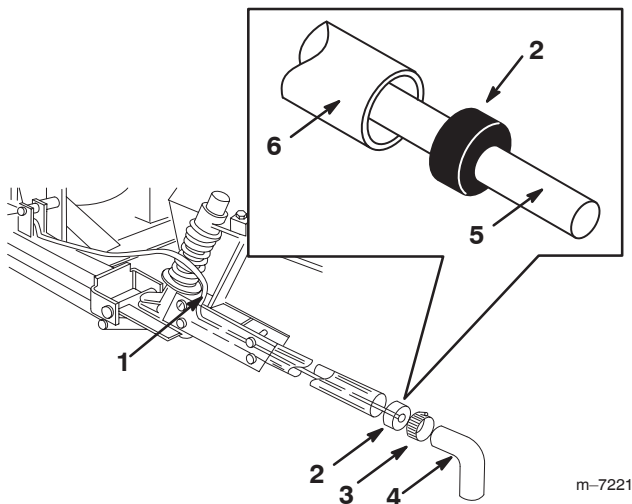

Figure 32

- | | |
|--------------------------|---|
| 1. Boom hose | 5. 2 to 3 inches of boom hose past the boom cap |
| 2. Punched hole boom cap | 6. End of the boom pipe |
| 3. Hose clamp | |
| 4. Extension hose | |

7. Push the boom hose through the punched hole boom cap until it **extends 2 to 3 inches past the cap** (Fig. 32).
8. Install the boom cap into the end of the boom pipe (Fig. 32).
9. Lubricate the inside of the extension hose and slide it over the cap and boom hose and onto the boom pipe (Fig. 32).
10. Secure the extension hose onto the boom pipe with a large hose clamp (Fig. 32).
11. Repeat steps 5 through 10 for the left boom pipe.
12. Seal the 5/8 inch holes on each boom pipe with RTV silicone after you completely assemble the hoses and boom pipes.

Important If you set up the foam marker kit during the initial setup of the turf sprayer, refer to the Setup Instructions for the vehicle for the final assembly instructions of the booms before continuing with step 13.

13. Mark a 108 inch supply hose with a black marker at each end (Fig. 33).
14. Connect the marked supply hose to the hose barb at the compressor and the other supply hose to the hose barb on the needle valve (Fig. 33).

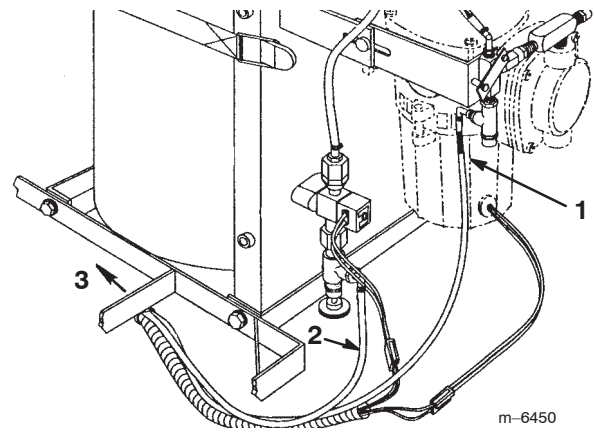

Figure 33

- | | |
|----------------------|---------------------|
| 1. Compressor hose | 3. To the mixer tee |
| 2. Needle valve hose | |

15. Secure the hose ends with small hose clamps (Fig. 33).
16. Route both of the supply hoses rearward along the right side of the vehicle frame to the mixer tee following the foam marker wiring harness.
17. Slide the marked supply hose onto the barb on the check valve located at the tee assembly.
18. Connect the other supply hose to the barbed "Y" at the tee assembly.
19. Secure the hoses with small hose clamps.
20. Ensure that the marked supply hose is connected at the compressor and the check valve. If not, correct it before using (Fig. 34).

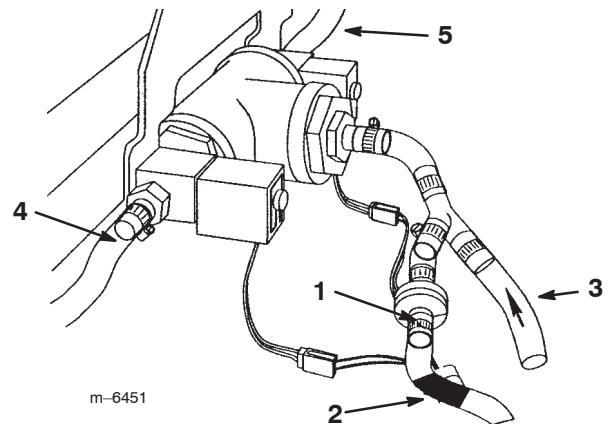

Figure 34

- | | |
|-------------------------------|--------------------|
| 1. Check valve | 4. Right boom hose |
| 2. Hose from the compressor | 5. Left boom hose |
| 3. Hose from the needle valve | |

- 21.** Connect the right boom hose to the right side solenoid valve assembly and the left supply hose to the left side solenoid assembly.
- 22.** Secure both hoses with small hose clamps (Fig. 34).
- 23.** Secure all loose wires and hoses to the vehicle frame using plastic ties.
- 24.** Attach the cover to the tank/compressor assembly using the 4 hex-head bolts (1/4 x 1 inch) and flat washers that you removed previously.
- 25.** Close the foam density adjustment valve completely.

Safety and Instruction Decals



Safety decals and instructions are easily visible to the operator and are located near any area of potential danger. Replace any decal that is damaged or lost.

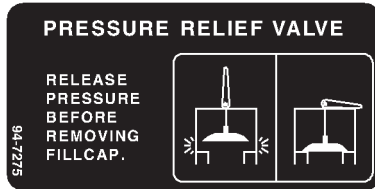

94-7275

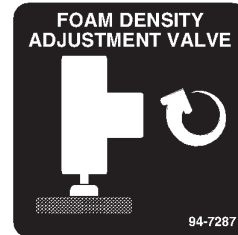

94-7287

Operation

Using the Controls

Right boom switch—activates the compressor, generating a flow of foam to the right boom section.

Left boom switch—activates the compressor, generating a flow of foam to the left boom section.

Note: You can drop the foam simultaneously from both boom sections.

Sight gauge— indicates the solution level in the tank. It is located on the side of the tank

Foam density adjustment valve—controls the consistency of the foam solution. Setting the valve to Decreasing lowers the water content, allowing the markers to hold its shape. Setting the valve to Increasing creates a more watery marker.

Note: On a windy day, a watery marker consistency may be helpful.

Pressure relief valve—When it is in the upright position, it relieves the pressure in the foam solution tank.

Filling the Tank and Adjusting the Foam Density

1. Ensure that both the left and right boom switches located on the console are in the Off position.

Caution

The contents of the foam marker tank are under pressure. Loosening the fittings on the tank could result in personal injury.

Flip the pressure relief valve into the Up position.

2. Flip the pressure relief valve to the upright position (Fig. 35).

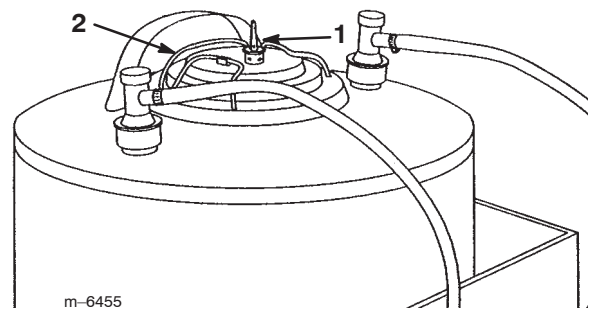

Figure 35

1. Pressure relief valve 2. Lid clamp

3. Pull up on the lid clamp, turn the lid 90 degrees, and remove it from the tank.

4. Pour the proper amount water and foam concentrate through the opening in the top of the tank according to the manufacturer's instructions.

Important Do not add more than 2-1/2 gallons (9.5 l) of solution into the tank.

Note: Extreme pH levels (hardness/softness) of the water will affect the amount of foam concentrate needed.

5. Install the lid on the solution tank.
6. Ensure that the lid is positioned properly for a tight seal and push down on the clamp lid.
7. Close the pressure relief valve.
8. For the initial operation, open the foam density adjustment valve 1/8 to 1/4 turn (Fig. 36).
9. Start operating the marking system and make a test pattern on the ground. When you first start the marking system, allow 1 to 2 minutes for the foam to flow through the line.
10. Adjust the foam density adjustment valve to obtain the desired consistency and spray as normal.

Note: If you leave the foam in the line for more than 2 hours, it may become watery. Before operating after a break of 2 or more hours, run the machine for 1 to 2 minutes to remove the excess water.

Note: The mixer tee can flood if the solution-to-air mixture is too rich, producing watery foam. If the foam is too dry, the flow will be unsteady with high-pressure surges.

If the foam in the machine is very watery, do the following:

- A. Close the foam density adjustment valve completely.
- B. Operate for 2 minutes.
- C. Wait 1 minute and then check the consistency of the foam.
- D. Adjust the foam to achieve the desired consistency.

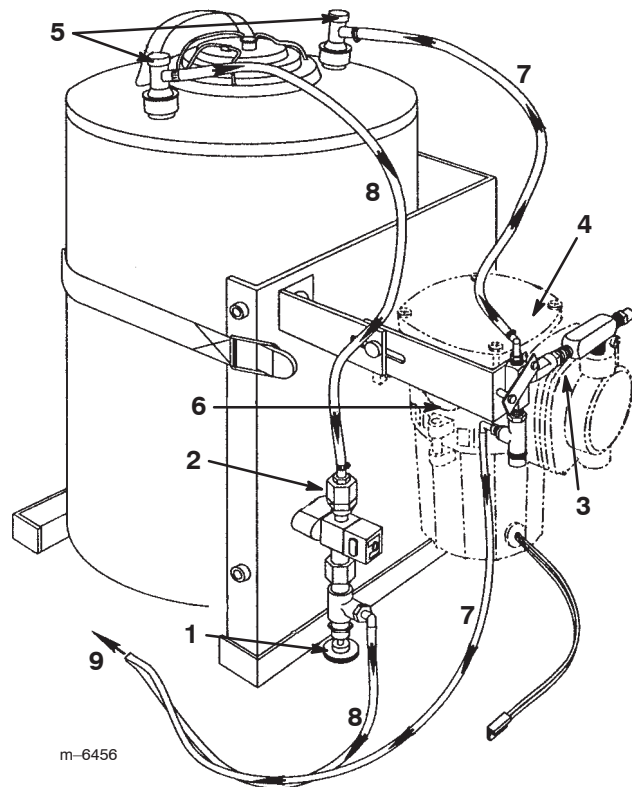

Figure 36

- | | |
|----------------------------------|-----------------|
| 1. Foam density adjustment valve | 5. Couplers |
| 2. Strainer | 6. Air filter |
| 3. Check valve | 7. Air only |
| 4. Compressor | 8. Liquid |
| | 9. To mixer tee |

Maintenance

Note: Determine the left and right sides of the machine from the normal operating position.

Recommended Maintenance Schedule

Maintenance Service Interval	Maintenance Procedure
100 Hours	<ul style="list-style-type: none"> Inspect the hose between the foam tank and the compressor for accumulated water. Inspect and clean the check valve in the tee on top of the compressor. Replace the valve if necessary. Remove and clean the strainer at the top of the solenoid valve, next to the compressor. Ensure that the bottom of the compressor is free from debris.
250 Hours	<ul style="list-style-type: none"> Replace the compressor air filter. Check for and rinse out debris from the inside of the tank.
500 Hours	<ul style="list-style-type: none"> Replace the plastic check valve at the "Y" near the mixer tee assembly, located at the rear of the vehicle, on the center boom (Fig. 37).

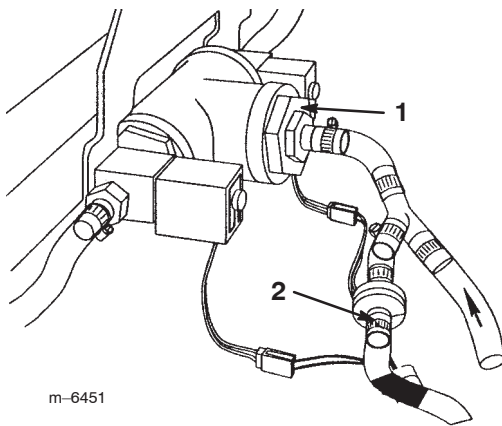

m-6451

Figure 37

1. Mixer tee
2. Check valve

Cleaning Strainer

Important Dried foam agent and debris can clog the strainer (Fig. 38), causing slow or no foam production. This can be mistaken for a bad foam pump or incorrect foam mix. If experiencing slow or no foam production, remove and clean the strainer.

1. Position the vehicle on a level surface, set the parking brake, stop the pump, stop the engine, and remove the ignition key.
2. Relieve pressure within tank by flipping the pressure release valve into the upright position. (Fig. 35)
3. Clamp liquid hose and remove from hose barb.

4. Unscrew nozzle body and hose barb from nozzle adapter and solenoid assembly. Remove strainer.

Note: Use a back up wrench on the nozzle adapter while unscrewing the nozzle body to avoid unnecessary torque on the solenoid assembly.

5. Inspect and clean strainer. Replace if necessary.

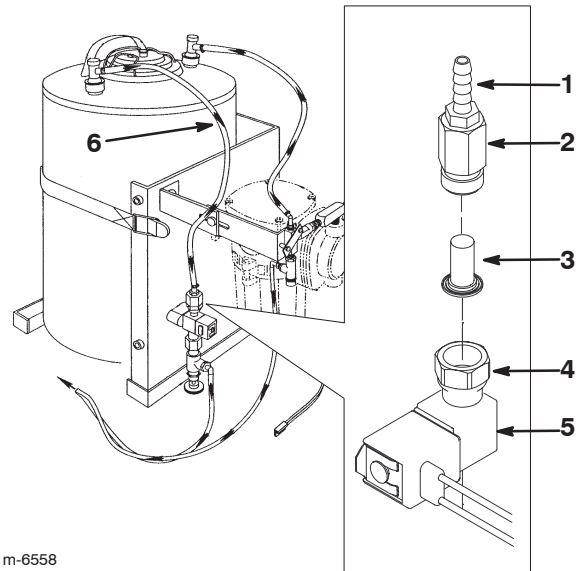

m-6558

Figure 38

1. Hose barb
2. Nozzle body
3. Strainer
4. Nozzle adapter
5. Solenoid assembly
6. Liquid hose

6. Assemble strainer and nozzle body/hose barb as shown in Figure 38 and install into nozzle adapter/solenoid assembly.
7. Attach liquid hose to hose barb and un-clamp.
8. Flip pressure release valve to the down position.

If the problem persists, please contact your local Authorized Toro Distributor.

Storage

1. Remove the couplers on top of the tank.
2. Loosen and unhook the foam marker tank strap.
3. Remove the tank from the bracket, remove the tank lid, and empty the contents of the tank.
4. Rinse and flush the inside of the tank.
5. Install the lid on the tank.
6. Attach the couplers.
7. Strap the tank into place.

