



Count on it.

Operator's Manual

**TimeCutter® Z380 and Z420
Riding Mowers**

Model No. 74402—Serial No. 250000001 and Up

Model No. 74403—Serial No. 250000001 and Up

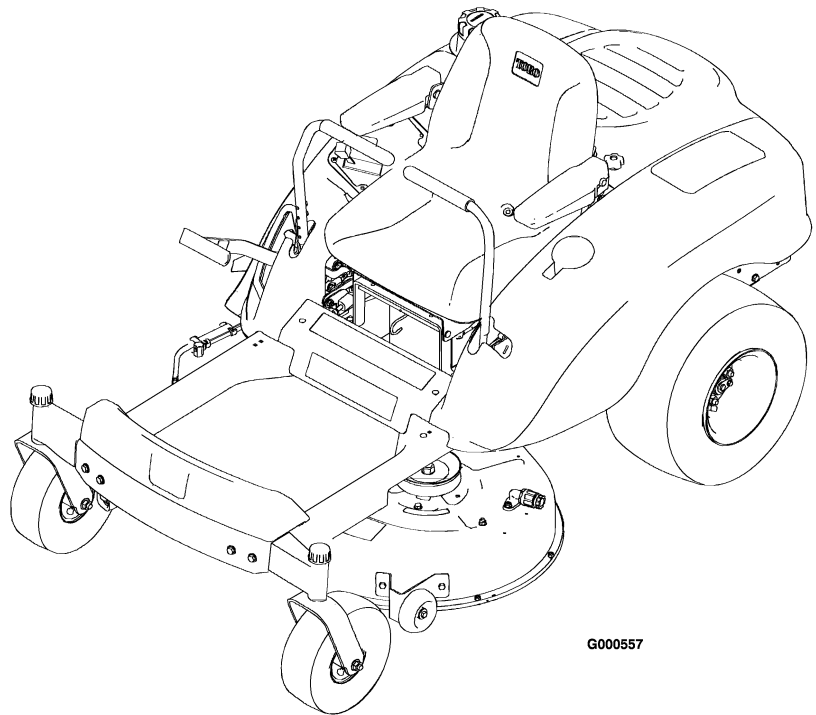

G000557

This spark ignition system complies with Canadian ICES-002

Contents

- Introduction 2
- Safety 4
 - Safe Operation Practices for Ride-on (riding) Rotary Lawnmower Machines 4
 - Safe Operating Practices 4
 - Toro Riding Mower Safety 5
 - Sound Pressure for Model 74402 6
 - Sound Power for Model 74402 6
 - Vibration for Model 74402 6
 - Sound Pressure for Model 74403 6
 - Sound Power for Model 74403 6
 - Vibration for Model 74403 6
 - Slope Chart 7
 - Safety and Instructional Decals 8
- Product Overview 11
 - Controls 11
- Operation 13
 - Think Safety First 13
 - Recommended Gasoline 13
 - Checking the Engine Oil Level 14
 - Starting and Stopping the Engine 14
 - Operating the Power Take Off (PTO) 15
 - The Safety Interlock System 15
 - Driving Forward or Backward 16
 - Stopping the Machine 16
 - Adjusting the Height of Cut 17
 - Positioning the Seat 17
 - Adjusting the Motion Control Levers 17
 - Pushing the Machine by Hand 18
 - Adjusting the Footrest 18
 - Side Discharge 18
 - Operating Tips 19
- Maintenance 21
 - Recommended Maintenance Schedule(s) 21
 - Premaintenance Procedures 21
 - Removing and Installing the Engine Hood 21
 - Lubrication 22
 - Greasing the Bearings 22
 - Engine Maintenance 22
 - Servicing the Air Cleaner 22
 - Servicing the Engine Oil 23
 - Fuel System Maintenance 25
 - Draining the Fuel Tank 25
 - Replacing the Fuel Filter 26
 - Electrical System Maintenance 26

- Servicing the Spark Plug 26
- Servicing the Battery 27
- Servicing the Fuses 28
- Drive System Maintenance 29
 - Checking the Tire Pressure 29
- Mower Maintenance 29
 - Servicing the Cutting Blades 29
 - Leveling the Mower from Side-to-Side 31
 - Adjusting the Front-to-Rear Blade Slope 32
 - Removing the Mower 33
 - Mower Belt Maintenance 33
 - Installing the Mower 34
 - Replacing the Grass Deflector 34
- Cleaning 35
 - Washing the Underside of the Mower 35
- Storage 37
 - Cleaning and Storage 37
- Troubleshooting 38
- Schematics 41

Introduction

Read this information carefully to learn how to operate and maintain your product properly and to avoid injury and product damage. You are responsible for operating the product properly and safely.

You may contact Toro directly at www.Toro.com for product and accessory information, help finding a dealer, or to register your product.

Whenever you need service, genuine Toro parts, or additional information, contact an Authorized Service Dealer or Toro Customer Service and have the model and serial numbers of your product ready. Figure 1 identifies the location of the model and serial numbers on the product. Write the numbers in the space provided.

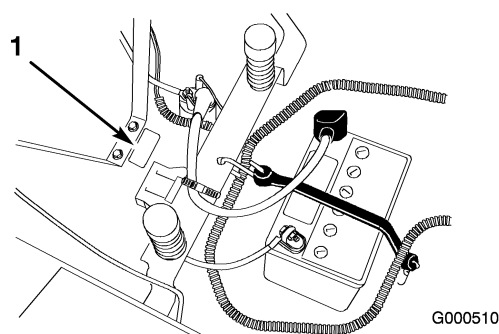

Figure 1

- 1. Model and serial number plate

Write the product model and serial numbers in the space below:

Model No. _____
Serial No. _____

This manual identifies potential hazards and has safety messages identified by the safety alert symbol (Figure 2), which signals a hazard that may cause serious injury or death if you do not follow the recommended precautions.



Figure 2

1. Safety alert symbol.
-

This manual uses two other words to highlight information. **Important** calls attention to special mechanical information and **Note** emphasizes general information worthy of special attention.

Safety

Safe Operation Practices for Ride-on (riding) Rotary Lawnmower Machines

This machine meets or exceeds European Standards in effect at the time of production. However, improper use or maintenance by the operator or owner can result in injury. To reduce the potential for injury, comply with these safety instructions and always pay attention to the safety alert symbol, which means CAUTION, WARNING, or DANGER -“personal safety instruction.” Failure to comply with the instruction may result in personal injury or death.

Safe Operating Practices

The following instructions are from the CEN standard EN 836:1997.

This product is capable of amputating hands and feet and throwing objects. Always follow all safety instructions to avoid serious injury or death.

Training

- Read the instructions carefully. Be familiar with the controls and the proper use of the equipment.
- Never allow children or people unfamiliar with these instructions to use the lawnmower. Local regulations can restrict the age of the operator.
- Never mow while people, especially children, or pets are nearby.
- Keep in mind that the operator or user is responsible for accidents or hazards occurring to other people or their property.
- Do not carry passengers.
- All drivers should seek and obtain professional and practical instruction. Such instruction should emphasize:
 - the need for care and concentration when working with ride-on machines;
 - control of a ride-on machine sliding on a slope will not be regained by the application of the brake. The main reasons for loss of control are:
 - ◇ insufficient wheel grip;
 - ◇ being driven too fast;
 - ◇ inadequate braking;
 - ◇ the type of machine is unsuitable for its task;
 - ◇ lack of awareness of the effect of ground conditions, especially slopes;

◇ incorrect hitching and load distribution.

Preparation

- While mowing, always wear substantial footwear and long trousers. Do not operate the equipment when barefoot or wearing open sandals.
- Thoroughly inspect the area where the equipment is to be used and remove all objects which may be thrown by the machine.
- Warning-Fuel is highly flammable.
 - Store fuel in containers specifically designed for this purpose.
 - Refuel outdoors only and do not smoke while refuelling.
 - Add fuel before starting the engine. Never remove the cap of the fuel tank or add fuel while the engine is running or when the engine is hot.
 - If fuel is spilled, do not attempt to start the engine but move the machine away from the area of spillage and avoid creating any source of ignition until fuel vapors have dissipated.
 - Replace all fuel tanks and container caps securely.
- Replace faulty silencers.
- Before using, always visually inspect to see that the blades, blade bolts and cutter assembly are not worn or damaged. Replace worn or damaged blades and bolts in sets to preserve balance.
- On multi-bladed machines, take care as rotating one blade can cause other blades to rotate.

Operation

- Be alert, slow down and use caution when making turns. Look behind and to the side before changing directions.
- Do not operate the engine in a confined space where dangerous carbon monoxide fumes can collect.
- Mow only in daylight or in good artificial light.
- Before attempting to start the engine, disengage all blade attachment clutches and shift into neutral.
- Do not use on slopes of more than 12-1/2 degrees.
- Remember there is no such thing as a safe slope. Travel on grass slopes requires particular care. To guard against overturning:
 - do not stop or start suddenly when going up or downhill;
 - use low speeds on slopes and during tight turns;

- stay alert for humps and hollows and other hidden hazards;
- Use care when pulling loads.
 - Use only approved drawbar hitch points.
 - Limit loads to those you can safely control.
 - Do not turn sharply. Use care when reversing.
- Watch out for traffic when crossing or near roadways.
- Stop the blades rotating before crossing surfaces other than grass.
- When using any attachments, never direct discharge of material toward bystanders nor allow anyone near the machine while in operation.
- Never operate the machine with damaged guards or without safety protective devices in place.
- Do not change the engine governor settings or overspeed the engine. Operating the engine at excessive speed can increase the hazard of personal injury.
- Before leaving the operator's position:
 - disengage the power take-off and lower the attachments;
 - change into neutral and set the parking brake;
 - stop the engine and remove the key.
- Disengage drive to attachments, stop the engine, and disconnect the spark plug wire(s) or remove the ignition key
 - before clearing blockages or unclogging chute;
 - before checking, cleaning or working on the lawnmower;
 - after striking a foreign object. Inspect the lawnmower for damage and make repairs before restarting and operating the equipment;
 - if the machine starts to vibrate abnormally (check immediately).
- Disengage drive to attachments when transporting or not in use.
- Stop the engine and disengage drive to attachment
 - before refuelling;
 - before removing the grass catcher;
 - before making height adjustment unless adjustment can be made from the operator's position.
- Reduce the throttle setting during engine run-out and, if the engine is provided with a shut-off valve, turn the fuel off at the conclusion of mowing.

Maintenance and Storage

- Keep all nuts, bolts and screws tight to be sure the equipment is in safe working condition.

- Never store the equipment with fuel in the tank inside a building where fumes can reach an open flame or spark.
- Allow the engine to cool before storing in any enclosure.
- To reduce the fire hazard, keep the engine, silencer, battery compartment and fuel storage area free of grass, leaves, or excessive grease.
- Check the grass catcher frequently for wear or deterioration.
- Replace worn or damaged parts for safety.
- If the fuel tank has to be drained, this should be done outdoors.
- When machine is to be parked, stored or left unattended, lower the cutting means.

Toro Riding Mower Safety

The following list contains safety information specific to Toro products or other safety information that you must know that is not included in the CEN standard.

- Engine exhaust contains carbon monoxide, which is an odorless, deadly poison that can kill you. Do not run engine indoors or in an enclosed area.
- Keep hands, feet, hair and loose clothing away from attachment discharge area, underside of mower and any moving parts while engine is running.
- Do not touch equipment or attachment parts which may be hot from operation. Allow to cool before attempting to maintain, adjust, or service.
- Battery acid is poisonous and can cause burns. Avoid contact with skin, eyes and clothing. Protect your face, eyes, and clothing when working with a battery.
- Battery gases can explode. Keep cigarettes, sparks, and flames away from battery.
- Use only genuine Toro replacement parts to ensure that original standards are maintained.
- Use only Toro-approved attachments.

Slope Operation

- Do not mow slopes greater than 12-1/2 degrees.
- Do not mow near drop-offs, ditches, steep banks, or water. Wheels dropping over edges can cause rollovers, which may result in serious injury, death, or drowning.
- Do not mow slopes when grass is wet. Slippery conditions reduce traction and could cause sliding and loss of control.
- Do not make sudden turns or rapid speed changes.

- Use a walk behind mower and/or a hand trimmer near drop-offs, ditches, steep banks, or water.
- Reduce speed and use extreme caution on slopes.
- Remove or mark obstacles such as rocks, tree limbs, etc. from mowing area. Tall grass can hide obstacles.
- Watch for ditches, holes, rocks dips, and rises that change the operating angle, as rough terrain could overturn the machine.
- Avoid sudden starts when mowing uphill because the mower may tip backwards.
- Be aware that loss of traction may occur going downhill. Weight transfer to the front wheels may cause drive wheels to slip and cause loss of braking and steering.
- Always avoid sudden starting or stopping on a slope. If tires lose traction, disengage the blades and proceed slowly off the slope.
- Follow the manufacturer's recommendations for wheel weights or counterweights to improve stability.
- Use extreme care with grass catchers or other attachments. These can change the stability of the machine and cause loss of control.

Sound Pressure for Model 74402

This unit has a maximum sound pressure level at the operator's ear of 86 dBA, based on measurements of identical machines per Directive 98/37/EC.

Sound Power for Model 74402

This unit has a guaranteed sound power level of 100 dBA, based on measurements of identical machines per Directive 2000/14/EC.

Vibration for Model 74402

This unit does not exceed a hand/arm vibration level of 3.22 m/s², based on measurements of identical machines per Directive 98/37/EC.

This unit does not exceed a whole body vibration level of .195 m/s², based on measurements of identical machines per Directive 98/37/EC.

Sound Pressure for Model 74403

This unit has a maximum sound pressure level at the operator's ear of 87 dBA, based on measurements of identical machines per Directive 98/37/EC.

Sound Power for Model 74403

This unit has a guaranteed sound power level of 100 dBA, based on measurements of identical machines per Directive 2000/14/EC.

Vibration for Model 74403

This unit does not exceed a hand/arm vibration level of 4.66 m/s², based on measurements of identical machines per Directive 98/37/EC.

This unit does not exceed a whole body vibration level of .14 m/s², based on measurements of identical machines per Directive 98/37/EC.

Slope Chart

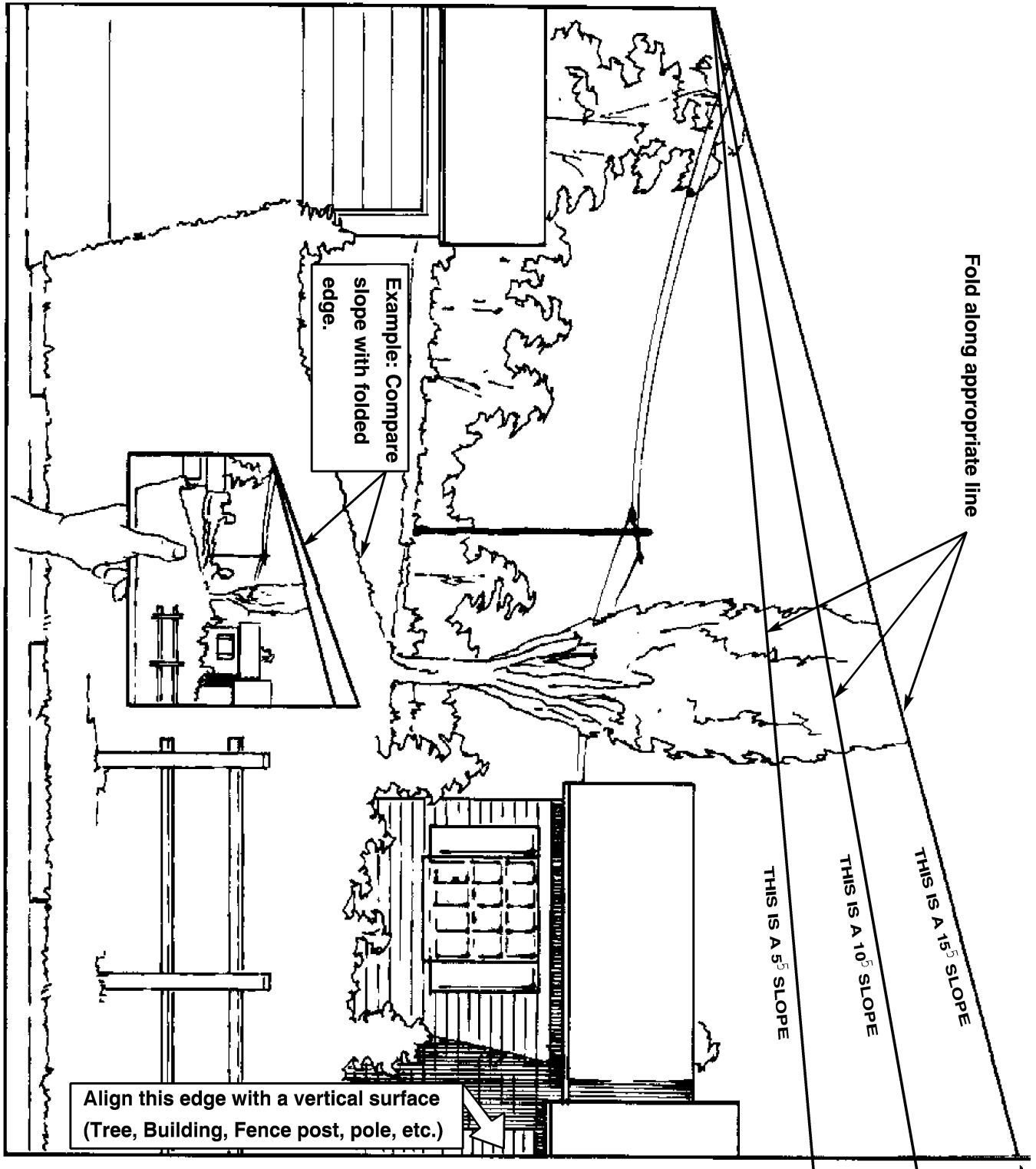

Safety and Instructional Decals



Safety decals and instructions are easily visible to the operator and are located near any area of potential danger. Replace any decal that is damaged or lost.

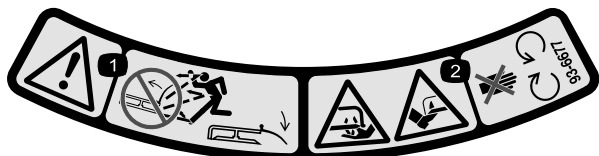

93-6677

1. Warning—don't operate the mower with the deflector up or removed; keep the deflector in place.
2. Cutting/dismemberment hazard of hand or foot, mower blade—stay away from moving parts.



93-7009

1. Warning—don't operate the mower with the deflector up or removed; keep the deflector in place.
2. Cutting/dismemberment hazard of hand or foot, mower blade—stay away from moving parts.



93-7010

1. Thrown object hazard—keep bystanders a safe distance from the machine.
2. Thrown object hazard, mower—keep the deflector in place.
3. Cutting/dismemberment of hand or foot—stay away from moving parts.

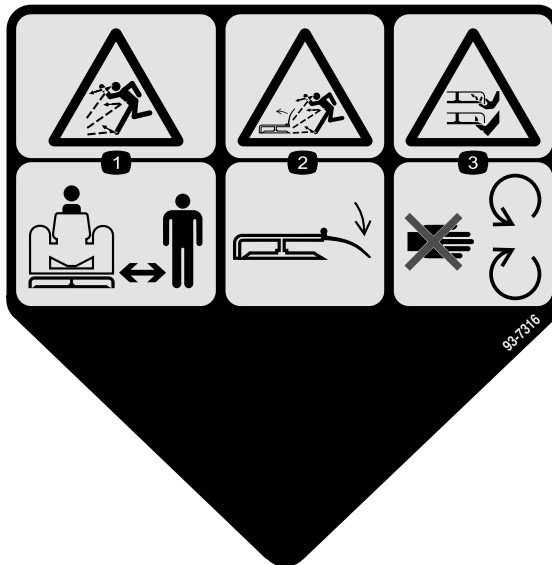

93-7316

1. Thrown object hazard—keep bystanders a safe distance from the machine.
2. Thrown object hazard, mower—keep the deflector in place.
3. Cutting/dismemberment of hand or foot—stay away from moving parts.

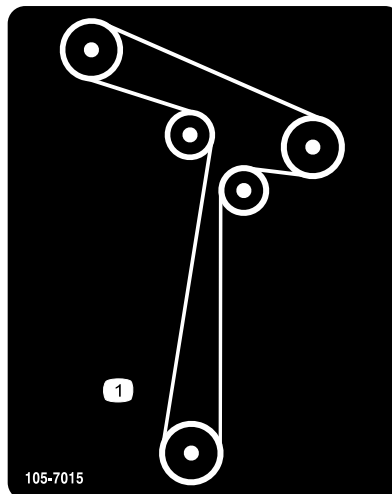

105-7015



106-2223

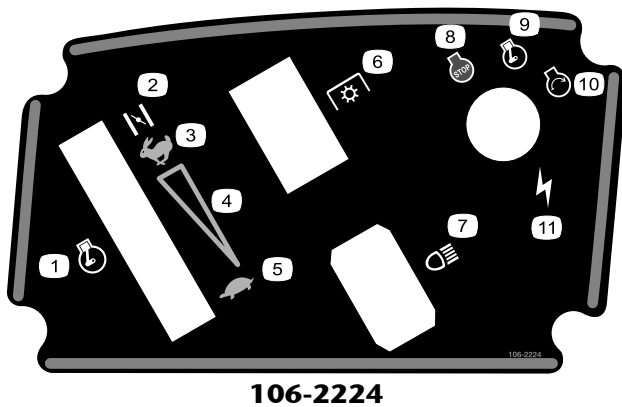

106-2224

- | | |
|--------------------------------|------------------|
| 1. Throttle | 7. Headlights |
| 2. Choke | 8. Engine—stop |
| 3. Fast | 9. Engine—run |
| 4. Continuous variable setting | 10. Engine—start |
| 5. Slow | 11. Ignition |
| 6. Power take-off (PTO) | |

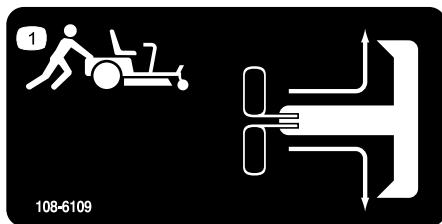

108-6109

1. To push the machine, move tow levers forward and then out to lock them into position.

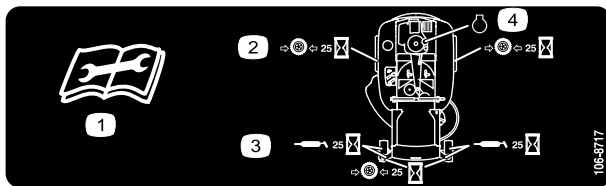

106-8717

1. Read the instructions before servicing or performing maintenance.
2. Check tire pressure every 25 operating hours.
3. Grease every 25 operating hours.
4. Engine

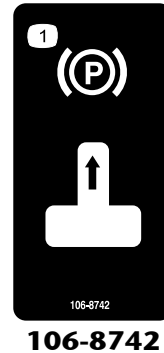

106-8742

1. Parking brake

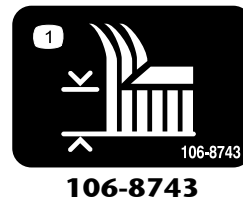

106-8743

1. Height of cut



Battery Symbols

Some or all of these symbols are on your battery

- | | |
|--|--|
| 1. Explosion hazard | 6. Keep bystanders a safe distance from the battery. |
| 2. No fire, open flame, or smoking. | 7. Wear eye protection; explosive gases can cause blindness and other injuries |
| 3. Caustic liquid/chemical burn hazard | 8. Battery acid can cause blindness or severe burns. |
| 4. Wear eye protection | 9. Flush eyes immediately with water and get medical help fast. |
| 5. Read the <i>Operator's Manual</i> . | 10. Contains lead; do not discard. |

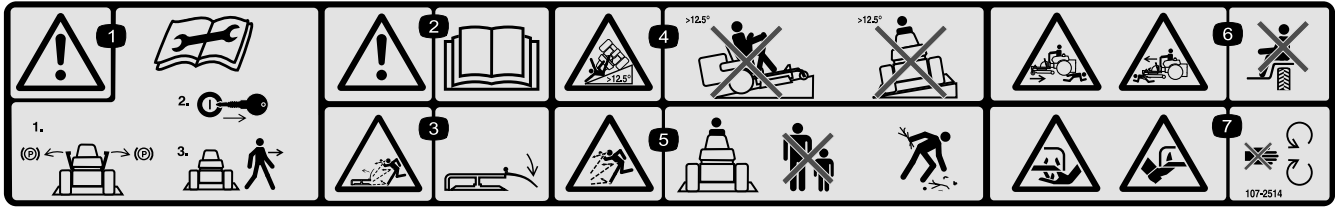

107-2514

1. Warning—read the instructions before servicing or performing maintenance; move the levers out to set the parking brake and remove the ignition key before leaving the machine.
2. Warning—read the *Operator's Manual*.
3. Thrown object hazard, mower—keep the deflector in place.
4. Tipping hazard, slopes greater than 12.5 degrees—do not drive the machine on a slope greater than 12.5 degrees.
5. Thrown object hazard—keep bystanders a safe distance from the machine and pick up debris before operating.
6. Crushing/dismemberment hazard of bystanders—do not carry passengers.
7. Cutting/dismemberment hazard of hand or foot, mower blade—stay away from moving parts.

Product Overview

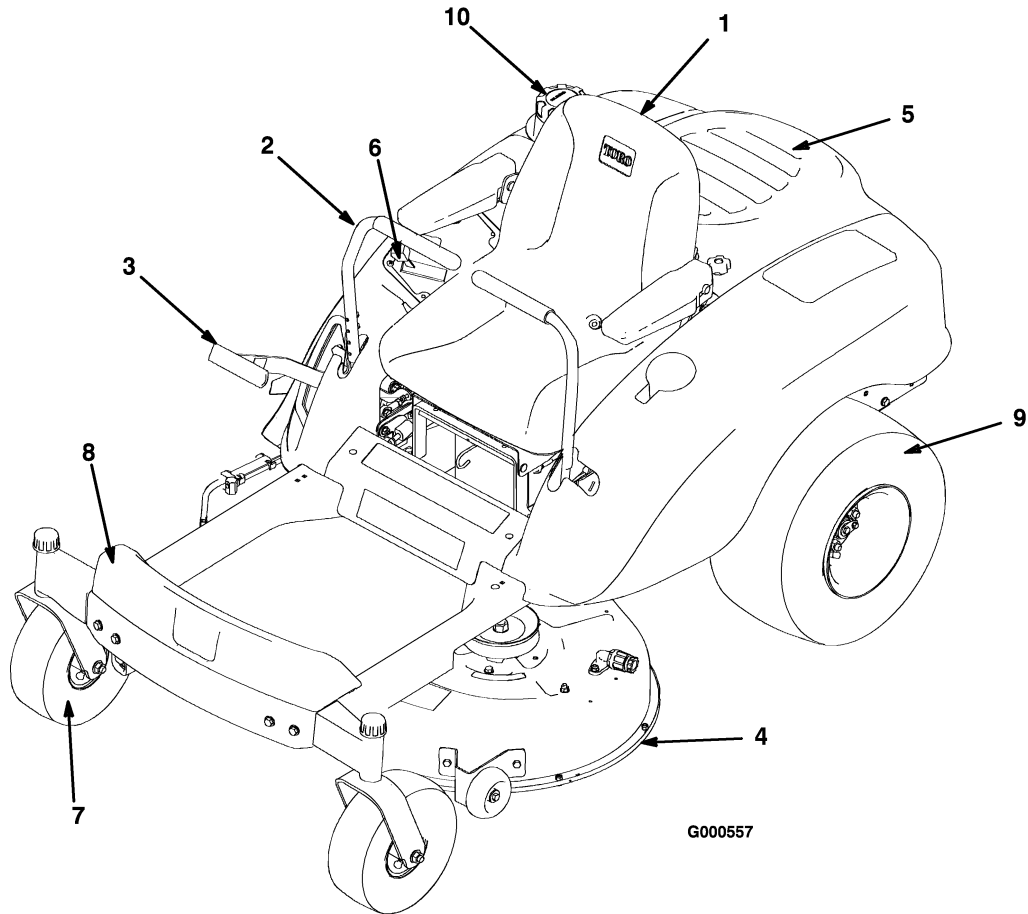

Figure 3

- | | | | |
|------------------------|------------------|-----------------------|------------------|
| 1. Seat | 4. Mower deck | 7. Front caster wheel | 10. Gas tank cap |
| 2. Control levers | 5. Engine hood | 8. Footrest | |
| 3. Height of cut lever | 6. Control panel | 9. Rear drive wheel | |

Controls

Become familiar with all of the controls Figure 4 and Figure 5 before you start the engine and operate the machine.

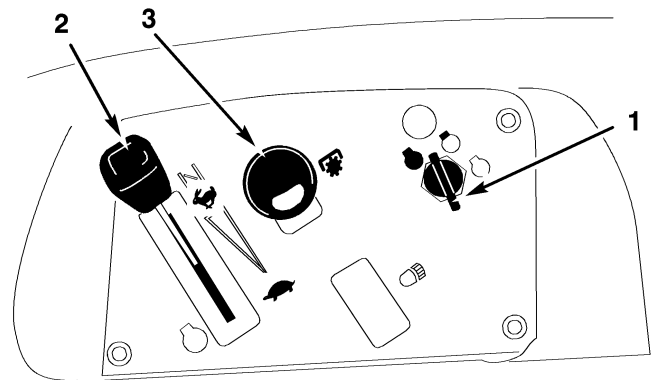

Figure 4

- | | |
|--------------------|-------------------------|
| 1. Ignition switch | 3. Power take off (PTO) |
| 2. Throttle/Choke | |

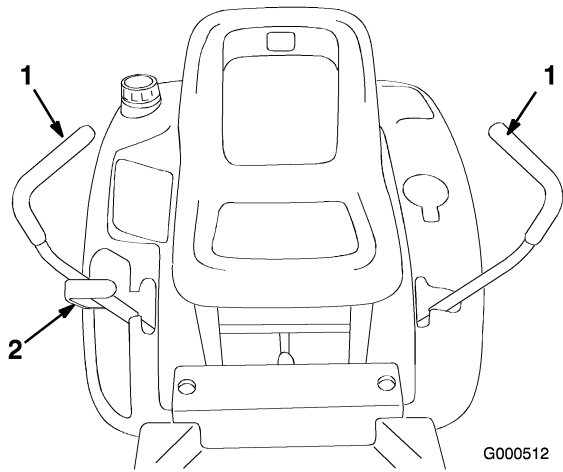

Figure 5

1. Motion control lever 2. Height-of-cut lever
-

Parking Brake

The parking brake is automatically set when the motion control levers are in the brake position .

Always position the motion control levers into the brake position when you stop the machine or leave it unattended.

Operation

Note: Determine the left and right sides of the machine from the normal operating position.

Think Safety First

Please carefully read all of the safety instructions and decals in the safety section. Knowing this information could help you, your family, pets or bystanders avoid injury.



Mowing on wet grass or steep slopes can cause sliding and loss of control.

Wheels dropping over edges can cause rollovers, which may result in serious injury, death or drowning.

To avoid loss of control and possibility of rollover:

- Do not mow near drop-offs or near water.
- Do not mow slopes greater than 12.5 degrees.
- Reduce speed and use extreme caution on slopes.
- Avoid sudden turns or rapid speed changes.

Recommended Gasoline

Use UNLEADED Regular Gasoline suitable for automotive use (87 pump octane minimum). Leaded regular gasoline may be used if unleaded regular is not available.

Important: Never use methanol, gasoline containing methanol, or gasohol containing more than 10% ethanol because the fuel system could be damaged. Do not mix oil with gasoline.



Gasoline is harmful or fatal if swallowed. Long-term exposure to vapors can cause serious injury and illness.

- Avoid prolonged breathing of vapors.
- Keep face away from nozzle and gas tank or conditioner opening.
- Keep gas away from eyes and skin.

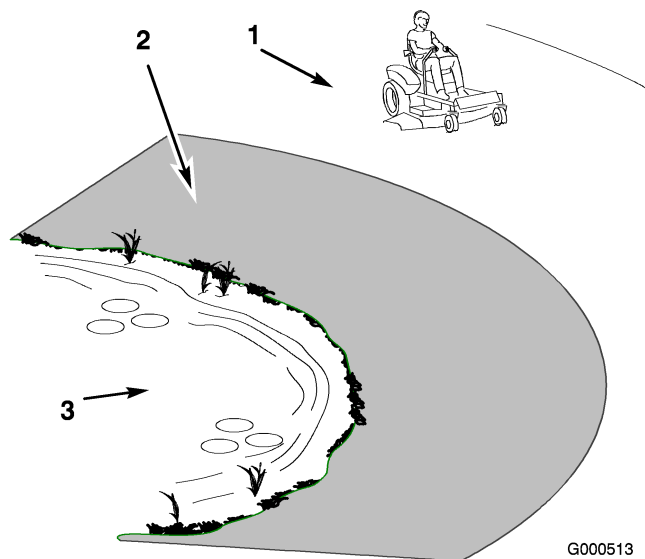

Figure 6

1. Safe Zone-use the TimeCutter here
2. Use walk behind mower and/or hand trimmer near drop-offs and water.
3. Water



In certain conditions, gasoline is extremely flammable and highly explosive. A fire or explosion from gasoline can burn you and others and can damage property.

- Fill the fuel tank outdoors, in an open area, when the engine is cold. Wipe up any gasoline that spills.
- Never fill the fuel tank inside an enclosed trailer.
- Do not fill the fuel tank completely full. Add gasoline to the fuel tank until the level is 1/4 to 1/2 inch (6 to 13 mm) below the bottom of the filler neck. This empty space in the tank allows gasoline to expand.
- Never smoke when handling gasoline, and stay away from an open flame or where gasoline fumes may be ignited by a spark.
- Store gasoline in an approved container and keep it out of the reach of children. Never buy more than a 30-day supply of gasoline.
- Always place gasoline containers on the ground away from your vehicle before filling.
- Do not fill gasoline containers inside a vehicle or on a truck or trailer bed because interior carpets or plastic truck bed liners may insulate the container and slow the loss of any static charge.
- When practical, remove gas-powered equipment from the truck or trailer and refuel the equipment with its wheels on the ground.
- If this is not possible, then refuel such equipment on a truck or trailer from a portable container, rather than from a gasoline dispenser nozzle.
- If a gasoline dispenser nozzle must be used, keep the nozzle in contact with the rim of the fuel tank or container opening at all times until fueling is complete.

Using Stabilizer/Conditioner

Use a fuel stabilizer/conditioner in the machine to provide the following benefits:

- Keeps gasoline fresh during storage of 90 days or less. For longer storage it is recommended that the fuel tank be drained.

- Cleans the engine while it runs
- Eliminates gum-like varnish buildup in the fuel system, which causes hard starting

Important: Do not use fuel additives containing methanol or ethanol.

Add the correct amount of gas stabilizer/conditioner to the gas.

Note: A fuel stabilizer/conditioner is most effective when mixed with fresh gasoline. To minimize the chance of varnish deposits in the fuel system, use fuel stabilizer at all times.

Filling the Fuel Tank

1. Shut the engine off and set the parking brake.
2. Clean around the fuel tank cap and remove the cap. Add unleaded regular gasoline to the fuel tank until the level is 1/4 to 1/2 inch (6 to 13 mm) below the bottom of the filler neck. This space in the tank allows gasoline to expand. Do not fill the fuel tank completely full.
3. Install the fuel tank cap securely. Wipe up any gasoline that may have spilled.

Checking the Engine Oil Level

Before you start the engine and use the machine, check the oil level in the engine crankcase; refer to Checking the Oil Level in Engine Maintenance, page 22.

Starting and Stopping the Engine

Starting the Engine

1. Sit down on the seat and move the motion controls to the brake position.
2. Move the PTO (power take-off) to Off (Figure 7).

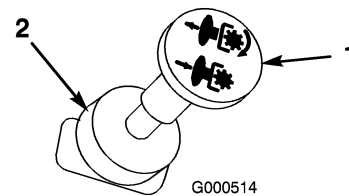

Figure 7

1. PTO-On

2. PTO-Off

3. Move the throttle lever to Choke before starting a cold engine (Figure 8).

Note: A warm or hot engine may not require choking.

- Turn the ignition key to Start to energize the starter. When the engine starts, release the key.

Important: Do not engage the starter for more than 10 seconds at a time. If the engine fails to start, allow a 60 second cool-down period between attempts. Failure to follow these instructions can burn out the starter motor.

- After the engine starts, move the throttle lever to Fast (Figure 8). If the engine stalls or hesitates, move the throttle lever back to Choke for a few seconds. Then move the throttle lever to the desired setting. Repeat this as required.

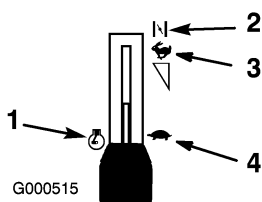

Figure 8

- | | |
|-----------|---------|
| 1. Engine | 3. Fast |
| 2. Choke | 4. Slow |

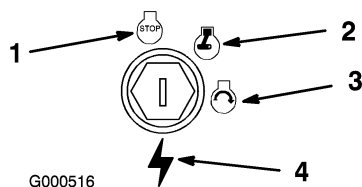

Figure 9

- | | |
|--------|-------------|
| 1. Off | 3. Start |
| 2. Run | 4. Ignition |

Stopping the Engine

- Move the throttle lever to Fast (Figure 8).
- Move the PTO to Off (Figure 7).
- Turn the ignition key to Off (Figure 9).
- Pull the wire off of the spark plug(s) to prevent the possibility of someone accidentally starting the machine before transporting or storing the machine.
- Close the fuel shut-off valve under the front of the fuel tank before transporting or storing the machine.

Important: Make sure the fuel shut-off valve is closed before transporting or storing the machine, as fuel leakage may occur.

Operating the Power Take Off (PTO)

The power take off (PTO) switch engages and disengages power to the electric clutch.

Engaging the PTO

- Release pressure on the traction control levers and place the machine in neutral.
- Move the throttle to the Fast position.
- Pull out on the PTO switch to engage it (Figure 10).

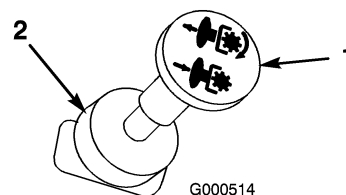

Figure 10

- | | |
|-----------|------------|
| 1. PTO-On | 2. PTO-Off |
|-----------|------------|

Disengaging the PTO

Push the PTO switch to Off (Figure 10).

The Safety Interlock System



If safety interlock switches are disconnected or damaged the machine could operate unexpectedly causing personal injury.

- Do not tamper with the interlock switches.
- Check the operation of the interlock switches daily and replace any damaged switches before operating the machine.

Understanding the Safety Interlock System

The safety interlock system is designed to prevent the engine from starting unless:

The PTO is disengaged.

The motion control levers are in the brake position.

The safety interlock system also is designed to stop the engine when the control levers are out of the brake position and you rise from the seat when the PTO is engaged.

Testing the Safety Interlock System

Test the safety interlock system before you use the machine each time. If the safety system does not

operate as described below, have an Authorized Service Dealer repair the safety system immediately.

1. While sitting on the seat, with the control levers in brake position, and move the PTO to On. Try starting the engine; the engine should not crank.
2. While sitting on the seat, move the PTO to Off. Move either motion control lever to the center, unlocked position. Try starting the engine; the engine should not crank. Repeat with the other motion control lever.
3. While sitting on the seat, move the PTO to Off, and lock the motion control levers in neutral. Start the engine. While the engine is running, move the motion control levers to the center, unlocked position, engage the PTO, and rise slightly from the seat; the engine should stop.

Driving Forward or Backward

The throttle control regulates the engine speed as measured in rpm (revolutions per minute). Place the throttle control in the Fast position for best performance. Always operate in the full throttle position.



The machine can spin very rapidly. The operator may lose control of the machine and cause personal injury or damage to the machine.

- Use caution when making turns.
- Slow the machine down before making sharp turns.

Forward

1. Move the levers to the center, unlocked position.
2. To go forward, slowly push the motion control levers forward (Figure 11).

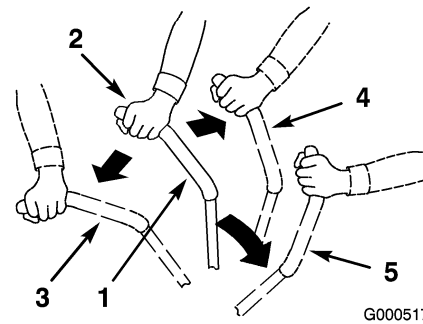

Figure 11

- | | |
|---------------------------|-------------------|
| 1. Motion control lever | 4. Backward |
| 2. Center unlock position | 5. Brake position |
| 3. Forward | |

To go straight, apply equal pressure to both motion control levers (Figure 11).

To turn, release pressure on the motion control lever toward the direction you want to turn (Figure 11).

The farther you move the traction control levers in either direction, the faster the machine will move in that direction.

To stop, pull the motion control levers to neutral.

Backward

1. Move the levers to the center, unlocked position.
2. To go backward, slowly pull the motion control levers rearward (Figure 11).

To go straight, apply equal pressure to both motion control levers (Figure 11).

To turn, release the pressure on the motion control lever toward the direction you want to turn (Figure 11).

To stop, push the motion control levers to neutral.

Stopping the Machine

To stop the machine, move the traction control levers to neutral and separate to the brake position, disengage the PTO, ensure the throttle is in the fast position, and turn the ignition key to off. Remember to remove the key from the ignition switch.



Children or bystanders may be injured if they move or attempt to operate the mower while it is unattended.

Always remove the ignition key and move the motion control levers to the brake position when leaving the machine unattended, even if just for a few minutes.

Adjusting the Height of Cut

The height of cut is adjusted from 1-1/2 to 4-1/2 inch (38 to 114 mm) in 1/2 inch (13 mm) increments by moving the height-of-cut lever in different locations.

1. Raise the height-of-cut lever to the transport position (also the 4-1/2 inch (114 mm) cutting height position (Figure 12).
2. To adjust, pull up on the height-of-cut lever and move it to the desired position (Figure 12).

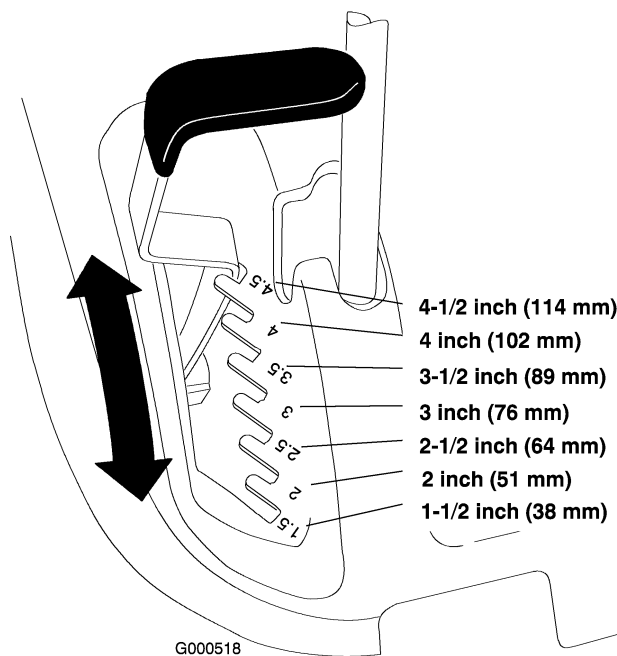

Figure 12

1. Height-of-cut lever
2. Height-of-cut positions

Positioning the Seat

The seat can move forward and backward. Position the seat where you have the best control of the machine and are most comfortable.

1. Raise the seat and loosen the adjustment knobs enough to move the seat (Figure 13).

Important: Make sure that the spacers stay in place when loosening the knobs to move the seat. Loss of the spacers can result in damage to the seat.

2. Move the seat to the desired position and tighten the knobs.

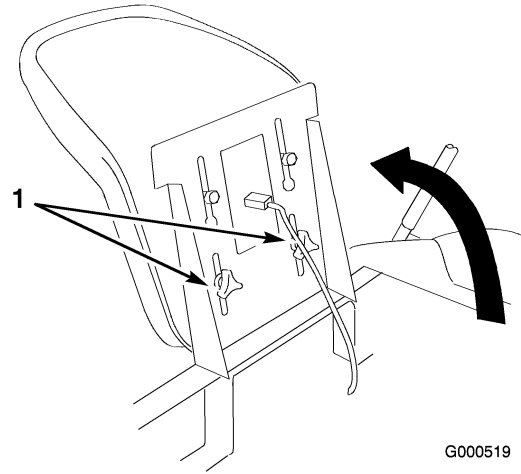

Figure 13

1. Adjustment knobs

Adjusting the Motion Control Levers

The motion control levers can be adjusted higher or lower for maximum operator comfort.

1. Remove the 2 bolts holding the control lever to the control arm shaft (Figure 14).
2. Move the control lever to the next set of holes. Secure the lever with the 2 bolts (Figure 14).

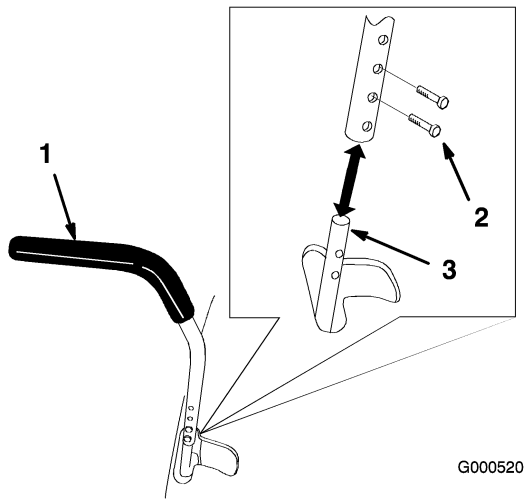

Figure 14

1. Control lever
2. Bolt
3. Control arm shaft

3. Repeat the adjustment for the opposite control lever.

Pushing the Machine by Hand

Important: Always push the machine by hand. Never tow the machine because damage may occur.

To Push the Machine

1. Park the machine on a level surface and disengage the blade control (PTO).
2. Move the motion control levers outward to engage the parking brake, stop the engine, remove the key, and wait for all moving parts to stop before leaving the operating position.
3. Raise the seat to access the bypass levers (Figure 15).
4. Move the two bypass levers forward and then outward to lock them in place as shown in Figure 15.
5. Move the motion control levers inward to disengage the parking brake.

The machine is now able to be pushed by hand.

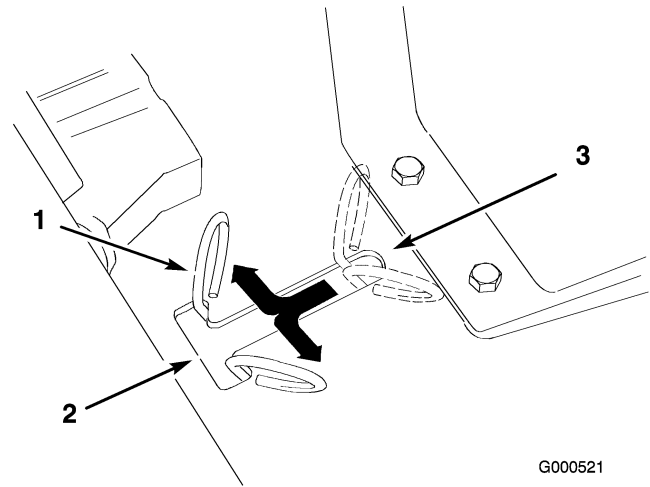

Figure 15

1. Bypass levers
2. Lever position for pushing the machine
3. Lever position for operating the machine

To Operate the Machine

Move the bypass levers to the inside and pull them rearward, to the end the slot (Figure 15).

Note: The machine will not drive unless the bypass levers are disengaged.

Adjusting the Footrest

The footrest can be adjusted forward or backward for maximum operator comfort.

Lift up the footrest and place the rods in the same hole positions (Figure 16).

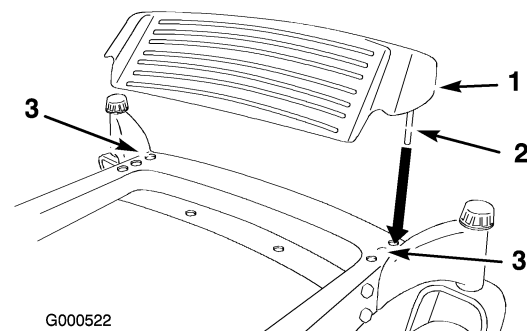

Figure 16

1. Footrest
2. Rod
3. Hole positions

Side Discharge

The mower has a hinged grass deflector that disperses clippings to the side and down toward the turf.



Without the grass deflector, discharge cover, or complete grass catcher assembly mounted in place, you and others are exposed to blade contact and thrown debris. Contact with rotating mower blade(s) and thrown debris will cause injury or death.

- Never remove the grass deflector from the mower because the grass deflector routes material down toward the turf. If the grass deflector is ever damaged, replace it immediately.
- Never put your hands or feet under the mower.
- Never try to clear discharge area or mower blades unless you move the PTO to Off and rotate the ignition key to Off. Also remove the key and pull the wire off the spark plug(s).

Operating Tips

Fast Throttle Setting

For best mowing and maximum air circulation, operate the engine at the Fast position. Air is required to thoroughly cut grass clippings, so do not set the height-of-cut so low as to totally surround the mower by uncut grass. Always try to have one side of the mower free from uncut grass, which allows air to be drawn into the mower.

Cutting a Lawn for the First Time

Cut grass slightly longer than normal to ensure that the cutting height of the mower does not scalp any uneven ground. However, the cutting height used in the past is generally the best one to use. When cutting grass longer than six inches tall, you may want to cut the lawn twice to ensure an acceptable quality of cut.

Cut 1/3 of the Grass Blade

It is best to cut only about 1/3 of the grass blade. Cutting more than that is not recommended unless grass is sparse, or it is late fall when grass grows more slowly.

Mowing Direction

Alternate mowing direction to keep the grass standing straight. This also helps disperse clippings which enhances decomposition and fertilization.

Mow at Correct Intervals

Normally, mow every four days. But remember, grass grows at different rates at different times. So to maintain the same cutting height, which is a good practice, mow more often in early spring. As the grass growth rate slows in mid summer, mow less frequently. If you cannot mow for an extended period, first mow at a high cutting height; then mow again two days later at a lower height setting.

Cutting Speed

To improve cut quality, use a slower ground speed.

Avoid Cutting Too Low

If the cutting width of the mower is wider than the mower you previously used, raise the cutting height to ensure that uneven turf is not cut too short.

Long Grass

If the grass is ever allowed to grow slightly longer than normal, or if it contains a high degree of moisture, raise the cutting height higher than usual and cut the grass at this setting. Then cut the grass again using the lower, normal setting.

When Stopping

If the machine's forward motion must be stopped while mowing, a clump of grass clippings may drop onto your lawn. To avoid this, move onto a previously cut area with the blades engaged.

Keep the Underside of the Mower Clean

Clean clippings and dirt from the underside of the mower after each use. If grass and dirt build up inside the mower, cutting quality will eventually become unsatisfactory.

Blade Maintenance

Maintain a sharp blade throughout the cutting season because a sharp blade cuts cleanly without tearing or shredding the grass blades. Tearing and shredding turns grass brown at the edges, which slows growth and increases the chance of disease. Check the cutter blades daily for sharpness, and for any wear or damage. File down any nicks and sharpen the blades as necessary. If a blade is damaged or worn, replace it immediately with a genuine Toro replacement blade.

Safe Towing Practices

Tow only with a machine that has a hitch designed for towing. Do not attach towed equipment except at the hitch point. This product has a limited towing capacity for small attachments, such as leaf sweepers, rollers up to 500 lbs (227 kg) or carts up to 5 cubic feet. These types of attachments should be limited to flat ground. Never allow children or others in or on towed equipment. On slopes, the weight of towed equipment may cause a loss of traction and control. Travel slowly and allow extra distance to stop.

Maintenance

Note: Determine the left and right sides of the machine from the normal operating position.

Recommended Maintenance Schedule(s)

Maintenance Service Interval	Maintenance Procedure
After the first use	<ul style="list-style-type: none">• Change the engine oil.
Before each use or daily	<ul style="list-style-type: none">• Test the safety interlock system.• Check the engine oil level.• Check the cutting blades.• Clean the mower housing.
Every 25 hours	<ul style="list-style-type: none">• Grease all lubrication points.• Clean the foam air filter element (more often in dirty or dusty conditions).• Check tire pressure.• Check the belts for wear/cracks.
Every 50 hours	<ul style="list-style-type: none">• Change the engine oil.• Check the battery electrolyte level.
Every 100 hours	<ul style="list-style-type: none">• Replace the paper air filter element (more often in dirty or dusty conditions).• Change the oil filter (model 74403 only).• Replace fuel filter.• Replace spark plug.
Before storage	<ul style="list-style-type: none">• Drain the fuel tank.• Charge the battery and disconnect battery cables.• Perform all maintenance procedures listed above before storage.• Paint any chipped surfaces.

Important: Refer to your engine operator's manual for additional maintenance procedures.



If you leave the key in the ignition switch, someone could accidentally start the engine and seriously injure you or other bystanders.

Remove the key from the ignition and disconnect the wire from the spark plug before you do any maintenance. Set the wire aside so that it does not accidentally contact the spark plug.

Premaintenance Procedures

Removing and Installing the Engine Hood

1. To remove the hood, loosen the knobs and then pull the hood back and up (Figure 17).

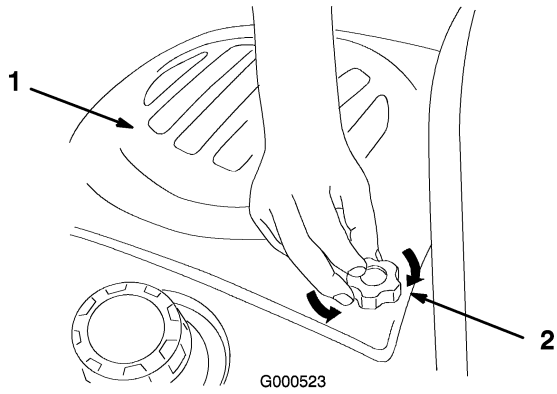

Figure 17

1. Engine hood
2. Knob

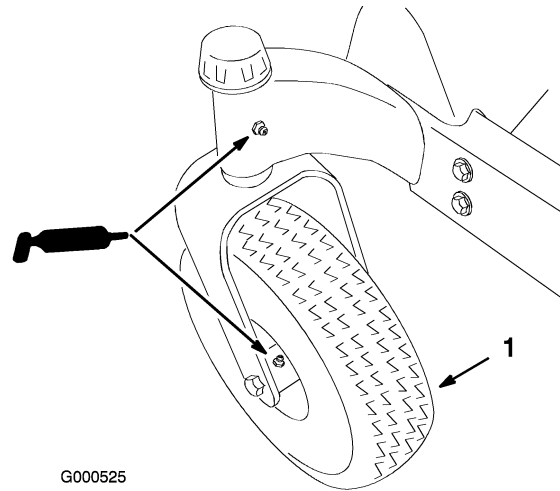

Figure 19

1. Front caster tire

2. To install the hood, put the hooks into the slots and slide forward (Figure 18).
3. Tighten the knobs in the engine hood (Figure 17).

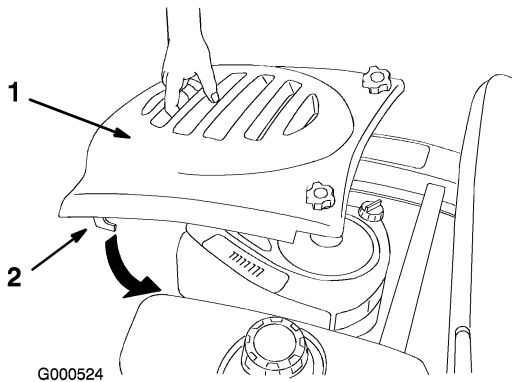

Figure 18

1. Engine hood
2. Hook

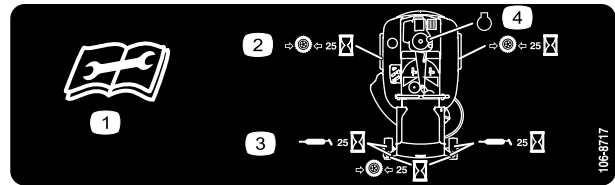

Figure 20

4. Connect a grease gun to each fitting (Figure 19 and Figure 20). Pump grease into the fittings until grease begins to ooze out of the bearings.
5. Wipe up any excess grease.

Lubrication

Greasing the Bearings

Grease the front caster pivots and wheels (Figure 19).

1. Park the machine on a level surface and disengage the blade control (PTO).
2. Move the motion control levers to the brake position, stop the engine, remove the key, and wait for all moving parts to stop before leaving the operating position.
3. Clean the grease fittings (Figure 19 and Figure 20) with a rag. Make sure to scrape any paint off of the front of the fitting(s).

Engine Maintenance

Servicing the Air Cleaner

Foam Element: Clean after every 25 operating hours, or yearly, whichever occurs first.

Paper Element: Replace after every 100 operating hours or yearly, whichever occurs first.

Note: Service the air cleaner more frequently (every few hours) if operating conditions are extremely dusty or sandy.

Removing the Foam and Paper Elements

1. Park the machine on a level surface and disengage the blade control (PTO).

2. Move the motion control levers to the brake position, stop the engine, remove the key, and wait for all moving parts to stop before leaving the operating position.
3. Clean around the air cleaner to prevent dirt from getting into the engine and causing damage. Pull up on the air cleaner cover handle and rotate it toward the engine (Figure 21). Remove the air cleaner cover.

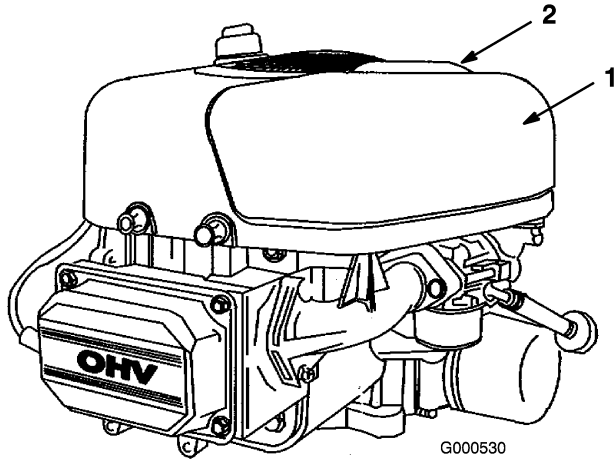

Figure 21

1. Air cleaner cover
2. Air cleaner cover handle

4. Carefully slide the paper element and foam element from the blower housing (Figure 22).

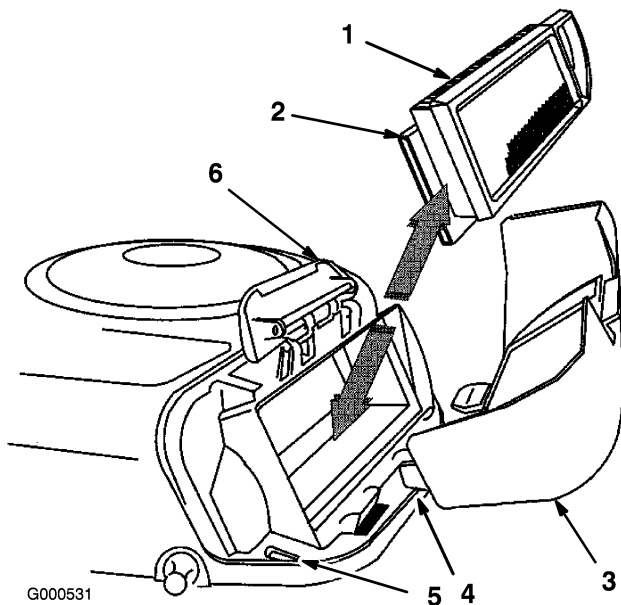

Figure 22

1. Paper element
2. Foam element
3. Air cleaner cover
4. Tab
5. Slot
6. Blower housing

Cleaning the Foam Element

1. Wash the foam element in liquid soap and warm water. When the element is clean, rinse it thoroughly.
2. Dry the element by squeezing it in a clean cloth. Do not oil the element.

Important: Replace the foam element if it is torn or worn.

Important: Do not clean or oil the paper element. Replace the paper element if it is damaged or cannot be cleaned thoroughly.

Installing the Foam and Paper Elements

Important: To prevent engine damage, always operate the engine with the complete foam and paper air cleaner assembly installed.

1. Place the foam element and paper element into the blower housing.

Note: Make sure that the rubber seal is flat against the air cleaner base.

2. Align the tabs on the air cleaner cover with the slots of the blower housing (Figure 22). Hook the handle onto the cover and press down on the handle to lock the cover in place.

Servicing the Engine Oil

Check the oil level daily or after every 8 hours.

Change the oil after the first 5 operating hours and every 50 operating hours thereafter.

Oil Type: Detergent oil (API service SF, SG, SH, SJ, or higher)

Crankcase Capacity:

- 48 oz./1-1/2 qt. (1400 cc/1.4 l) when the filter is not changed;
- 56 oz./1-3/4 qt. (1700 cc/1.7 l) when the filter is changed (Model 74403 only)

Viscosity: See the table below.

USE THESE SAE VISCOSITY OILS

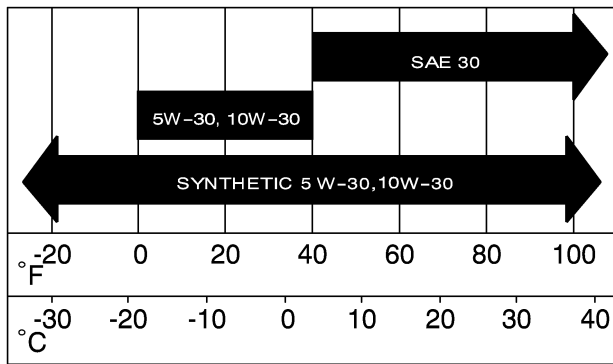

G000526

Figure 23

Checking the Oil Level

1. Park the machine on a level surface, disengage the PTO, stop the engine, and remove the key.
2. Clean around the oil dipstick (Figure 24) so that dirt cannot fall into the fill hole and damage the engine.

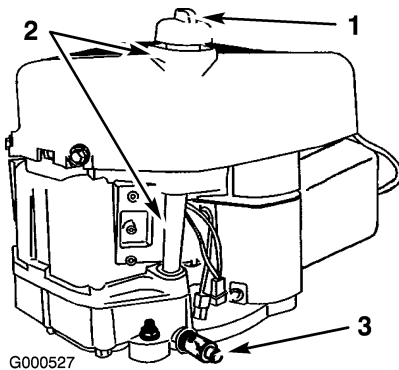

G000527

Figure 24

1. Oil dipstick
2. Filler tube
3. Oil drain valve

3. Unscrew the oil dipstick and wipe the metal end clean (Figure 25).

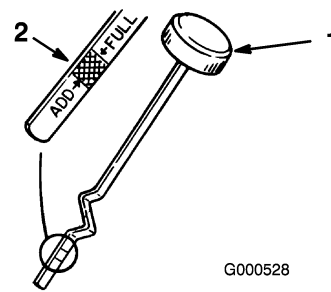

G000528

Figure 25

1. Oil dipstick
2. Metal end

4. Screw the oil dipstick fully onto the fill hole. Unscrew the dipstick, pull it out, and look at the metal end. If the oil level is low, slowly pour only enough oil into the fill hole to raise the level to, but not over, the Full mark on the dipstick.

Important: Do not overfill the crankcase with oil because the engine may be damaged.

Changing the Oil

1. Start the engine and let it run five minutes. This warms the oil so it drains better.
2. Park the machine so that the drain side is slightly lower than the opposite side to assure the oil drains completely.
3. Disengage the PTO and set the parking brake.
4. Stop the engine, remove the key, and wait for all moving parts to stop before leaving the operating position.
5. Slide the drain hose over the drain valve.
6. Place a pan below the drain hose. Rotate oil drain valve to allow oil to drain (Figure 26).

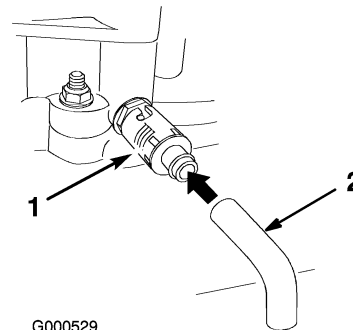

G000529

Figure 26

1. Oil drain valve
2. Oil drain tube

7. When oil has drained completely, close the drain valve.
8. Remove the drain hose (Figure 26).

Note: Dispose of the used oil at a recycling center.

9. Change the oil filter, if necessary (Figure 27).
10. Clean around the oil dipstick and unscrew the cap (Figure 24).
11. Slowly pour approximately 80% of the specified oil into the filler tube (Figure 24).
12. Check the oil level; refer to Checking the Oil Level in Engine Maintenance, page 22.
13. Slowly add additional oil to bring it to the full mark.

Changing the Oil Filter (For Model 74403 only)

Replace the oil filter every 100 hours or every other oil change.

Note: Change the oil filter more often in dusty, dirty conditions.

1. Drain the oil from the engine; refer to Changing and Draining the Oil in Engine Maintenance, page 22.
2. Remove the old filter and wipe the filter adapter gasket surface (Figure 27).
3. Apply a thin coat of clean oil to the rubber gasket on the replacement filter (Figure 27).

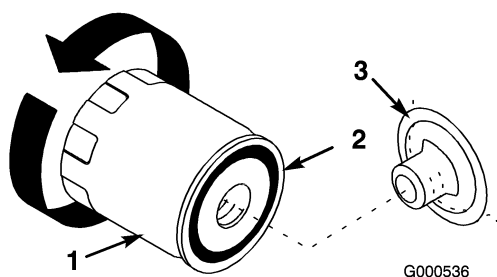

Figure 27

- | | |
|---------------|------------|
| 1. Oil filter | 3. Adapter |
| 2. Gasket | |

4. Install the replacement oil filter to the filter adapter. Turn the oil filter clockwise until the rubber gasket contacts the filter adapter; then tighten the filter an additional 1/2 to 3/4 turn (Figure 27).
5. Fill the crankcase with the proper type of new oil; refer to Changing and Draining the Oil in Engine Maintenance, page 22.

Fuel System Maintenance

Draining the Fuel Tank



In certain conditions, gasoline is extremely flammable and highly explosive. A fire or explosion from gasoline can burn you and others and can damage property.

- Drain gasoline from the fuel tank when the engine is cold. Do this outdoors in an open area. Wipe up any gasoline that spills.
- Never smoke when draining gasoline, and stay away from an open flame or where a spark may ignite the gasoline fumes.

1. Park the machine on a level surface and disengage the blade control (PTO).
2. Move the motion control levers to the brake position, stop the engine, remove the key, and wait for all moving parts to stop before leaving the operating position.
3. Close the fuel shut-off valve located under the front of the fuel tank.
4. Loosen the hose clamp at the fuel filter and slide it up the fuel line away from the fuel filter (Figure 28).

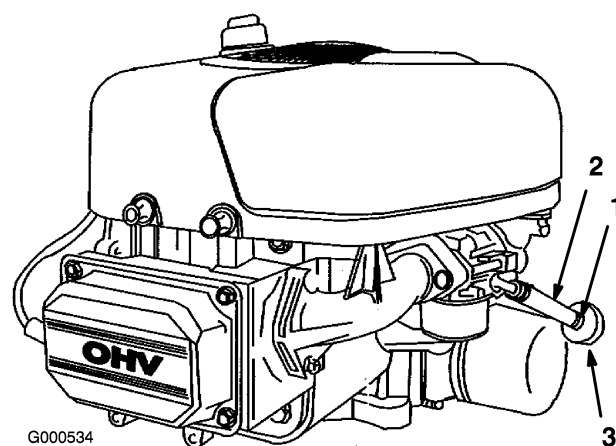

Figure 28

- | | |
|---------------|-----------|
| 1. Hose clamp | 3. Filter |
| 2. Fuel line | |

5. Pull the fuel line off of the fuel filter (Figure 28).
6. Open the fuel shut-off valve. Allow gasoline to drain into a gas can or drain pan.

Note: Now is the best time to install a new fuel filter because the fuel tank is empty.

7. Install the fuel line onto the fuel filter. Slide the hose clamp close to the fuel filter to secure the fuel line (Figure 28).

Replacing the Fuel Filter

Replace the fuel filter after every 100 operating hours or yearly, whichever occurs first.

Never install a dirty filter if it is removed from the fuel line.

1. Park the machine on a level surface and disengage the blade control (PTO).
2. Move the motion control levers to the brake position, stop the engine, remove the key, and wait for all moving parts to stop before leaving the operating position.
3. Close the fuel shut-off valve located under the front of the fuel tank.
4. Squeeze the ends of the hose clamps together and slide them away from the filter (Figure 29).

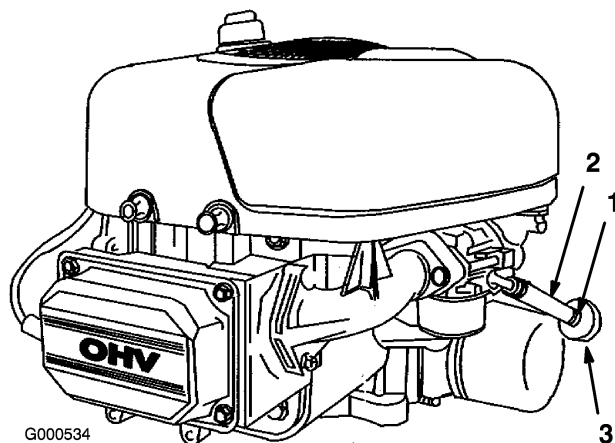

Figure 29

1. Hose clamp
2. Fuel line
3. Filter

5. Remove the filter from the fuel lines.
6. Install a new filter and move the hose clamps close to the filter (Figure 29).
7. Open the fuel shut-off valve.

Electrical System Maintenance

Servicing the Spark Plug

Replace the spark plug after every 100 operating hours. Make sure that the air gap between the center and side electrodes is correct before installing the spark plug. Use a spark plug wrench for removing and installing the spark plug(s) and a gapping tool/feeler gauge to check and adjust the air gap. Install a new spark plug if necessary.

Type: Champion RC12YC (or equivalent)

Air Gap: 0.030 inch (0.76 mm)

Removing the Spark Plug

1. Disengage the PTO, set the parking brake, stop the engine, and remove the key.
2. Pull the wire off of the spark plug (Figure 30). Clean around the spark plug to prevent dirt from falling into the engine and potentially causing damage.
3. Remove the spark plug and metal washer.

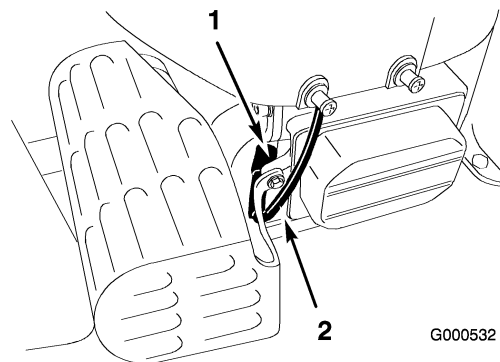

Figure 30

1. Spark plug
2. Spark plug wire

Checking the Spark Plug

1. Look at the center of the spark plug (Figure 31). If you see light brown or gray on the insulator, the engine is operating properly. A black coating on the insulator usually means the air cleaner is dirty.

Important: Never clean the spark plug. Always replace the spark plug when it has a black coating, worn electrodes, an oily film, or cracks.

2. Check the gap between the center and side electrodes (Figure 31). Bend the side electrode (Figure 31) if the gap is not correct.

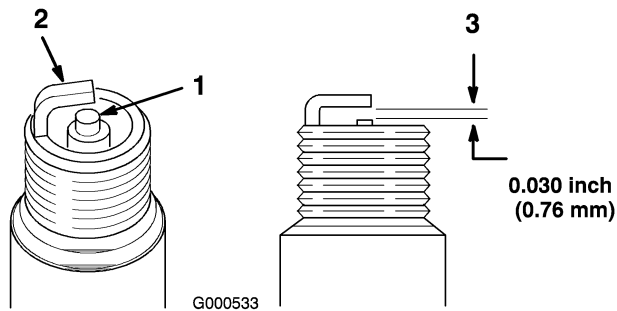

Figure 31

1. Center electrode insulator
2. Side electrode
3. Air gap (not to scale)

Installing the Spark Plug

1. Install the spark plug. Make sure that the air gap is set correctly.
2. Tighten the spark plug to 30 ft-lb (41 N·m).
3. Push the wire onto the spark plug (Figure 30).

Servicing the Battery

Check the electrolyte level in the battery every 25 hours. Always keep the battery clean and fully charged. Use a paper towel to clean the battery case. If the battery terminals are corroded, clean them with a solution of four parts water and one part baking soda. Apply a light coating of grease to the battery terminals to prevent corrosion.

Voltage: 12 V

Removing the Battery

Battery terminals or metal tools could short against metal machine components causing sparks. Sparks can cause the battery gasses to explode, resulting in personal injury.

- When removing or installing the battery, do not allow the battery terminals to touch any metal parts of the machine.
- Do not allow metal tools to short between the battery terminals and metal parts of the machine.

1. Park the machine on a level surface and disengage the blade control (PTO).
2. Move the motion control levers to the brake position, stop the engine, remove the key, and wait for all moving parts to stop before leaving the operating position.

3. Tip the seat forward to see the battery.
4. Disconnect the negative (black) ground cable from the battery post (Figure 32).

!

Incorrect battery cable routing could damage the machine and cables causing sparks. Sparks can cause the battery gasses to explode, resulting in personal injury.

- Always disconnect the negative (black) battery cable before disconnecting the positive (red) cable.
- Always connect the positive (red) battery cable before connecting the negative (black) cable.

5. Slide the rubber cover up the positive (red) cable. Disconnect the positive (red) cable from the battery post (Figure 32).
6. Remove the battery hold-down (Figure 32) and lift the battery from the battery tray.

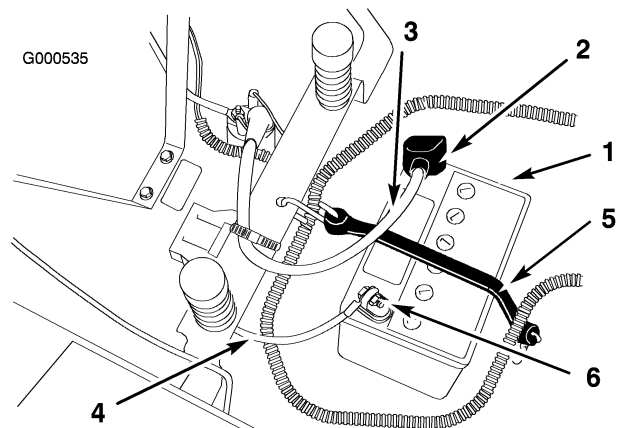

Figure 32

1. Battery
2. Terminal boot
3. Positive battery cable
4. Negative battery cable
5. Battery hold-down
6. Bolt, nut, and washer

Checking the Battery Electrolyte Level

Battery electrolyte contains sulfuric acid which is a deadly poison and causes severe burns.

- Do not drink electrolyte and avoid contact with skin, eyes or clothing. Wear safety glasses to shield your eyes and rubber gloves to protect your hands.
- Fill the battery where clean water is always available for flushing the skin.

1. Tip the seat forward to see the battery.
2. Look at the side of the battery. The electrolyte must be up to the Upper line (Figure 32). Do not allow the electrolyte to fall below the Lower line (Figure 32).

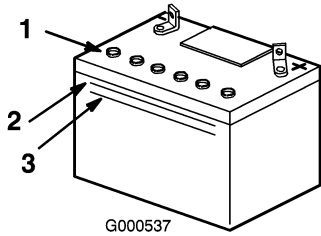

Figure 33

- | | |
|---------------|---------------|
| 1. Vent caps | 3. Lower line |
| 2. Upper line | |

3. If the electrolyte is low, add the required amount of distilled water; refer to Adding Water to the Battery in Electrical System Maintenance, page 26.

Adding Water to the Battery

The best time to add distilled water to the battery is just before you operate the machine. This lets the water mix thoroughly with the electrolyte solution.

1. Remove the battery from the machine; refer to Removing the Battery in Electrical System Maintenance, page 26.

Important: Never fill the battery with distilled water while the battery is installed in the machine. Electrolyte could be spilled on other parts and cause corrosion.

2. Clean the top of the battery with a paper towel.
3. Remove the vent caps from the battery (Figure 32).
4. Slowly pour distilled water into each battery cell until the electrolyte level is up to the Upper line (Figure 32) on the battery case.

Important: Do not overfill the battery because electrolyte (sulfuric acid) can cause severe corrosion and damage to the chassis.

5. Wait five to ten minutes after filling the battery cells. Add distilled water, if necessary, until the electrolyte level is up to the Upper line (Figure 32) on the battery case.
6. Reinstall the battery vent caps.

Charging the Battery

Important: Always keep the battery fully charged (1.260 specific gravity). This is especially important to prevent battery damage when the temperature is below 32°F (0°C).

1. Remove the battery from the chassis; refer to Removing the Battery.
2. Check the electrolyte level; refer to Checking the Electrolyte Level.
3. Make sure that the vent caps are installed in the battery. Charge the battery for 1 hour at 25 to 30 amps or 6 hours at 4-6 amps. Do not overcharge the battery.
4. When the battery is fully charged, unplug the charger from the electrical outlet, then disconnect the charger leads from the battery posts (Figure 34).

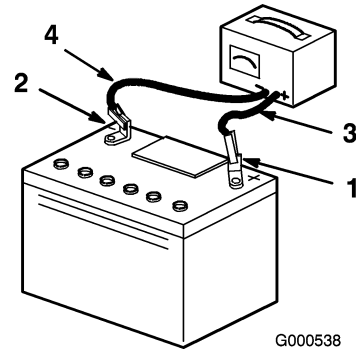

Figure 34

- | | |
|--------------------------|---------------------------|
| 1. Positive battery post | 3. Red (+) charger lead |
| 2. Negative battery post | 4. Black (-) charger lead |

5. Install the battery in the machine and connect the battery cables; refer to Installing the Battery.

Note: Do not run the machine with the battery disconnected, electrical damage may occur.

Installing the Battery

1. Position the battery in the tray with the terminal posts away from the control panel (Figure 32).
2. Install the positive (red) battery cable to the positive (+) battery terminal.
3. Install the negative battery cable to the negative (-) battery terminal.
4. Secure the cables with 2 bolts (1/4 x 3/4 inch), washers (1/4 inch), and nuts (1/4 inch) (Figure 32).
5. Slide the red terminal boot onto the positive (red) battery post.
6. Secure the battery with the hold-down (Figure 32).

Servicing the Fuses

The electrical system is protected by fuses. It requires no maintenance; however, if a fuse blows, check the component/circuit for a malfunction or short.

Fuse:

- Main F1-30 amp, blade-type
 - Charge Circuit F2-25 amp, blade-type
 - Optional Headlight Kit-10 amp, blade type
1. Raise the seat to gain access to the fuse holder (Figure 35).
 2. To replace a fuse, pull out on the fuse to remove it (Figure 35).

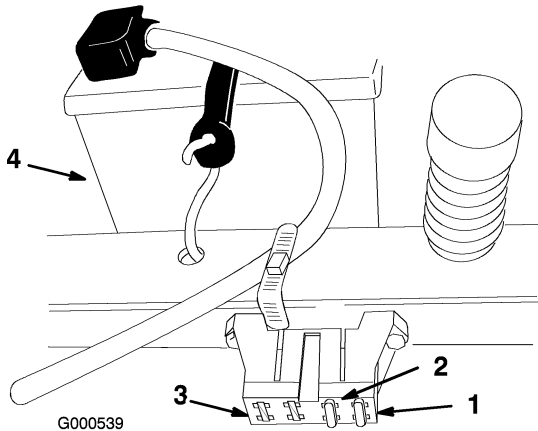

Figure 35

- | | |
|--------------------------|--|
| 1. Main-30 amp | 3. For optional Headlight Kit-10 amp Battery |
| 2. Charge circuit-25 amp | |

Drive System Maintenance

Checking the Tire Pressure

Maintain the air pressure in the front and rear tires as specified. Uneven tire pressure can cause uneven cut. Check the pressure at the valve stem after every 50 operating hours or monthly, whichever occurs first (Figure 36). Check the tires when they are cold to get the most accurate pressure reading.

Rear Tires: 13 psi (90 kPa)

Front Tires (castor wheels): 35 psi (139 kPa)

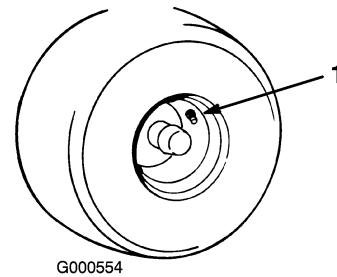

Figure 36

1. Valve stem

Mower Maintenance

Servicing the Cutting Blades

The Toro bullhorn logo (Figure 37) is a registered trademark of the Toro Company. It identifies the component it appears on as a genuine Toro part. The logo, depicted below, appears on genuine Toro cutting blades.

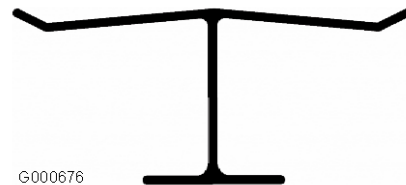

Figure 37

Maintain sharp blades throughout the cutting season because sharp blades cut cleanly without tearing or shredding the grass blades. Tearing and shredding turns grass brown at the edges, which slows growth and increases the chance of disease.

Check the cutter blades daily for sharpness, and for any wear or damage. File down any nicks and sharpen the blades as necessary. If a blade is damaged or worn, replace it immediately with a genuine Toro replacement blade. For convenient sharpening and replacement, you may want to keep extra blades on hand.



A worn or damaged blade can break, and a piece of the blade could be thrown into the operator's or bystander's area, resulting in serious personal injury or death.

- Inspect the blade periodically for wear or damage.
- Replace a worn or damaged blade.

Before Inspecting or Servicing the Blades

Park the machine on a level surface, disengage the PTO, and move the motion control levers to the brake position. Stop the engine, remove the key, and disconnect the spark plug wire(s) from the spark plug(s).

Inspecting the Blades

1. Inspect the cutting edges (Figure 38). If the edges are not sharp or have nicks, remove and sharpen the blades; refer to Sharpening the Blades.
2. Inspect the blades, especially the curved area (Figure 38). If you notice any damage, wear, or a slot forming in this area (item 3 in Figure 38), immediately install a new blade.

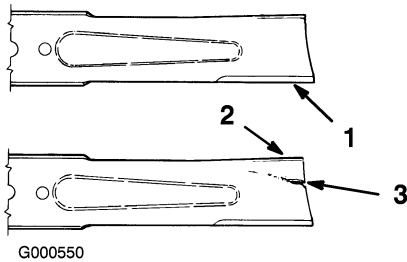

Figure 38

- | | |
|-----------------|----------------------|
| 1. Cutting edge | 3. Wear/slot forming |
| 2. Curved area | |

Checking for Bent Blades

1. Rotate the blades until the ends face forward and backward (Figure 39). Measure from a level surface to the cutting edge, position **A**, of the blades (Figure 39). Note this dimension.

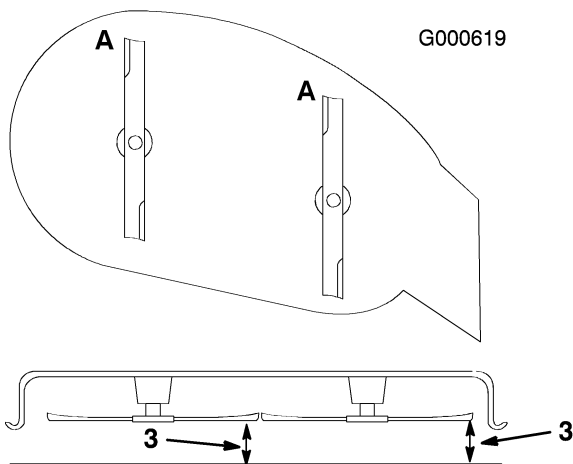

Figure 39

2. Rotate the opposite ends of the blades forward.
3. Measure from a level surface to the cutting edge of the blades at the same position as in step 1. The difference between the dimensions obtained in steps 1 and 2 must not exceed 1/8 inch (3 mm). If this dimension exceeds 1/8 inch (3 mm), the blade is bent and must be replaced. Refer to Removing the Blades and Installing the Blades.



A blade that is bent or damaged could break apart and could seriously injure or kill you or bystanders.

- Always replace bent or damaged blade with a new blade.
- Never file or create sharp notches in the edges or surfaces of blade.

Removing the Blades

The blades must be replaced if a solid object is hit, if the blade is out of balance, or the blade is bent. To ensure optimum performance and continued safety conformance of the machine, use genuine Toro replacement blades. Replacement blades made by other manufacturers may result in non-conformance with safety standards.

Hold the blade end using a rag or thickly-padded glove. Remove the blade bolt, curved washer, blade stiffener, and blade from the spindle shaft (Figure 40).

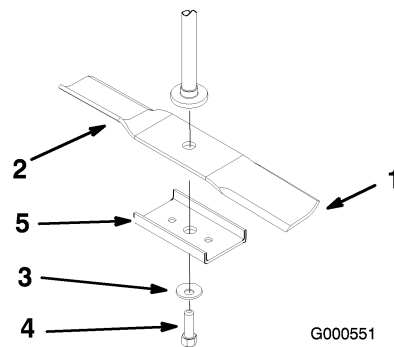

Figure 40

- | | |
|-----------------------|--------------------|
| 1. Sail area of blade | 4. Blade bolt |
| 2. Blade | 5. Blade stiffener |
| 3. Curved washer | |

Sharpening the Blades

1. Use a file to sharpen the cutting edge at both ends of the blade (Figure 41). Maintain the original angle. The blade retains its balance if the same amount of material is removed from both cutting edges.

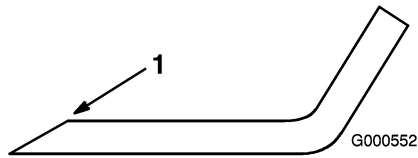

Figure 41

1. Sharpen at original angle

2. Check the balance of the blade by putting it on a blade balancer (Figure 42). If the blade stays in a horizontal position, the blade is balanced and can be used. If the blade is not balanced, file some metal off the end of the sail area only (Figure 41). Repeat this procedure until the blade is balanced.

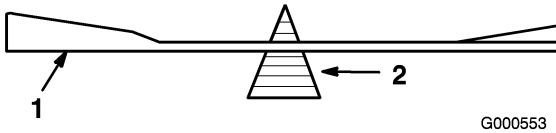

Figure 42

1. Blade
2. Balancer

Installing the Blades

1. Install the blade onto the spindle shaft (Figure 40).

Important: The curved part of the blade must be pointing upward toward the inside of the mower to ensure proper cutting.

2. Install the blade stiffener, the curved washer (cupped side toward the blade) and the blade bolt (Figure 40).
3. Torque the blade bolt to 35-65 ft-lb (47-88 N m).

Leveling the Mower from Side-to-Side

The mower blades must be level from side to side. Check the side-to-side level any time you install the mower or when you see an uneven cut on your lawn.

1. Park the machine on a level surface and disengage the blade control (PTO).
2. Move the motion control levers to the brake position, stop the engine, remove the key, and wait for all moving parts to stop before leaving the operating position.
3. Check the air pressure of all four tires. If needed, adjust to the recommended inflation; refer to Checking the Tire Pressure in Drive System Maintenance, page 29.
4. Set the height-of-cut lever to position 3 [3 inch (76 mm)].

5. Carefully rotate the blade(s) side to side (Figure 48). Measure between the outside cutting edges and the flat surface (Figure 48). If both measurements are not within 3/16 inch (5 mm), an adjustment is required; continue with this procedure.

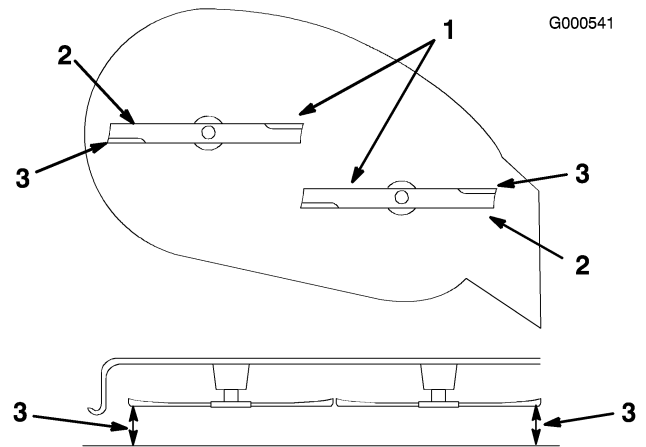

Figure 43

1. Blades side to side
2. Outside cutting edges
3. Measure here

6. Remove the hairpin cotter and washer from the leveling bracket (Figure 44).
7. To level the blade(s), reposition the leveling bracket(s) in a different hole and install the washer and hairpin cotter. (Figure 44 and Figure 45). A front hole lowers the blade height and a rear hole raises its height. Adjust both sides as required.

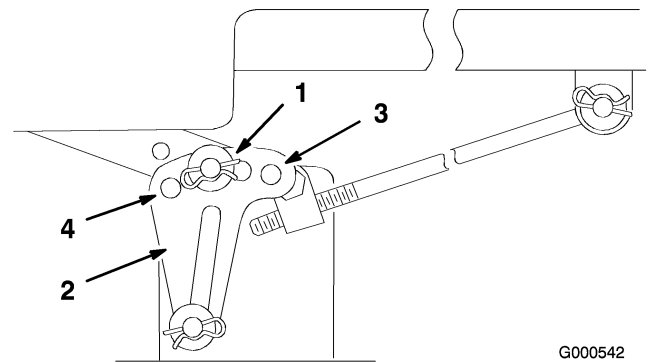

Figure 44

1. Hairpin cotter and washer
2. Leveling bracket-42 inch model shown
3. Front hole
4. Rear hole

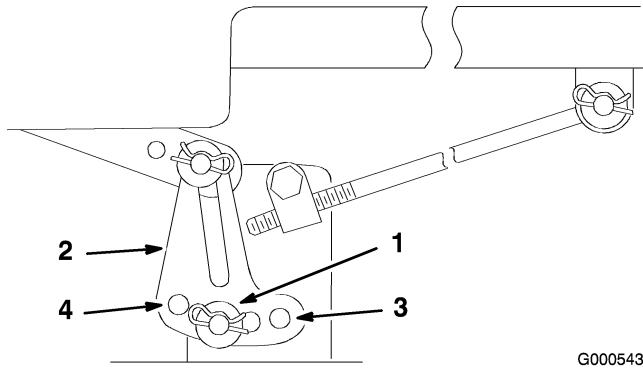

Figure 45

- | | |
|---|---------------|
| 1. Hairpin cotter and washer | 3. Front hole |
| 2. Leveling bracket-38 inch model shown | 4. Rear hole |

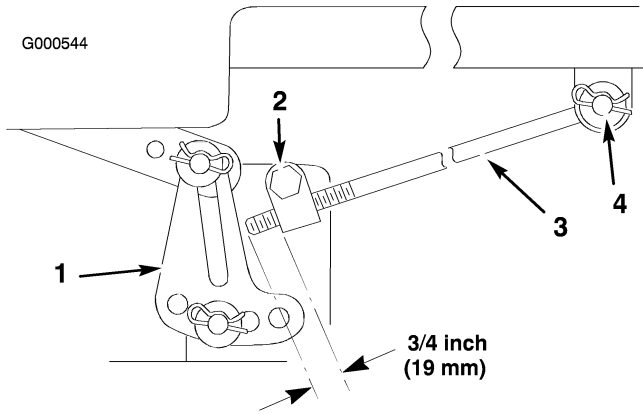

Figure 46

- | | |
|---|------------------------------|
| 1. Leveling bracket-38 inch model shown | 3. Adjusting rod |
| 2. Adjusting block | 4. Hairpin cotter and washer |

8. Check the front-to-rear blade slope; refer to Adjusting the Front-to-Rear Blade Slope.

Adjusting the Front-to-Rear Blade Slope

Check the front-to-rear blade level any time you install the mower. If the front of the mower is more than 5/16 inch (7.9 mm) lower than the rear of the mower, adjust the blade level using the following instructions:

1. Park the machine on a level surface and disengage the blade control (PTO).
2. Move the motion control levers to the brake position, stop the engine, remove the key, and wait for all moving parts to stop before leaving the operating position.
3. Check the air pressure of all four tires. If needed, adjust to the recommended inflation; refer to Checking the Tire Pressure in Drive System Maintenance, page 29.
4. Check and adjust the side-to-side blade level if you have not checked the setting; refer to Leveling the Mower from Side-to-Side.
5. Measure the length of the rod extending out of the adjusting block on the sides of the chassis (Figure 46).
6. If the rod length is **not** a 3/4 inch (19 mm), remove the hairpin cotter and washer from the end of the adjusting rod (Figure 46) and turn the rod until the 3/4 inch (19 mm) dimension is obtained.
7. Install the end of the rod into the hole in the mower mount and secure it with the washer and hairpin cotter.

8. Repeat steps 5 through 7 for the opposite side of the mower.
9. Set the height-of-cut at position 3 [3 inch (76 mm)] and carefully rotate the blades so they are facing front to rear (Figure 47).
10. Measure from the tip of the front blade to the flat surface and the tip of the rear blade to the flat surface (Figure 47). If the front blade tip is not 1/16-5/16 inch (1.6-7.9 mm) lower than the rear blade tip, adjust the front locknuts.

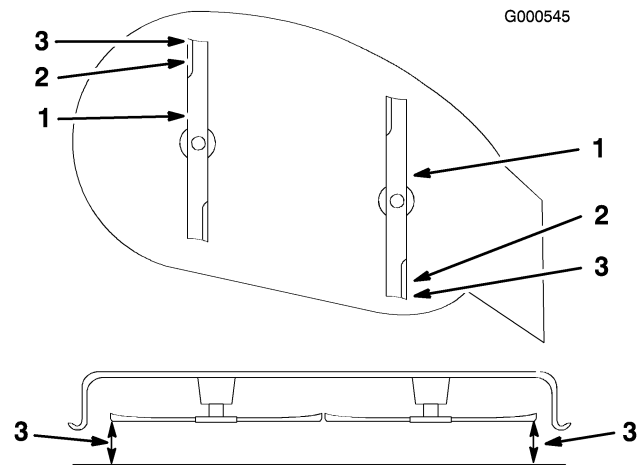

Figure 47

- | | |
|--------------------------|-----------------|
| 1. Blades front to rear | 3. Measure here |
| 2. Outside cutting edges | |

11. To adjust the front-to-rear blade slope, remove the locknuts and then rotate the adjustment nuts in the front of the mower (Figure 48).
12. To raise the front of the mower, tighten the adjustment nuts. To lower the front of the mower, loosen the adjustment nuts.

- After adjusting both adjustment nuts evenly, check the front-to-rear slope again. Continue adjusting the nuts until the front blade tip is 1/16-5/16 inch (1.6-7.9 mm) lower than the rear blade tip (Figure 48).

Note: After adjusting the adjustment nuts, make sure there is no slack in either support rod (Figure 49). Tighten either one to remove the slack (Figure 48).

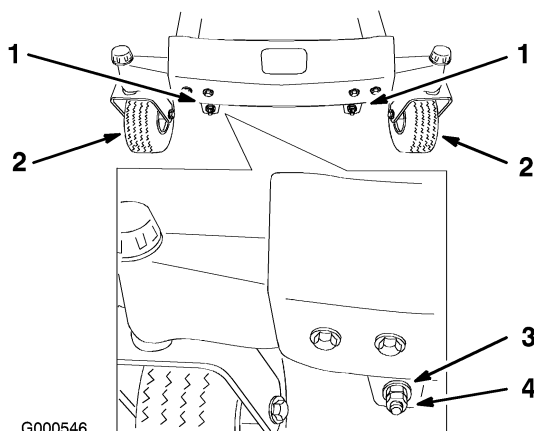

Figure 48

- | | |
|------------------------------|-------------------|
| 1. Locknut and adjusting nut | 3. Adjustment nut |
| 2. Front tire | 4. Lock nut |

- When the front-to-rear blade slope is correct, tighten the lock nuts and check the side-to-side level of the mower; refer to Leveling the Mower from Side-to-Side.

Removing the Mower

Note: Before removing the mower, make a note for which holes are used in the leveling brackets (Figure 50).

- Park the machine on a level surface and disengage the blade control (PTO).
- Move the motion control levers to the brake position, stop the engine, remove the key, and wait for all moving parts to stop before leaving the operating position.
- Lower the height-of-cut lever to the lowest position.
- Remove the hairpin cotter and clevis pin from the front support rod on each side of the mower (Figure 49).

G000547

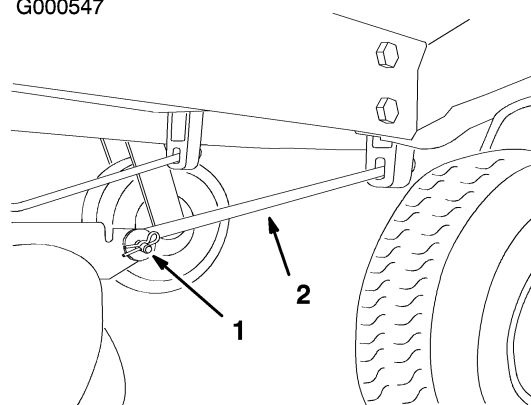

Figure 49

- | | |
|------------------------------|--------------------|
| 1. Hairpin cotter and clevis | 2. Support rod pin |
|------------------------------|--------------------|

- Remove the hairpin cotter and washer from the adjusting rod (Figure 50) on each side of the mower.
- Remove the hairpin cotter and washer at the mower leveling brackets (Figure 50) on each side of the mower. Note which hole the leveling bracket is mounted in for future installation. Slide the brackets off of the mounting pin.

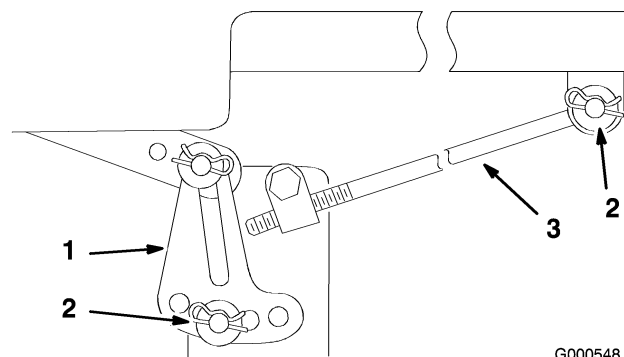

Figure 50

- | | |
|---|------------------|
| 1. Leveling bracket-38 inch model shown | 3. Adjusting rod |
| 2. Hairpin cotter and washer | |

- Slide the mower rearward to remove the mower belt from the engine pulley.
- Slide the mower out from underneath the machine.

Note: Retain all parts for future installation.

Mower Belt Maintenance

Inspecting the Belts

Inspect all belts every 100 hours.

Check the belts for cracks, frayed edges, burn marks, or any other damage. Replace damaged belts.

Replacing the Mower Belt

Squealing when the belt is rotating, blades slipping when cutting grass, frayed belt edges, burn marks, and cracks are signs of a worn mower belt. Replace the mower belt if any of these conditions are evident.

1. Park the machine on a level surface and disengage the blade control (PTO).
2. Move the motion control levers to the brake position, stop the engine, remove the key, and wait for all moving parts to stop before leaving the operating position.
3. Set the height-of-cut at 1.5 [1-1/2 inch (38 mm)].
4. Remove the belt covers over the outside spindles and loosen the belt guide (Figure 51).

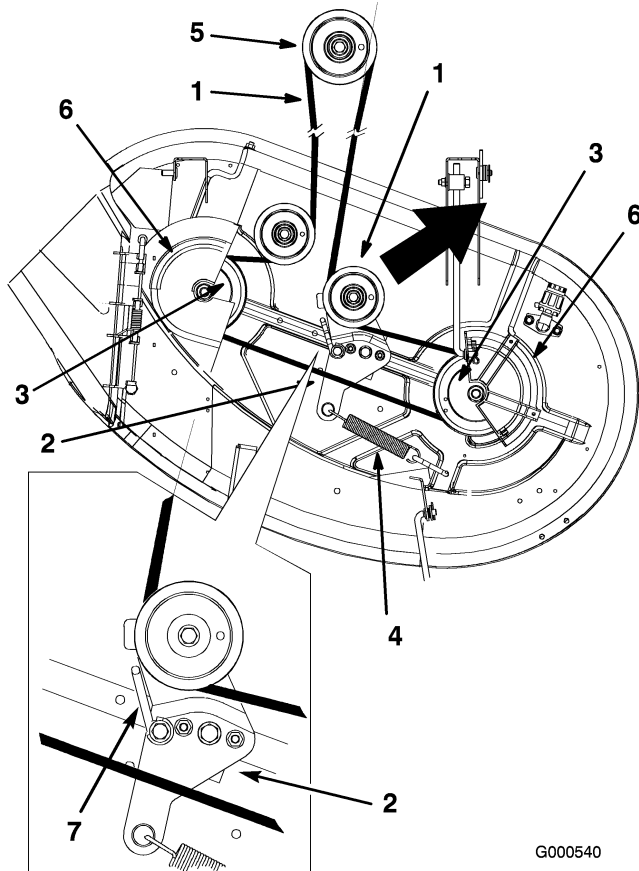

Figure 51

- | | |
|-------------------|------------------|
| 1. Mower belt | 5. Engine pulley |
| 2. Idler arm | 6. Belt cover |
| 3. Outside pulley | 7. Belt guide |
| 4. Spring | |

G000540

5. Pull the idler pulley in the direction shown in Figure 51 and roll the belt off of the pulleys.



The spring is under tension when installed and can cause personal injury.

Be careful when removing the spring.

6. Route the new belt around the engine pulley and mower pulleys (Figure 51).
7. Pull the idler pulley in the direction shown in Figure 51 and route the belt onto the idler pulley (Figure 51).
8. Rotate the belt guide, on the idler arm, towards the pulley until it stops (Figure 51).
9. Tighten the belt guide (Figure 51).
10. Install the belt covers over the outside spindles.

Installing the Mower

1. Park the machine on a level surface and disengage the blade control (PTO).
2. Move the motion control levers to the brake position, stop the engine, remove the key, and wait for all moving parts to stop before leaving the operating position.
3. Slide the mower under the machine.
4. Lower the height-of-cut lever to the lowest position.
5. Attach the adjusting rod to the machine with the washer and hairpin cotter (Figure 50) on each side of the mower.
6. Slide the leveling brackets onto the mounting pins and secure them with the washers and hairpin cotters (Figure 50).
7. Attach the front support rods to the machine with the clevis pins and hairpin cotters (Figure 49).
8. Install the mower belt onto the engine pulley; refer to Replacing the Mower Belt.

Replacing the Grass Deflector



An uncovered discharge opening could allow the lawn mower to throw objects in the operator's or bystander's direction and result in serious injury. Also, contact with the blade could occur.

Never operate the lawn mower unless you install a cover plate, a mulch plate, or a grass chute and catcher.

1. Locate items shown in Figure 52.

2. Remove the nut (3/8 inch) from the rod under the mower (Figure 52).
3. Slide the rod out of the short stand-off, internal lock washer, spring, and grass deflector (Figure 52). Remove the damaged or worn grass deflector.
4. Replace the grass deflector and internal lock washer (Figure 52).
5. Slide rod, straight end, through the rear grass deflector bracket.
6. Place the spring on the rod, with end wires down, and between the grass deflector brackets. Slide rod through second grass deflector bracket and internal lock washer (Figure 52).
7. Insert rod at front of grass deflector into short stand-off on deck. Secure rear end of rod into the mower with a nut (3/8 inch) (Figure 52).

Important: The grass deflector must be spring loaded in the down position. Lift the deflector up to test that it snaps to the full down position.

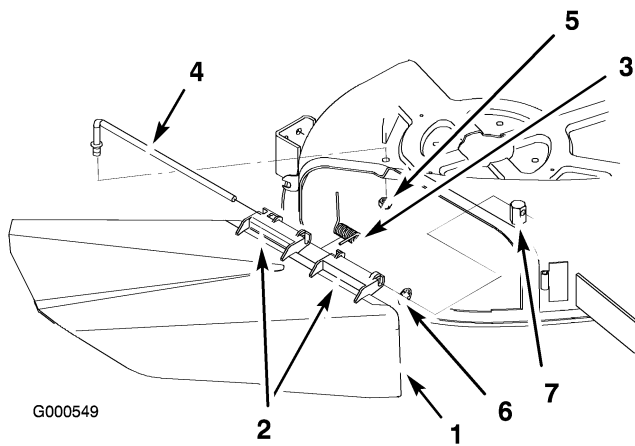

Figure 52

- | | |
|----------------------------|--------------------|
| 1. Grass deflector | 5. Nut, 3/8 inch |
| 2. Grass deflector bracket | 6. Rubber o-ring |
| 3. Spring | 7. Short stand-off |
| 4. Rod | |

2. Move the motion control levers to the brake position, stop the engine, remove the key, and wait for all moving parts to stop before leaving the operating position.
3. Attach the hose coupling to the end of the mower washout fitting, and turn the water on high (Figure 53).

Note: Spread petroleum jelly on the washout fitting o-ring to make the coupling slide on easier and protect the o-ring.

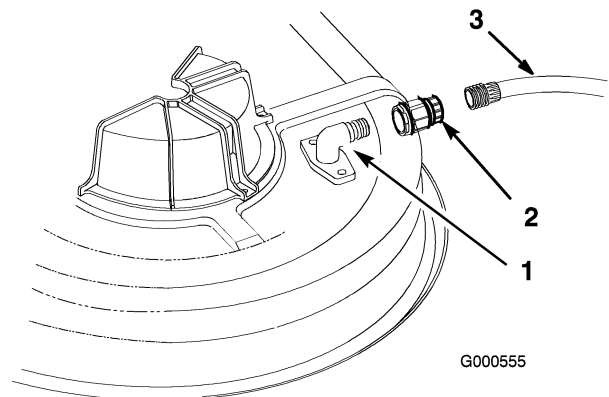

Figure 53

- | | |
|--------------------|---------|
| 1. Washout fitting | 3. Hose |
| 2. Coupling | |

4. Lower the mower to the lowest height-of-cut.
5. Sit on the seat and start the engine. Engage the PTO and let the mower run for one to three minutes.
6. Disengage the PTO, stop the engine, and remove the ignition key. Wait for all moving parts to stop.
7. Turn the water off and remove the coupling from the washout fitting.

Note: If the mower is not clean after one washing, soak it and let it stand for 30 minutes. Then repeat the process.

8. Run the mower again for one to three minutes to remove excess water.

Cleaning

Washing the Underside of the Mower

After each use, wash the underside of the mower to prevent grass buildup for improved mulch action and clipping dispersal.

1. Park the machine on a level surface and disengage the blade control (PTO).



A broken or missing washout fitting could expose you and others to thrown objects or blade contact. Contact with blade or thrown debris can cause injury or death.

- **Replace broken or missing washout fitting immediately, before using mower again.**
- **Plug any hole(s) in mower with bolts and locknuts.**
- **Never put your hands or feet under the mower or through openings in the mower.**

Storage

Cleaning and Storage

1. Disengage the PTO, set the parking brake, stop the engine, and remove the key.
2. Remove grass clippings, dirt, and grime from the external parts of the entire machine, especially the engine. Clean dirt and chaff from the outside of the engine cylinder head fins and blower housing.

Important: You can wash the machine with mild detergent and water. Do not pressure wash the machine. Avoid excessive use of water, especially near the control panel, engine, hydraulic pumps, and motors.

3. Service the air cleaner; refer to Servicing the Air Cleaner in Engine Maintenance, page 22.
4. Grease and oil the machine; refer to Lubrication, page 22.
5. Change the crankcase oil and filter; refer to Servicing the Engine Oil in Engine Maintenance, page 22.
6. Check the tire pressure; refer to Checking the Tire Pressure in Drive System Maintenance, page 29.
7. Charge the battery; refer to Servicing the Battery in Electrical System Maintenance, page 26.
8. Check the condition of the blades; refer to Servicing the Cutting Blades in Mower Maintenance, page 29.
9. Prepare the machine for storage when non-use occurs over 30 days. Prepare the machine for storage as follows.
10. Add a petroleum based stabilizer/conditioner to the fuel in the tank. Follow the mixing instructions from the stabilizer manufacturer. Do not use an alcohol based stabilizer (ethanol or methanol).

Note: A fuel stabilizer/conditioner is most effective when mixed with fresh gasoline and used at all times.

Run the engine to distribute the conditioned fuel through the fuel system (5 minutes).

Stop the engine, allow it to cool, and drain the fuel tank; refer to Draining the Fuel Tank in Fuel System Maintenance, page 25.

Restart the engine and run it until it stops.

Choke or prime the engine. Start and run the engine until it will not start. Operate the primer, if equipped, several times to ensure no fuel remains in the primer system.

Dispose of fuel properly. Recycle as per local codes.

Important: Do not store stabilizer/conditioned gasoline over 90 days.

11. Remove the spark plug(s) and check its condition; refer to Servicing the Spark Plug in Engine Maintenance, page 22. With the spark plug(s) removed from the engine, pour two tablespoons of engine oil into the spark plug hole. Use the starter to crank the engine and distribute the oil inside the cylinder. Install the spark plug(s). Do not install the wire on the spark plug(s).
12. Clean any dirt and chaff from the top of the mower.
13. Scrape any heavy buildup of grass and dirt from the underside of the mower, then wash the mower with a garden hose.
14. Check the condition of the drive and mower belts.
15. Check and tighten all bolts, nuts, and screws. Repair or replace any part that is worn or damaged.
16. Paint all scratched or bare metal surfaces. Paint is available from your Authorized Service Dealer.
17. Store the machine in a clean, dry garage or storage area. Remove the key from the ignition switch and keep it in a memorable place. Cover the machine to protect it and keep it clean.

Troubleshooting

Problem	Possible Cause	Corrective Action
The engine overheats.	<ol style="list-style-type: none"> 1. The engine load is excessive. 2. The oil level in the crankcase is low. 3. The cooling fins and air passages under the engine blower housing are plugged. 4. The air cleaner is dirty. 5. Dirt, water, or stale fuel is in fuel system. 	<ol style="list-style-type: none"> 1. Reduce ground speed. 2. Add oil to the crankcase. 3. Remove the obstruction from the cooling fins and air passages. 4. Clean or replace the air cleaner element. 5. Contact an Authorized Service Dealer
The starter does not crank	<ol style="list-style-type: none"> 1. The blade control (PTO) is engaged. 2. The motion control levers are not in the brake position. 3. The operator is not seated. 4. The battery is dead. 5. The electrical connections are corroded or loose. 6. A fuse is blown. 7. A relay or switch is damaged. 	<ol style="list-style-type: none"> 1. Move the PTO to Disengaged. 2. Move the motion control levers to the brake position. 3. Sit on the seat. 4. Charge the battery. 5. Check the electrical connections for good contact. 6. Replace the fuse. 7. Contact an Authorized Service Dealer.
The engine will not start, starts hard, or fails to keep running.	<ol style="list-style-type: none"> 1. The fuel tank is empty. 2. The fuel valve turned off. 3. The choke is not on. 4. The air cleaner is dirty. 5. The spark plug wire(s) is loose or disconnected. 6. The spark plug(s) is pitted, fouled, or the gap is incorrect. 7. There is dirt in fuel filter. 8. Dirt, water, or stale fuel is in fuel system. 9. There is incorrect fuel in the fuel tank. 10. The oil level in the crankcase is low. 	<ol style="list-style-type: none"> 1. Fill the fuel tank. 2. Open the fuel valve. 3. Move the choke lever to On. 4. Clean or replace the air cleaner element. 5. Install the wire(s) on the spark plug. 6. Install a new, correctly gapped spark plug(s). 7. Replace the fuel filter. 8. Contact an Authorized Service Dealer. 9. Drain the tank and replace the fuel with the proper type. 10. Add oil to the crankcase.

Problem	Possible Cause	Corrective Action
The engine loses power.	<ol style="list-style-type: none"> 1. The engine load is excessive. 2. The air cleaner is dirty. 3. The oil level in the crankcase is low. 4. The cooling fins and air passages under the engine blower housing are plugged. 5. The spark plug(s) is pitted, fouled, or the gap is incorrect. 6. The vent in the fuel cap is closed. 7. There is dirt in the fuel filter. 8. Dirt, water, or stale fuel is in the fuel system. 9. There is incorrect fuel in the fuel tank. 	<ol style="list-style-type: none"> 1. Reduce ground speed. 2. Clean the air cleaner element. 3. Add oil to the crankcase. 4. Remove the obstruction from the cooling fins and air passages. 5. Install a new, correctly gapped spark plug(s). 6. Open the vent in the fuel cap. 7. Replace the fuel filter. 8. Contact an Authorized Service Dealer. 9. Drain the tank and replace the fuel with the proper type.
The machine does not drive.	<ol style="list-style-type: none"> 1. The traction belts are worn, loose, or broken. 2. The traction belts are off of the pulleys. 	<ol style="list-style-type: none"> 1. Contact an Authorized Service Dealer. 2. Contact an Authorized Service Dealer.
There is abnormal vibration.	<ol style="list-style-type: none"> 1. The engine mounting bolts are loose. 2. The engine pulley, idler pulley, or blade pulley is loose. 3. The engine pulley is damaged. 4. The cutting blade(s) is/are bent or unbalanced. 5. A blade mounting bolt is loose. 6. A blade spindle is bent. 	<ol style="list-style-type: none"> 1. Tighten the engine mounting bolts. 2. Tighten the appropriate pulley. 3. Contact an Authorized Service Dealer. 4. Install a new cutting blade(s). 5. Tighten the blade mounting bolt. 6. Contact an Authorized Service Dealer.

Problem	Possible Cause	Corrective Action
Uneven cutting height.	<ol style="list-style-type: none"> 1. The blade(s) is not sharp. 2. A cutting blade(s) is/are bent. 3. The mower is not level. 4. An anti-scalp wheel is not set correctly. 5. The underside of the mower is dirty. 6. The tire pressure is incorrect. 7. A blade spindle is bent. 	<ol style="list-style-type: none"> 1. Sharpen the blade(s). 2. Install a new cutting blade(s). 3. Level the mower from side-to-side and front-to-rear. 4. Adjust the anti-scalp wheel height. 5. Clean the underside of the mower. 6. Adjust the tire pressure. 7. Contact an Authorized Service Dealer.
The blades do not rotate.	<ol style="list-style-type: none"> 1. The drive belt is worn, loose or broken. 2. The drive belt is off of the pulley. 3. The mower belt is worn, loose, or broken. 	<ol style="list-style-type: none"> 1. Install a new drive belt. 2. Install the drive belt and check the adjusting shafts and belt guides for the correct position. 3. Install a new mower belt.

Schematics

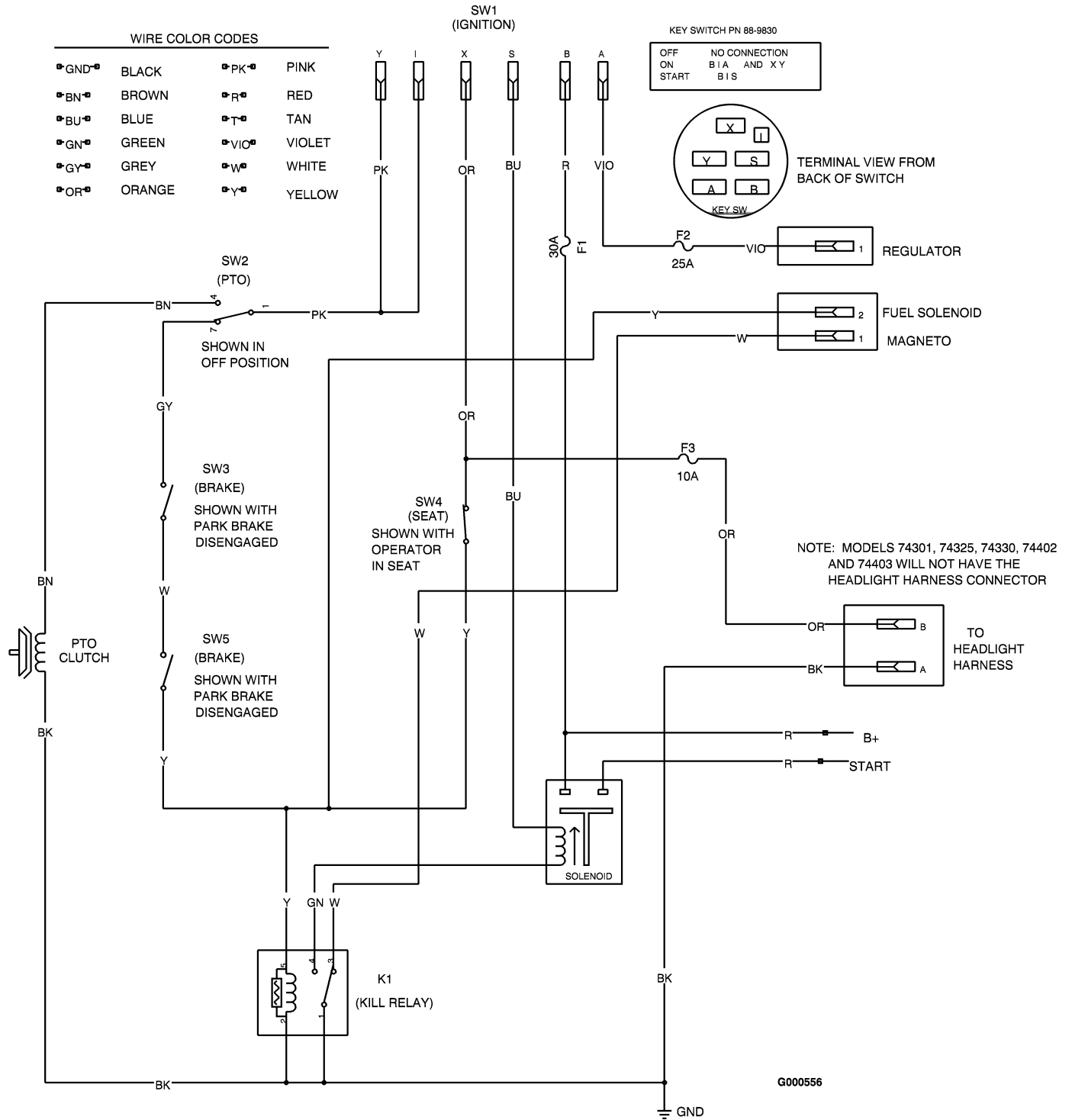

Electrical Diagram (Rev. A)



Count on it.