

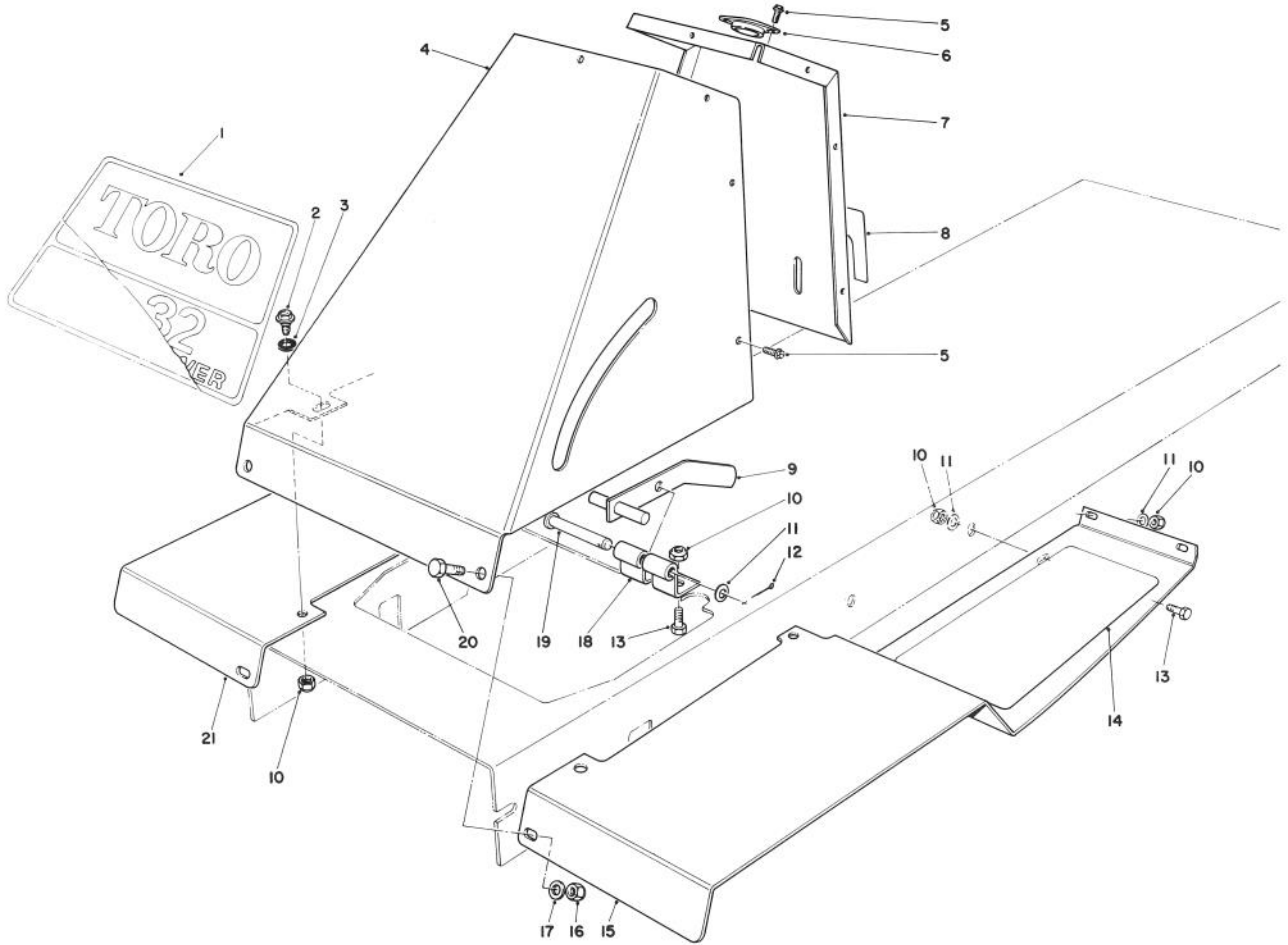

MODEL NO. 56150-600001 & UP
 MODEL NO. 56170-600001 & UP

**PARTS
 CATALOG**

**8 H.P. & 11 H.P. PROFESSIONAL
 REAR ENGINE RIDERS — ELECTRIC**



FRONT TOWER ASSEMBLY

Ref. No.	Part No.	Description	No. Used
1	56-7850	Decal — Toro 832	1
*	53-8080	Decal — Toro 1132	1
2	5-2490	Bolt — Shoulder	4
3	3-3287	Spacer — Rubber	4
4	56-7130	Tower — Front	1
5	32104-76	Screw — Self Tap Acorn Head	9
6	56-7170	Guide — Steering Shaft	1
7	56-7140	Tower — Rear	1
8	56-7810	Decal — Parking Brake	1
9	47-1290	Parking Brake	1
10	3296-29	Nut — Lock	14

Ref. No.	Part No.	Description	No. Used
11	3256-23	Washer — Flat Plain	9
12	3272-6	Cotter Pin	1
13	322-3	Capscrew	6
14	47-1440	Tread — Foot	2
15	47-0940	Footrest — L.H.	1
16	32152-4	Nut — Lock	2
17	3256-22	Washer — Plain	2
18	47-2060	Bracket — Parking Brake	1
19	283-52	Clevis Pin	1
20	321-3	Capscrew	2
21	47-0930	Footrest — R.H.	1

* Not Illustrated

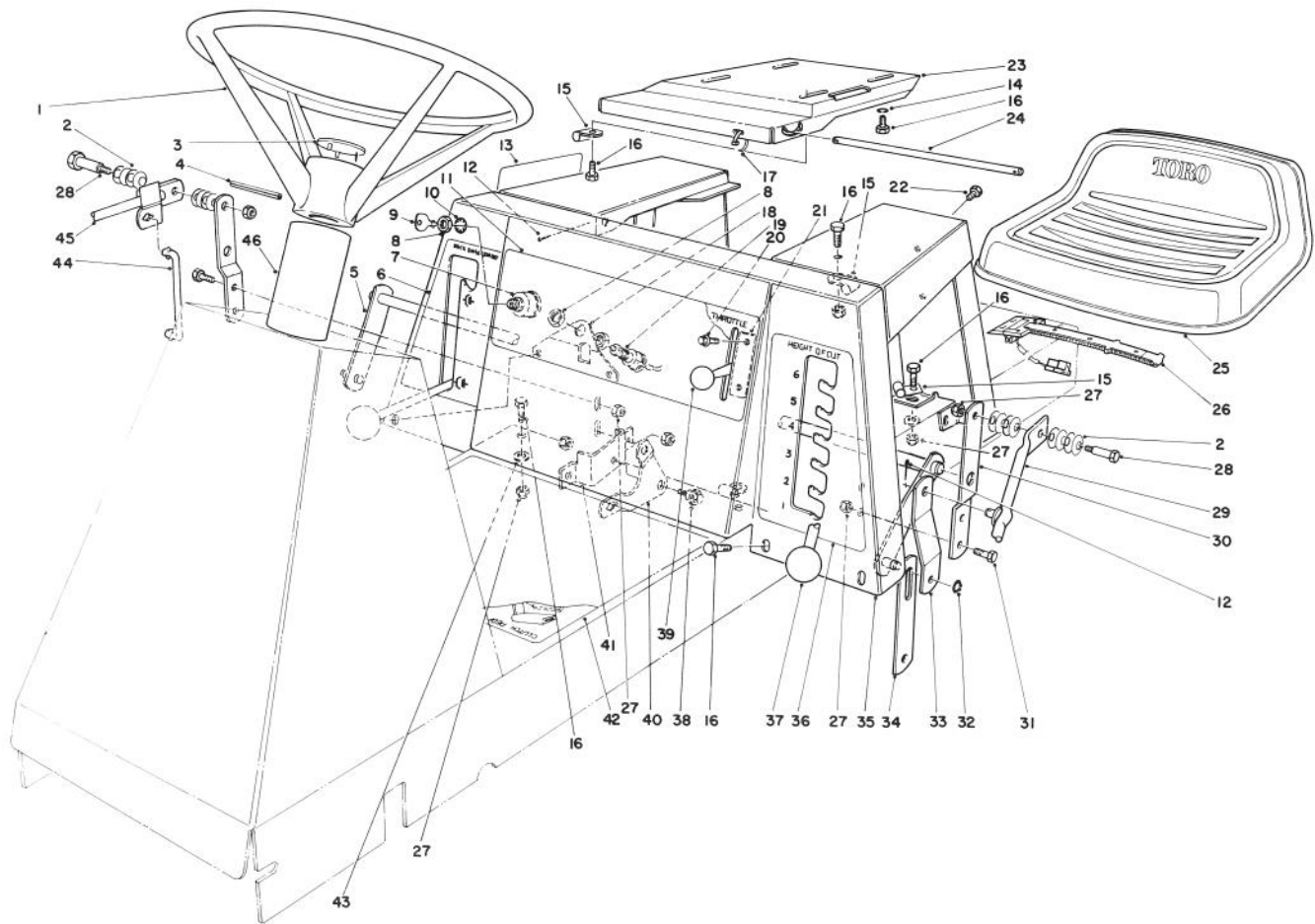

SEAT & STEERING WHEEL ASSEMBLY

Ref. No.	Part No.	Description	No. Used
1	49-3240	Steering Wheel Assembly (Incl. Ref. #3)	1
2	3290-413	Washer — Belleville	16
3	47-2070	Insert — Steering Wheel	1
4	32121-78	Pin — Roll	1
5	56-7400	Lever Arm — Height-of-Cut	1
6	56-7840	Decal — Deck Engage	1
7	23-0660	Switch — Ignition (Incl. Ref. #8-10)	1
8	218-461	Nut — Lock	3
9	218-412	Key — Set of 2	1
10	3254-5	Washer — Lock	1
11	56-7820	Decal — Ignition & Throttle	1
12	3272-6	Pin — Cotter	3
13	44-7260	Decal — Shift Pattern	1
14	3253-4	Washer — Lock	3
15	2412-68	Clamp — Wire	4
16	322-3	Screw — Hex. Hd.	15
17	3290-378	Cable Tie	1
18	56-7150	Bracket — Switch Mount	1
19	56-7640	Switch — Deck (Incl. Ref. #8)	1
20	32104-76	Screw — Self Tapping Acorn Head	2
21	56-7220	Throttle Control (Incl. Ref. #39)	1
22	321-3	Screw — Hex. Hd.	2

Ref. No.	Part No.	Description	No. Used
23	56-7200	Base — Seat	1
24	56-7210	Rod — Seat Base	1
25	38-0840	Seat Assembly	1
26	38-1420	Switch — Seat	1
27	3296-29	Nut — Lock	10
28	28-0540	Bolt — Shoulder	2
29	47-1850	Lever — Height-of-Cut	1
30	47-1840	Bracket — Height-of-Cut	2
31	322-5	Screw — Hex. Hd.	5
32	32151-61	Ring — Retaining	2
33	56-7360	Bracket — Height-of-Cut Engagement	1
34	56-7370	Link — Deck Suspension	2
35	56-7300	Body Assembly	1
36	56-7830	Decal — Height-of-Cut	1
37	233-48	Knob	2
38	19-1470	Bolt — Shoulder	1
39	233-25	Knob	1
40	56-7540	Bell Crank — Deck Engage	1
41	56-7550	Bracket — Bell Crank	1
42	56-7800	Decal — Instructions	1
43	3256-23	Washer — Flat	7
44	56-7560	Link — Bell Crank	1
45	56-7250	Lift Arm Assembly	1
46	47-1980	Cover — Steering Shaft	1

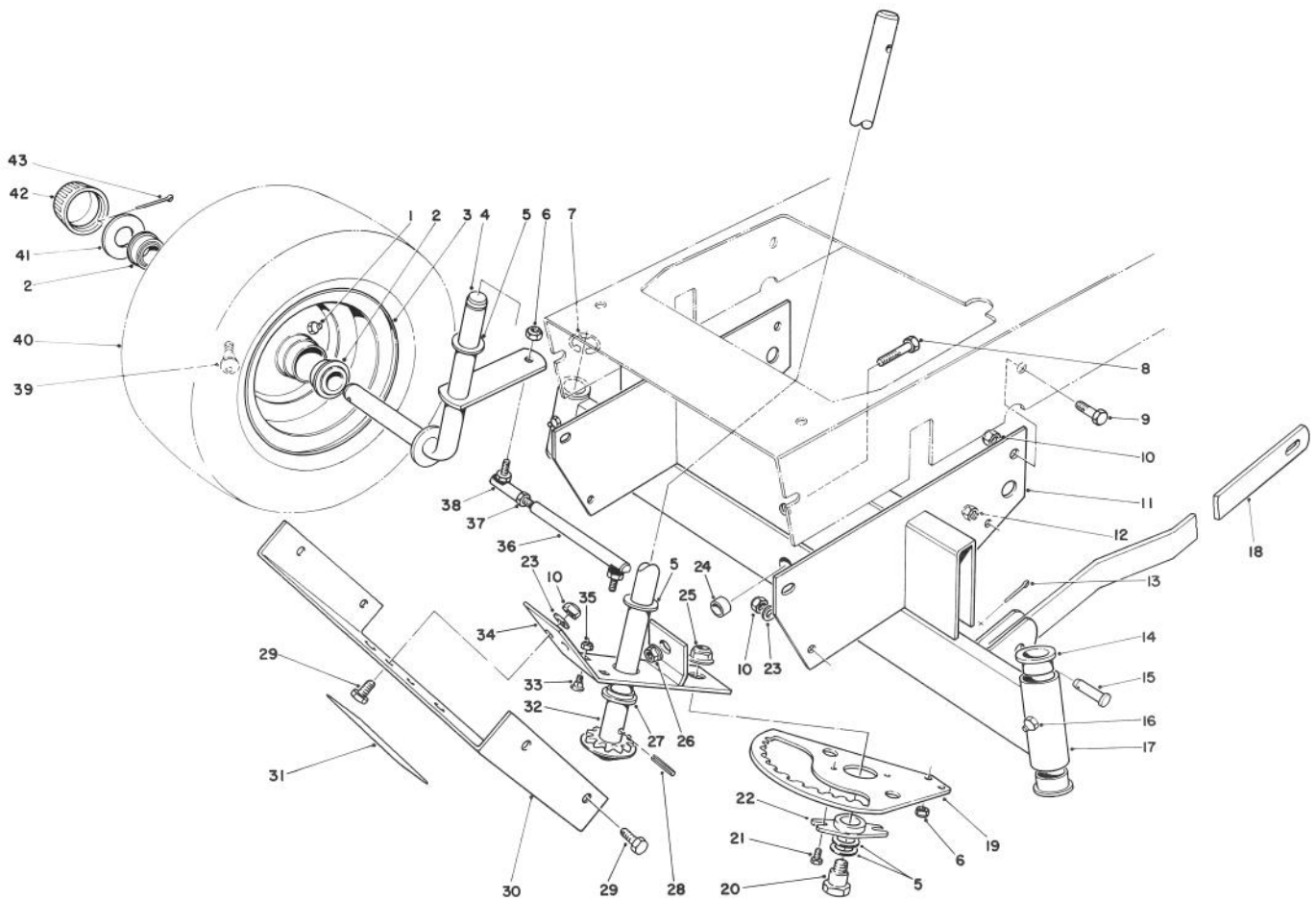

FRONT AXLE ASSEMBLY

Ref. No.	Part No.	Description	No. Used
1	302-5	Grease Fitting	2
2	251-210	Bearing	4
3	217-80	Rim	2
4	47-0600	Spindle — R.H.	1
*	47-0590	Spindle — L.H.	1
5	3-6498	Washer — Thrust	5
6	3296-4	Nut — Lock	4
7	32151-48	Ring — Retaining External	2
8	325-6	Capscrew	1
9	322-2	Capscrew	2
10	3296-29	Nut — Lock	8
11	47-0760	Axle Support	1
12	32152-4	Nut — Lock	1
13	3272-6	Pin — Cotter	2
14	27-9080	Flange Bearing	4
15	283-2	Pin — Clevis	2
16	302-49	Grease Fitting	2
17	47-0980	Axle — Front (Incl. Ref. #14 & 16)	1
18	47-0010	Arm — Front Deck Suspension	2
19	56-7510	Rack — Steering	1
20	56-7530	Bolt — Shoulder	1
21	12-3270	Screw — Special	2
22	56-7520	Bushing — Sector	1

Ref. No.	Part No.	Description	No. Used
23	3256-23	Washer — Plain	6
24	28-0380	Spacer — Front Axle	1
25	32128-21	Nut — Flange Lock	1
26	32128-23	Nut — Lock	1
27	47-0700	Bearing — Flange	1
28	32121-9	Pin — Roll	1
29	322-4	Screw — Cap Hex. Hd.	6
30	56-7180	Cover — Front	1
31	26-4830	Decal — Warning	1
32	56-7500	Shaft — Steering	1
33	3229-2	Bolt — Carriage	2
34	56-7470	Rack — Bracket Steering (Incl. Ref. #27)	1
35	32152-4	Nut — Lock	2
36	47-0610	Tie Rod — Steering (Incl. Ref. #37 & 38)	2
37	3220-2	Jam Nut	2
38	2411-32	Ball Joint	2
39	232-27	Valve Stem w/Cap	2
40	231-116	Tire	2
41	28-2480	Washer	2
42	28-0060	Hub Cap	2
43	3272-12	Pin — Cotter	2
†	232-44	Inner Tube	2

* Not Illustrated
 † Service Replacement Part

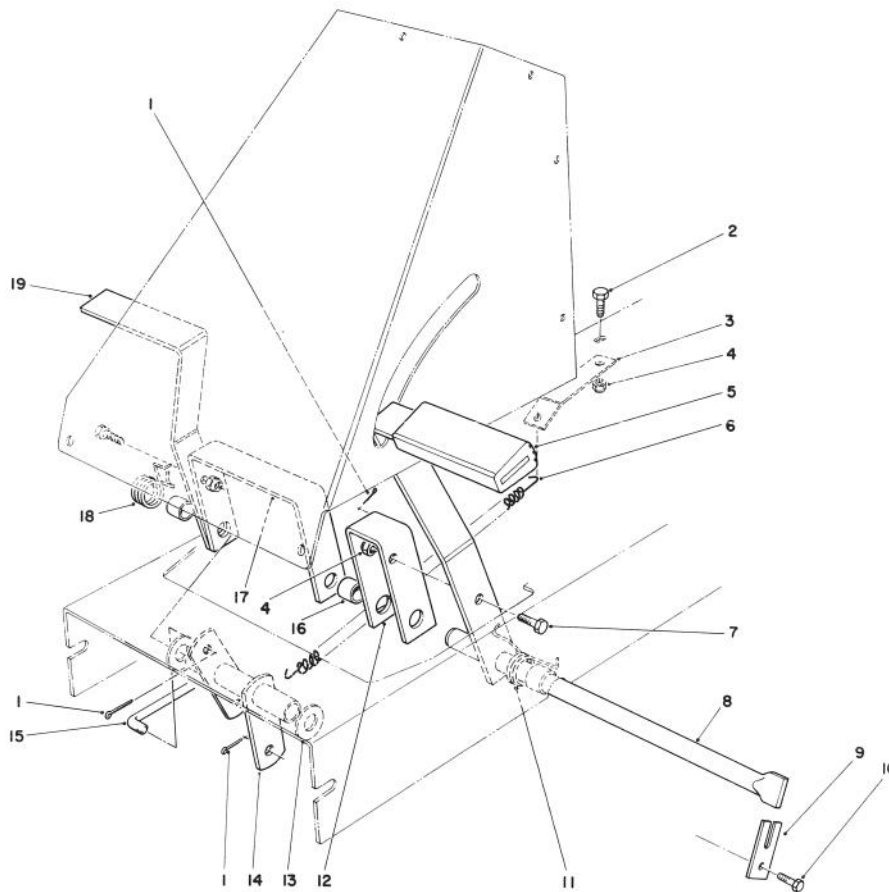

BRAKE & CLUTCH ASSEMBLY

Ref. No.	Part No.	Description	No. Used
1	3272-6	Cotter Pin	3
2	322-3	Screw — Cap Hex. Hd.	1
3	56-7240	Bracket — Spring Retaining	1
4	3296-29	Nut — Lock	3
5	47-1570	Pad — Foot Pedal	2
6	27-8960	Spring — Extension	1
7	322-5	Capscrew	2
8	47-0770	Shaft — Pedal Pivot	1
9	47-0780	Retainer — Shaft	1
10	321-3	Capscrew	1

Ref. No.	Part No.	Description	No. Used
11	56-7070	Spring Torsion (Clutch)	1
12	47-0560	Bracket — Clutch Pedal	1
13	3256-27	Washer — Plain	2
14	56-7650	Tube — Pivot	1
15	56-7570	Rod — Engagement	1
16	47-0570	Spacer — Pedal	3
17	47-0550	Bracket — Brake Pedal	1
18	56-7080	Spring — Torsion (Brake)	1
19	47-0540	Pedal	2

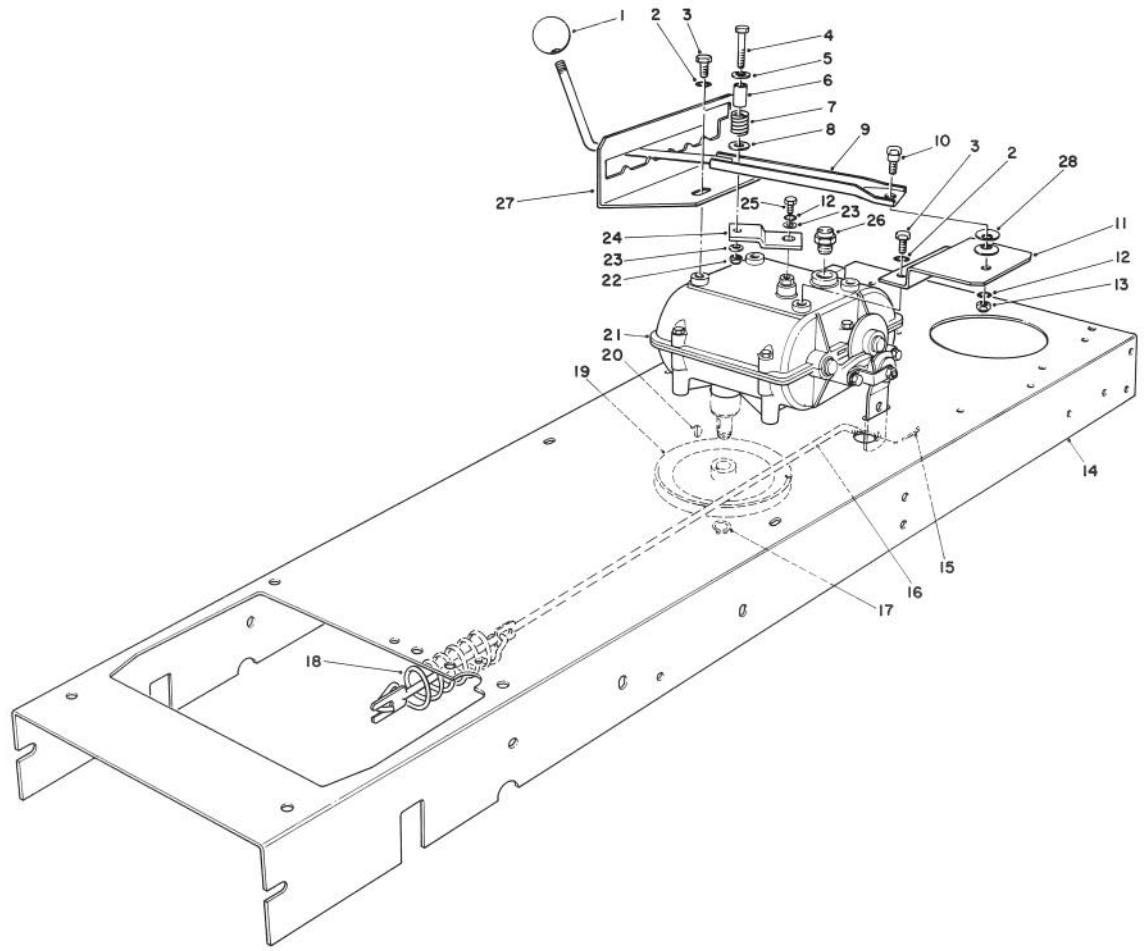

TRANSMISSION LINKAGE ASSEMBLY

Ref. No.	Part No.	Description	No. Used
1	233-48	Knob	1
2	3253-4	Washer — Lock	4
3	32144-11	Screw — Thread Forming	4
4	321-15	Screw — Cap Hex. Hd.	1
5	3256-55	Washer — Fender	1
6	56-7740	Spacer — Split	1
7	56-7730	Spring — Compression	1
8	3256-4	Washer — Plain	1
9	56-7600	Lever — Shift	1
10	19-1470	Bolt — Shoulder	1
11	56-7610	Bracket — Shift Mounting	1
12	3253-3	Lockwasher	2
13	3296-29	Nut — Lock	1
14	56-7160	Frame — Main	1

Ref. No.	Part No.	Description	No. Used
15	3272-6	Pin — Cotter	1
16	56-7060	Rod — Brake	1
17	32120-64	Retainer — Ring External	1
18	27-8950	Spring — Extension	1
19	7-4085	Pulley — Transmission	1
20	3257-5	Key — Woodruff	1
21	47-1530	Transmission	1
22	32152-4	Nut — Lock	1
23	3256-22	Washer — Plain	2
24	56-7620	Lever — Shift	1
25	329-4	Capscrew	1
26	28-4250	Switch — Neutral Start	1
27	56-7630	Gate — Shift	1
28	3290-413	Washer — Belleville	2

TRANSMISSION MODEL 770A

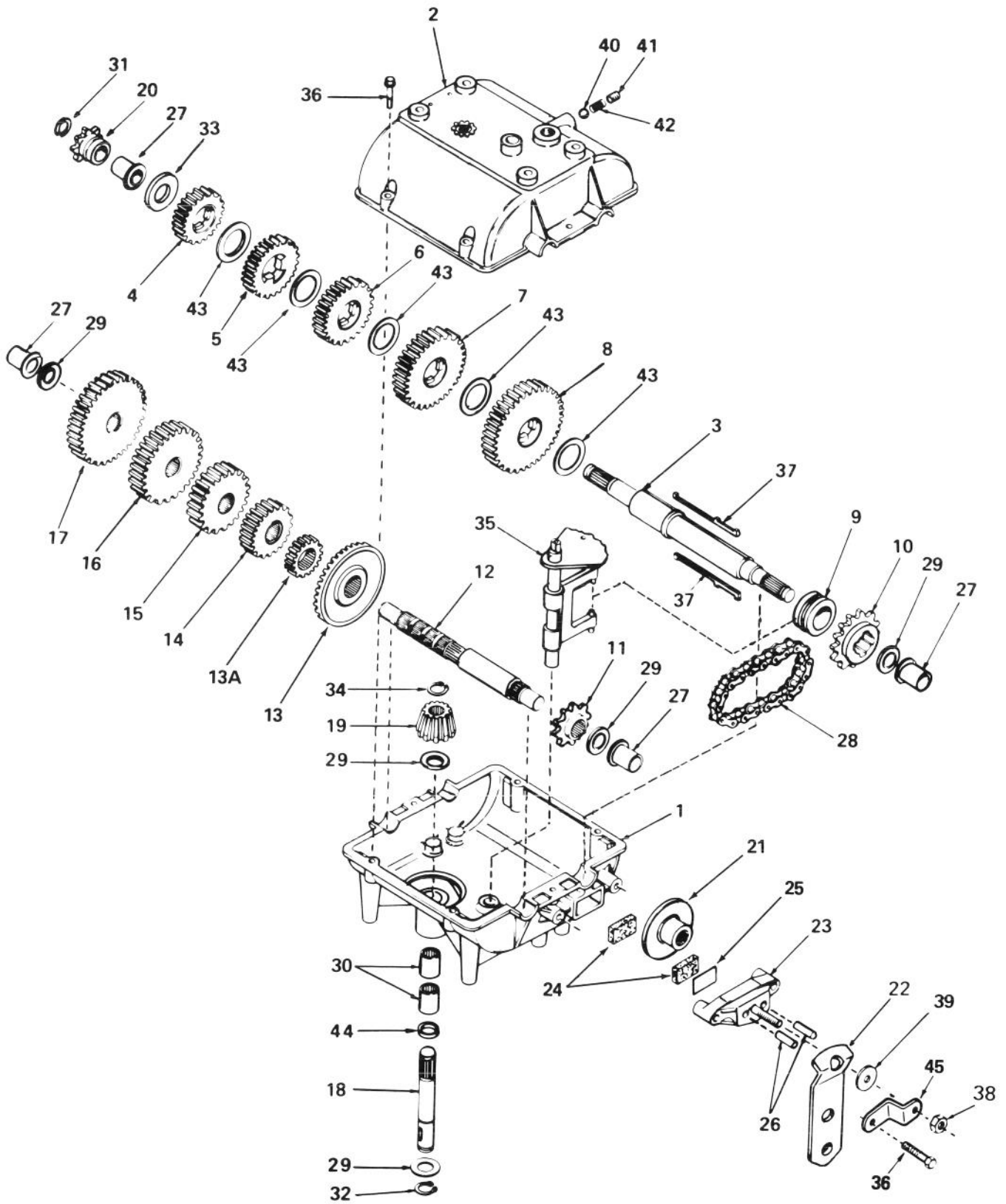

TRANSMISSION MODEL 770A

Ref. No.	Part No.	Description	No. Used
1	770061	Case — Transmission	1
2	772083	Cover — Transmission	1
3	776161	Shaft — Output & Brake	1
4	778121A	Gear — Spur (20 teeth)	1
5	778122A	Gear — Spur (22 teeth)	1
6	778123A	Gear — Spur (25 teeth)	1
7	778124A	Gear — Spur (30 teeth)	1
8	778125	Gear — Spur (35 teeth)	1
9	784266	Collar — Shift	1
10	786083	Sprocket (18 teeth)	1
11	786082	Sprocket (9 teeth)	1
12	776134	Shaft — Counter	1
13	778137A	Gear — Bevel (42 teeth)	1
13A	778136	Gear — Spur (15 teeth)	1
14	778126A	Gear — Spur (20 teeth)	1
15	778127A	Gear — Spur (25 teeth)	1
16	778128A	Gear — Spur (28 teeth)	1
17	778129A	Gear — Spur (30 teeth)	1
18	776135	Shaft — Input	1
19	778113A	Bevel Pinion — Input	1
20	786048	Sprocket (8 teeth)	1
21	790003	Disk — Brake	1
22	790013	Lever — Brake	1
23	790025	Holder — Brake Pad	1

Ref. No.	Part No.	Description	No. Used
24	790006	Pad — Brake	1
25	790007	Plate — Brake Pad	1
26	786026	Pin — Dowel	1
27	780105A	Bushing — Flanged	1
28	786081	Chain Roller (No. 41 chain, 24 links)	1
29	780072	Race — Thrust	1
30	780086	Bearing — Needle	1
31	792072	Ring — Retaining	1
32	792035	Ring — Retaining	1
33	780109	Washer	1
34	788040	Ring — Retaining	1
35	784267	Rod & Fork Assy. — Shift	1
36	792073	Screw — Hex. Hd.	1
37	792089A	Key	1
38	792075	Nut — Lock	1
39	792076	Washer — Flat	1
40	792077	Ball — Steel	1
41	792078	Screw — Set	1
42	792079	Spring	1
43	780108	Washer — Thrust	1
44	792001	Ring — Square Cut	1
45	786086	Bracket — Brake Lever	1

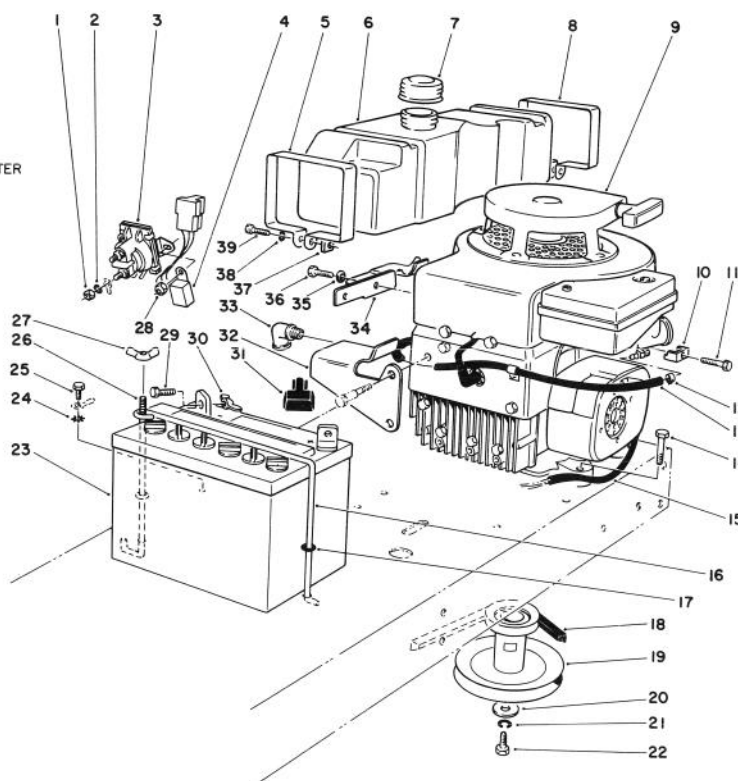
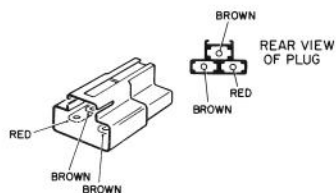
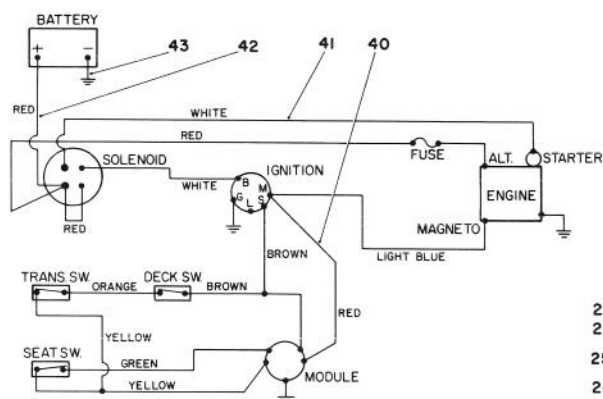

ENGINE ASSEMBLY

Ref. No.	Part No.	Description	No. Used
1	3218-1	Nut — Hex. Jam	2
2	3253-2	Washer — Lock	2
3	47-1910	Solenoid	1
4	39-6520	Module — Interlock	1
5	57-4060	Retainer — Tank (Front)	1
6	56-7050	Tank — Fuel (5 qt.)	1
7	55-3570	Cap — Fuel Tank	1
8	57-4070	Retainer — Tank (Rear)	1
9	56-7780	Engine — 8 H.P. (Model 56150)	1
*	56-7790	Engine - 11 H.P. (Model 56170)	1
10	2210-249	Clamp — Casing	1
11	2210-248	Screw — Hex. Hd.	1
12	2210-185	Clamp — Fuel Line	2
13	47-2986	Line — Fuel	1
14	322-7	Screw — Cap Hex. Hd.	4
15	57-4150	Cover — Protective	1
16	56-7710	Hold Down — Battery	1
17	237-143	O-Ring	2
18	47-1410	Belt — Traction Drive	1
19	47-1960	Pulley — Engine	1
20	3256-25	Washer — Flat	1
21	3253-22	Washer — Lock	1
22	3212-5	Screw — Cap Hex. Hd.	1

Ref. No.	Part No.	Description	No. Used
23	56-7700	Battery	1
24	3254-2	Washer — Lock	1
25	32104-82	Screw — Hex. Hd. Self Tapping	1
26	56-7720	Post — Battery	1
27	32103-12	Nut — Wing	1
28	32152-4	Nut — Lock	2
29	321-3	Screw — Hex. Hd.	2
30	32103-22	Nut — Wing	2
31	28-8080	Boot — Terminal	1
32	57-4040	Bracket — Tank (Front)	1
33	2811-10	Elbow — 90° Street	1
34	57-4050	Bracket — Tank (Rear)	1
35	3256-23	Washer — Flat	2
36	322-4	Screw — Hex. Hd.	2
37	32107-11	Nut — Square	2
38	3253-3	Washer — Lock	2
39	3274-51	Screw — Hex. Hd.	2
40	56-7690	Wiring Harness	1
41	56-7660	Wiring Harness — Starter	1
42	56-7670	Cable — Battery Positive	1
43	56-7870	Cable — Battery Negative	1
*	3290-378	Cable Tie	1

* Not Illustrated

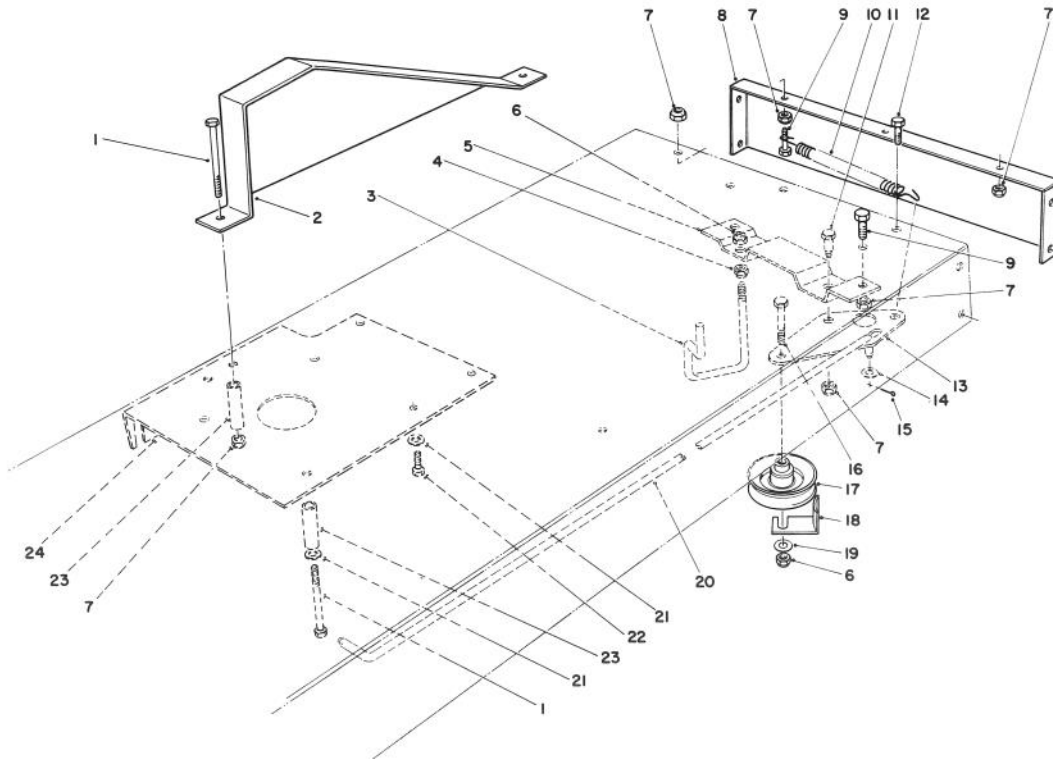

TRACTION ASSEMBLY

Ref. No.	Part No.	Description	No. Used
1	322-11	Screw — Cap Hex. Hd.	2
2	47-1220	Guard — Chain	1
3	47-0500	Guide — Belt	1
4	32153-2	Locknut	1
5	47-0471	Bracket — Traction Support	1
6	32152-2	Nut — Lock	2
7	3296-29	Nut — Lock	8
8	47-0730	Frame — Rear	1
9	322-7	Capscrew	3
10	27-8960	Spring — Extension	1
11	37-8770	Screw — Shoulder	1
12	322-3	Capscrew	2

Ref. No.	Part No.	Description	No. Used
13	47-0481	Bracket — Traction Pivot	1
14	3256-22	Washer — Plain	1
15	3272-6	Pin — Cotter	1
16	323-9	Screw — Cap Hex. Hd.	1
17	12-5820	Pulley — Idler	1
18	12-9020	Retainer — Belt	1
19	3256-24	Washer — Plain	1
20	47-0490	Rod — Traction	1
21	3256-23	Washer	4
22	32140-45	Screw — Machine Hex. Hd.	3
23	47-0920	Spacer — Outer Tube	2
24	47-1950	Plate — Reinforcement	1

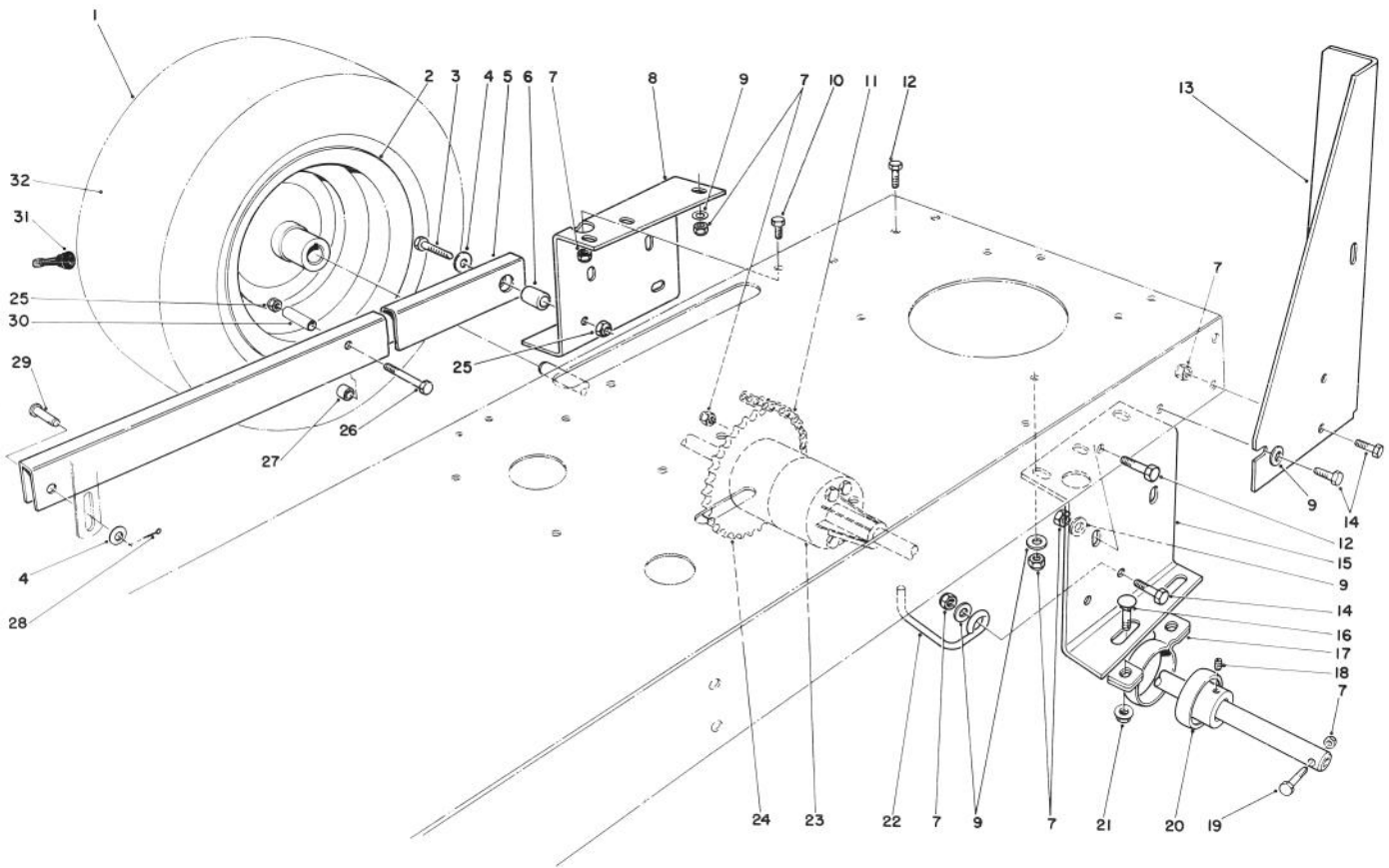

REAR AXLE ASSEMBLY

Ref. No.	Part No.	Description	No. Used
1	231-117	Tire	2
2	242-78	Rim	2
3	323-9	Screw — Hex. Hd.	2
4	3256-24	Washer — Plain	4
5	47-0020	Arm — Rear Deck Suspension	2
6	56-7430	Pin — Arm Support	2
7	3296-29	Nut — Lock	17
8	56-7410	Support — Rear Axle R.H.	1
9	3256-23	Washer — Plain	8
10	322-3	Screw — Hex. Hd.	1
11	56-7230	Chain	1
12	322-4	Screw — Cap Hex. Hd.	4
13	56-7450	Standbar — L.H.	1
*	56-7440	Standbar — R.H.	1
14	322-5	Capscrew — Hex. Hd.	7
15	56-7420	Support — Rear Axle L.H.	1
16	3231-30	Bolt — Carriage	4
17	47-1480	Retainer — Pillow Block	2

Ref. No.	Part No.	Description	No. Used
18	3245-35	Set Screw 1/4-28	4
*	3246-15	Set Screw 5/16-18	4
19	322-9	Screw — Hex. Hd.	2
20	47-1490	Bearing — Self Aligning (Incl. Ref. #18)	2
21	32128-21	Nut — Lock Flange	4
22	47-2010	Belt Guide — Engine Pulley	1
23	56-7120	Differential	1
24	56-7090	Sprocket Differential	1
25	32152-2	Nut — Lock	4
26	323-13	Screw — Cap Hex. Hd.	2
27	47-0910	Spacer — Inner Tube	2
28	3272-6	Cotter Pin	2
29	283-42	Pin — Clevis	2
30	47-0920	Spacer — Outer Tube	2
31	232-27	Valve Stem w/Cap	2
32†	232-39	Inner Tube	2

* Not Illustrated

† Service Replacement Part

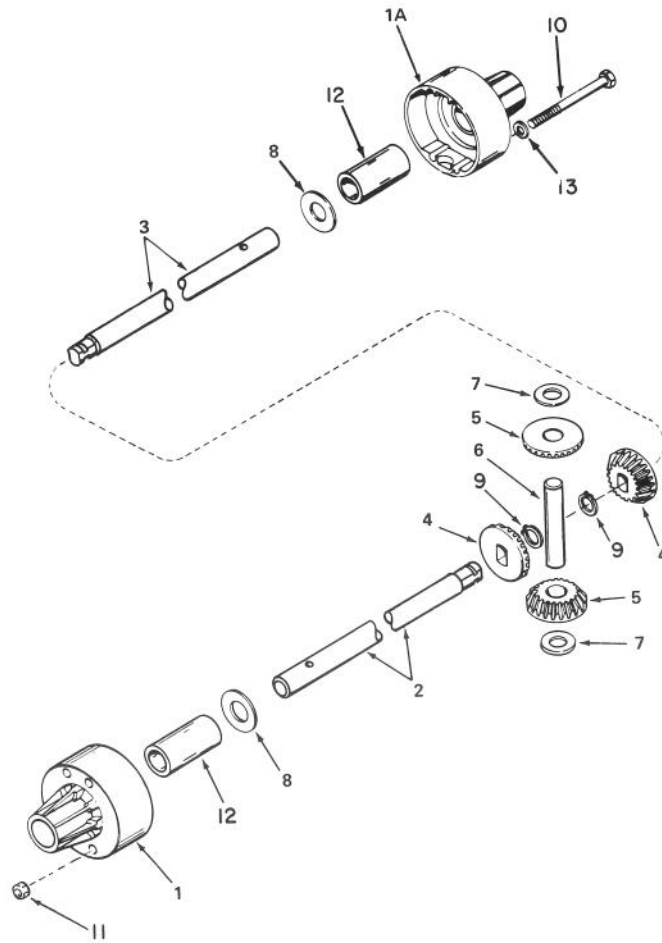

DIFFERENTIAL MODEL 100-050

Ref. No.	Part No.	Description	No. Used
1	774344	Housing — Differential Carrier (Incl. #13)	1
1A	774345	Housing — Differential Carrier (Incl. #13)	1
2	774661	Axle (10-1/4" long)	1
3	774662	Axle (18-7/8" long)	1
4	778067	Gear — Bevel	1
5	778068	Gear — Pinion	1

Ref. No.	Part No.	Description	No. Used
6	786040	Pin — Drive	1
7	780096	Washer — Thrust	1
8	780001	Washer — Sprocket	1
9	792018	Ring — Snap	1
10	792041	Screw — Hex. Hd.	1
11	792042	Nut — Lock	1
12	780077	Bushing	1
13	792061	Washer	1

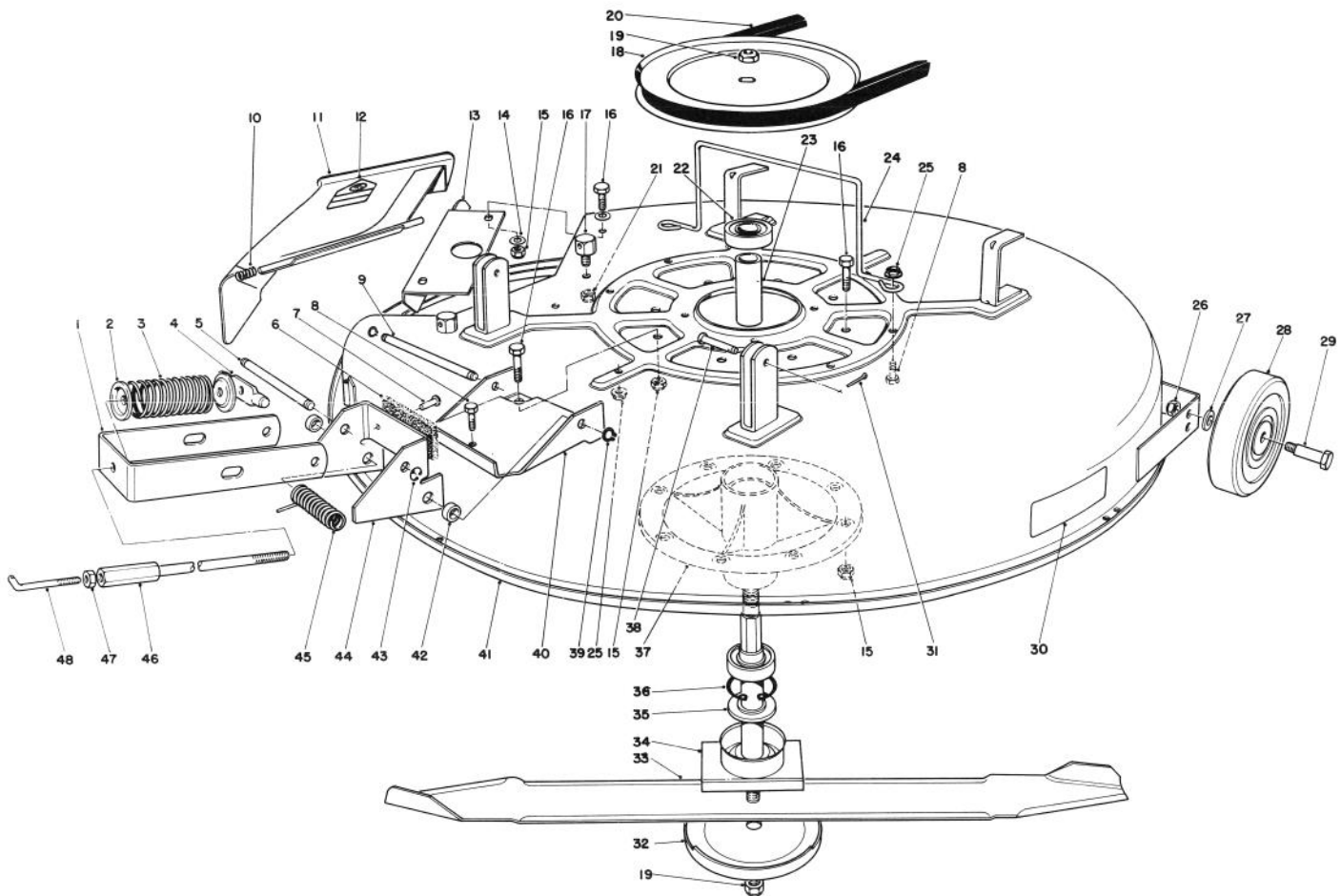

MOWER ASSEMBLY

Ref. No.	Part No.	Description	No. Used
1	47-1180	Bracket — Engagement	1
2	47-1140	Retainer — Spring Top	2
3	47-0960	Spring — Compression	1
4	47-1200	Shaft — Adjusting	1
5	47-1230	Pin — Clevis	1
6	47-0210	Pad — Brake	1
7	3295-43	Rivet	2
8	321-4	Cap screw	3
9	47-1670	Pin — Clevis	1
10	28-8010	Spring — Torsion	1
11	44-5930	Deflector Assembly (Incl. Ref. #12)	1
12	54-9220	Decal — Deflector Caution	1
13	44-5720	Baffle Deck	1
14	3256-23	Washer — Plain	4
15	3296-29	Nut — Lock	10
16	322-4	Cap screw	10
17	28-7350	Pivot Post	1
18	47-1350	Pulley	1
19	17-0980	Nut — Special	2
20	47-1420	V-Belt	1
21	32153-2	Nut — Lock	1
22	251-297	Bearing	2
23	47-0100	Spacer — Bearing	1
24	57-4210	Guide — Belt	2

Ref. No.	Part No.	Description	No. Used
25	32128-10	Nut — Locking Flange	3
26	3296-39	Nut — Lock	2
27	3256-24	Washer — Plain	2
28	29-6010	Wheel	2
29	56-6590	Wheel Bolt	2
30	47-7240	Decal — Deck	1
31	3272-6	Cotter Pin	2
32	7-3522	Anti-Scalp Cup	1
33	33-4750	Blade	1
34	47-0090	Spindle Shaft	1
35	47-0110	Spacer — Spindle	1
36	32120-11	Ring — Retaining Internal	1
37	56-7030	Spindle Body	1
38	283-2	Pin Clevis	2
39	32151-57	Ring — Retaining External	2
40	47-1240	Channel — Deck Engagement	1
41	47-1600	Cutter Deck	1
42	47-1900	Spacer — Deck Brake Support	2
43	32120-18	Ring — Retaining External	2
44	47-1610	Support Deck Brake Assembly (Incl. Ref. #6 & 7)	1
45	40-6230	Spring — Torsional	1
46	47-1150	Hub — Adjusting	1
47	3218-3	Nut — Jam	1
48	47-1130	Rod — Adjusting	1

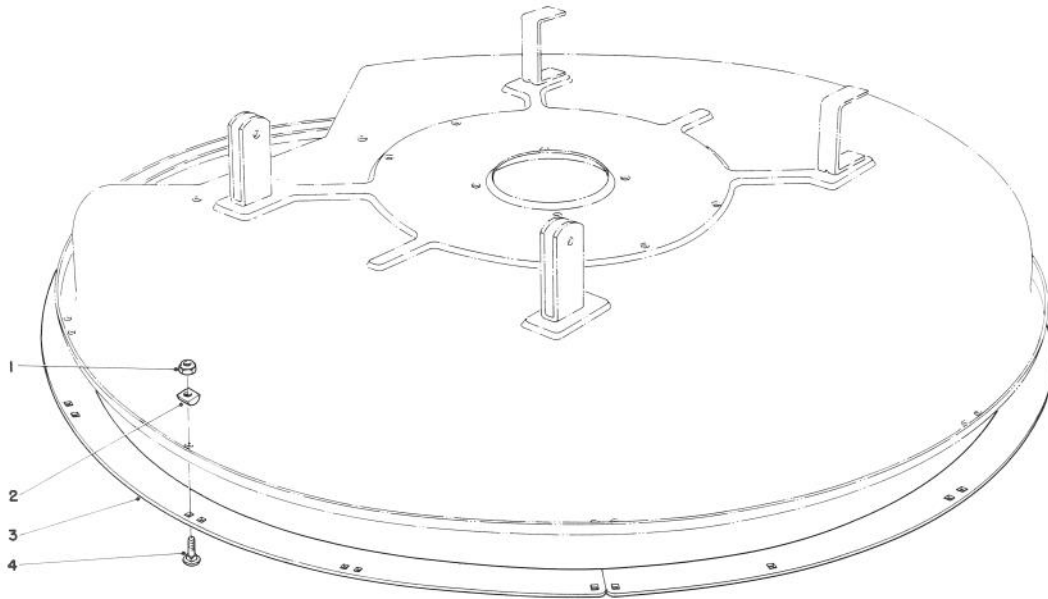

WET GRASS BAGGING KIT NO. 38-5730 (Optional)

Ref. No.	Part No.	Description	No. Used
1	3296-29	Locknut	12
2	56-7880	Spacer — Deck Ring	12

Ref. No.	Part No.	Description	No. Used
3	38-6030	Ring — Deck	4
4	3230-2	Carriage Bolt	12

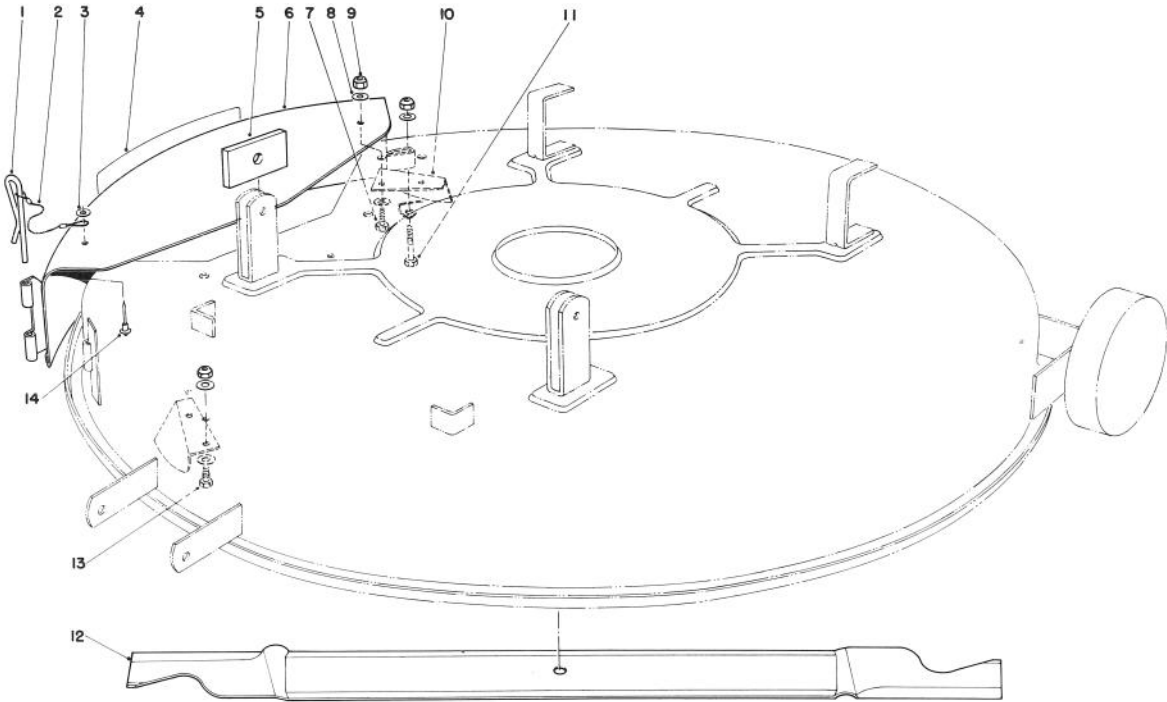

MULCHER KIT MODEL 59155 (Optional)

Ref. No.	Part No.	Description	No. Used
1	28-8130	Pin — Chute Locking	1
2	28-8070	Lanyard	1
3	3256-49	Washer	1
4	44-5910	Decal — Mulcher Cover	1
5	44-5820	Spacer — Deck Angle	2
6	44-5700	Cover — Mulcher Assembly (Incl. Ref. #1-4 & 14)	1
7	322-5	Capscrew — Hex. Head	1

Ref. No.	Part No.	Description	No. Used
8	3256-23	Washer	9
9	3296-29	Locknut	5
10	44-5810	Kicker	2
11	322-10	Capscrew — Hex. Head	1
12	39-3480	Blade — Mulcher	1
13	322-3	Capscrew — Hex. Head	3
14	3290-282	Rivet — Pop	1

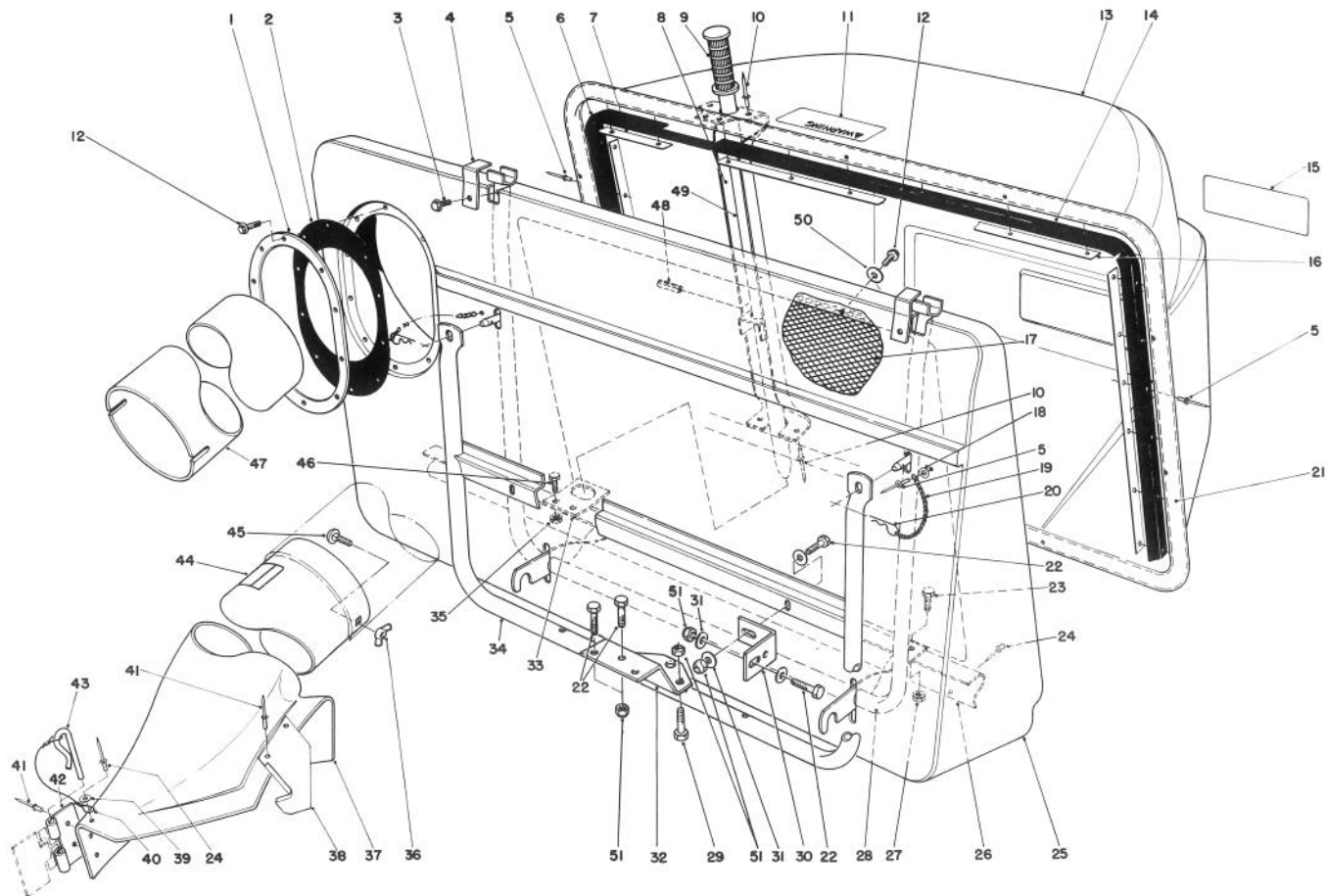

EASY-EMPTY GRASS CATCHER MODEL 59111 (Optional)

Ref. No.	Part No.	Description	No. Used
1	28-7760	Ring — Retainer	1
2	28-7770	Ring — Retainer Rubber	1
3	32104-60	Screw — Hex. Hd. Self Tapping	2
4	28-7700	Retainer Pivot Bracket	2
5	3290-415	Domed Head Rivet	22
6	36-2520	Seal — Bag R.H.	1
7	29-5540	Retainer — Ext. Top	1
8	38-2920	Channel — Dump Handle	1
9	233-40	Grip Handle	1
10	3290-409	Domed Head Rivet	16
11	55-7270	Decal — Warning	1
12	32104-76	Screw — Self Tapping	18
13	36-2120	Grass Basket — Rear	1
14	36-2530	Seal — Bag L.H.	1
15	25-2200	Decal	1
16	29-5550	Retainer — Ext. Bag	3
17	28-7840	Screen — Bag	1
18	5-1254	Washer	2
19	2830-10	Chain	2
20	3290-355	Hair Pin Cotter	2
21	28-7670	Frame — Bag Support	1
22	322-4	Capscrew — Hex. Head	7
23	322-2	Capscrew — Hex. Head	2
24	3290-282	Rivet	6
25	28-7810	Bag Front	1
26	28-7830	Frame Support Bracket	1
27	32152-1	Locknut	2

Ref. No.	Part No.	Description	No. Used
28	28-7710	Bag Frame	1
29	322-7	Capscrew — Hex. Head	4
30	56-7190	Bracket — Mtg. Grass Catcher	2
31	3256-23	Washer — Plain	9
32	51-2970	Bracket — Mtg. Grass Catcher	1
33	28-7820	Hanger — Frame Tower	1
34	28-7780	Bag Support	1
35	32152-4	Locknut	2
36	32103-14	Wing Nut	2
37	28-8060	Chute Assembly (Incl. Ref. #24, 38-44)	1
38	33-2090	Bracket — Chute Support	1
39	3256-49	Washer	1
40	28-8070	Lanyard	1
41	3290-412	Rivet	4
42	28-8050	Bracket — Chute Mounting	1
43	28-8130	Pin — Chute Locking	1
44	54-9220	Decal — Danger	1
45	3229-1	Carriage Bolt	2
46	321-3	Capscrew — Hex. Head	2
47	47-7210	Duct	1
48	32121-79	Roll Pin	1
49	29-5470	Dump Handle	1
50	3256-61	Washer — Fender	8
51	3296-29	Nut — Lock	9
*†	56-6740	Hanger Extension	2

* Not Illustrated

† Service Replacement Part

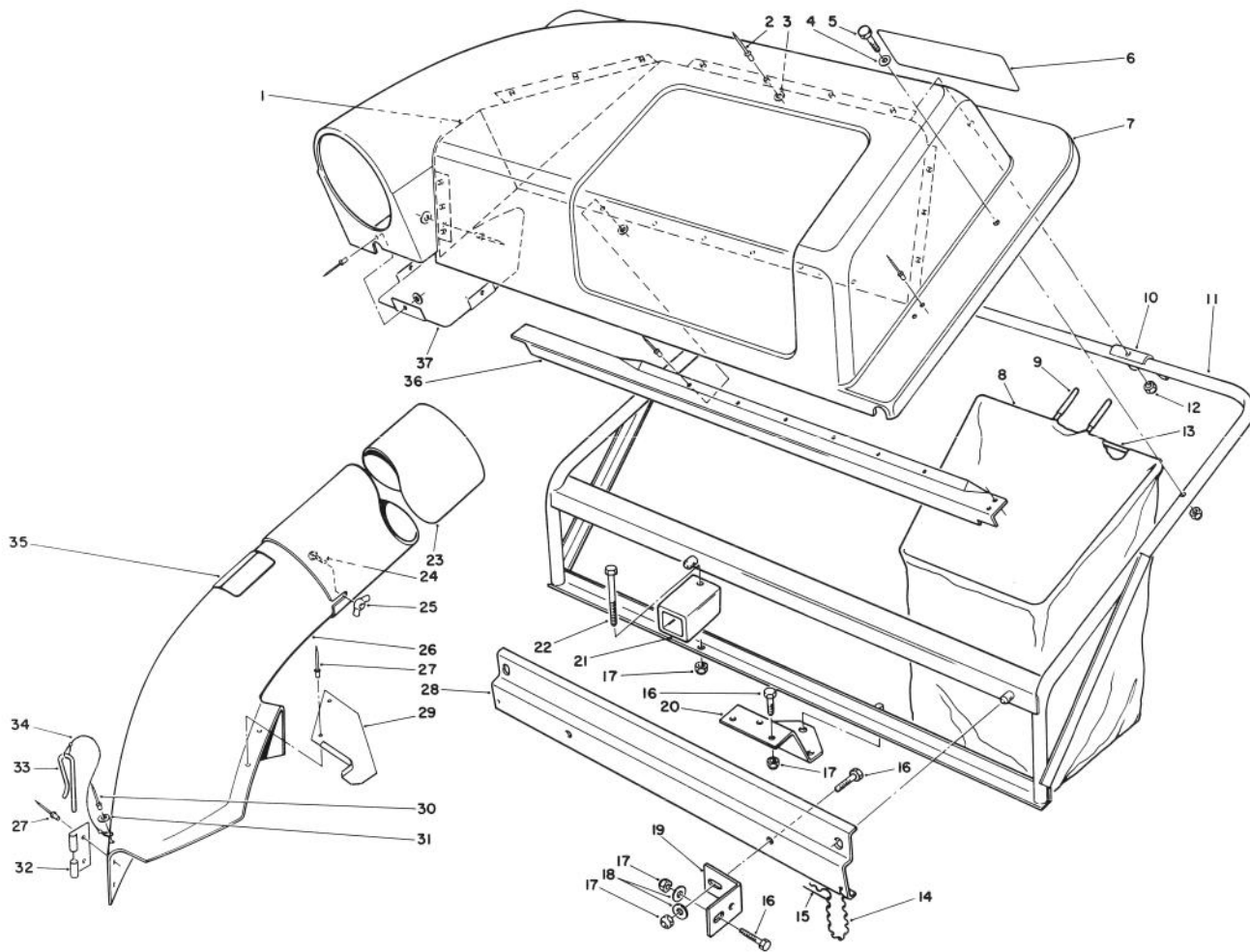

TWIN BAGGER GRASS CATCHER MODEL NO. 59122 (Optional)

Ref. No.	Part No.	Description	No. Used
1	36-4230	Screen — Cover	1
2	3269-4	Rivet — Pop	23
3	3256-14	Washer — Plain	21
4	3256-23	Washer — Plain	4
5	322-7	Screw — Cap Hex. Hd.	4
6	47-6890	Decal — Twin Bagger	1
7	47-2190	Cover	1
8	47-2560	Bag — Twin Bagger (Incl. Ref. #9 & 13)	2
9	47-2550	Grip — Bag Handle	2
10	47-2580	Bracket — Bag Frame	2
11	47-2630	Frame	1
12	32111-8	Nut — Acorn	4
13	47-2620	Frame — Bag	1
14	2830-9	Chain	2
15	3290-355	Hair Pin Cotter	2
16	322-4	Capscrew	7
17	3296-29	Nut — Lock	8
18	3256-23	Washer — Flat	8
19	56-7190	Bracket — Mtg. Grass Catcher	2

Ref. No.	Part No.	Description	No. Used
20	51-2970	Plate — Mtg. Grass Catcher	1
21	51-2960	Tube — Frame Support	1
22	322-10	Screw — Cap Hex. Hd.	1
23	47-7210	Duct	1
24	3229-1	Carriage Bolt	2
25	32103-14	Nut — Wing	2
26	28-8060	Chute Assembly (Incl. Ref. #27, 29-35)	1
27	3290-412	Pop Rivet	4
28	36-4550	Bracket — Frame Support	1
29	33-2090	Bracket Chute Support	1
30	3290-282	Pop Rivet	1
31	3256-49	Washer — Plain	1
32	28-8050	Bracket Chute Mounting	1
33	28-8130	Pin — Chute Locking	1
34	28-8070	Lanyard	1
35	54-9220	Decal — Instruction Chute	1
36	47-2650	Bracket — Screen Support	1
37	47-6760	Shield — Cover	1

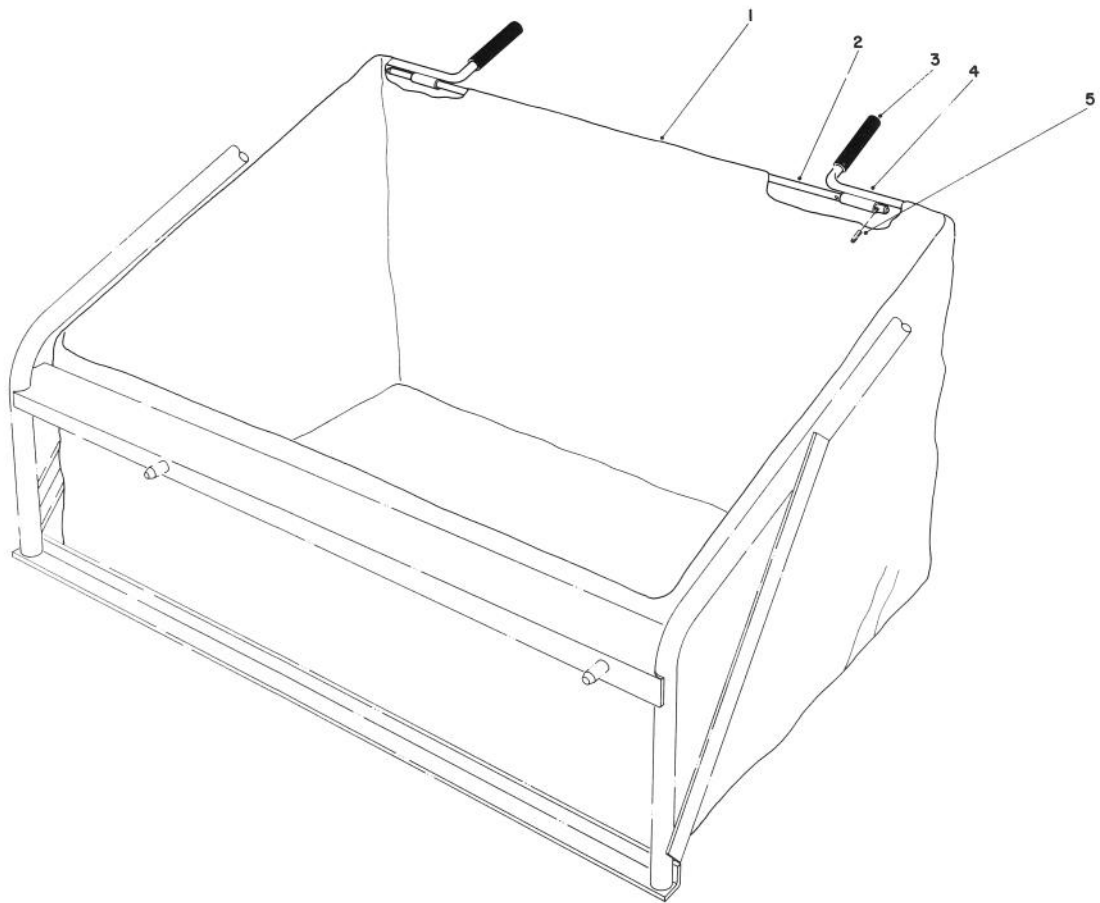

LEAF BAG MODEL NO. 59123 (Optional)

Ref. No.	Part No.	Description	No. Used
1	47-6860	Bag — Leaf Catcher	1
2	47-6800	Rod — Bag Frame	1
3	47-6710	Grip — Leaf Bag Handle	2
4	47-6830	Bag Frame	1

Ref. No.	Part No.	Description	No. Used
5	32121-73	Rollpin	2
*	505-78	Adhesive — Plastic	1
*	47-7550	Bag (Complete)	1

* Not Illustrated

ENGINE 8 H.P. BRIGGS & STRATTON MODEL NO. 193707-0152-01

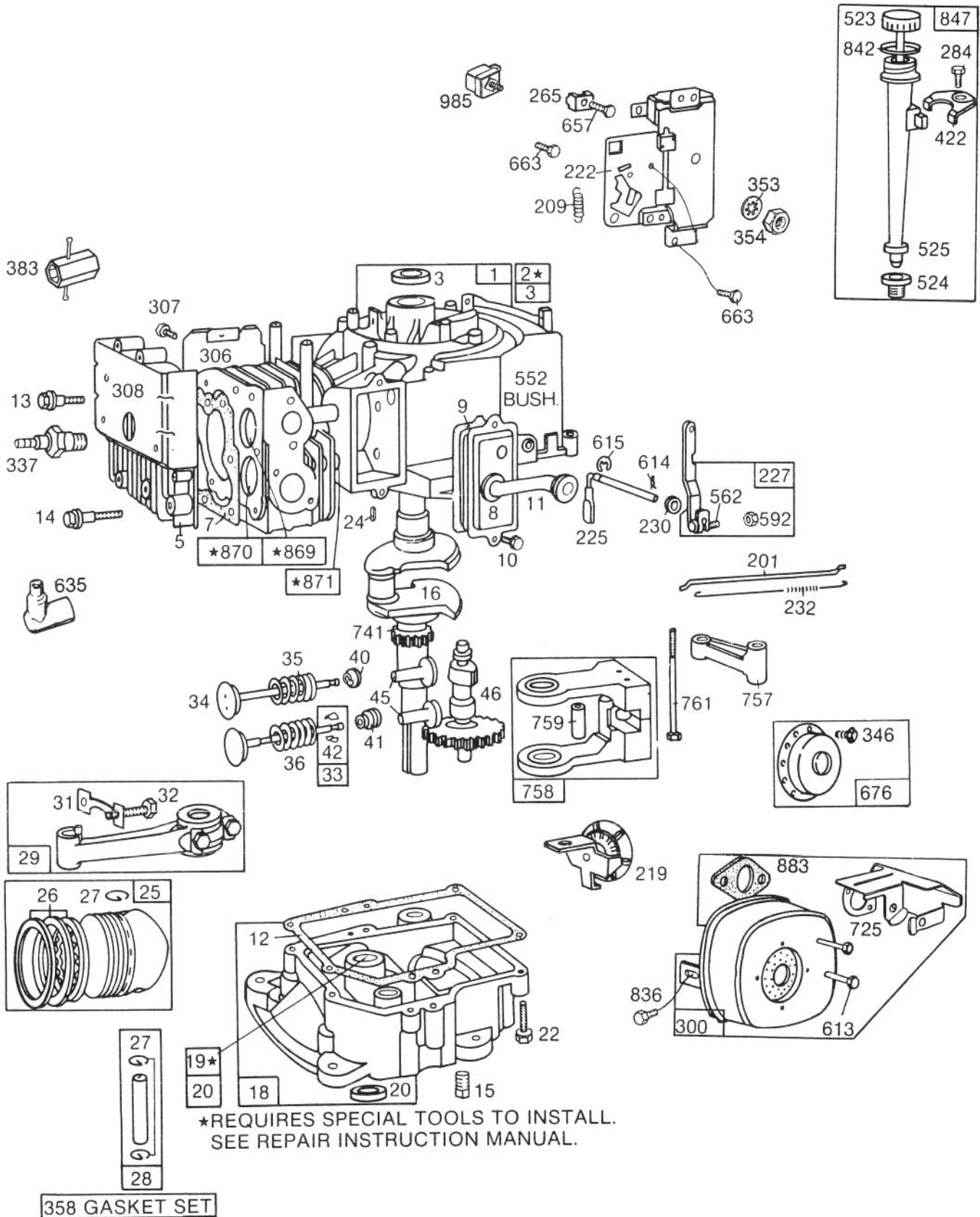

ENGINE 8 H.P. BRIGGS & STRATTON MODEL NO. 193707-0152-01

Ref. No.	Part No.	Description	No. Used
1	397240	Cylinder Assembly	1
2	261960	Bushing — Cylinder	1
3	294606	Seal — Oil	1
5	212286	Head — Cylinder	1
7	*270430	Gasket — Cylinder Head	1
8	391406	Breather Assembly	1
9	*27803	Gasket — Valve Cover	1
10	93394	Screw	1
11	280005	Tube — Breather	1
12	*27750	Gasket — Crankcase Cover 1/64" thick	1
	*27876	Gasket — Crankcase Cover .005" thick	1
	*27877	Gasket — Crankcase Cover .009" thick	1
13	93211	Screw — Cylinder Head (2-21/32" long)	1
14	93723	Screw — Cylinder Head (3" long) 1 Req'd.	1
15	91084	Plug — Oil Drain	1
16	396876	Crankshaft Note: To Replace Crankshaft Gear Pin — Order Part No. 230978	1
18	392548	Base — Engine	1
19	295963	Bushing — Oil Base	1
20	391086	Seal — Oil	1
22	93585	Screw — Base Mounting	1
24	222698	Key — Flywheel	1
25	393868	Piston Assembly — Standard	1
	393869	Piston Assembly — .010" O.S.	1
	393879	Piston Assembly — .020" O.S.	1
	393880	Piston Assembly — .030" O.S. Piston Ring Sets: Note: For Chrome Piston Ring Set — Standard Size Order No. 299743	1
26	393881	Ring Set — Piston — Std.	1
	393882	Ring Set — Piston — .010" O.S.	1
	393883	Ring Set — Piston — .020" O.S.	1
	393884	Ring Set — Piston — .030" O.S.	1
27	68546	Lock — Piston Pin	1
28	295840	Pin Assembly — Piston — Standard	1
	295841	Pin Assembly — Piston — .005" O.S.	1
29	390402	Rod Assy. — Connecting Note: For Connecting Rod with .020" Undersize Crankpin Bore — Order No. 390773	1
31	222114	Lock — Connecting Rod Screw	1
32	92659	Screw — Connecting Rod	1
33	390420	Valve — Exhaust	1
34	261055	Valve — Intake	1
35	65906	Spring — Intake Valve	1
36	26828	Spring — Exhaust Valve	1
40	221596	Retainer — Intake Valve	1
41	292260	Rotocoil — Exhaust Valve	1

Ref. No.	Part No.	Description	No. Used
42	93630	Retainer — Exhaust Valve Rotocoil	2
45	260933	Tappet — Valve	1
46	211689	Gear — Cam	1
201	261611	Link — Governor	1
209	260871	Spring — Governor	1
219	392718	Oil Slinger — Gov. Gear and Bracket Assembly	1
222	390784	Plate — Gov. Control	1
225	231058	Crank — Governor (1/4" Dia.)	1
227	391733	Lever Assy. — Governor For 1/4" Dia. Crank	1
230	222450	Washer — Gov. Lever (1/4" I.D.)	1
232	261911	Spring — Governor Link	1
265	221535	Clamp — Casing	1
284	93804	Screw — Clamp Mtg.	1
300	398507	Muffler — Exhaust	1
306	222830	Shield — Cylinder	1
307	93163	Screw — Cylinder Shield Mtg.	1
308	222636	Cover — Cylinder Head	1
337	293918	Plug — Spark (1-1/2" high — 37 M.M.) (Resistor Type)	1
346	93705	Screw	1
353	92791	Washer — Lock — Shakeproof	1
354	90576	Nut — Hex.	1
358	299577	Gasket Set	1
383	89838	Wrench — Spark Plug	1
422	222502	Clamp — Oil Filler Tube	1
523	391840	Cap and Dipstick — Oil Filler	1
524	68838	Seal — Filler Tube	1
525	280133	Tube — Oil Filler	1
552	231055	Bushing — Gov. Crank (1/4" I.D.)	1
562	92613	Bolt — Governor Lever	1
592	231082	Nut — Hex.	1
613	94042	Screw — Muffler Mtg.	1
614	93306	Cotter — Hair Pin	1
615	93307	Retainer — E-Ring	1
635	66538	Elbow — Spark Plug	1
657	93496	Screw	1
663	93572	Screw	1
676	395700	Deflector — Exhaust	1
725	223450	Shield — Muffler	1
741	261195	Gear — Timing	1
757	212359	Link — Counterweight	1
758	390172	Counterweight Assy.	1
759	298909	Pin — Counterweight	1
761	93874	Screw — Counterweight	1
836	93559	Screw	1
842	270920	Seal — Filler Cap	1
847	392066	Filler Group — Oil	1
869	211661	Seat — Intake Valve (Standard)	1
870	211661	Seat — Exhaust Valve (Standard)	1
871	261961	Guide — Exhaust Valve Note: 231218 Guide — Intake Valve (Brass) See Repair Manual	1
883	270918	Gasket — Exhaust Pipe	1
985	398525	Insulator Assembly	1

* Included in Gasket Set — Part No. 299577.

ENGINE 8 H.P. BRIGGS & STRATTON MODEL NO. 193707-0152-01 (Continued)

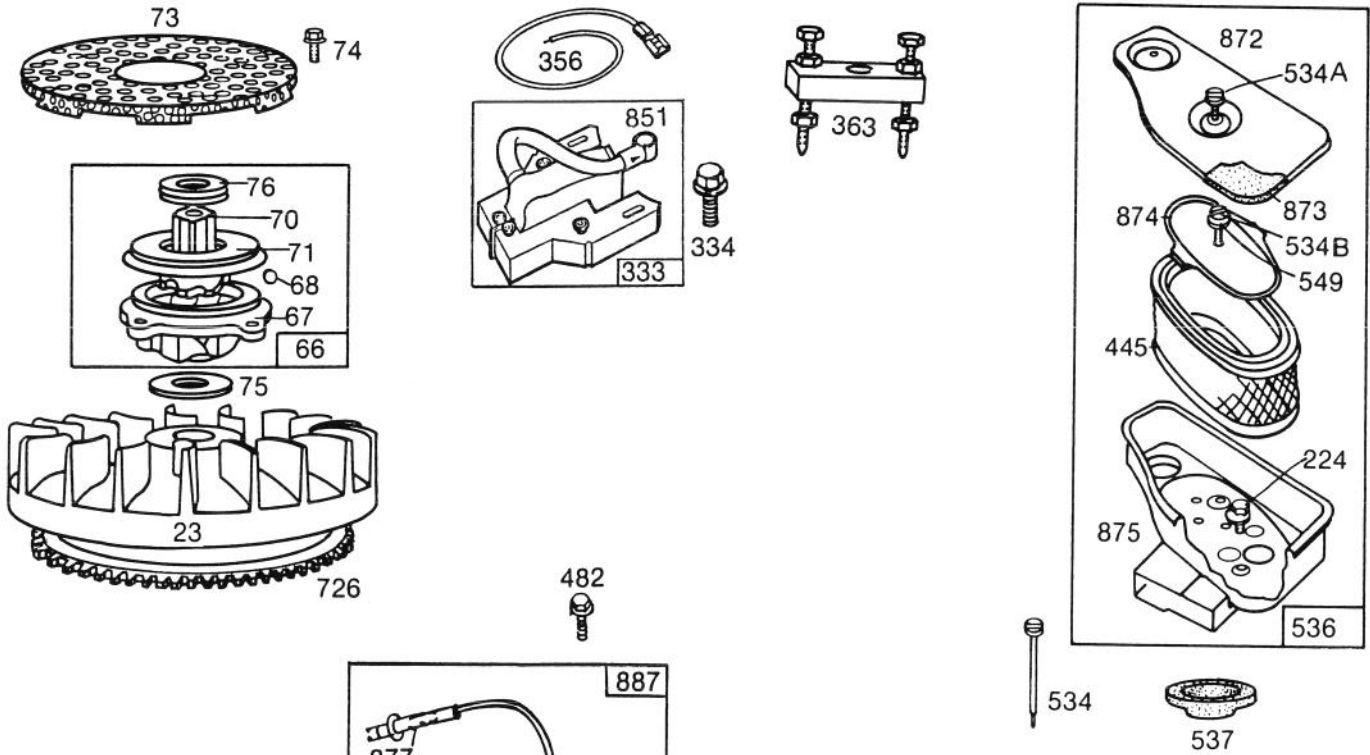

121 CARBURETOR OVERHAUL KIT

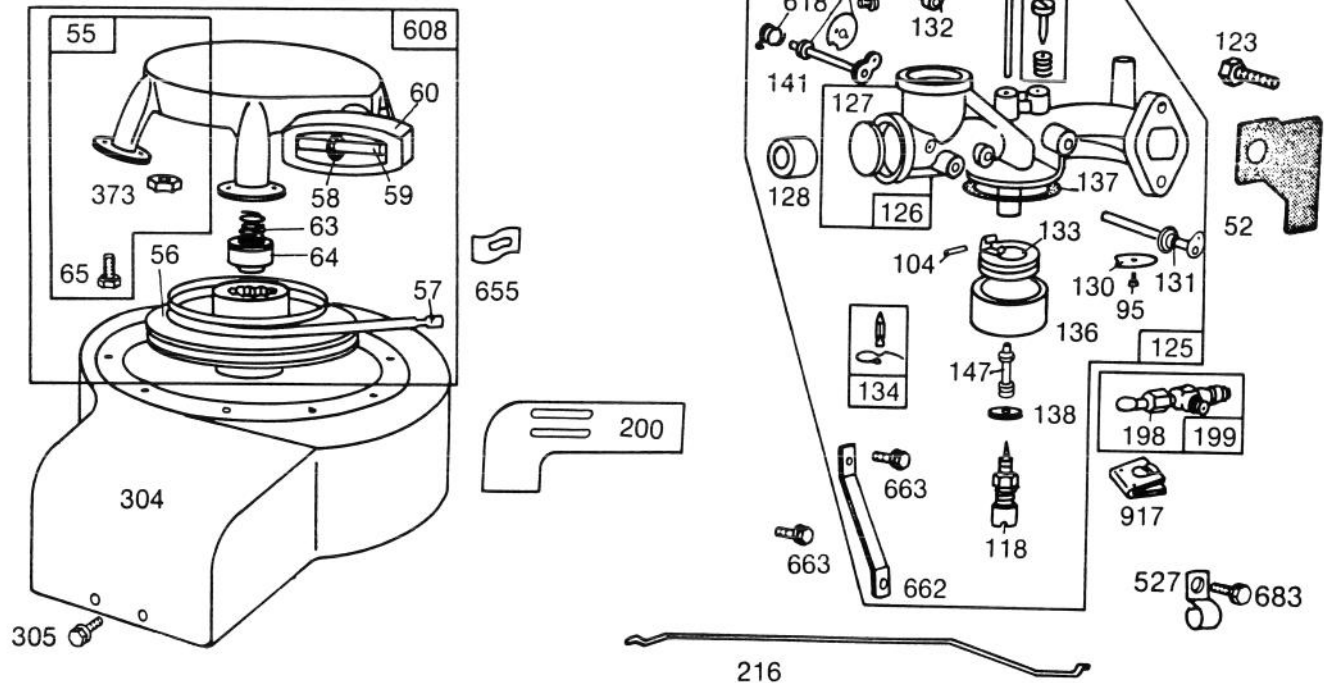

ENGINE 8 H.P. BRIGGS & STRATTON MODEL NO. 193707-0152-01 (Continued)

Ref. No.	Part No.	Description	No. Used
23	391983	Flywheel and Ring Gear Assy. — Magneto For use on engines WITH ALTERNATOR. (Includes aluminum ring gear.)	1
52	*270824	Gasket — Carburetor Mounting	1
55	393576	Housing — Rewind Starter	1
56	295871	Pulley — Rewind Starter Note: Includes 63" Rope; if longer Rope is required, Order Rope No. 66894 and cut to required length.	1
57	294303	Spring — Rewind Starter	1
58	66884	Rope — Rewind Starter — 63" long; if longer Rope is needed, Order No. 66894 and cut to required length.	1
59	230228	Pin — Starter Grip	1
60	66728	Grip — Starter Rope	1
63	260414	Spring — Ratchet	1
64	230543	Adapter — Ratchet Spring	1
65	94128	Screw — Rewind Starter Housing Mtg.	1
66	394558	Clutch Assembly — Rewind Starter	1
67	394897	Housing — Rewind Starter Clutch	1
68	63770	Ball — Clutch	1
70	298799	Ratchet — Rewind Starter Clutch	1
71	221653	Washer — Retainer	1
73	221796	Screen — Rewind Starter	1
74	93042	Screw	1
75	220865	Washer — Spring	1
76	68238	Washer — Ratchet Sealing	1
94	†292681	Valve Assembly — Carburetor Idle	1
95	93499	Screw — Throttle and Choke Valve Mtg.	1
98	91920	Screw — Machine, Fill. Hd.	1
99	26157	Spring — Throttle Adjustment	1
101	93043	Pin — Throttle Stop	1
104	†230896	Pin — Float Hinge	1
108	222010	Valve — Choke	1
118	†396568	Valve — Needle	1
121	394698	Carburetor Overhaul Kit	1
123	93357	Screw — Carburetor Mtg.	1
125	390811	Carburetor Assembly (Choke-A-Matic)	1
126	299851	Body Assembly Carburetor	1
127	†221997	Plug — Welch	1
128	211682	Venturi — Carburetor	1

Ref. No.	Part No.	Description	No. Used
130	221986	Valve — Throttle	1
131	391512	Shaft and Lever — Throttle	1
132	211712	Stop — Throttle	1
133	299707	Float — Carburetor	1
134	†394681	Valve — Fuel Inlet	1
136	221995	Bowl — Float	1
137	†270511	Gasket — Float Bowl	1
138	†222014	Washer — Float Bowl	1
141	390684	Shaft and Lever — Choke	1
142	†299740	Nozzle — Carburetor	1
147	†231323	Screw — Nozzle	1
198	293934	Valve — Fuel Shut-Off	1
199	390303	Connector — Fuel Pipe	1
200	221760	Guide — Air	1
216	261612	Link — Choke	1
224	94018	Screw	1
304	391379	Housing — Blower	1
305	93158	Screw — Blower Housing Mounting	1
333	398811	Armature — Magneto	1
334	93381	Screw — Armature Mounting	1
356	398808	Wire — Ground	1
363	19165	Puller — Flywheel	1
373	92987	Nut — Hex.	1
445	393406	Cartridge — Air Cleaner	1
482	93621	Screw	1
527	221428	Clamp	2
534	93323	Screw — Air Cleaner	1
534A	93913	Screw — Air Cleaner	1
534B	93881	Screw — Air Cleaner	1
536	393481	Cleaner Assy. — Air	1
537	270539	Gasket — Air Cleaner	1
549	270978	Washer — Air Cleaner	1
608	390391	Starter Assy. — Rewind	1
618	261116	Spring — Choke Return	1
634	270382	Washer — Choke Shaft	1
655	222598	Anchor — Spring	1
662	222027	Bracket — Carburetor	1
663	93572	Screw	1
683	93572	Screw	1
726	392134	Gear — Ring (Aluminum) (Includes Mtg. Parts)	1
851	221798	Terminal — Ignition Cable	1
872	222897	Cover — Air Cleaner	1
873	271171	Gasket — Air Cleaner Cover	1
874	222898	Plate — Air Cleaner Cartridge	1
875	393828	Body — Air Cleaner	1
877	393814	Diode and Connector Assy. (Dual Circuit)	1
887	391529	Stator Assembly — Alternator (Dual Circuit)	1
917	223271	Valve Handle — Fuel Shut-Off	1

* Included in Gasket Set — Part No. 299577.

† Included in Carburetor Overhaul Kit — Part No. 394698.

ENGINE 11 H.P. BRIGGS & STRATTON MODEL NO. 253707-0195-01

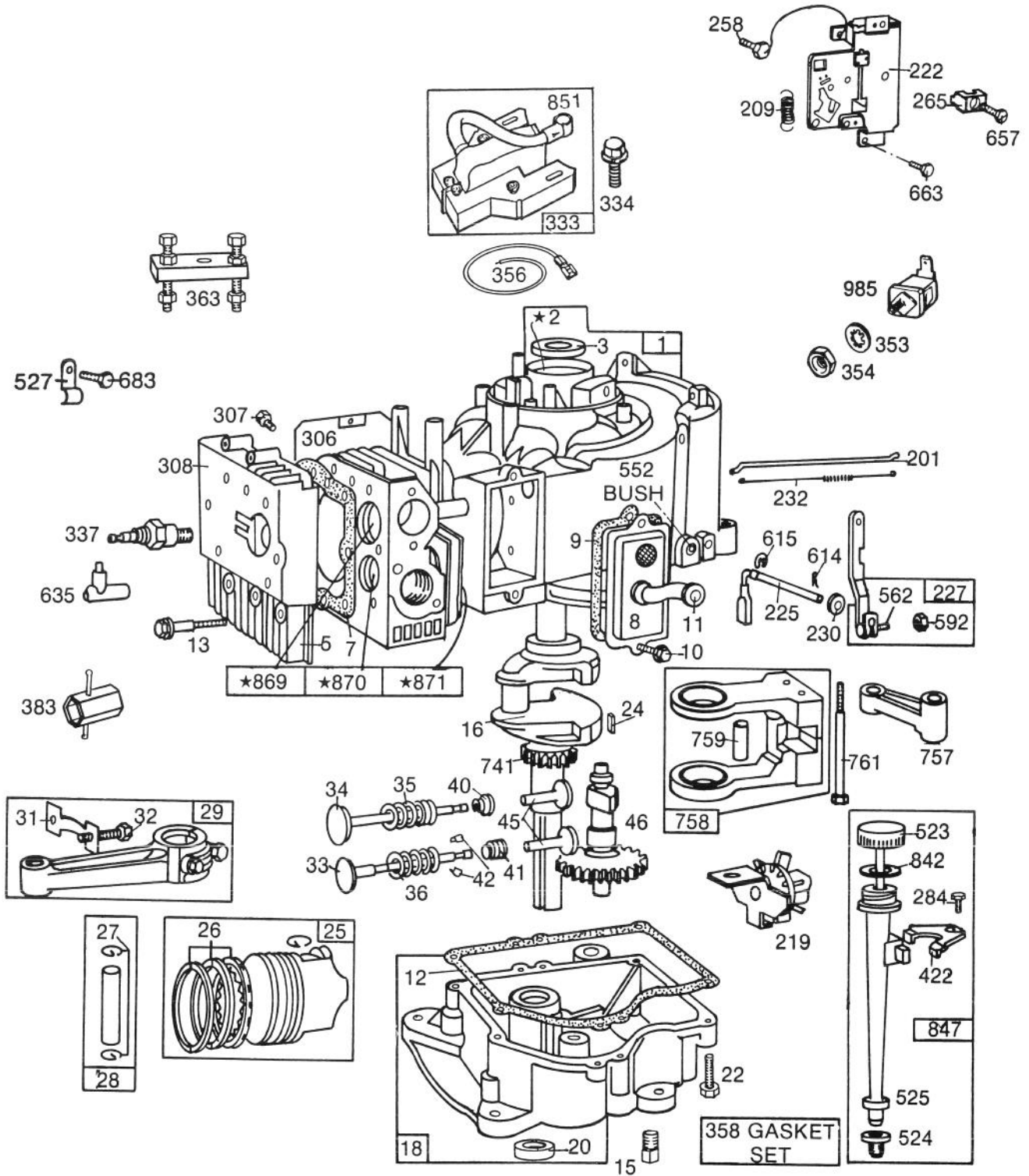

★REQUIRES SPECIAL TOOLS TO INSTALL.
SEE REPAIR INSTRUCTION MANUAL.

ENGINE 11 H.P. BRIGGS & STRATTON MODEL NO. 253707-0195-01

Ref. No.	Part No.	Description	No. Used
1	395705	Cylinder Assembly	1
2	261623	Bearing	1
3	391086	Seal — Oil	1
5	212914	Head — Cylinder	1
7	*271075	Gasket — Cylinder Head	1
8	391406	Breather Assembly	1
9	*27803	Gasket — Valve Cover	1
10	93394	Screw	1
11	280100	Tube — Breather	1
12	*270808	Gasket — Crankcase Cover — 1/64" thick	1
	*270915	Gasket — Crankcase Cover — .005" thick	1
	*270916	Gasket — Crankcase Cover — .009" thick	1
13	93723	Screw — Cylinder Head (3" long)	1
15	91084	Plug — Oil Drain	1
16	399696	Crankshaft Note: To Replace Crankshaft Gear Key, Order Part No. 94196	1
18	391784	Base — Engine	1
20	291675	Seal — Oil	1
22	93585	Screw — Base Mounting	1
24	222698	Key — Flywheel	1
25	394661	Piston Assy. — Standard	1
	394662	Piston Assembly — .010" O.S.	1
	394663	Piston Assembly — .020" O.S.	1
	394664	Piston Assembly — .030" O.S.	1
		Piston Ring Sets: Note: For Chrome Ring Set — Standard Size — Order No. 392331 .	
26	394665	Ring Set — Piston — Std.	1
	391781	Ring Set — Piston — .010" O.S.	1
	391782	Ring Set — Piston — .020" O.S.	1
	391783	Ring Set — Piston — .030" O.S.	1
27	260924	Lock — Piston Pin	1
28	299691	Pin Assembly — Piston — Standard	1
	391286	Pin Assembly — Piston — .005" O.S.	1
29	391775	Rod Assembly — Connecting Note: For Connecting Rod with .020" undersize Crankpin Bore — Order No. 393712 .	1
31	222299	Lock — Connecting Rod Screw	1
32	92909	Screw — Connecting Rod	1
33	261185	Valve — Exhaust	1
34	261462	Valve — Intake	1
35	65906	Spring — Intake Valve	1
36	26828	Spring — Exhaust Valve	1
40	221596	Retainer — Intake Valve	1
41	292260	Rotocoil — Exhaust Valve	1
42	93630	Retainer — Exhaust Valve Rotocoil	2

Ref. No.	Part No.	Description	No. Used
45	261183	Tappet — Valve	1
46	212897	Gear — Cam	1
201	261609	Link — Governor	1
209	261306	Spring — Governor	1
219	391764	Oil Slinger — Governor Gear and Bracket Assembly	1
222	390784	Plate — Governor Control	1
225	231058	Crank — Governor (1/4" dia.)	1
227	391733	Lever Assy. — Governor (For 1/4" dia. Crank)	1
230	222450	Washer — Governor Crank (1/4" I.D.)	1
232	260584	Spring — Governor Link	1
258	93572	Screw — Control Bracket Mounting (3/8" long)	1
265	221535	Clamp — Casing	1
284	93804	Screw — Clamp Mtg.	1
306	222744	Shield — Cylinder	1
307	93163	Screw — Cylinder Shield Mtg.	1
308	222725	Cover — Cylinder Head	1
333	398811	Armature — Magneto	1
334	93381	Screw — Armature Mounting	1
337	293918	Plug — Spark (1-1/2" high — 37-42 M.M.) (Resistor Type)	1
353	92791	Washer — Lock — Shakeproof	1
354	90576	Nut — Hex.	1
356	398808	Wire — Ground	1
358	393411	Gasket Set	1
363	19203	Puller — Flywheel	1
383	89838	Wrench — Spark Plug	1
422	222502	Clamp — Oil Filler Tube	1
523	391841	Cap and Dipstick — Oil Filler	1
524	68838	Seal — Filler Tube	1
525	280134	Tube — Oil Filler	1
527	221428	Clamp	2
552	231055	Bushing — Governor Crank (1/4" I.D.)	1
562	92613	Bolt — Governor Lever	1
592	231082	Nut — Hex.	1
614	93306	Cotter — Hair Pin	1
615	93307	Retainer — E-Ring	1
635	66538	Elbow — Spark Plug	1
657	93496	Screw	1
663	93572	Screw	1
683	93572	Screw	1
741	262199	Gear — Timing	1
757	212359	Link — Counterweight	1
758	391373	Counterweight Assembly	1
759	298909	Pin — Counterweight	1
761	93875	Screw — Counterweight	1
842	270920	Seal — Oil Filler Cap	1
847	392067	Fill Group — Oil	1
851	221798	Terminal — Ignition Cable	1
869	261463	Seat — Intake Valve (Standard)	1
870	210940	Seat — Exhaust Valve (Std.)	1
871	261961	Guide — Exhaust Valve Note: 231218 Guide — Valve (Brass) See Repair Manual	1
985	398525	Insulator Assembly	1

* Included in Gasket Set — Part No. 393411.

ENGINE 11 H.P. BRIGGS & STRATTON MODEL NO. 253707-0195-01 (Continued)

121 CARBURETOR OVERHAUL KIT

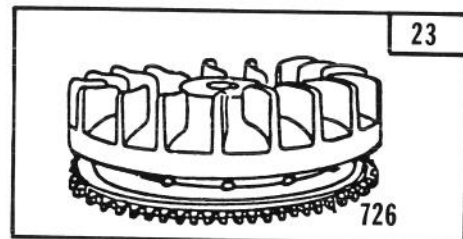
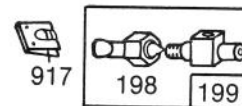
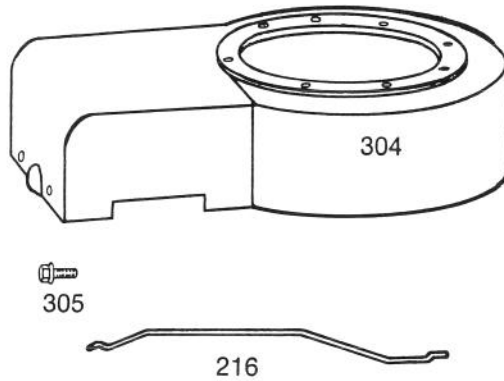
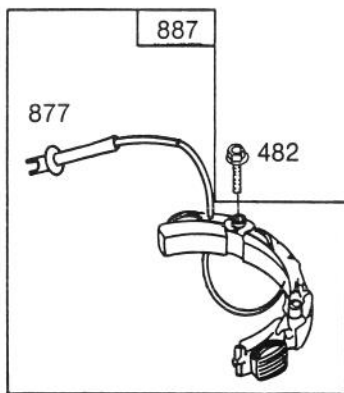
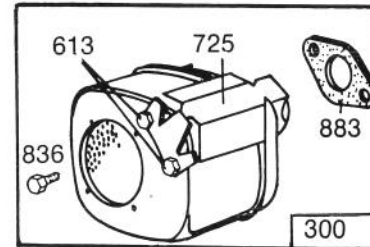
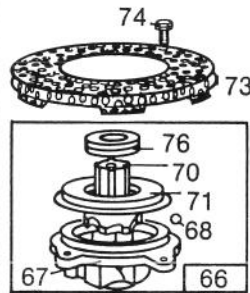
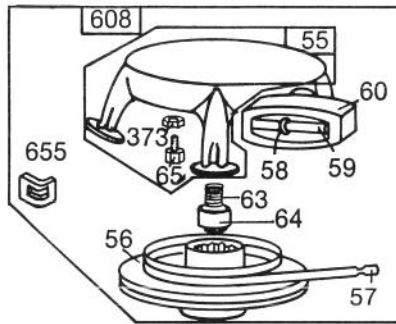
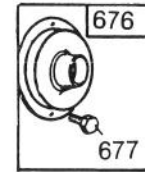
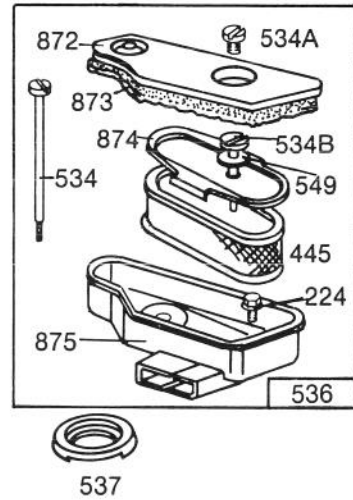
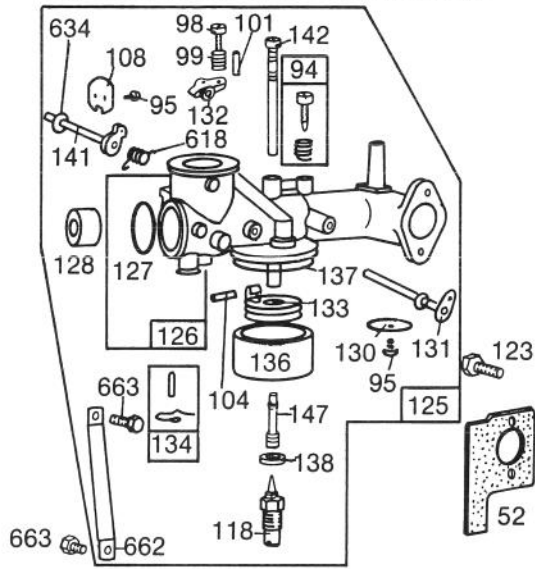

ENGINE 11 H.P. BRIGGS & STRATTON MODEL NO. 253707-0195-01 (Continued)

Ref. No.	Part No.	Description	No. Used
23	391988	Flywheel and Ring Gear Assy. — Magneto	1
52	*270872	Gasket — Carburetor Mounting	1
55	393576	Housing — Rewind Starter (Includes 63" Rope)	1
56	295871	Pulley — Rewind Starter	1
57	294303	Spring — Rewind Starter	1
58	66884	Rope — Rewind Starter (63" long)	1
59	230228	Pin — Starter Grip	1
60	66728	Grip — Starter Rope	1
63	260414	Spring — Ratchet	1
64	230543	Adapter — Ratchet Spring	1
65	93067	Screw — Hex. Head	1
66	394558	Clutch Assy. — Rewind Starter	1
67	394897	Housing — Starter Clutch	1
68	63770	Ball — Clutch	1
70	298799	Ratchet — Rewind Starter Clutch	1
71	221653	Washer — Retainer	1
73	221796	Screen — Rotating	1
74	93042	Screw	1
76	68238	Washer — Ratchet Sealing	1
94	†292681	Valve Assbly. — Carburetor Idle	1
95	93499	Screw — Throttle and Choke Valve Mtg.	1
98	91920	Screw — Machine, Fill. Hd.	1
99	26157	Spring — Throttle Adjustment	1
101	93043	Pin — Throttle Stop	1
104	†230896	Pin — Float Hinge	1
108	222010	Valve Choke	1
118	†396568	Valve — Needle	1
121	394698	Carburetor Overhaul Kit	1
123	93357	Screw — Carburetor Mtg.	1
125	393410	Carburetor Assembly	1
126	391787	Body Assembly — Carburetor (Two 271013 Foam Washers Included in All Ref. 126)	1
127	†221997	Plug — Welch	1
128	211960	Venturi — Carburetor	1
130	222433	Valve — Throttle	1
131	391512	Shaft and Lever — Throttle	1
132	211712	Stop — Throttle	1
133	299707	Float — Carburetor	1
134	†394681	Valve — Fuel Inlet	1
136	221995	Bowl — Float	1

Ref. No.	Part No.	Description	No. Used
137	†270511	Gasket — Float Bowl	1
138	†222014	Washer — Float Bowl	1
141	390684	Shaft and Lever — Choke	1
142	†299740	Nozzle — Carburetor	1
147	†231323	Screw — Nozzle	1
198	293934	Valve — Fuel Shut-Off	1
199	390303	Connector — Fuel Pipe	1
216	261610	Link — Choke	1
224	94018	Screw	1
300	394180	Muffler — Exhaust	1
304	391556	Housing — Blower	1
305	93158	Screw — Blower Housing Mounting	1
373	92987	Nut — Hex.	1
445	393725	Cartridge — Air Cleaner	1
482	93621	Screw	1
534	93911	Screw — Air Cleaner	1
534A	93913	Screw — Air Cleaner	1
534B	93910	Screw — Air Cleaner	1
536	393749	Cleaner — Air	1
537	270853	Gasket — Air Cleaner	1
549	270978	Washer — Air Cleaner	1
608	390391	Starter Assy. — Rewind	1
613	93927	Screw — Hex. Hd.	1
618	261116	Spring — Choke Return	1
634	270382	Washer — Choke Shaft	1
655	222598	Anchor — Spring	1
662	222311	Bracket — Carburetor	1
663	93572	Screw	1
676	396903	Deflector — Muffler	1
677	93705	Screw — Muffler Deflector	1
725	223023	Shield — Muffler	1
726	392134	Gear — Ring (Includes mounting parts)	1
836	93559	Screw — Hex. Head	1
872	396966	Cover Group — Air Cleaner (Includes Gasket)	1
873	397971	Gasket — Air Cleaner Cover	1
874	222898	Plate — Air Cleaner Cartridge	1
875	397321	Body — Air Cleaner	1
877	393814	Diode and Connector Assy. (D.C.)	1
883	270917	Gasket — Exhaust Pipe	1
887	391529	Stator Assembly — Alternator (D.C.)	1
917	223271	Valve Handle — Fuel Shut-Off	1

* Included in Gasket Set — Part No. 393411.

† Included in Carburetor Overhaul Kit — Part No. 394698.

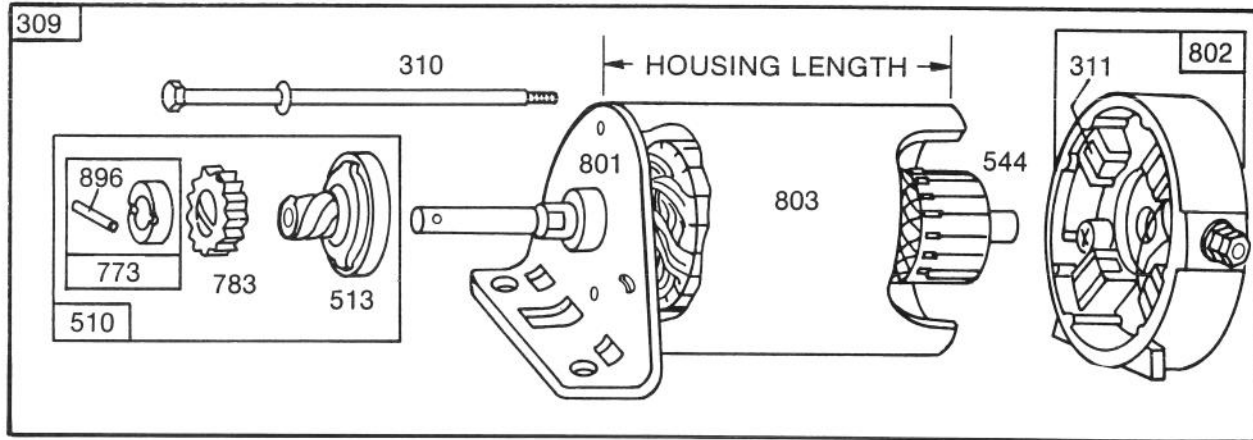

BRIGGS & STRATTON STARTER MOTOR ASSEMBLY (For 8 H.P. & 11 H.P. Engines)

Ref. No.	Part No.	Description	No. Used
309	394805	Motor and Drive Assembly	1
310	94003	Thru Bolt Assembly	1
311	395538	Brush Assembly	1
510	391461	Drive Assembly	1
513	391135	Clutch Assembly	1
544	392747	Armature Assembly	1

Ref. No.	Part No.	Description	No. Used
773	391462	Retainer and Pin	1
783	280104	Gear	1
801	394856	End Cap Assembly Drive	1
802	395537	End Cap Assy. Commutator	1
803	393825	Housing Assembly	1
896	93754	Roll Pin	1

PRODUCT CHANGES

In an effort to make improvements available to TORO owners as quickly as possible, minor changes are incorporated into Toro's products from time to time that do not become immediately shown in the Parts Catalog. If such a change apparently has been made in your unit, which is not reflected in your manual, see your TORO Distributor or his Authorized TORO Service Dealer for information and part numbers.

IDENTIFICATION AND ORDERING

MODEL AND SERIAL NUMBERS

The Rider has two identification numbers: a model number and a serial number. The two numbers are stamped on a decal which is located on the left side of frame in front of rear wheel. In any correspondence concerning the rider, supply model and serial numbers to assure that correct information and replacement parts are obtained.

To order replacement parts from an Authorized TORO Service Dealer, supply the following information:

1. Model and serial numbers of the rider.
2. Part number, description, and quantity of part(s) desired.

Note: Do not order by reference number if a parts catalog is being used; use the PART NUMBER.

The Toro Promise

A Two Year Limited Warranty

On All

Gasoline Powered Consumer Products

The Toro Company promises to repair your TORO Product if defective in materials or workmanship. The following time periods from the date of purchase apply:

Residential Product 2 Years

Residential Products Used Commercially 90 Days

The costs of parts and labor are included, but the customer pays the transportation costs. Just return any residential product to an Authorized TORO Service Dealer or TORO Distributor.

Should you feel your TORO Product is defective and wish to rely on The Toro Promise, the following procedure is recommended:

1. Contact any Authorized TORO Service Dealer, TORO Master Service Dealer, or TORO Distributor (the Yellow Pages of your telephone directory is a good reference source).
2. He will either instruct you to return the product to him or recommend another Authorized TORO Service outlet which might be more convenient.
3. Bring the product along with your original sales slip, or other evidence of purchase date, to the service dealer.
4. The servicing dealer will inspect the unit, advise you whether the product is defective and, if so, make all repairs necessary to correct the defect without extra charge to you.

If for any reason you are dissatisfied with the dealer's analysis of the defect or the service performed, you may contact us.

Write:

TORO Consumer Service Department
8111 Lyndale Avenue South
Minneapolis, Minnesota 55420

The above remedy of product defects through repair by an Authorized TORO Service Dealer is the purchaser's sole remedy for any defect.

THERE IS NO OTHER EXPRESS WARRANTY. ALL IMPLIED WARRANTIES OF MERCHANTABILITY AND

FITNESS FOR USE ARE LIMITED TO THE DURATION OF THE EXPRESS WARRANTY.

Some states do not allow limitations on how long an implied warranty lasts, so the above limitation may not apply to you.

This warranty applies only to parts or components which are defective and does not cover repairs necessary due to normal wear, misuse, accidents, or lack of proper maintenance. Regular, routine maintenance of the unit to keep it in proper operating condition is the responsibility of the owner.

All warranty repairs reimbursable under The Toro Promise must be performed by an Authorized TORO Service Dealer using Toro approved replacement parts.

Repairs or attempted repairs by anyone other than an Authorized TORO Service Account are not reimbursable under The Toro Promise. In addition, these unauthorized repair attempts may result in additional malfunctions, the correction of which is not covered by warranty.

THE TORO COMPANY IS NOT LIABLE FOR INDIRECT, INCIDENTAL OR CONSEQUENTIAL DAMAGES IN CONNECTION WITH THE USE OF THE PRODUCT INCLUDING ANY COST OR EXPENSE OF PROVIDING SUBSTITUTE EQUIPMENT OR SERVICE DURING PERIODS OF MALFUNCTION OR NON-USE.

Some states do not allow the exclusion or limitation of incidental or consequential damages, so the above limitation or exclusion may not apply to you.

This warranty gives you specific legal rights, and you may also have other rights which vary from state to state.

COUNTRIES OTHER THAN THE UNITED STATES OR CANADA

Customers who have purchased TORO products exported from the United States or Canada should contact their TORO Distributor (Dealer) to obtain guarantee policies for your country, province or state. If for any reason

you are dissatisfied with your Distributor's service or have difficulty obtaining guarantee information, contact the TORO importer. If all other remedies fail, you may contact us at The Toro Company.

MAINTENANCE RECORD
