

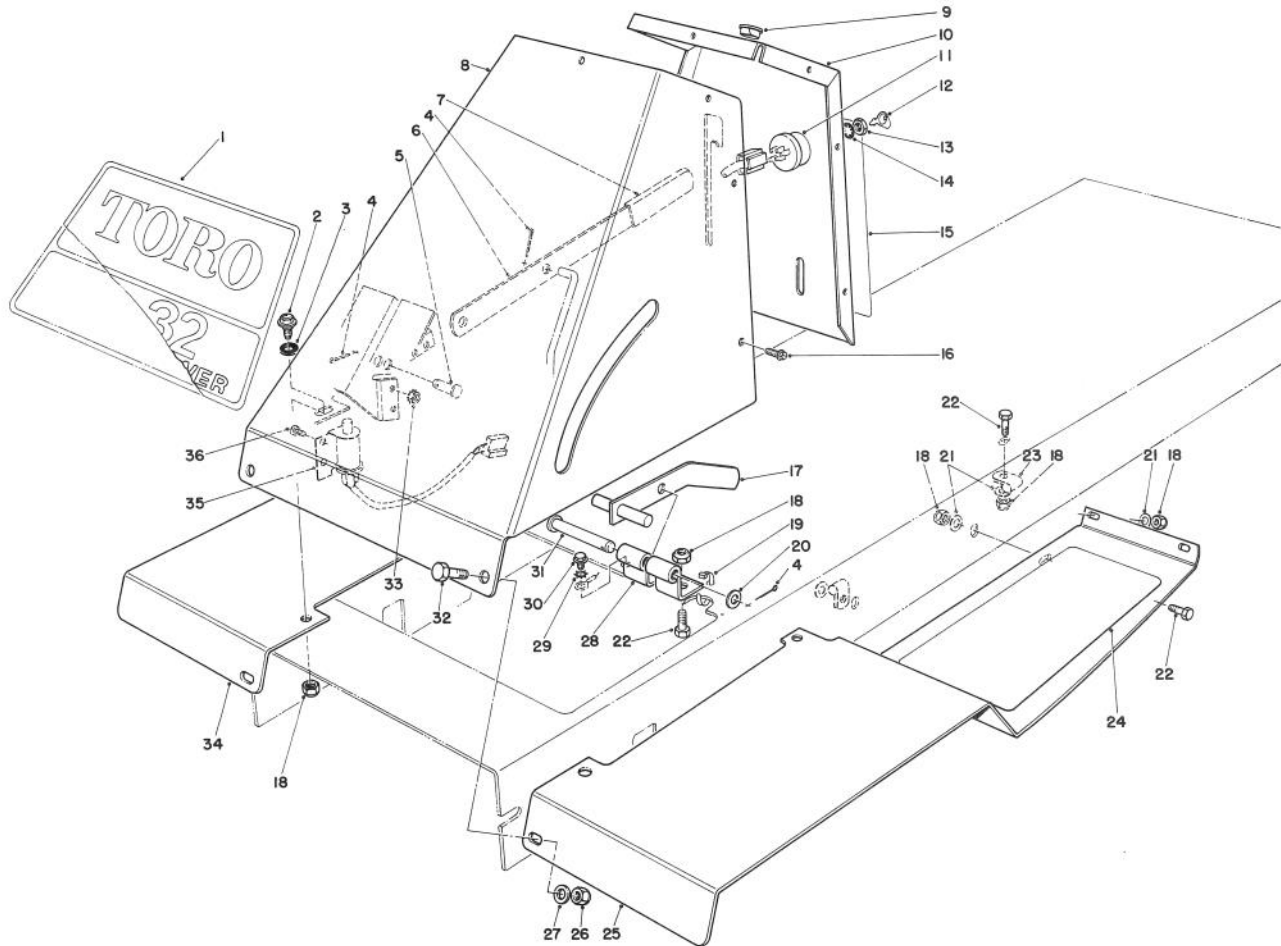

MODEL NO. 56145-5000001 & UP

PARTS CATALOG

8 H.P. REAR ENGINE RIDER - ELECTRIC



FRONT TOWER ASSEMBLY

Ref. No.	Part No.	Description	No. Used
1	47-1550	Decal — Toro 832	1
2	5-2490	Bolt — Shoulder	4
3	3-3287	Spacer — Rubber	4
4	3272-6	Cotter Pin	2
5	283-2	Pin Clevis	1
6	47-1060	Lever — Engagement	1
7	47-1970	Grip — Engagement	1
8	47-1520	Tower — Front	1
9	256-275	Nyliner	1
10	47-1210	Tower — Rear	1
11	23-0660	Switch — Ignition	1
12	218-412	Key — Ignition	1
13	218-461	Nut — Hex	1
14	3254-5	Washer — Lock Internal Tooth	1
15	47-0200	Decal — Ignition/Engagement	1
16	32104-76	Screw — Self Tapping Acorn Hd.	7
17	47-1290	Parking Brake	1
18	3296-29	Nut — Lock	15

Ref. No.	Part No.	Description	No. Used
19	3290-378	Cable Tie	1
20	3256-24	Washer — Flat	1
21	3256-23	Washer — Flat Plain	9
22	322-3	Capscrew	7
23	2412-68	Cable Clamp	2
24	47-1440	Tread — Foot	2
25	47-0940	Footrest — L.H.	1
26	32152-4	Nut — Lock	2
27	3256-22	Washer — Plain	2
28	47-2060	Bracket — Parking Brake	1
29	3254-2	Washer — Lock External	1
30	32104-82	Screw — Self Tapping	1
31	283-52	Clevis Pin	1
32	321-3	Capscrew	2
33	32149-7	Nut — Hex	2
34	47-0930	Footrest — R.H.	1
35	28-4450	Switch — Interlock	1
36	3252-2	Screw — Machine Round Hd.	2

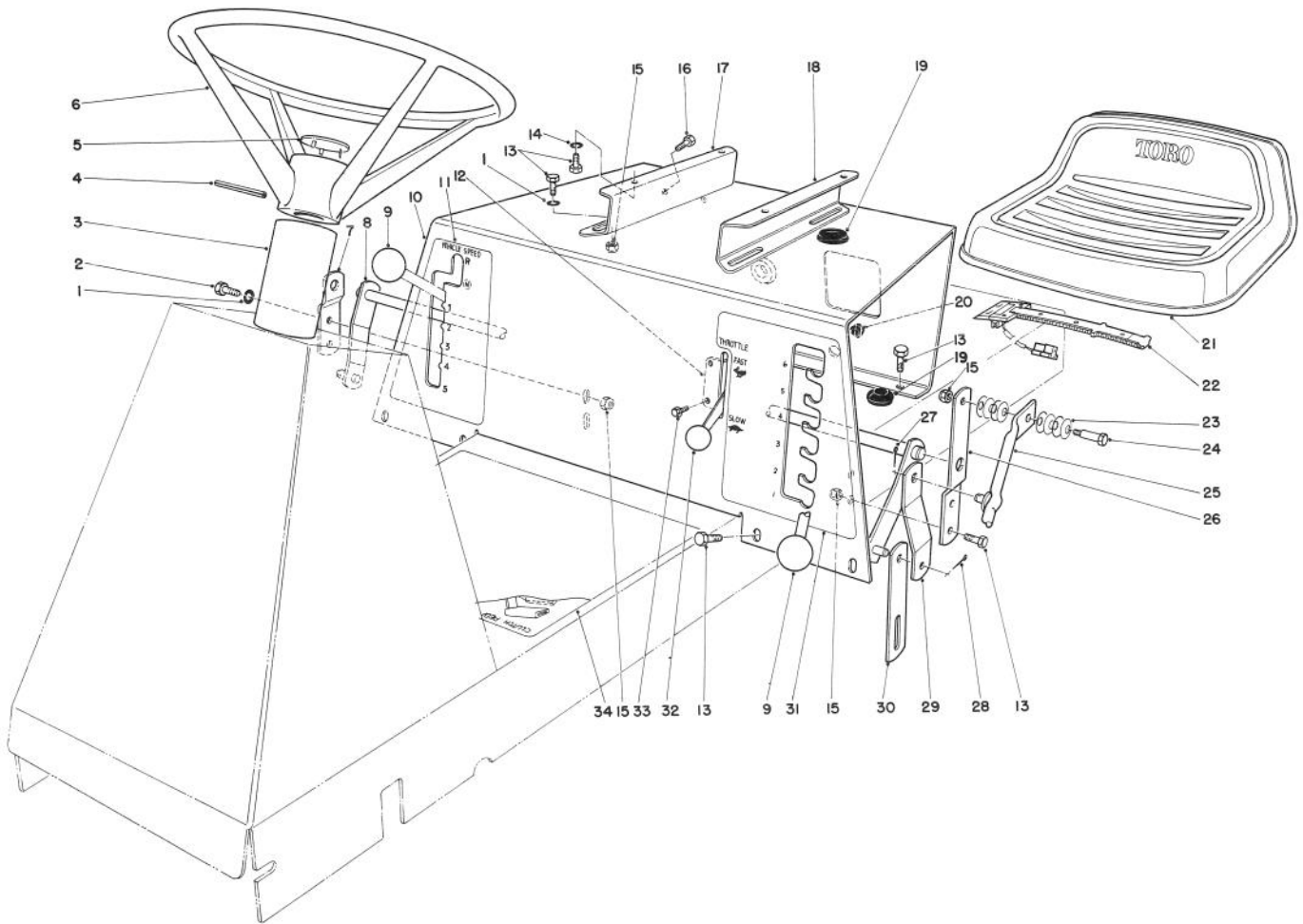

SEAT & STEERING WHEEL ASSEMBLY

Ref. No.	Part No.	Description	No. Used
1	3256-23	Washer	6
2	322-5	Capscrew	2
3	47-1980	Cover — Steering Shaft	1
4	32121-78	Pin — Roll	1
5	47-2070	Insert — Steering Wheel	1
6	49-3240	Wheel — Steering (Incl. Ref. #5)	1
7	47-0810	Bracket H.O.C. Support	1
8	47-0860	Lever — Arm Height Of Cut	1
9	233-4	Knob	2
10	47-0530	Support Seat	1
11	47-0230	Decal — Transmission	1
12	47-0250	Throttle Control (Incl. Ref. #32)	1
13	322-3	Capscrew	20
14	3253-4	Washer — Lock	4
15	3296-29	Nut — Lock	9
16	321-3	Capscrew	2
17	47-0510	Bracket — Seat R.H.	1

Ref. No.	Part No.	Description	No. Used
18	47-0520	Bracket — Seat L.H.	1
19	237-100	Grommet	3
20	237-136	Grommet	1
21	38-0850	Seat	1
22	38-1420	Switch Seat	1
23	3290-413	Washer — Belleville	8
24	28-0540	Bolt — Shoulder	1
25	47-1850	Lever — Height Of Cut	1
26	47-1840	Bracket — Height Of Cut	1
27	3272-6	Pin — Cotter	1
28	3272-10	Cotter Pin	2
29	47-0850	Bracket — Height Of Cut Engagement	1
30	47-0820	Link — Deck Suspension	2
31	49-2760	Decal — Height Of Cut	1
32	233-25	Knob	1
33	32104-76	Screw — Self Tapping Acorn Hd.	2
34	54-9240	Decal — Instructions	1

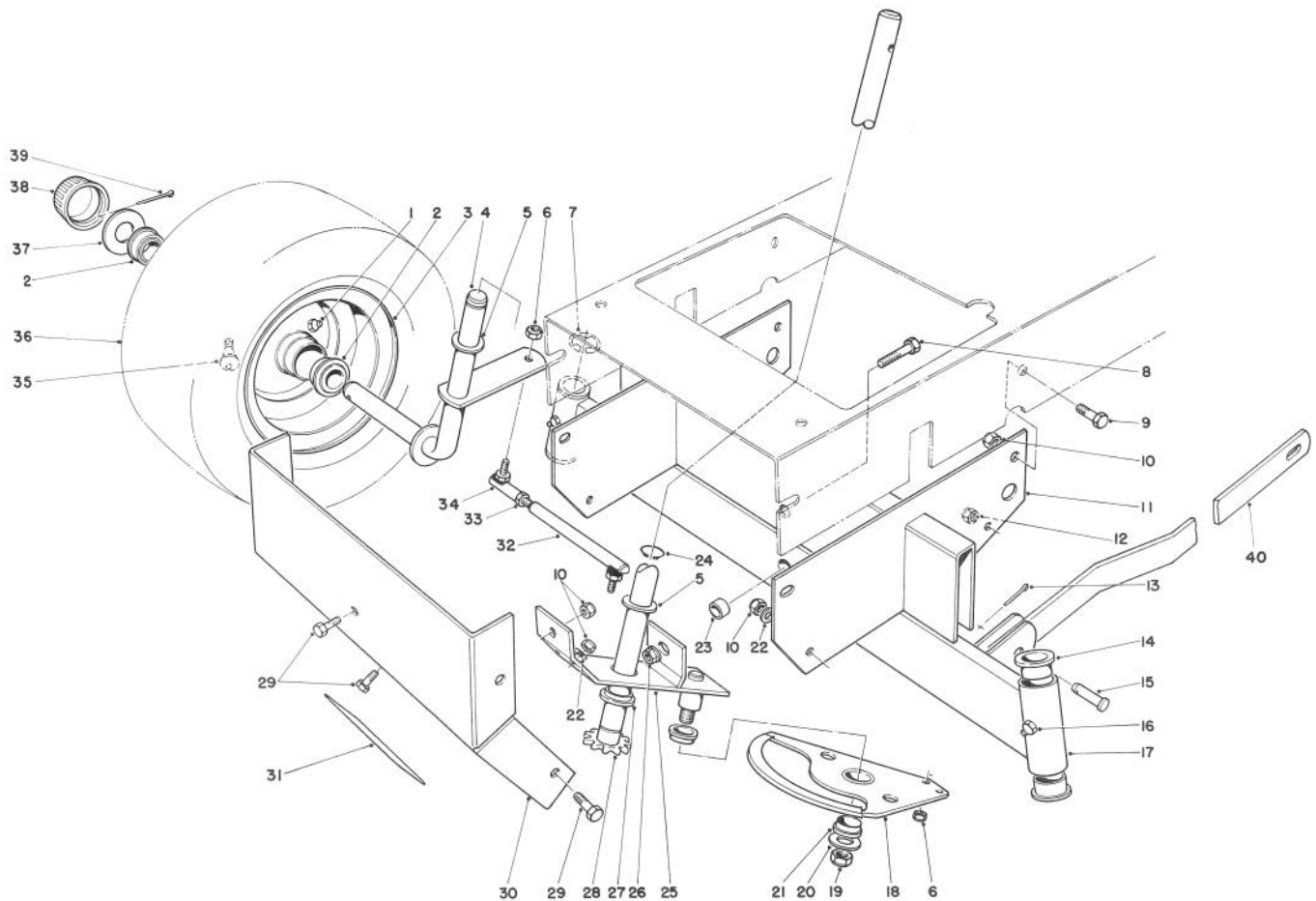

FRONT AXLE ASSEMBLY

Ref. No.	Part No.	Description	No. Used
1	302-5	Grease Fitting	2
2	251-210	Bearing	4
3	217-80	Rim	2
4	47-0600	Spindle — R.H.	1
*	47-0590	Spindle — L.H.	1
5	3-6498	Washer — Thrust	3
6	3296-4	Nut — Lock	4
7	32151-48	Ring — Retaining External	2
8	325-6	Capscrew	1
9	322-2	Capscrew	2
10	3296-29	Nut — Lock	9
11	47-0760	Axle Support	1
12	32152-4	Nut — Lock	1
13	3272-6	Pin — Cotter	2
14	27-9080	Flange Bearing	4
15	283-2	Pin — Clevis	2
16	302-49	Grease Fitting	2
17	47-0980	Axle — Front (Incl. Ref. #14 & 16)	1
18	47-0690	Rack — Steering	1
19	32152-3	Nut — Lock	1
20	29-8910	Washer	1
21	47-0700	Bushing — Flange	2

Ref. No.	Part No.	Description	No. Used
22	3256-23	Washer — Plain	6
23	28-0380	Spacer — Front Axle	1
24	32120-93	Ring — Retaining External	1
25	47-0620	Rack — Bracket Steering (Incl. Ref. #27)	1
26	32128-23	Nut — Lock	1
27	47-0700	Bearing — Flange	1
28	47-0650	Shaft — Steering	1
29	322-4	Screw — Cap Hex Hd.	7
30	47-1000	Cover — Front	1
31	26-4830	Decal — Warning	1
32	47-0610	Tie Rod — Steering (Incl. Ref. #32 & 33)	2
33	3220-2	Jam Nut	2
34	2411-32	Ball Joint	2
35	232-27	Valve Stem w/Cap	2
36	231-108	Tire	2
37	28-2480	Washer	2
38	28-0060	Hub Cap	2
39	3272-12	Pin — Cotter	2
40	47-0010	Arm — Front Deck Suspension	2
†	232-44	Inner Tube	2

†Service Replacement Part

*Not Illustrated

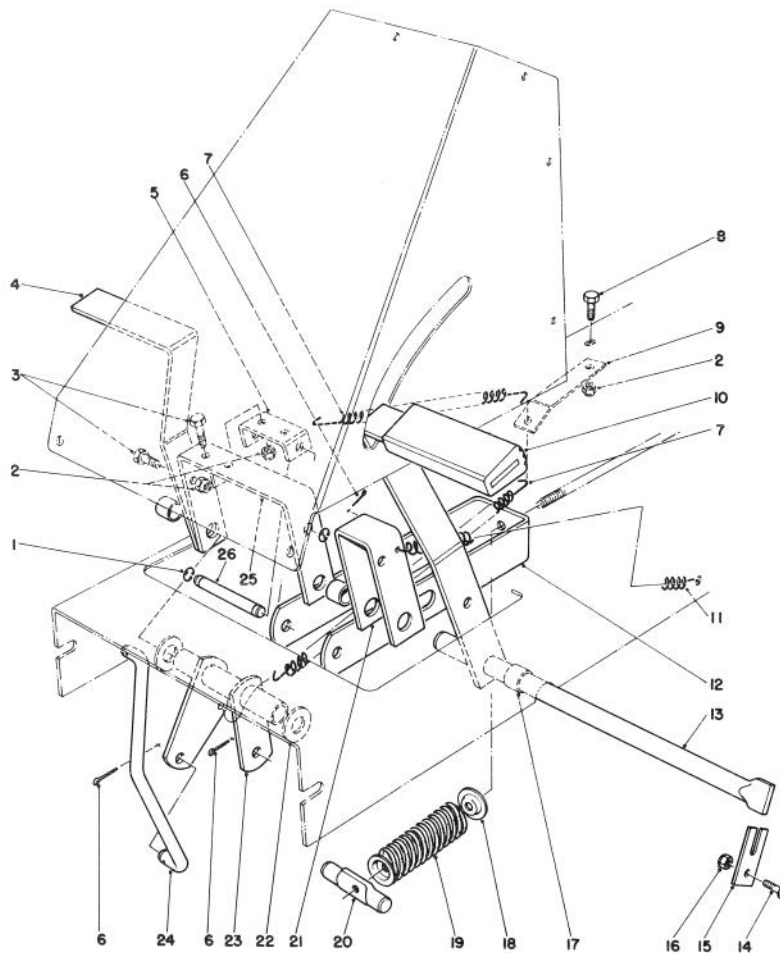

BRAKE & CLUTCH ASSEMBLY

Ref. No.	Part No.	Description	No. Used
1	32120-18	Ring — Retaining External	2
2	3296-29	Nut — Lock	5
3	322-5	Capscrew	4
4	47-0540	Pedal	2
5	47-1380	Bracket — Brake	1
6	3272-6	Cotter Pin	4
7	27-8960	Spring — Extension	2
8	322-3	Screw — Cap Hex Hd.	1
9	47-1310	Bracket — Spring Retaining	1
10	47-1570	Pad — Foot Pedal	2
11	12-8810	Spring — Tension	1
12	47-1180	Bracket — Engagement	1
13	47-0770	Shaft — Pedal Pivot	1

Ref. No.	Part No.	Description	No. Used
14	321-3	Capscrew	1
15	47-0780	Retainer — Shaft	1
16	32152-4	Nut — Lock	1
17	47-0570	Spacer — Pedal	3
18	47-1140	Retainer — Spring Top	2
19	47-0960	Spring — Compression	1
20	47-1200	Shaft — Adjusting	1
21	47-0560	Bracket — Clutch Pedal	1
22	3256-27	Washer — Plain	2
23	47-1040	Tube — Pivot	1
24	47-1050	Arm — Engagement	1
25	47-0550	Bracket — Brake Pedal	1
26	47-1230	Pin — Clevis	1

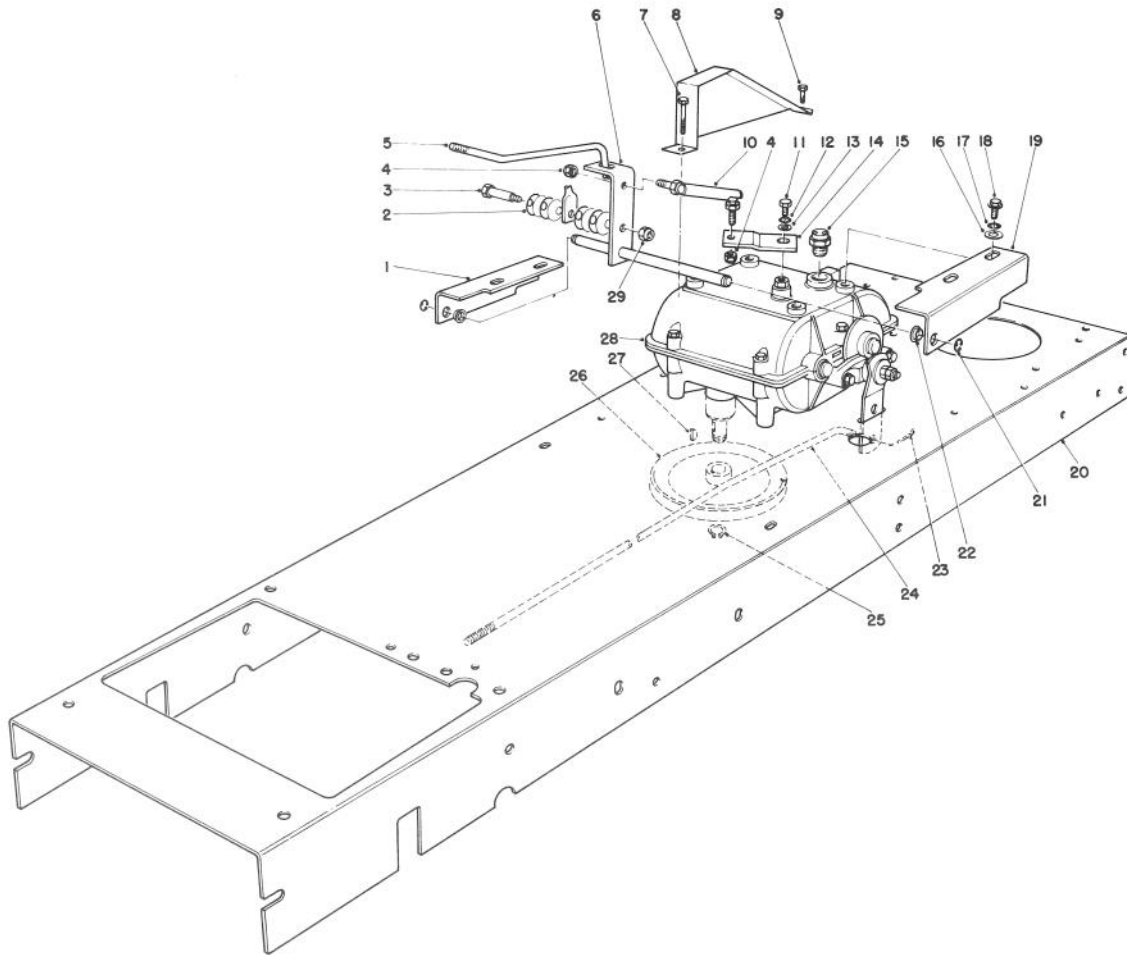

TRANSMISSION LINKAGE ASSEMBLY

Ref. No.	Part No.	Description	No. Used
1	47-0390	Bracket — Shift R.H.	1
2	3290-413	Washer — Belleville	8
3	28-0540	Bolt — Shoulder	1
4	3296-13	Nut — Lock	2
5	47-0440	Lever — Shift	1
6	47-0430	Lever — Shifting	1
7	322-11	Screw — Cap Hex Hd.	1
8	47-1220	Guard — Chain	1
9	322-3	Capscrew	1
10	47-0450	Linkage — Tie Rod Shift	1
11	329-4	Capscrew	1
12	3253-3	Lockwasher	1
13	3256-22	Washer — Plain	1
14	47-0460	Link Shift Lever	1
15	28-4250	Switch — Neutral Start	1

Ref. No.	Part No.	Description	No. Used
16	3256-23	Washer — Plain	4
17	3253-4	Washer — Lock	4
18	32144-11	Screw — Thread Forming	4
19	47-0400	Bracket — Shift L.H.	1
20	47-0970	Frame — Main	1
21	32151-70	Ring — Retaining External	2
22	256-195	Nyliner	2
23	3272-6	Pin — Cotter	1
24	47-1250	Rod — Brake	1
25	32120-64	Retainer — Ring External	1
26	7-4085	Pulley — Transmission	1
27	3257-5	Key — Woodruff	1
28	47-1530	Transmission	1
29	3296-29	Nut — Lock	1

TRANSMISSION MODEL 770

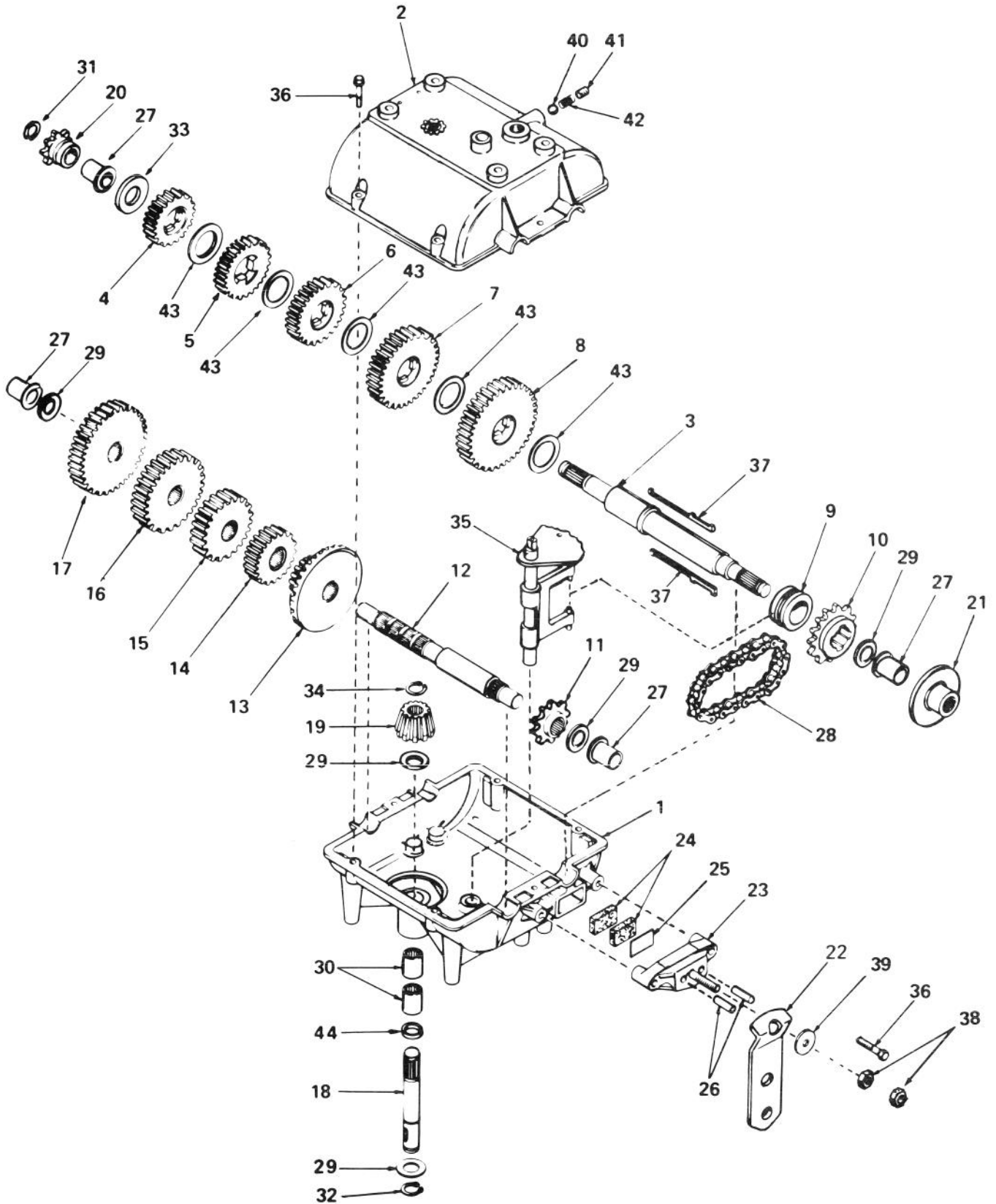

TRANSMISSION MODEL 770

Ref. No.	Part No.	Description	No. Used
1	770061	Case — Transmission	1
2	772083	Cover — Transmission	1
3	776161	Shaft — Output & Brake	1
4	778121A	Gear — Spur (20 teeth)	1
5	778122A	Gear — Spur (22 teeth)	1
6	778123A	Gear — Spur (25 teeth)	1
7	778124A	Gear — Spur (30 teeth)	1
8	778125	Gear — Spur (35 teeth)	1
9	784266	Collar, Shift	1
10	786083	Sprocket (18 teeth)	1
11	786082	Sprocket (9 teeth)	1
12	776134	Shaft — Counter	1
13	778109	Gear — Bevel (42 tooth & 15 tooth spur gear)	1
14	778126A	Gear — Spur (20 teeth)	1
15	778127A	Gear — Spur (25 teeth)	1
16	778128A	Gear — Spur (28 teeth)	1
17	778129A	Gear — Spur (30 teeth)	1
18	776135	Shaft — Input	1
19	778113A	Bevel Pinion — Input	1
20	786048	Sprocket (8 teeth)	1
21	790003	Disk — Brake	1
22	790013	Lever, Brake	1

Ref. No.	Part No.	Description	No. Used
23	790005	Holder — Brake Pad	1
24	790006	Pad, Brake	1
25	790007	Plate — Brake Pad	1
26	786026	Pin — Dowel	1
27	780105A	Bushing — Flanged	1
28	786081	Chain Roller (No. 41 chain, 24 links)	1
29	780072	Race, Thrust	1
30	780086	Bearing, Needle	1
31	792072	Ring, Retaining	1
32	792035	Ring, Retaining	1
33	780109	Washer	1
34	788040	Ring, Retaining	1
35	784267	Rod & Fork Assy., Shift	1
36	792073	Screw, Hex Hd.	1
37	792089A	Key	1
38	792075	Nut, Lock	1
39	792076	Washer — Flat	1
40	792077	Ball — Steel	1
41	792078	Screw — Set	1
42	792079	Spring	1
43	780108	Washer — Thrust	1
44	792001	Ring, Square Cut	1

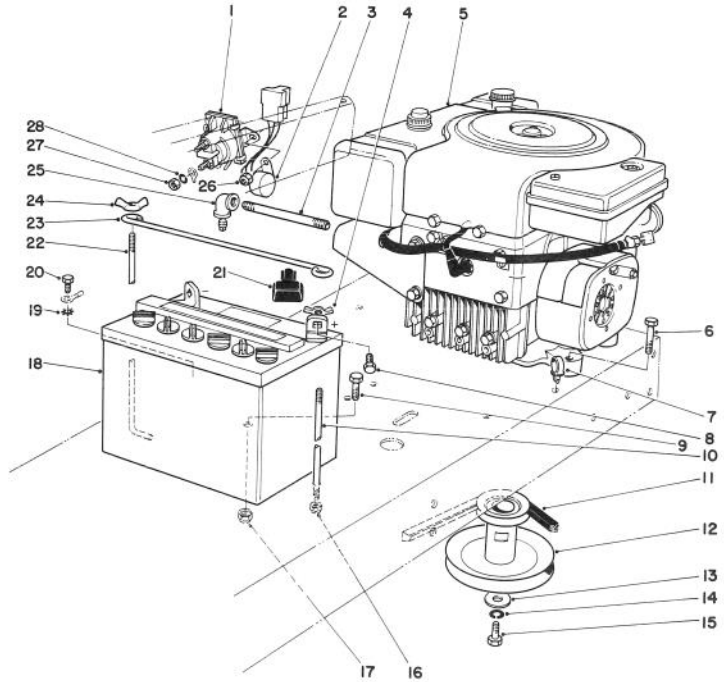
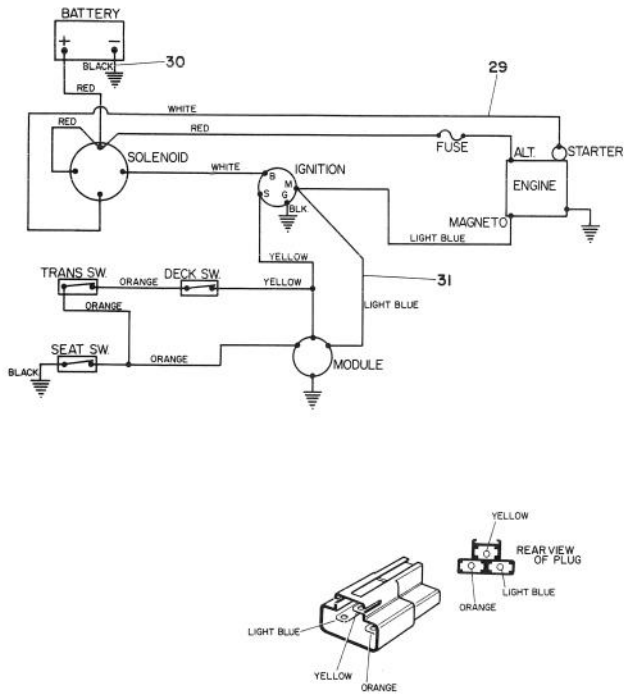

ENGINE ASSEMBLY

Ref. No.	Part No.	Description	No. Used
1	47-1910	Solenoid	1
2	28-7890	Module — Interlock	1
3	289-19	Pipe — Nipple	1
4	32103-22	Nut — Wing	2
5	47-1650	Engine	1
6	322-7	Screw — Cap Hex Hd.	4
7	51-2830	Clip — Cable	1
8	321-3	Capscrew	2
9	323-2	Capscrew	1
10	10-8120	Bolt — Battery	1
11	47-1410	Belt — Traction Drive	1
12	47-1960	Pulley — Engine	1
13	27-8920	Washer	1
14	3253-22	Washer — Lock	1
15	3212-5	Screw — Cap Hex Hd.	1
16	32149-2	Nut — Lock	1

Ref. No.	Part No.	Description	No. Used
17	32152-2	Nut — Lock	1
18	51-2820	Battery	1
19	3254-2	Washer — Lock External Tooth	1
20	32104-82	Screw — Self Tapping Hex Washer Hd.	1
21	28-8080	Boot Terminal	1
22	12-5950	Support Battery	1
23	47-1680	Hold Down — Battery	1
24	32103-12	Nut — Wing	2
25	2811-16	Elbow — 90° Female	1
26	32152-4	Nut — Lock	2
27	3218-1	Nut — Hex Jam	2
28	3253-3	Washer — Lock	2
29	47-0240	Wiring Harness	1
30	47-0260	Wire — Battery to Ground	1
31	47-1560	Wiring Harness	1

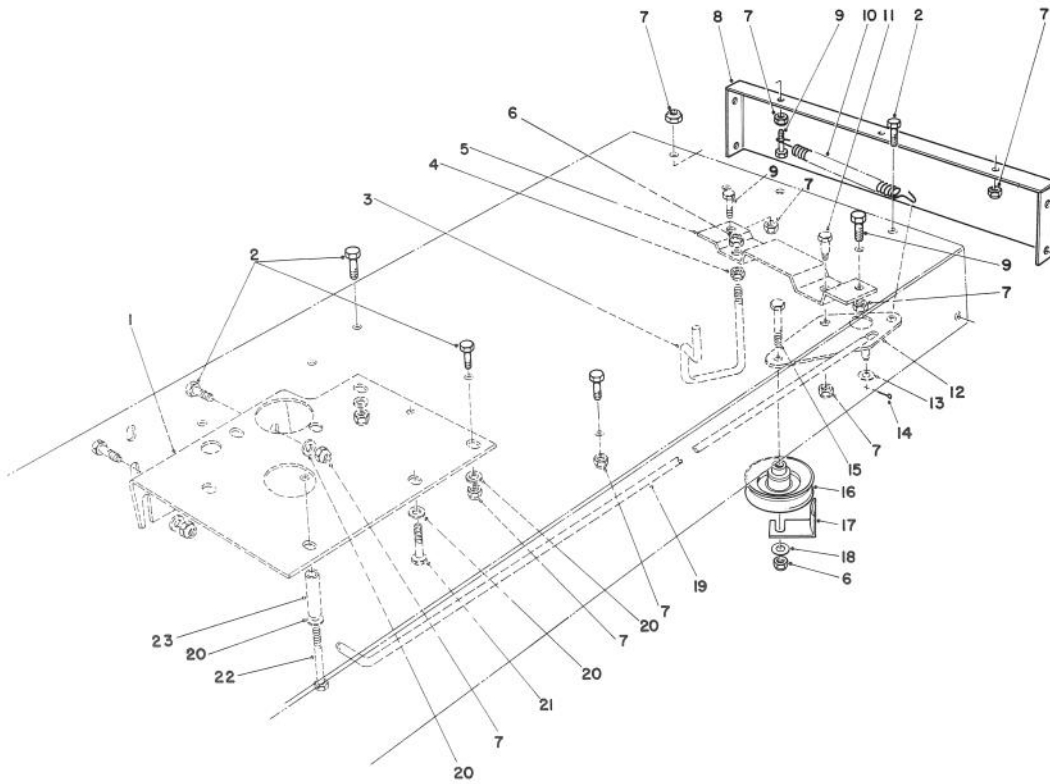

TRACTION ASSEMBLY

Ref. No.	Part No.	Description	No. Used
1	47-1950	Plate — Reinforcement	1
2	322-3	Capscrew	5
3	47-0500	Guide — Belt	1
4	32153-2	Locknut	1
5	47-0471	Bracket — Traction Support	1
6	32152-2	Nut — Lock	2
7	3296-29	Nut — Lock	12
8	47-0730	Frame — Rear	1
9	322-7	Capscrew	2
10	27-8960	Spring — Extension	1
11	37-8770	Screw — Shoulder	1
12	47-0481	Bracket — Traction Pivot	1

Ref. No.	Part No.	Description	No. Used
13	3256-22	Washer — Plain	1
14	3272-6	Pin — Cotter	1
15	323-9	Screw — Cap Hex Hd.	1
16	12-5820	Pulley — Idler	1
17	12-9020	Retainer — Belt	1
18	3256-24	Washer — Plain	1
19	47-0490	Rod — Traction	1
20	3256-23	Washer	7
21	32140-45	Screw — Machine Hex Hd.	3
22	322-11	Screw — Cap Hex Hd.	1
23	47-0920	Spacer — Outer Tube	1

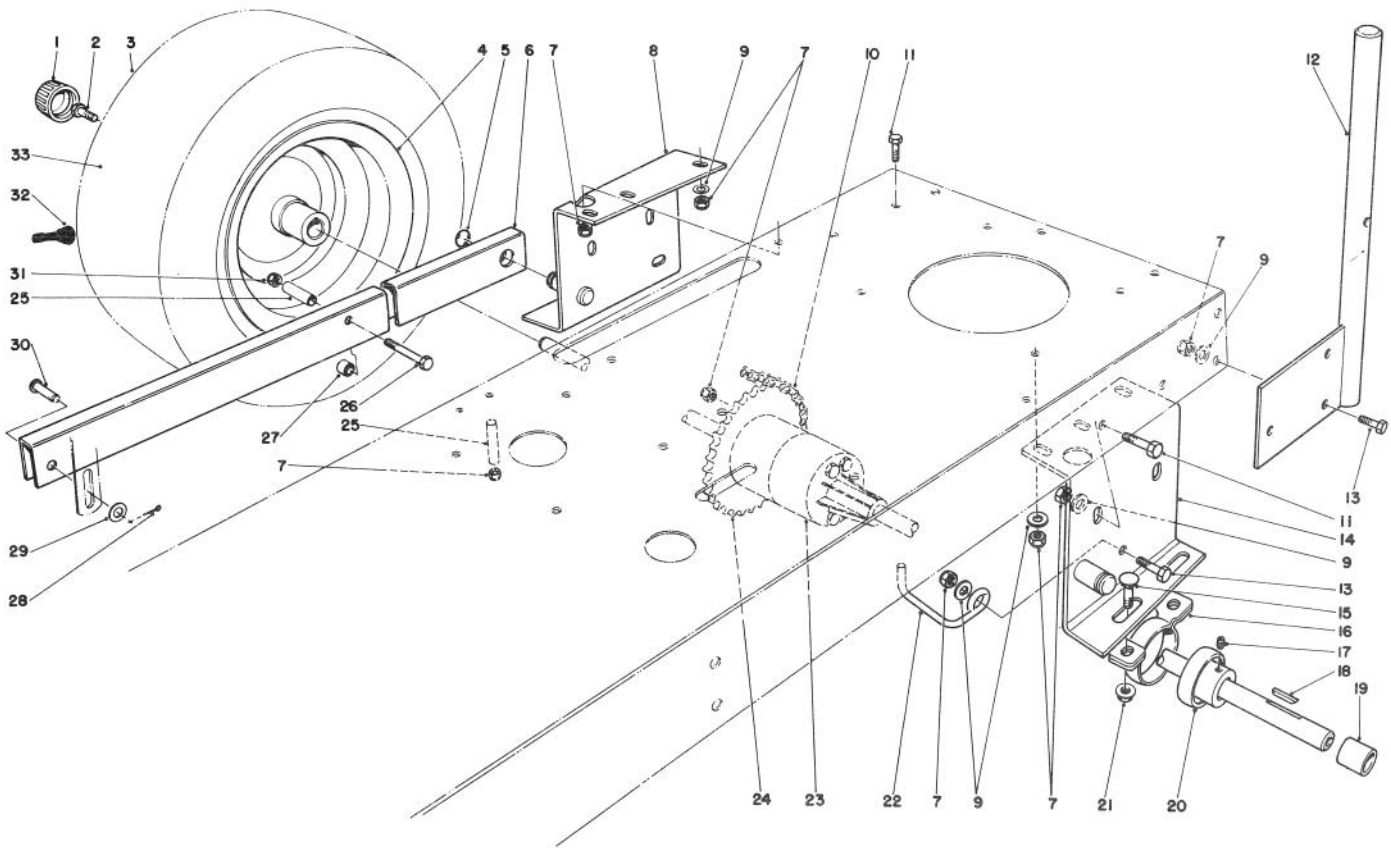

REAR AXLE ASSEMBLY

Ref. No.	Part No.	Description	No. Used
1	28-0060	Hub Cap	2
2	36-4030	Capscrew Hex Hd.	2
3	231-97	Tire	2
4	242-70	Rim	2
5	32151-48	Ring — Retaining External	2
6	47-0020	Arm — Rear Deck Suspension	2
7	3296-29	Nut — Lock	18
8	47-0880	Support — Rear Axle R.H.	1
9	3256-23	Washer — Plain	12
10	47-1510	Chain	1
11	322-4	Screw — Cap Hex Hd.	4
12	47-2050	Stand Bar	2
13	322-5	Capscrew — Hex Hd.	7
14	47-0890	Support — Rear Axle L.H.	1
15	3231-30	Bolt — Carriage	4
16	47-1480	Retainer — Pillow Block	2
17	3245-35	Set Screw 1/4-28	4
17	3246-15	Set Screw 5/16-18	4

Ref. No.	Part No.	Description	No. Used
18	3257-40	Key — Hi Pro	2
19	47-0740	Spacer — Rear Axle	2
20	47-1490	Bearing — Self Aligning (Incl. Ref. #17)	2
21	32128-21	Nut — Lock Flange	4
22	47-2010	Belt Guide — Engine Pulley	1
23	47-1470	Differential	1
24	47-1500	Sprocket Differential	1
25	47-0920	Spacer — Outer Tube	3
26	323-13	Screw — Cap Hex Hd.	2
27	47-0910	Spacer — Inner Tube	2
28	3272-6	Cotter Pin	2
29	3256-24	Washer — Plain	2
30	283-42	Pin — Clevis	2
31	32152-2	Nut — Lock	2
32	232-27	Valve Stem w/Cap	2
33†	232-39	Inner Tube	2

†Service Replacement Part

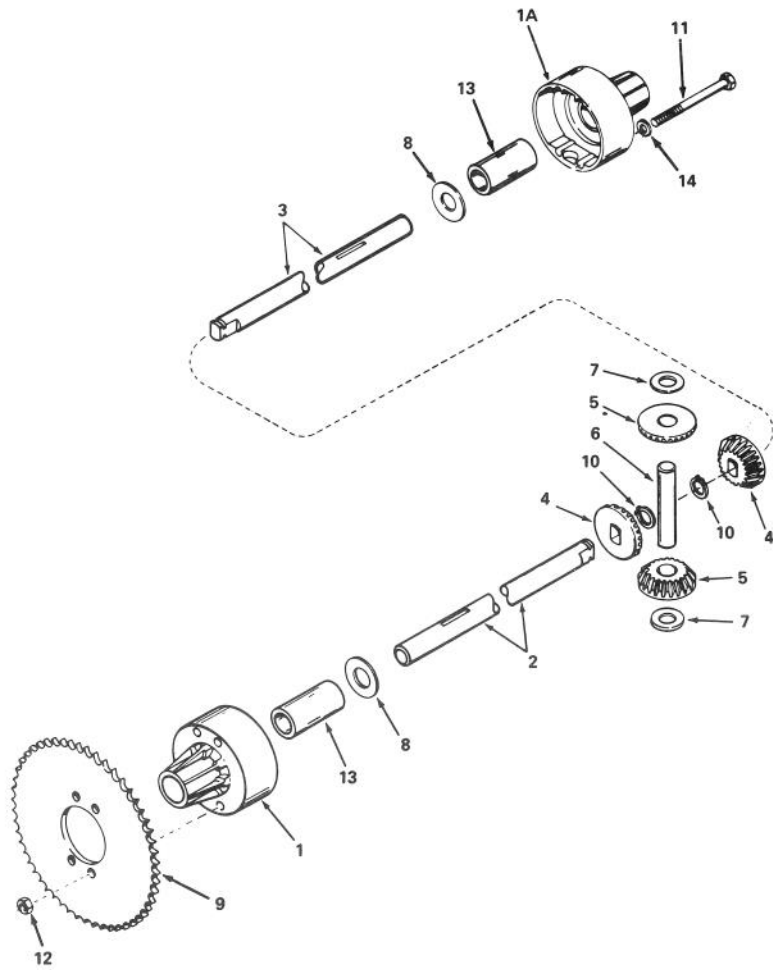

DIFFERENTIAL MODEL 100-024

Ref. No.	Part No.	Description	No. Used
1	774344	Housing — Differential Carrier (Incl. #13)	1
1A	774345	Housing — Differential Carrier (Incl. #13)	1
2	774489	Axle (9-5/8" long)	1
3	774488	Axle (18-1/4" long)	1
4	778067	Gear — Bevel	1
5	778068	Gear — Pinion	1

Ref. No.	Part No.	Description	No. Used
6	786040	Pin — Drive	1
7	780096	Washer — Thrust	1
8	780001	Washer — Sprocket	1
10	792018	Ring — Snap	1
11	792041	Screw — Hex Hd.	1
12	792042	Nut — Lock	1
13	780077	Bushing	1
14	792061	Washer	1

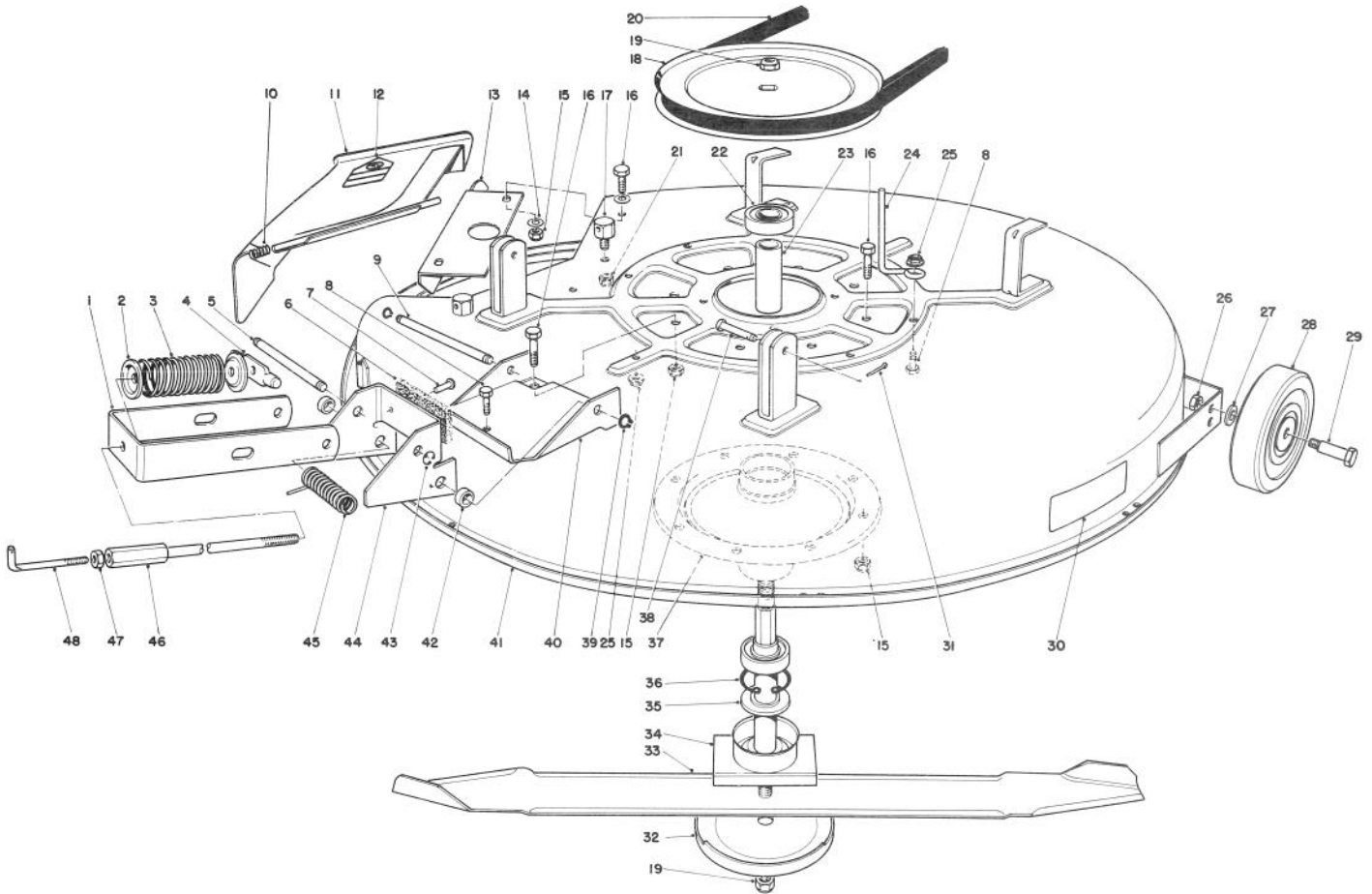

MOWER ASSEMBLY

Ref. No.	Part No.	Description	No. Used
1	47-1180	Bracket — Engagement	1
2	47-1140	Retainer — Spring Top	2
3	47-0960	Spring — Compression	1
4	47-1200	Shaft — Adjusting	1
5	47-1230	Pin — Clevis	1
6	47-0210	Pad — Brake	1
7	3295-43	Rivet	2
8	321-4	Capscrew	3
9	47-1670	Pin — Clevis	1
10	28-8010	Spring — Torsion	1
11	44-5930	Deflector Assembly (Incl. Ref. #12)	1
12	54-9220	Decal — Danger	1
13	44-5720	Baffle Deck	1
14	3256-23	Washer — Plain	4
15	3296-29	Nut — Lock	10
16	322-4	Capscrew	10
17	28-7350	Pivot Post	1
18	47-1350	Pulley	1
19	17-0980	Nut — Special	2
20	47-1420	V-Belt	1
21	32153-2	Nut — Lock	1
22	251-297	Bearing	2
23	47-0100	Spacer — Bearing	1
24	47-0270	Guide — Belt	2

Ref. No.	Part No.	Description	No. Used
25	32128-10	Nut — Locking Flange	3
26	32146-6	Nut — Lock	2
27	3256-24	Washer — Plain	2
28	29-6010	Wheel	2
29	3-2652	Wheel Bolt	2
30	47-7240	Decal — Deck	1
31	3272-6	Cotter Pin	2
32	7-3522	Anti-Scalp Cup	1
33	33-4750	Blade	1
34	47-0090	Spindle Shaft	1
35	47-0110	Spacer — Spindle	1
36	32120-11	Ring — Retaining Internal	1
37	47-0120	Spindle Tube	1
38	283-2	Pin — Clevis	2
39	32151-57	Ring — Retaining External	2
40	47-1240	Channel — Deck Engagement	1
41	47-1600	Cutter Deck	1
42	47-1900	Spacer — Deck Brake Support	2
43	32120-18	Ring — Retaining External	2
44	47-1610	Support Deck Brake Assembly (Incl. Ref. #6 & 7)	1
45	40-6230	Spring — Torsional	1
46	47-1150	Hub — Adjusting	1
47	3218-3	Nut — Jam	1
48	47-1130	Rod — Adjusting	1

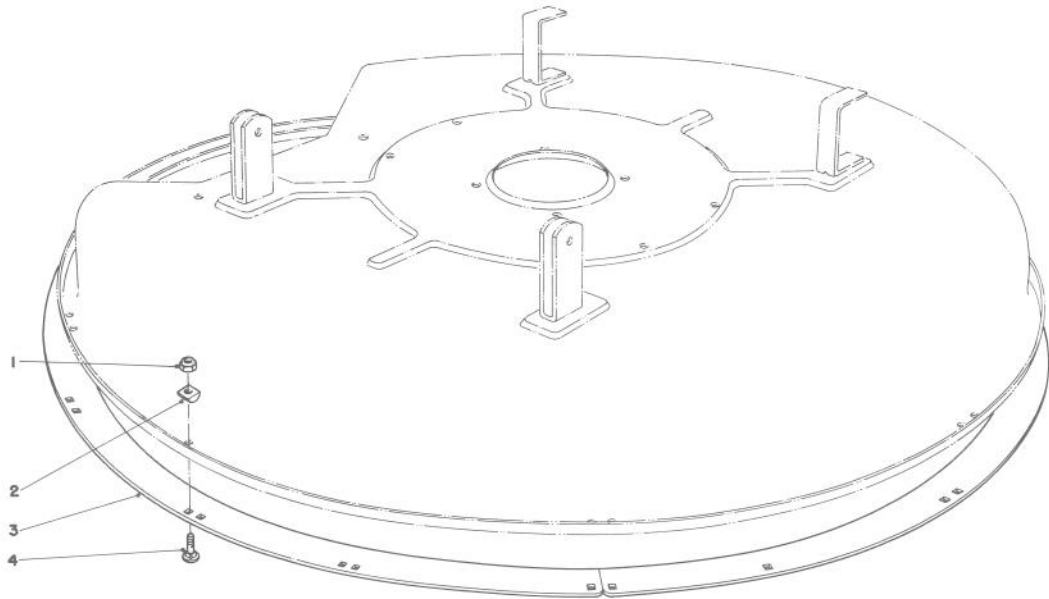

WET GRASS BAGGING KIT NO. 38-5730 (Optional)

Ref. No.	Part No.	Description	No. Used
1	3296-29	Locknut	12
2	38-5690	Spacer — Deck Ring	12

Ref. No.	Part No.	Description	No. Used
3	38-6030	Ring — Deck	4
4	3230-2	Carriage Bolt	12

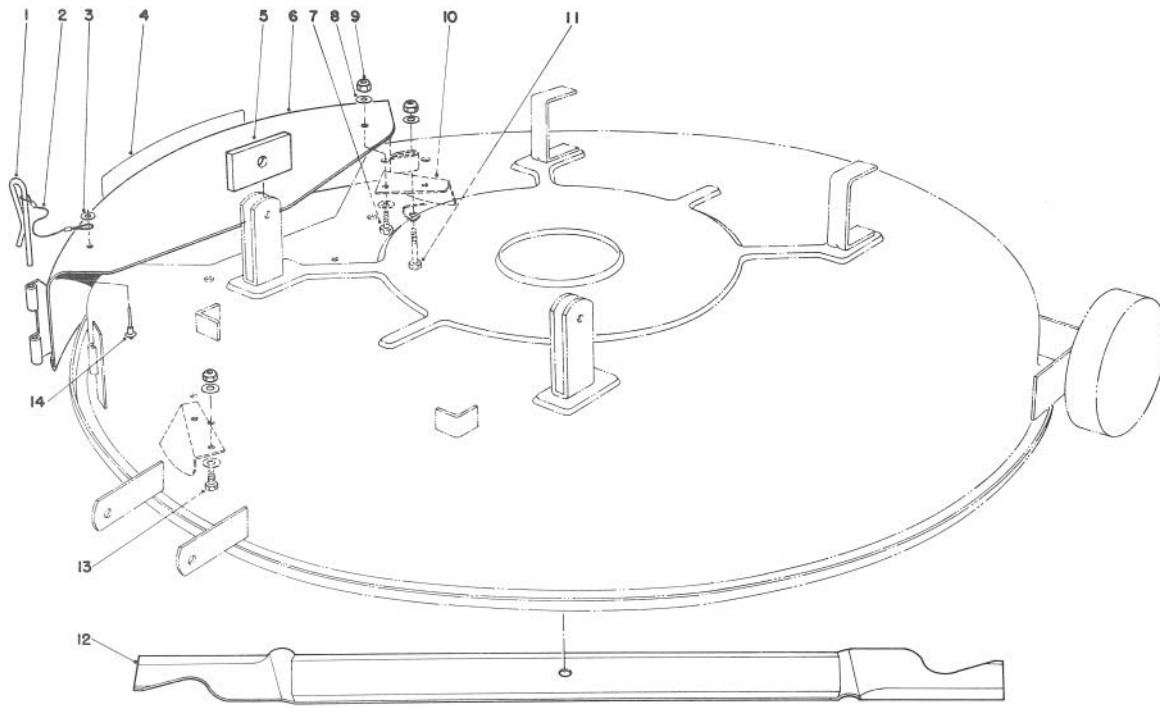

MULCHER KIT MODEL 59155 (Optional)

Ref. No.	Part No.	Description	No. Used
1	28-8130	Pin — Chute Locking	1
2	28-8070	Lanyard	1
3	3256-49	Washer	1
4	44-5910	Decal — Mulcher Cover	1
5	44-5820	Spacer — Deck Angle	2
6	44-5700	Cover — Mulcher Assembly (Incl. Ref. #1-4 & 14)	1
7	322-5	Capscrew — Hex Head	1

Ref. No.	Part No.	Description	No. Used
8	3256-23	Washer	9
9	3296-29	Locknut	5
10	44-5810	Kicker	2
11	322-10	Capscrew — Hex Head	1
12	39-3480	Blade — Mulcher	1
13	322-3	Capscrew — Hex Head	3
14	3290-282	Rivet — Pop	1

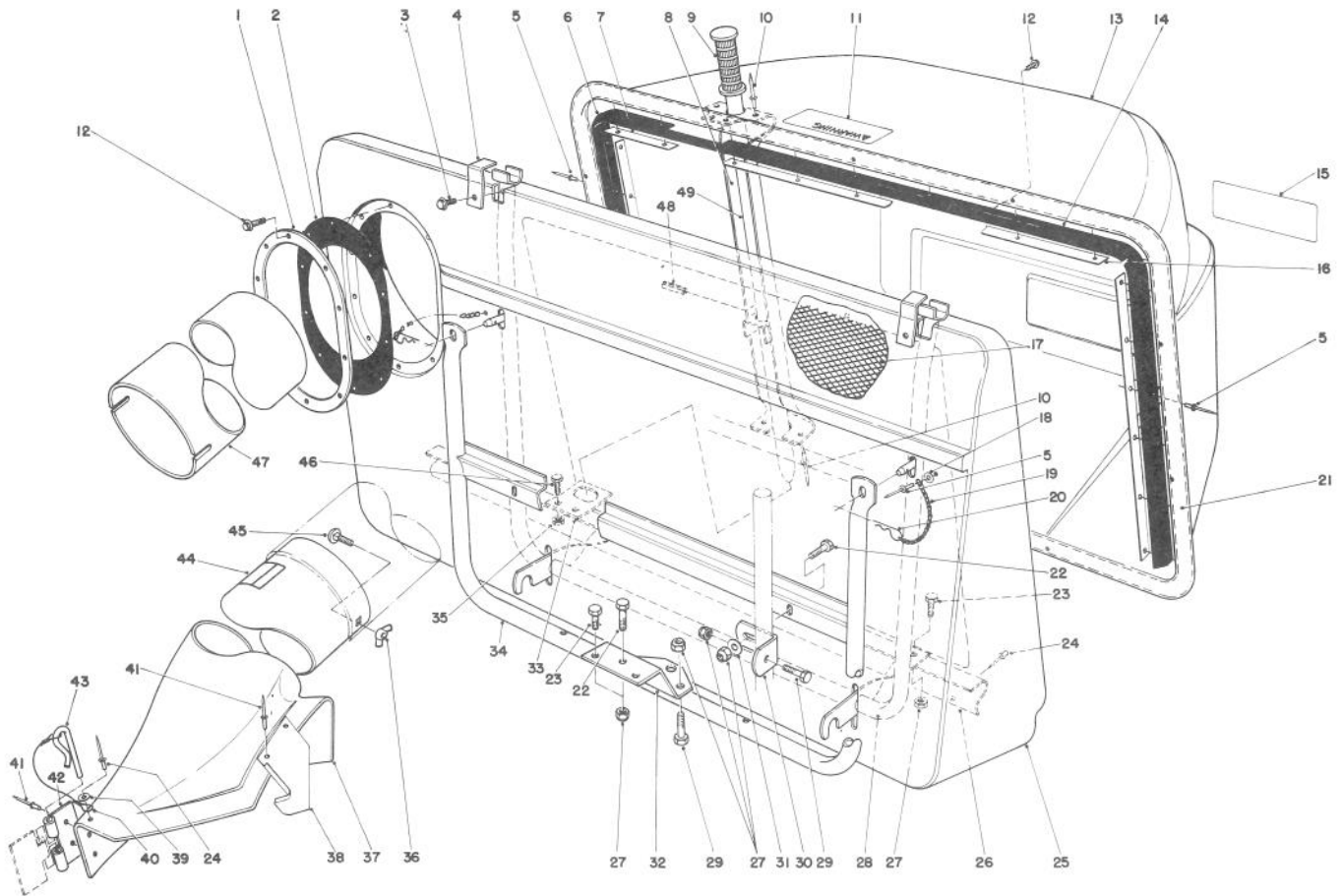

EASY-EMPTY GRASS CATCHER MODEL 59111 (Optional)

Ref. No.	Part No.	Description	No. Used
1	28-7760	Ring — Retainer	1
2	28-7770	Ring — Retainer Rubber	1
3	32104-60	Screw — Hex Hd. Self Tapping	2
4	28-7700	Retainer Pivot Bracket	2
5	3290-415	Domed Head Rivet	22
6	36-2520	Seal — Bag R.H.	1
7	29-5540	Retainer — Ext. Top	1
8	38-2920	Channel — Dump Handle	1
9	233-40	Grip Handle	1
10	3290-409	Domed Head Rivet	16
11	55-7270	Decal — Warning	1
12	32104-76	Screw — Self Tapping	18
13	36-2120	Grass Basket — Rear	1
14	36-2530	Seal — Bag L.H.	1
15	25-2200	Decal	1
16	29-5550	Retainer — Ext. Bag	3
17	28-7840	Screen — Bag	1
18	5-1254	Washer	2
19	2830-10	Chain	2
20	3290-355	Hair Pin Cotter	2
21	28-7670	Frame — Bag Support	1
22	322-5	Capscrew — Hex Hd.	3
23	322-2	Capscrew — Hex Hd.	4
24	3290-282	Rivet	6
25	28-7810	Bag Front	1
26	28-7830	Frame Support Bracket	1

Ref. No.	Part No.	Description	No. Used
27	32152-1	Locknut	11
28	28-7710	Bag Frame	1
29	322-7	Capscrew — Hex Hd.	4
30	47-2020	Bracket — Mtg. Grass Catcher	2
31	3256-23	Washer — Plain	2
32	51-2970	Bracket — Mtg. Grass Catcher	1
33	28-7820	Hanger — Frame Tower	1
34	28-7780	Bag Support	1
35	32152-4	Locknut	2
36	32103-14	Wing Nut	2
37	28-8060	Chute Assembly (Incl. Ref. #24, 38-44)	1
38	33-2090	Bracket — Chute Support	1
39	3256-49	Washer	1
40	28-8070	Lanyard	1
41	3290-412	Rivet	4
42	28-8050	Bracket — Chute Mounting	1
43	28-8130	Pin — Chute Locking	1
44	54-9220	Decal — Danger	1
45	3229-1	Carriage Bolt	2
46	321-3	Capscrew — Hex Hd.	2
47	47-7210	Duct	1
48	32121-79	Roll Pin	1
49	29-5470	Dump Handle	1
*	11-4569	Loose Parts	1

*Not Illustrated

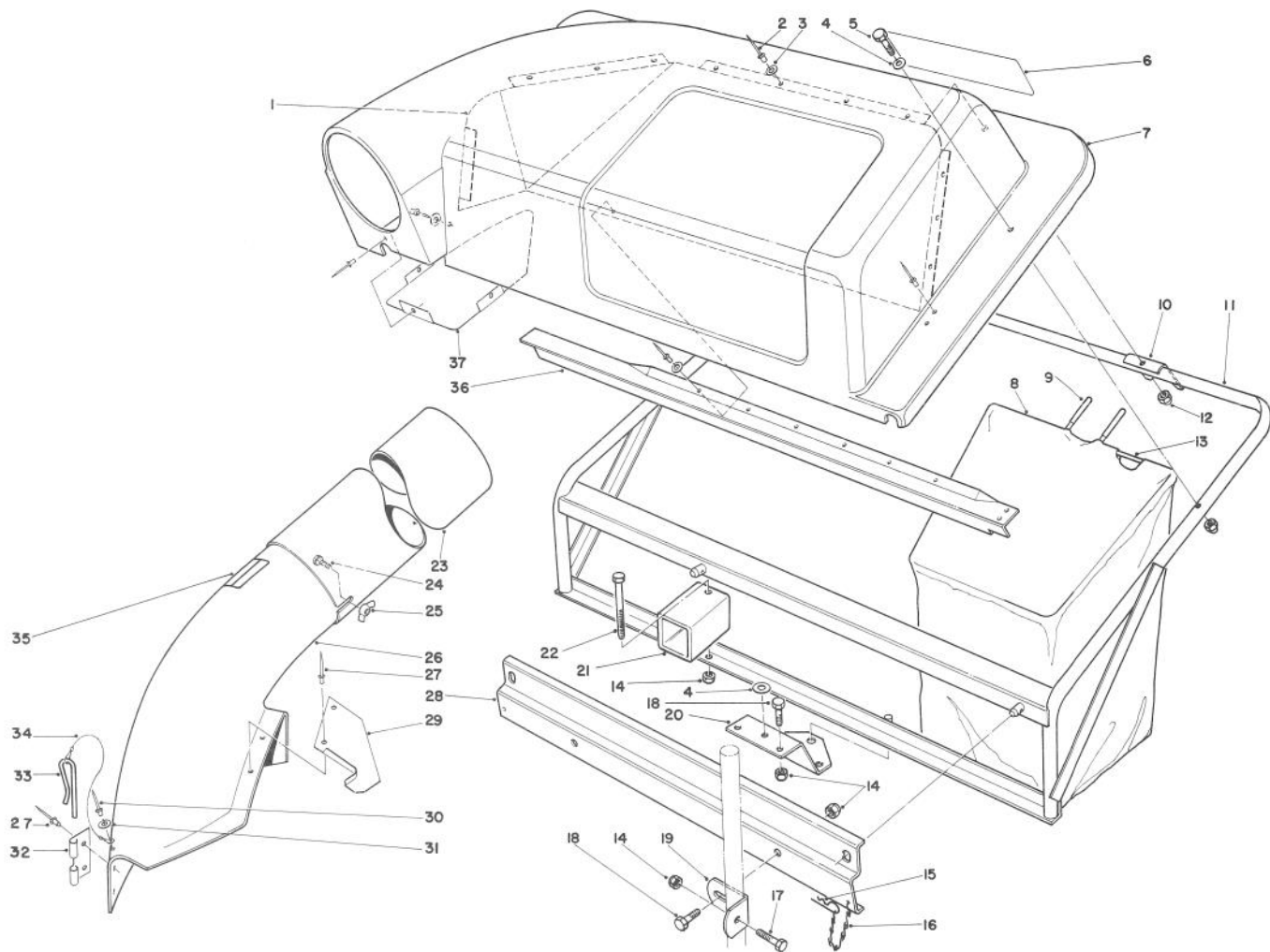

TWIN BAGGER GRASS CATCHER MODEL NO. 59122 (Optional)

Ref. No.	Part No.	Description	No. Used
1	36-4230	Screen — Cover	1
2	3296-4	Rivet — Pop	23
3	3256-14	Washer — Plain	19
4	3256-23	Washer — Plain	4
5	322-17	Screw — Cap Hex Hd.	4
6	47-6890	Decal — Twin Bagger	1
7	47-2190	Cover	1
8	47-2560	Bag — Twin Bagger (Incl. Ref. #9 & 13)	2
9	47-2550	Grip — Bag Handle	2
10	47-2580	Bracket — Bag Frame	2
11	47-2630	Frame	1
12	32111-8	Nut — Acorn	4
13	47-2620	Frame — Bag	1
14	32152-1	Nut — Lock	8
15	3290-355	Hair Pin Cotter	2
16	2830-9	Chain	2
17	322-7	Capscrew	2
18	322-2	Capscrew	5
19	47-2020	Bracket — Mtg. Grass Catcher	2
20	51-2970	Plate — Mtg. Grass Catcher	1

Ref. No.	Part No.	Description	No. Used
21	51-2960	Tube — Frame Support	1
22	322-10	Screw — Cap. Hex Hd.	1
23	47-7210	Duct	1
24	3229-1	Carriage Bolt	2
25	32103-14	Nut — Wing	2
26	28-8060	Chute Assembly (Incl. Ref. #27, 29-35)	1
27	3290-412	Pop Rivet	4
28	36-4550	Bracket — Frame Support	1
29	33-2090	Bracket Chute Support	1
30	3290-282	Pop Rivet	1
31	3256-49	Washer — Plain	1
32	28-8050	Bracket Chute Mounting	1
33	28-8130	Pin — Chute Locking	1
34	28-8070	Lanyard	1
35	54-9220	Decal — Danger	1
36	47-2650	Bracket — Screen Support	1
37	47-6760	Shield — Cover	1
*	11-5459	Loose Parts	1
*	505-78	Adhesive — Plastic	1

*Not Illustrated

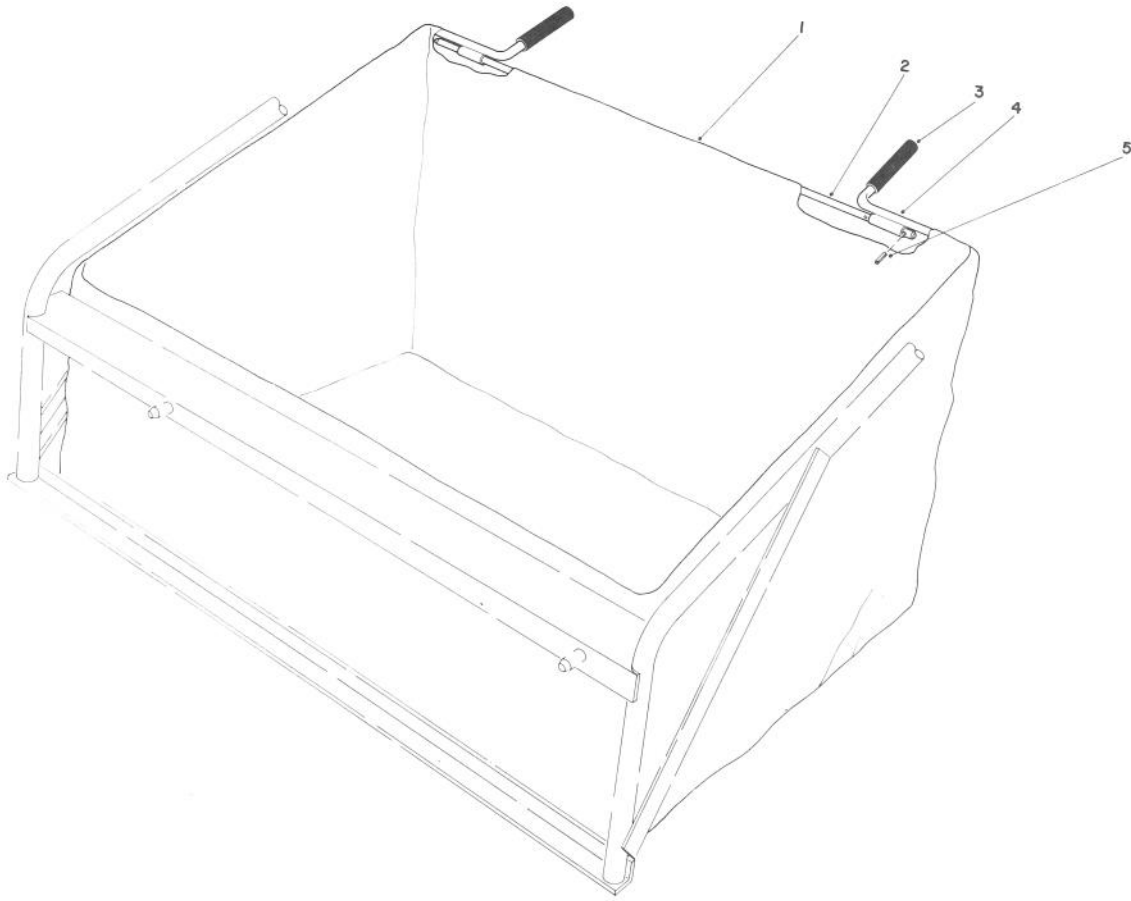

LEAF BAG MODEL NO. 59123 (Optional)

Ref. No.	Part No.	Description	No. Used
1	47-6860	Bag — Leaf Catcher	1
2	47-6800	Rod — Bag Frame	1
3	47-6710	Grip — Leaf Bag Handle	2
4	47-6830	Bag Frame	1

Ref. No.	Part No.	Description	No. Used
5	32121-73	Rollpin	2
*	505-78	Adhesive — Plastic	1
*	47-7550	Bag (Complete)	1

*Not Illustrated

ENGINE BRIGGS & STRATTON MODEL NO. 191702-2132-01

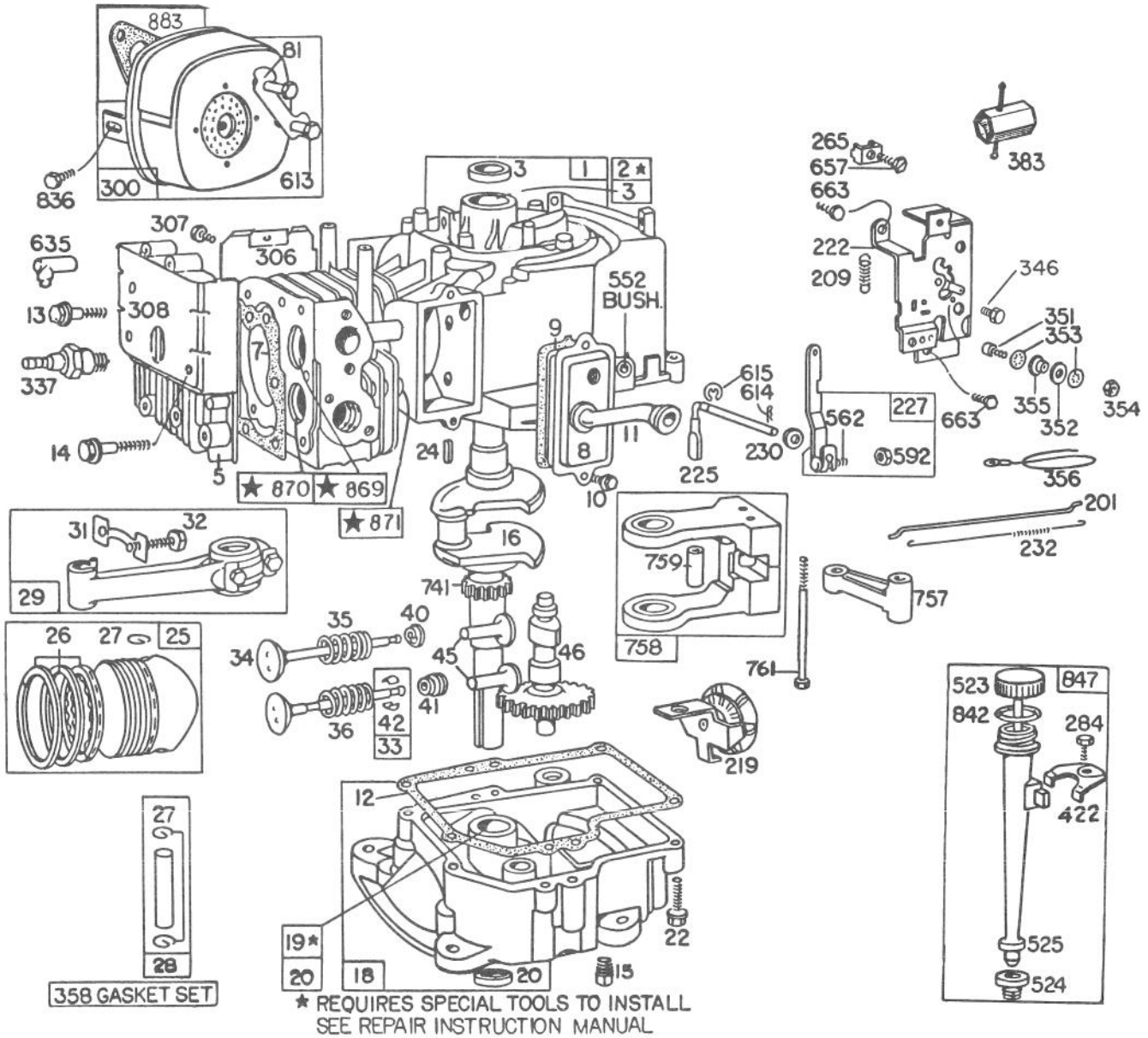

ENGINE BRIGGS & STRATTON MODEL NO. 191707-2132-01

Ref. No.	Part No.	Description	No. Used
1	396269	Cylinder Assembly	1
2	391726	Bushing — Cylinder Note: Requires special tools for installation.	1
3	294606	Seal — Oil	1
5	212286	Head — Cylinder	1
7	*270430	Gasket — Cylinder Head	1
8	299848	Breather Assembly	1
9	*27803	Gasket — Valve Cover	1
10	93394	Screw	1
11	280005	Tube — Breather	1
12	*27750	Gasket — Crankcase Cover — 1/64" thick	1
	*27876	Gasket — Crankcase Cover — .005" thick	1
	*27877	Gasket — Crankcase Cover — .009" thick	1
13	93211	Screw — Cylinder Head (2-21/32" long)	1
14	93723	Screw — Cylinder Head (3" long) 1 Req'd.	1
15	91084	Plug — Oil Drain	1
16	390370	Crankshaft	1
18	392548	Sump — Oil	1
19	295963	Bushing — Oil Sump Note: Requires special tools for installation.	1
20	391086	Seal — Oil	1
22	93585	Screw — Sump Mtg.	1
24	222698	Key — Flywheel	1
25	391673	Piston Assy. — Std.	1
	391674	Piston Assy. — .010" O.S.	1
	391675	Piston Assy. — .020" O.S.	1
	391676	Piston Assy. — .030" O.S.	1
		Piston Ring Sets Note: For Chrome Piston Ring Set — Standard Size — Order No. 299743.	
26	391669	Ring Set — Piston — Std.	1
	391670	Ring Set — Piston — .010" O.S.	1
	391671	Ring Set — Piston — .020" O.S.	1
	391672	Ring Set — Piston — .030" O.S.	1
27	68546	Lock — Piston Pin	1
28	295840	Pin Assy. — Piston — Std.	1
	295841	Pin Assy. — Piston — .005" O.S.	1
29	390402	Rod Assy. — Connecting Note: For Connecting Rod with .020" Undersize Crankpin Bore — Order No. 390773.	1
31	222114	Lock — Conn. Rod Screw	1
32	92659	Screw — Conn. Rod	1
33	390419	Valve — Exhaust	1
34	261055	Valve — Intake	1
35	65906	Spring — Intake Valve	1
36	26828	Spring — Exhaust Valve	1
40	221596	Retainer — Intake Valve	1
41	292260	Rotocoil — Exhaust Valve	1
42	93630	Retainer — Exhaust Valve	1
		Rotocoil	2
45	260933	Tappet — Valve	1

Ref. No.	Part No.	Description	No. Used
46	211689	Gear — Cam	1
81	222263	Lock — Screw	1
201	260971	Link — Governor	1
209	260871	Spring — Gov.	1
219	392718	Oil Slinger — Gov. Gear and Bracket Assembly	1
222	390662	Plate — Gov. Control	1
225	231058	Crank — Governor (1/4" Dia.)	1
227	391733	Lever Assy. — Governor For 1/4" Dia. Crank	1
230	222450	Washer — Gov. Lever (1/4" I.D.)	1
232	260584	Spring — Governor Link	1
265	221535	Clamp — Casing	1
284	93804	Screw — Clamp Mtg.	1
300	391313	Muffler — Exhaust	1
306	222830	Shield — Cylinder	1
307	93163	Screw — Cylinder Shield Mtg.	1
308	222636	Cover — Cylinder Head	1
337	293918	Plug — Spark (1-1/2" high — 37 M.M.) (Resistor Type)	1
346	93705	Screw	1
351	93735	Screw — Terminal	1
352	66068	Washer — Insulating	1
353	92791	Washer — Lock	3
354	90576	Nut — Hex	2
355	66554	Collar — Insulating	1
356	299500	Wire — Ground	1
358	299577	Gasket Set	1
383	89838	Spark Plug Wrench	1
422	222502	Clamp — Oil Filler Tube	1
523	391840	Cap and Dipstick — Oil Filler	1
524	68838	Seal — Filler Tube	1
525	280133	Tube — Oil Filler	1
552	231055	Bushing — Gov. Crank (1/4" I.D.)	1
562	92613	Bolt — Governor Lever	1
592	231082	Nut — Hex	1
613	93704	Screw — Muffler	1
614	93306	Cotter — Hair Pin	1
615	93307	Retainer — E-Ring	1
635	66538	Elbow — Spark Plug	1
657	93496	Screw	1
663	93572	Screw	1
741	261195	Gear — Timing	1
757	212359	Link — Counterweight	1
758	390172	Counterweight Assy.	1
759	298909	Pin — Counterweight	1
761	93874	Screw — Counterweight	1
836	93559	Screw	1
842	270920	Seal — Filler Cap	1
847	392066	Filler Group — Oil	1
869	211661	Seat — Intake Valve (Std.)	1
870	211661	Seat — Exhaust Valve (Std.)	1
871		Guide — Exhaust Valve 231218 or 230655 See Repair Manual	1
883	270918	Gasket — Exhaust Pipe	1
†	392195	Spark Arrestor Muffler (Includes Deflector and 4 Mounting Screws)	1

*Included in Gasket Set — Part No. 299577.

†Optional Equipment.

ENGINE BRIGGS & STRATTON MODEL NO. 191707-2132-01

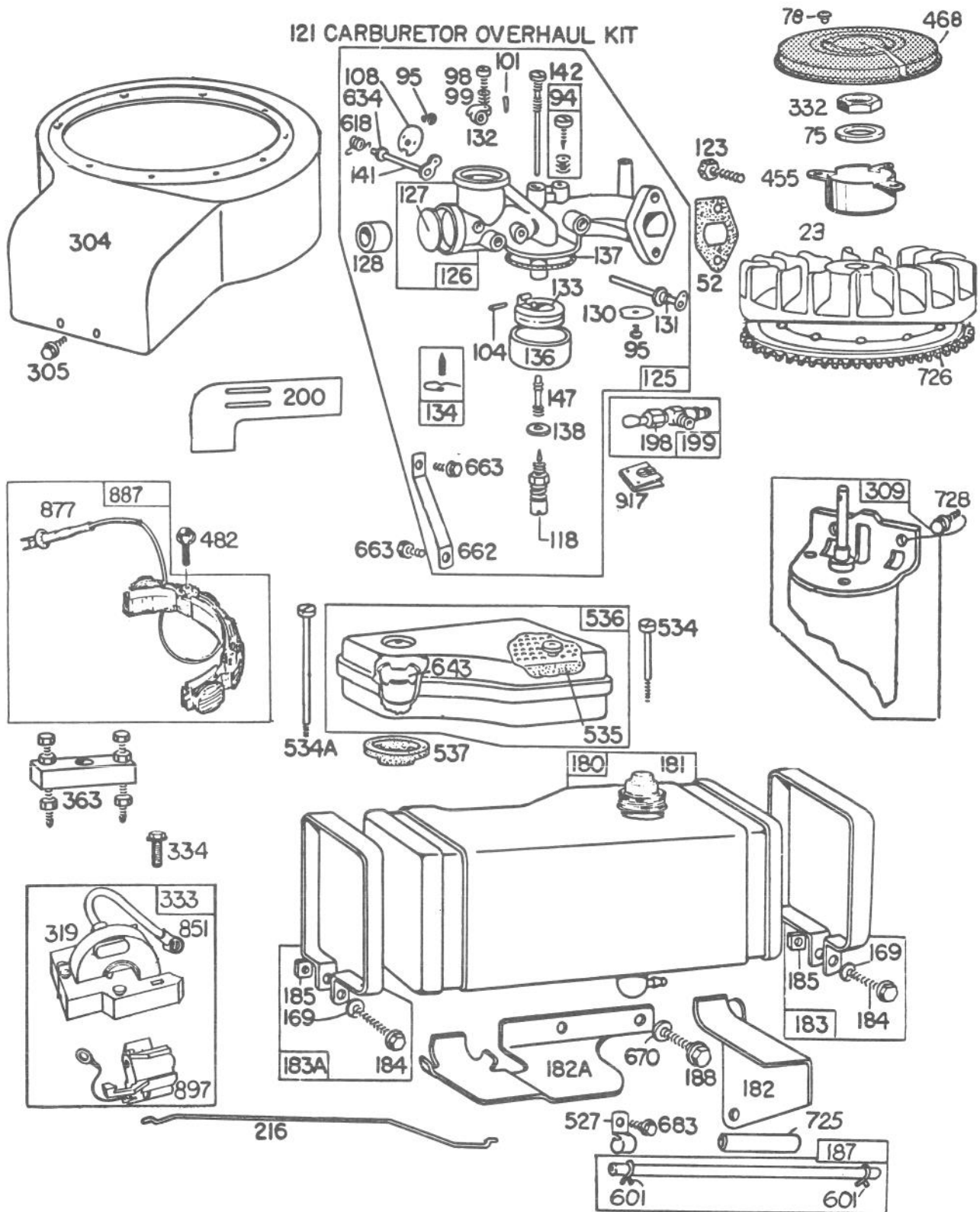

ENGINE BRIGGS & STRATTON MODEL NO. 191707-2132-01

Ref. No.	Part No.	Description	No. Used
23	391983	Flywheel and Ring Gear Assy. — Magneto	1
52	†270538	Gasket — Carburetor Mtg.	1
75	220865	Washer — Spring	1
78	93805	Screw	1
94	†292681	Valve Assembly — Carburetor Idle	1
95	93499	Screw — Throttle and Choke Valve Mtg.	1
98	91920	Screw — Machine, Fill. Hd.	1
99	26157	Spring — Throttle Adjustment	1
101	93043	Pin — Throttle Stop	1
104	†230896	Pin — Float Hinge	1
108	222010	Valve — Choke	1
118	†391233	Valve — Needle	1
121	394698	Carburetor Overhaul Kit	1
123	93357	Screw — Carburetor Mtg.	1
125	390811	Carburetor Assembly	1
126	299851	Body Assembly Carburetor	1
127	†221997	Plug — Welch	1
128	211682	Venturi — Carburetor	1
130	221986	Valve — Throttle	1
131	391512	Shaft and Lever — Throttle	1
132	211712	Stop — Throttle	1
133	299707	Float — Carburetor	1
134	†394681	Valve — Fuel Inlet	1
136	221995	Bowl — Float	1
137	†270511	Gasket — Float Bowl	1
138	†222014	Washer — Float Bowl	1
141	390684	Shaft and Lever — Choke	1
142	†299740	Nozzle — Carburetor	1
147	†230932	Screw — Nozzle	1
169	90832	Washer — Lock	1
180	390225	Tank Assy. — Fuel — (3 Quart)	1
181	392300	Cap — Fuel Tank	1
182	222813	Bracket — Fuel Tank (R.H.)	1
182A	222112	Bracket — Fuel Tank (L.H.)	1
183	390406	Strap Assy. — Fuel Tank (R.H.)	1
183A	390405	Strap Assy. — Fuel Tank (L.H.)	1
184	93803	Screw — Hex Hd.	1
185	90970	Nut — Square,	1

Ref. No.	Part No.	Description	No. Used
187	296004	Line — Fuel (23" long)	1
188	93535	Screw	1
198	293934	Valve — Fuel Shut-Off	1
199	390303	Connector — Fuel Pipe	1
200	221760	Guide — Air	1
216	261117	Link — Choke	1
304	299392	Housing — Blower	1
305	93158	Screw — Blower Housing Mounting	1
309		Motor — Starting (12 Volt)	1
319	395326	Armature Assy. (Less Trigger Coil)	1
332	92284	Nut — Flywheel	1
333	395492	Armature Assembly	1
334	93381	Screw — Armature Mtg.	1
363	19165	Puller — Flywheel	1
455	222561	Cup — Screen Mounting	1
468	222562	Screen — Flush Rotating	1
482	93621	Screw	1
527	221428	Clamp	2
534	93622	Screw — Air Cleaner	1
534A	93323	Screw — Air Cleaner	1
535	270528	Element — Air Cleaner	1
536	390379	Cleaner Assy. — Air	1
537	270539	Gasket — Air Cleaner	1
601	93053	Clamp — Fuel Pipe	1
618	261116	Spring — Choke Return	1
634	270382	Washer — Choke Shaft	1
643	222149	Cup — Air Cleaner	1
662	222027	Bracket — Carburetor	1
663	93572	Screw	1
670	22963	Spacer — Fuel Tank	1
683	93572	Screw	1
725	222175	Shield — Fuel Pipe, Heat	1
726	392134	Gear — Ring (Aluminum) (Includes Mtg. Parts)	1
728	93523	Screw	1
851	221798	Terminal — Ignition Cable	1
877	393814	Diode and Connector Assy.	1
887	391529	Stator Assembly — Alternator (D.C.)	1
897	394970	Trigger Coil	1
917	223271	Valve Handle — Fuel Shut-Off	1

†Included in Carburetor Overhaul Kit — Part No. 394698.

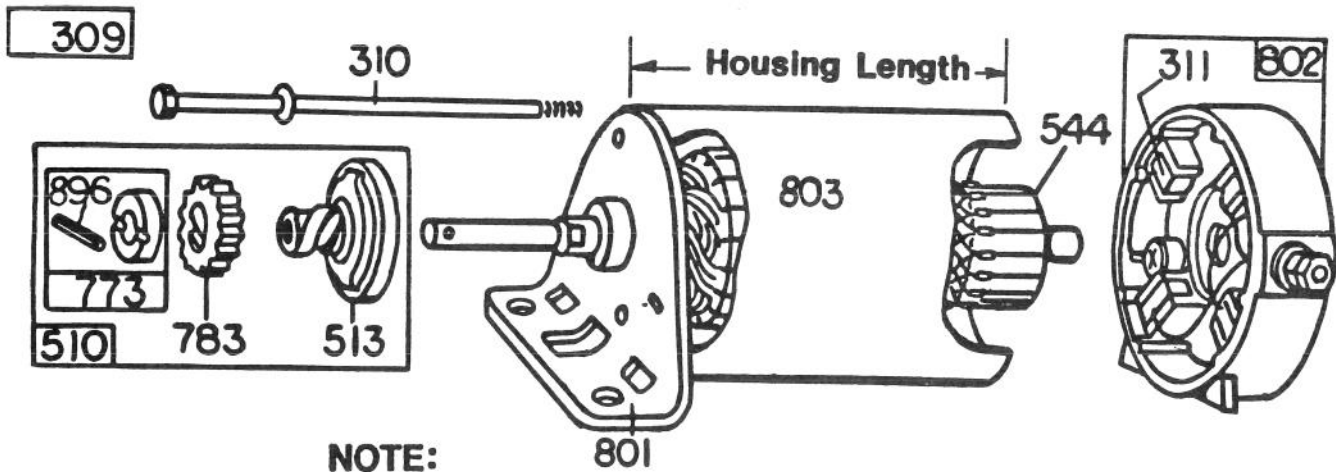

NOTE:
**To identify Briggs & Stratton manufactured
 starter motors, measure the housing length.**

ENGINE BRIGGS & STRATTON MODEL NO. 191707-2132-01

Ref. No.	Part No.	Description	No. Used
309	394805	Motor and Drive Assembly	1
310	94003	Thru Bolt Assembly	2
311	395538	Brush Assembly	2
510	391461	Drive Assembly	1
513	391135	Clutch Assembly	1
544	392747	Armature Assembly	1
773	391462	Retainer and Pin	1

Ref. No.	Part No.	Description	No. Used
783	280104	Gear	1
801	394856	End Cap Assembly Drive	1
802	395537	End Cap Assembly Commutator	1
803	393825	Housing Assembly	1
896	93754	Roll Pin	1

PRODUCT CHANGES

In an effort to make improvements available to TORO owners as quickly as possible, minor changes are incorporated into Toro's products from time to time that do not become immediately shown in the Parts Catalog. If such a change apparently has been made in your unit, which is not reflected in your manual, see your TORO Distributor or his Authorized TORO Service Dealer for information and part numbers.

IDENTIFICATION AND ORDERING

MODEL AND SERIAL NUMBERS

The Rider has two identification numbers; a model number and a serial number. The two numbers are stamped on a decal which is located on the left side of frame in front of rear wheel. In any correspondence concerning the mower, supply model and serial numbers to assure that correct information and replacement parts are obtained.

To order replacement parts from an Authorized TORO Service Dealer, supply the following information:

1. Model and serial numbers of the rider.
2. Part number, description, and quantity of part(s) desired.

Note: Do not order by reference number if a parts catalog is being used; use the PART NUMBER.

The Toro Promise

A TWO YEAR LIMITED WARRANTY

The Toro Company promises to repair your TORO Product if defective in materials or workmanship. The following time periods from the date of purchase apply:

Residential Product 2 Years
Residential Products Used Commercially 45 Days

The costs of parts and labor are included, but the customer pays the transportation costs. Just return any residential product to an Authorized TORO Service Dealer or TORO Distributor.

Should you feel your TORO Product is defective and wish to rely on The Toro Promise, the following procedure is recommended:

1. Contact any Authorized TORO Service Dealer, TORO Master Service Dealer, or TORO Distributor (the Yellow Pages of your telephone directory is a good reference source).
2. He will either instruct you to return the product to him or recommend another Authorized TORO Service outlet which might be more convenient.
3. Bring the product along with your original sales slip, or other evidence of purchase date, to the service dealer.
4. The servicing dealer will inspect the unit, advise you whether the product is defective and, if so, make all repairs necessary to correct the defect without extra charge to you.

If for any reason you are dissatisfied with the dealer's analysis of the defect or the service performed, you may contact us.

Write:

TORO Consumer Service Department
8111 Lyndale Avenue South
Minneapolis, Minnesota 55420

The above remedy of product defects through repair by an Authorized TORO Service Dealer is the purchaser's sole remedy for any defect.

THERE IS NO OTHER EXPRESS WARRANTY. ALL IMPLIED WARRANTIES OF MERCHANTABILITY AND

FITNESS FOR USE ARE LIMITED TO THE DURATION OF THE EXPRESS WARRANTY.

Some states do not allow limitations on how long an implied warranty lasts, so the above limitation may not apply to you.

This warranty applies only to parts or components which are defective and does not cover repairs necessary due to normal wear, misuse, accidents, or lack of proper maintenance. Regular, routine maintenance of the unit to keep it in proper operating condition is the responsibility of the owner.

All warranty repairs reimbursable under The Toro Promise must be performed by an Authorized TORO Service Dealer using Toro approved replacement parts.

Repairs or attempted repairs by anyone other than an Authorized TORO Service Account are not reimbursable under The Toro Promise. In addition, these unauthorized repair attempts may result in additional malfunctions, the correction of which is not covered by warranty.

THE TORO COMPANY IS NOT LIABLE FOR INDIRECT, INCIDENTAL OR CONSEQUENTIAL DAMAGES IN CONNECTION WITH THE USE OF THE PRODUCT INCLUDING ANY COST OR EXPENSE OF PROVIDING SUBSTITUTE EQUIPMENT OR SERVICE DURING PERIODS OF MALFUNCTION OR NON-USE.

Some states do not allow the exclusion or limitation of incidental or consequential damages, so the above limitation or exclusion may not apply to you.

This warranty gives you specific legal rights, and you may also have other rights which vary from state to state.

COUNTRIES OTHER THAN THE UNITED STATES OR CANADA

Customers who have purchased TORO products exported from the United States or Canada should contact their TORO Distributor (Dealer) to obtain guarantee policies for your country, province or state. If for any reason

you are dissatisfied with your Distributor's service or have difficulty obtaining guarantee information, contact the TORO importer. If all other remedies fail, you may contact us at The Toro Company.

