



# **Reelmaster® Universal Frame**

## **3, 5 & 7 Unit**

**Model No. 33145—240000001 & Up**

**Model No. 33155—240000001 & Up**

**Model No. 33165—240000001 & Up**

**Operator's Manual**

# Contents

	<b>Page</b>
Introduction .....	2
Safety .....	3
Safe Operating Practices .....	3
Specifications .....	4
General Specifications .....	4
Setup .....	5
Loose Parts .....	5
3 Unit Assembly .....	7
3 To 5 Unit Conversion .....	7
5 To 7 Unit Conversion .....	8
Operation .....	8
Install Tractor Hitch Extension .....	8
Adjusting Hitch Height .....	8
Proper Frame Use .....	8
Optional Trailing Kits .....	9
Maintenance .....	10
Lubrication .....	10
Frame Inspection .....	10
The Toro General Commercial Products Warranty ...	12

# Introduction

Read this manual carefully to learn how to operate and maintain your product properly. The information in this manual can help you and others avoid injury and product damage. Although Toro designs and produces safe products, you are responsible for operating the product properly and safely.

Whenever you need service, genuine Toro parts, or additional information, contact an Authorized Service Distributor and have the model and serial numbers of your product ready. The numbers are stamped into a plate on the frame.

Write the product model and serial numbers in the space below:

<b>Model No.</b> _____
<b>Serial No.</b> _____

This manual identifies potential hazards and has special safety messages that help you and others avoid personal injury and even death. **Danger**, **Warning**, and **Caution** are signal words used to identify the level of hazard. However, regardless of the hazard, be extremely careful.

**Danger** signals an extreme hazard that *will* cause serious injury or death if you do not follow the recommended precautions.

**Warning** signals a hazard that *may* cause serious injury or death if you do not follow the recommended precautions.

**Caution** signals a hazard that may cause minor or moderate injury if you do not follow the recommended precautions.

This manual uses two other words to highlight information. **Important** calls attention to special mechanical information and **Note:** emphasizes general information worthy of special attention.

# Safety

**Improper use or maintenance by the operator or owner can result in injury. To reduce the potential for injury, comply with these safety instructions and always pay attention to the safety alert  symbol, which means CAUTION, WARNING, or DANGER—“personal safety instruction.” Failure to comply with the instruction may result in personal injury or death.**

## Safe Operating Practices

- Operate the machine only after reading and understanding the contents of this manual. A replacement manual is available by sending complete model and serial number to:  
The Toro Company  
8111 Lyndale Ave. S.,  
Bloomington, MN 55420–1196.
- Keep all shields, safety devices and decals in place. If a shield, safety device or decal is damaged or illegible, repair or replace it before operating the machine.
- Always wear substantial shoes. Do not operate machine while wearing sandals, tennis shoes or sneakers. Do not wear loose fitting clothing because it could get caught in moving parts and possibly cause personal injury.
- Never carry passengers on either the tractor or the frame.
- Using the machine demands attention and to prevent loss of control:
  - Operate only in daylight or when there is good artificial light.
  - Drive slowly. Avoid sudden stops and starts.
  - Watch for holes or other hidden hazards.
  - Do not drive close to a sand trap, ditch, creek or other hazard.
  - Reduce speed when making sharp turns and turning on a hillside.
  - Do not exceed 6 MPH (9.7 Km/hr) during mowing or transport operation. Operate more slowly while traveling over rough terrain or in adverse weather conditions.
- Make sure frame is parked on a level surface when disconnecting from tow tractor so it does not move.
- Refer to Operator’s Manual for tractor or tow unit for complete operating and safety instructions pertaining to that unit.
- If major repairs are ever needed or if assistance is desired, contact an Authorized Toro Distributor.
- To insure optimum performance and safety, use genuine TORO replacement parts and accessories. Replacement parts and accessories made by other manufacturers could be dangerous, and such use could void the product warranty of The Toro Company.

# Specifications

## General Specifications

Cutting Units	3, 5 and 7		
Width of Cut	3 Unit – approximately 7' 5 Unit – approximately 11' 7 Unit – approximately 16'		
Overall Width–Cutting Position	Mowers with Iron Wheels		Mowers with Rubber Wheels
	3 Unit	7'10"	8'2"
	5 Unit	12'4"	12'8"
7 Unit	16'10"	17'2"	
Overall Length–Cutting Position	3, 5 or 7 Unit	10'	
Cutting Unit	Reelmaster Cutting Unit or Spartan Cutting Unit. Spartan cutting unit will require (2) of 5–1090 drawbar clamp, and fasteners, per unit.		
Frame	Welded, fabricated construction, with structural sections and tubing. Flexible attachment allows mowers to follow contour of terrain; ball socket hinge joints for the number 4 and 5 wing units, with other units utilizing a U–Bolt and eyelet for positive attachment. Conversion kits available to expand frame for 3 to 5 and 5 to 7 cutting units. Each cutting unit rear roller may be raised from ground, for transport. Stand provided, at coupler, for easy attachment to tow tractor. Cutting units may be used with 14 inch to 18 inch diameter wheels.		
Optional Trailing Hitch	Tool less, snap hook, and attachment fasteners, used in place of the u–bolt attachment. This feature allows the frame sections to be placed and track within an eight foot width for transport purposes, and also mow between obstructions with limited distance.		
Optional Ball Coupler Kit	A ball type coupler assembly, and 2–5/16 diameter ball, rated for 9,900 pound capacity. Coupler bolts directly to frame and replaces the standard clevis type hitch. Part No. 53–9760.		

**Note:** Specifications and design subject to change without notice.

# Setup

**Note:** Determine the left and right sides of the machine from the normal operating position.

## Loose Parts

**Note:** Use this chart and figure 1 to ensure that all parts have been received. Without these parts, total setup cannot be completed.

Item No.	Part Description	Application	3 Unit	5 Unit	7 Unit
1	Frame support	Supports center frame when not mounted on tractor	1	1	1
2	Cotter pin, 5/16 x 3"	Secures frame support to center frame	1	1	1
3	Drawbar (stationary)	Attaches cutting units to 3 unit center frame and all trail units	3	3	3
4	Drawbar (pivoting)	Attaches cutting units to all wing units	–	2	2
5	Locknut–1/2–13	Mounts cutting units to drawbar assembly	6	10	14
6	Spacer		6	10	14
7	Capscrew, 1/2–13 x 2–1/2		6	10	14
8	Capscrew, 1/2–13 x 1–1/4	Mounts drawbar assemblies (stationary & pivoting) to center frame, wing and trailing units	12	20	28
9	Locknut, 1/2–13		12	20	28
10	Cotter pin	Secure lift chains to cutting units	3	5	7
11	Shackle		3	5	7
12	Clevis pin, 3/8x1–1/2		3	5	7
13	U–bolt	Connects trailing units to center frame	2	2	2
14	Locknut, 1/2–13		4	4	4
15	Capscrew, 1/2–13 x 1–1/4	Secures center hinge to center frame	–	8	8
16	Locknut, 1/2–13		–	8	8
17	Hinge socket (left)	Mounts left wing unit to center frame	–	2	2
18	Hinge socket (right)	Mounts right wing unit to center frame	–	2	2
19	Grease fitting	Mount to hinge cap	–	4	4
20	Hinge cap	Mount wing units to center frame	–	4	4
21	Hinge clamp bolt		–	4	4
22	Lockwasher – 1/2"		–	4	4
23	Cotter Pin – 3/32 x 3/4"		–	–	4
24	Capscrew, 1/2–13 x 1	Mount wing extensions to wing units	–	–	12
25	Locknut, 1/2–13		–	–	12
26	U–bolt	Mount trailing units to wing extensions	–	–	2
27	Locknut, 1/2–13		–	–	4
28	Pointed hitch pin	Connect hitch to tractor	1	1	1
29	Hairpin cotter		1	1	1
30	Hitch extension	Extends hitch	1	1	1
	Operator's Manual	Read before operation	1	1	1
	Parts Catalog		1	1	1

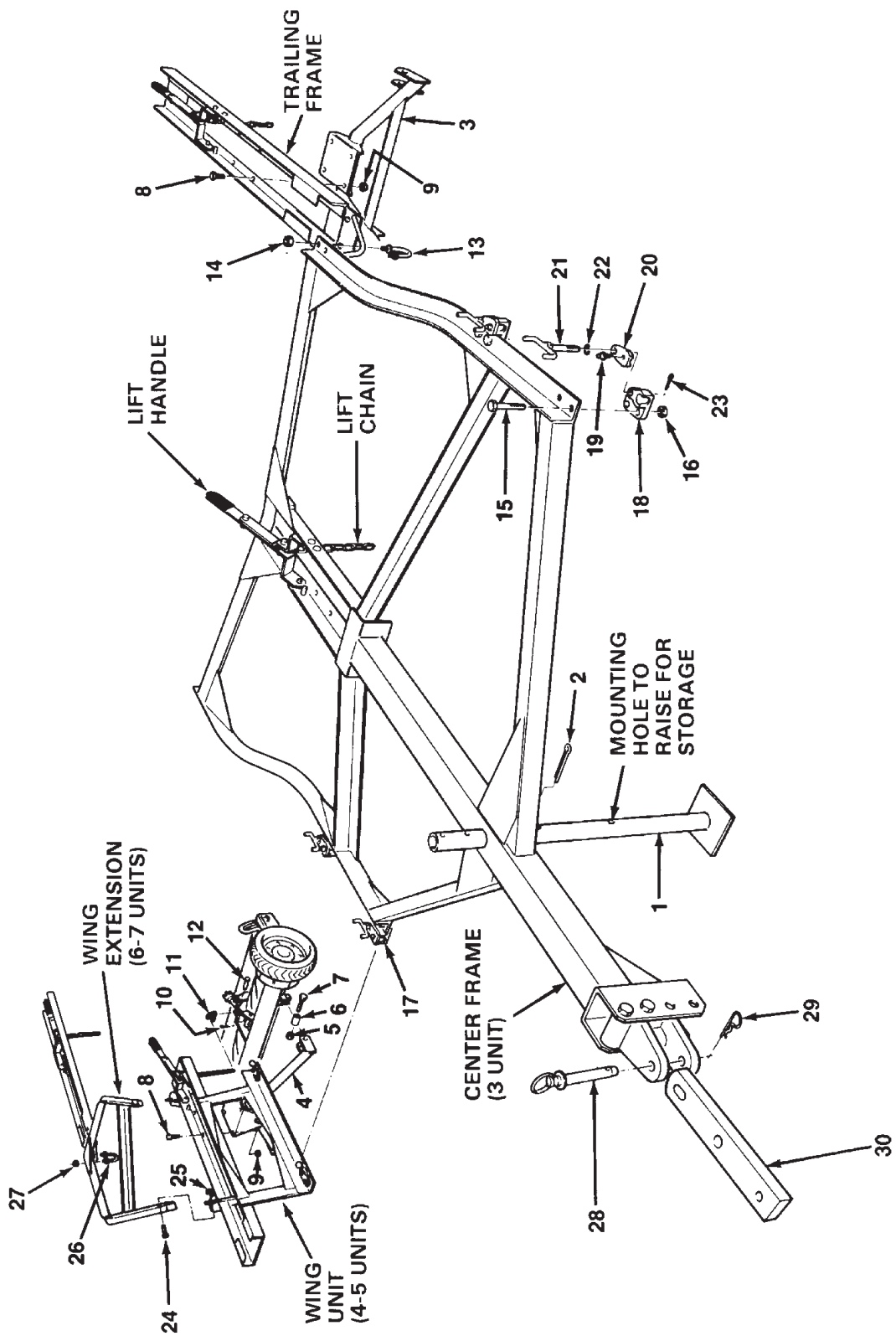

Figure 1

**Note:** Remove parts from shipping container and lay out all hardware and fasteners to ease assembly. Use loose parts chart and illustration to identify and locate parts.

## 3 Unit Assembly

3 UNIT REELMASTER UNIVERSAL FRAME CONTAINS:  
1-Center Frame      2-Trailing Units

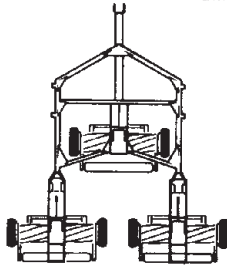

Figure 2

## Install Drawbars to Reelmaster Cutting Units

1. Align holes in stationary (non pivoting) drawbars with brackets on mower crosstube. Secure each side with 1/2-13 x 2-1/2" lg. capscrew, spacer, and 1/2-13 locknut. Position capscrew heads to the inside of brackets when mounting. Use same procedure on remaining stationary drawbars.

**Note:** If Spartan mowers are to be attached, drawbar clamps, part no. 5-1090 and mounting fasteners will be required to mount drawbar to cross tube of mower (Fig. 3). Contact your local Authorized Toro Distributor to order parts or for assistance.

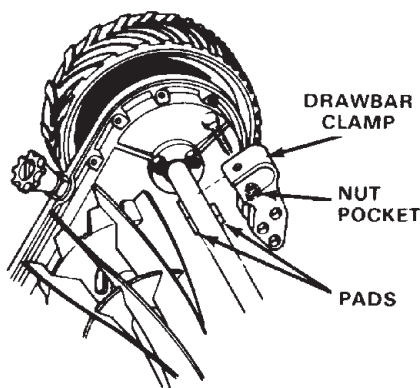

Figure 3

2. Install lift chain to mower with 1/8 x 3/4 cotter pin, shackle and 3/8 x 1-1/2 clevis pin.

## Install Trailing Frames

1. Align mounting holes in trailing frame with holes in drawbar/cutting unit. Secure with 1/2-13 x 1-1/4" lg. capscrews and 1/2-13 locknuts.
2. Install lift chain from trailing unit to mower with 1/8 x 3/4 cotter pin, shackle and 3/8 x 1-1/2 clevis pin. Repeat assembly procedure to remaining trailing units.
3. Connect trailing units to rear corners of center frame with U-bolts and 1/2-13 locknuts.
4. Lubricate all moving parts of frame; refer to lubrication, page 10.

## 3 To 5 Unit Conversion

5 UNIT REELMASTER UNIVERSAL FRAME CONTAINS:  
1-Center Frame      2-Trailing Units  
1-Right Hand Wing Unit      1-Left Hand Wing Unit

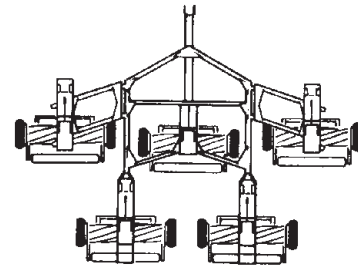

Figure 4

## Install Drawbars to Cutting Units

Align holes in pivoting drawbar with brackets on mower crosstube. Secure each side with 1/2-13 x 2-1/2" lg. capscrew, spacer, and 1/2-13 locknut. Position capscrew head to the inside of bracket when mounting. Use same procedure on remaining pivoting drawbar.

## Install Wing Units

1. Align mounting holes in wing units with mounting holes in drawbar/cutting units. Secure with 1/2-13 x 1-1/4" lg. capscrews and 1/2-13 locknuts.
2. Install lift chains from wing units to mower with 1/8 x 3/4 cotter pins, shackles, and 3/8 x clevis pins.
3. Attach (2) left hand and (2) right hand hinge sockets to respective sides of center frame with 1/2-13 x 1-1/4" lg. capscrews and 1/2-13 locknuts. The ball socket openings should be facing toward the front of the frame.
4. Install a grease fitting into each hinge cap.
5. Install a hinge clamp bolt and lockwasher into each hinge cap.

6. Move wing nuts into position so hinge balls are inserted into hinge sockets.
7. Position hinge caps over hinge balls and tighten hinge clamp bolts. Secure hinge clamp bolt with 3/32 x 3/4 cotter pin.
8. Lubricate all grease fittings and moving parts of frame members; refer to Lubrication, page 10.

## 5 To 7 Unit Conversion

7 UNIT REELMASTER UNIVERSAL FRAME CONTAINS:  
 1-Center Frame                      4-Trailing Units  
 1-Right Hand Wing Unit          1-Left Hand Wing Unit  
 1-Right Hand Wing Extension    1-Left Hand Wing Extension

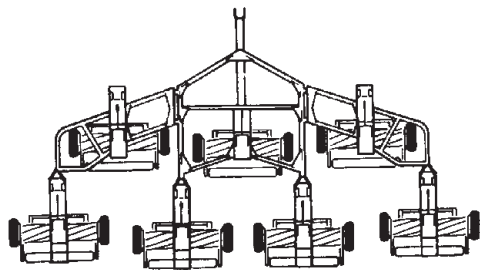

Figure 5

### Mount Wing Extensions to Wing Units

Align mounting holes of right and left wing extensions with mounting holes in respective wing units. Secure with 1/2–13 x 1” lg. capscrews and 1/2–13 locknuts.

### Install Drawbars to Cutting Units

Align holes in stationary (non pivoting) drawbars with brackets on mower crosstube. Secure each side with 1/2–13 x 2–1/2” lg. capscrew, spacer, and 1/2–13 locknut. Position capscrew heads to the inside of brackets when mounting. Use same procedure on remaining stationary drawbars.

### Install Trailing Frames

1. Align mounting holes in trailing frame with holes in drawbar/cutting unit. Secure with 1/2–13 x 1–1/4” lg. capscrews and 1/2–13 locknuts.
2. Install lift chain from trailing unit to mower mounting bracket with 1/8 x 3/4 cotter pin, shackle and 3/8 x 1–1/2 clevis pin. Repeat assembly procedure to remaining trailing units.
3. Connect trailing units to rear corner of each wing extension with U-bolts and 1/2–13 locknuts.
4. Lubricate all moving parts of frame members, refer to Lubrication, page 10.

# Operation

## Install Tractor Hitch Extension

The tractor hitch extension must be installed on all tow vehicles, to allow frame operation on undulating terrain.

Mounting holes must be drilled in hitch extension to accommodate tow vehicle hitch.

## Adjusting Hitch Height

To accommodate varying heights of tractor hitches, the hitch height can be raised or lowered.

1. Be sure the frame is located on a level surface and frame support is adjusted to level frame.
2. Back the tractor up close to the frame hitch to gauge the difference in height between the tractor hitch extension and the frame hitch.
3. If the frame hitch height must be changed, remove the capscrews and locknuts securing hitch to frame. Move hitch to one of the other settings or, if these settings do not exactly match, a more optimal adjustment may be achieved by rotating the hitch 180°.
4. Secure tractor hitch extension to frame hitch with hitch pin and hair pin cotter.
5. Remove cotter pin securing frame support to frame hitch, push frame support up through hitch and re-secure to hitch. Frame support is now in storage position.

## Proper Frame Use

Never exceed 6 MPH (9.66 km/hr) ground speed or quality of cut will be greatly reduced and damage to the frame and mowers more likely to occur. Best quality of cut under most normal conditions is while operating at approximately 4–6 MPH (6.4–9.66 km/hr). Reduce ground speed when turning to be sure the outer mowers do not bounce and skip on the turf.

Before leaving the tractor to adjust the frame or mowers, be sure the tractor and frame is on a level surface, the engine is stopped and the parking brake set. To transport the mowers from one area to another:

1. Disengage the mower reels by rotating the reel throwout knobs outward; refer to the Operators Manual for the mowers.
2. Grasp the handle grip of the lift handles on the frame and rotate each handle 180° forward. This will raise the mower/s rear roller/s off the ground.



**Important** Do not back up tractor with frame attached. If unit must be backed up, each trailing and wing unit must be removed and manually repositioned. Failure to do so will result in damage to frame.

## Optional Trailing Kits

To reduce the width of the frame when narrow areas must be traversed between mowing areas, optional trailing kits with fasteners are available.

Refer to the Parts Catalog for part numbers and order the required parts from your Authorized Toro Distributor.

Use the following illustrations and instructions for positioning and installing the kits.

### Trailing Kit Applications

**5 UNIT REELMASTER UNIVERSAL FRAME TRAILING KITS REQD:**  
2-Trailing Unit Trailing Kits    2-Wing Unit Trailing Kits

MOWING POSITION

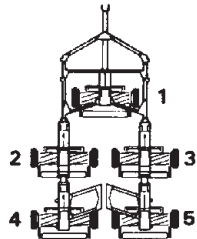
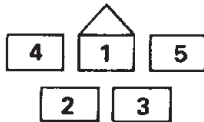

**7 UNIT REELMASTER UNIVERSAL FRAME TRAILING KITS REQD:**  
4-Trailing Unit Trailing Kits    2-Wing Unit Trailing Kits

MOWING POSITION

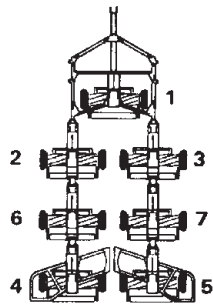
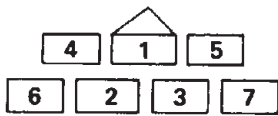

Figure 6

### Installation Of Trailing Kits

1. Locate and drill required mounting holes in trailing units and wing units (Fig. 7 & 8).
2. Install kit parts to trailing unit by mounting trailing bar to rear of frames with hinge pin and (2) cotter pins. Secure snap hook to underside of frame with (2) capscrews and locknuts (Fig. 7).

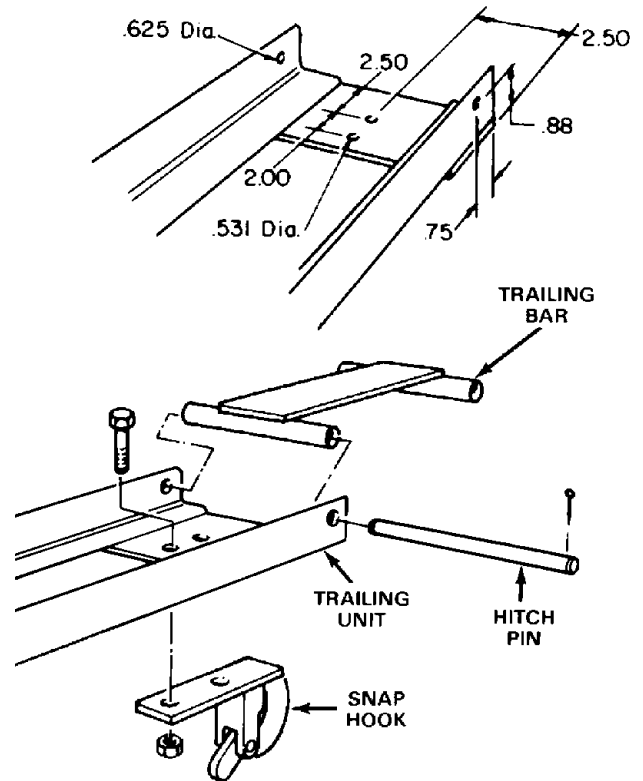

Figure 7

3. Install kit parts to wing unit by securing trailing hitch to underside of frame with (2) capscrews and locknuts (Fig. 8).

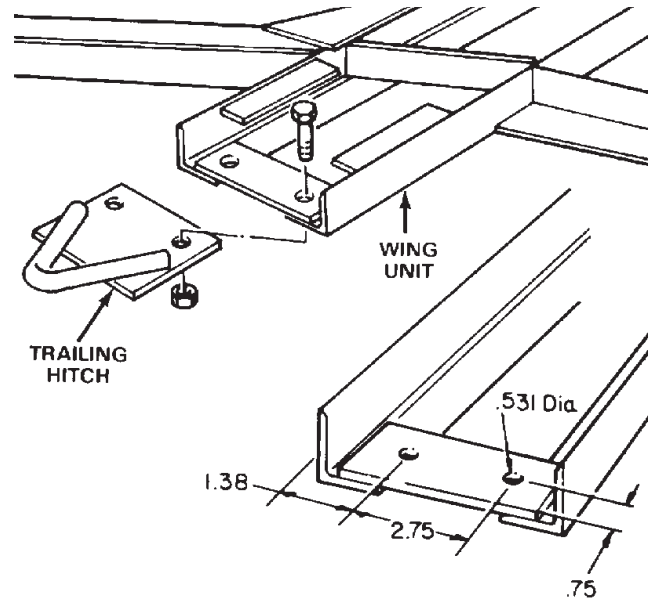

Figure 8

4. Pull entire trailing unit forward and insert bar under two welded plates on frame. Pull unit back snapping the hitch into the snap hook.

# Maintenance

## Lubrication

Every eight hours or daily, whichever occurs first, grease the ball sockets and the drawbars equipped with greaseable pivots with General Purpose No. 2 Lithium Base grease.

1. Wipe each fitting with a clean rag.
2. Apply grease with the gun until clean grease appears around the ball socket openings or around the pivot shafts of the drawbars.
3. Wipe the excess grease away.

## Frame Inspection

Once each week or every 40 hours, check the frame for loose or missing fasteners and broken or damaged frame members. Repair or replace components as necessary.





# The Toro General Commercial Products Warranty

## A Two-Year Limited Warranty

### Conditions and Products Covered

The Toro Company and its affiliate, Toro Warranty Company, pursuant to an agreement between them, jointly warrant your Toro Commercial Product ("Product") to be free from defects in materials or workmanship for two years or 1500 operational hours\*, whichever occurs first. Where a warrantable condition exists, we will repair the Product at no cost to you including diagnosis, labor, parts, and transportation. This warranty begins on the date the Product is delivered to the original retail purchaser.

\* Product equipped with hour meter

### Instructions for Obtaining Warranty Service

You are responsible for notifying the Commercial Products Distributor or Authorized Commercial Products Dealer from whom you purchased the Product as soon as you believe a warrantable condition exists.

If you need help locating a Commercial Products Distributor or Authorized Dealer, or if you have questions regarding your warranty rights or responsibilities, you may contact us at:

Toro Commercial Products Service Department  
Toro Warranty Company  
8111 Lyndale Avenue South  
Bloomington, MN 55420-1196  
952-888-8801 or 800-982-2740  
E-mail: commercial.service@toro.com

### Owner Responsibilities

As the Product owner, you are responsible for required maintenance and adjustments stated in your operator's manual. Failure to perform required maintenance and adjustments can be grounds for disallowing a warranty claim.

### Items and Conditions Not Covered

Not all product failures or malfunctions that occur during the warranty period are defects in materials or workmanship. This express warranty does not cover the following:

- Product failures which result from the use of non-Toro replacement parts, or from installation and use of add-on, modified, or unapproved accessories
- Product failures which result from failure to perform required maintenance and/or adjustments
- Product failures which result from operating the Product in an abusive, negligent or reckless manner
- Parts subject to consumption through use unless found to be defective. Examples of parts which are consumed, or used up, during normal Product operation include, but are not limited to, blades, reels, bedknives, tines, spark plugs, castor wheels, tires, filters, belts, etc.

### Countries Other than the United States or Canada

Customers who have purchased Toro products exported from the United States or Canada should contact their Toro Distributor (Dealer) to obtain guarantee policies for your country, province, or state. If for any reason you are dissatisfied with your Distributor's service or have difficulty obtaining guarantee information, contact the Toro importer. If all other remedies fail, you may contact us at Toro Warranty Company.

- Failures caused by outside influence. Items considered to be outside influence include, but are not limited to, weather, storage practices, contamination, use of unapproved coolants, lubricants, additives, or chemicals, etc.
- Normal "wear and tear" items. Normal "wear and tear" includes, but is not limited to, damage to seats due to wear or abrasion, worn painted surfaces, scratched decals or windows, etc.

### Parts

Parts scheduled for replacement as required maintenance are warranted for the period of time up to the scheduled replacement time for that part.

Parts replaced under this warranty become the property of Toro. Toro will make the final decision whether to repair any existing part or assembly or replace it. Toro may use factory remanufactured parts rather than new parts for some warranty repairs.

### General Conditions

Repair by an Authorized Toro Distributor or Dealer is your sole remedy under this warranty.

**Neither The Toro Company nor Toro Warranty Company is liable for indirect, incidental or consequential damages in connection with the use of the Toro Products covered by this warranty, including any cost or expense of providing substitute equipment or service during reasonable periods of malfunction or non-use pending completion of repairs under this warranty. Except for the Emissions warranty referenced below, if applicable, there is no other express warranty. All implied warranties of merchantability and fitness for use are limited to the duration of this express warranty.**

Some states do not allow exclusions of incidental or consequential damages, or limitations on how long an implied warranty lasts, so the above exclusions and limitations may not apply to you.

This warranty gives you specific legal rights, and you may also have other rights which vary from state to state.

**Note regarding engine warranty:** The Emissions Control System on your Product may be covered by a separate warranty meeting requirements established by the U.S. Environmental Protection Agency (EPA) and/or the California Air Resources Board (CARB). The hour limitations set forth above do not apply to the Emissions Control System Warranty. Refer to the Engine Emission Control Warranty Statement printed in your operator's manual or contained in the engine manufacturer's documentation for details.