



Maintaining the Primary Drive Clutch for Workman[®] 1100, 2100, and 2110 Vehicles and Multi-Pro[®] 1200 and 1250 Turf Sprayers

Model No. 07252—Serial No. 210000001 and Up
 Model No. 07252TC—Serial No. 210000001 and Up
 Model No. 07253—Serial No. 200000001 and Up
 Model No. 07253TC—Serial No. 200000001 and Up
 Model No. 07277—Serial No. 220000001 and Up
 Model No. 07277TC—Serial No. 220000001 and Up
 Model No. 41106—Serial No. 200000001 and Up
 Model No. 41107—Serial No. 200000001 and Up

Operator's Manual Addendum

Important Place this addendum with your *Operator's Manual* for future reference.

After every 400 operating hours or yearly, clean and lubricate the clutch as follows:

1. If you have a Workman vehicle, raise and latch the cargo box.
2. Stop the engine, remove the key, and set the parking brake.
3. If you have a Multi-Pro turf sprayer, complete the following:
 - A. Raise the front end of the sprayer and support it on jack stands.

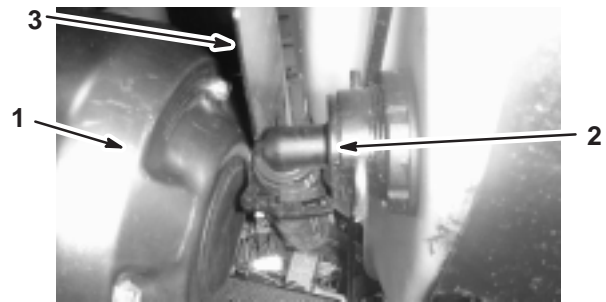

Figure 1

- | | |
|-----------------|----------------|
| 1. Clutch cover | 3. Heat shield |
| 2. Hose | |



Danger



A sprayer on a jack may be unstable and slip off of the jack, injuring anyone beneath it.

- Do not start the engine while the sprayer is on a jack.
- Always remove the key from the ignition before getting off of the sprayer.
- Block the tires when the sprayer is on a jack.

- B. Disconnect the hose located on the lower-front face of the tank (Fig. 1).

- Remove the 3 bolts securing the cover to the clutch and remove the cover (Fig. 2).

Note: On a sprayer, you may need to push the heat shield (Fig. 1) back as you remove the cover.

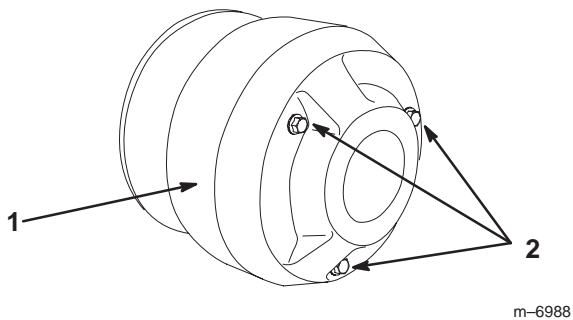



Figure 2

- Cover
- Bolts

- Thoroughly clean the inside of the cover and the inner workings of the clutch using compressed air.

	Caution	
<p>The dust in the clutch will become airborne and could damage your eyes or you could inhale it causing breathing difficulties.</p> <p>Wear safety goggles and a dust mask or other eye and respiratory protection when performing this procedure.</p>		

Recommended Maintenance Schedule

Add the following line to the Recommended Maintenance Schedule in your *Operator's Manual*:

Every 400 hours or yearly	<ul style="list-style-type: none"> Clean and lubricate the primary drive clutch
---------------------------	--

- Lubricate the moving parts in the areas circled in Figure 3 using Toro Dry Lubricant Spray, available through your Authorized Toro Dealer or Distributor.

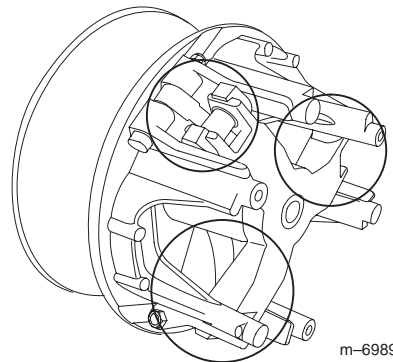

Figure 3

- Install the clutch cover and secure it with the 3 bolts removed previously.
- On a sprayer, connect the hose on the front of the tank (Fig. 1).