



72" Cutting Unit

Groundsmaster[®] 300 Series

Model No. 30722—Serial No. 240000001 and Up

Model No. 30722TE—Serial No. 240000001 and Up

Model No. 30710—Serial No. 240000001 and Up

Model No. 30710TE—Serial No. 240000001 and Up

Operator's Manual



Contents

	Page
Contents	2
Introduction	2
Safety	3
Safe Operating Practices	3
Toro Mower Safety	4
Safety and Instruction Decals	5
Specifications	7
General Specifications	7
Optional Equipment	7
Setup	8
Installing the Castor Wheel Assemblies	9
Grass Deflector (Model 30722 & 30722TE)	9
Installing Belly Shield (Model 30710 & 30710TE)	10
Installing the Ball Joint and Connecting the Lift Cylinder	10
Connecting the PTO Shaft to the Traction Unit ...	11
Connecting the Right-Hand Push Arm to the Cutting Unit	11
Connecting Left-Hand Push Arm to Cutting Unit .	12
Connecting PTO Shaft and Installing Lift Chains .	13
Greasing the Cutting Unit	13
Installing Rear Weight	13
Before Operating	14
Checking the Lubricant in the Gear Box	14
Operation	14
Adjusting the Height-of-Cut	14
Using the Grass Deflector	15
Maintenance	16
Recommended Maintenance Schedule	16
Greasing the Bearings, Bushings, and Gear Box ..	16
Separating the Cutting Unit from the Traction Unit	17
Mounting the Cutting Unit to the Traction Unit ..	18
Replacing the Blade Drive Belts	19
Servicing the Bushings in the Castor Arms	19
Servicing the Rear Castor Wheel and Bearing	19
Servicing the Front Wheel Castor Bearing	20
Removing the Cutting Blade	21
Inspecting and Sharpening the Blade	21
Checking and Correcting Mismatch of Blades ...	22
Troubleshooting	23
The Toro General Commercial Products Warranty ...	24

Introduction

Read this manual carefully to learn how to operate and maintain your product properly. The information in this manual can help you and others avoid injury and product damage. Although Toro designs and produces safe products, you are responsible for operating the product properly and safely.

Whenever you need service, genuine Toro parts, or additional information, contact an Authorized Service Dealer or Toro Customer Service and have the model and serial numbers of your product ready. Figure 1 illustrates the location of the model and serial numbers on the product (just ahead of the left rear castor wheel).

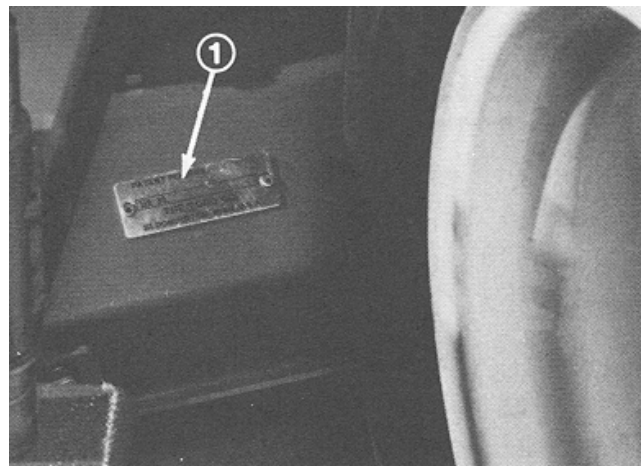

Figure 1

1. Location of the model and serial numbers

Write the product model and serial numbers in the space below:

Model No. _____
Serial No. _____

This manual identifies potential hazards and has special safety messages that help you and others avoid personal injury and even death. **Danger**, **Warning**, and **Caution** are signal words used to identify the level of hazard. However, regardless of the hazard, be extremely careful.

Danger signals an extreme hazard that *will* cause serious injury or death if you do not follow the recommended precautions.

Warning signals a hazard that *may* cause serious injury or death if you do not follow the recommended precautions.

Caution signals a hazard that may cause minor or moderate injury if you do not follow the recommended precautions.

This manual uses two other words to highlight information. **Important** calls attention to special mechanical information and **Note**: emphasizes general information worthy of special attention.

Safety

This machine meets or exceeds CEN standard EN 836:1997, ISO standard 5395:1990, and ANSI B71.4-1999 specifications in effect at the time of production.

Improper use or maintenance by the operator or owner can result in injury. To reduce the potential for injury, comply with these safety instructions and always pay attention to the safety alert  symbol, which means CAUTION, WARNING, or DANGER—“personal safety instruction.” Failure to comply with the instruction may result in personal injury or death.

Safe Operating Practices

The following instructions are from the CEN standard EN 836:1997, ISO standard 5395:1990, and ANSI B71.4-1999.

Training

- Read the Operator’s Manual and other training material. If the operator(s) or mechanic(s) can not read English it is the owner’s responsibility to explain this material to them.
- Become familiar with the safe operation of the equipment, operator controls, and safety signs.
- All operators and mechanics should be trained. The owner is responsible for training the users.
- Never let children or untrained people operate or service the equipment. Local regulations may restrict the age of the operator.
- The owner/user can prevent and is responsible for accidents or injuries occurring to himself or herself, other people or property.

Preparation

- Evaluate the terrain to determine what accessories and attachments are needed to properly and safely perform the job. Only use accessories and attachments approved by the manufacturer.
- Wear appropriate clothing including hard hat, safety glasses and ear protection. Long hair, loose clothing or jewelry may get tangled in moving parts.
- Inspect the area where the equipment is to be used and remove all objects such as rocks, toys and wire which can be thrown by the machine.

- Use extra care when handling gasoline and other fuels. They are flammable and vapors are explosive.
 - Use only an approved container.
 - Never remove fuel cap or add fuel with engine running. Allow engine to cool before refueling. Do not smoke.
 - Never refuel or drain the machine indoors.
- Check that operator’s presence controls, safety switches and shields are attached and functioning properly. Do not operate unless they are functioning properly.

Operation

- Never run an engine in an enclosed area.
- Only operate in good light, keeping away from holes and hidden hazards.
- Be sure all drives are in neutral and parking brake is engaged before starting engine. Only start engine from the operator’s position. Use seat belts if provided.
- Slow down and use extra care on hillsides. Be sure to travel in the recommended direction on hillsides. Turf conditions can affect the machine’s stability. Use caution while operating near drop-offs.
- Slow down and use caution when making turns and when changing directions on slopes.
- Never raise deck with the blades running.
- Never operate with guards not securely in place. Be sure all interlocks are attached, adjusted properly, and functioning properly.
- Do not change the engine governor setting or overspeed the engine.
- Stop on level ground, lower the cutting units, disengage drives, engage parking brake (if provided), shut off engine before leaving the operator’s position for any reason.
- Stop equipment and inspect the blades after striking objects or if an abnormal vibration occurs. Make necessary repairs before resuming operations.
- Keep hands and feet away from the cutting units.
- Look behind and down before backing up to be sure of a clear path.
- Never carry passengers and keep pets and bystanders away.
- Slow down and use caution when making turns and crossing roads and sidewalks. Stop blades if not mowing.
- Do not operate the mower under the influence of alcohol or drugs.

- Use care when loading or unloading the machine into a trailer or truck.
- Use care when approaching blind corners, shrubs, trees, or other objects that may obscure vision.
- The operator shall turn on flashing warning lights, if provided, whenever traveling on a public road, except where such use is prohibited by law.

Maintenance and Storage

- Disengage drives, lower the cutting units, move traction pedal to Neutral, set parking brake, stop engine and remove key and disconnect spark plug wire. Wait for all movement to stop before adjusting, cleaning or repairing.
- Clean grass and debris from cutting units, drives, mufflers, and engine to help prevent fires. Clean up oil or fuel spillage.
- Let engine cool before storing and do not store near flame.
- Shut off fuel while storing or transporting. Do not store fuel near flames or drain indoors.
- Park machine on level ground. Never allow untrained personnel to service machine.
- Use jack stands to support components when required.
- Carefully release pressure from components with stored energy.
- Disconnect battery or remove spark plug wire before making any repairs. Disconnect the negative terminal first and the positive last. Reconnect positive first and negative last.
- Use care when checking blades. Wrap the blades or wear gloves, and use caution when servicing them. Only replace blades. Never straighten or weld them.
- Keep hands and feet away from moving parts. If possible, do not make adjustments with the engine running.
- Charge batteries in an open well ventilated area, away from spark and flames. Unplug charger before connecting or disconnecting from battery. Wear protective clothing and use insulated tools.
- Keep all parts in good working condition and all hardware tightened. Replace all worn or damaged decals.

Toro Mower Safety

The following list contains safety information specific to Toro products or other safety information that you must know that is not included in the ANSI standards.

This product is capable of amputating hands and feet and throwing objects. Always follow all safety instructions to avoid serious injury or death.

Use of this product for purposes other than its intended use could prove dangerous to user and bystanders.

Operation

- Know how to stop the machine and engine quickly.
- Always wear substantial shoes. Do not operate the machine while wearing sandals, tennis shoes, or sneakers.
- Wearing safety shoes and long pants is advisable and required by some local ordinances and insurance regulations.
- Fill fuel tank until level is 1 in. (25 mm) below the bottom of the filler neck. Do not overfill.
- Check the safety interlock switches daily for proper operation. If a switch should fail, replace the switch before operating the machine. After every two years, replace all three interlock switches in the safety system, **regardless** if they are working properly or not.
- Pay attention when using the machine. To prevent loss of control:
 - Do not drive close to sand traps, ditches, creeks, or other hazards.
 - Avoid sudden stops and starts.
 - Watch for traffic when near or crossing roads. Always yield the right-of-way.
 - Lower the cutting unit when going down slopes.
- The grass deflector must always be installed and in the lowest position on the side discharge cutting unit. Never operate the mower without the deflector or entire grass collector.
- If the cutting unit discharge area ever plugs, shut the engine off before removing the obstruction.
- Cut grass slopes carefully. Do not start, stop, or turn suddenly.
- Do not touch the engine or muffler while the engine is running or soon after it has stopped because these areas could be hot enough to cause burns.

Maintenance and Storage

- Check the blade mounting bolts frequently to be sure that they are tightened to specification.
- Make sure that all hydraulic line connectors are tight and all hydraulic hoses and lines are in good condition before applying pressure to the system.

- Keep your body and hands away from pin hole leaks or nozzles that eject hydraulic fluid under high pressure. Use paper or cardboard, not your hands, to search for leaks. Hydraulic fluid escaping under pressure can have sufficient force to penetrate the skin and cause serious injury.
- Before disconnecting or performing any work on the hydraulic system, all pressure in the system must be relieved by stopping the engine and lowering the cutting units to the ground.
- If the engine must be running to perform a maintenance adjustment, keep hands, feet, clothing, and any parts of the body away from the cutting units, attachments, and any moving parts. Keep everyone away.
- Do not overspeed the engine by changing governor settings. To ensure safety and accuracy, have an Authorized Toro Distributor check the maximum engine speed with a tachometer.
- The engine must be shut off before checking the oil or adding oil to the crankcase.
- Make sure that the mower fuel tank is empty if the machine is to be stored in excess of 30 days. Do not store the mower near any open flame or where gasoline fumes may be ignited by a spark.
- Perform only those maintenance instructions described in this manual. If major repairs are ever needed or if assistance is desired, contact an Authorized Toro Distributor.
- To make sure of optimum performance and continued safety certification of the machine, use only genuine Toro replacement parts and accessories. Replacement parts and accessories made by other manufacturers could be dangerous, and such use could void the product warranty.

Safety and Instruction Decals



Safety decals and instructions are easily visible to the operator and are located near any area of potential danger. Replace any decal that is damaged or lost.

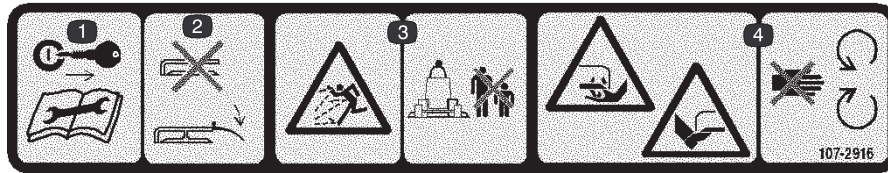

107-2916 (Model 30722 and 30722TE only)

1. Remove the ignition key and read the instructions before servicing or performing maintenance.
2. Do not operate the mower with the deflector up or removed; keep the deflector in place.
3. Thrown object hazard—keep bystanders a safe distance from the machine.
4. Cutting/dismemberment hazard of hand or foot, mower blade—stay away from moving parts

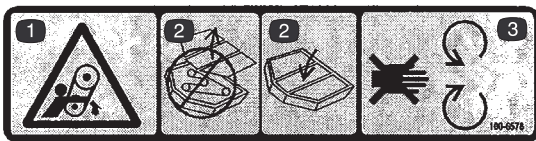

100-6578

1. Warning—hand and arm entanglement.
2. Keep the deck covers in place.
3. Stay away from moving parts.



93-7817

1. Warning—read the operator's manual for further information on torquing the blade bolt.

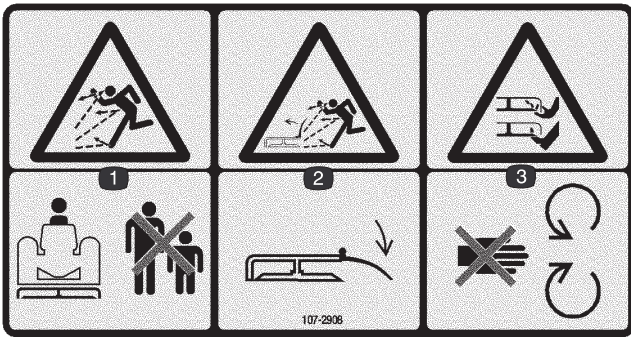

107-2908

1. Thrown object hazard—keep bystanders a safe distance from the machine.
2. Thrown object hazard, mower—keep the deflector in place.
3. Cutting/dismemberment hazard of hand or foot, mower blade—stay away from moving parts.



43-8480 (Model 30722 only)



93-6697

1. Read the operator's manual for further information on lubrication.

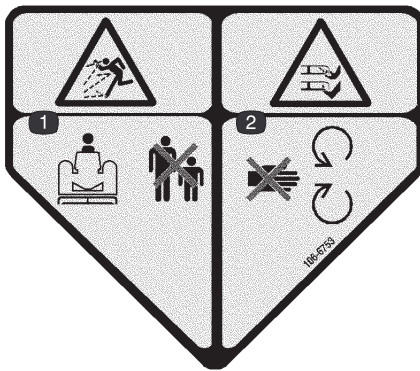

106-6753

1. Thrown object hazard—keep bystanders a safe distance from the machine.
2. Cutting/dismemberment hazard of hand or foot, mower blade—stay away from moving parts.



107-2915 (Model 30722TE and 30710TE only)

1. Entanglement hazard, shaft—keep bystanders a safe distance from the machine.

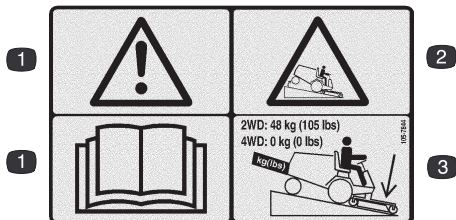

105-7844

1. Warning—read the operator's manual.
2. Lower cutting unit when going down slopes.
3. Groundsmaster 328-D or Groundsmaster 345 2 wheel drive units need 48 kg (105 lb.) of rear weight. Four-wheel drive units do not need any rear weight.

Specifications

General Specifications

Width of Cut	Models 30722 and 30710 have a 71-1/2 inch (1.816 m) width of cut.
Height-of-Cut	Adjustable from 1 to 4 in. (25 to 102 mm) in 1/2 in. (13 mm) increments
Cutter Housing	Both cutter housings are made from 11 gauge (13 mm) steel and reinforced with 3-1/2 inch (89 mm) x 7 gauge (4.76 mm) channel iron.
Cutting Unit Drive	Gear box mounted on cutting unit is driven by PTO shaft. Power is transmitted to the blades by three B section belts. Spindle shafts are 1-1/4 inch (32 mm) in diameter and supported by two externally sealed, greaseable, tapered roller bearings.
Cutting Unit	Front mounted cutting units have front and rear caster wheels, three heat-treated steel blades 25 inches (0.63 m) long and 1/4 inch (6 mm) thick.
Castor Wheels	Two front castor wheels have roller bearings with 10.25 in. (260 mm) x 3.25 in. (83 mm) hard rubber tires. Rear wheels have roller bearings and 6 in. (153 mm) x 2.50 in. (64 mm) hard rubber tires.
Blade Tip Speed	At 3200 engine rpm, blade tip speed is 15,000 ft/min. (76.2 m/sec.).
Cutting Unit Lift	Cutting units are lifted by hydraulic cylinder that has a 2-1/2 in. (64 mm) bore and 3-1/4 in. (82 mm) stroke.
Width	Model 30722 & 30722TE: 85-1/2 in. (2.17 m) Model 30710 & 30710TE: 76 in. (1.93 m)
Weight	Model 30722 & 30722TE: 400 lb. (181.4 kg) Model 30710 & 30710TE: 415 lb. (188.2 kg)

Optional Equipment

High Sail Blade	Part No. 23-2410
23 x 10.5 x 12 Tire and Wheel (Model 30722 only)	Part No. 36-1050
Blade and Belt Kit	Part No. 95-3087
Blade and Belt Kit (Hi-Lift)	Part No. 95-3094
Front Castor Wheel	Part No. 95-3082
Rear Castor Wheel	Part No. 95-3084
Left-Hand Spindle Assembly	Part No. 95-3089
Center Spindle Assembly	Part No. 95-3090
Right-Hand Spindle Assembly	Part No. 95-3095
Leaf Mulcher Kit	Model No. 30733
Quick Attach Kit	Model No. 30719
Atomic Blade	Part No. 106-4354
Front Castor Wheel (Foam Filled)	Part No. 93-5973

Setup

Note: Determine the left and right sides of the machine from the normal operating position.

Note: Use this chart as a checklist to ensure that all parts necessary for assembly have been shipped. Without any of these parts, total setup cannot be completed.

Description	Qty.	Use
Large castor wheel assembly	2	Installing the castor wheel assembly
Small castor wheel assembly	2	
Belly shield	1	Installing the belly shield (Model 30710 only)
Belly shield hook	2	
Locknut, 5/16 in.	4	
Belly shield hanger	2	
Capscrew, 3/8 x 1-1/4 in.	2	
Nut	2	
Hairpin cotter	2	
Clevis pin, 3/8 x 1-7/8 in.	2	
Belly shield spacer (Diesel only)	2	
Capscrew, 7/16 x 3 in.	2	Connecting the right-hand push arm to the cutting unit
Flat washer, 7/16 in.	2	
Nut, 7/16 in.	2	
Flat washer, 7/16 in.	2	Connecting the left-hand push arm to the cutting unit
Capscrew, 7/16 x 3 in.	2	
Nut, 7/16 in.	2	
PTO shaft	1	Connecting the PTO shaft
Capscrew, 5/16 x 1-3/4 in.	2	
Locknut, 5/16 in.	2	
Roll pin, 3/16 x 1-1/2 in.	2	
Declaration of Conformity	1	Model 30722 & 30710 TE only
EEC 105 decal	1	
Parts Catalog	1	
Operator's manual	1	Read before operating the machine.

Installing the Castor Wheel Assemblies

The thrust washers, spacers, and tensioning caps have been installed on the castor wheel spindles for shipping.

1. Remove the tensioning caps from the spindle shafts and slide off the spacers and thrust washers (Fig. 2 and 3).

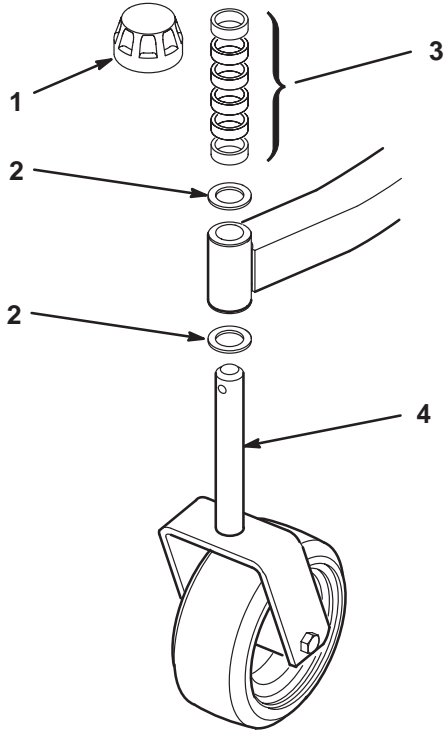

Figure 2

- | | |
|-------------------|-------------------------|
| 1. Tensioning cap | 3. Spacers |
| 2. Thrust washers | 4. Front castor spindle |

2. Slide the spacers onto the castor spindle to get the desired height-of-cut; refer to the Height-of-Cut Chart, page 14. Slide a thrust washer onto the spindle, push the round castor spindle through the front castor arm and the hexagon castor spindle through the rear castor arm. Install another thrust washer and the remaining spacers onto the spindle and install the tensioning cap to secure the assembly.

Important The thrust washers, not the spacers, must contact the top and bottom of the castor arm.

3. Ensure that all four castor wheels are set at the same height-of-cut and roll the cutting unit off of the pallet.

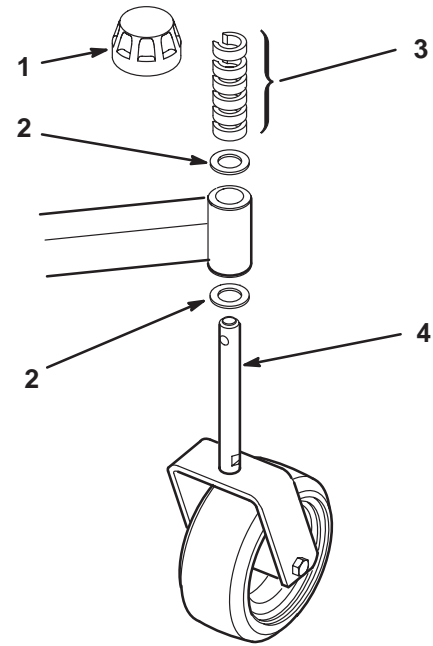

Figure 3

- | | |
|-------------------|------------------------|
| 1. Tensioning cap | 3. Spacers |
| 2. Thrust washers | 4. Rear castor spindle |

Grass Deflector (Model 30722 & 30722TE)

Remove the shipping bands allowing the deflector to be lowered (Fig. 4).

⚠
Warning
⚠

The deflector is spring loaded in the down position and will rotate downward when the band is cut. If done improperly, it may cause personal injury.

Restrain the deflector when cutting the band.

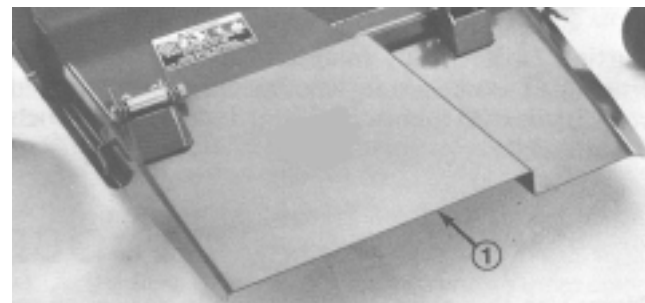

Figure 4

1. Deflector—lowest position

Installing the Belly Shield (Model 30710 & 30710TE)

1. Position the traction unit on level surface, shut the engine off, and engage the parking brake.
2. Block up the forward end of the engine to prevent it from shifting during disassembly.
3. Remove the capscrew and flange nut securing the front engine support to the frame. Secure the belly shield hanger and engine support to the frame with a capscrew (3/8 x 1-1/4 in.) and flange nut. Repeat the procedure on the opposite side of the machine (Fig. 5). Discard the capscrew (3/8 x 1 in.) removed (gas units only).

Note: On diesel units, a 3/8 in. thick spacer must be inserted between the shield hanger and frame.

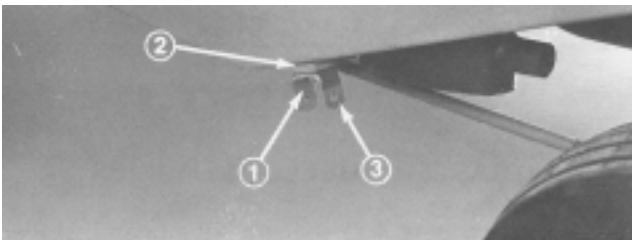

Figure 5

1. Capscrew and flange nut
2. Engine support or spacer (diesel only)
3. Shield hanger

4. Position the belly shield mounting hooks over the hub of the push arm mounting brackets (Fig. 6).

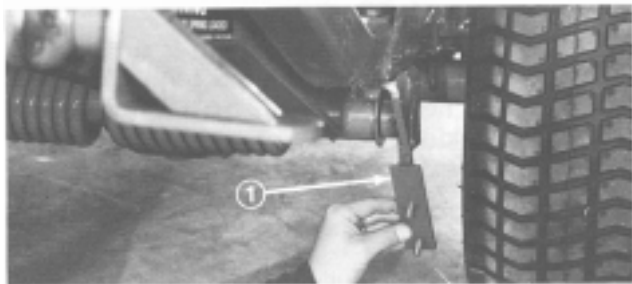

Figure 6

1. Belly shield mounting hooks

5. Secure the belly shield to the belly shield hooks with 2 locknuts (5/16 in.) on each side (Fig. 7).

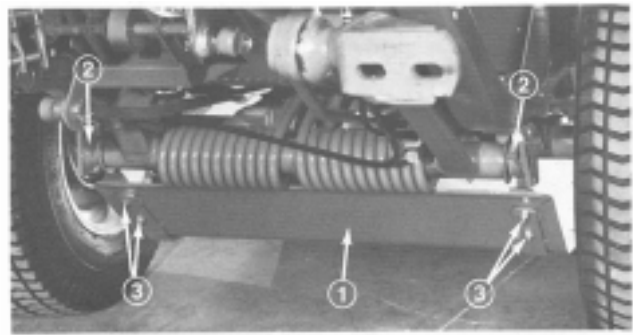

Figure 7

1. Belly shield
2. Belly shield hook
3. Locknuts

6. Raise the rear of the belly shield and secure it to the belly shield hangers with a clevis pin and hairpin cotter on each side (Fig. 8). Push the hairpin cotter all the way to the loop, to prevent loss.

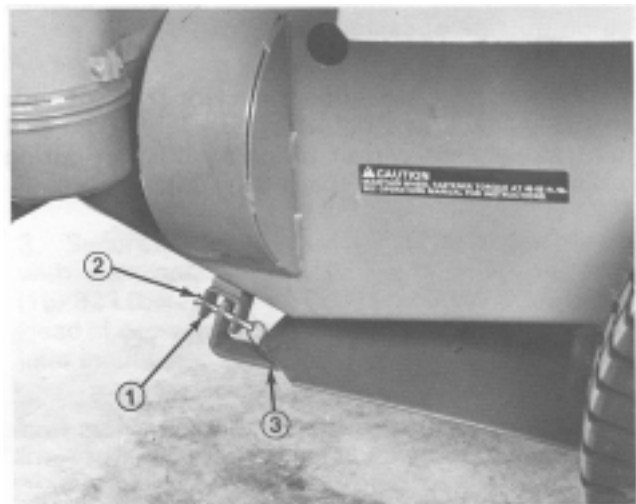

Figure 8

1. Belly shield hanger
2. Clevis pin
3. Hairpin cotter

Installing the Ball Joint and Connecting the Lift Cylinder

Note: The ball joints are shipped with the traction units.

1. Thread the jam nut fully onto the right-hand ball joint.
2. Screw the ball joint into the right-hand push arm until the center of the ball joint is 2-3/8 inches (60 mm) away from the front of the push arm (Fig. 9). Do not tighten the jam nut.



Warning



Push arms are spring loaded. Sudden release of the push arms could cause injury.

Another person is required to push the arms down during installation of the ball joints or other implements.

3. Have another person push down on the left push arm. Insert a 2 x 4 in. (51 x 102 mm) block of wood between the frame and the top of the push arm (Fig. 9). Screw the ball joint into the left-hand push arm until the center of the ball joint is 2-3/8 inches (60 mm) away from the front of the push arm (Fig. 10). Do not tighten the jam nut.

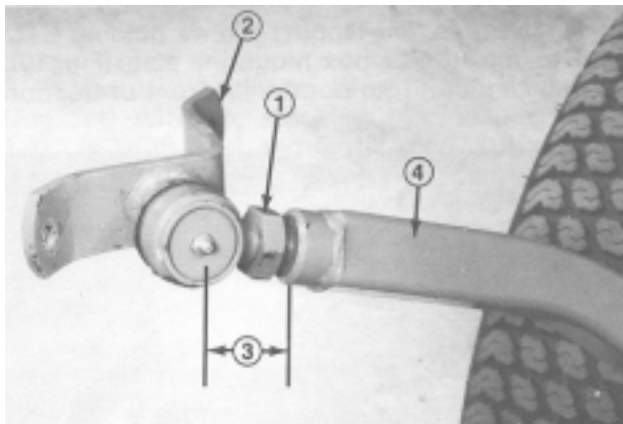

Figure 9

- | | |
|---------------------|------------------------|
| 1. Jam nut | 3. 2-3/8 in. (60 mm) |
| 2. Ball joint mount | 4. Right-hand push arm |

4. Carefully remove the 2 x 4 in. (51 x 102 mm) block of wood from between the frame and push arm.
5. Remove the spring pin from the cylinder pin and slide the cylinder pin out of the cylinder.
6. Raise the front of the lift arm until the hole in the movable end of the cylinder lines up with the holes in the lift arm brackets. Use caution as the lift arm is spring-loaded. Hold the parts together with the cylinder pin, spring pin, and cotter pin. The cotter pin must be to the outside.

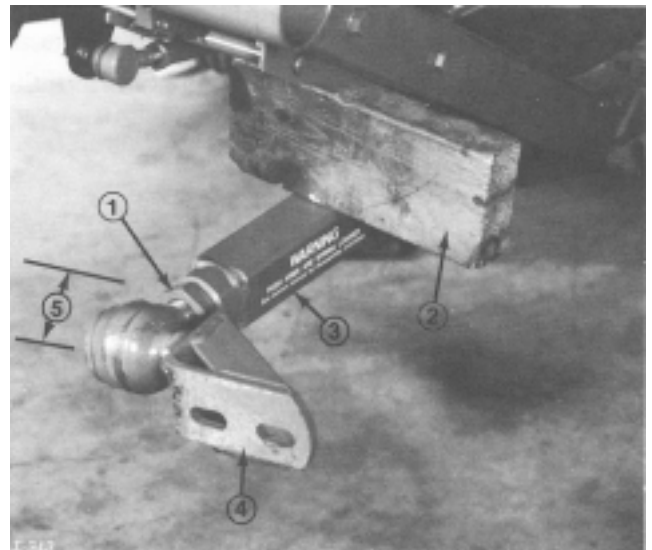

Figure 10

- | | |
|----------------------------------|-----------------------|
| 1. Jam nut | 3. Left-hand push arm |
| 2. 2 x 4 in. (51 x 102 mm) block | 4. Ball joint mount |
| | 5. 2-3/8 in. (60 mm) |

Connecting the PTO Shaft to the Traction Unit

Slide the smaller yoke end of the PTO shaft onto the traction unit PTO shaft while aligning the mounting holes (Fig. 14). Secure it with a roll pin. Do not install the front end of the drive shaft at this time.

Connecting the Right-Hand Push Arm to the Cutting Unit

1. Remove the bands securing the PTO shaft to the underside of the traction unit.
2. Remove the 2 self-tapping screws holding the PTO shield to the top of the gear box mounting plate (Fig. 11). Move the cutting unit into position in front of the traction unit.

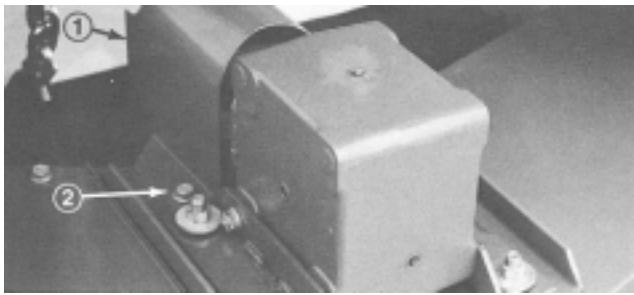

Figure 11

1. PTO shield
2. Self-tapping screw (2)



Warning



The right-hand push arm is spring-loaded to about 100 lb. (445 N). Sudden release of the push arm could result in injury.

Another person is needed to push the arm down.

3. Have another person carefully push down on the push arm until the holes in the ball joint mount line up with the holes in the castor arm.
4. Secure the ball joint mount to the castor arm (Fig. 12) with 2 capscrews (7/16 x 3 in.), flat washer (7/16 in.), and nuts (7/16 in.). The head of the capscrew and the large flat washer must be outside of the castor arm.
5. Tighten the large jam nut against the front of the right push arm (Fig. 12). When tightening the jam nut, hold the ball joint straight to permit proper oscillation during raising and lowering of the cutting unit.

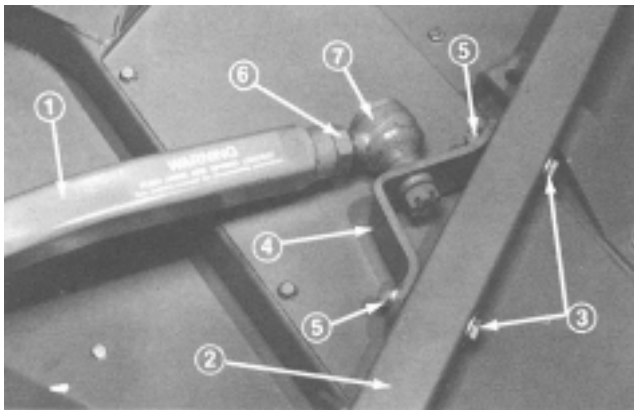

Figure 12

1. Right-hand push arm
2. Castor arm
3. capscrews and flat washers
4. Ball joint mount
5. Flange locknuts
6. Jam nut
7. Ball joint

Connecting the Left-Hand Push Arm to the Cutting Unit

1. Remove the capscrews, nuts, and flat washers from the push arm mount holes in the left castor arm.



Warning



The left-hand push arm is spring-loaded to about 150 lb. (667 N). Sudden release of the push arm could result in injury.

Another person is needed to push the arm down.

2. Have another person carefully push down on the push arm until the ball joint mount contacts the front of the mount bracket on the cutting unit. Immediately slide a 4 x 4 in. (102 x 102 mm) block of wood between the top of the push arm and the underside of the chassis.



Warning



Make sure that the wooden block does not accidentally slip out.

Note: If the holes in the ball joint mount do not line up with the holes in the mount bracket, turn the ball joint until correct alignment results.

3. Secure the ball joint mount (Fig. 13) to the mount bracket with 2 capscrews (7/16 x 3 in.), flat washer (7/16 in.), and nuts (7/16 in.). The head of the capscrews and flat washer must contact the ball joint mount.
4. Tighten the large jam nut against the front of the left push arm (Fig. 13). When tightening the jam nut, hold the ball joint straight to permit proper oscillation during raising and lowering of the cutting unit.
5. Carefully remove the block holding the push arm down.

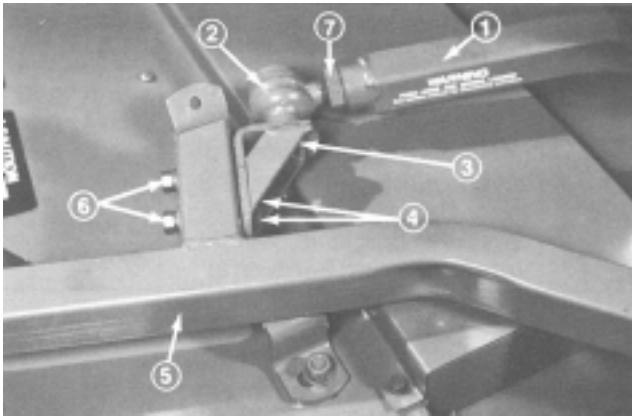

Figure 13

- | | |
|-------------------------------|--------------------|
| 1. Left-hand push arm | 5. Castor arm |
| 2. Ball joint | 6. Flange locknuts |
| 3. Ball joint mount | 7. Jam nuts |
| 4. Capscrews and flat washers | |

Connecting the PTO Shaft and Installing the Lift Chains

Important The PTO shaft yokes must be exactly in line with each other when the outer PTO sleeve is installed on the splined shaft. Remove the sleeve and change the yoke position if the alignment is not correct. Misalignment of the two yokes will shorten the life of the PTO shaft assembly and cause unnecessary vibration when the cutting unit is operated.

1. Line up the holes in the yoke and input shaft of the gear box. Slide the yoke onto the shaft (Fig. 14) and secure the parts together with a roll pin (3/16 x 1-1/2 in.). Tighten the 2 capscrews and locknuts securing the yoke to the input shaft.

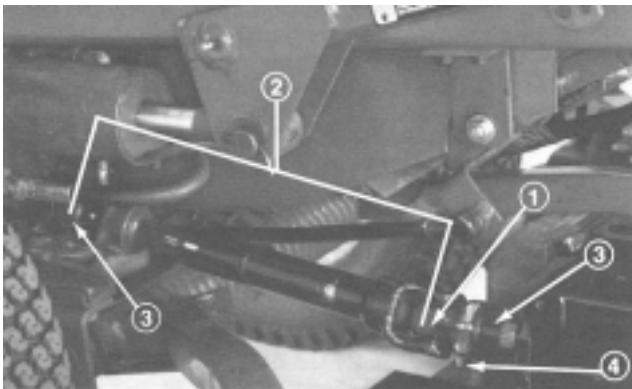

Figure 14

- | | |
|-------------------|---------------------------|
| 1. PTO yoke | 3. Roll pin |
| 2. Yokes in phase | 4. Capscrews and locknuts |

2. Mount the PTO shield over the input shaft and onto the gear box mounting plate with two self-tapping screws (Fig. 15).
3. Attach the lift chains to the lift arm and cutting unit (Fig. 15) with 6 shackles, shackle pins (3/8 x 1-1/2 in.), and cotter pins (1/8 x 3/4 in.). Adjust the chain length so that both become tight at the same time when lifting the lift arm.
4. Connect the ends of the tension spring between the fourth link of the rear chain and the eye of the cotter pin that holds the cylinder pin in place (Fig. 15). Adjust the length of the chain so that the rear caster wheels are off of the ground in the transport position.

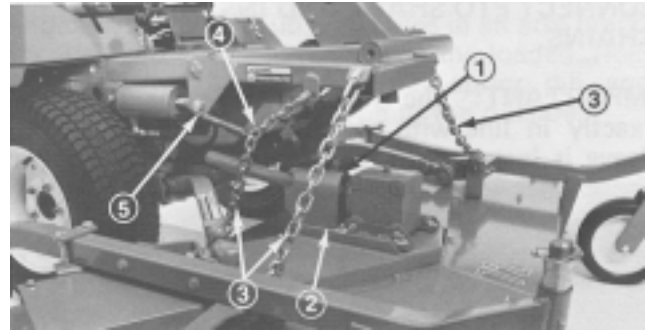

Figure 15

- | | |
|------------------------|--------------------------|
| 1. PTO shield | 4. Spring in fourth link |
| 2. Self-tapping screws | 5. Spring in cotter pin |
| 3. Lift chain | |

Greasing the Cutting Unit

Before the cutting unit is operated, it must be greased to ensure proper lubricating characteristics; refer to Greasing the Bearings, Bushings, and Gear Box, page 16. Failure to grease the machine will result in premature failure of critical parts.

Installing Rear Weight

Two Wheel Drive Groundsmaster 300 Series traction units comply with the ANSI B71.4-1999 Standard when equipped with rear weight. Refer to the chart in the traction unit Operator's Manual to determine the combinations of weight required. Order the parts from your local Authorized Toro Distributor.

Four Wheel Drive Groundsmaster 300 Series traction units do not need additional rear weight to comply with the ANSI B71.4-1999 Standard.

Before Operating

Checking the Lubricant in the Gear Box

The gear box is designed to operate on SAE 80–90 wt. gear lube. Although the gear box is shipped with lubricant from the factory, check the level before operating the cutting unit.

1. Position the machine and cutting unit on a level surface.
2. Remove the dipstick/fill plug from the top of the gear box (Fig. 16) and make sure that the lubricant is between the marks on the dipstick. If the lubricant level is low, add enough lubricant until the level is between the marks.

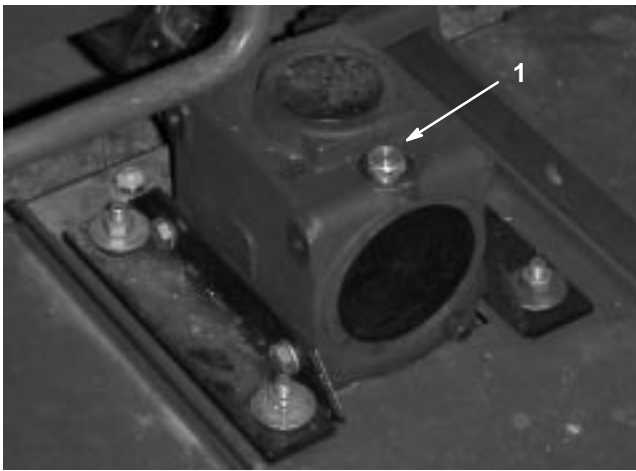

Figure 16

1. Dipstick/fill plug

Operation

Note: Determine the left and right sides of the machine from the normal operating position.

The use of protective equipment, such as but not limited to, for eyes, ears, feet, and head is recommended.

! **Caution** !

This machine produces sound levels in excess of 85 dBA at the operator's ear and can cause hearing loss through extended periods of exposure.

Wear hearing protection when operating this machine.

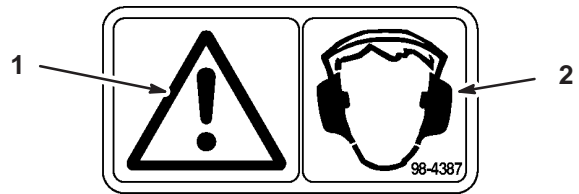

Figure 17

1. Caution
2. Wear hearing protection

Adjusting the Height-of-Cut

The height-of-cut is adjustable from 1 to 4 inches (25 to 102 mm) in 1/2 inch (13 mm) increments, by adding or removing an equal number of spacers on the front and rear castor forks. The height-of-cut chart below gives the combinations of spacers to use for all height-of-cut settings.

Note: 1/4 inch (6 mm) spacers are available and can be ordered from your Toro distributor by Part No. 27-1040. (Quantity of 8).

Height-of-Cut Setting (inches)	Spacers Below Castor Arm	
	Front	Rear
1 (25 mm)	0	0
1-1/2 (38 mm)	1	1
2 (51 mm)	2	2
2-1/2 (64 mm)	3	3
3 (76 mm)	4	4
3-1/2 (89 mm)	5	5
4 (102 mm)	6	6

Note: A more optimum cutting appearance of the turf can be achieved in the lower heights-of-cut by lowering the rear of the cutting unit. Accomplish this by relocating the rear castor wheel axles in the upper hole of the caster forks (Fig. 19). Place the axles into the lower castor fork holes for higher height-of-cut settings where optimum cutting appearance is not required.

Important Do not attempt to cut off more than 1 inch (25 mm) of the grass blades in the 1 inch (25 mm) height-of-cut setting with the rear of the cutting unit lowered, as this may cause the engine to labor excessively.

1. Start the engine and raise the cutting unit so that the front caster height-of-cut can be changed. Stop the engine after the cutting unit is raised. The rear castor height-of-cut can be changed with the cutting unit lowered.
2. Remove the tensioning cap from the spindle shaft. Slide the spacers onto the castor spindle to get the desired height-of-cut (Fig. 18 and 19). Then slide the washer (Fig. 18 and 19) onto the spindle.
3. Push the castor spindle through the castor arm. Slide any remaining spacers onto the spindle (Fig. 18 and 19). Install the tensioning cap to secure the assembly.

Note: When the cutting unit is used in the 1 in. (25 mm) or 1-1/2 in. (38 mm) height-of-cut setting, the front and rear rollers must be positioned in the upper bracket holes.

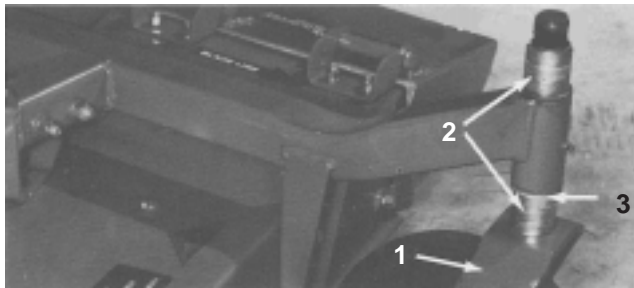

Figure 18

1. Large (front) castor
2. Spacers
3. Washer

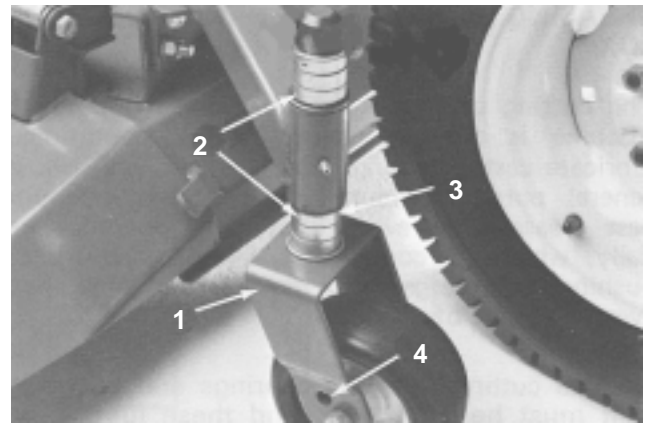

Figure 19

1. Small (rear) castor
2. Spacers
3. Washer
4. For 1 in. (25 mm) height-of-cut only

Using the Grass Deflector



Danger



Without the grass deflector mounted in place, you and others are exposed to blade contact and thrown debris. Contact with the rotating mower blade(s) and thrown debris will cause injury or death.

- Never remove the grass deflector from the mower because the grass deflector routes material down toward the turf. If the grass deflector is ever damaged, replace it immediately.
- Never put your hands or feet under the mower.
- Never operate the mower with the deflector removed from the cutting unit or tied/blocked in a raised position.

Note: The deflector is spring loaded into its downward normal operating position (Fig. 20), but the operator can temporarily swing it out of the way to facilitate loading in a trailer or when otherwise necessary.



Figure 20

1. Deflector in lowest position

Maintenance

Note: Determine the left and right sides of the machine from the normal operating position.

Recommended Maintenance Schedule

Maintenance Service Interval	Maintenance Procedure
After first 2 hours	<ul style="list-style-type: none">• Tighten the castor wheel nuts.
After first 10 hours	<ul style="list-style-type: none">• Tighten the castor wheel nuts.• Torque the blade bolts.
Daily	<ul style="list-style-type: none">• Check the blades.• Lubricate the castor arm bushings.• Lubricate the castor wheel bearings.
Every 50 hours	<ul style="list-style-type: none">• Tighten the castor wheel nuts.• Torque the blade bolts.• Lubricate the grease fittings.• Clean under the cutting unit belt covers.• Check the blade drive belt adjustment.• Check the gear box oil.
Every 400 hours	<ul style="list-style-type: none">• Change the gear box oil level.

Greasing the Bearings, Bushings, and Gear Box

The cutting unit must be lubricated regularly. If the machine is operated under normal conditions, lubricate the castor bearings and bushings with No. 2 general purpose lithium base grease or molybdenum base grease, after every 8 hours of operation or daily, whichever comes first. All other bearings, bushings and the gear box must be lubricated after every 50 hours of operation.

1. The cutting unit has bearings and bushings that must be lubricated. Lubricate the following areas:
 - caster spindle bushings (Fig. 21 and 22)
 - caster wheel bearings (Fig. 22 and 23)
 - blade spindle bearings (Fig. 24)
 - right and left push arm ball joints (Fig. 24)
2. Position the machine and cutting unit on a level surface and lower the cutting unit. Remove the dipstick/fill plug from the top of the gear box (Fig. 25) and make sure that the lubricant is between the marks on the dipstick. If the lubricant level is low, add SAE 80–90 wt. gear lube until the level is between the marks.

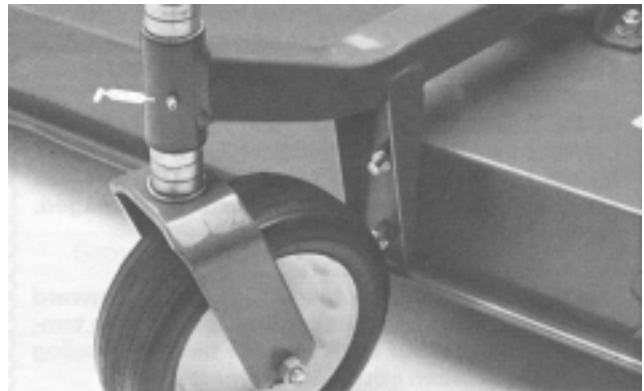

Figure 21



Figure 22

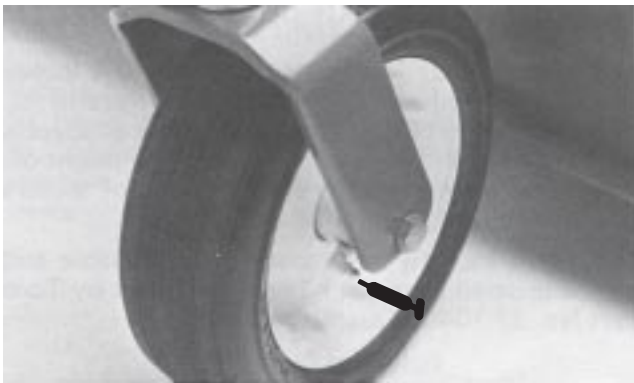

Figure 23



Figure 24

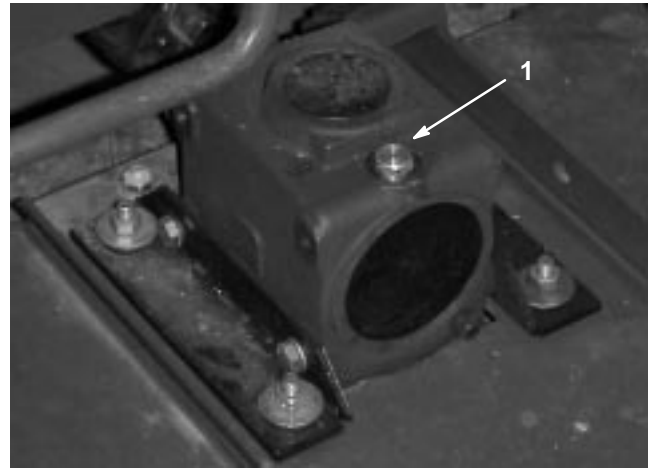

Figure 25

1. Fill/check plug

Separating the Cutting Unit from the Traction Unit

1. Position the machine on a level surface, lower the cutting unit to the shop floor, shut the engine off, and engage the parking brake.
2. Remove the self-tapping screws securing the shield to the top of the cutting unit and set the shield aside.
3. Drive the roll pin out of the yoke and input shaft of the gear box (Fig. 26). Also, loosen the capscrews and locknuts. Slide the yoke off of the input shaft. If the traction unit will be used without the cutting unit, drive the roll pin out of the yoke at the PTO pivot shaft and remove the entire universal shaft from the traction unit.

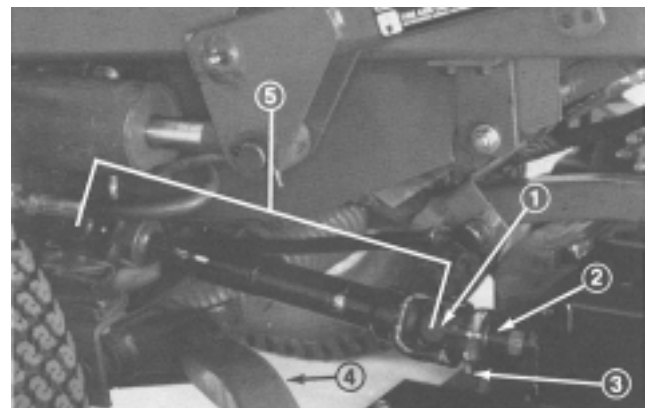

Figure 26

- | | |
|---------------------------|------------------------|
| 1. PTO yoke | 4. Right-hand push arm |
| 2. Roll pin | 5. Yokes in phase |
| 3. Capscrews and locknuts | |



Danger



If the engine is started and the PTO shaft is allowed to rotate, serious injury could result.

Do not start the engine and engage the PTO lever when the PTO shaft is not connected to the gear box on the cutting unit.

4. Disconnect the spring from the lift cylinder cotter pin. Remove the cotter pins and clevis pins securing the lift chains to the lift arm.



Warning



The right-hand push arm is spring-loaded to about 100 lb. (445 N) and the left-hand push arm is spring-loaded to about 150 lb. (667 N). Sudden release of the push arm could result in injury.

Another person is needed to push the arm down.

5. Have another person push down on the right push arm while you remove the capscrews, flat washers, lock washers, and nuts securing the ball joint mount to the castor arm on the cutting unit (Fig. 26). Now the other person can carefully allow the push arm to move upward, which will gradually release the 100 lb. (445 N) of spring load.
6. Have another person push down on the left push arm while you remove the capscrews, flat washers, lock washers, and nuts securing the ball joint mount to the mount bracket on the cutting unit (Fig. 27). Now the other person can carefully allow the push arm to move upward, which will gradually release the 150 lb. (667 N) of spring load.

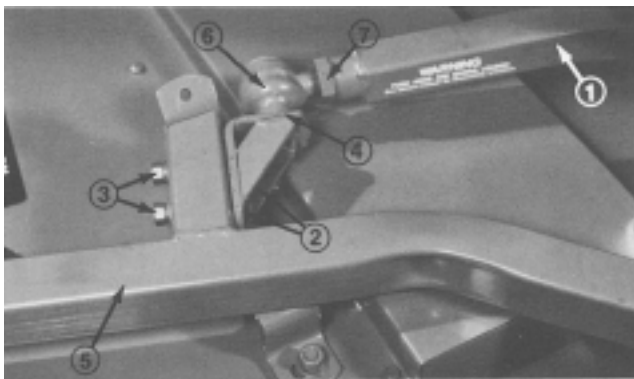

Figure 27

- | | |
|-----------------------------|---------------|
| 1. Left-hand push arm | 5. Castor arm |
| 2. Capscrew and flat washer | 6. Ball joint |
| 3. Flange locknut | 7. Jam nut |
| 4. Ball joint mount | |

7. Roll the cutting unit away from the traction unit.

Mounting the Cutting Unit to the Traction Unit

1. Position the machine on a level surface and shut the engine off.
2. Move the cutting unit into position in front of the traction unit.



Warning



The right-hand push arm is spring-loaded to about 100 lb. (445 N) and the left-hand push arm is spring-loaded to about 150 lb. (667 N). Sudden release of the push arm could result in injury.

Another person is needed to push the arm down.

3. Slide a large flat washer (1/2 in.) onto both capscrews (7/16 x 3 in.).
4. Have another person carefully push down on the right-hand push arm until the holes in the ball joint mount line up with the holes in the castor arm. Secure the ball joint mount to the castor arm with 2 capscrews with large flat washers, a flat washer (7/16 in.), 2 lock washers, and nuts (7/16 in.). The heads of the capscrews and large flat washers must be on the outside of the castor arm.
5. Slide the flat washers (7/16 in.) onto the 2 capscrews (7/16 x 3 in.).
6. Have another person carefully push down on the left-hand push arm until the holes in the ball joint mount are in line with the holes in the mount bracket on the cutting unit. Immediately slide a 4 x 4 in. (102 x 102 mm) block of wood between the top of the push arm and the underside of the chassis



Warning



Make sure that the wooden block does not accidentally slip out.

7. Secure the ball joint mount to the mount bracket with 2 capscrews, flat washers, and flange locknuts (7/16 in.). The head of the capscrews and flat washers must contact the ball joint mount.
8. Connect the PTO shaft to the gear box with a roll pin and 2 capscrews and nuts, install the shield, and connect the lift chains to the lift arm; refer to Connecting the PTO Shaft and Installing the Lift Chains, page 13.

Replacing the Blade Drive Belts

1. Lower the cutting unit to the shop floor. Remove the covers on the top of the cutting unit and set the covers aside. Loosen the idler pulleys to release the tension on the belts.
2. Remove the carriage bolts, lock washers, and nuts holding the gear box in place. Lift the gear box off of the mounting plate and lay it on top of the cutting unit.
3. Remove the belts from the spindle pulleys.
4. Mount a belt on the lower pulley groove of the left spindle, slide the belt under the belt idler mount plate, and install it around the center spindle pulley. Tension the belt by levering the idler pulley against the belt and tighten the idler pulley flange nut (Fig. 28).

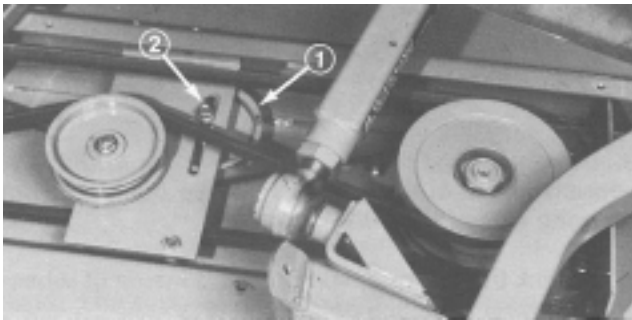

Figure 28

1. Lower belt idler
2. Flange nut

5. Place the right spindle belt under the gear box mount plate and the opposite end on top of the right spindle pulley. Place the left spindle belt under the gear box mount plate and the opposite end on top of the left spindle pulley. Mount the gear box and loop the belts around the gear box pulley.
6. Feed the right and left spindle belts over the pulleys by rotating the cutter blades. Tighten the gear box mounting fasteners.
7. Tension the idler pulleys against both belts. Install the covers on top of the cutting unit.

Servicing the Bushings in the Caster Arms

The caster arms have bushings pressed into the top and bottom portion of the tube and after many hours of operation, the bushings will wear. To check the bushings, move the castor fork back and forth and from side-to-side. If the castor spindle is loose inside the bushings, the bushings are worn and must be replaced.

1. Raise the cutting unit and block it so that it cannot accidentally fall.
2. Remove the tensioning cap and spacers from the top of the castor spindle.
3. Pull the castor spindle out of the mounting tube. Allow the spacer(s) and thrust washer to remain on the bottom of the spindle to ensure the same height-of-cut when the castor spindle is installed.
4. Insert a pin punch into the top or bottom of the mounting tube and drive the bushing out of the tube (Fig. 29). Also drive the other bushing out of the tube. Clean the inside of the tubes to remove dirt.

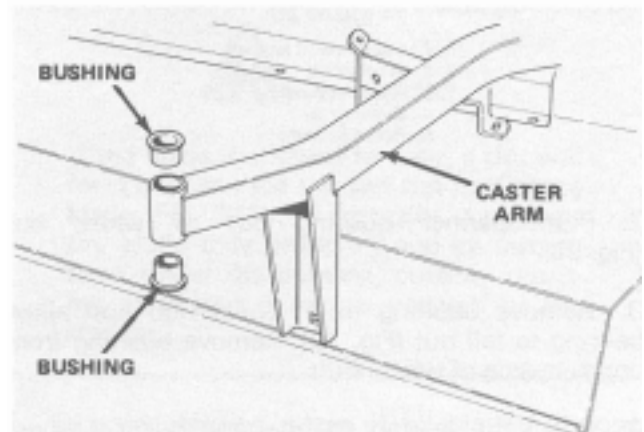

Figure 29

5. Apply grease to the inside and outside of the new bushings. Using a hammer and flat plate, drive the bushings into the mounting tube.
6. Inspect the castor spindle for wear and replace it if it is damaged.
7. Push the castor spindle through the bushings and mounting tube. Slide the spacers onto the spindle. Install the tensioning cap onto the castor spindle to retain all parts in place.

Servicing the Rear Castor Wheel and Bearing

The rear castor wheels rotate on high-quality roller bearings which are supported by spanner bushings. Even after many hours of use, provided that the bearing was kept well-lubricated, bearing wear will be minimal. However, failure to keep the bearings lubricated will cause rapid wear. A wobbly castor wheel usually indicates a worn bearing.

1. Remove the capscrew and locknut holding the castor wheel and 2 washers between the castor fork (Fig. 30).
2. Pull the spanner bushing out of the wheel hub (Fig. 30).

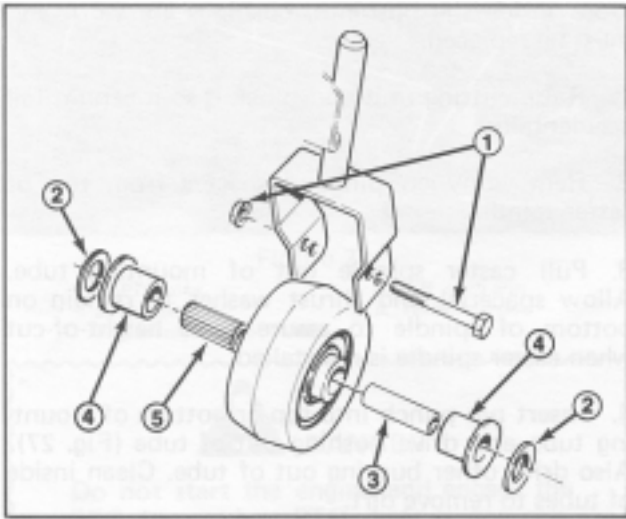

Figure 30

- | | |
|-------------------------|-------------------|
| 1. Capscrew and locknut | 4. Bushing (2) |
| 2. Washer (2) | 5. Roller bearing |
| 3. Spanner bushing | |

3. Remove the bushing from the wheel hub and allow the bearing to fall out (Fig. 30). Remove the bushing from the opposite side of the wheel hub.
4. Check the bearing, spanner, and inside of the wheel hub for wear. Replace damaged parts.
5. To assemble the castor wheel, push the bushing into the wheel hub. Slide the bearing into the wheel hub. Push the other bushing into the open end of the wheel hub to captivate the bearing inside the wheel hub.
6. Carefully slide the spanner through the bushings and wheel hub.
7. Install the castor wheel assembly and 2 washers between the castor fork, and secure all parts in place with the capscrew and locknut.
8. Lubricate the castor wheel bearing through the grease fitting, using No. 2 general purpose lithium grease.

Servicing the Front Wheel Castor Bearing

The front castor wheels rotate on high-quality roller bearings which are supported by spanner bushings. Even after many hours of use, provided that the bearing was kept well-lubricated, bearing wear will be minimal. However, failure to keep the bearings lubricated will cause rapid wear. A wobbly castor wheel usually indicates a worn bearing.

1. Remove the capscrew and locknut holding the castor wheel and 2 washers between the castor fork (Fig. 31).
2. Pull the spanner bushing out of the wheel hub (Fig. 31).

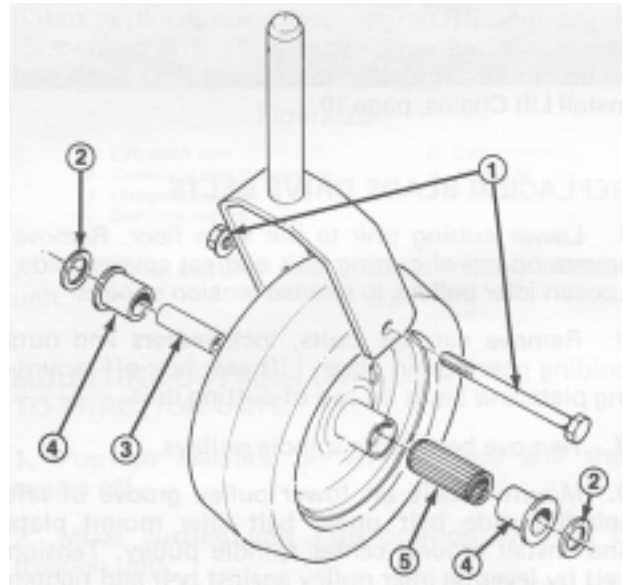

Figure 31

- | | |
|-------------------------|-------------------|
| 1. Capscrew and locknut | 4. Bushing (2) |
| 2. Washer (2) | 5. Roller bearing |
| 3. Spanner bushing | |

3. Remove the bushing from the wheel hub and allow the bearing to fall out (Fig. 31). Remove the bushing from the opposite side of the wheel hub.
4. Check the bearing, spanner, and inside of the wheel hub for wear. Replace damaged parts.
5. To assemble the castor wheel, push the bushing into the wheel hub. Slide the bearing into the wheel hub. Push the other bushing into the open end of the wheel hub to captivate the bearing inside the wheel hub.
6. Carefully slide the spanner through the bushings and wheel hub.
7. Install the castor wheel assembly and 2 washers between the castor fork, and secure all parts in place with the capscrew and locknut.
8. Lubricate the castor wheel bearing through the grease fitting, using No. 2 general purpose lithium grease.

Removing the Cutting Blade

The blade must be replaced if a solid object is hit, the blade is out-of-balance, worn, or bent. Always use genuine Toro replacement blades to ensure safety and optimum performance. Never use blades made by other manufacturers because they could be dangerous.

! **Danger** !

A worn or damaged blade can break, and a piece of the blade could be thrown into the operator's or bystander's area, resulting in serious personal injury or death.

- **Inspect the blade periodically for wear or damage.**
- **Do not try to straighten a blade that is bent.**
- **Never weld a broken or cracked blade.**
- **Replace a worn or damaged blade with a new Toro blade to ensure continued safety certification of the product.**

1. Raise the cutting unit to the highest position, shut the engine off, and engage the parking brake. Block the cutting unit to prevent it from accidentally falling.
2. Grasp the end of the blade using a rag or thickly padded glove. Remove the special screw, Belleville washer, and blade from the spindle assembly (Fig. 32).

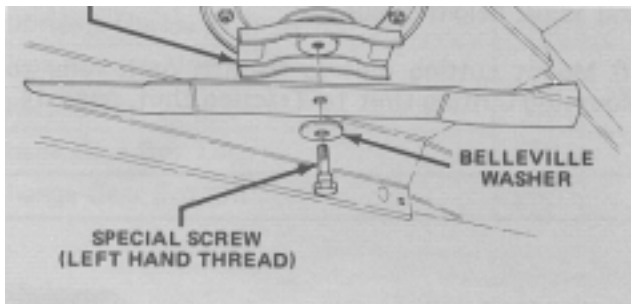

Figure 32

Note: The special screw has a left-hand thread.

3. To install the blade, assemble the parts in reverse order, and make sure that the blade sail is facing up. Tighten the special screw to 75 to 100 ft.-lb. (102 to 136 N·m).

Inspecting and Sharpening the Blade

1. Raise the cutting unit to the highest position, shut the engine off, and engage the parking brake. Block the cutting unit to prevent it from accidentally falling.
2. Examine the cutting ends of the blade carefully, especially where the flat and curved parts of the blade meet (Fig. 33-A). Since sand and abrasive material can wear away the metal that connects the flat and curved parts of the blade, check the blade before using the machine. If wear is noticed (Fig. 33-B), replace the blade; refer to Removing the Cutting Blade, page 21.

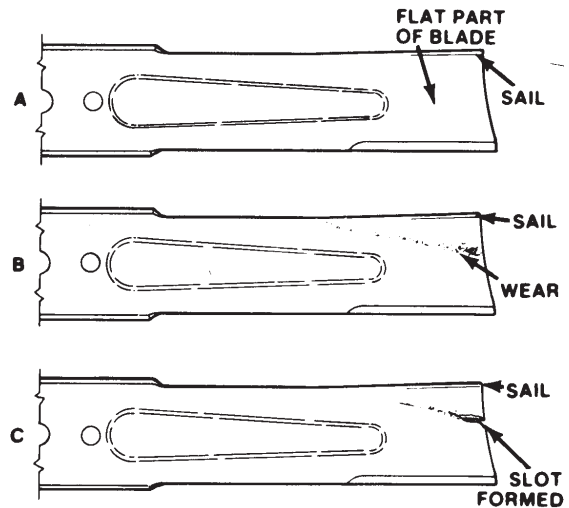

Figure 33

! **Warning** !

If the blade is allowed to wear, a slot will form between the sail and flat part of the blade (Fig. 33-C). Eventually, a piece of the blade may break off and be thrown from under the housing, possibly resulting in serious injury to yourself or bystanders.

- **Inspect the blade periodically for wear or damage.**
- **Replace a worn or damaged blade with a new Toro blade to ensure continued safety certification of the product.**

3. Examine the cutting edges of all blades. Sharpen the cutting edges if they are dull or nicked. Sharpen only the top side of the cutting edge and maintain the original cutting angle to ensure sharpness (Fig. 34). The blade will remain balanced if the same amount of metal is removed from both cutting edges.

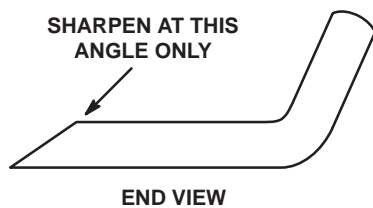

Figure 34

4. To check the blade for being straight and parallel, lay the blade on a level surface and check the ends. The ends of the blade must be slightly lower than the center, and the cutting edge must be lower than the heel of the blade. This blade will produce good a quality-of-cut and require minimal power from the engine. By contrast, a blade that is higher at the ends than the center, or the cutting edge is higher than the heel of the blade, is warped or bent and must be replaced.
5. To install the blade, assemble the parts in reverse order, and make sure that the blade sail is facing up. Tighten the special screw to 75–100 ft.-lb. (102 to 136 N·m).

Checking and Correcting Mismatch of Blades

If there is mismatch between the blades, the grass will appear streaked when it is cut. This problem can be corrected by making sure that the blades are straight and all blades are cutting on the same plane.

1. Using a 3 foot (1 m) long carpenters level, find a flat surface on the shop floor.
2. Set the rear castor wheels in the upper hole of the castor forks and adjust the height-of-cut so that all 6 height-of-cut spacers are below the castor arm.
3. Lower the cutting unit onto a flat surface. Remove the covers from the top of the cutting unit. Loosen the idler pulleys to release the tension against all 3 belts.
4. Rotate the blades until the ends face forward and backward. Measure from the floor to the front tip of the cutting edge and remember this dimension. Then rotate the same blade so that opposite end is forward and measure again. The difference between the dimensions must not exceed 1/8 inch (3 mm). If the difference exceeds 1/8 inch (3 mm), replace the blade because it is bent. Make sure to measure all three blades.
5. Compare the measurements of the outer blades with the center blade. The center blade must not be more than 3/8 inch (10 mm) lower than the outer blades. If the center blade is more than 3/8 inch (10 mm) lower than the outer blades, proceed to step 7 and add shims between the spindle housing and bottom of the cutting unit.

6. Rotate the blades so that the tips line up with one another. The tips of the adjacent blades must be within 1/8 inch (3 mm) of each other. If the tips are not within 1/8 inch (3 mm) of each other, proceed to step 7 and add shims between the spindle housing and bottom of the cutting unit.
 7. Remove the capscrews, flat washers, lock washers, and nuts from the outer spindle, in the area where the shims must be added. To raise or lower the blade, add a shim, Part No. 3256-24, between the spindle housing and bottom of the cutting unit. Continue to check the alignment of the blade and add shims until the tips of the blades are within the required dimension.
- Important** Do not use more than 3 shims at any one hole location. Use decreasing numbers of shims in adjacent holes if more than one shim is added to any 1 hole location.
8. Tension the idler pulleys against all 3 belts. Also install the covers to the top of the cutting unit.
 9. Set the rear castor wheels in the lower holes in the castor forks if the height-of-cut is above 1 inch (25 mm) and adjust the height-of-cut.
 10. Mount the cutting unit to the traction unit; refer to Mounting the Cutting Unit to the Traction Unit, page 18.

Troubleshooting

UNIT WILL NOT CUT OR CUTS POORLY

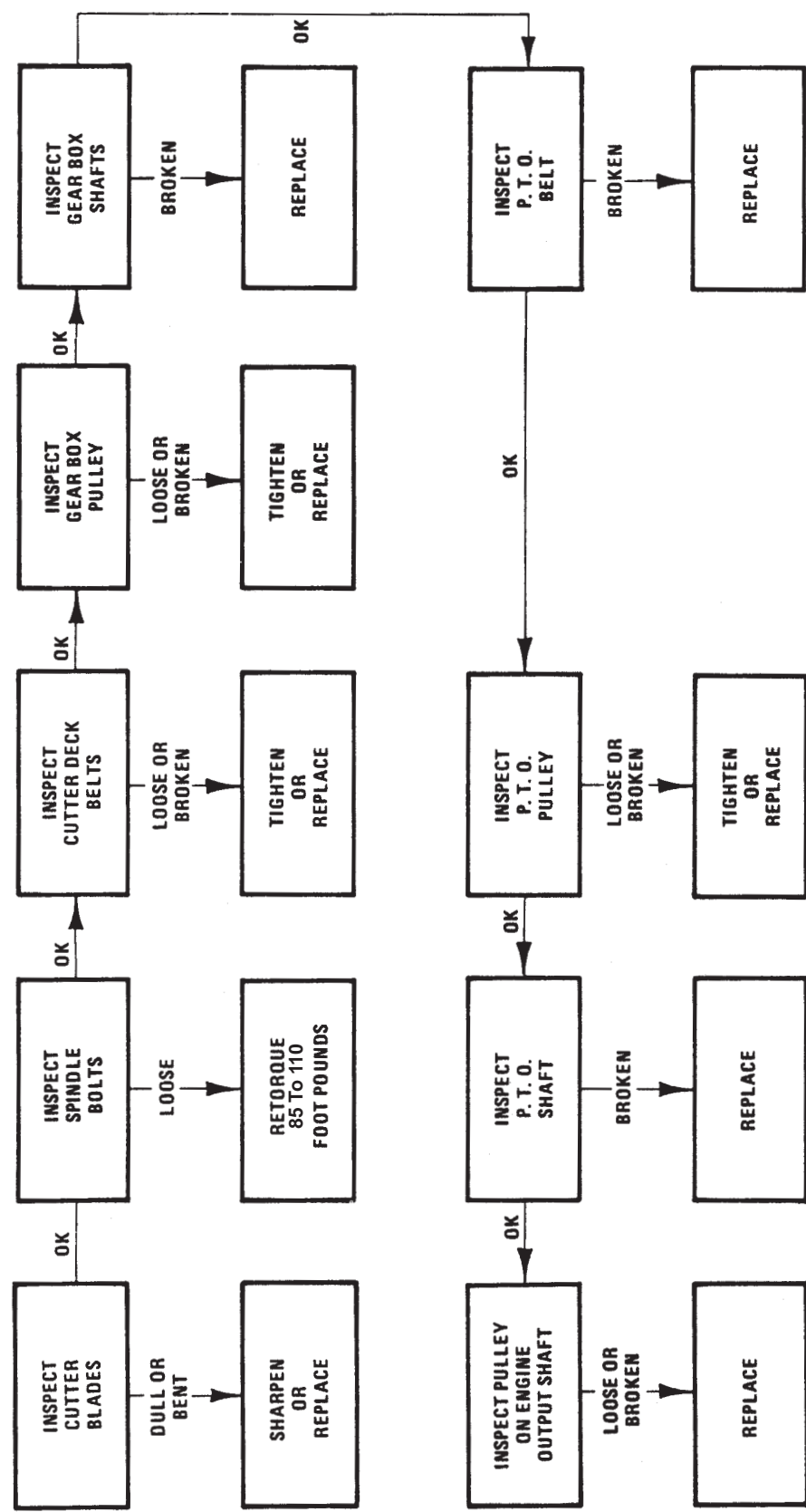



The Toro General Commercial Products Warranty

A Two-Year Limited Warranty

Conditions and Products Covered

The Toro Company and its affiliate, Toro Warranty Company, pursuant to an agreement between them, jointly warrant your Toro Commercial Product ("Product") to be free from defects in materials or workmanship for two years or 1500 operational hours*, whichever occurs first. Where a warrantable condition exists, we will repair the Product at no cost to you including diagnosis, labor, parts, and transportation. This warranty begins on the date the Product is delivered to the original retail purchaser.

* Product equipped with hour meter

Instructions for Obtaining Warranty Service

You are responsible for notifying the Commercial Products Distributor or Authorized Commercial Products Dealer from whom you purchased the Product as soon as you believe a warrantable condition exists.

If you need help locating a Commercial Products Distributor or Authorized Dealer, or if you have questions regarding your warranty rights or responsibilities, you may contact us at:

Toro Commercial Products Service Department
Toro Warranty Company
8111 Lyndale Avenue South
Bloomington, MN 55420-1196
952-888-8801 or 800-982-2740
E-mail: commercial.service@toro.com

Owner Responsibilities

As the Product owner, you are responsible for required maintenance and adjustments stated in your operator's manual. Failure to perform required maintenance and adjustments can be grounds for disallowing a warranty claim.

Items and Conditions Not Covered

Not all product failures or malfunctions that occur during the warranty period are defects in materials or workmanship. This express warranty does not cover the following:

- Product failures which result from the use of non-Toro replacement parts, or from installation and use of add-on, modified, or unapproved accessories
- Product failures which result from failure to perform required maintenance and/or adjustments
- Product failures which result from operating the Product in an abusive, negligent or reckless manner
- Parts subject to consumption through use unless found to be defective. Examples of parts which are consumed, or used up, during normal Product operation include, but are not limited to, blades, reels, bedknives, tines, spark plugs, castor wheels, tires, filters, belts, etc.

Countries Other than the United States or Canada

Customers who have purchased Toro products exported from the United States or Canada should contact their Toro Distributor (Dealer) to obtain guarantee policies for your country, province, or state. If for any reason you are dissatisfied with your Distributor's service or have difficulty obtaining guarantee information, contact the Toro importer. If all other remedies fail, you may contact us at Toro Warranty Company.

- Failures caused by outside influence. Items considered to be outside influence include, but are not limited to, weather, storage practices, contamination, use of unapproved coolants, lubricants, additives, or chemicals, etc.
- Normal "wear and tear" items. Normal "wear and tear" includes, but is not limited to, damage to seats due to wear or abrasion, worn painted surfaces, scratched decals or windows, etc.

Parts

Parts scheduled for replacement as required maintenance are warranted for the period of time up to the scheduled replacement time for that part.

Parts replaced under this warranty become the property of Toro. Toro will make the final decision whether to repair any existing part or assembly or replace it. Toro may use factory remanufactured parts rather than new parts for some warranty repairs.

General Conditions

Repair by an Authorized Toro Distributor or Dealer is your sole remedy under this warranty.

Neither The Toro Company nor Toro Warranty Company is liable for indirect, incidental or consequential damages in connection with the use of the Toro Products covered by this warranty, including any cost or expense of providing substitute equipment or service during reasonable periods of malfunction or non-use pending completion of repairs under this warranty. Except for the Emissions warranty referenced below, if applicable, there is no other express warranty. All implied warranties of merchantability and fitness for use are limited to the duration of this express warranty.

Some states do not allow exclusions of incidental or consequential damages, or limitations on how long an implied warranty lasts, so the above exclusions and limitations may not apply to you.

This warranty gives you specific legal rights, and you may also have other rights which vary from state to state.

Note regarding engine warranty: The Emissions Control System on your Product may be covered by a separate warranty meeting requirements established by the U.S. Environmental Protection Agency (EPA) and/or the California Air Resources Board (CARB). The hour limitations set forth above do not apply to the Emissions Control System Warranty. Refer to the Engine Emission Control Warranty Statement printed in your operator's manual or contained in the engine manufacturer's documentation for details.