



ProLine 21-inch Recycler[®]

Walk Power Lawn Mower

Model No. 22168—240000001 and Up

Operator's Manual



Warning



CALIFORNIA

Proposition 65 Warning

The engine exhaust from this product contains chemicals known to the State of California to cause cancer, birth defects, or other reproductive harm.

Important This engine is not equipped with a spark arrester muffler. It is a violation of California Public Resource Code Section 4442 to use or operate this engine on any forest-covered, brush-covered, or grass-covered land. Other states or federal areas may have similar laws.

This spark ignition system complies with Canadian ICES-002.

Ce système d'allumage par étincelle de véhicule est conforme à la norme NMB-002 du Canada.

The enclosed Engine Owner's Manual is supplied for information regarding The U.S. Environmental Protection Agency (EPA) and the California Emission Control Regulation of emission systems, maintenance and warranty.

Keep this engine Owner's Manual with your unit. Should this engine Owner's Manual become damaged or illegible, replace immediately. Replacements may be ordered through the engine manufacturer.

Contents

	Page
Introduction	2
Safety	3
Safe Operating Practices	3
Toro Lawn Mower Safety	4
Safety and Instruction Decals	5
Assembly	6
Loose Parts	6
Installing the Handle	7
Installing the Discharge Tunnel Plug	7
Before Starting	8
Filling the Crankcase with Oil	8
Filling the Fuel Tank with Gasoline	8
Reviewing the Maintenance Schedule	9
Operation	10
Controls	10
Starting the Engine	10
Stopping the Engine	10
Using the Self-propel Drive	10

	Page
Using the Discharge Tunnel Plug	11
Checking the Blade Brake Clutch	11
Adjusting the Cutting Height	13
Using the Grass Bag	13
Operating Tips	14
Maintenance	16
Recommended Maintenance Schedule	16
Checking the Engine Oil Level	17
Checking the Blade Brake Clutch	17
Cleaning under the Housing	17
Cleaning the Discharge Tunnel and Plug	18
Servicing the Air Cleaner	18
Maintaining the Blade	19
Cleaning the Blade Brake Clutch Shield	20
Cleaning under the Belt Cover	21
Lubricating the Pivot Arms	21
Adjusting the Self-propel Drive	21
Changing the Engine Oil	22
Servicing the Spark Plug	22
Lubricating the Gear Case	23
Adjusting the Blade Brake Cable	23
Servicing the Wheels	23
Storage	24
Preparing the Fuel System	24
Preparing the Engine	24
General Information	24
Removing the Lawn Mower from Storage	25
Accessories	25
Troubleshooting	25
The Toro Total Coverage Guarantee	28

Introduction

Read this manual carefully to learn how to operate and maintain your product properly. The information in this manual can help you and others avoid injury and product damage. Although Toro designs and produces safe products, you are responsible for operating the product properly and safely.

You may contact Toro directly at www.Toro.com for product and accessory information, help finding a dealer, or to register your product.

Whenever you need service, genuine Toro parts, or additional information, contact an Authorized Service Dealer or Toro Customer Service and have the model and serial numbers of your product ready. Figure 1 illustrates the location of the model and serial numbers on the product.

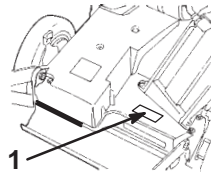

Figure 1

1. Location of the model and serial numbers

Write the product model and serial numbers in the space below:

Model No. _____
Serial No. _____

This manual identifies potential hazards and has special safety messages that help you and others avoid personal injury and even death. **Danger**, **Warning**, and **Caution** are signal words used to identify the level of hazard. However, regardless of the hazard, be extremely careful.

Danger signals an extreme hazard that **will** cause serious injury or death if you do not follow the recommended precautions.



Warning signals a hazard that **may** cause serious injury or death if you do not follow the recommended precautions.

Caution signals a hazard that may cause minor or moderate injury if you do not follow the recommended precautions.

This manual uses two other words to highlight information. **Important** calls attention to special mechanical information and **Note**: emphasizes general information worthy of special attention.

Safety

This lawn mower meets or exceeds the CPSC blade safety requirements for walk-behind rotary lawn mowers and the B71.4 specifications of the American National Standards Institute in effect at the time of production.

	Warning	
<p>Engine exhaust contains carbon monoxide, an odorless, deadly poison that can kill you.</p> <p>Do not run the engine indoors or in an enclosed area.</p>		

To ensure maximum safety and best performance, and to gain knowledge of the product, it is essential that you and any other operator of the lawn mower read and understand the contents of this manual before the engine is ever started.

 This is the safety alert symbol. It is used to alert you to potential personal injury hazards. Obey all safety messages that follow this symbol to avoid possible injury or death.

Improperly using or maintaining this lawn mower could result in injury or death. To reduce this potential, comply with the following safety instructions.

Safe Operating Practices

The following instructions are from the ANSI/OPEI B71.4–1999 standard.

Training

- Read the Operator's Manual and other training material. If the operator(s) or mechanic(s) can not read English it is the owner's responsibility to explain this material to them.
- Become familiar with the safe operation of the equipment, operator controls, and safety signs.
- All operators and mechanics should be trained. The owner is responsible for training the users.
- Never let children or untrained people operate or service the equipment. Local regulations may restrict the age of the operator.
- The owner/user can prevent and is responsible for accidents or injuries occurring to themselves, other people, or property.

Preparation

- Only use accessories and attachments approved by the manufacturer.
- Wear appropriate clothing including hard hat, safety glasses, and ear protection. Long hair, loose clothing or jewelry may get tangled in moving parts.

- Inspect the area where the equipment is to be used and remove all objects such as rocks, toys and wire which can be thrown by the machine.
- Use extra care when handling gasoline and other fuels. They are flammable and vapors are explosive.
 - Use only an approved container.
 - Never remove gas cap or add fuel with engine running. Allow engine to cool before refueling. Do not smoke.
 - Never refuel or drain the machine indoors.
- Check that operator's presence controls, safety switches and shields are attached and functioning properly. Do not operate unless they are functioning properly.

Operation

- Never run an engine in an enclosed area.
- Only operate in good light, keeping away from holes and hidden hazards.
- Only start engine from the operator's position.
- Be sure of your footing, especially when backing up. Walk, don't run. Never operate on wet grass. Reduced footing could cause slipping.
- Slow down on hillsides. Be sure to travel side to side on hillsides. Turf conditions can affect the machine's stability. Use caution while operating near drop-offs.
- Do not change the engine governor setting or overspeed the engine.
- Stop on level ground and shut off engine before leaving the operator's position for any reason including emptying the catcher or unclogging the chute.
- Stop equipment and inspect blade after striking objects or if an abnormal vibration occurs. Make necessary repairs before resuming operations.
- Keep hands and feet away from the cutting units.
- Look behind and down before backing up to be sure of a clear path.
- Keep pets and bystanders away.
- Slow down and use caution when crossing roads and sidewalks.
- Stop blade if you are not mowing.
- Be aware of the mower discharge direction and do not point it at anyone.
- Do not operate the mower under the influence of alcohol or drugs.

- Use care when approaching blind corners, shrubs, trees, or other objects that may obscure vision.
- Do not operate the lawn mower without either the grass catcher or the guard in place.

Maintenance and Storage

- Stop engine and disconnect spark plug wire. Wait for all movement to stop before adjusting, cleaning or repairing.
- Clean grass and debris from cutting unit, drive, muffler, and engine to help prevent fires. Clean up oil or fuel spillage.
- Let engine cool before storing and do not store near flame.
- Shut off fuel while storing or transporting. Do not store fuel near flames or drain indoors.
- Never allow untrained personnel to service machine.
- Remove spark plug wire before making any repairs.
- Use care when checking blade. Wrap the blade or wear gloves, and use caution when servicing them. Only replace blade. Never straighten or weld it.
- Keep hands and feet away from moving parts. If possible, do not make adjustments with the engine running.
- Keep all parts in good working condition and all hardware tightened. Replace all worn or damaged decals.

Toro Lawn Mower Safety

The following list contains safety information specific to Toro products or other safety information that you must know that is not included in the ANSI/OPEI standard.

This product is capable of amputating hands and feet, and of throwing objects. Always follow all safety instructions to avoid serious injury or death.

Use this product only for cutting and mulching grass, or, when equipped with a grass bagger, for catching cut grass.

- Stop the lawn mower if anyone enters the area.
- Do not operate the lawn mower without either the grass catcher or the guard in place.
- Do not touch the lawn mower or attachment parts which may be hot from operation. Allow the lawn mower to cool down before attempting to maintain, adjust, or service it.

Safety and Instruction Decals



Safety decals and instructions are easily visible to the operator and are located near any area of potential danger. Replace any decal that is damaged or lost.



43-8480

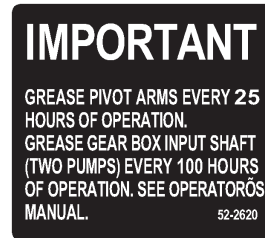

52-2620



63-9060



68-7410



94-9418



74-1970

- 1. Transmission speeds
- 2. Neutral



98-4387

- 1. Warning—wear hearing protection.



92-1779



104-8582

Assembly

Note: Determine the left and right sides of the machine from the normal operating position.

Loose Parts

DESCRIPTION	QTY.	USE
Handle	1	Installing the handle
Bolts, 5/16–18 x 1-1/4 in.	2	
Bolts, 5/16–18 x 1-1/2 in.	2	
Carriage bolt	1	
Washers	4	
Locknuts	2	
Thin nylon insert locknuts	2	
Bag support rod	1	
Bag aligning plate	1	
Cap locknuts	3	
Cable tie	1	

Installing the Handle

1. Mount the handle to the outside of the lawn mower housing (using the bottom hole) with two bolts (5/16–18 x 1–1/4 in.), washers, and thin nylon insert locknuts (Fig. 2).

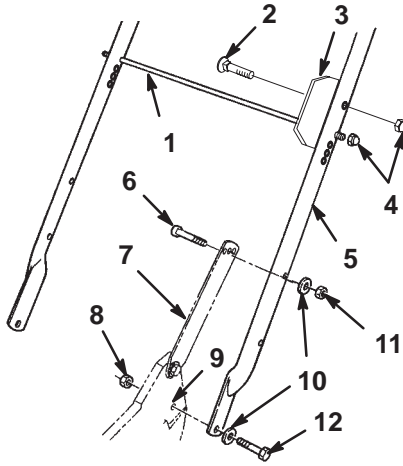

m-3850

Figure 2

- | | |
|--------------------------------|----------------------------------|
| 1. Bag support rod | 8. Thin nylon insert locknut (2) |
| 2. Carriage bolt | 9. Bottom hole in housing |
| 3. Bag aligning plate | 10. Washer (4) |
| 4. Cap locknuts (3) | 11. Locknut (2) |
| 5. Handle | 12. Bolt, 5/16–18x1-1/2 in. (2) |
| 6. Bolt, 5/16–18x1-1/4 in. (2) | |
| 7. Handle latch (2) | |

2. Secure the handle latches to the handle with two 5/16–18 x 1-1/2 in. bolts, washers, and nylon insert locknuts (Fig. 2).

Note: You can adjust the handle height for comfortable operation. Stand behind the handle to determine the height. To adjust the handle height, position the bolts and the locknuts that secure the handle latches to the handle into the other mounting holes in the handle latches.

3. Slide the bag support rod through the bag aligning plate and into the second from the top mounting holes in the handle, and secure each end with a cap locknut (Fig. 2).
4. Insert the carriage bolt through the bag aligning plate and the top hole on the left side of the handle, and secure it with a cap locknut (Fig. 2).
5. Use a cable tie to secure the control cables to the left handle below the bag support rod.

Installing the Discharge Tunnel Plug

1. Open the discharge door by pulling forward on the handle and moving it rearward (Fig. 3). Hold the discharge door handle to prevent the spring-loaded door from closing while you insert the plug.

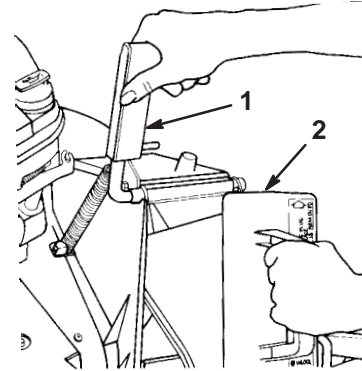

m-262

Figure 3

1. Discharge door handle
2. Plug rotated clockwise

2. Since the plug is slightly wider than the discharge tunnel opening, rotate the plug clockwise slightly while inserting it (Fig. 3).

Note: Ensure that the arrow on the plug decal points upward.

3. Push the plug all the way in until the spring clip on the bottom of the plug clicks into place, locking the plug securely into the discharge tunnel (Fig. 4).

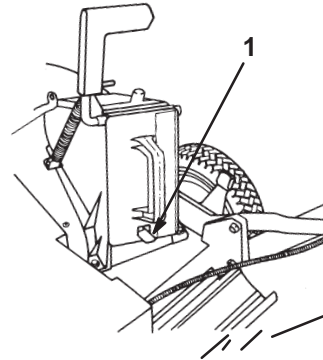

m-275

Figure 4

1. Spring clip

4. Release the discharge door handle to lock the top of the plug.

Before Starting

Filling the Crankcase with Oil

The engine crankcase can hold 22 ounces (0.65 liters) of oil. Use only high-quality SAE 10W-30 weight detergent oil that has the American Petroleum Institute (API) service classification SH, SJ, or equivalent.

Before each use, ensure that the oil level is between the lower limit and upper limit marks on the dipstick (Fig. 5).

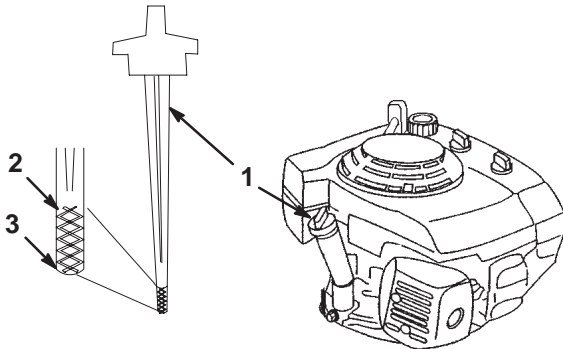

Figure 5

1. Dipstick
2. Upper limit mark
3. Lower limit mark

Note: When the crankcase is empty, pour about three-fourths of the crankcase capacity of oil in the crankcase, then follow the procedure in this section.

To add oil:

1. Move the lawn mower to a level surface.
2. Clean around the dipstick (Fig. 5).
3. Remove the dipstick by rotating the cap counterclockwise and pulling it out.
4. Wipe the dipstick clean with a clean cloth.
5. Insert the dipstick into the filler neck (but **do not rotate the cap clockwise to secure it**), then remove it.
6. Read the oil level on the dipstick (Fig. 5).
7. If the oil level reading is below the lower limit mark on the dipstick, remove the dipstick and **slowly** pour only enough oil into the filler hole to raise the oil level to the upper limit mark on the dipstick (Fig. 5).

Important Do not overfill the crankcase with oil and run the engine; engine damage will result. Drain the excess oil until the oil level reaches the upper limit mark on the dipstick.

8. Insert the dipstick into the filler neck and rotate the cap clockwise until it is tight.

Filling the Fuel Tank with Gasoline

For best results, use clean, fresh, lead-free gasoline with an octane rating of 87 or higher. To ensure freshness, purchase only the quantity of gasoline that you expect to use in 30 days. Using unleaded gasoline results in fewer combustion deposits and longer engine life. You may use leaded gasoline if unleaded gasoline is not available.

Important Do not add oil to the gasoline.

Important Do not use methanol, gasoline containing methanol, gasohol containing more than 10% ethanol, premium gasoline, or white gas. Using these fuels can damage the engine's fuel system.

Important Do not use gasoline that is more than 30 days old.



Danger



In certain conditions, gasoline is extremely flammable and highly explosive. A fire or explosion from gasoline can burn you and others and can damage property.

- **Fill the fuel tank outdoors, in an open area, and when the engine is cold. Wipe up any gasoline that spills.**
- **Do not fill the fuel tank completely full. Add gasoline to the fuel tank until the level is 1/4 to 1/2 in. (6 to 13 mm) below the bottom of the filler neck. This empty space in the tank allows the gasoline to expand.**
- **Never smoke when handling gasoline, and stay away from an open flame or where a spark may ignite the gasoline fumes.**
- **Store gasoline in an approved fuel container and keep it out of the reach of children.**
- **Never buy more than a 30-day supply of gasoline.**



Danger



When fueling, under certain circumstances, a static charge can develop, igniting the gasoline. A fire or explosion from gasoline can burn you and others and damage property.

- Always place gasoline containers on the ground and away from your vehicle before filling.
- Do not fill gasoline containers inside a vehicle or on a truck or trailer bed because interior carpets or plastic truck bed liners may insulate the container and slow the loss of any static charge.
- When practical, remove gasoline-powered equipment from the truck or trailer and refuel the equipment with its wheels on the ground.
- If this is not possible, then refuel such equipment on a truck or trailer from a portable container, not from a gasoline dispenser nozzle.
- If you must use a gasoline dispenser nozzle, keep the nozzle in contact with the rim of the fuel tank or container opening at all times until fueling is complete.

Use a fuel stabilizer/conditioner regularly during operation and storage. A fuel stabilizer/conditioner cleans the engine during operation and prevents gum-like varnish deposits from forming in the engine during periods of storage.

Important Do not use fuel additives other than a fuel stabilizer/conditioner. Do not use fuel stabilizers with an alcohol base such as ethanol, methanol, or isopropanol.

1. Clean around the fuel tank cap (Fig. 6).

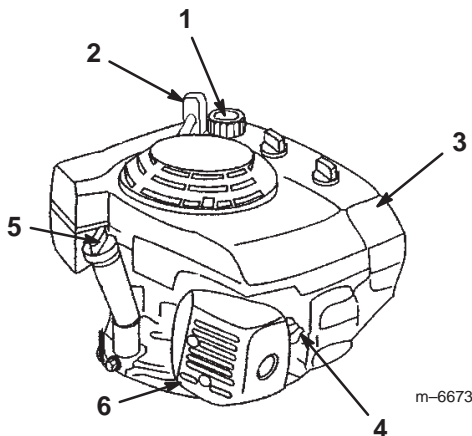

Figure 6

- | | |
|--------------------------|--------------------------------|
| 1. Fuel tank cap | 4. Spark plug |
| 2. Recoil starter handle | 5. Dipstick/Oil fill and drain |
| 3. Air cleaner | 6. Muffler |

2. Remove the fuel tank cap.

3. Fill the fuel tank with unleaded gasoline to within 1/4 to 1/2 inch (6 to 13 mm) from the top of the tank. **Do not fill into the filler neck.**

Note: The fuel tank capacity is 2.1 qt. (2.0 L).

4. Install the fuel tank cap and wipe up any spilled gasoline.

Reviewing the Maintenance Schedule

Review the Recommended Maintenance Schedule on page 16. You may need to perform one or more additional procedures before or soon after you begin operating the lawn mower.

Operation

Note: Determine the left and right sides of the machine from the normal operating position.

Each time before you mow, ensure that the self-propel drive and the control bar operate properly. When you release the control bar, the engine and the blade should stop within 3 seconds. If they do not, contact an Authorized Service Dealer.

!Caution!

This machine produces sound levels in excess of 85dBA at the operator's ear and can cause hearing loss through extended periods of exposure.

Wear hearing protection when operating this machine.

Controls

The control bar, the throttle control, and the starter handle are on the upper handle as shown in Figure 7.

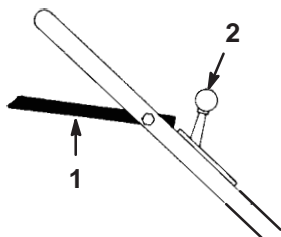

222

Figure 7

1. Control bar

2. Throttle

Starting the Engine

1. Connect the wire to the spark plug (Fig. 6).
2. Open the fuel valve by moving the lever to the **right** (Fig. 8).

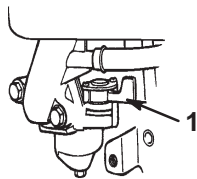

Figure 8

1. Fuel valve

3. Move the throttle control to the **Choke** position (Fig. 7).

Note: Do not use the choke when the engine is warm.

4. Hold the control bar to the handle (Fig. 7).
5. Pull the starter handle (Fig. 7) lightly until you feel resistance, then pull it sharply. Allow the rope to return to the handle slowly.
6. When the engine starts, move the throttle control to the **Fast** position, and set the ground speed control as desired.

Note: If the engine fails to start after three pulls, repeat steps 4 through 6.

Stopping the Engine

Release the control bar. Both the engine and the blade should stop within 3 seconds. If they do not, contact an Authorized Service Dealer.

Note: Close the fuel valve by moving the lever to the **left** if you will not be starting the engine soon afterward.

Using the Self-propel Drive

The lawn mower has three ground speeds. **1** is slow, **2** is medium, and **3** is fast. The ground speed control is located at the rear of the belt cover (Fig. 9).

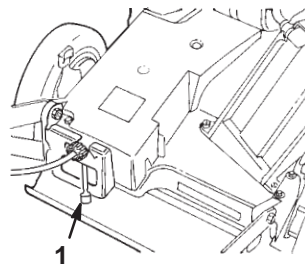

224

Figure 9

1. Ground speed control

1. Move the ground speed control to the **N** (**Neutral**) position.
2. Start the engine.

- Squeeze the control bar against the handle to the **Run/Drive** position (Fig. 10).

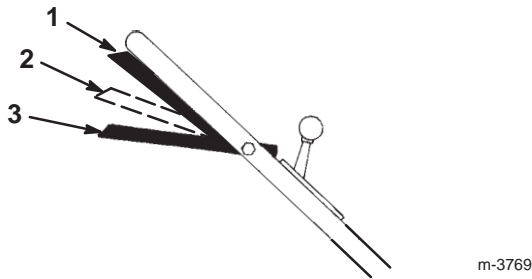

Figure 10

- Run/Drive** position
- Run/Shift** position
- Stop** position

Note: Do not shift speeds while squeezing the control bar against the handle in the **Run/Drive** position; this can damage the transmission. Move the control bar to the **Run/Shift** position (Fig. 10) when you change the ground speed.

Note: You can vary the ground speed by increasing or decreasing the distance between the control bar and the handle. Lower the control bar to decrease the ground speed when you are making a turn or if the lawn mower is moving too fast for you. If you lower the control bar too far, the lawn mower stops self-propelling. Squeeze the control bar closer to the handle to increase the ground speed. When you hold the control bar tight against the handle, the lawn mower self-propels at the maximum ground speed. Move the ground speed control to the **Neutral** position when you use the lawn mower for trimming or whenever you leave the lawn mower.

Using the Discharge Tunnel Plug

- Stop the engine and wait for all moving parts to stop.
- Insert the discharge tunnel plug; refer to Installing the Discharge Tunnel Plug on page 7.
- To remove the plug, move the discharge door handle rearward and lift up the spring clip on the bottom of the plug. When the plug is unlocked, pull it out of the discharge tunnel.

Note: When grass is thick and lush, clippings may collect on and around the discharge tunnel plug. This may make removing the plug difficult. Clean the plug thoroughly after each use.

Checking the Blade Brake Clutch

Check the blade control bail before each use to ensure that the blade brake clutch (BBC) system is operating properly.

Normal Test

- Stop the engine and wait for all moving parts to stop.
- Move the lawn mower onto a paved surface in a non-windy area.
- Set all 4 wheels in to the 2-1/2 in. (64 mm) cutting height setting (Fig. 16).
- Set the ground speed selector to the **N (Neutral)** position.
- Take a half sheet of newspaper and crumple it into a ball small enough to go under the deck (about 3 in. or 76 mm in diameter) as shown in Figure 11.

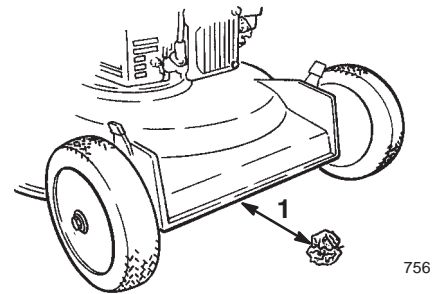

Figure 11

- 5 in. (12.7 cm)

- Place the ball of newspaper 5 in. (12.7 cm) in front of the lawn mower (Fig. 11).
- Start the engine.
- Move the blade control bail down to its lowest position (Fig. 12).

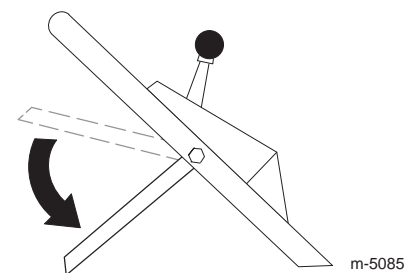

Figure 12

- Lift the blade control bail up to about one inch (2.5 cm) below the handle; refer to position **A** in Figure 13.

Note: The fan-like noise indicates that the lawn mower blade is turning.

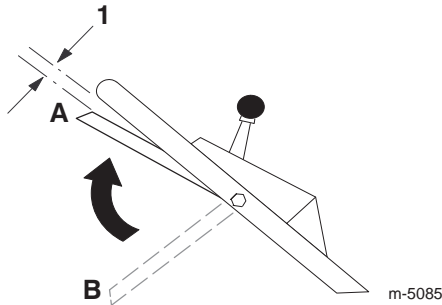

Figure 13

- 1 in. (2.5 cm)

- Release the blade control bail; refer to position **B** in Figure 14. You should hear a “bang.” The blade should stop in 3 seconds.

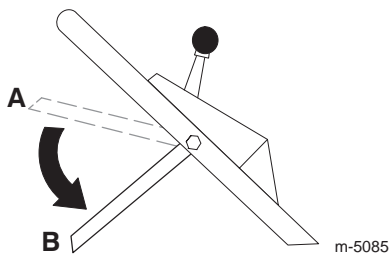

Figure 14

- Immediately push the lawn mower over the newspaper ball.
- Stop the engine and wait for all moving parts to stop.
- Walk around the lawn mower to check for the newspaper ball. If the ball did not go under the deck, repeat steps 6 through 12.
- Pull the lawn mower away from the newspaper. If the newspaper ball unravels or is shredded, the blade has not properly stopped, resulting in an unsafe operating condition. Contact an Authorized Service Dealer.

To check for a problem with the BBC system **before** it affects its normal operation, you can perform the Special Test that follows.

Special Test

- Follow steps 1 through 7 from the Normal Test on page 11.
- Move the blade control bail down to its lowest position (Position **B** in Fig. 14).

- Bring the blade control bail up into the middle position about 5 inches (12.7 cm) below the handle cross bar (Position **C** in Fig. 15).

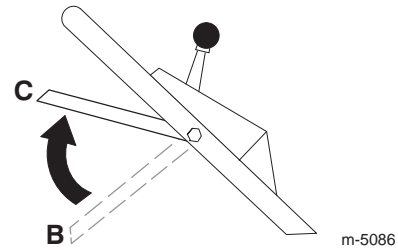

Figure 15

Note: This intermediate position (**C**) is not the normal operating position of the blade control bail. However, it helps to detect a sticking BBC system early enough to prevent an unsafe condition later.

- Release the blade control bail (Position **B** in Fig. 15).

Note: If you hear a loud “bang,” you have raised the blade control bail too high. Repeat steps 2 through 4 above, but do not raise the blade control bail as high as in step 3.

- Immediately push the lawn mower over the newspaper ball.
- Stop the engine and wait for all moving parts to stop.
- Walk around the lawn mower to check for the newspaper ball. If the ball did not go under the deck:
 - Place the ball of newspaper 5 inches (12.7 cm) in front of the lawn mower (Fig. 11).
 - Start the engine.
 - Follow steps 2 through 6 above.
- Pull the lawn mower away from the newspaper. If the newspaper ball unravels or is shredded, the BBC system could be deteriorating to the point where it could result in an unsafe operating condition. Contact an Authorized Service Dealer for an inspection and repair of your lawn mower.



Danger



If the blade brake clutch system is inoperative, the blade will continue to rotate when you release the blade control bail. Contact with blade could occur, causing serious injury.

- **Check the BBC operation before each use.**
- **Never use a BBC-equipped lawn mower with an inoperative safety system.**
- **Take your lawn mower to an Authorized Service Dealer for repair if the safety system fails to operate properly.**

Test Using the Grass Bag

You can use the grass bag to perform an additional test to check the blade brake clutch mechanism:

1. Install the empty grass bag on the discharge tunnel.
2. Start the engine.
3. Push the blade control bail (Fig. 12) down to its lowest position.
4. Lift the blade control bail to the normal blade engaged position about one inch (2.5 cm) below the handle. The bag should begin to inflate, indicating that the blade is engaged and rotating.
5. Release the blade control bail. If the bag does not immediately deflate, it indicates that the blade is still rotating. The blade brake clutch mechanism may be deteriorating, and, if ignored, could result in an unsafe operating condition. Have the lawn mower inspected and serviced by an Authorized Service Dealer.

Adjusting the Cutting Height

Each wheel is adjusted individually with a wheel height adjustment lever. Cutting heights are 3/4 inch (1.9 cm), 1-1/4 inches (3.2 cm), 1-3/4 inches (4.4 cm), 2-1/4 inches (5.7 cm), 2-3/4 inches (7.0 cm), and 3-1/4 inches (8.3 cm).



Danger



Adjusting the cutting height levers could bring your hands into contact with a moving blade and result in serious injury.

- Stop the engine and wait for all moving parts to stop before adjusting the cutting height.
- Do not put your fingers under the housing when adjusting the cutting height.

1. Pull the wheel height adjustment lever toward the wheel (Fig. 16) and move it to the desired setting.

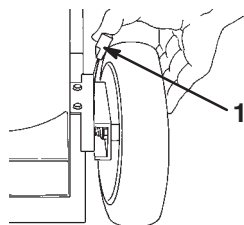

m-225

Figure 16

1. Wheel height adjustment lever

2. Release the wheel height adjustment lever and seat it securely in the notch.
3. Adjust all the wheels to the same cutting height setting.

Using the Grass Bag

Occasionally, you may want to use the grass bag for bagging extra long grass, lush grass, or leaves.

Installing the Grass Bag

1. Stop the engine and wait for all moving parts to stop.
2. Ensure that the discharge door handle is fully forward and that the pin is engaged in the catch (Fig. 17).

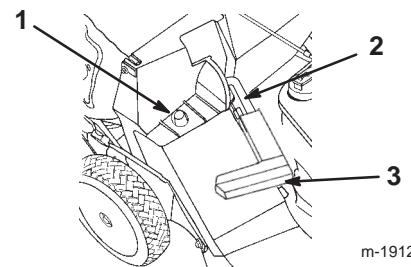

m-1912

Figure 17

1. Bag frame on retaining post
2. Pin engaged in catch
3. Handle fully forward and discharge door closed

3. Slide the hole in the bag frame onto the retaining post on the discharge tunnel (Fig. 17).
4. Set the rear of the bag frame onto the bag support rod.
5. Pull the discharge door handle forward until the pin clears the catch, and move the handle rearward until the pin locks in the bag notch (Fig. 18).

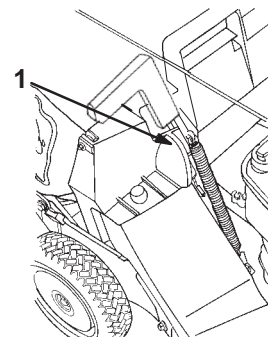

m-1913

Figure 18

1. Pin locked in bag notch

Note: The discharge door in the lawn mower housing is now open.

Mowing with the Grass Bag



Warning



A worn grass bag could allow small stones and other similar debris to be thrown in the operator's or bystander's direction and result in serious personal injury or death to the operator or bystanders.

Check the grass bag frequently. If it is damaged, install a new Toro replacement bag.

Cut the grass until the bag is full.

Important Do not overfill the bag.

Removing the Grass Bag



Danger



If the discharge door does not close completely, the lawn mower could throw objects, causing serious personal injury or death.

If you cannot close the door because the grass clippings clog the discharge area, stop the engine and gently move the discharge door handle back and forth until you can close the door completely. If you still cannot close the door, remove the obstruction with a stick, not your hand.



Danger



The lawn mower can throw grass clippings and other objects through an open discharge tunnel. Objects thrown with enough force could cause serious personal injury or death to the operator or bystander.

Never open the door on the discharge tunnel when the engine is running.

1. Stop the engine and wait for all moving parts to stop.
2. Raise the discharge door handle and move it forward to engage the pin with the catch (Fig. 17).
3. Grasp the handles at the front and the rear of the bag and lift the bag off the lawn mower.
4. Gradually tip the bag forward to empty the clippings.
5. To install the bag, refer to Installing the Grass Bag on page 13.

Operating Tips

- Review the safety instructions and read this manual carefully before operating the lawn mower.
- Clear the area of sticks, stones, wire, branches, and other debris that the blade could hit and throw.
- Keep everyone, especially children and pets, away from the area of operation.
- Avoid striking trees, walls, curbs, or other solid objects. Never deliberately mow over any object.
- If the lawn mower strikes an object or starts to vibrate, immediately stop the engine, disconnect the wire from the spark plug, and examine the lawn mower for damage.
- Maintain a **sharp blade** throughout the cutting season. Periodically file down nicks on the blade.
- Replace the blade when necessary with an original Toro replacement blade.
- Mow only dry grass or leaves. Wet grass and leaves tend to clump on the yard and can cause the lawn mower to plug or the engine to stall.



Warning



Wet grass or leaves can cause serious injury if you slip and contact the blade.

Mow only in dry conditions.

- Clean the underside of the lawn mower housing after each mowing. See Cleaning under the Housing on page 17.
- Keep the engine in good running condition.
- Set the engine speed to the fastest position for the best cutting results.



Warning



Operating a lawn mower with its engine running at a speed greater than the factory setting can cause the lawn mower to throw a part of the blade or engine into the operator's or bystander's area and result in serious personal injury or death.

- **Do not change the engine speed setting.**
- **If you suspect the engine speed is faster than normal, contact an Authorized Service Dealer.**

- Clean the air filter frequently. Mulching stirs up more clippings and dust which clogs the air filter and reduces engine performance.

Cutting Grass

- Grass grows at different rates at different times of the year. In the summer heat, it is best to cut grass at the 2-1/4-inch (5.7 cm), 2-3/4-inch (7.0 cm), or 3-1/4-inch (8.3 cm) cutting height settings. Cut only about a third of the grass blade at a time. Do not cut below the 2-1/4-inch (5.7 cm) setting unless the grass is sparse or it is late fall when grass growth begins to slow down.
- When cutting grass over six inches (15 cm) tall, first mow at the highest cutting height setting and walk slower; then mow again at a lower setting for the best lawn appearance. If the grass is too long and the leaves clump on top of the lawn, the lawn mower may plug and cause the engine to stall.
- Alternate the mowing direction. This helps disperse the clippings over the lawn for even fertilization.

If the finished lawn appearance is unsatisfactory, try one or more of the following:

- Sharpen the blade.
- Walk at a slower pace while mowing.
- Raise the cutting height on your lawn mower.
- Cut the grass more frequently.
- Overlap cutting swaths instead of cutting a full swath with each pass.
- Set the cutting height on the front wheels one notch lower than the rear wheels. For example, set the front wheels at 2-1/4 inches (5.7 cm) and the rear wheels at 2-3/4 inches (7.0 cm).

Cutting Leaves

- After cutting the lawn, ensure that half of the lawn shows through the cut leaf cover. You may need to make more than one pass over the leaves.
- For light leaf coverage, set all the wheels at the same cutting height setting.
- If there are more than five inches (12.7 cm) of leaves on the lawn, set the front cutting height one or two notches higher than the rear cutting height. This makes it easier to feed the leaves under the lawn mower housing.
- Slow down your mowing speed if the lawn mower does not cut the leaves finely enough.
- If you mow over oak leaves, you can add lime to the grass in the spring to reduce the acidity of the oak leaves.

Maintenance

Note: Determine the left and right sides of the machine from the normal operating position.

Recommended Maintenance Schedule

Maintenance Service Interval	Maintenance Procedure
Each Use	<ul style="list-style-type: none"> • Check the engine oil level. Refer to Checking the Engine Oil Level on page 17. • Check the stopping time of the blade brake. The blade must stop within 3 seconds of releasing the control bar; if it does not, contact an Authorized Service Dealer for repair. • Remove grass clippings and dirt from under the housing. Refer to Cleaning under the Housing on page 17. • Clean the discharge tunnel and the discharge tunnel plug. Refer to Cleaning the Discharge Tunnel and Plug on page 18. • Inspect the air cleaner elements. Refer to Servicing the Air Cleaner on page 18.
5 Hours	<ul style="list-style-type: none"> • Check the blade and the engine mounting fasteners. Tighten loose fasteners.
25 Hours	<ul style="list-style-type: none"> • Clean the air cleaner elements; clean them more frequently in dusty operating conditions. Refer to Servicing the Air Cleaner on page 18. • Lubricate the pivot arms. Refer to Lubricating the Pivot Arms on page 21.
50 Hours	<ul style="list-style-type: none"> • Change the engine oil.¹ Refer to Changing the Engine Oil on page 22. • Sharpen or replace the blade; maintain it more frequently if the edge dulls quickly in rough or in sandy conditions. Refer to Maintaining the Blade on page 19. • Clean the blade brake clutch shield. • Remove grass clippings and debris from under the belt cover. Refer to Cleaning under the Belt Cover on page 21. • Have an authorized engine servicing dealer check the flywheel brake operation.
75 Hours	<ul style="list-style-type: none"> • Adjust the self-propel drive system. Refer to Adjusting the Self-propel Drive on page 21.
100 Hours	<ul style="list-style-type: none"> • Inspect, clean, and adjust the spark plug; replace it if necessary. Refer to Servicing the Spark Plug on page 22. • Lubricate the gear case. Refer to Lubricating the Gear Case on page 23. • Adjust the blade brake cable. Refer to Adjusting the Blade Brake Cable on page 23. • Service the wheels. Refer to Servicing the Wheels on page 23. • Have an authorized engine servicing dealer check and adjust the flywheel brake pad.
250 Hours	<ul style="list-style-type: none"> • Replace the air cleaner elements; replace them more frequently in dusty operating conditions. Refer to Servicing the Air Cleaner on page 18. • Replace the spark plug. Refer to Servicing the Spark Plug on page 22. • Have an authorized engine servicing dealer check for leaks in the fuel system and/or a deteriorating fuel hose. Replace parts if necessary. • Have an authorized engine servicing dealer check and adjust the idle speed, check and adjust the valve clearance, and clean the fuel tank and filter.

¹Change the engine oil after the first 5 operating hours.

Important Refer to your engine owner's manual for additional maintenance procedures.



Caution



If you leave the wire on the spark plug, someone could accidentally start the engine and seriously injure you or other bystanders.

Disconnect the wire from the spark plug before you do any maintenance. Set the wire aside so that it does not accidentally contact the spark plug.

Checking the Engine Oil Level

Before you use the lawn mower, ensure that the oil level is between the lower limit and the upper limit marks as shown on the dipstick (Fig. 5). If the oil level is below the lower limit mark, add oil. Refer to Filling the Crankcase with Oil on page 8.

Checking the Blade Brake Clutch

Refer to Checking the Blade Brake Clutch on page 11.

Cleaning under the Housing

To ensure the best performance, keep the underside of the housing clean. Be especially careful to keep the kickers free of debris (Fig. 19).

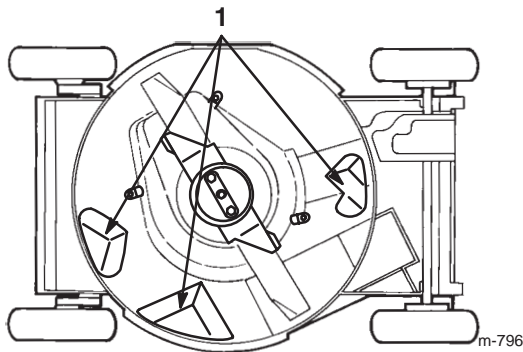

Figure 19

1. Kickers

Washing Method

1. Position the lawn mower on a flat concrete or asphalt surface near a garden hose.
2. Start the engine.

3. Hold the running water at handle level and direct the water to flow on the ground just in front of the **right rear tire** (Fig. 20).

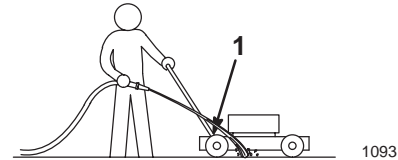

Figure 20

1. Rear right tire

Note: The water will splash into the blade and clean out the clippings. Let the water run until you no longer see clippings being washed out from under the housing.

4. Stop the engine and wait for all moving parts to stop.
5. Turn off the water.
6. Start the lawn mower again and let it run for a few minutes to dry out the lawn mower and its components.

Scraping Method

If the washing method does not remove all the debris from under the lawn mower, scrape it clean.

1. Disconnect the wire from the spark plug (Fig. 6).
2. Drain the fuel from the fuel tank.



Warning



Tipping the lawn mower may cause the fuel to leak from the carburetor or the fuel tank. Gasoline is extremely flammable, highly explosive, and, under certain conditions, can cause personal injury or property damage.

Avoid fuel spills by running the engine dry or by removing the gasoline with a hand pump; never siphon.

3. Tip the lawn mower onto its **left** side (air cleaner up) (Fig. 19).

4. Remove the dirt and grass clippings with a hardwood scraper. Avoid burrs and sharp edges.
5. Return the lawn mower to the operating position.
6. Fill the fuel tank with fresh gasoline.
7. Connect the wire to the spark plug.

Cleaning the Discharge Tunnel and Plug

Remove the plug from the discharge tunnel and clean it after each use.

Always ensure that the discharge tunnel door closes securely when you release the handle. If the debris prevents the discharge door from closing securely, clean the inside of the discharge tunnel and the door thoroughly.

Warning

Grass clippings and other objects can be thrown from an open discharge tunnel and cause serious injury or kill the operator or bystanders.

Never start or operate the lawn mower unless *one* of the following is true:

- **The discharge tunnel plug is locked securely in the discharge tunnel.**
- **The grass bag is locked in place.**
- **The optional side discharge chute is locked in place.**
- **The discharge tunnel door is locked in place.**

Servicing the Air Cleaner

Inspect the air cleaner elements after every time you use the lawn mower.

Clean the cover, base, and foam and paper elements after every 25 operating hours. Replace the elements after every 250 operating hours or sooner if they are damaged or excessively dirty.

Important Do not operate the engine without the air cleaner assembly; extreme engine damage will occur.

1. Stop the engine and wait for all moving parts to stop.
2. Disconnect the wire from the spark plug (Fig. 6).

3. Remove the 2 wing bolts that secure the cover (Fig. 21).

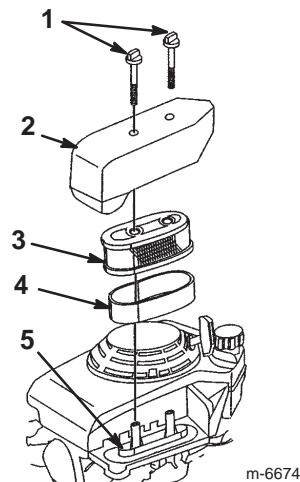

Figure 21

- | | |
|------------------|-----------------|
| 1. Wing bolts | 4. Foam element |
| 2. Cover | 5. Base |
| 3. Paper element | |

4. Remove the cover.

Note: Be careful to prevent dirt and debris from falling into the base.

5. Remove the foam and paper elements from the base (Fig. 21).
6. Remove the foam element from the paper element (Fig. 21).
7. Inspect the foam and paper elements, and replace them if they are damaged or excessively dirty.
8. Tap the paper element on a hard surface several times or use compressed air not exceeding 30 psi (207 kPa) through the filter from the wire screen side to remove any excess dirt. If the paper element is excessively dirty, replace it.

Note: Never try to brush dirt off the paper element; brushing forces the dirt into the fibers.
9. Clean the foam element in warm, soapy water or in a **nonflammable** solvent.

Note: Do not use gasoline to clean the foam element because it could create a risk of fire or explosion.
10. Rinse and dry the foam element thoroughly.
11. Dip the foam element in clean engine oil, then squeeze out the excess oil.

Note: Excess oil in the foam element restricts the air flow through the element and may reach the paper filter and clog it.

12. Wipe dirt from the base and the cover with a moist rag.

Note: Be careful to prevent dirt and debris from entering the air duct leading to the carburetor.

13. Install the air cleaner elements and ensure that they are properly positioned.

14. Securely install the cover with the 2 wing bolts.

Maintaining the Blade

Always mow with a sharp blade. A sharp blade cuts cleanly and without tearing or shredding the grass blades.

1. Stop the engine and wait for all moving parts to stop.
2. Disconnect the wire from the spark plug (Fig. 6).
3. Drain the gasoline from the fuel tank.
4. Tip the lawn mower onto its **left** side (air cleaner up) (Fig. 22).

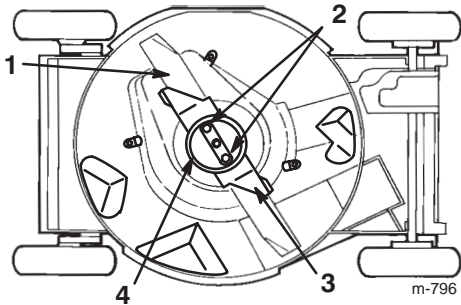
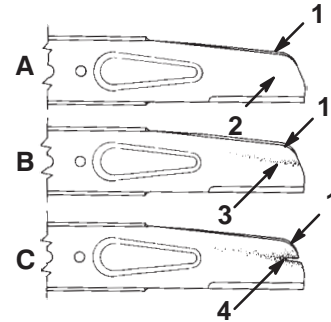

Figure 22

- | | |
|---------------|-------------------|
| 1. Blade | 3. Accelerator |
| 2. Blade nuts | 4. Anti-scalp cup |

Inspecting the Blade

Carefully examine the blade for sharpness and wear, especially where the flat and the curved parts meet (Fig. 23A). Because sand and abrasive material can wear away the metal that connects the flat and curved parts of the blade, check the blade before using the lawn mower. If you notice a slot or wear (Figs. 23B and 23C), replace the blade; refer to Removing the Blade on page 19.



270

Figure 23

- | | |
|-----------------------|----------------|
| 1. Sail | 3. Wear |
| 2. Flat part of blade | 4. Slot formed |

Note: For the best performance, install a new blade before the cutting season begins. During the year, file down any small nicks to maintain the cutting edge.



Danger



A worn or damaged blade can break, and a piece of the blade could be thrown into the operator's or bystander's area, resulting in serious personal injury or death.

- Inspect the blade periodically for wear or damage.
- Replace a worn or damaged blade.

Removing the Blade

1. Grasp the end of the blade using a rag or a thickly padded glove.
2. Remove the blade nuts, the anti-scalp cup, the accelerator, and the blade (Fig. 22).

Sharpening the Blade

File the top side of the blade to maintain its original cutting angle (Fig. 24A) and inner cutting edge radius (Fig. 24B). The blade will remain balanced if you remove the same amount of material from both cutting edges.

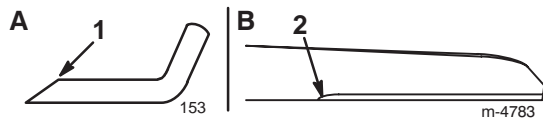

Figure 24

1. Sharpen at this angle only
2. Maintain the original radius here

Balancing the Blade

1. Check the balance of the blade by placing the center hole of the blade over a nail or screwdriver shank clamped horizontally in a vise (Fig. 25).

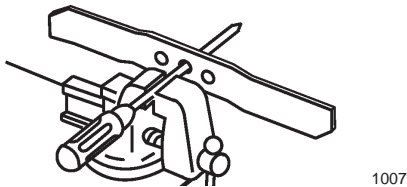

Figure 25

Note: You can also check the balance using a commercially manufactured blade balancer.

2. If either end of the blade rotates downward, file that end (not the cutting edge or the end near the cutting edge). The blade is properly balanced when neither end drops.

Installing the Blade

1. Install a sharp, balanced Toro blade, the accelerator, the anti-scalp cup, and the blade nuts. The sail of the blade must point toward the top of the lawn mower housing for proper installation. Torque the blade nuts to 15 to 27 ft-lb (20 to 37 N·m).



Warning



Operating the lawn mower without the accelerator in place can cause the blade to flex, bend, or break, resulting in serious injury or death to the operator or bystanders.

Do not operate the lawn mower without the accelerator.

2. Return the lawn mower to its upright position.

3. Connect the wire to the spark plug.

Cleaning the Blade Brake Clutch Shield

Clean the BBC (blade brake clutch) shield at the end of each mowing season to ensure the best performance and to prevent parts from degrading. Clean the BBC shield when you sharpen the blade because you need to remove the blade in order to remove the BBC shield.

1. Stop the engine and wait for all moving parts to stop.
2. Disconnect the wire from the spark plug (Fig. 6).
3. Drain the gasoline from the fuel tank.
4. Tip the lawn mower on its **right** side.



Warning



Tipping the lawn mower may cause the fuel to leak from the carburetor or the fuel tank. Gasoline is extremely flammable, highly explosive, and, under certain conditions, can cause personal injury or property damage.

Avoid fuel spills by emptying the fuel tank as directed; never siphon.

5. Remove 2 blade nuts, the anti-scalp cup, the accelerator, and the blade (Fig. 22).
6. Loosen the tabs that secure the BBC shield to the deck by loosening the nuts or the bolts on the tabs (Fig. 26). Rotate the tabs 180° to move them out of the way.

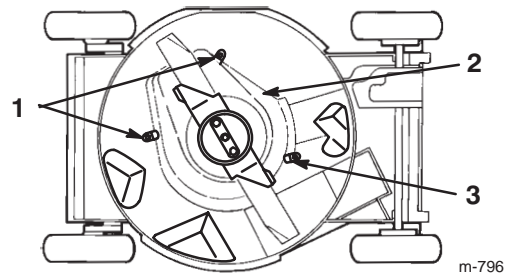

Figure 26

1. Tabs and nuts
2. BBC shield
3. Tab and bolt

7. Remove the BBC shield and brush or blow all the debris from under the shield and around the BBC system.
8. Install the BBC shield. Rotate the tabs 180° back into position. Tighten the nuts or the bolts on tabs to secure the BBC shield to the deck.

9. Install the blade, the accelerator, the anti-scalp cup, and the 2 blade nuts.
10. Turn the lawn mower upright.
11. Connect the wire to the spark plug.

Cleaning under the Belt Cover

Keep the area under the belt cover free of debris.

1. Stop the engine and wait for all moving parts to stop.
2. Disconnect the wire from the spark plug (Fig. 6).
3. Remove the bolts that secure the belt cover to the lawn mower housing (Fig. 27).

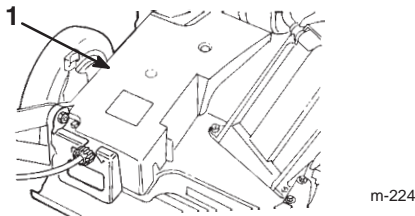

Figure 27

1. Belt cover

4. Lift off the cover and brush out all the debris around the belt area.
5. Install the belt cover.
6. Connect the wire to the spark plug.

Lubricating the Pivot Arms

After every 25 operating hours or when the season ends, lubricate the pivot arms.

1. Move the rear wheel cutting height levers to the center setting.
2. Wipe the grease fittings with a clean rag (Fig. 28).

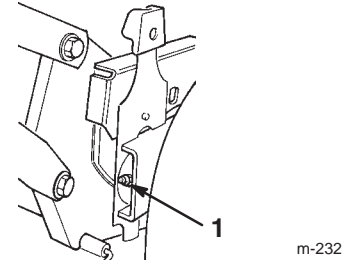

Figure 28

1. Grease fitting

3. Install a grease gun onto the fitting and gently apply two or three pumps of #2 multi-purpose lithium base grease (Fig. 28).

Note: Applying grease with excessive pressure may damage the seals.

Adjusting the Self-propel Drive

If the lawn mower does not self-propel or has a tendency to creep forward when the control bar is **more** than 1-1/2 inches (3.8 cm) from the handle, adjust the wheel drive control knob on the rear of the gear box (Fig. 29).

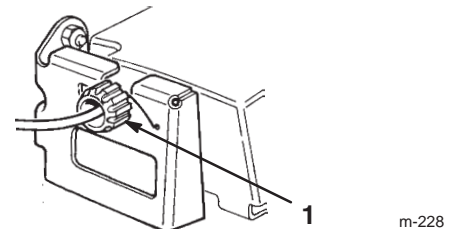

Figure 29

1. Control knob

1. Close the door in the lawn mower housing and remove the grass bag.
2. Rotate the control knob clockwise 1/2 turn if the lawn mower does not self-propel. If the lawn mower creeps forward, rotate the knob 1/2 turn counterclockwise (Fig. 29).

- Slowly pull the lawn mower rearward while you gradually move the control bar toward the handle.

Note: The adjustment is correct when the rear wheels stop turning and the control bar is about one inch (2.5 cm) from the handle (Fig. 30).

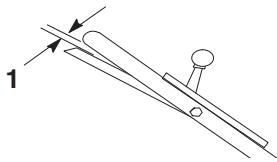

m-513a

Figure 30

- One inch (2.5 cm)

Changing the Engine Oil

Change the oil after the first 8 operating hours (or the first month); and then after every 100 operating hours (or every 6 months).

- Run the engine to warm the engine oil.

Note: Warm oil flows better and carries more contaminants.



Warning



Oil may be hot after engine has been run, and contact with hot oil can cause severe personal injury.

Avoid contacting the hot engine oil when you drain it.

- Stop the engine and wait for all moving parts to stop.
- Disconnect the wire from the spark plug (Fig. 6).
- Place a suitable drain pan under the dipstick/oil drain (Fig. 6).
- Clean around the dipstick.
- Remove the dipstick by rotating the cap counterclockwise and pulling it out.
- Raise the **left** side of the lawn mower to drain the oil from the dipstick fill tube into the drain pan.
- After draining the oil, return the lawn mower to the operating position.
- Fill the crankcase with fresh oil to the upper limit mark on the dipstick. Refer to the Filling the Crankcase with Oil on page 8.
- Insert the dipstick into the filler neck and rotate the cap clockwise until it is tight.
- Wipe up any spilled oil.

- Connect the wire to the spark plug.
- Recycle the used oil according to local codes.

Servicing the Spark Plug

Check the spark plug after every 100 operating hours or yearly; replace it after every 250 operating hours or every 2 years. Use an **NGK® BPR5ES** or **Nippondenso® W16EPR-U** spark plug or equivalent.

- Stop the engine and wait for all moving parts to stop.
- Disconnect the wire from the spark plug (Fig. 6).
- Clean around the spark plug.
- Remove the spark plug from the cylinder head.

Important Replace a cracked, fouled, or dirty spark plug. Do not clean the electrodes because grit entering the cylinder can damage the engine.

- Set the gap on the plug to 0.030 in. (0.76 mm) (Fig. 31).

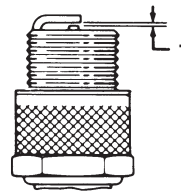

m-110

Figure 31

- 0.030 in. (0.76 mm)

- Carefully install the spark plug by hand (to avoid cross threading) until it is hand tight.
- Tighten the spark plug an additional 1/2 turn if it is new; otherwise, tighten it an additional 1/8 to 1/4 turn.

Important A loose spark plug can become very hot and can damage the engine; overtightening a spark plug may damage the threads in the cylinder head.

- Connect the wire to the spark plug.

Lubricating the Gear Case

After every 100 operating hours, grease the gear case.

1. Remove the grass bag.
2. Install a grease gun onto the fitting through the belt cover opening (Fig. 32).

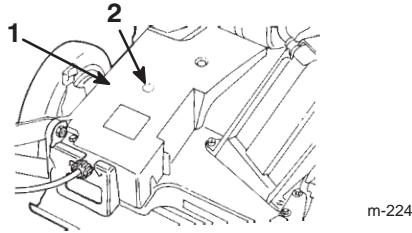

Figure 32

1. Belt cover
2. Grease fitting

3. Gently apply one to two pumps of #2 multi-purpose lithium-base grease.
4. Install the grass bag.

Adjusting the Blade Brake Cable

Whenever you install a new blade brake cable assembly or replace the belt, adjust the blade brake cable.

1. Stop the engine and wait for all moving parts to stop.
2. Disconnect the wire from the spark plug (Fig. 6).
3. Loosen the cable clamp screw until the brake cable conduit slides (Fig. 33).

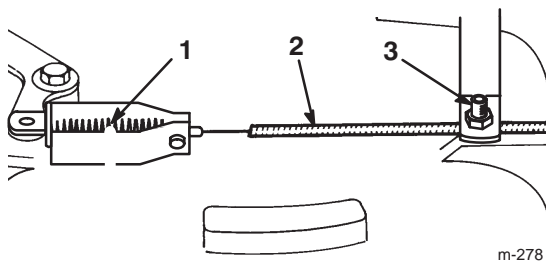

Figure 33

1. Spring
2. Cable conduit
3. Cable clamp screw

4. Pull the cable to the remove slack, but do not put tension on the spring. Tighten the cable clamp screw to lock the adjustment in place.



Warning



Do not overtighten the blade brake cable. Overtightening the blade brake cable could cause the blade brake to come off of the brake drum. If the brake does not contact the drum, the blade will not stop rotating when you release the control bar. A rotating blade could cause serious personal injury.

- Each time you adjust the brake cable, ensure that the brake stops the blade in 3 seconds or less.
- If the blade does not stop rotating in 3 seconds or less, bring the lawn mower to an Authorized Service Dealer for inspection and repair.

Servicing the Wheels

Removing the Wheels

1. Stop the engine and wait for all moving parts to stop.
2. Disconnect the wire from the spark plug (Fig. 6).
3. Remove the bolt, the wheel spacer, and the locknut mounting the wheel to the pivot arm (Fig. 34).

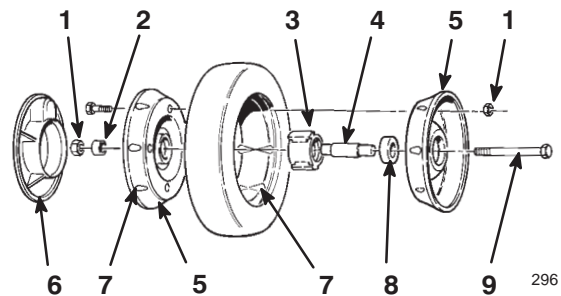

Figure 34

1. Locknut
2. Wheel spacer
3. Bearing/hub assembly
4. Bearing spacer
5. Wheel half
6. Plastic cover (rear wheels only)
7. Lug
8. Bearing (2)
9. Bolt

4. Separate the wheel halves from the tire by removing four bolts and four locknuts (Fig. 34).

Note: If you remove the bearings from the bearing/hub assembly, remove them by pressing on the bearing spacer (Fig. 34).

Assembling the Wheels

1. Position the tire onto one wheel half, aligning the lugs on each (Fig. 34).
2. Place the bearing/hub assembly into the center hole of the wheel half. Ensure that the legs of the hub are positioned over the flange of the hole (Fig. 34).
3. Place the other wheel half onto the bearing/hub assembly, aligning the wheel and the tire lugs and the mounting holes (Fig. 34).
4. Using two 1/4–20 x 1.50 in. fully threaded bolts and non-locking nuts, loosely secure the wheel halves together. Mount the bolts in the opposing holes (Fig. 34).
5. Check the alignment of all parts and tighten the bolts, alternating from side to side for a uniform fit, until the wheel halves are drawn together (Fig. 34).
6. Install the two bolts and two locknuts previously removed in the remaining holes in the wheel halves and tighten. Remove the two long bolts and replace them with two bolts and two locknuts (Fig. 34).
7. Install the wheel to the pivot arm with the bolts, a spacer, and a locknut. Ensure that the spacer is positioned between the wheel hub and the pivot arm (Fig. 34).

Storage

To prepare the lawn mower for off-season storage, perform the recommended maintenance procedures. Refer to Maintenance on page 16.

Store the lawn mower in a cool, clean, and dry place. Cover the lawn mower to keep it clean and protected.

Preparing the Fuel System

Empty the fuel tank when mowing the last time before storing the lawn mower.

1. Run the lawn mower until the engine stops from running out of fuel.
2. Prime the engine and start it again.
3. Allow the engine to run until it stops. When you can no longer start the engine, it is sufficiently dry.



Warning



Gasoline can vaporize if you store it over long periods of time and explode if it comes into contact with an open flame.

- **Do not store gasoline over long periods of time.**
- **Do not store the lawn mower with gasoline in the fuel tank or the carburetor in an enclosure with an open flame. (For example, a furnace or a water heater pilot light.)**
- **Allow the engine to cool before storing it in any enclosure.**

Preparing the Engine

1. While the engine is still warm, change the oil from the crankcase. Refer to Changing the Engine Oil on page 22.
2. Remove the spark plug (Fig. 6).
3. Using an oil can, add about one tablespoon of oil to the crankcase through the spark plug hole.
4. Slowly rotate the engine several times, using the starter rope, to distribute the oil.
5. Install the spark plug but **do not** connect the wire to the spark plug.

General Information

1. Clean the lawn mower housing. Refer to Cleaning under the Housing on page 17.
2. Clean any dirt and chaff from the cylinder, cylinder head fins, and blower housing.
3. Remove grass clippings, dirt, and grime from the external parts of the engine, the shrouding, and the top of the lawn mower housing.
4. Check the condition of the blade. Refer to Maintaining the Blade on page 19.
5. Clean the BBC shield; refer to Cleaning the Blade Brake Clutch Shield on page 20.
6. Service the air cleaner; refer to Servicing the Air Cleaner on page 18.
7. Lubricate the pivot arms; refer to Lubricating the Pivot Arms on page 21.
8. Tighten all nuts, bolts, and screws.
9. Touch up all rusted or chipped paint surfaces with paint available from an Authorized Service Dealer.

Removing the Lawn Mower from Storage

1. Check and tighten all fasteners.
2. Remove the spark plug and spin the engine rapidly using the starter to blow the excess oil from the cylinder.
3. Clean the spark plug or replace it if it is cracked, broken, or if the electrodes are worn.
4. Install the spark plug. Refer to Servicing the Spark Plug on page 22.
5. Perform any needed maintenance procedures; refer to Maintenance on page 16.

6. Fill the fuel in the fuel tank with fresh gasoline.
7. Check the engine oil level.
8. Connect the wire to the spark plug.

Accessories

You may purchase the following accessories from an Authorized Service Dealer:

- Side Discharge Kit
- Atomic Blade

Troubleshooting

Toro designed and built your lawn mower for trouble-free operation. Check the following components and items carefully, and refer to Maintenance on page 16 for more information. If a problem continues, contact an Authorized Service Dealer.

Problem	Possible Causes	Corrective Action
Engine does not start	<ol style="list-style-type: none"> 1. The fuel tank is empty or the fuel system contains stale fuel. 2. The throttle lever is not in the Choke position. 3. The wire is not connected to the spark plug. 4. The spark plug is pitted, fouled, or the gap is incorrect. 	<ol style="list-style-type: none"> 1. Drain and/or fill the fuel tank with fresh gasoline. If the problem persists, contact an Authorized Service Dealer. 2. Move the throttle lever to the Choke position. 3. Connect the wire to the spark plug. 4. Check the spark plug and adjust the gap if necessary. Replace the spark plug if it is pitted, fouled, or cracked.
Engine starts hard or loses power	<ol style="list-style-type: none"> 1. The fuel tank contains stale fuel. 2. The fuel cap vent hole is plugged. 3. The air cleaner elements are dirty and are restricting the air flow. 4. The underside of the lawn mower housing contains clippings and debris. 5. The spark plug is pitted, fouled, or the gap is incorrect. 6. The engine oil level is low or the oil is dirty. 	<ol style="list-style-type: none"> 1. Drain and fill the fuel tank with fresh gasoline. 2. Clean the fuel cap vent hole or replace the fuel cap. 3. Service the air cleaner elements. 4. Clean under the lawn mower housing. 5. Check the spark plug and adjust the gap if necessary. Replace the spark plug if it is pitted, fouled, or cracked. 6. Check the engine oil. Change the oil if it is dirty or add oil if it is low.

Problem	Possible Causes	Corrective Action
Engine runs rough	<ol style="list-style-type: none"> 1. The wire is not connected to the spark plug. 2. The spark plug is pitted, fouled, or the gap is incorrect. 3. The throttle lever is not in the Fast position. 4. The air cleaner elements are dirty and are restricting the air flow. 	<ol style="list-style-type: none"> 1. Connect the wire to the spark plug. 2. Check the spark plug and adjust the gap if necessary. Replace the spark plug if it is pitted, fouled, or cracked. 3. Move the throttle lever to the Fast position. 4. Service the air cleaner elements.
Lawn mower or engine vibrates excessively	<ol style="list-style-type: none"> 1. The blade is bent or is out of balance. 2. The blade mounting nuts are loose. 3. The underside of the lawn mower housing contains clippings and debris. 4. The engine mounting bolts are loose. 	<ol style="list-style-type: none"> 1. Balance the blade. If the blade is bent, replace it. 2. Tighten the blade mounting nuts. 3. Clean under the lawn mower housing. 4. Tighten the engine mounting bolts.
Uneven cutting pattern	<ol style="list-style-type: none"> 1. All four wheels are not at the same height. 2. The blade is dull. 3. You are mowing in the same pattern repeatedly. 4. The underside of the lawn mower housing contains clippings and debris. 	<ol style="list-style-type: none"> 1. Place all four wheels at the same height. 2. Sharpen and balance the blade. 3. Change the mowing pattern. 4. Clean under the lawn mower housing.
Discharge chute plugs	<ol style="list-style-type: none"> 1. The throttle lever is not in the Fast position. 2. The cutting height is too low. 3. You are mowing too fast. 4. The grass is wet. 5. The underside of the lawn mower housing contains clippings and debris. 	<ol style="list-style-type: none"> 1. Move the throttle lever to the Fast position. 2. Raise the cutting height. 3. Slow down. 4. Allow the grass to dry before mowing. 5. Clean under the lawn mower housing.
Lawn mower does not self-propel	<ol style="list-style-type: none"> 1. The self-propel drive cable is out of adjustment or is damaged. 2. There is debris under the belt cover. 	<ol style="list-style-type: none"> 1. Adjust the self-propel drive cable. Replace the cable if necessary. 2. Clean the debris from under the belt cover.



Gas, Cordless,
Electric, and 21"
Commercial Duty
Walk Mowers

The Toro Total Coverage Guarantee

A Full Warranty

(Limited Warranty for Commercial Use)

Conditions and Products Covered

The Toro Company and its affiliate, Toro Warranty Company, pursuant to an agreement between them, jointly promise to repair any Toro Product used for normal residential purposes* if defective in materials or workmanship or if it stops functioning due to the failure of a component. The following time periods apply from the date of purchase:

<u>Products</u>	<u>Warranty Period</u>
• Super Recycler® Walk Mowers	5 year full warranty
• VacuPower® Walk Mowers	5 year full warranty
• All Other Mowers	2 year full warranty
• All Batteries	1 year full warranty

This warranty includes the cost of parts and labor, but you must pay transportation costs.

This warranty applies to all gas, cordless, and electric consumer walk power mowers.

* Normal residential purposes means use of the product on the same lot as your home. Use at more than one location is considered commercial use, and the commercial use warranty would apply.

Limited Warranty for Commercial Use

Toro Walk Power Mowers used for commercial, institutional, or rental use are warranted against defects in materials or workmanship. Components failing due to normal wear are not covered by this warranty. The following time periods apply from the date of purchase:

<u>Products</u>	<u>Warranty Period</u>	
	<u>Engine</u>	<u>Entire Unit</u>
• 21" Commercial Duty Walk Mowers	2 year limited	1 year limited
• All Other Mowers	45 day limited	45 day limited

Instructions for Obtaining Warranty Service

Should you feel your Toro Product contains a defect in materials or workmanship, contact the dealer who sold you the product or any Authorized Service Dealer or Master Service Dealer. The Yellow Pages of your telephone directory is a good reference source. The dealer will either arrange service at his/her dealership or recommend another Authorized Service Dealer who may be more convenient. You may need proof of purchase (copy of registration card, sales receipt, etc.) for warranty validation.

If for any reason you are dissatisfied with the Service Dealer's analysis of the defect in materials or workmanship or if you need a referral to a Toro Service Dealer, please feel free to contact us at:

Customer Service Department
Toro Warranty Company
8111 Lyndale Avenue South
Bloomington, MN 55420-1196
952-888-8801 or 800-421-9684

Countries Other than the United States or Canada

Customers who have purchased Toro products exported from the United States or Canada should contact their Toro Distributor (Dealer) to obtain guarantee policies for your country, province, or state. If for any reason you are dissatisfied with your Distributor's service or have difficulty obtaining guarantee information, contact the Toro importer. If all other remedies fail, you may contact us at Toro Warranty Company.

Owner Responsibilities

You must maintain your Toro Product by following the maintenance procedures described in the operator's manual. Such routine maintenance, whether performed by a dealer or by you, is at your expense.

Items and Conditions Not Covered

There is no other express warranty except for special emission system coverage on some products and the Toro Starting Guarantee on GTS Engine. This express warranty does not cover:

- Cost of regular maintenance service or parts, such as filters, fuel, lubricants, oil changes, spark plugs, blade sharpening, worn blade, cable/linkage adjustments, or brake and clutch adjustments.
- Any product or part which has been altered or misused or required replacement or repair due to accidents or lack of proper maintenance.
- Repairs necessary due to improper fuel, contaminants in the fuel system, or failure to properly prepare the fuel system prior to any period of non-use over three months.
- Repairs necessary due to improper battery care, electrical supply irregularities, or failure to properly prepare the mower prior to any period of non-use.
- Pickup and delivery charges.

All repairs covered by this warranty must be performed by an Authorized Toro Service Dealer using Toro approved replacement parts.

General Conditions

Repair by an Authorized Toro Service Dealer is your sole remedy under this warranty.

Neither The Toro Company nor Toro Warranty Company is liable for indirect, incidental or consequential damages in connection with the use of the Toro Products covered by this warranty, including any cost or expense of providing substitute equipment or service during reasonable periods of malfunction or non-use pending completion of repairs under this warranty. Some states do not allow exclusions of incidental or consequential damages, or limitations on how long an implied warranty lasts, so the above exclusions and limitations may not apply to you.

This warranty gives you specific legal rights, and you may also have other rights which vary from state to state.