



66" Rake-O-Vac Sweeper

Model No. 07050-220000001 and up

Operator's Manual



Warning



CALIFORNIA

Proposition 65 Warning

The engine exhaust from this product contains chemicals known to the State of California to cause cancer, birth defects, or other reproductive harm.

Important The engine in this product is not equipped with a spark arrester muffler. It is a violation of California Public Resource Code Section 4442 to use or operate this engine on any forest-covered, brush-covered, or grass-covered land as defined in CPRC 4126. Other states or federal areas may have similar laws.

This spark ignition system complies with Canadian ICES-002.

Ce système d'allumage par étincelle de véhicule est conforme à la norme NMB-002 du Canada.

Contents

	Page
Contents	2
Introduction	3
Safety	3
Safety and Instruction Decals	5
Specifications	7
Dimensions and Weights (approx.)	7
Optional Equipment	7
Setup	8
Remove, Activate And Charge Battery	8
Install Battery	8
Mount Sweeper To Prime Mover	9
Removing Sweeper From Prime Mover	9

	Page
Before Operating	10
Check Engine Oil	10
Fill Fuel Tank	10
Check Tire Pressure	11
Transport Hooks	11
Adjust Reel Support Arm	11
Adjust Rake Depth	12
Adjust Rubber Flap	12
Operation	13
Controls	13
Starting Instructions	14
Stopping Instructions	14
Operating Tips	14
Inspection And Cleanup After Operation	14
Maintenance	15
Lubrication	15
Oil Sweeper Jack	15
Changing Engine Oil and Filter	16
General Air Cleaner Maintenance	16
Servicing Air Cleaner	16
Replacing Spark Plugs	17
Removing Debris From Engine	17
Replace Fuel Filter	17
Changing Rubber Flap	17
Cleaning Blower Housing	18
Adjusting Belts	18
Pulley Removal	20
Flex Tip Reel Removal	20
Thatcher Installation	20
Flex Tip Rake Rod Or Finger Plate Replacement	21
Flex Tip Rake Tine Replacement	22
Brush Half Replacement	22
Changing Tires	23
Battery Care	23
The Toro General Commercial Products Warranty ..	24

Introduction

Read this manual carefully to learn how to operate and maintain your product properly. The information in this manual can help you and others avoid injury and product damage. Although Toro designs and produces safe products, you are responsible for operating the product properly and safely.

Whenever you need service, genuine Toro parts, or additional information, contact an Authorized Service Dealer or Toro Customer Service and have the model and serial numbers of your product ready. Figure 1 illustrates the location of the model and serial numbers on the product.

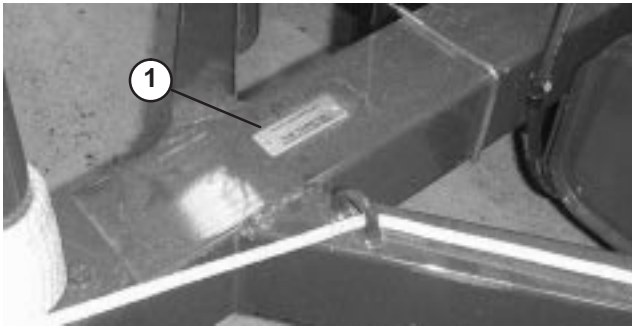

Figure 1

1. Model & serial number plate

Write the product model and serial numbers in the space below:

Model No. _____
Serial No. _____

This manual identifies potential hazards and has special safety messages that help you and others avoid personal injury and even death. **Danger**, **Warning**, and **Caution** are signal words used to identify the level of hazard. However, regardless of the hazard, be extremely careful.

Danger signals an extreme hazard that *will* cause serious injury or death if you do not follow the recommended precautions.

Warning signals a hazard that *may* cause serious injury or death if you do not follow the recommended precautions.

Caution signals a hazard that may cause minor or moderate injury if you do not follow the recommended precautions.

This manual uses two other words to highlight information.

Important calls attention to special mechanical information and **Note:** emphasizes general information worthy of special attention.

Safety

The RAKE-O-VAC was designed and tested to offer safe service when operated and maintained properly. Although hazard control and accident prevention partially are dependent upon the design and configuration of the machine, these factors are also dependent upon the awareness, concern, and proper training of the personnel involved in the operation, transport, maintenance, and storage of the machine. Improper use or maintenance of the machine can result in injury or death. To reduce the potential for injury or death, comply with the following safety instructions.

Since the Rake-O-Vac must be towed to operate, it is extremely important that the tow tractor be carefully selected to assure the best performance and safe operation.

The tow tractor must have the proper wheel base and tread width and equipped with a roll bar and seat belt to operate safely on hilly terrain. The normal operating speed is 6 mph but will vary with terrain and debris being picked up. The maximum transport speed is 20 mph with slower speeds required on hilly terrain. Refer to tractor Operator's Manual for information or tractor service agency if you have any question on safe operation.

The brakes of the tow tractor must have the capacity to stop the Rake-O-Vac with hopper fully loaded and traveling at the maximum recommended transport speed.

The Rake-O-Vac must comply with local road requirements, if transported on public roads. A Slow-moving vehicle sign has been provided. Signal lights and brakes are not provided and may be required in some areas.

Before Operating

- Operate the machine only after reading and understanding the contents of this manual. A replacement manual is available by sending complete model and serial number to:
The Toro Company
8111 Lyndale Avenue South
Bloomington, Minnesota 55420-1196.
- Never allow children to operate the machine or adults to operate it without proper instructions.
- Become familiar with the controls and know how to stop the engine/sweeper quickly.

- Keep all shields, safety devices and decals in place. If a shield, safety device or decal is malfunctioning, illegible, or damaged, repair or replace it before operating the machine.
- Always wear substantial shoes. Do not operate machine while wearing sandals, tennis shoes or sneakers. Do not wear loose fitting clothing which could get caught in moving parts and cause personal injury.
- Wearing safety glasses, safety shoes, long pants and a helmet is advisable and required by some local safety and insurance regulations.
- Keep everyone, especially children and pets away from the areas of operation.
- Since gasoline is highly flammable, handle it carefully.
 - Use an approved gasoline container.
 - Do not remove cap from fuel tank when engine is hot or running.
 - Do not smoke while handling gasoline.
 - Fill fuel tank outdoors and to about one inch below top of tank, (bottom of filler neck). Do not overfill.
 - Wipe up any spilled gasoline.
- Before leaving operator position:
 - Shift into neutral, stop prime mover and engage parking brake.
 - Shut engine off and wait for all movement to stop. The impeller may momentarily turn after other components have stopped. Use extreme caution when removing cover from blower housing.
 - Disengage and lower sweeper implement.
 - Shut sweeper engine off.
 - Take precautions to prevent accidental starts, rolling away, etc.
- If prime mover or sweeper ever vibrate abnormally, stop immediately, turn engine off, wait for all motion to stop and inspect for damage. Repair all damage before commencing operation.
- Whenever machine is left unattended, be sure engine is stopped, implement is lowered and key is removed from ignition switch.
- Shut sweeper blower off when dumping contents of hopper. Always stand to extreme right or left side of hopper when opening tailgate.
- Park on a level surface, empty hopper and block wheels before removing sweeper from prime mover.

While Operating

- Exhaust fumes are hazardous and could be deadly, so do not run the engine in a confined area without adequate ventilation.
- This product may exceed noise levels of 85 dB(A) at the operator position. Ear protectors are recommended, for prolonged exposure, to reduce the potential of permanent hearing damage.
- Never carry passengers on prime mover or allow anyone to ride on sweeper.
- Disengage clutch before starting sweeper engine.
- Using the machine demands attention. To prevent tipping or loss of control:
 - Use extreme caution around ditches, creeks or other hazards.
 - Watch for holes or other hidden hazards.
 - Use caution when operating machine on a steep slope. Reduce speed when making sharp turns or when turning on hillsides.
 - Avoid sudden stops and starts.
 - Before backing up, look to the rear and assure no one is behind the machine.
 - Watch out for traffic when near or crossing roads. Always yield the right of way.

Maintenance

- Disengage power to sweeper implement and stop engine before servicing or making adjustments.
- Disengage power to sweeper implement and stop engine when transporting or not in use.
- To make sure entire machine is in good condition, keep all nuts, bolts and screws properly tightened.
- If major repairs are ever needed or assistance is required, contact an Authorized TORO Distributor.
- To reduce potential fire hazard, keep the engine area free of excessive grease, grass, leaves and accumulation of dirt.
- If the engine must be running to perform a maintenance adjustment, keep hands, feet, clothing, and any parts of the body away from the engine and any moving parts. Keep everyone away.
- Do not overspeed engine by changing governor settings. To assure safety and accuracy, have an Authorized Toro Distributor check maximum engine speed with a tachometer.
- Engine must be shut off before checking oil or adding oil to the crankcase.

- Check prime mover brakes periodically to be sure brakes, when applied, will hold firmly. Also, check to make sure all safety equipment is functioning properly.

- To be sure of optimum performance and safety, always purchase genuine TORO replacement parts and accessories. Replacement parts and accessories made by other manufacturers could be dangerous. Such use could void the product warranty of The Toro Company.

Safety and Instruction Decals



Safety decals and instructions are easily visible to the operator and are located near any area of potential danger. Replace any decal that is damaged or lost.



67-5360



13-7430

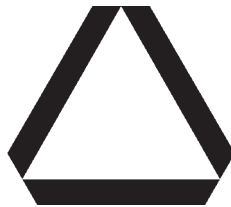

13-2930

1. Slow moving vehicle



13-6760



13-6410



61-5950



53-4420



93-7307

⚠ WARNING



92-8309

- ROTATING PULLEYS AND CHAINS CAN CAUSE SERIOUS INJURY
- ALWAYS STOP ENGINE BEFORE RAISING COVER TO SERVICE
- KEEP ALL SHIELDS IN PLACE
- MAKE SURE ALL MOVEMENT HAS STOPPED BEFORE SERVICING OR UNCLOGGING MACHINE
- KEEP BYSTANDERS AWAY WHILE STARTING AND MOVING MACHINE
- KEEP HANDS, FEET, AND CLOTHING AWAY FROM ALL POWER DRIVEN PARTS

92-8309

OPERATING INSTRUCTIONS

1. INFLATE TIRES TO CORRECT PRESSURE.
TIRE SIZE: 11L - 14 SL 28 PSI
2. ADJUST HITCH TO TOW TRACTOR SO THAT FRAME IS PARALLEL WITH GROUND WHEN RAKE-O-VAC IS ON A FLAT SURFACE.
3. FOR FLEX-TIP-REEL OR STREET BROOM, ADJUST COUNTER BALANCE SPRINGS TO PROVIDE 30-35 POUNDS EACH END, FOR PROPER FLOATATION.
4. ADJUST GAGE WHEELS ON EACH SIDE SO FLEX-TIP-REEL FINGERS CONTACT TURF VERY LIGHTLY WITHOUT BENDING BACK AND STREET BROOM CONTACTS GROUND SURFACE WITH APPROXIMATELY 1" OF SWEEPING CONTACT WIDTH. HEAVIER CONTACT DECREASES PERFORMANCE.
5. THE RUBBER FLAP SHOULD BE IN DOWN POSITION FOR MOST USAGE. MAY BE RAISED FOR LARGE VOLUMES OF DRY TREE LEAVES.
6. ALWAYS DUMP DEBRIS FROM HOPPER BEFORE REMOVING RAKE-O-VAC FROM TOW VEHICLE.
7. BLOCK WHEELS WHEN DISCONNECTED FROM TOW VEHICLE AND PARK UNIT ON FLAT SURFACE.
8. IF BLOWER HOUSING BECOMES BLOCKED WITH DEBRIS, STOP UNIT AND WAIT FOR IMPELLER TO COME TO A COMPLETE STOP BEFORE ATTEMPTING TO CLEAR DEBRIS.
9. SEE OPERATOR'S MANUAL FOR ADDITIONAL OPERATING INSTRUCTIONS.

93-4041

93-4041

Specifications

Note: Specifications and design are subject to change without notice.

Machine Drive	(Model 07050): Kohler, 4 cycle air cooled 22 H.P. engine @ 3600 rpm, 41.1 cu. in. (674 cc) displacement. Oil capacity is 4 pints w/filter. Mechanical fuel pump. Gas tank capacity is 4 gallons.
Frame	All welded structural rectangular 11 ga. tubing.
Hitch	Pin-type, 3/4" dia. vertically adjustable in 1" increments.
Fan	Centrifugal type—double inlet; 4 blade, 16" wide, 23–14" diameter, 3/16" thick, high tensile steel. Shaft mounted in self-aligning, sealed ball bearings. Blower inlet area is 286 sq. in., blower discharge area is 255 sq. in. Twin fan hood construction for uniform air distribution: 4–1/2" deep x 63" wide (inlet area—283 sq. in.); variable position from weighted rubber flap.
Fan Drive	Banded double drive belt direct from drive shaft to fan impeller drive shaft with driver pulley, fan with driven pulley. Fan impeller runs at 1580 R.P.M. (tip speed 9100 ft./min.) at 3250 engine R.P.M.
Hopper	5–3/4 cu. yd. volume; 18 gauge top section with 16 gauge bottom section—rib reinforced; full width self cleaning semi-automatic dumping.
Flex Tip Reel	Forward spinning with 6 rows of teeth. All steel construction with replaceable nylon teeth; each row containing 11 individually spring-loaded flexible sets, 552 teeth total; shaft set in self-aligning sealed bearings. Reel supported by adjustable counter balance springs and adjustable gauge wheels. Gauge wheels are steel construction with non-scuffing rubber tires and sealed ball bearings; infinitely adjustable vertically.
Flex Tip Reel Drive	Banded double drive belt from engine pulley to jackshaft pulley; belt from jack shaft (driver) pulley to flex tip reel (driven) pulley. Flex tip runs at 275 R.P.M. (tip speed 1355 ft./min.) at 3250 engine R.P.M.

Dimensions and Weights (approx.)

Width	85–1/2"
Height	79–1/2"
Length	13' 3"
Empty Weight	2160 lb. (Model 07050)

Optional Equipment

Hard Surface Brush Kit	Model No. 07162
Thatching Reel Kit	Model No. 07178
Flex Tip Reel	Model No. 07164
Spark Arrester Muffler*	Kohler No 1218902

* Contact Your Local Kohler Dealer

Setup

Note: Determine the left and right side of the machine from the normal operating position.

Description	Qty.	Use
Operator's Manual	1	Read before operating the machine.
Engine Operator's Manual	1	
Parts Catalog	1	
Registration Card	1	Fill out and return to Toro.

Remove, Activate And Charge Battery

- If Battery is not filled with electrolyte or activated, bulk electrolyte with 1.260 specific gravity must be purchased from a local battery supply outlet and added to battery.

Danger

Battery electrolyte contains sulfuric acid which is a deadly poison and causes severe burns.

- Do not drink electrolyte and avoid contact with skin, eyes or clothing. Wear safety glasses to shield your eyes and rubber gloves to protect your hands.**
- Fill the battery where clean water is always available for flushing the skin.**

Warning

CALIFORNIA
Proposition 65 Warning

Battery posts, terminals, and related accessories contain lead and lead compounds, chemicals known to the State of California to cause cancer and reproductive harm. *Wash hands after handling.*

- Unhook springs from battery cover, remove cover and lift battery out of battery box.
- Remove filler caps from battery and slowly fill each cell until electrolyte is up to fill line.
- Replace filler caps and connect a 3 to 4 amp battery charger to the battery posts. Charge the battery at a rate of 3 to 4 amperes for 4 to 8 hours.

Warning

Charging the battery produces gasses that can explode.

Never smoke near the battery and keep sparks and flames away from battery.

- Remove filler caps and slowly add electrolyte to each cell until level is up fill line. Install filler caps.

Important Do not overfill battery. Electrolyte will overflow onto other parts of the machine and severe corrosion and deterioration will result.

- When battery is charged, disconnect charger from electrical outlet and battery posts. Allow battery to sit for 5 to 10 minutes before proceeding to next step.

Install Battery

- Slide the battery into battery box with the terminals to the inside.

Warning

Battery terminals or metal tools could short against metal tractor components causing sparks. Sparks can cause the battery gasses to explode, resulting in personal injury.

- When removing or installing the battery, do not allow the battery terminals to touch any metal parts of the tractor.**
- Do not allow metal tools to short between the battery terminals and metal parts of the tractor.**

- Attach the negative cable (wire from engine block) to the negative (-) terminal of the battery.



Warning



Incorrect battery cable routing could damage the tractor and cables causing sparks. Sparks can cause the battery gasses to explode, resulting in personal injury.

- Always *disconnect* the negative (black) battery cable before disconnecting the positive (red) cable.
- Always *connect* the positive (red) battery cable before connecting the negative (black) cable.

3. Attach the positive cable (wire from ignition switch) to the positive (+) terminal.
4. Coat the terminals and mounting fasteners with petroleum jelly to prevent corrosion.
5. Install battery cover and secure with springs.

Mount Sweeper To Prime Mover

To assure proper debris pickup, make sure sweeper frame is parallel with the ground.

1. Position sweeper on a flat, level surface.
2. Insert sweeper jack caster wheel onto sweeper end of jack tube.
3. Adjust sweeper jack so distance from top of frame to ground is approximately 23-1/2" (Fig. 2).
4. Back prime mover up to sweeper.
5. Adjust sweeper hitch tongue to same level as hitch of prime mover as follows:
 - Remove capscrews and locknuts securing hitch tongue to frame (Fig. 2).
 - Raise or lower hitch tongue to position approximately level with prime move hitch and secure with (2) capscrews and locknuts.

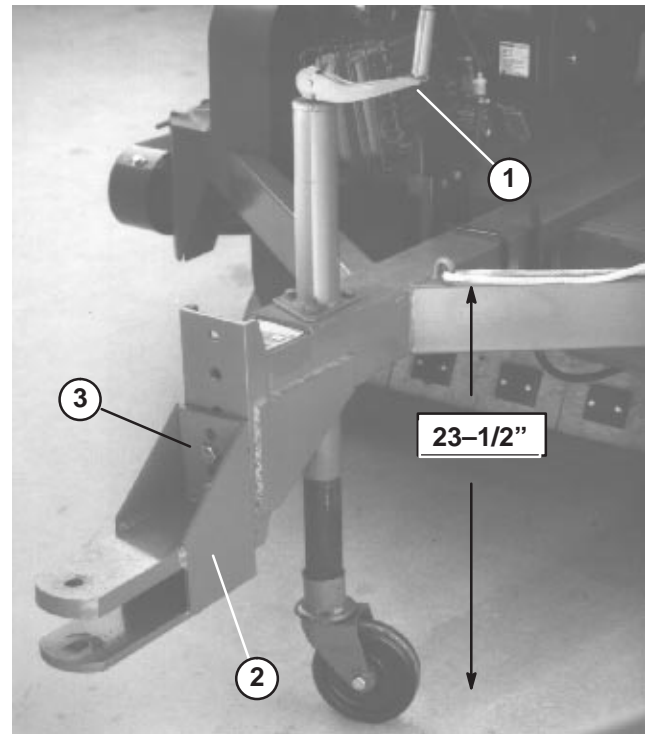

Figure 2

- | | |
|-------------------------------|---------------------|
| 1. Sweeper jack | 3. Adjusting screws |
| 2. Hitch tongue (Model 07050) | |

Removing Sweeper From Prime Mover



Warning



Always empty sweeper hopper before disconnecting hopper from prime mover or sweeper may tip backwards and cause injury.

1. Park sweeper on a level surface and block wheels.
2. Insert castor wheel onto jack tube.
3. Raise sweeper jack handle and lower caster wheel to ground.
4. Continue to raise sweeper with jack until hair pin cotter and hitch pin can be removed from hitch.

Before Operating

Check Engine Oil

The engine is shipped with approximately 2 quarts (w/filter) of oil in the crankcase; however, level of oil must be checked before and after the engine is first started.

1. Position machine on a level surface.
2. Remove dipstick and wipe it with a clean rag. Insert dipstick into tube and make sure it is seated fully. Remove dipstick from tube and check level of oil. If oil level is low, remove filler cap and add enough oil to raise level to “FULL” mark on dipstick.



Figure 3

1. Dipstick

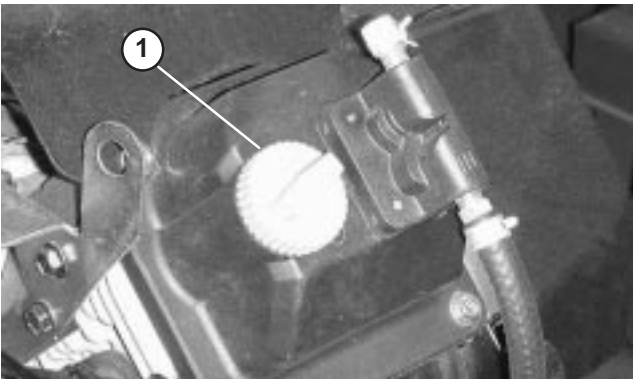

Figure 4

1. Filler cap

3. The engine uses any high-quality detergent oil having the American Petroleum Institute -API- “service classification” SG, SH or SJ. Oil viscosity (weight) is selected according to the anticipated ambient temperature.

Temperature / viscosity recommendations are:

- Above 0°F (-20°C) – Use 10W-30 or 10W-40.
- Below 32°F (0°C) – Use 5W-20 or 5W-30.

4. Pour oil into fill opening until the oil level is up to the “FULL” mark on the dipstick. Add the oil slowly and check the level often during this process. DO NOT OVERFILL

Important Check level of oil every 8 operating hours or daily. Initially, change oil after the first 5 hours of operation; thereafter, under normal conditions, change oil every 100 hours and filter every 200 hours. However, change oil more frequently when engine is operated in extremely dusty or dirty conditions.

5. Install the dipstick firmly in place.

Fill Fuel Tank

Fuel tank capacity is approximately 4 gallons.



Danger



In certain conditions, gasoline is extremely flammable and highly explosive. A fire or explosion from gasoline can burn you and others and can damage property.

- Fill the fuel tank outdoors, in an open area, when the engine is cold. Wipe up any gasoline that spills.
- Do not fill the fuel tank completely full. Add gasoline to the fuel tank until the level is 1 in. (25 mm) below the bottom of the filler neck. This empty space in the tank allows gasoline to expand.
- Never smoke when handling gasoline, and stay away from an open flame or where gasoline fumes may be ignited by a spark.
- Store gasoline in an approved container and keep it out of the reach of children. Never buy more than a 30-day supply of gasoline.
- Always place gasoline containers on the ground away from your vehicle before filling.
- Do not fill gasoline containers inside a vehicle or on a truck or trailer bed because interior carpets or plastic truck bed liners may insulate the container and slow the loss of any static charge.
- When practical, remove gas-powered equipment from the truck or trailer and refuel the equipment with its wheels on the ground.
- If this is not possible, then refuel such equipment on a truck or trailer from a portable container, rather than from a gasoline dispenser nozzle.
- If a gasoline dispenser nozzle must be used, keep the nozzle in contact with the rim of the fuel tank or container opening at all times until fueling is complete.

Use **unleaded** regular gasoline suitable for automotive use (85 pump octane minimum). Leaded regular gasoline may be used if unleaded regular is not available.

Important Never use methanol, gasoline containing methanol, or gasohol containing more than 10% ethanol because the fuel system could be damaged. Do not mix oil with gasoline.

1. Clean area around fuel tank cap.
2. Remove fuel tank cap.
3. Fill tank to about one inch below top of tank, (bottom of filler neck). **DO NOT OVERFILL**. Then install cap.
4. Wipe up any fuel that may have spilled to prevent a fire hazard.

Check Tire Pressure

Check tire pressure daily to assure proper level.

Correct tire pressure is 28 psi.

Transport Hooks

1. Lift each end of reel and remove transport hooks before operating machine.

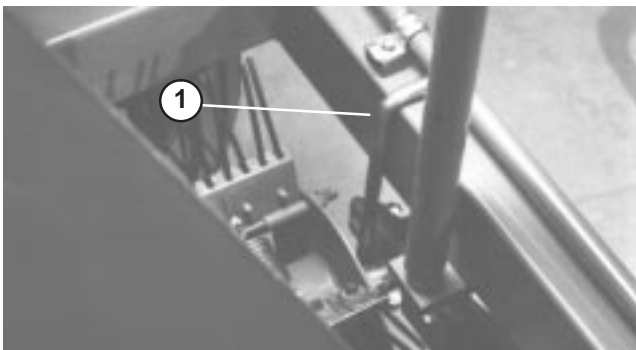

Figure 5

1. Transport hook
2. When transporting sweeper from one location to another, support flex tip reel, broom or thatching reel with transport hooks.

Adjust Reel Support Arm

When machine is operated, gauge wheel should ride over the turf evenly. If reel support arm has a tendency to bounce, spring setting is too tight. If gauge wheel scars turf, spring setting is too light.

To adjust reel support arm:

1. Pull rake lever rearward to lower flex tip reel or broom.

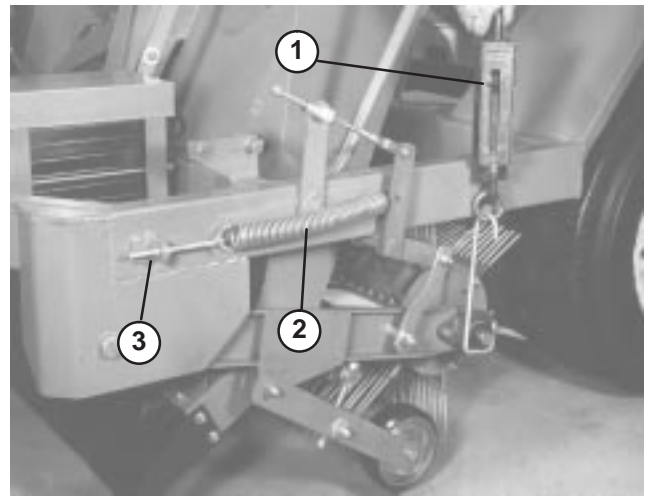

Figure 6

1. Spring scale
 2. Counterbalance spring
 3. Adjustment screw
2. Position a spring scale on transport hook and lift up. Tension necessary to lift gauge wheel off ground should be 30–50 lbs.
 3. If tension is not 30–50 lbs., adjustment is made by tightening or loosening adjustment screw on counterbalance spring.
 4. Perform this procedure on both sides of sweeper.
- Note:** Because of added weight of drive components, the R.H. spring will require a tighter setting than the L.H. spring.

Adjust Rake Depth

Flex tip reel should be adjusted so rake tips slightly touch surface but do not penetrate turf. If rake tips penetrate turf, improper debris pickup could result.

1. Position sweeper on a level surface.
2. Loosen locknut on depth adjustment bolt so it can be turned.

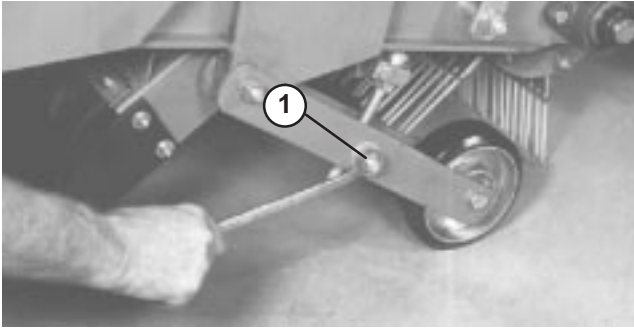

Figure 7

1. Locknut

3. Turn depth adjustment bolt until rake slightly contacts top of turf grass. If a broom is installed, slight contact should be made with surface. When broom is operating, the contact width surface should be about 1" wide across entire length of broom.

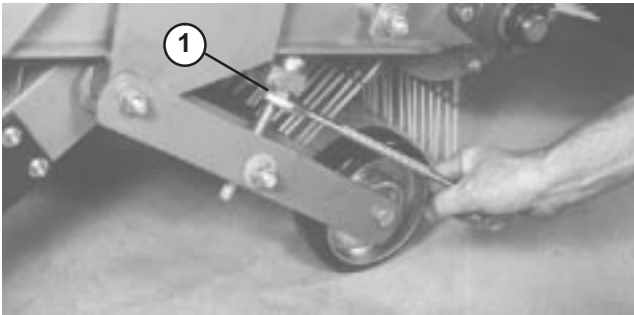

Figure 8

1. Depth adjusting bolt

4. Repeat procedure on opposite side of machine.
5. Retighten adjustment lock nut.

Adjust Rubber Flap

For best debris pick up results, metal portion of front flap should be vertical to ground.

1. Move flat lever forward to lower flat.

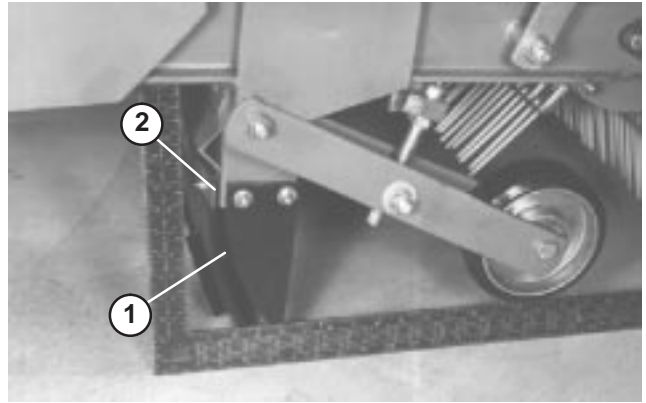

Figure 9

1. Rubber flap
2. Metal edge

2. Loosen jam nut on top of stop and rotate adjustment bolt up or down until flap is vertical to ground.

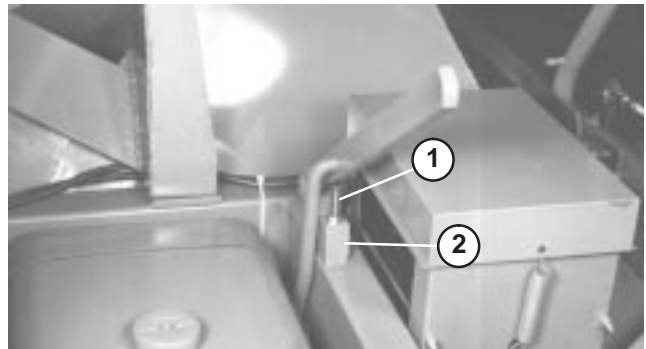

Figure 10

1. Adjustment bolt
2. Stop

3. Tighten jam nut to secure adjustment.

Note: Flap may be positioned in raised position when picking up large amounts of leaves.

Operation

Note: Determine the left and right sides of the machine from the normal operating position.

Controls

Flap Lever

Move flap lever (Fig. 11) downward to engaged position and upward for disengaged position. Move lever to upward position when transporting machine.

Reel Lever

Push reel lever (Fig. 11) forward to raise flex tip reel. To lower flex reel, push lever forward until catch releases, then push to rear until lever hits STOP. Move lever to raised position when sweeper is not in operation, when storing machine or when transporting machine.

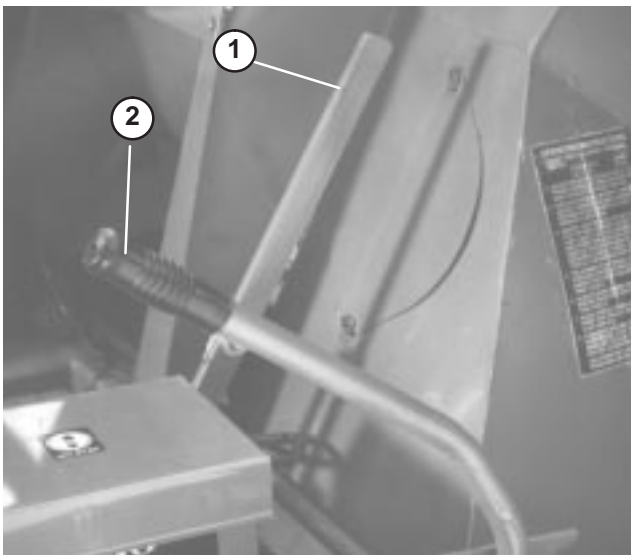

Figure 11

1. Flap lever
2. Reel lever

Choke Control

To start a cold engine, close carburetor choke by moving choke control lever (Fig. 12) to the “ON” position. After engine starts, regulate choke to keep engine running smoothly. As soon as possible, open the choke by moving lever to the “OFF” position. Starting a warm engine requires little or no choking.

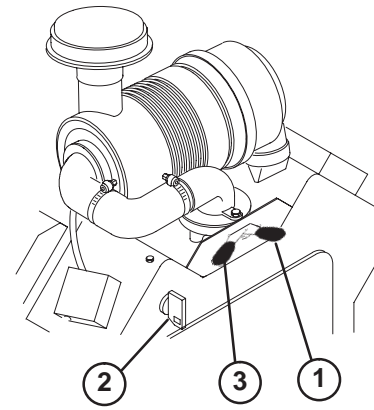

Figure 12

1. Choke control
2. Ignition switch
3. Throttle control

Ignition Switch

The ignition switch (Fig. 12), which is used to start and stop the engine, has three positions: OFF, RUN and START. Rotate key clockwise — START position — to engage starter motor. Release key when engine starts. The key will move automatically to the ON position. To shut engine off, rotate key counterclockwise to the OFF position.

Throttle Control

Throttle (Fig. 12) is used to operate engine at various speeds. Moving throttle lever to FAST position increases engine speed. To decrease engine speed, move lever to SLOW position.

Tailgate Latch Rope

Pull tailgate latch rope (Fig. 13) to unlatch tailgate when emptying hopper.

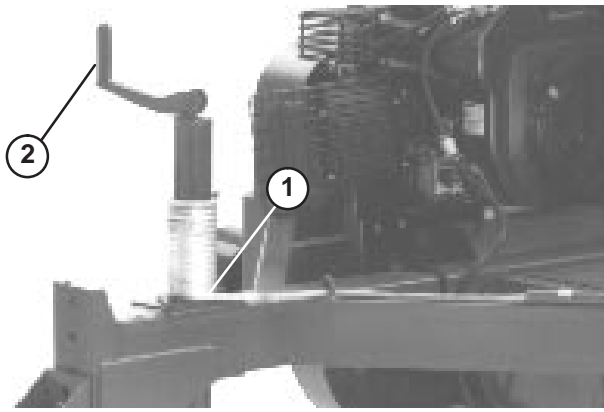

Figure 13

1. Tailgate latch rope 2. Jack handle

Starting Instructions

1. Place all controls in disengaged or off position.
2. Move throttle lever midway between SLOW and FAST position.
3. Move choke lever to ON position.

Note: Choke not required when starting a warm engine.

4. Insert key into ignition switch and rotate it clockwise to start the engine. Release key when engine starts. Regulate the choke to keep engine running smoothly.

Important To prevent overheating of the starter motor, do not engage starter longer than 10 seconds. After 10 seconds of continuous cranking, wait 60 seconds before engaging starter motor again.

5. Move throttle lever to desired engine speed.
6. Pull flap lever as far forward as possible.
7. Push rake lever to the rear as far as possible.
8. Engage rake by engaging clutch handle.

Note: Do not allow sweeper to stand still with rake engaged as turf damage may occur.

Stopping Instructions

1. Move throttle lever to “SLOW” position.
2. Move ignition switch to “OFF” position. Remove key from switch to prevent accidental starting.

Important To stop sweeper in an emergency, move ignition switch to “OFF” position.

Operating Tips

- Before starting to sweep, survey area to determine the best direction to sweep.

Note: To maintain a straight line when sweeping, sight of an object in the foreground.

- Always try to make a long, continuous run with a slight overlap on the return run.
- On turf areas, the flex tip reel will pick up twigs, clippings, leaves, pine needles and cones, small debris (beverage cans, small bottles, paper plates, etc.).
- The rake teeth are made of flexible nylon and easily changed. To prevent damage, the rake is protected from solid obstructions by spring action. The nylon teeth will not mar bronze, stone markers, sidewalks or pavement.
- Because of its unique design, the sweeper also grooms the turf. The flex tip reel combs through and lifts grass for a uniform cut when mowed. As it cleans, the light scarifying action increase water and pesticide penetration, thus reducing the need for renovation.

Important Do not make sharp turns when using the thatching reel as damage to turf may occur.

Important Do not operate sweeper while reel is turning and in the raised position. Damage to the rake and tires may result if teeth come in contact with tires.

Caution
<p>This product may exceed noise levels of 85 dB(A) at the operator position. Ear protectors are recommended, for prolonged exposure, to reduce the potential of permanent hearing damage.</p>

- To empty hopper, pull tailgate latch rope.

Inspection And Cleanup After Operation

- When sweeping has been completed, thoroughly clean and wash the machine. Air dry hopper. After cleaning, it is recommended that the machine be inspected for possible damage to mechanical components and blower. These procedures will assure that the machine will perform satisfactorily during next sweeping operation.

Important When towing sweeper for long distances, fasten gauge wheel arm securely to sweeper frame with transport hooks. Should gauge wheel arm fall to ground, damage to sweeper may occur.

Maintenance

Note: Determine the left and right sides of the machine from the normal operating position.

Important Refer to your engine operator's manual for additional maintenance procedures.

Lubrication

The Rake-O-Vac has grease fittings that must be lubricated regularly with No. 2 General Purpose Lithium Base Grease. Lubricate bearings after every 30 hours of operation or whenever machine is washed with water. Bearings and bushings must be lubricated daily when operating conditions are extremely dusty and dirty. Dusty and dirty operating conditions could cause dirt to get into the bearings and bushings, resulting in accelerated wear. The grease fittings that must be lubricated are the gauge wheel bearings (2) (Fig. 14); reel shaft bearings (2) (Fig. 14); impeller shaft bearings (2) (Fig. 15); Jackshaft bearings (2) (Fig. 16) left and right trailing arms (1 ea.) (Fig. 16).

1. Wipe grease fittings clean so foreign matter cannot be forced into the bearing or bushing.
2. Pump grease into the bearing or bushing.
3. Wipe up excess grease.

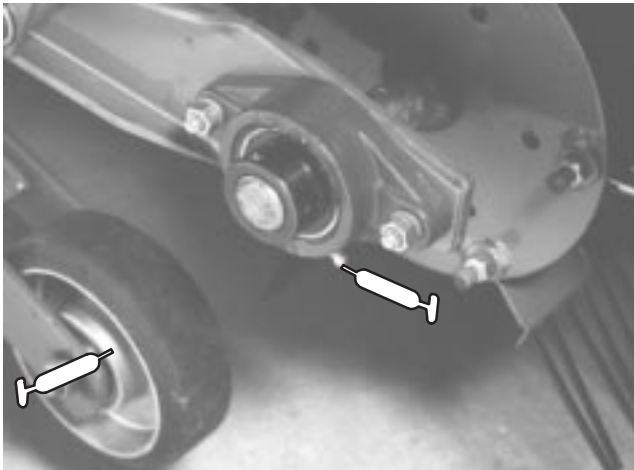

Figure 14

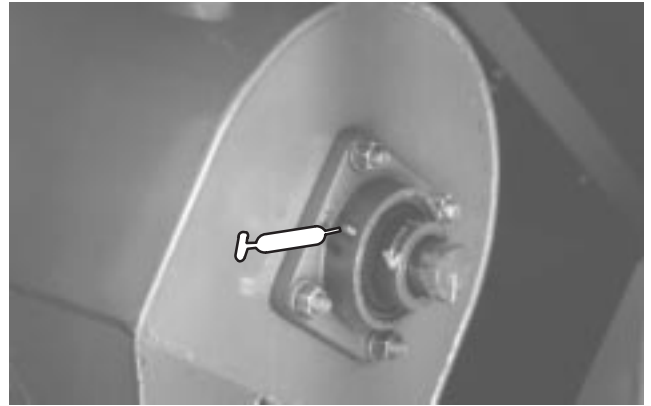

Figure 15

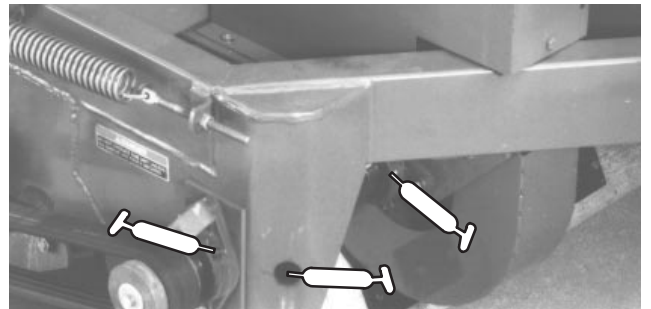

Figure 16

Oil Sweeper Jack

Sweeper jack must be oiled after every 50 hours of operation.



Figure 17

Changing Engine Oil and Filter

Change oil initially after the first 5 hours of operation, thereafter change oil every 100 hours and filter every 200 hours.

1. Park the machine on a level surface and turn the engine off.
2. Remove drain plug and let oil flow into drain pan. When oil stops, install drain plug.

Note: Warm oil flows better and carries more contaminants than cold oil.

3. Remove oil filter. Apply a light coat of clean oil to the new filter gasket.

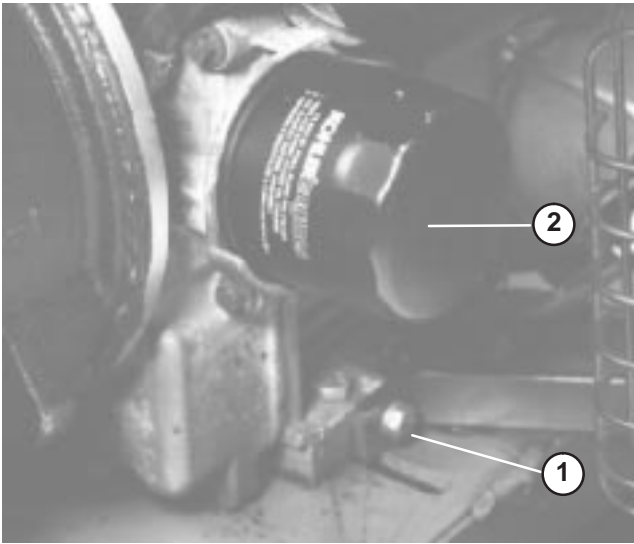

Figure 18

1. Drain plug
2. Oil filter

4. Screw filter on by hand until gasket contacts mounting plate, then tighten 1/2 turn further. **DO NOT OVER-TIGHTEN.**
5. Add oil to crankcase, refer to Check Engine Oil.
6. Dispose of used oil properly.

General Air Cleaner Maintenance

- Check air cleaner body for damage which could possibly cause an air leak. Replace a damaged air cleaner body.
- Service the air cleaner filters every 400 hours (more frequently in extreme dusty or dirty conditions). Do not over service air filter.
- Be sure cover is sealing around air cleaner body.

Servicing Air Cleaner

1. Release latches securing air cleaner cover to air cleaner body. Separate cover from body. Clean inside of air cleaner cover.

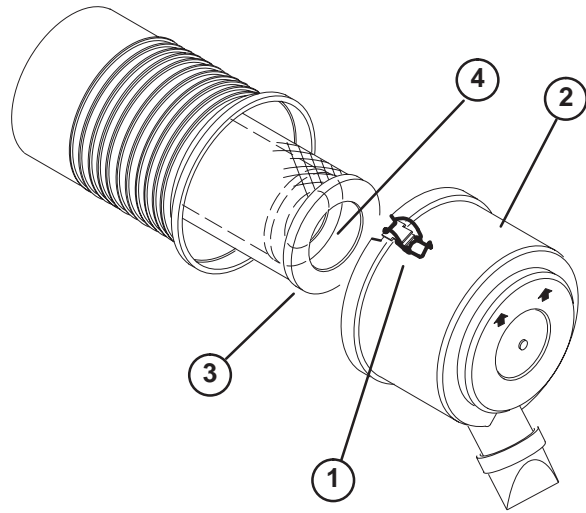

Figure 19

1. Air cleaner latches
2. Dust cup
3. Primary filter
4. Safety filter

2. Gently slide primary filter out of air cleaner body to reduce the amount of dust dislodged. Avoid knocking filter against air cleaner body. **Do not remove safety filter.**
3. Inspect primary filter and discard if damaged. Do not wash or reuse a damaged filter.

Important Never attempt to clean a safety filter. Replace the safety filter with a new one after every three primary filter services.

4. Blow compressed air from inside to the outside of dry filter element. Do not exceed 100 psi to prevent damage to the element.
5. Keep air hose nozzle at least 2" from filter and move nozzle up and down while rotating the filter element. Inspect for holes and tears by looking through the filter toward a bright light.
6. Inspect new filter for shipping damage. Check sealing end of filter. Do not install a damaged filter.
7. Insert new filter properly into air cleaner body. Make sure filter is sealed properly by applying pressure to outer rim of filter when installing. Do not press on flexible center of filter.
8. Reinstall cover and secure latches. Make sure cover is positioned with TOP side up.

Replacing Spark Plugs

Replace spark plugs or reset gap after every 200 operating hours to assure proper engine performance and reduce exhaust emission level.

Correct spark plug to use is a Champion RC 12YC or equivalent.

Recommended air gap is .040".

Note: The spark plug usually lasts a long time; however, the plug should be removed and checked whenever the engine malfunctions.

1. Clean area around spark plugs so foreign matter cannot fall into cylinder when spark plug is removed.
2. Pull spark plug wires off spark plugs and remove plugs from cylinder head.
3. Check condition of side electrode, center electrode, and center electrode insulator to assure there is no damage.

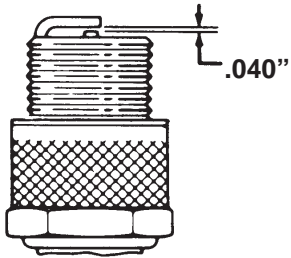

Figure 20

Important A cracked, fouled, dirty or otherwise malfunctioning spark plug must be replaced. Do not sand blast, scrape, or clean electrodes by using a wire brush because grit may eventually release from the plug and fall into the cylinder. The result is usually a damaged engine.

Removing Debris From Engine

To ensure proper cooling, make sure the grass screen, cooling fins and other external surfaces of the engine are kept clean at all times.

Every 100 hours of operation (more often under extremely dusty, dirty conditions) remove the blower housing and other cooling shrouds and clean the cooling fins and external surfaces as necessary. Make sure cooling shrouds are reinstalled.

Note: Operating the engine with a blocked grass screen, dirty or plugged cooling fins or cooling shrouds removed, will cause engine damage due to overheating.

Replace Fuel Filter

Replace fuel filter after every 600 hours of operation.

1. Place a clean container under fuel filter.
2. Remove clamps securing fuel filter to fuel lines.

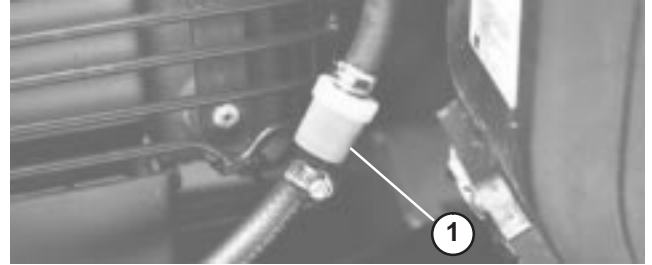



Figure 21

1. Fuel filter

3. Install new fuel filter to fuel lines with clamps previously removed. Filter to be mounted so arrow points toward carburetor.

Changing Rubber Flap

Replace rubber flap when it becomes worn or damaged.

	Caution	
Change rubber flap on a flat, level surface and block wheels to prevent sweeper from rolling. Failure to do so may result in personal injury.		

1. Remove (10) capscrews, washers, and nuts mounting flap and flap retainer.

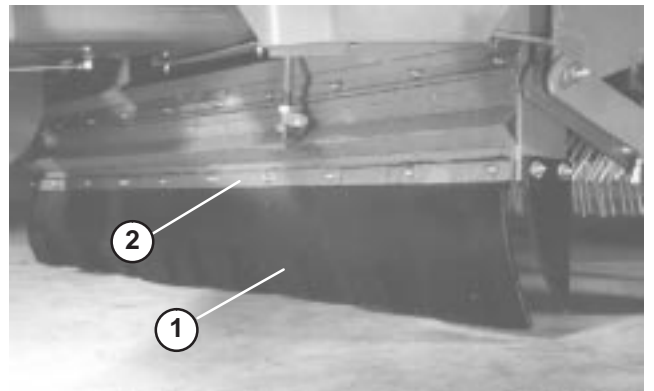

Figure 22

1. Rubber flap
2. Flap retainer

2. Replace with new rubber flap and fasten securely.

Cleaning Blower Housing



Warning



Before removing any debris from blower housing, disengage clutch, disengage P.T.O. drive, stop engine(s) and make certain all moving parts have stopped or personal injury may occur.

1. Make sure impeller has stopped rotating before removing access plates.
2. Loosen (2) wing nuts securing access plate.

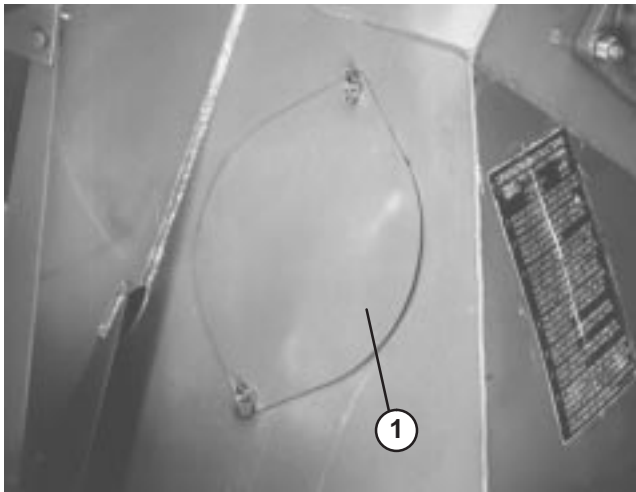

Figure 23

1. Access plate (2)

3. Swing access plate to one side allowing removal of debris.
4. After debris has been removed, lower access plate and secure with wing nuts. Repeat procedure on other access plate.

Adjusting Belts

Check condition and tension of belts after first day of operation and every 200 operating hours thereafter.

Impeller Drive Belt

1. Check tension by depressing belt at mid span of impeller and clutch pulleys with 4 to 5 lbs. of force. Belt should deflect .5 in. If deflection is incorrect, proceed to next step. If correct, continue operation.

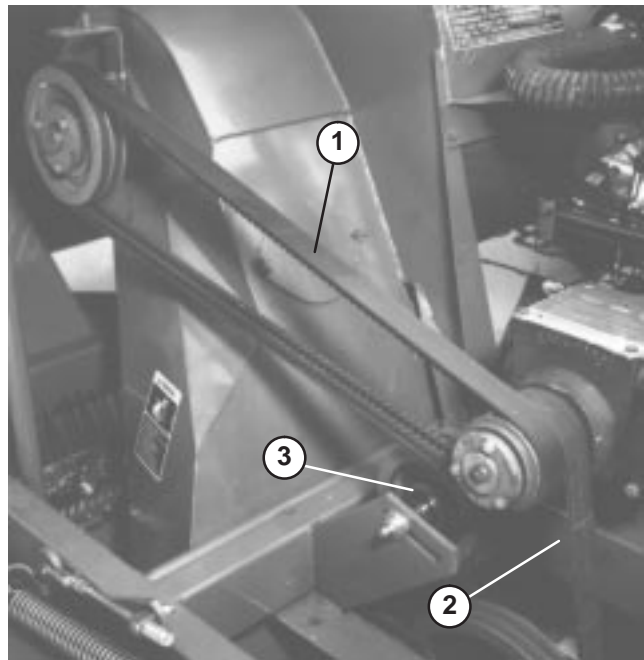

Figure 24

1. Impeller belt
2. Jackshaft belt
3. Idler pulley

Note: It is not necessary to remove upper belt guard (Fig. 25) to check belt tension. If for some reason belt guard must be removed, remove (4) capscrews, washers and nuts securing guard to frame. Never operate sweeper without guards in place.



Figure 25

1. Upper belt guard

2. To adjust belt tension:

- Loosen (4) engine mounting bolts.

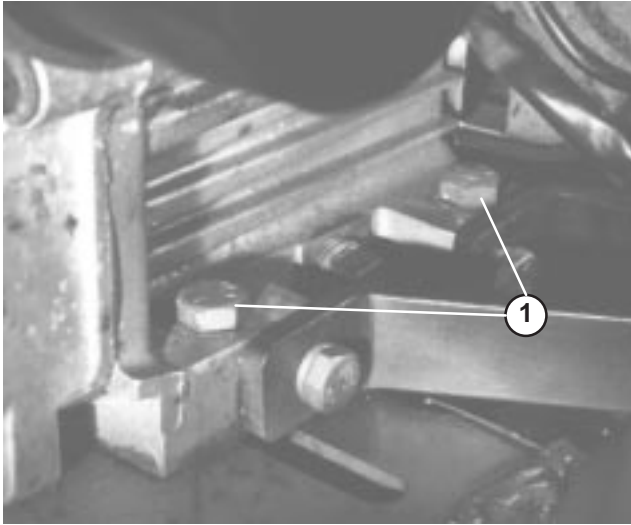

Figure 26

1. Engine mounting bolts
-

- Turn belt adjusting (Fig. 27) bolt until desired belt tension is obtained. Retighten engine mounting bolts. Reorient engine to make sure engine is parallel with frame. Retighten engine mounting bolts.

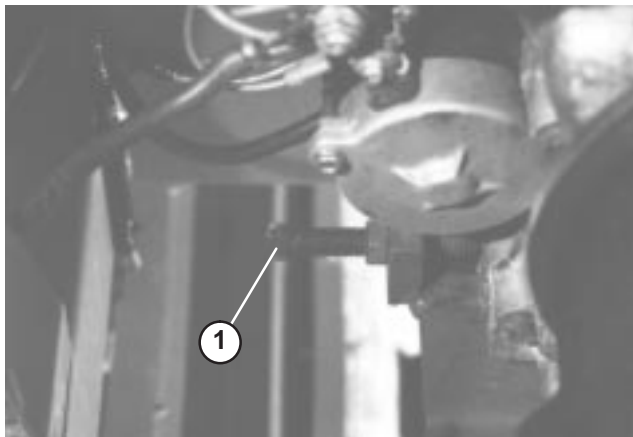

Figure 27

1. Adjusting bolt
-

3. Whenever impeller belt is adjusted it is necessary to readjust jackshaft belt (engine drive) or chain (PTO drive).

Jackshaft Belt

1. Check tension by depressing belt at mid span of jackshaft and clutch pulleys with 4 to 5 lbs. of force. Belt should deflect .25 in. If deflection is incorrect, proceed to next step. If correct, continue operation.
2. To adjust belt tension:
 - Remove (4) capscrews, washers and nuts securing upper shroud to frame (Fig. 25).
 - If belt has too much slack, loosen idler pulley nut, press forward on idler pulley until desired tension is obtained and retighten idler pulley nut.
 - If belt is too tight, loosen idler pulley nut, pull rearward on idler pulley until desired tension is obtained and retighten idler pulley nut.

Reel Drive Belt

1. Check tension by depressing belt at mid span of idler pulley and reel driver pulley with 25–29 lbs. of force. Belt should deflect .25 in. If deflection is incorrect, proceed to next step. If correct, continue operation.
2. To adjust belt tension:
 - Remove (2) capscrews, nut, retaining nut and washer securing lower belt guard to frame (Fig. 28). Remove guard.

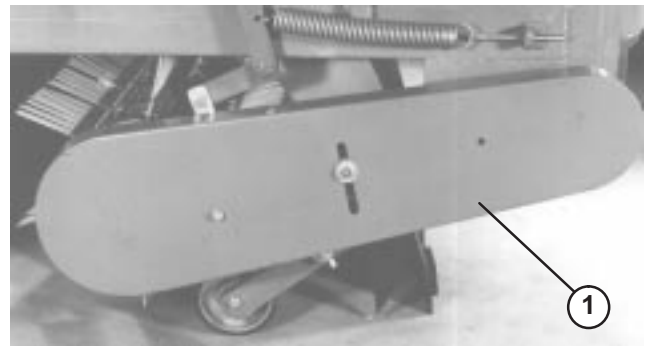

Figure 28

1. Lower belt guard
-

- If belt has too much slack, loosen idler pulley nut (Fig. 29), press down on idler pulley until desired tension is obtained and retighten idler pulley nut.
- If belt is too tight, loosen idler pulley nut (Fig. 29), pull upward on idler pulley until desired tension is obtained and retighten idler pulley nut.

- Reinstall guard. Make sure there is clearance between belt and belt guard.

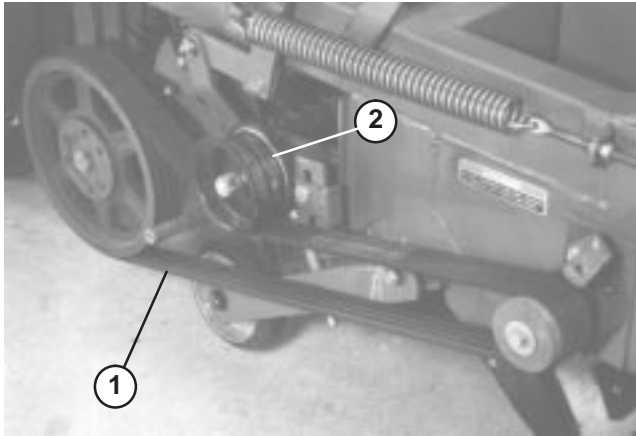

Figure 29

1. Reel drive belt 2. Idler pulley

Pulley Removal

To remove any pulley secured by a taper lock bushing, proceed as follows:

1. Remove capscrews and lockwashers one at a time and screw into adjoining holes.

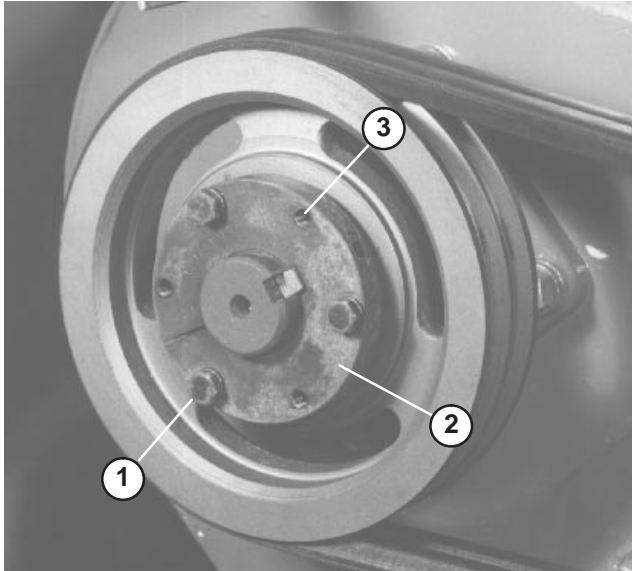

Figure 30

1. Capscrews & lockwasher 3. Taper lock release hole
2. Taper lock bushing

2. Turn each capscrew the same number of times until lock separates. Pulley will now slide off shaft.

Flex Tip Reel Removal

Removal of flex tip reel should be done on a hard and level surface.

1. Raise front of sweeper as high as possible by lowering jack.
2. Raise reel to highest position.
3. Remove lower belt guard (Fig. 28) and reel drive belt (Fig. 29).
4. Remove (2) capscrews, lockwashers and nuts securing reel shaft bearings to reel support arms on each side of sweeper. Lower flex tip reel to the ground.
5. Lift reel support arms to the highest position.
6. Slide end of rake rearward and pull out from under machine.

Thatcher Installation

A 32 tooth jackshaft sprocket, a 19 tooth idler sprocket and a No. 60 chain make up the Thatcher Kit Drive Components.

1. Remove lower belt guard (Fig. 28) and reel drive belt (Fig. 29).
2. Remove capscrew and washer securing jackshaft pulley to jackshaft and remove pulley.

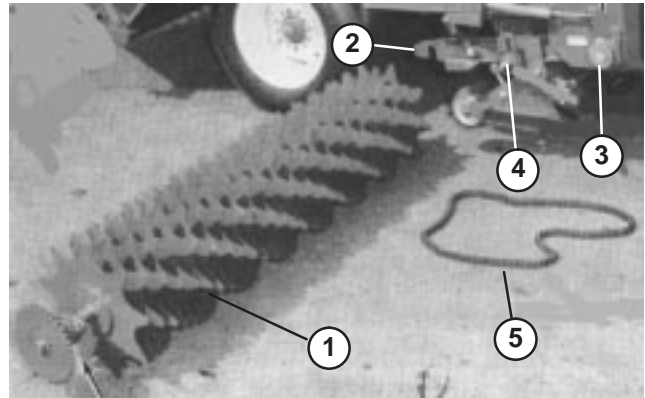

Figure 31

1. Thatcher reel 4. Idler sprocket
2. Reel support arm 5. Chain
3. Jackshaft sprocket

3. Slide 16 Tooth Jackshaft sprocket onto jackshaft.
4. Secure by tightening two (2) set screws and lock nuts on sprocket hub.
5. Remove idler pulley presently on machine and replace it with 19 tooth (#60) idler sprocket supplied with Thatcher Kit.

6. Slide Thatcher into position and secure to reel support arms.
7. Align idler sprocket with jackshaft sprocket and thatcher sprocket.
8. Install No. 60 chain, included in kit. Lubricate with SAE 30 oil.
9. Push down on idler sprocket until desired chain tension is obtained.
10. Fasten idler sprocket securely.

Note: Spacers mounted on lift mechanism adjusting screws must be removed when thatcher is installed on machine.

11. Put reel support arms in a lowered position.
12. Remove jam nut and adjusting screw. Slide spacer off adjusting screw.

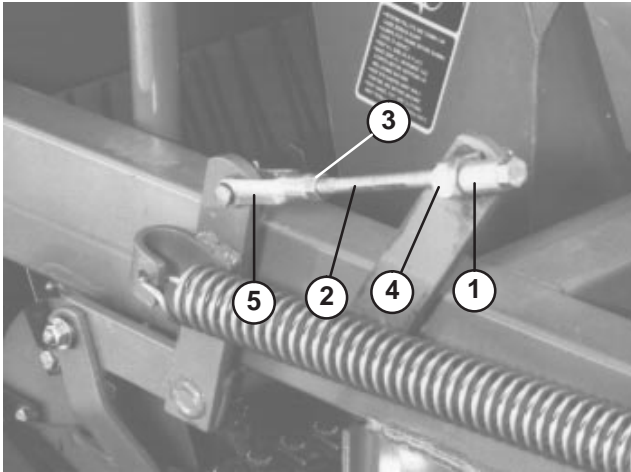

Figure 32

- | | |
|--------------------|----------------|
| 1. Spacer | 4. Pivot block |
| 2. Adjusting screw | 5. Clevis |
| 3. Jam nut | |

13. Reassemble jam nut and adjusting screw with spacer positioned on adjusting screw between pivot block and clevis. This is the storage position for spacer during thatcher operation.

14. Repeat procedure on other side of sweeper.

Note: Spacers should be re-installed whenever the thatcher is removed and either the brush or flex tip reel is mounted to sweeper.

Flex Tip Rake Rod Or Finger Plate Replacement

1. Remove capscrew and locknut from one end of reel.
2. Remove locknut only, from opposite end of reel.
3. Drive rod from end plate. Drive rod from end without the tab welded to it.
4. Remove finger plates or rods as required and replace.
5. Line up finger plate with rod and drive rod back through end plate.
6. Attach capscrew and locknuts and hook up springs.

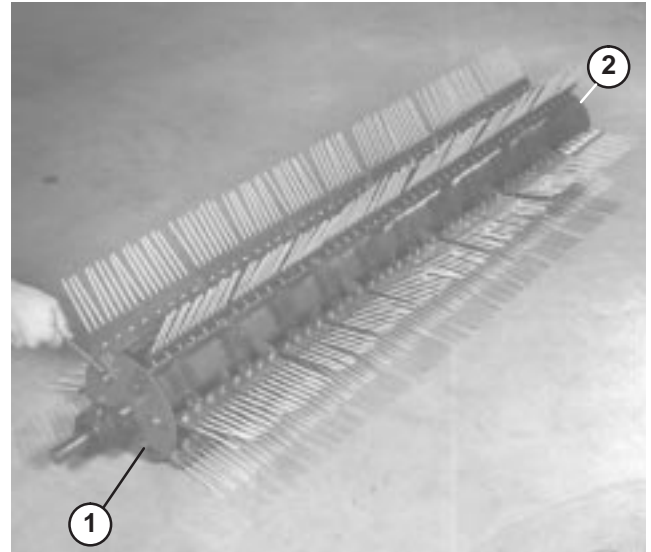

Figure 33

- | | |
|-------------------------|------------|
| 1. Capscrew and locknut | 2. Locknut |
|-------------------------|------------|

Flex Tip Rake Tine Replacement

1. Remove tine retainer and slide damaged tine out.

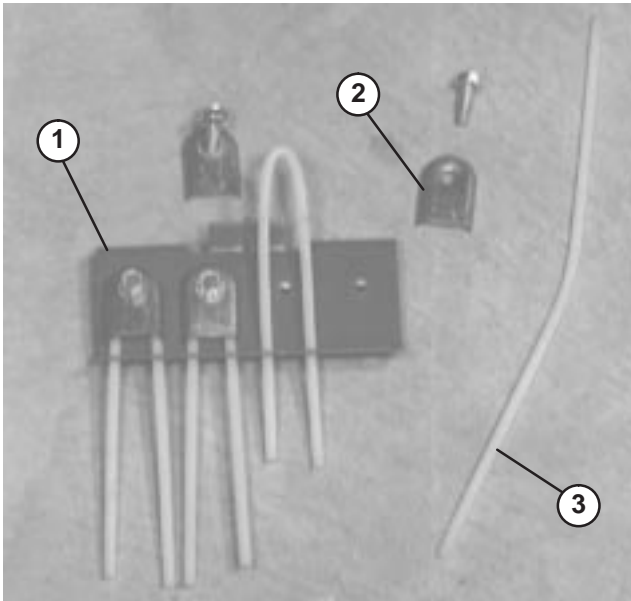

Figure 34

1. Finger plate
 2. Tine retainer
 3. Tine
-
2. Bend new tine in half and slide into position.
 3. Place tine bracket over curved end of tine and fasten securely with capscrew and lockwasher.

Brush Half Replacement

1. Remove brush from sweeper.
2. Loosen clamps with a allen wrench and remove from brush halves.



Figure 35

1. Clamp
-
3. Separate brush halves and discard damaged section(s).

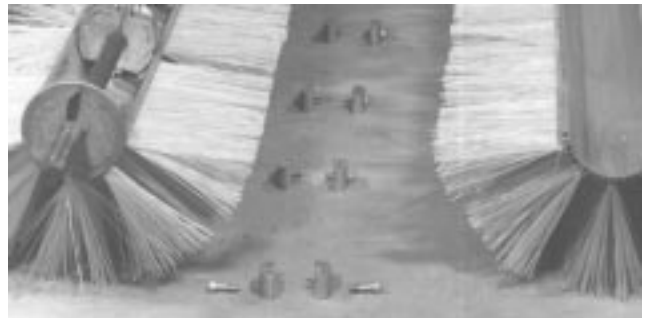



Figure 36

4. Install new brush section(s) by pushing together and secure both ends with brush clamps. When ends have been secured, fasten brush with remaining clamps.

Changing Tires

1. Park machine on a flat, level surface. Block other tire to prevent accidental rolling or injury.
2. Place jack under frame or axle shaft behind wheel and jack up wheel until it just contacts floor.



 **Warning** 

A 2000 lb. capacity hydraulic jack should be used when changing a tire.

3. Loosen all lug bolts and continue to jack up until tire can be removed.
4. Reverse above procedure to install tire. Torque lug bolts to 70 to 90 ft.-lbs.

Battery Care



- Battery electrolyte level must be properly maintained and the top of the battery kept clean. If the machine is stored in a location where temperatures are extremely high, the battery will run down more rapidly than if the machine is stored in a location where temperatures are cool.

 **Danger** 

Battery electrolyte contains sulfuric acid which is a deadly poison and causes severe burns.

- **Do not drink electrolyte and avoid contact with skin, eyes or clothing. Wear safety glasses to shield your eyes and rubber gloves to protect your hands.**
- **Fill the battery where clean water is always available for flushing the skin.**

- Keep top of battery clean by washing periodically with a brush dipped in ammonia or bicarbonate of soda solution. Flush the top surface with water after cleaning. Do not remove the fill cap while cleaning.
- Battery cables must be tight on terminals to provide good electrical contact.



 **Warning** 

CALIFORNIA

Proposition 65 Warning



Battery posts, terminals, and related accessories contain lead and lead compounds, chemicals known to the State of California to cause cancer and reproductive harm. Wash hands after handling.

- If corrosion occurs at terminals, disconnect cables, negative (-) cable first and scrape clamps and terminals separately. Reconnect cables, positive (+) cable first and coat terminals with petroleum jelly.
- Check the electrolyte level every 25 operating hours or, if machine is in storage, every 30 days.
- Maintain cell level with distilled or demineralized water. Do not fill cells above fill line.
- If machine will be stored for more than 30 days, remove the battery and charge it fully. Either store it on the shelf on the machine. Leave the cables disconnected if stored on the machine. Store the battery in a cool atmosphere to avoid quick deterioration of the charge in the battery. To prevent battery from freezing, make sure it is fully charged. The specific gravity of a fully charged battery is 1.250.

 **Warning** 

Charging the battery produces gasses that can explode.

Never smoke near the battery and keep sparks and flames away from battery.

 **Warning** 

Battery terminals or metal tools could short against metal tractor components causing sparks. Sparks can cause the battery gasses to explode, resulting in personal injury.

- **When removing or installing the battery, do not allow the battery terminals to touch any metal parts of the tractor.**
- **Do not allow metal tools to short between the battery terminals and metal parts of the tractor.**



The Toro General Commercial Products Warranty

A Two-Year Limited Warranty

Conditions and Products Covered

The Toro Company and its affiliate, Toro Warranty Company, pursuant to an agreement between them, jointly warrant your Toro Commercial Product ("Product") to be free from defects in materials or workmanship for two years or 1500 operational hours*, whichever occurs first. Where a warrantable condition exists, we will repair the Product at no cost to you including diagnosis, labor, parts, and transportation. This warranty begins on the date the Product is delivered to the original retail purchaser.

* Product equipped with hour meter

Instructions for Obtaining Warranty Service

You are responsible for notifying the Commercial Products Distributor or Authorized Commercial Products Dealer from whom you purchased the Product as soon as you believe a warrantable condition exists.

If you need help locating a Commercial Products Distributor or Authorized Dealer, or if you have questions regarding your warranty rights or responsibilities, you may contact us at:

Toro Commercial Products Service Department
Toro Warranty Company
8111 Lyndale Avenue South
Bloomington, MN 55420-1196
952-888-8801 or 800-982-2740
E-mail: commercial.service@toro.com

Owner Responsibilities

As the Product owner, you are responsible for required maintenance and adjustments stated in your operator's manual. Failure to perform required maintenance and adjustments can be grounds for disallowing a warranty claim.

Items and Conditions Not Covered

Not all product failures or malfunctions that occur during the warranty period are defects in materials or workmanship. This express warranty does not cover the following:

- Product failures which result from the use of non-Toro replacement parts, or from installation and use of add-on, modified, or unapproved accessories
- Product failures which result from failure to perform required maintenance and/or adjustments
- Product failures which result from operating the Product in an abusive, negligent or reckless manner
- Parts subject to consumption through use unless found to be defective. Examples of parts which are consumed, or used up, during normal Product operation include, but are not limited to, blades, reels, bedknives, tines, spark plugs, castor wheels, tires, filters, belts, etc.

Countries Other than the United States or Canada

Customers who have purchased Toro products exported from the United States or Canada should contact their Toro Distributor (Dealer) to obtain guarantee policies for your country, province, or state. If for any reason you are dissatisfied with your Distributor's service or have difficulty obtaining guarantee information, contact the Toro importer. If all other remedies fail, you may contact us at Toro Warranty Company.

- Failures caused by outside influence. Items considered to be outside influence include, but are not limited to, weather, storage practices, contamination, use of unapproved coolants, lubricants, additives, or chemicals, etc.
- Normal "wear and tear" items. Normal "wear and tear" includes, but is not limited to, damage to seats due to wear or abrasion, worn painted surfaces, scratched decals or windows, etc.

Parts

Parts scheduled for replacement as required maintenance are warranted for the period of time up to the scheduled replacement time for that part.

Parts replaced under this warranty become the property of Toro. Toro will make the final decision whether to repair any existing part or assembly or replace it. Toro may use factory remanufactured parts rather than new parts for some warranty repairs.

General Conditions

Repair by an Authorized Toro Distributor or Dealer is your sole remedy under this warranty.

Neither The Toro Company nor Toro Warranty Company is liable for indirect, incidental or consequential damages in connection with the use of the Toro Products covered by this warranty, including any cost or expense of providing substitute equipment or service during reasonable periods of malfunction or non-use pending completion of repairs under this warranty. Except for the Emissions warranty referenced below, if applicable, there is no other express warranty. All implied warranties of merchantability and fitness for use are limited to the duration of this express warranty.

Some states do not allow exclusions of incidental or consequential damages, or limitations on how long an implied warranty lasts, so the above exclusions and limitations may not apply to you.

This warranty gives you specific legal rights, and you may also have other rights which vary from state to state.

Note regarding engine warranty: The Emissions Control System on your Product may be covered by a separate warranty meeting requirements established by the U.S. Environmental Protection Agency (EPA) and/or the California Air Resources Board (CARB). The hour limitations set forth above do not apply to the Emissions Control System Warranty. Refer to the Engine Emission Control Warranty Statement printed in your operator's manual or contained in the engine manufacturer's documentation for details.