



Top Dresser 2500

Model No. 44507-220000001 and Up

Operator's Manual

FOREWORD

The Topdresser 2500 has advanced concepts in engineering, design and safety; and if maintained properly, will give excellent service.

Since this is a high-quality product, Toro is concerned about the future use of the machine and safety of the user. Therefore, read this manual to familiarize yourself with proper set-up, operation and maintenance instructions. The major sections of the manual are:

- | | | |
|------------------------|---------------------|----------------|
| 1. Safety Instructions | 3. Before Operating | 5. Maintenance |
| 2. Set-up Instructions | 4. Lubrication | |

Certain information in this manual is emphasized. DANGER, WARNING and CAUTION identify personal safety related information. IMPORTANT identifies mechanical information demanding special attention. Be sure to read this directive because it deals with the possibility of damaging a part or parts of the machine. NOTE identifies general information worthy of special attention.

TABLE OF CONTENTS

| | Page | | Page |
|---|------|--|------------|
| SAFETY INSTRUCTIONS | 3 | Sand Precautions | 16 |
| SAFETY AND INSTRUCTION DECALS | 5 | Cold Weather Operation | 16 |
| SPECIFICATIONS | 7 | LUBRICATION | 17 |
| LOOSE PARTS | 7 | Greasing Bearings | 17 |
| SPECIAL TOW VEHICLE INSTRUCTIONS | 9 | MAINTENANCE | 18 |
| SET-UP INSTRUCTIONS | 10 | Jacking Topdresser | 18 |
| Install Tongue | 10 | Changing Hydraulic Fluid | 18 |
| Install Tongue Hitch | 10 | Replacing Hydraulic Filter | 18 |
| Mount Tongue Jack | 10 | Checking Hydraulic Lines and Hoses | 18 |
| Install Wire Harness | 10 | Brush Adjustment | 19 |
| Mount Skids | 10 | Tensioning Drive Chains | 19 |
| BEFORE OPERATING | 11 | Adjusting Conveyor Belt | 20 |
| Check Hydraulic Fluid | 11 | Replacing Conveyor Belt | 20 |
| Check Tire pressure | 12 | HYDRAULIC SYSTEM DIAGNOSTICS | 22 |
| Check Wheel Bolt Torque | 12 | Hydraulic Flow Rates and Speed Table | 22 |
| CONTROLS | 12 | TROUBLE SHOOTING | 24 |
| Gate Metering Control | 13 | HYDRAULIC SCHEMATIC | 25 |
| Rate Scale | 13 | ELECTRICAL SCHEMATIC | 26 |
| Hand Control Switch | 13 | SEASONAL STORAGE | 27 |
| OPERATING INSTRUCTIONS | 14 | IDENTIFICATION AND ORDERING | 27 |
| General | 15 | WARRANTY | Back Cover |
| Operation | 15 | | |
| Sand Application Rate | 16 | | |

SAFETY INSTRUCTIONS

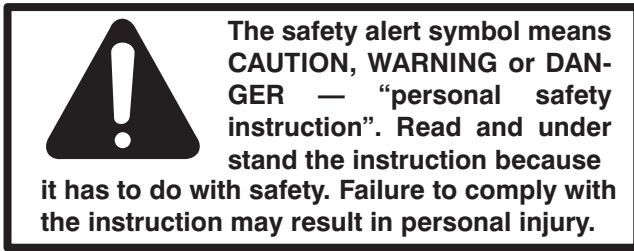

BEFORE OPERATING

1. Read and understand the contents of this Operator’s Manual before operating the machine. Become familiar with all controls and know how to stop quickly. A free replacement manual is available by sending complete Model and Serial Number to:

The Toro Company
8111 Lyndale Avenue South
Bloomington, Minnesota 55420–1196

2. Never allow children to operate the machine. Do not allow adults to operate the machine without proper instructions. Only trained and authorized persons should operate this vehicle. Anyone who operates the vehicle should have a motor vehicle license.

3. Never operate the machine when under the influence of drugs or alcohol.

4. Keep all shields and safety devices in place. If a shield, safety device or decal is illegible or damaged, repair or replace it before operation is commenced.

5. Tighten any loose nuts, bolts and screws to assure machine is in safe operating condition. Make sure Topdresser tongue mounting pins, hitch pins and tongue jack are in place and secure.

6. Do not modify this equipment in any manner.

7. Do not operate machine while wearing sandals, tennis shoes, sneakers or shorts. Also, do not wear loose fitting clothing which could get caught in moving parts. Always wear long pants and substantial shoes. Wearing safety glasses, safety shoes and a helmet is advisable and required by some local ordinances and insurance regulations.

WHILE OPERATING

8. Do not run the engine in a confined area without adequate ventilation. Exhaust fumes are hazardous and could possibly be deadly.

9. NEVER carry passengers on the Top Dresser and keep everyone away from the areas of operation.

10. Keep hands and feet out of hopper when unit is operating or engine is running on tow vehicle.

11. Operator and passenger should remain seated whenever the tow vehicle is in motion.

12. Using the machine demands attention. Failure to operate tow vehicle safely may result in an accident, tipover of tow vehicle and serious injury or death. Drive carefully. To prevent tipping or loss of control:

A. Use extreme caution, reduce speed and maintain a safe distance around sand traps, ditches, creeks, ramps, any unfamiliar areas or other hazards.

B. Watch for holes or other hidden hazards.

C. Use caution when operating tow vehicle on a steep slope. Normally travel straight up and down slopes. Reduce speed when making sharp turns or when turning on hillsides. Avoid turning on hillsides whenever possible.

D. Use extra caution when operating tow vehicle on wet surfaces, at higher speeds or with a full load. Stopping time will increase with a full load. Shift into a lower gear before starting up or down a hill

E. Avoid sudden stops and starts. Do not go from reverse to forward or forward to reverse without coming to a complete stop.

F. Do not attempt sharp turns or abrupt maneuvers or other unsafe driving actions that may cause a loss of control.

G. Before backing up, look to the rear and assure no one is behind. Back up slowly.

H. Watch out for traffic when near or crossing roads. Always yield the right of way to pedestrians and other vehicles. **This machine is not designed for use on streets or highways.** Always signal your turns or stop early enough so other persons know what you plan to do. Obey all traffic rules and check for local regulations on the operation of the topdresser on or near highways.

I. Always watch out for and avoid low over-hangs such as tree limbs, door jambs, over-head walkways, etc. Make sure there is enough room over head to easily clear the tow vehicle and your head.

J. If ever unsure about safe operation, STOP WORK and ask your supervisor.

13. When loading with sand, distribute load evenly. Operate tow vehicle with extra caution when the hopper is full of sand. Keep load balanced to prevent it from shifting.

MAINTENANCE

14. Before servicing or making adjustments to the topdresser, stop engine of tow vehicle, set parking brake and remove key from engine to prevent accidental starting of the engine.

15. Perform only those maintenance instructions described in this manual. If major repairs are ever needed or assistance is desired, contact an Authorized TORO Distributor.

SAFETY INSTRUCTIONS

16. Be sure machine is in safe operating condition by keeping nuts, bolts and screws tight.

17. Make sure all hydraulic line connectors are tight, and all hydraulic hoses and lines are in good condition before applying pressure to the system.

18. Keep body and hands away from pin hole leaks in hydraulic lines that eject high pressure hydraulic fluid. Use cardboard or paper to find hydraulic leaks. Hydraulic fluid escaping under pressure can penetrate skin and cause injury. Fluid accidentally injected into

the skin must be surgically removed within a few hours by a doctor familiar with this form of injury or gangrene may result.

19. To ensure optimum performance and safety, always purchase genuine TORO replacement parts and accessories to keep the Toro all TORO. NEVER USE "WILL-FIT" REPLACEMENT PARTS AND ACCESSORIES MADE BY OTHER MANUFACTURERS. Look for the TORO logo to assure genuineness. Using unapproved replacement parts and accessories could void the warranty of The Toro Company.

SAFETY AND INSTRUCTION DECALS

The following decals are installed on the machine. If any become damaged or illegible, replace it. The decal part number is listed below and in your parts catalog. Replacement can be ordered from your Authorized Toro Distributor.

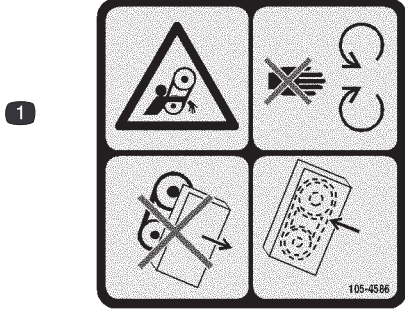

105-4586

1. Entanglement hazard, belt—stay away from moving parts. Do not remove the shields or guards; always keep the shields and guards in place.

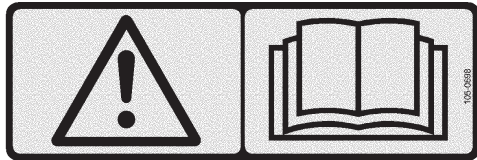

105-0698

1. Warning—read the *Operator's Manual*.

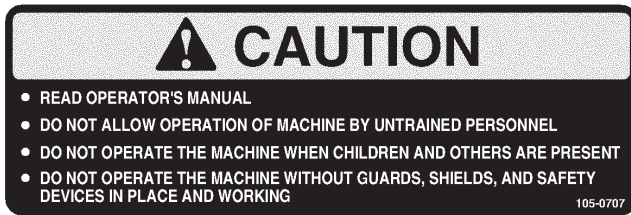

105-0707

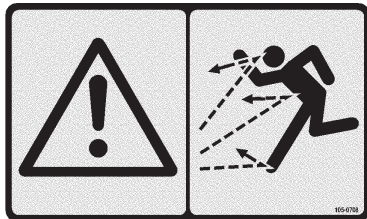

105-0708

1. Warning—thrown objects

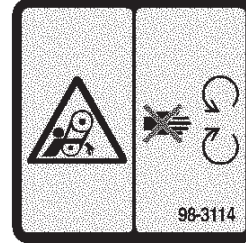

98-3114

1. Entanglement hazard—stay away from moving parts.

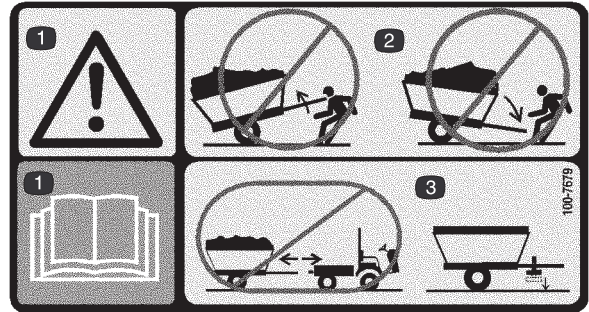

100-7679

1. Warning—read the *Operator's Manual*.
2. Do not disconnect a trailer with an unbalanced load; it may swing up or down and injure you.
3. Do not disconnect the trailer without first putting down the jack.

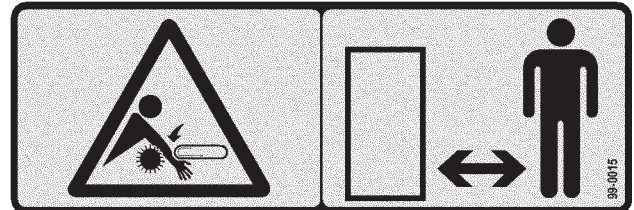

99-0015

1. Entanglement hazard, conveyor and brush—stay a safe distance from the conveyor and brush.



58-6520

1. Grease

SAFETY AND INSTRUCTION DECALS

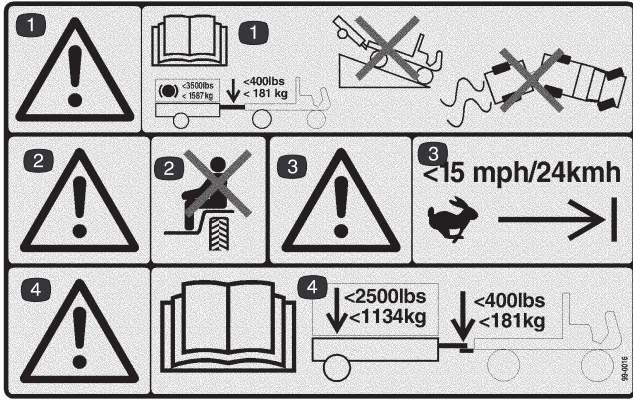

99-0016

1. Warning—read the *Operator's Manual* for information on stopping the machine; the maximum braking load is 3500 lb. (1587 kg) trailer weight and 400 lb (181 kg) tongue weight. Do not drive the machine and trailer down hill or you may lose control.
2. Warning—do not carry passengers.
3. Warning—do not exceed 15 mph (24 kmh).
4. Warning—maximum tongue weight is 400 lb. (181 kg); maximum trailer weight is 2500 lb. (1134 kg).

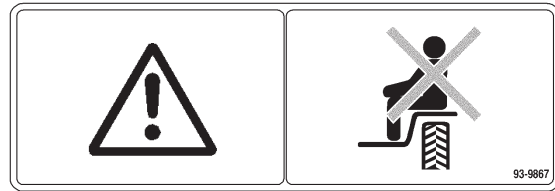

93-9867

1. Warning—do not carry passengers.

SPECIFICATIONS

Dimensions:

Height: 42.5
Length (plus tongue): 60.5"
Overall Length: 101.5"
Width: 73"

Hopper Dimensions:

Height: 15.3"
Top Length: 37.5"
Width: 73"
Inside Clear Width: 69"

Hopper Capacity:

25 cubic feet or 2050 lbs.

Spreading Width:

60"

Top Dressing Speed:

Variable to desired application rate.
2 to 8 mph

Maximum Transport Speed:

15 mph – Not for highway use.

Conveyor Belt:

Continuous 60" wide traction grip PVC belt with heavy duty monofilament carcass.

Metering Gate:

Spring release flexible edge gate variable from closed to 3" opening for light to heavy applications.

Tires:

(4) 18 x 10.5–8, 4 ply ribbed. Inflate to 20–30 psi.

Drive:

Hydraulic with chain driven pumps. Conveyor motor with chain reduction. Brush motor direct drive. Electro hydraulic solenoid control to activate top dresser motors. Mobil DTE 15 M hydraulic fluid in a closed loop hydraulic system with charge pump and 10 micron filter.

Shipping Weight:

1454 lbs.

Maximum Weight:

3500 lbs. (GVW)

Required Attachments:

Topdresser Hydraulic Brake Kit Part No. 99–0154
Workman Heavy Duty Drawbar Model No. 44212
or
Heavy Duty Hitch frame Model No. 44213

Recommended Accessories:

Tachometer Kit (Liquid Cooled Gas or Diesel Workman) Part No. 87–9950
Tachometer Kit–CE (Liquid Cooled Gas or Diesel Workman) Part No. 87–9970
Tachometer Kit (Air Cooled Gas Workman) Part No. 87–9960
Hand Throttle Kit Model No. 07416

Optional Accessories:

Tongue Jack (CE) Part No. 98–5016
Mobil EAL 224 H Biodegradable hydraulic fluid (5 gal. container) Part No. 100–7674
Oil Filter Part No. 83–3010
Extra Vehicle Harness Part No. 99–0198

Specifications and design subject to change without notice.

LOOSE PARTS

NOTE: Use this chart as a checklist to assure all parts have been received. Without these parts, total set-up cannot be completed.

| DESCRIPTION | QTY. | USE |
|---|------------------|--|
| Tongue Assembly Lynch Pin Clevis Pin | 1 4 2 | Mount Tongue Assembly to Topdresser |
| Wire Harness (3 pc.) Hitch Pin | 1 1 | Mount to Tongue Assembly & Tow Vehicle |
| Skid Plates Carriage Bolt Flat Washer Lock Nut | 4 8 8 8 | Mount to Topdresser |
| Operator's Manual Parts Catalog | 2 1 | Read Before Operating Machine |
| Registration Card CE Certificate of Compliance | 1 1 | Fill out and return to Toro |
| Pre-Delivery Check Inspection | 1 | Fill out and return to Toro |

SPECIAL TOW VEHICLE INSTRUCTIONS

Special Instructions for Workman (3000/4000) and other utility tow vehicles (tractors):

1. The TopDresser 2500 can be towed by most utility tractors equipped with flotation tires for operation over golf greens. The tractor must have adequate brakes and drawbar hitch capacity to handle a 3500 lbs. (1587 kg.) trailer. Refer to Tractor Operator's Manual for towing instruction and precautions.

2. The Workman(3000/4000) vehicle, equipped with the Heavy Duty Drawbar (Model 44212 or 44213) makes a good tow vehicle (4WD version is best for hilly or bermed approaches to greens).

NOTE: For improved traction and when towing TopDresser 2500, 1000 lbs. of weight can be added to vehicle bed.

IMPORTANT: Do Not attempt pulling the Topdresser 2500 when loaded with material, with the standard Workman (3000/4000) hitch. It is only rated to 1500 lbs. and may bend or damage the cross tube axle support or rear spring shackles. Always use the H.D. Drawbar Kit Model 44212 or H.D. Frame Drawbar Model 44213.

IMPORTANT: Do Not attempt towing a loaded topdresser with a light utility vehicle or run—about. They do not normally have adequate brakes, suspension, or frame strength to handle the weight of the TopDresser2500.

3. Trailer Brakes are highly recommended when using the Top Dresser 2500 in hilly terrain. When fully loaded the topdresser may weigh as much as 3500 lbs.(GVW). This weight is well over the recommended towing and braking limit of most utility vehicles. A special trailer brake kit is available for direct installation with the Workman (3000/4000) vehicle. This kit could be adapted to other vehicles with a 12 volt brake light source.

SET-UP INSTRUCTIONS

INSTALL TONGUE (Fig. 1 & 2)

1. Install tongue into topdresser receiving tube and secure each end with a clevis pin and (2) lynch pins (Fig. 1).

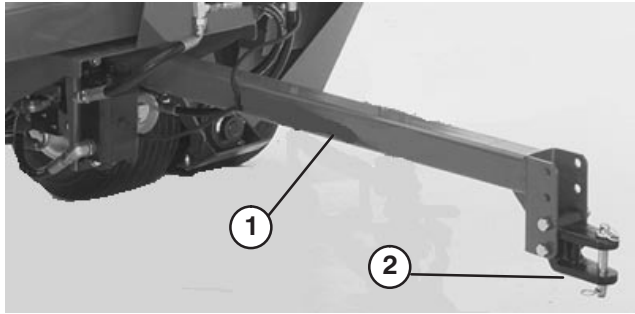

Figure 1

1. Front of Tongue
2. Tongue hitch



Figure 2

1. Rear of Tongue

INSTALL TONGUE HITCH (Fig. 1)

1. Level the tongue hitch to the tow vehicle drawbar and secure using appropriate holes.

MOUNT OPTIONAL TONGUE JACK (Fig. 3)

1. Slide tongue jack onto mounting tube on tongue.
2. Align holes in jack with tongue and secure with clevis pin.

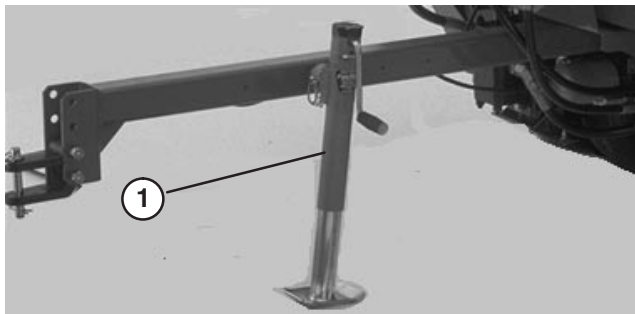

Figure 3

1. Tongue jack

3. For storage, jack can be removed or rotated upward and pinned.

INSTALL WIRE HARNESS (Fig. 4)

1. Plug topdresser wire harness into connector on topdresser solenoid valve.

2. Secure appropriate terminals of tow vehicle harness to tow vehicle battery (+ or -).

IMPORTANT: Make sure harness is connected to correct terminals on battery.

3. Unplug loop back connectors from each harness and plug harness's together.

Note: To prevent dirt or corrosion to harness connector pins, Install loop back connectors to connectors whenever vehicle harness's are disconnected.

4. Route wire harness' along tongue and secure to tongue with wire connectors.

5. Plug controller harness connector into topdresser wire harness connector. Route to operator's position and secure along frame rail.

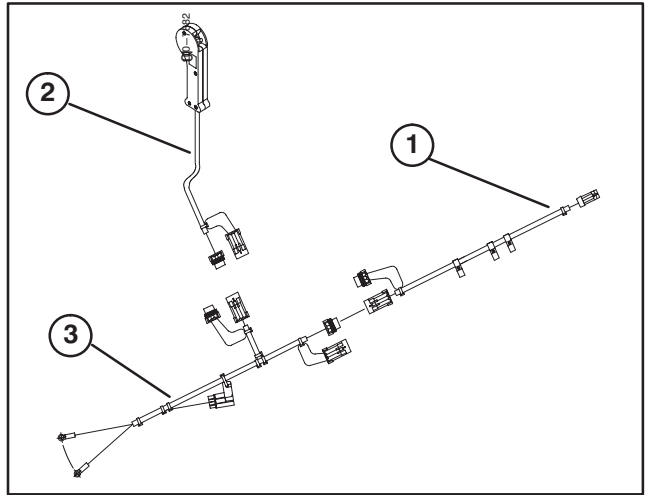

Figure 4

1. Topdresser harness
2. Controller harness
3. Tow vehicle harness

NOTE: Wire harness has removable connectors which allow permanently installing portion on vehicle, and leaving the other portion with topdresser plugged in to the solenoid.

MOUNT SKIDS (Fig. 5)

1. Mount a skid to each mounting bracket with (2) carriage bolts, flat washers and locknuts. Position skids as shown in figure 5.

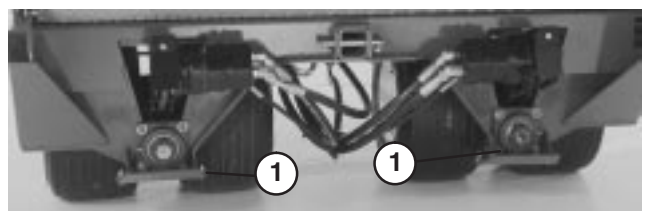

Figure 5

1. Skid (4)

BEFORE OPERATING

CHECK HYDRAULIC SYSTEM FLUID

The machine's reservoir is filled at the factory with approximately 2.5 gallons (9.5 l) of high quality hydraulic fluid. **Check the level of hydraulic fluid before the machine is first operated and daily thereafter.** Appropriate hydraulic oils are listed below.

The following list is not assumed to be all-inclusive. Hydraulic fluids produced by other manufacturers may be used if they can cross reference to find an equivalent to the products listed. Toro will not assume responsibility for damage caused by improper substitutions, so use only products from reputable manufacturers who will stand behind their recommendation.

| | |
|--------------|--------------------------|
| Manufacturer | ISO VG 46 Multigrade |
| Mobil | DTE 15M |
| Amoco | Rykon Premium ISO 46 |
| Chevron | Rykon Premium ISO Oil 46 |
| Conoco | Hydroclear AW MV46 |
| Exxon | Univis N46 |
| Pennzoil | AWX MV46 |
| Shell | Tellus T 46 |
| Texaco | Rando HDZ 46 |

IMPORTANT: The ISO VG 46 Multigrade fluid has been found to offer optimal performance in a wide range of temperature conditions. For those who prefer them, Universal Tractor Fluids such as Mobilfluid 424 (or equivalent) offer acceptable performance with possibly some loss of efficiency at high ambient temperatures.

Note: Many hydraulic fluids are almost colorless, making it difficult to spot leaks. A red dye additive for the hydraulic system oil is available in 2/3 oz (20 ml) bottles. One bottle is sufficient for 4–6 gal (15–232 l) of hydraulic oil. Order part no. 44–2500 from your authorized Toro distributor. Not recommended for biodegradable fluid (use food coloring).

Biodegradable Hydraulic Fluid – Mobil 224H

IMPORTANT: Mobil EAL 224H is the only biodegradable oil tested and approved by Toro. Contamination by mineral-based hydraulic fluids may change the biodegradability and toxicity of this oil. When changing from standard fluid to the biodegradable type, be certain to follow the approved flushing procedure published by Mobil. Contact your local Toro Distributor for details. This oil is available in 5 gallon (19 l) containers from your Toro Distributor, order part no. 100–7674.

NOTE: Mobil EAL224H and most other hydraulic oils are almost colorless, making it difficult detect leaks. A non-toxic dye additive, such as food coloring, can be added to improve visibility. Do not use hydraulic oil dyes as they may be toxic.

Mobil EAL 224H is available, in 5 gallon containers (Part No. 100–7674) from your local Toro Distributor. If you wish to use an alternate biodegradable and nontoxic hydraulic fluid, first the hydraulic tank, filter, all lines, hoses, motors and pumps must be completely drained to insure that the new oil will fully circulate and coat all components in the hydraulic system, and reduce the chance of gelling or stratifying in certain portions of the circuit. Make sure to replace filter.

NOTE: Be certain that you select an equivalent ISO Viscosity Grade 32/46 hydraulic fluid.

Mixing of hydraulic fluids—Regular petroleum hydraulic fluids, such as Mobil DTE 15 M (Refer to Table) can be added to the system without affecting the performance or life of the components. These mineral based hydraulic fluids and their normal wear additives, even in small quantities, destroys the biodegradability and non-toxicity of the fluid, and the entire system must be considered environmentally hazardous.

1. Position machine on a level surface.
2. Clean area around filler neck and cap of hydraulic tank. Remove cap from filler neck.

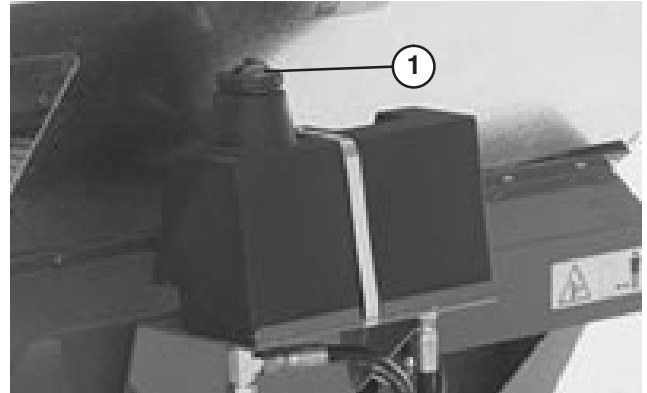

Figure 6

1. Hydraulic Tank Cap

3. Check fluid level. Fluid level should be 1/2 way up screen in filler neck.
4. If level is low, add appropriate fluid to raise level.

Disposal And Spillage

Depending on contamination and/or degradation levels, small amounts of spilled or leaked Mobil EAL224H will not adversely affect ground water or the environment. For small spills on the ground the uncontaminated product will be readily biodegraded by naturally occurring soil organisms when exposed to air. Nonetheless, spillage of Mobil EAL 224H should be handled similarly to currently accepted methods for conventional mineral oil spills.

BEFORE OPERATING

Mobil EAL224H does not contain hazardous substances reportable under CERCLA. Since all oil spills are reportable, even a spill of this vegetable oil-based product must be reported to the National Response Center (the U.S. Coast Guard). Local environmental agencies should also be consulted to clarify local requirements.

Acceptable methods of disposal include use as a fuel supplement, recycling and reclamation (that is, the same disposal practices available for conventional mineral oils). Since Mobil EAL 224H typically will not be hazardous waste, additional disposal options may be available, including land farming or processing through sewage treatment facilities, if necessary approvals are obtained from appropriate authorities.

The flushing solution may not be biodegradable, therefore, it should be disposed of in an environmentally safe manner. Follow procedures used for disposing of conventional mineral oils.

Health And Safety

Based on available toxicological information, Mobil EAL224H produces no significant adverse effects on health when properly handles and used. No special precautions are suggested beyond attention to good personal hygiene, including laundering oil soaked clothing and washing skin contact areas with soap and water. For additional technical information or to order a Material Safety Data Bulletin, call 1-800-662-4525 or www.mobil.com.

CHECK TIRE PRESSURE

The tires are over-inflated for shipping. Therefore, release some of the air to reduce the pressure. Correct air pressure is 20-30 psi.

IMPORTANT: Maintain even pressure in all tires to assure even weight distribution on turf and proper machine performance. DO NOT UNDER INFLATE.

CHECK WHEEL BOLT TORQUE



WARNING

Torque wheel bolts to 80-90 ft-lb after 1-4 hours of operation and again after 10 hours of operation and every 200 hours thereafter. Failure to maintain proper torque could result in failure or loss of wheel.

CONTROLS

GATE METERING CONTROL

The knob and handle on left rear side of machine are used to adjust and lock the gate into the desired open height position.

1. Loosen the adjusting handle enough to allow knob to slide freely in slot.
2. Set the gate into the desired position and tighten the handle to lock into position.

RATE SCALE

Use rate scale to determine desired flow rate. Refer to Sand Application Rate, page 16.

HAND CONTROL SWITCH

Activating hand control switch starts and stops the flow of material from topdresser.

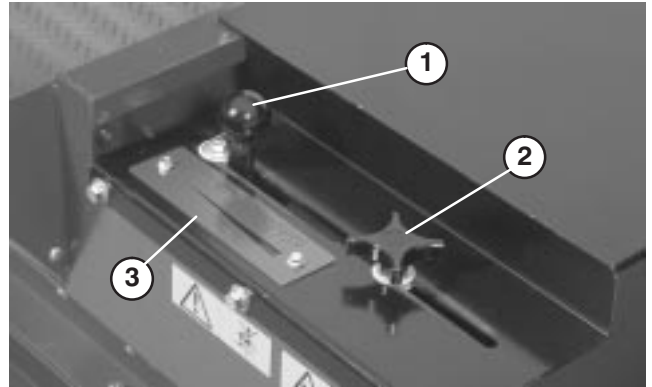

Figure 7

1. Gate adjusting knob & pointer
2. Locking handle
3. Rate scale

OPERATING INSTRUCTIONS

GENERAL

1. The Top Dresser 2500 is ground driven, so it will need to be towed in order to check out operation of belt and brush. Factory checks are performed on a powered roller drum.
2. Top dressing works best at 2 to 8 miles per hour (mph). The TopDresser 2500 compensates for variations in travel speed, and will give consistent distribution, even if travel speed changes during a pass across the green. The operator/superintendent should make a gate setting selection (variable in 1/8 increments to 13) and make a first pass to determine if application rate is acceptable. (see Sand Application Rate, page 16)
3. Operation begins when the hand control switch is activated. This may require some practice to start and stop the flow of material at the desired collar area of the green or tee box.
4. Before loading hopper, make sure topdresser is properly connected to tow vehicle, to prevent flip—up or any unintended tongue movement. **Do Not** unhook topdresser from tow vehicle with material in hopper. Tongue may flip up causing injury.
5. When traveling through narrow areas such as gates, door entries, etc. be aware that topdresser is wider than the tow vehicle. Always check width before proceeding and allow room for clearance to turn.
6. The top dresser adds extra towing weight to the vehicle. Drive the vehicle safely.
 - A. Do not drive on highway or public roads.
 - B. Always SLOW the tow vehicle when approaching and while making a turn.
 - C. Always SLOW the tow vehicle when driving in unfamiliar areas or over rough terrain.
 - D. Always SLOW the tow vehicle when changing direction of travel or preparing to stop.
 - E. When turning or driving on slopes, always SLOW the tow vehicle, then turn to prevent loss of control and possible upset.
 - F. **DO NOT** make sudden or sharp turns. **DO NOT** suddenly change direction of travel on an incline, ramp, grade, slope or similar surface.
 - G. Always adjust the tow vehicle speed to allow for existing ground conditions such as wet slick surfaces, loose sand or gravel and/or low visibility conditions such as dim or bright lighting, fog, mist or rain.
 - H. Be especially careful when driving a heavily loaded vehicle down an incline or slope. Drive the vehicle UP and DOWN the face of the slopes,

inclines or grades whenever possible. **DO NOT DRIVE** across the face if at all possible. There is a risk of upsetting the vehicle, which can result in serious injury or death.



WARNING

Tipping or rolling the tow vehicle on a hill will cause serious injury.

If engine stalls or you lose headway on a hill, never attempt to turn tow vehicle around.

Always back straight down a hill in reverse gear.

NEVER back down in neutral or with the clutch depressed, using only the brakes.

NEVER add sideboards or panels to the top of the hopper to increase the load capacity. The additional weight will cause tipping or rolling of the tow vehicle and lead to serious injury.

NEVER drive across a steep hill, always drive straight up or down. Avoid turning on a hill. Don't "drop the clutch" or slam on the brakes. Sudden speed change can initiate tipover.

7. In tight areas, where a straight line pass across a green is not possible, the TopDresser2500 can be backed onto the area without harm and begin topdressing when pulling forward. See the hydraulics section for more information on the special features of the Top Dresser 2500.
8. Before backing up, look to the rear and assure no one is behind. Back up slowly and watch the top dresser movement closely.
9. Use extreme caution and slow speed when backing up the top dresser and tow vehicle.
10. The maximum recommended towing speed is 15 mph (Loaded 8 mph). As with any trailer, always use caution when turning or backing up. Be aware of persons or objects near the topdresser path of travel.
11. Watch out for traffic when near or crossing roads. Always yield the right of way to pedestrians and other vehicles.
12. If the top dresser begins to vibrate abnormally, stop immediately. Shut off the tow vehicle engine. Repair all damage before commencing towing.
13. If cavitation noise is heard while transporting across the golf course, slow down, return to maintenance, and investigate the cause. Do not exceed the 15 mph tow speed. This unit was not designed for travel on highways. Damage will occur to the internal hydraulic components.

OPERATING INSTRUCTIONS

14. Before servicing or making any adjustments to the top dresser:

- A. Stop the tow vehicle and set the parking brake.
- B. Shut off the tow vehicle's engine and remove key from ignition.

15. Keep all nuts, bolts and other fasteners tightened securely. Replace any parts removed during servicing or adjustments.

16. When loading the top dresser mix into the hopper, be careful that the loader or skid steer bucket does not strike and buckle the hopper sides. Although designed to be wide enough to clear most buckets, it is not strong enough to take a direct hit and may deform the sheet metal.

17. Dispersion is always best with dry material, but wet sand can be spread with the special traction grip belt on the Top Dresser 2500. Some adjustment to the gate setting may be required, but the material should flow out and spread relatively smooth and consistent. If any slippage of the belt appears to be occurring, check the Maintenance section; Belt adjustment and clean-out provisions.

18. Top-dress mix can vary in grain size as well as moisture. It can also contain impurities that may either damage greensmowers or plant tissue. Always control the source of top-dress material, and use care when handling and loading.

19. A sight window is provided on the right front hopper panel to monitor remaining material while topdressing. It is good practice to glance over your right shoulder and check the hopper volume before beginning application to assure that you don't run out in the middle of a pass.

20. The special oscillating drive axles on the Top Dresser 2500 were designed to continue powering the hydraulics while traversing over undulations and irregularities in the surface of the green or tee. Always approach severe berms slowly to avoid sudden impact of the axles with the turf, and to reduce the potential of leaving tire marks on the approach to the green.



WARNING

Rotating parts can grab or pinch. Stay clear of brush and conveyor belt while unit is running.

Safe operation begins before taking the top dresser out for a day's work. Read and understand the operating instructions in the Toro Workman or other tow vehicle operator's manual before using the topdresser.



CAUTION

The interlock switches are for the operator's protection, so do not bypass them. Check operation of the switches daily to assure interlock system is operating on the Workman. If a switch is malfunctioning replace it before operating. Regardless whether switches are operating properly or not, replace them every two years to assure maximum safety. Do not rely entirely on safety switches – use common sense!

OPERATION

1. Sit on operator's seat and engage tow vehicle parking brake.
2. Disengage PTO (if so equipped) and return hand throttle lever to OFF position (if so equipped).
3. Move shift lever to NEUTRAL position and depress clutch lever.
4. Insert key into ignition switch and rotate it clockwise to start the engine. Release key when engine starts.
5. Practice starting, driving and stopping the tow vehicle. Always read and understand the operator's manual for the tow vehicle before using this unit.
6. Check for smooth operation of belt before adding material in hopper.
7. Place sand or other topdressing material in the hopper. The maximum volume of material that can be put into the hopper is 25 cubic feet. Generally, sand weighs 100 pounds per cubic foot and could overload the unit if more than 2050 pounds are loaded into the hopper.
IMPORTANT: Overloading can result in side wall deflection of tires and marking of green on first few passes. Check tire pressures – Recommended pressure is 20 – 30 p.s.i. max.
8. Transport to the area to be top-dressed.
9. Adjust the metering gate to the desired rate. Lock into position with the black knob.
10. For best results, move the shift lever into "LO" range position. Select the desired forward speed and begin moving. Refer to the following section, Sand Application Rate.

OPERATING INSTRUCTIONS



DANGER

As a general rule, position the weight of the load evenly from front to rear and evenly from side to side.

Transporting or topdressing with a full load can cause shifting of the sand. This shifting happens most often while turning, going up or down hills, suddenly changing speeds or while driving over rough surfaces. Shifting loads can lead to tipovers. Use caution when transporting or topdressing with a full load.

Heavy loads increase stopping distance and reduce your ability to turn quickly without tipping over.

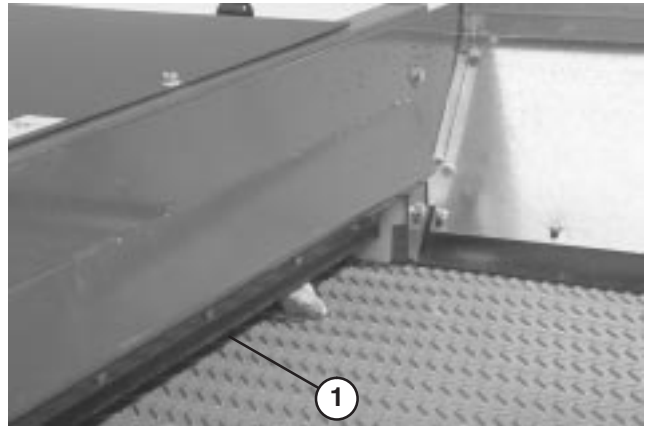

Figure 8

1. Gate edge

SAND APPLICATION RATE

The rate of sand applied depends on the gate setting. Sand varies in moisture and coarseness (size of grain) which effects the rate. These factors must be taken into consideration when deciding the amount of sand required for the application. Test a small area to decide the correct amount. To increase application rate open gate to a higher scale mark.

The TopDresser 2500 is ground driven which assures consistent application, from green to green, when towing speed is within the recommended 2–8 mph..

SAND PRECAUTIONS

The TopDresser 2500 is equipped with a flexible gate edge (Fig. 8) and spring release mechanism to reduce the chance of sand chunks or rocks getting lodged during operation. To insure long belt life, sift or check sand for rocks with sharp edges that may damage conveyor belt.

COLD WEATHER OPERATION

Although limited by traction of drive tires, the Topdresser 2500 may be used in cold weather, with certain limitations, to apply a salt/sand mixture on pavement for ice control. The PVC conveyor belt material becomes very stiff in cold weather and requires more power to operate belt. The life of the belt is reduced by approximately 50% when operated below temperatures of 40° F (5° C). **Under no conditions should the topdresser be operated below temperatures of 20° F (–7° C).**

1. Increase belt tension by adjusting spring compression to 4 inches (101 mm). Refer to Adjusting Conveyor Belt, page 20.

2. **Always run belt, before adding material, to assure moisture has not frozen belt system. Damage to belt or roller may occur if belt/drive roller slip.**

IMPORTANT: Always re–set belt tension to normal 4–7/16” (112 mm) spring compression adjustment before operating topdresser under normal temperature conditions.

LUBRICATION

GREASING BEARINGS

The Topdresser 2500 has 13 grease fittings that must be lubricated with a No. 2 Lithium based grease. Lubricate annually or after every 200 hours of operation.

The grease fitting locations and quantities are: Roller shaft bearings (4) (Fig. 9), Brush shaft bearing (1) (Fig. 9), Pivot bearings (4) (Fig. 10) and Wheel bearings (4) (Fig. 10).

IMPORTANT: Lubricate the bearings to maintain a slight leakage between bearings and housings. Too much grease can cause overheating or damage to seals.

NOTE: We do not recommend lubricating the drive chains unless they become stiff because of rust. If the chain rusts, it may be lubricated lightly with a DRY-TYPE LUBRICANT. This will reduce the chance for build-up of sand or other topdress material on chain.



Figure 9

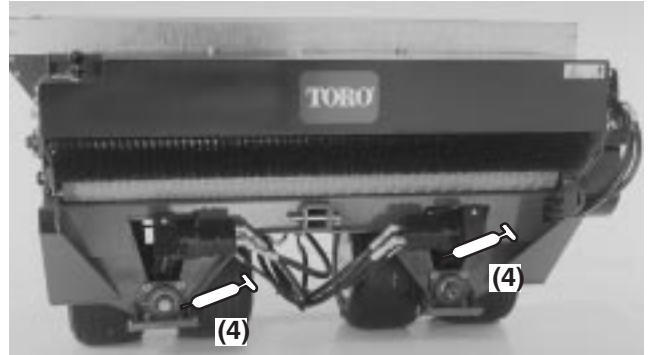

Figure 10

MAINTENANCE

JACKING TOPDRESSER

1. The jacking points on the topdresser are the skids.
2. Any load material must be removed from hopper before working under raised topdresser.
3. Do not work under topdresser without jack stands supporting it.
4. Pivot wheels up or down to expose wheel bolts.



WARNING

If wheels are removed and re-installed, make sure to torque wheel bolts to 80-90 ft-lb . Failure to maintain proper torque could result in failure or loss of wheel.

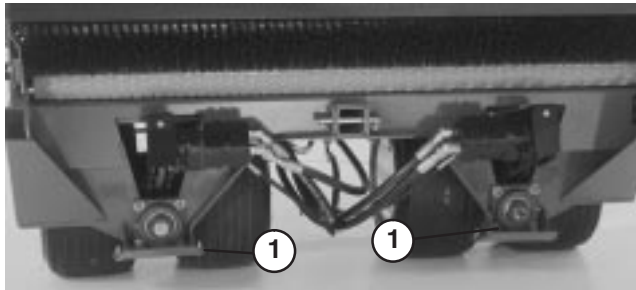

Figure 11
1. Skid (4)

CHANGING HYDRAULIC FLUID

Change hydraulic fluid after annually or every 200 operating hours, in normal conditions. If fluid becomes contaminated, contact your local TORO distributor because the complete system must be drained. Contaminated fluid looks milky or black when compared to clean oil.

1. Position machine on a level surface.
2. Remove fitting from bottom of reservoir and let hydraulic fluid flow into drain pan. Reinstall and tighten fitting when hydraulic fluid stops draining.

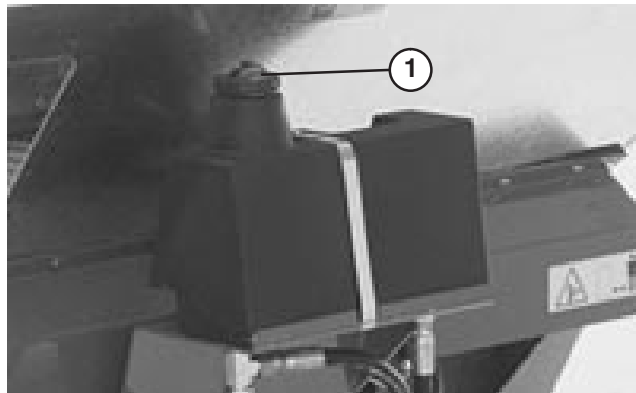

Figure 12
1. Hydraulic Tank Cap

3. Fill reservoir with approximately 2.5 gallons (9.5 l) of hydraulic fluid. Refer to Checking Hydraulic Fluid.

IMPORTANT: Use only hydraulic fluids specified. Other fluids could cause system damage.

4. Check level of fluid and add enough to raise to proper level. **DO NOT OVER FILL.** Refer to Checking Hydraulic Fluid.
5. Install reservoir cap.

REPLACING HYDRAULIC FILTER

Change hydraulic filter annually or after every 200 operating hours, in normal conditions.

Use the Toro replacement filter (Part No. 86-3010).

IMPORTANT: Use of any other filter may void the warranty on some components.

1. Position machine on a level surface.
2. Clean area around filter mounting area. Place drain pan under filter and remove filter.

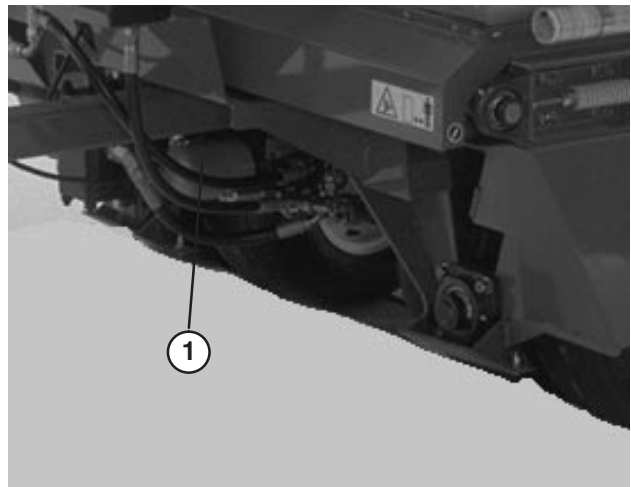

Figure 13
1. Hydraulic Filter

3. Lubricate new filter gasket.
4. Assure filter mounting area is clean. Screw filter on until gasket contacts mounting plate. Then tighten filter one-half turn.
5. Check for leaks by towing machine to power the hydraulic system.

CHECKING HYDRAULIC LINES AND HOSES

Inspect hydraulic lines and hoses daily for leaks, kinked lines, loose mounting supports, wear, loose fittings, weather deterioration and chemical deterioration. Make all necessary repairs before operating.

MAINTENANCE



WARNING

Keep body and hands away from pin hole leaks or nozzles that eject high pressure hydraulic fluid. Use cardboard or paper to find hydraulic leaks. Hydraulic fluid escaping under pressure can penetrate skin and cause injury. Fluid accidentally injected into the skin must be surgically removed within a few hours by a doctor familiar with this form of injury or gangrene may result.

BRUSH ADJUSTMENT

Brush must make enough contact with conveyor belt to disperse topdressing material but not restrict the rotation of the brush. A piece of stiff paper can be inserted between the conveyor belt and the brush to check the adjustment. The brush must be the same height from side to side. The brush adjustment should be checked weekly for wear. The bristles of the brush will wear under normal conditions and the distance from the brush to conveyor belt should be maintained to prevent uneven wear of the brush.

NOTE: If using moist top dressing materials, brush may have to be adjusted so bristles will whisk material from between conveyor belt lugs without severely contacting smooth portion of belt.

1. Loosen nuts securing bearing housing (Fig. 14) to right side of machine.

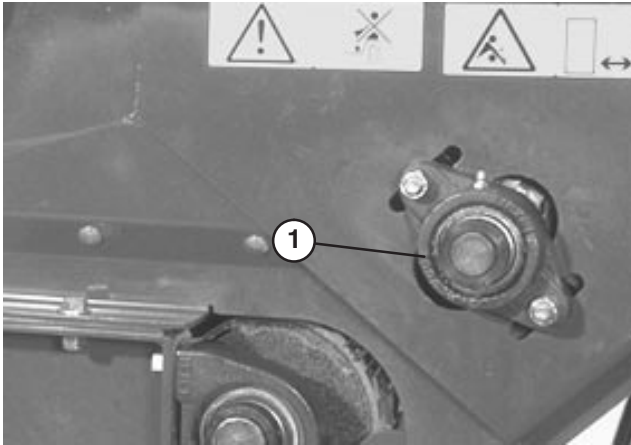

Figure 14

1. Bearing housing

2. Loosen nuts securing brush motor (Fig. 15) to left side of machine.

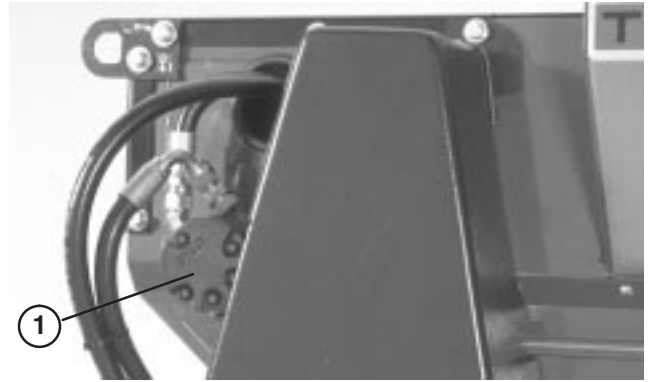

Figure 15

1. Brush motor

3. Slide brush into position on right side. Finger tighten nuts.
4. Slide brush into position on left side. Finger tighten nuts.
5. Insert a piece of stiff paper between the brush and the conveyor belt. The brush must be the same height from side to side.
6. If the adjustment is correct, tighten nuts. If not, repeat procedure.

TENSIONING DRIVE CHAINS

The chains should be tensioned so they deflect 1/8". Do not over tighten, this will cause chain wear. Do not operate with a loose chain, this will cause sprocket wear.

Conveyor Belt Chain

1. Remove chain cover (Fig. 16).

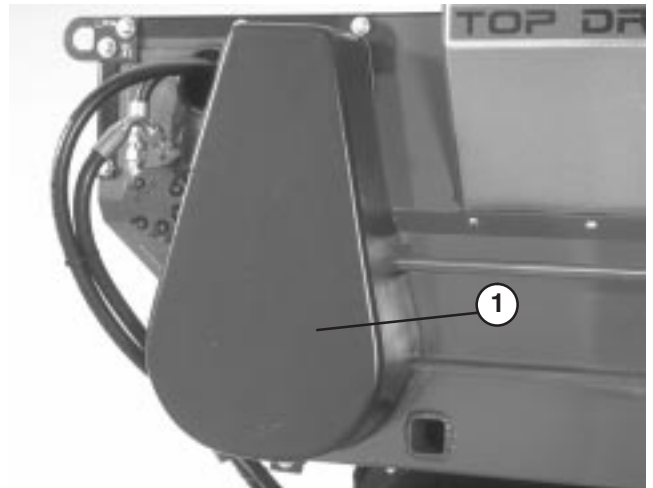

Figure 16

1. Chain cover

2. Loosen bolts and nuts securing motor and sprocket assembly to the main frame (Fig. 17).
3. Rotate motor and sprocket assembly, in mounting slots, until proper tension is achieved.

MAINTENANCE

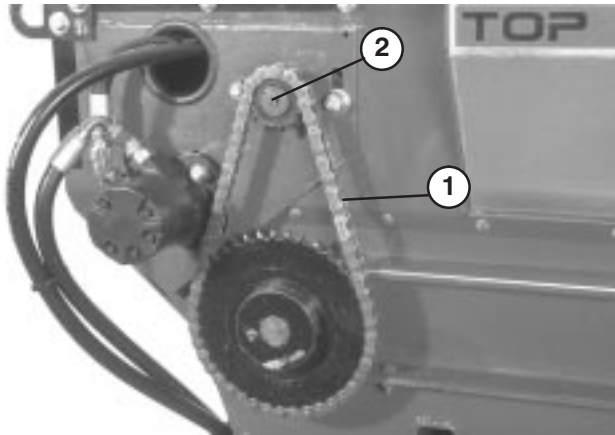

Figure 17

1. Drive chain
2. Motor & sprocket assembly

4. Tighten mounting bolts.

5. Install chain cover.

Wheel Drive Chain

1. Loosen carriage bolts and nuts securing hydraulic motor/pump to axle cradle (Fig. 18).

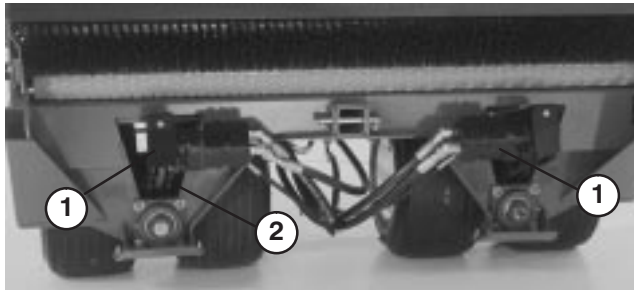

Figure 18

1. Hydraulic motor
2. Axle cradle cut-out

2. Rotate motor sprocket assembly until proper chain tension is attained.

NOTE: Access to chain is thru cut out in lower side of axle cradle.

3. Tighten mounting bolts.

NOTE: We do not recommend lubricating the drive chains unless they become stiff because of rust. If the chain rusts, it may be lubricated lightly with a DRY-TYPE LUBRICANT. This will reduce the chance for build-up of sand or other topdress material on chain.

ADJUSTING CONVEYOR BELT

When conveyor belt is adjusted properly, the compressed length of each compression spring should be 4–7/16" (112 mm). Adjust conveyor belt as follows:

1. Loosen jam nuts and adjust tension rod nuts to attain desired tension.

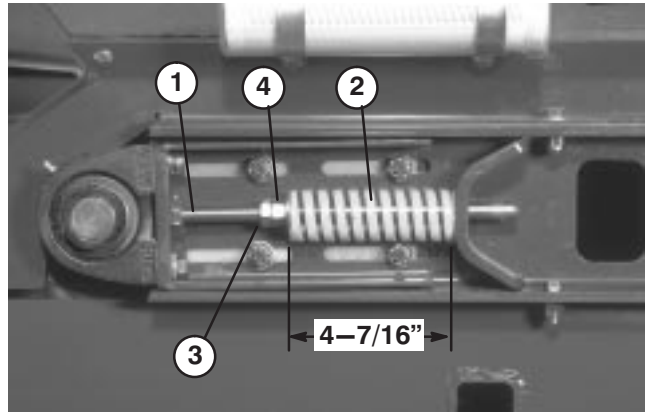

Figure 19

1. Tension rod
2. Compression spring
3. Jam nut
4. Nut

2. Tighten jam nuts to lock adjustment.

3. Check to insure that the center distance between conveyor belt roller shafts (Fig. 20), on each side of machine, are equal distance (approximately 35–1/4").

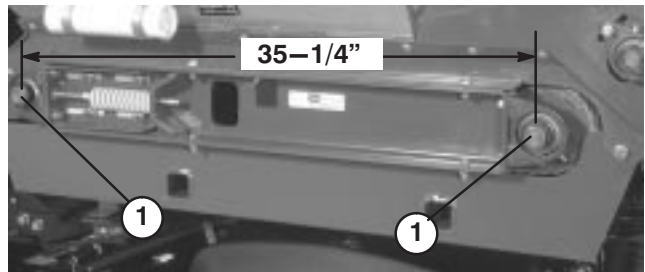

Figure 20

1. Conveyor belt roller shafts

REPLACING CONVEYOR BELT

When replacing a damaged or worn conveyor belt, always inspect hopper seals (Fig. 21) and gate edge (Fig. 21) for wear or torn edges. Replace worn or torn components to insure proper operation of new conveyor belt.

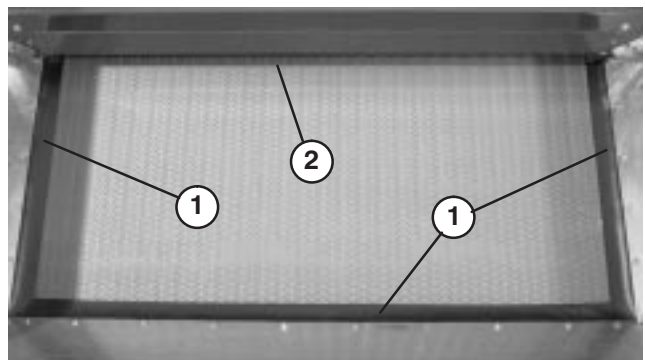

Figure 21

1. Hopper seal
2. Gate edge

1. Remove chain cover (Fig. 22).

MAINTENANCE

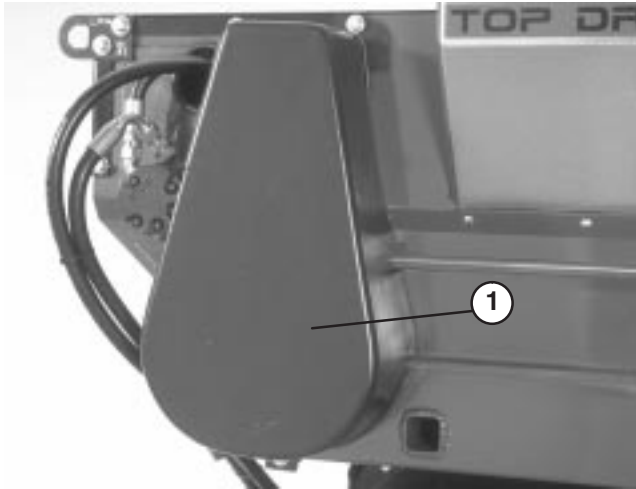

Figure 22
1. Chain cover

2. Remove master link from chain and remove chain from small sprocket (Fig. 23).

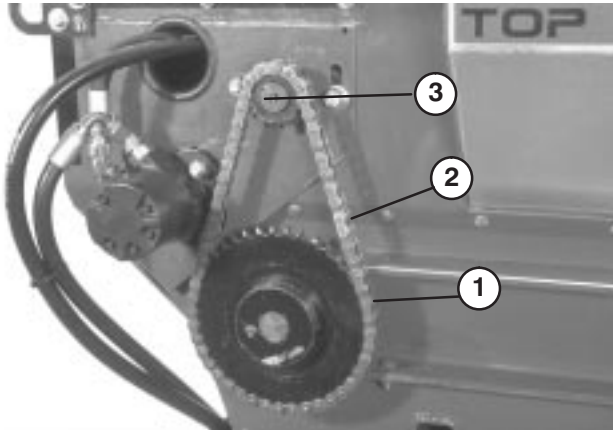

Figure 23
1. Drive chain
2. Master link
3. Motor

Note: Motor mounting bolts may have to be loosened to disassemble chain link.

3. Loosen jam nuts and nuts on tension rod to release spring tension (Fig. 24).

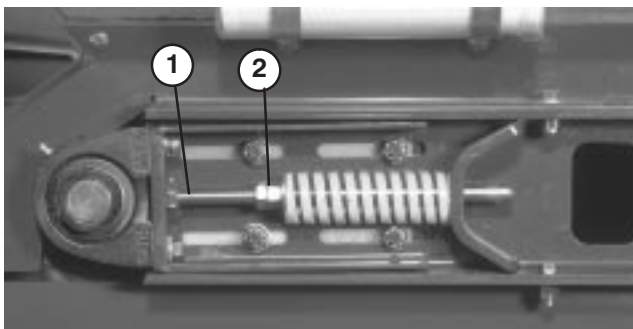

Figure 24
1. Tension rod
2. Nuts

4. Remove (2) capscrews, washers and nut, on each side of machine, securing hopper to slider bed (Fig. 25).

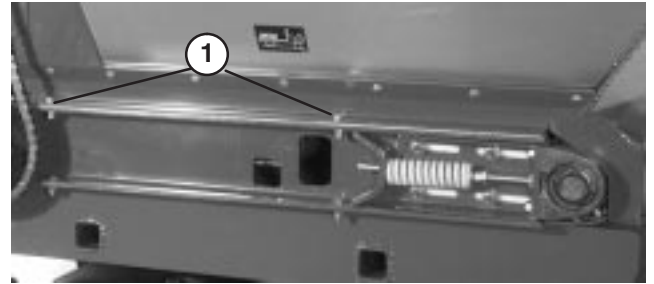

Figure 25
1. Hopper mounting capscrews
(Right side shown)

5. Pivot hopper rearward and lean against wall, ladder, etc. Do not allow hopper to rest against rear of machine as damage may result to brush or hydraulic couplers (Fig. 26).

IMPORTANT: Make sure hopper is pivoted beyond center and/or secured to wall or post to prevent it from accidentally falling on work area (Fig. 26).

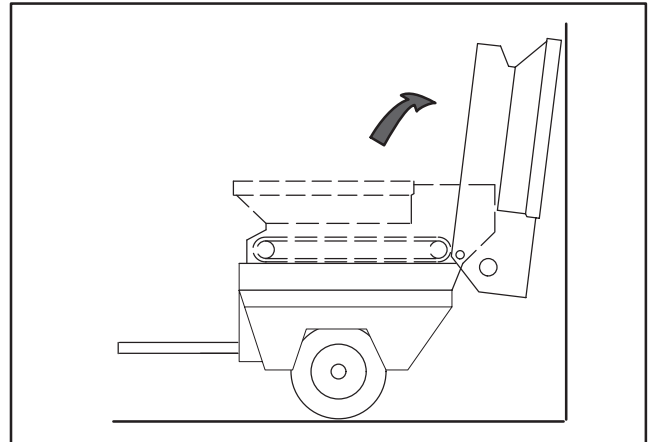

Figure 26

6. Loosen (2) capscrews, washers and nut, on right side of machine, securing slider bed to frame (Fig. 27). Make sure fasteners are loose enough to allow slider bed to be tipped.

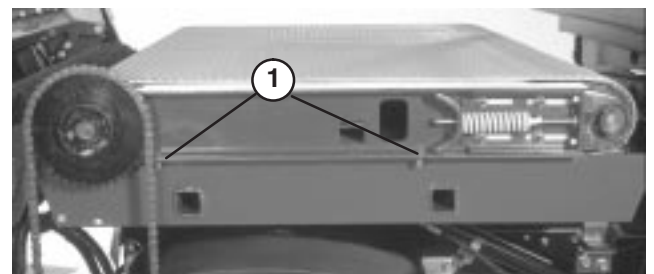

Figure 27
1. Slider bed mounting capscrews

7. Remove (2) capscrews, washers and nut, on left side of machine, securing slider bed to frame (Fig. 28).

MAINTENANCE

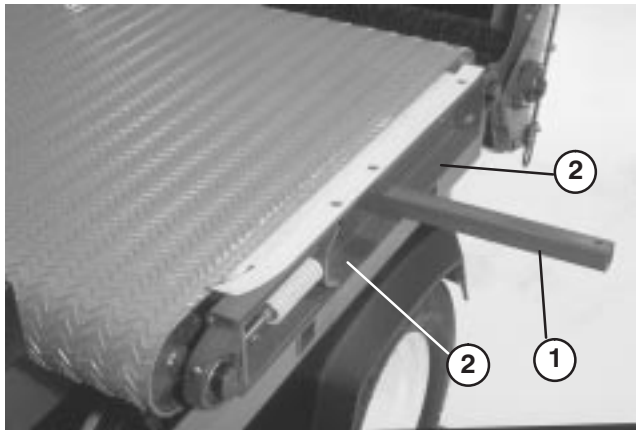

Figure 28

1. Lifting rod
2. Slider bed mounting capscrews

8. To remove belt:
 - A. Cut belt and remove from rollers
or
 - B. Insert a plastic belt tool between each roller and belt. Rotate rollers until each tool is positioned to the outside of each roller. Tool must be inserted past rib in center of belt.
 - C. Insert a lift bar into hole on left side of machine.
 - D. Raise lift bar to tip slider bed.
 - E. Slide belt and belt tools off the rollers at the same time.
9. To install belt:
 - A. Insert a lift bar into hole on left side of machine and raise lift bar to tip slider bed (Fig. 28).
 - B. Insert belt onto rollers as far as possible.
 - C. Insert a plastic belt tool between each roller and belt. Rotate rollers until each tool is positioned to the outside of each roller. Tool must be inserted past rib in center of belt.
 - D. Slide belt and belt tools onto rollers until belt is approximately centered on rollers.
 - E. Remove belt tools from between belt and rollers.
 - F. Position belt so rib fits into alignment grooves in each roller.
 - G. Reverse procedure to re-assemble hopper and chain components.
 - H. Adjust belt. Refer to Adjusting Conveyor Belt, page 20.

HYDRAULIC SYSTEM DIAGNOSTICS

Flow Rates and Performance Checks – Since the Top Dresser 2500 uses ground driven hydraulics, it is necessary to tow the unit to do these performance tests. Rather than using a flow meter to measure hydraulic circuit flow, an approximation can be determined by measuring the brush speed with a rotating contact RPM indicator. See table for flow rate values.

HYDRAULIC FLOW RATES AND SPEED TABLE

| Wheel Speed (mph) | Brush RPM | Approximate System Flow (gpm) |
|-------------------|-----------|-------------------------------|
| 2 | 160–180 | 1.8 |
| 3 | 245–270 | 2.7 |
| 4 | 325–360 | 3.6 |
| 5 | 405–450 | 4.5 |
| 6 | 485–540 | 5.4 |
| 7 | 570–635 | 6.3 |
| 8 | 650–725 | 7.2 |

Charge Pressure – To provide oil to the inlets of the wheel drive pumps, a self-generating charge pump is used. A pressure port (P2) is provided to measure the output and charge relief. While towing the unit at over 3 to 5 mph, the pressure should be at least 50–60 psi. Possible cause of low charge pressure would include; clogged oil filter, low reservoir, or air in the drive pump circuit.

System Pressure – The main hydraulic system pressure can be measured at the port provided (P1). The relief is set to 1500psi and can be checked while towing the unit with the brakes activated. If the optional brake solenoid is not on the your topdresser, the pressure in the belt/brush circuit will be the next choice, but typically the pressure will not be at relief.

Special Check Valves and Circuit Features – The Top Dresser 2500 hydraulic mono-block valve contains several special performance enhancement features. In order to back the unit into parking spaces, or while backing on to difficult access approaches to greens for example, the hydraulic circuit needs a reversing check valve to prevent back-flushing the filter or harming the charge pump circuit. The unit will not operate any functions when backing up, as the oil is just re-circulating in the wheel pump circuit.

MAINTENANCE

Bleeding and Priming of Hydraulic System –

Bleed/drain lines are provided for the drive pumps and belt motor. This helps purge the system of air, hot oil and to circulate clean oil into the hydraulic drive loops. An auto-fill line runs from the reservoir to a special port at the control module with a low resistance check valve. If an air lock has occurred (maybe caused by partial drainage during dis-assembly), it may be necessary to crack open the highest point hydraulic line near the brush motor, while slowly towing the unit, to purge air from the closed circuit.

Oil Filter – Change the oil filter annually or every 200 operating hours to insure the cleanliness of hydraulic fluid and to protect the functional performance and durability of the other hydraulic components.

Solenoids – A 12 volt electrical signal is required to activate the electro/hydraulic solenoid that controls the circuit for top-dress belt and brush motors. If the belt

and brush fail to turn on when the hand control is activated, always check the 12 volt power supply and fuse first. Then using a voltmeter, check for 12 volts at the solenoid wire connector. Check for resistance in the coil and inspect/replace if it is open circuited. If all these previous checks do not correct the problem, there may be dirt in the solenoid, and it will need to be dis-assembled and inspected.

Trailer Brakes – Warning! Hydraulic trailer brakes may overheat the fluid in the hydraulic circuit if the brakes remain activated continuously. The system is using an electrical solenoid that causes the wheel pump to run over relief, which slows/retards the topdresser. Since energy (hydraulic heat) is related to travel speed, using the brakes continuously on long down hill roads could significantly heat the hydraulic oil. Always use a lower speed gear selection when descending long hills. Activate the brakes intermittently to allow for cooling cycles for both the vehicle and the topdresser.

TROUBLE SHOOTING

A. Difficulty in connecting or disconnecting control wires:

- Wrong connector on tow vehicle. An additional harness may be acquired from your distributor.
- On/off connections switched with brake wiring.

B. Topdresser hard to pull with tow vehicle:

- Wheel motors (pumps) not turning.
- Plumbing reversed.
- Brake solenoid activated (check wiring).
- Hydraulic oil hot.

C. Hydraulic leaks:

- Fittings loose.
- Oil filter loose.
- Fitting missing o-ring.
- Reservoir over filled.

D. Belt and/or brush does not function:

- Solenoid wiring not providing 12 volts – Check fuse and connections
- Control handle toggle switch malfunction – Check for continuity and check diode in electrical solenoid connector.
- Hydraulic motors (pumps) not turning, check chain drive.
- Belt Slipping—Check tension

E. Belt tracking:

- Check rollers for even center distance (side to side)
- Check belt tension (spring compressed equally on each side)
- Bearing lock collars securing roller not tight.
- Belt guide groove not aligned with roller

HYDRAULIC SCHEMATIC

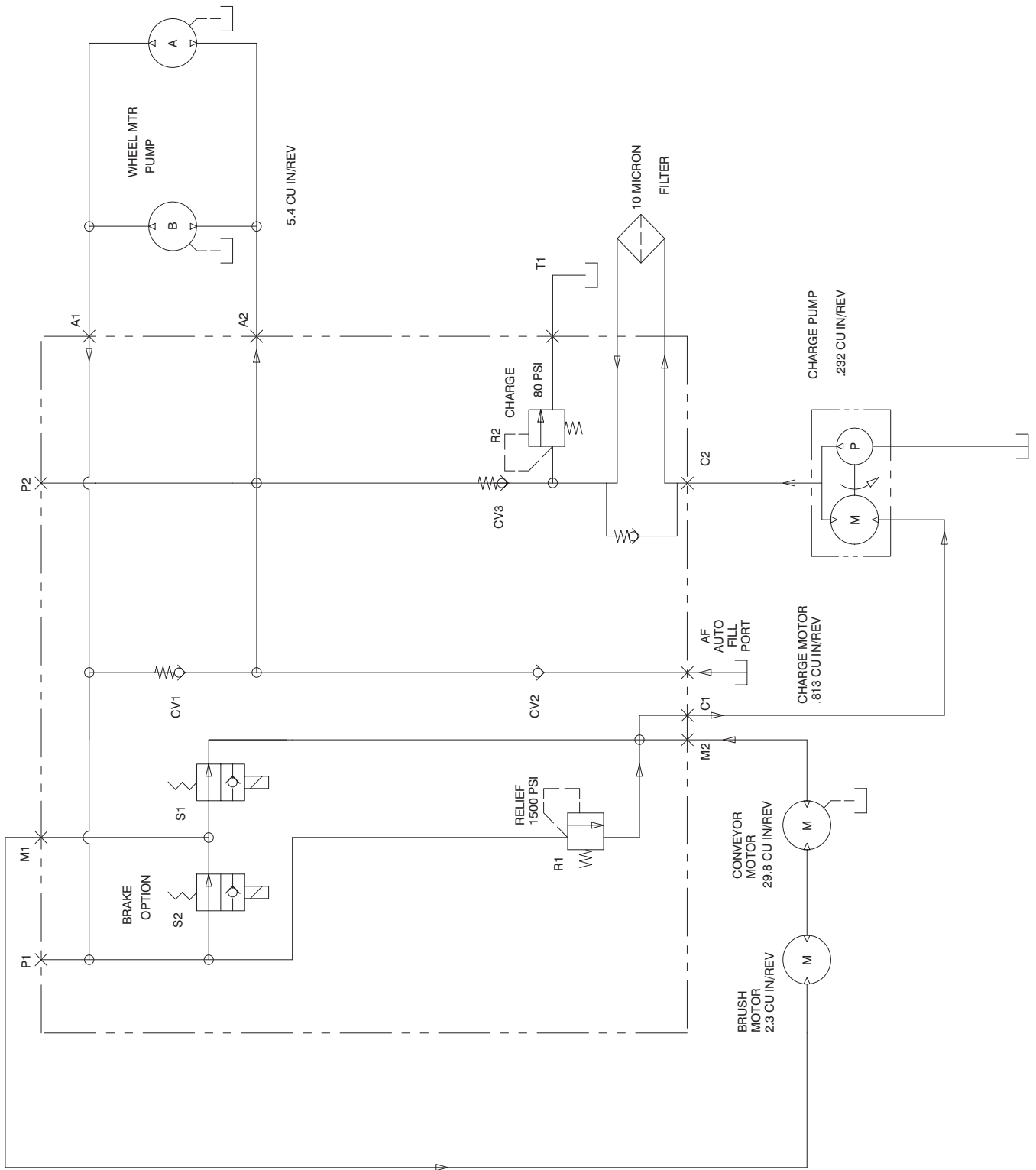

ELECTRICAL SCHEMATIC

S1

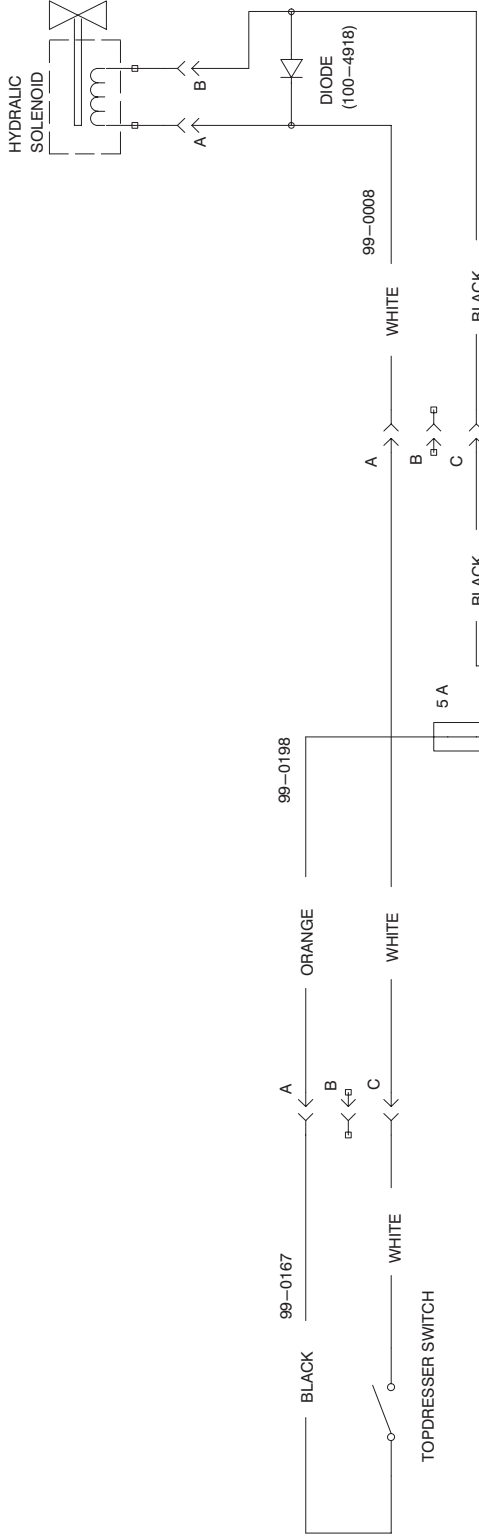

S2

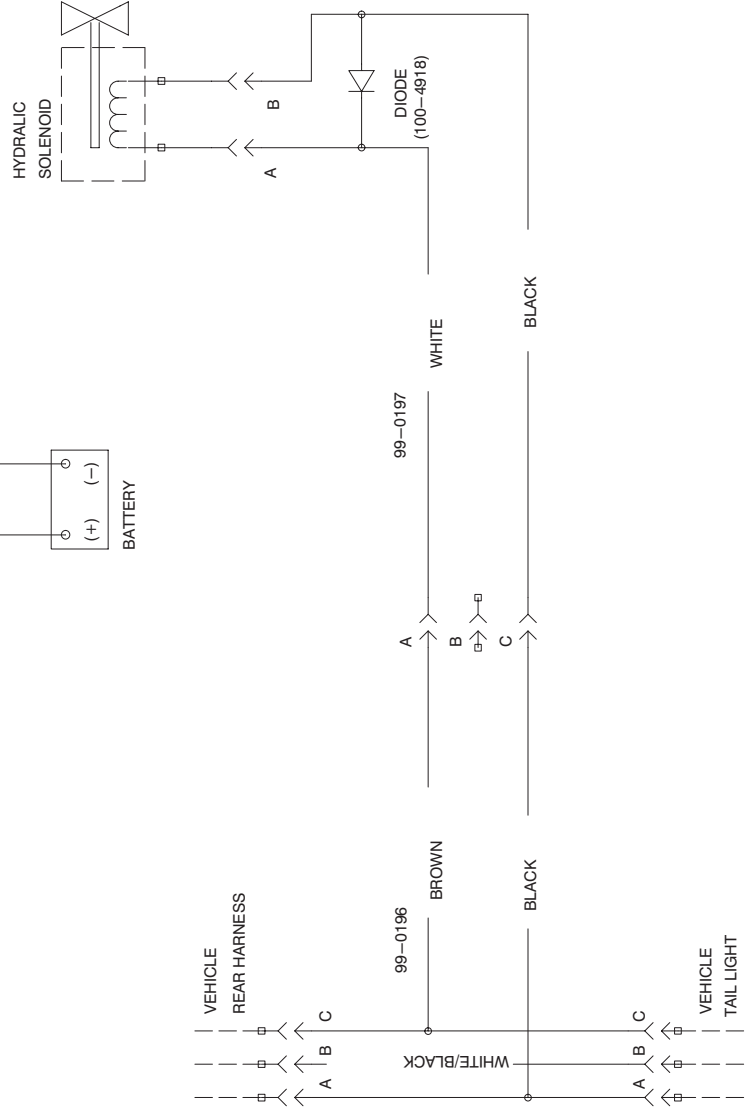

SEASONAL STORAGE

Thoroughly clean the topdresser, especially inside the hopper. The hopper and conveyor belt area should be free of any remaining sand particles.

1. Tighten all fasteners.
2. Lubricate all grease fittings and bearings. Wipe off excess lubricant.
3. The unit should be stored out of the sun to prolong the life of the conveyor belt. When stored outside it is recommended to cover the hopper with a tarp.
4. Check the tension of the drive chain. Adjust the tension, if necessary.
5. Check the tension of the conveyor belt. Adjust the tension, if necessary.
6. When bringing topdresser out of storage, check for smooth operation of belt before adding material in hopper.

IDENTIFICATION AND ORDERING

MODEL AND SERIAL NUMBERS

The Topdresser 2500 has two identification numbers: a model number and a serial number. These numbers are stamped into a plate located on left side of slider frame (Fig. 29).

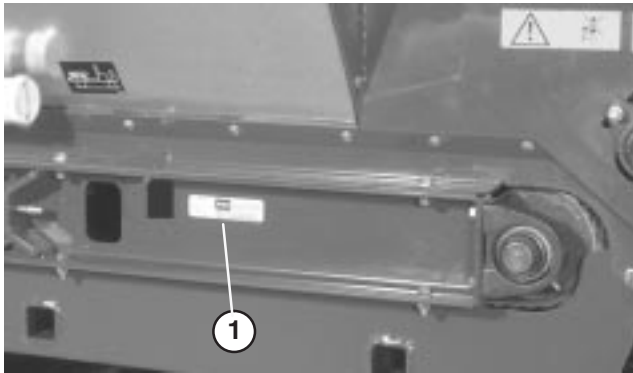

Figure 29

1. Model and serial number

To order replacement parts from an authorized TORO Distributor, supply the following information:

1. Model and serial numbers of the machine.
2. Part number, description and quantity of parts desired.

Note: Do not order by reference number if a parts catalog is being used; use the part number.



The Toro General Commercial Products Warranty

A Two-Year Limited Warranty

Conditions and Products Covered

The Toro Company and its affiliate, Toro Warranty Company, pursuant to an agreement between them, jointly warrant your 1996 or newer Toro Commercial Product ("Product") purchased after January 1, 1997, to be free from defects in materials or workmanship for two years or 1500 operational hours*, whichever occurs first. Where a warrantable condition exists, we will repair the Product at no cost to you including diagnosis, labor, parts, and transportation. This warranty begins on the date the Product is delivered to the original retail purchaser.

* Product equipped with hour meter

Instructions for Obtaining Warranty Service

You are responsible for notifying the Commercial Products Distributor or Authorized Commercial Products Dealer from whom you purchased the Product as soon as you believe a warrantable condition exists.

If you need help locating a Commercial Products Distributor or Authorized Dealer, or if you have questions regarding your warranty rights or responsibilities, you may contact us at:

Toro Commercial Products Service Department
Toro Warranty Company
8111 Lyndale Avenue South
Bloomington, MN 55420-1196
952-888-8801 or 800-982-2740
E-mail: commercial.service@toro.com

Owner Responsibilities

As the Product owner, you are responsible for required maintenance and adjustments stated in your operator's manual. Failure to perform required maintenance and adjustments can be grounds for disallowing a warranty claim.

Items and Conditions Not Covered

Not all product failures or malfunctions that occur during the warranty period are defects in materials or workmanship. This express warranty does not cover the following:

- Product failures which result from the use of non-Toro replacement parts, or from installation and use of add-on, modified, or unapproved accessories
- Product failures which result from failure to perform required maintenance and/or adjustments
- Product failures which result from operating the Product in an abusive, negligent or reckless manner
- Parts subject to consumption through use unless found to be defective. Examples of parts which are consumed, or used up, during normal Product operation include, but are not limited to, blades, reels, bedknives, tines, spark plugs, castor wheels, tires, filters, belts, etc.

Countries Other than the United States or Canada

Customers who have purchased Toro products exported from the United States or Canada should contact their Toro Distributor (Dealer) to obtain guarantee policies for your country, province, or state. If for any reason you are dissatisfied with your Distributor's service or have difficulty obtaining guarantee information, contact the Toro importer. If all other remedies fail, you may contact us at Toro Warranty Company.

- Failures caused by outside influence. Items considered to be outside influence include, but are not limited to, weather, storage practices, contamination, use of unapproved coolants, lubricants, additives, or chemicals, etc.
- Normal "wear and tear" items. Normal "wear and tear" includes, but is not limited to, damage to seats due to wear or abrasion, worn painted surfaces, scratched decals or windows, etc.

Parts

Parts scheduled for replacement as required maintenance are warranted for the period of time up to the scheduled replacement time for that part.

Parts replaced under this warranty become the property of Toro. Toro will make the final decision whether to repair any existing part or assembly or replace it. Toro may use factory remanufactured parts rather than new parts for some warranty repairs.

General Conditions

Repair by an Authorized Toro Distributor or Dealer is your sole remedy under this warranty.

Neither The Toro Company nor Toro Warranty Company is liable for indirect, incidental or consequential damages in connection with the use of the Toro Products covered by this warranty, including any cost or expense of providing substitute equipment or service during reasonable periods of malfunction or non-use pending completion of repairs under this warranty. Except for the Emissions warranty referenced below, if applicable, there is no other express warranty. All implied warranties of merchantability and fitness for use are limited to the duration of this express warranty.

Some states do not allow exclusions of incidental or consequential damages, or limitations on how long an implied warranty lasts, so the above exclusions and limitations may not apply to you.

This warranty gives you specific legal rights, and you may also have other rights which vary from state to state.

Note regarding engine warranty: The Emissions Control System on your Product may be covered by a separate warranty meeting requirements established by the U.S. Environmental Protection Agency (EPA) and/or the California Air Resources Board (CARB). The hour limitations set forth above do not apply to the Emissions Control System Warranty. Refer to the Engine Emission Control Warranty Statement printed in your operator's manual or contained in the engine manufacturer's documentation for details.