



Form No. 3458-392 Rev B

Count on it.

Operator's Manual

**Pro Force® Debris Blower
Groundsmaster® 3200 or 3300 Series
Traction Unit**

Model No. 31916—Serial No. 410200000 and Up



Contents

Safety	3
General Safety	3
Safety and Instructional Decals	3
Setup	5
1 Removing the Blower from the Crate	6
2 Installing the Mounting Plate to the Debris Blower Frame	7
3 Preparing the Traction Unit	8
4 Mounting the Debris Blower to the Traction Unit	9
5 Installing the Jack Stand to the Storage Tube.....	10
6 Installing the Whip Guides.....	10
7 Greasing the Machine.....	11
Operation	12
Operation Safety	12
Adjusting the Blower Nozzle Height	13
Operating Tips	14
Maintenance	15
Maintenance Safety.....	15
Lubricating the Blower	15
Lubricating the Driveshaft.....	16
Checking the Gearbox Lubrication.....	17
Checking the Nozzle.....	17
Adjusting the Nozzle Belt.....	18
Storage.....	19

Safety

General Safety

This product is capable of amputating hands and feet and throwing objects. Always follow all safety instructions to avoid serious personal injury.

- Read and understand the contents of both this *Operator's Manual* and the operator's manual of the traction unit before using this machine. Ensure that everyone using this product knows how to use this machine and the traction unit and understands the warnings.
- Use your full attention while operating the machine. Do not engage in any activity that causes distractions; otherwise, injury or property damage may occur.
- Do not put your hands or feet near moving components of the machine.
- Do not operate the machine without all guards and other safety protective devices in place and working on the machine.
- Keep children, bystanders, and pets out of the operating area. Never allow children to operate the machine.
- Always shut off the engine, remove the key (if equipped), wait for all moving parts to stop, and allow the machine to cool before adjusting, repairing, cleaning, or storing the machine.

Improperly using or maintaining this machine can result in injury. To reduce the potential for injury, comply with these safety instructions and always pay attention to the safety-alert symbol (Figure 2), which means Caution, Warning, or Danger—personal safety instruction. Failure to comply with these instructions may result in personal injury or death.

Safety and Instructional Decals



Safety decals and instructions are easily visible to the operator and are located near any area of potential danger. Replace any decal that is damaged or missing.



decal119-0217

119-0217

1. Warning—stop the engine; stay away from moving parts; keep all guards and shields in place.

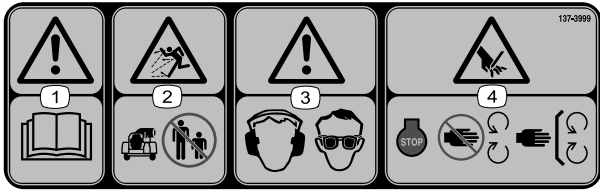

137-3999

decal137-3999

1. Warning—read the *Operator's Manual*.
2. Thrown object hazard—keep bystanders away from the machine.
3. Warning—wear hearing and eye protection.
4. Cutting/dismemberment hazard of hands—shut off the engine; keep hands away from moving parts; keep all guards and shields in place.

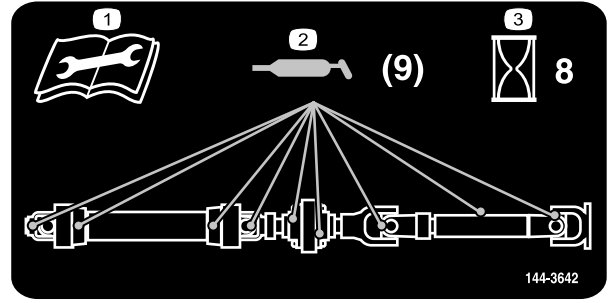

144-3642

decal144-3642

1. Read the *Operator's Manual* before performing maintenance.
2. Grease points
3. Service every 8 hours

WARNING: Cancer and Reproductive Harm - www.P65Warnings.ca.gov. For more information, please visit www.ttcoCAProp65.com

133-8061

decal133-8061

133-8061

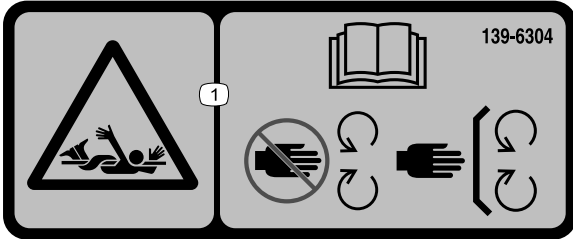

139-6304

decal139-6304

1. Entanglement hazard—read the *Operator's Manual*; stay away from moving parts; keep all guards and shields in place.

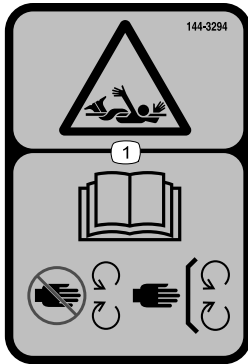

144-3294

decal144-3294

1. Entanglement hazard—read the *Operator's Manual*; stay away from moving parts; keep all guards and shields in place.

Setup

Loose Parts

Use the chart below to verify that all parts have been shipped.

Procedure	Description	Qty.	Use
1	Caster	2	Remove the blower from the crate.
	Bolt	4	
	Flange locknut	4	
2	Mounting plate assembly	1	Install the mounting plate to the debris blower frame.
	Bolt (1/2 x 1-1/4 inches)	4	
	Locknut (1/2 inch)	4	
3	No parts required	–	Prepare the traction unit for installation.
4	Debris blower assembly	1	Mount the blower to the traction unit.
	U-bolt	2	
	Locknut (3/8 inch)	4	
	Stop plate	2	
	Carriage bolt (5/16 x 3-1/4 inches)	4	
	Locknut (5/16 inch)	4	
5	No parts required	–	Install the jack stand to the storage tube.
6	Whip guide	2	Install the whip guides.
	Whip guide bracket	2	
	U-bolt	2	
	Hex-head bolt (5/16 x 1 inch)	4	
	Flange nut (3/8 inch)	4	
	Flange nut (5/16 inch)	4	
7	No parts required	–	Grease the machine.

Media and Additional Parts

Description	Qty.	Use
Operator's Manual	1	Read before operating the machine.

Note: Determine the left and right sides of the machine from the normal operating position.

Important: To install and operate the debris blower, the traction unit must be equipped with the Auxiliary Hydraulics Kit (Model 31966) and the Accessory Control Kit (Model 31994).

1

Removing the Blower from the Crate

Parts needed for this procedure:

2	Caster
4	Bolt
4	Flange locknut

Procedure

Important: Ensure that the jack stand is installed to stabilize the blower before you unbolt the blower frame from the shipping crate or remove the crate.

1. Remove the top of the crate (Figure 3).

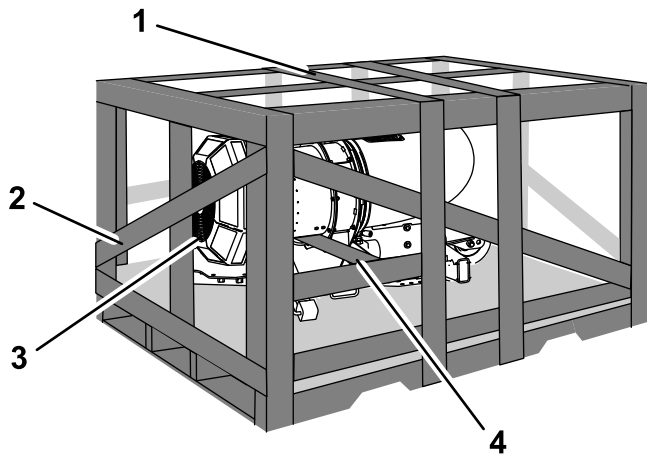

Figure 3

g362308

- | | |
|-----------------|-------------------------------|
| 1. Top of crate | 3. Top of machine |
| 2. End of crate | 4. Board under blower housing |

2. Remove the end of the crate which is toward the top of the machine (Figure 3).
3. Remove the board that is under the blower housing (Figure 3).
4. Remove the caster wheels from the crate.
5. Install the caster wheels to the machine with 4 bolts (1/2 x 3-1/2 inch) and 4 flange locknuts (1/2 inch); refer to Figure 4.

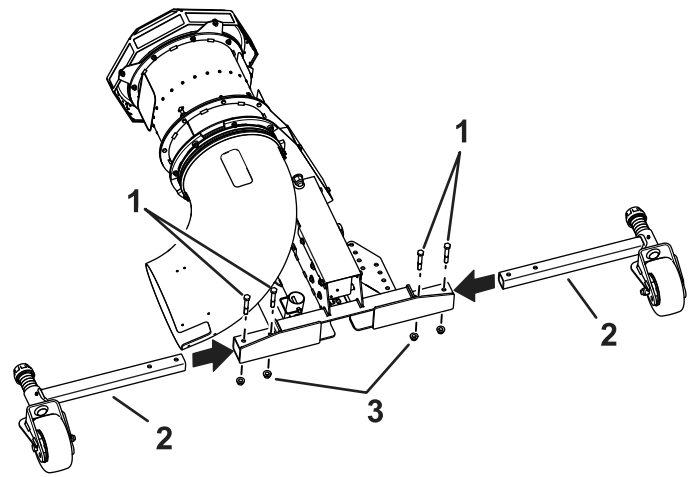

Figure 4

g362310

- | | |
|----------------------------|------------------------------|
| 1. Bolt (1/2 x 3-1/2 inch) | 3. Flange locknut (1/2 inch) |
| 2. Caster wheel | |

6. Secure a strap to the top end assembly and lift the pallet until the crate and blower is standing up vertically (Figure 5).

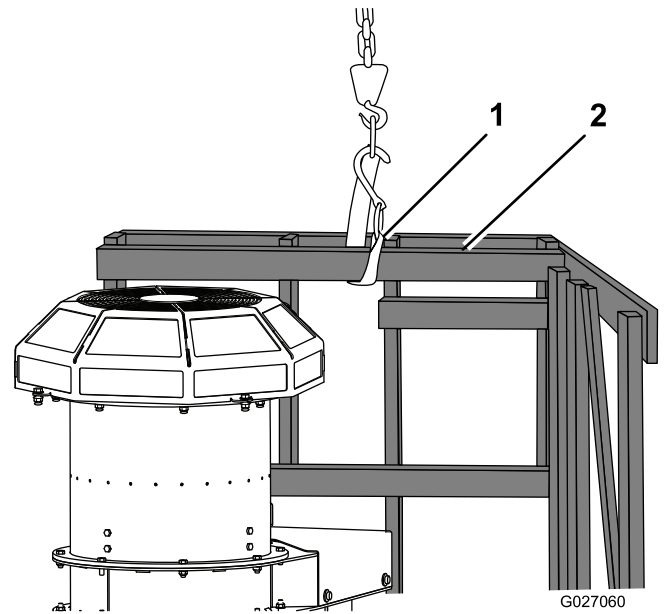

Figure 5

G027060

g027060

- | | |
|---------------|---------------------|
| 1. Lift strap | 2. Top end assembly |
|---------------|---------------------|

7. Remove the snapper pin securing the jack-stand tube to the storage tube (Figure 6). Remove the jack assembly from the storage position.

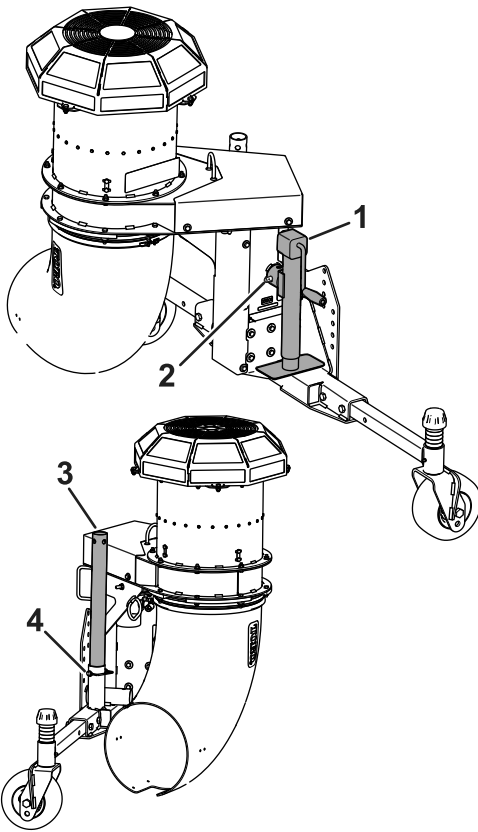

Figure 6

g363311

- | | |
|---------------|--------------------|
| 1. Jack stand | 3. Jack-stand tube |
| 2. Pin | 4. Snapper pin |

8. Remove the strap from the pallet and attach it to the lift loop on the blower (Figure 7).
9. Lift the blower until the strap is tight.

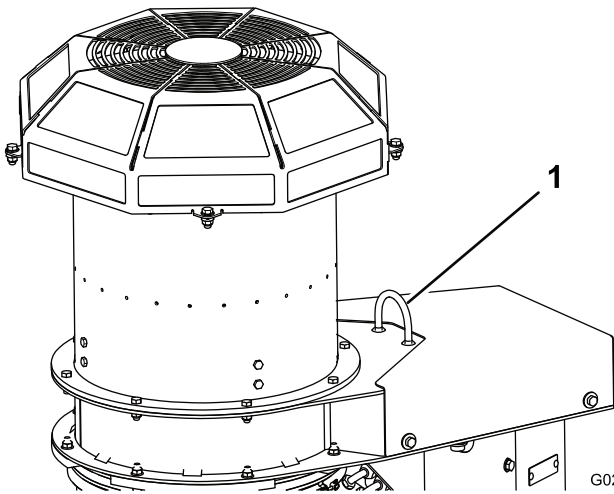

Figure 7

G021675
g021675

1. Lift loop

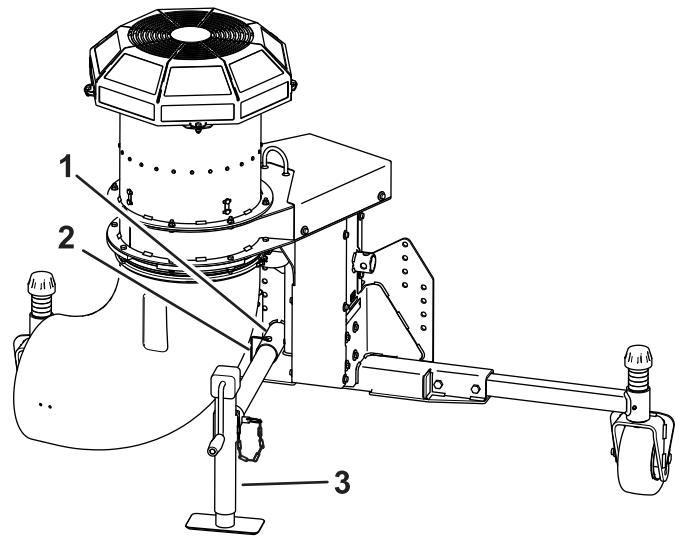

Figure 8

g362315

- | | |
|----------------|---------------|
| 1. Frame tube | 3. Jack stand |
| 2. Snapper pin | |

11. Remove the cable tie securing the crank handle to the jack crank.
12. Crank the jack stand down until the jack pad is level with the castor wheel tires.
13. Carefully remove the bolts holding the blower to the wood pallet.
14. Slide the crate away from the blower and lower the blower until the castor wheels and jack stand touch the floor keeping the strap tight (Figure 9).

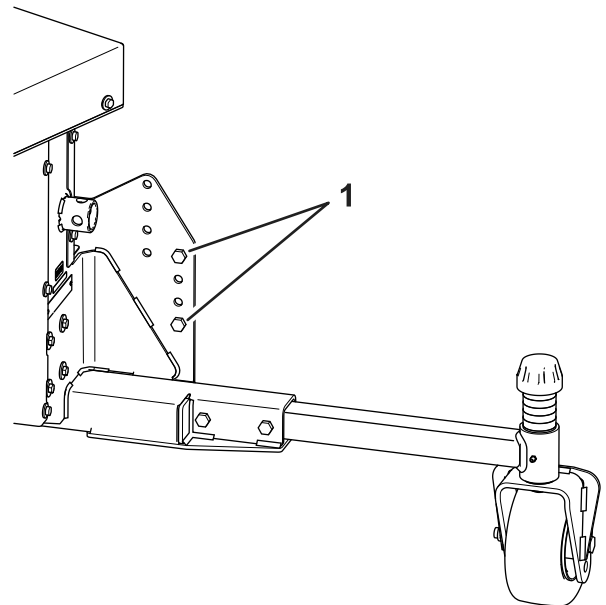

Figure 9

g362311

1. Bolts

10. Insert the jack-stand tube into the frame tube, align the holes, and secure it into position with the snapper pin (Figure 8).

15. Remove the strap from the blower lift loop.

2

Installing the Mounting Plate to the Debris Blower Frame

Parts needed for this procedure:

1	Mounting plate assembly
4	Bolt (1/2 x 1-1/4 inches)
4	Locknut (1/2 inch)

Procedure

1. Remove the bolts securing the mounting plate assembly to the crate (Figure 10).

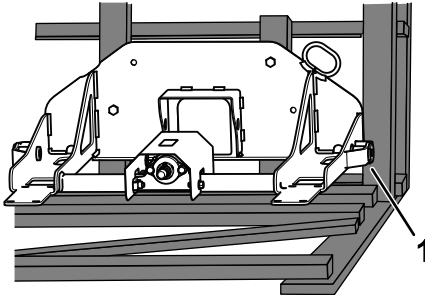

Figure 10

g350906

1. Mounting plate assembly

2. Install the mounting plate assembly to the debris blower frame with 4 bolts (1/2 x 1-1/4 inch) and 4 locknuts (1/2 inch) and connect the blower driveshaft to the splined shaft on the mounting plate assembly by sliding the quick coupler onto the shaft (Figure 11).

Note: Use the second lowest set of holes on each side of the mounting plate.

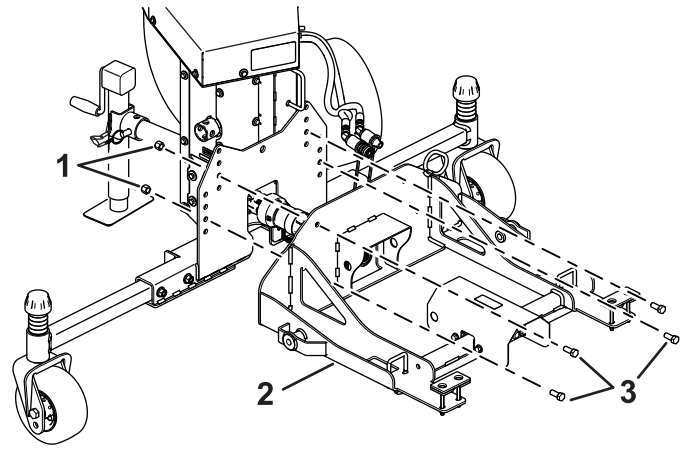

Figure 11

g362312

1. Locknuts
2. Mounting plate assembly
3. Bolts

3. Torque the bolts to 92 to 113 N-m (68 to 82 ft-lb).
4. Secure the safety chains to the mounting plate assembly.

3

Preparing the Traction Unit

No Parts Required

Procedure

Important: To install and operate the debris blower, the traction unit must be equipped with the Auxiliary Hydraulics Kit (Model 31966) and the Accessory Control Kit (Model 31994).

1. Park the traction unit on a level surface.
2. Disengage the power takeoff and lower the attachments.
3. Engage the parking brake, shut off the engine, remove the key, and wait for all movement to stop.
4. Remove the front attachment (if equipped) from the lift arms of the traction unit and disconnect the attachment PTO shaft; refer to the traction unit *Operator's Manual*.

Note: Retain the attachment mounting hardware for use in installation.

4

Mounting the Debris Blower to the Traction Unit

Parts needed for this procedure:

1	Debris blower assembly
2	U-bolt
4	Locknut (3/8 inch)
2	Stop plate
4	Carriage bolt (5/16 x 3-1/4 inches)
4	Locknut (5/16 inch)

Procedure

1. Move the traction unit into position behind the blower so the mounting plate assembly is in alignment with the lift arms of the traction unit.
2. Lower the lift arms into the mounting assembly as shown in [Figure 12](#), then engage the traction unit parking brake, shut off the engine, remove the key, and wait for all movement to stop.

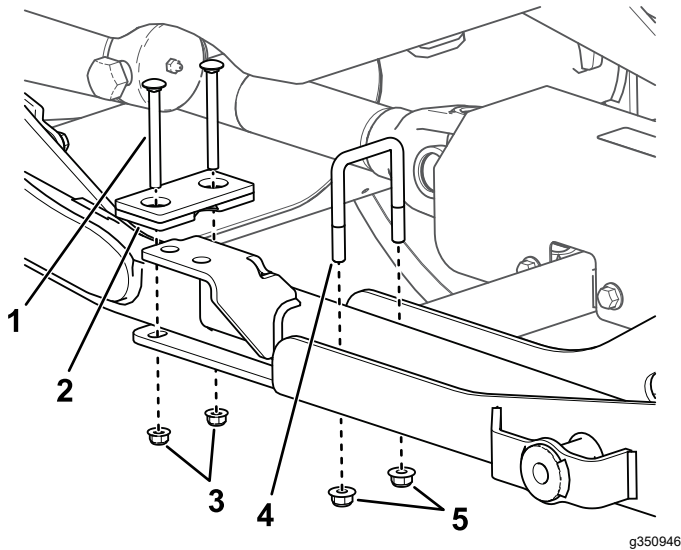

Figure 12
Right side shown

1. Carriage bolt (5/16 x 3-1/4 inches)
2. Stop plate
3. Locknut (5/16 inch)
4. U-bolt
5. Locknut (3/8 inch)

3. Secure the rear of the lift arms to mounting assembly using the provided U-bolts, stop plates, carriage bolts and locknuts ([Figure 12](#)).

4. Secure the front of the lift arms to the mounting assembly using the 2 hex-head bolts and 2 curved washers removed from the attachment in [3 Preparing the Traction Unit \(page 8\)](#) as shown in [Figure 13](#).

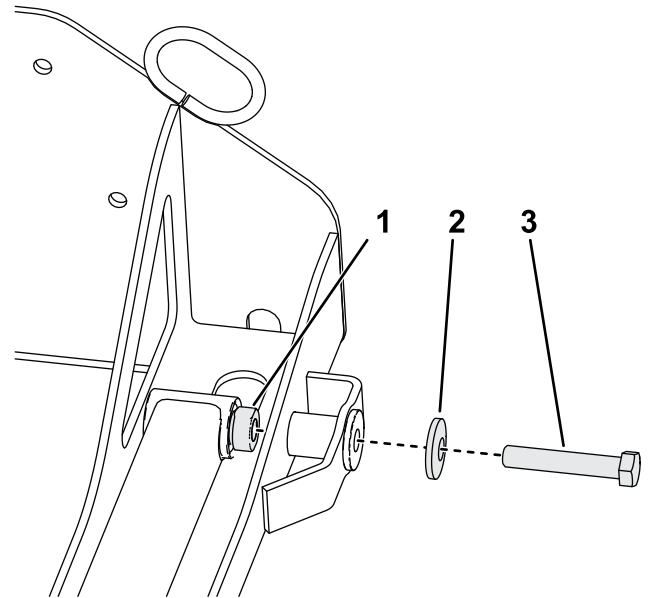

Figure 13
Right side shown

1. Shoulder bolt in the front of the lift arm
2. Curved washer
3. Hex-head bolt of the lift arm

If you have previously used the bolts to install the cutting unit: Apply thread-locking compound to the threads of the bolts.

5. Torque the bolts to the appropriate specification:
 - If you are using the bolts to install the attachment for the first time:
Torque the bolts to 256 to 313 N·m (189 to 231 ft-lb).
 - If you have previously used the bolts to install attachment:
Torque the bolts to 195 to 239 N·m (144 to 176 ft-lb).
6. Using the PTO connection hardware removed in [3 Preparing the Traction Unit \(page 8\)](#), secure the traction unit PTO shaft to the splined connecting shaft on the mounting plate assembly as shown in [Figure 14](#).

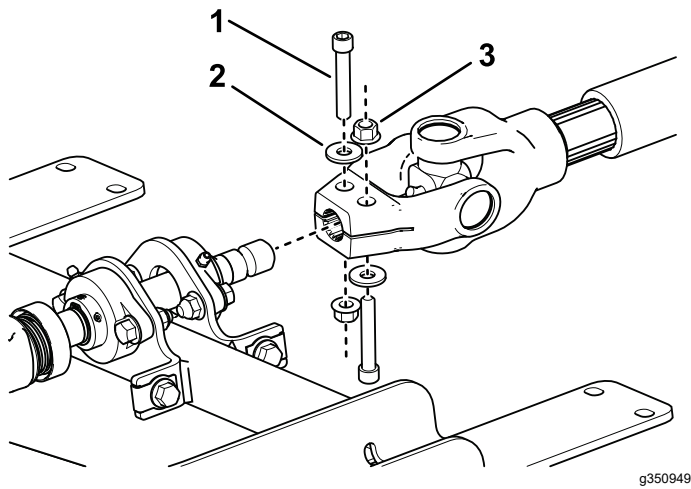

Figure 14

g350949

1. Capscrew
2. Washer
3. Locknut

7. Tighten the PTO connection hardware; refer to your machine's *Operator's Manual* for torque specifications.
8. Connect the driveshaft-cover chains to the areas shown in Figure 15.

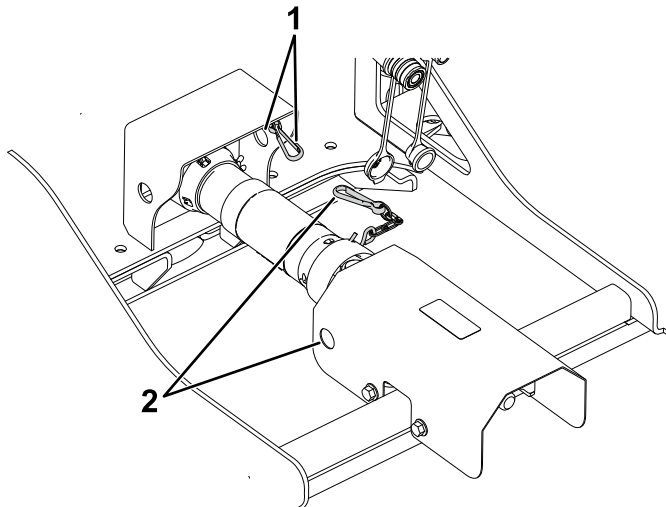

Figure 15

g367855

1. Inner-cover chain and connection point
2. Outer-cover chain and connection point

dust plugs are cleaned and then installed to prevent contamination from entering either hydraulic system.

5

Installing the Jack Stand to the Storage Tube

No Parts Required

Procedure

After you install the blower to the traction unit, remove the jack stand from the frame tube and use the snapper pin to install it to the storage tube (Figure 16). This allows you to oscillate the blower during operation.

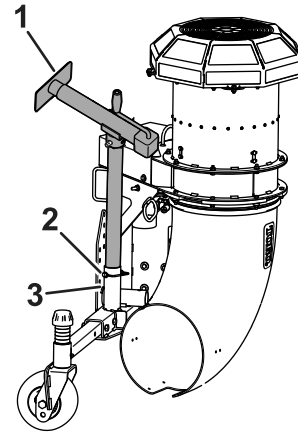

Figure 16

g367854

1. Jack stand
2. Snapper pin
3. Storage tube

9. Raise the blower jack stand higher than the castors.
10. Remove the dust plugs from the hydraulic couplers and ensure that the couplers are free of any dirt or debris.
11. Connect the attachment hydraulic hose couplers to the hydraulic couplers on the traction unit rear auxiliary hydraulic power kit.

Important: Whenever the hydraulic hose couplers are disconnected, make sure the

6

Installing the Whip Guides

Parts needed for this procedure:

2	Whip guide
2	Whip guide bracket
2	U-bolt
4	Hex-head bolt (5/16 x 1 inch)
4	Flange nut (3/8 inch)
4	Flange nut (5/16 inch)

Procedure

Use 4 bolts (5/16 x 1 inch), 4 flange nuts (5/16 inch), 2 U-bolts, 4 flange nuts (3/8 inch), and 2 whip guide brackets to install the whip guides to the caster arms (right side shown in [Figure 17](#) and [Figure 18](#)).

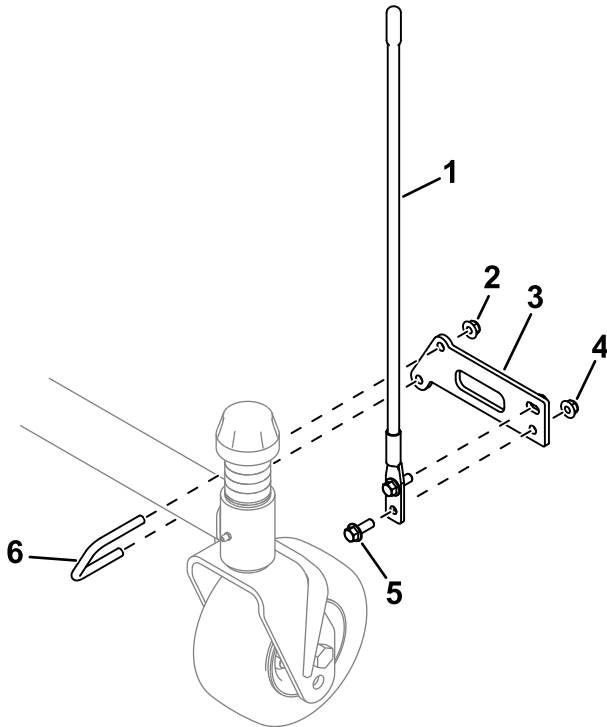

Figure 17

g367852

1. Whip guide
2. Flange nut (3/8 inch)
3. Whip guide bracket
4. Flange nut (5/16 inch)
5. Hex-head bolt (5/16 x 1 inch)
6. U-bolt

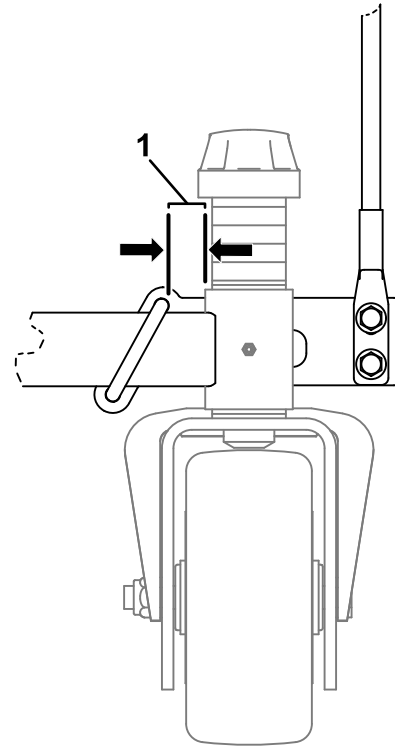

Figure 18

g367853

1. 2.5 cm (1 inch)

7

Greasing the Machine

No Parts Required

Procedure

To ensure proper lubricating characteristics, apply grease to the machine before operation; refer to [Lubricating the Blower \(page 15\)](#).

Important: Failure to properly grease the machine will result in premature failure of critical parts.

Operation

Note: Determine the left and right sides of the machine from the normal operating position.

Important: Only engage the PTO at low idle; engaging the PTO at high idle will reduce the life of the clutch.

Important: Do not operate the machine without the fan guard and gear-case guard in place (Figure 19).

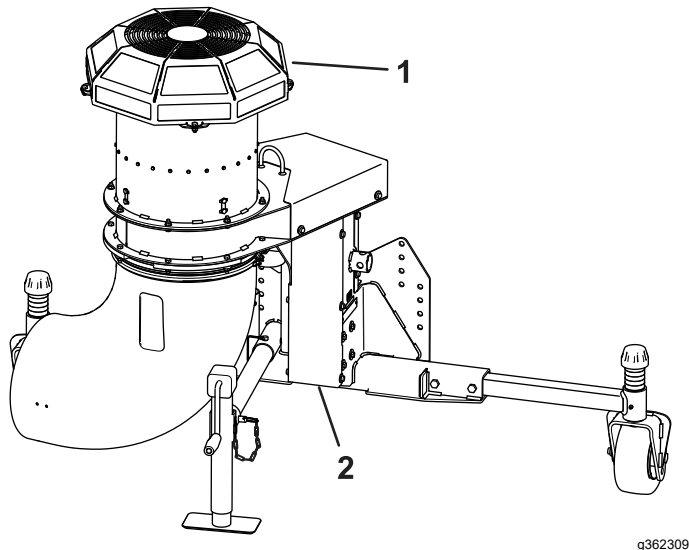

Figure 19

1. Fan guard 2. Gear case guard

Operation Safety

Before Operation Safety

- Never allow children or untrained people to operate or service the machine. Local regulations may restrict the age of the operator. The owner is responsible for training all operators and mechanics.
- Become familiar with the safe operation of the equipment, operator controls, and safety signs.
- Always wait for all moving parts to stop and allow the machine to cool before adjusting, repairing, cleaning, or storing the machine. Know how to stop the machine quickly.
- Keep all guards, safety devices, and decals in place. Repair or replace all safety devices and replace all illegible or missing decals. Do not operate the machine unless they are present and functioning properly.
- Do not modify this equipment in any manner.

During Operation Safety

- The owner/operator can prevent and is responsible for accidents that may cause personal injury or property damage.
- Wear appropriate clothing, including eye protection; long pants; substantial, slip-resistant footwear; and hearing protection. Tie back long hair and do not wear loose jewelry.
- Do not operate the machine while ill, tired, or under the influence of alcohol or drugs.
- Use your full attention while operating the machine. Do not engage in any activity that causes distractions; otherwise, injury or property damage may occur.
- Discharged air has considerable force and could cause injury or loss of footing. Stay away from the blower nozzle when the machine is operating.
- Keep all bystanders away; shut off the machine when bystanders enter the area, do not direct discharge toward them.
- Do not carry passengers on the machine and keep bystanders and pets away from the machine during operation.
- Operate the machine only in good visibility to avoid holes or hidden hazards.
- Look behind and down before backing up to be sure of a clear path.
- Use care when approaching blind corners, shrubs, trees, or other objects that may obscure your vision.
- Never leave a running machine unattended.
- If the machine ever vibrates abnormally, stop the machine immediately, shut off the engine, remove the key, wait for all moving parts to stop, and inspect for damage. Repair all damage to the machine before resuming operation.
- Reduce speed when operating on rough, uneven terrain, and near curbs, holes, and other sudden changes in terrain.

Slope Safety

- Slopes are a major factor related to loss of control and rollover accidents, which can result in severe injury or death. You are responsible for safe slope operation. Operating the machine on any slope requires extra caution.
- Review the traction unit specifications to ensure that you do not exceed its slope capabilities.
- Evaluate the site conditions to determine if the slope is safe for machine operation, including surveying the site. Always use common sense and good judgment when performing this survey.
- Review the slope instructions, listed below, for operating the machine on slopes. Before you

operate the machine, review the site conditions to determine whether you can operate the machine in the conditions on that day and at that site. Changes in the terrain can result in a change in slope operation for the machine.

- Avoid starting, stopping, or turning the machine on slopes. Avoid making sudden changes in speed or direction. Make turns slowly and gradually.
- Do not operate a machine under any conditions where traction, steering, or stability is in question.
- Remove or mark obstructions such as ditches, holes, ruts, bumps, rocks, or other hidden hazards. Tall grass can hide obstructions. Uneven terrain could overturn the machine.
- Be aware that operating the machine on wet grass, across slopes, or downhill may cause the machine to lose traction.
- Use extreme caution when operating the machine near drop-offs, ditches, embankments, water hazards, or other hazards. The machine could suddenly roll over if a wheel goes over the edge or the edge caves in. Establish a safety area between the machine and any hazard.

After Operation Safety

- Park the machine on a level surface; shut off the engine, remove the key, wait for all moving parts to stop, and allow the machine to cool before adjusting, repairing, cleaning, or storing the machine.
- Only disconnect the machine from the traction unit while on a level surface.
- Keep all parts of the machine in good working condition and all hardware tightened.
- Replace all worn, damaged, or missing decals.

Adjusting the Blower Nozzle Height

The blower nozzle can be operated at a height range from 114 to 216 mm (4.5 to 8.5 inches). To adjust the blower nozzle height, position the castor wheel axles in the upper or lower holes of the castor forks and add or remove an equal number of spacers from the castor forks.

1. Start the engine and raise the blower off the floor so that you can change the castor wheels.
2. Shut off the engine and remove the key.
3. Position the castor wheel axles in the same holes in both castor forks ([Figure 20](#)).

Note: Use the lower castor fork axle mounting holes to attain a higher blower nozzle height.

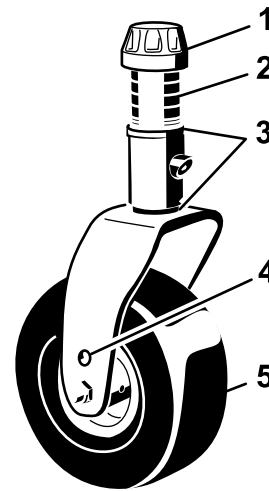

G008866

g008866

Figure 20

- | | |
|-------------------|------------------------|
| 1. Tensioning cap | 4. Axle mounting holes |
| 2. Spacers | 5. Castor wheel |
| 3. Shims | |

4. Remove the tensioning cap from the spindle shaft ([Figure 20](#)) and slide the spindle out of the castor arm.
5. Put the 2 shims (1/8 inch) onto the spindle shaft as they were originally installed.

Note: These shims are required to achieve a level across the entire width of the blower.

6. Slide the appropriate number of 1/2-inch spacers onto the spindle shaft to get the desired height; then slide the washer onto the shaft.
7. Push the castor spindle through the castor arm.
8. Install the shims (as they were originally installed) and the remaining spacers onto the spindle shaft.
9. Install the tensioning cap to secure the assembly.

Operating Tips

⚠ WARNING

Discharged air has considerable force and could cause injury or loss of footing.

- **Stay away from the nozzle opening while the machine is operating.**
- **Keep bystanders away from the nozzle opening while the machine is running.**
- Practice operating the blower. Blow the same direction that the wind is blowing to prevent material from blowing back into the cleared area.
- Be alert, slow down, and use caution when making turns. Look behind and to the side before changing directions.
- Be aware of the blower nozzle direction and do not point it at anyone.
- Use care when approaching blind corners, shrubs, trees, or other objects that may obscure vision.
- Check carefully for overhead clearances (i.e., branches, doorways, electrical wires) before driving under any objects and do not allow them to contact the blower screen.
- Reduce your speed when making sharp turns or turning on hillsides.
- Before backing up, look to the rear and ensure that no one is behind the machine.
- Use caution when blowing around newly planted sod as the force of the air could disrupt the grass.
- Stay away from the nozzle opening when the machine is operating. Keep all bystanders away from the nozzle opening and do not direct the discharge toward bystanders.
- **Do not take an injury risk.** When a person or pet appears unexpectedly in or near the operating area, **stop the machine and shut off the engine.** Careless operation, combined with terrain angles, ricochets, or improperly positioned guards can lead to thrown object injuries. Do not resume operation until the area is cleared.

***Important:* Raise the blower before transporting. If the nozzle is left in the down position during transport, the nozzle may contact the ground, which may damage the nozzle.**

Maintenance

Maintenance Safety

- Before cleaning, servicing, or adjusting the machine, do the following:
 - Park the machine on a level surface.
 - Wait for all moving parts to stop.
 - Remove the machine from the traction unit.
 - Lower the jack stand.
 - Allow machine components to cool before performing maintenance.
- Perform only those maintenance instructions described in this manual. If major repairs are ever needed or you need assistance, contact an authorized Toro distributor.
- Support the machine with blocks or jack stands when working beneath it.
- Ensure that all guards are installed securely after maintaining or adjusting the machine.
- Do not allow untrained personnel to service the machine.
- Keep all parts in good working condition and all fasteners tightened. Replace all damaged or missing decals.
- Do not interfere with the intended function of a safety device or reduce the protection provided by a safety device. Check their proper operation regularly.
- If major repairs are ever necessary or assistance is required, contact an authorized Toro distributor.
- Altering this machine in any manner may affect the operation of the machine, performance, durability, or its use may result in injury or death. Such use could void the product warranty of The Toro® Company.

Lubricating the Blower

Service Interval: Every 50 hours

The debris blower has bearings and bushings that must be lubricated regularly. If the machine is operated under normal conditions, lubricate bearings with No. 2 lithium grease. Lubricate fittings immediately after every washing, regardless of the interval listed.

The lubrication points are as follows:

Drive pulley (Figure 21)

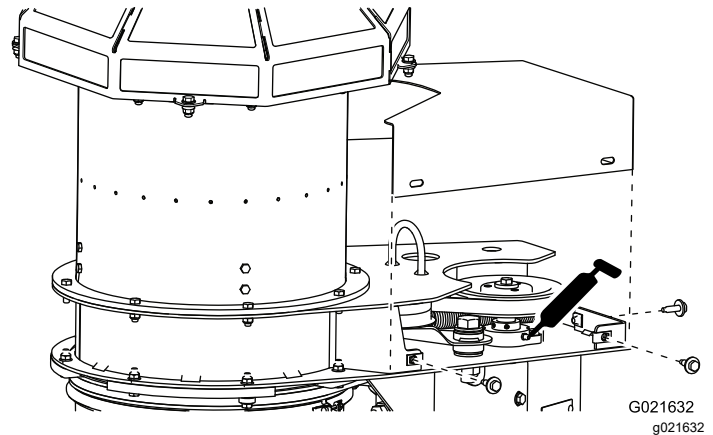

Figure 21

Shown with cover removed

Castor wheel shaft (2) (Figure 22)

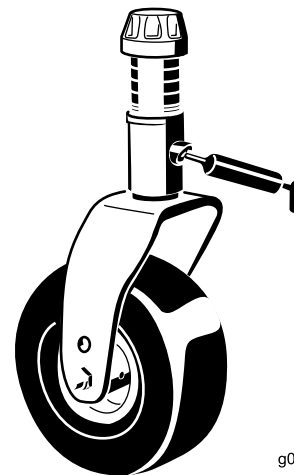

Figure 22

Lubricating the Driveshaft

Service Interval: Before each use or daily

The mounting kit drive shaft has bearings and bushings that you must lubricate regularly. If you are operating the machine under normal conditions, lubricate bearings with No. 2 lithium grease. Lubricate fittings immediately after every washing, regardless of the interval listed.

1. Position the machine and blower on a level surface and lower the blower.
2. There are 9 grease points; refer to the mount kit service decal or [Figure 23](#).

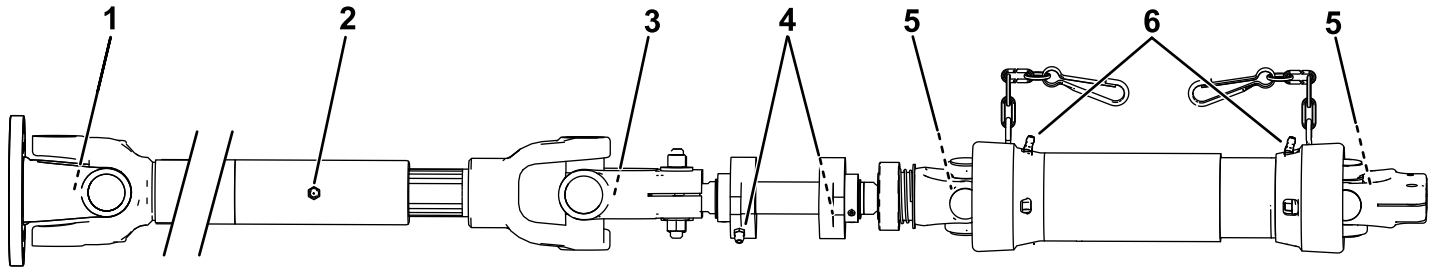

Figure 23

g368041

1. Grease the cross bearing on the machine-side driveshaft section that connects to the drive.
 2. Grease the outer shaft of the machine-side driveshaft section.
 3. Grease the cross bearing on the machine-side driveshaft section that connects flange bearing shaft.
 4. Grease each flange bearing between the 2 main shaft sections.
 5. Grease the cross bearings on the blower driveshaft.
 6. Grease each guard bushing at either end of the blower driveshaft guards.
-

Checking the Gearbox Lubrication

Service Interval: After the first 50 hours
Every 150 hours

Gearbox capacity: 177 ml (6 fl oz).

1. Position the machine and blower on a level surface and lower the blower.
2. Remove the 5 bolts and washers securing the gear case cover to the blower (Figure 24).

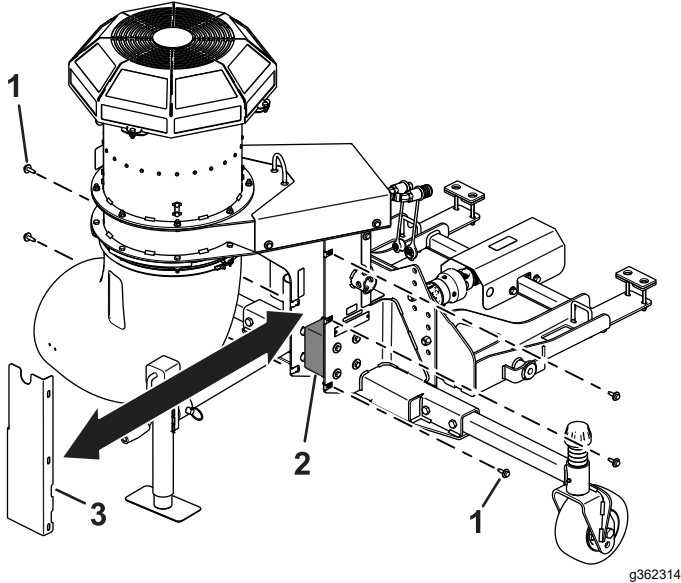

Figure 24

1. Screw
2. Gearbox
3. Cover

3. Remove the cover to expose the blower gear case (Figure 24).
4. Remove the check/fill plug from the side of the gearbox (Figure 25).

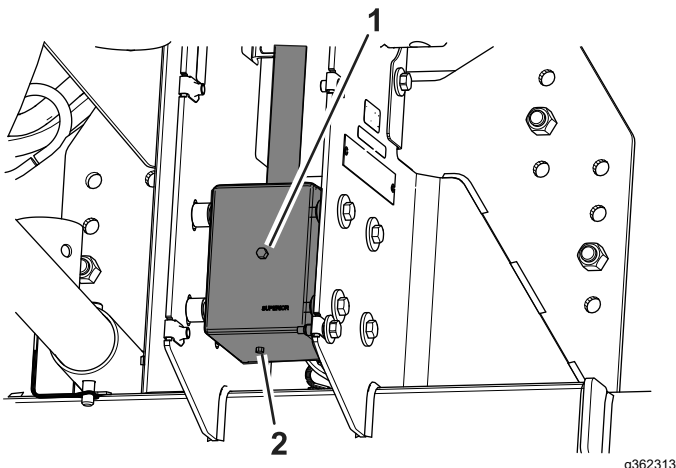

Figure 25

1. Check/fill plug
2. Drain plug

5. Check the oil level to make sure it is up to the plug hole in the gearbox. If the lubricant level is low, add enough SAE 80-90 weight gear lube to raise the level up to the hole.
6. Install the check/fill plug to the gearbox.
7. Install the cover.

Checking the Nozzle

Service Interval: Before each use or daily

Checking the Nozzle Clamp and Adjusting Position

⚠ WARNING

Discharged air has considerable force and could cause injury or loss of footing.

Park the traction unit on a level surface, disengage the PTO, remove the key, and wait for all moving parts to stop before adjusting the position of the blower nozzle.

1. Check the nozzle clamp (Figure 26) daily to ensure that is tight.

Note: The nozzle can loosen if it is dragged over obstacles or through low areas in the terrain.

2. Tighten the clamp fasteners to maintain a gap of 1.3 cm (0.50 inch).

The nozzle should rotate freely when you move it by hand.

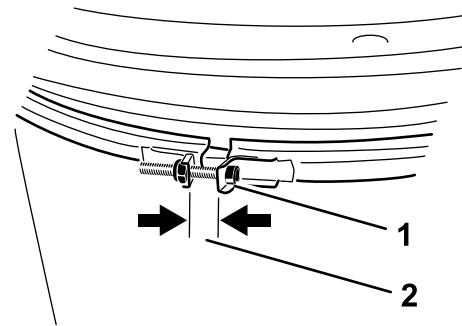

Figure 26

1. Nozzle clamp
2. 1.3 cm (0.5 inch) gap

Cleaning the Nozzle Guides

Check and remove any grass, dirt or debris buildup around and in between the nozzle guides (Figure 27).

Keep the nozzle free of debris to prevent the motor from stalling.

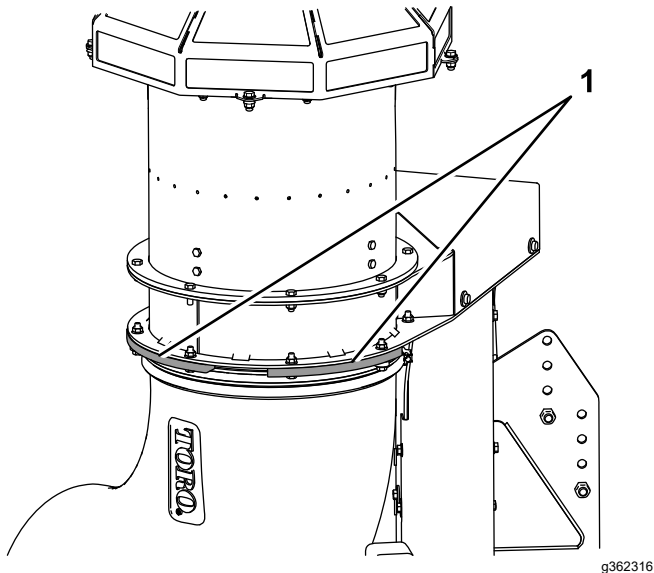

Figure 27

1. Nozzle guides

Adjusting the Nozzle Belt

Service Interval: After the first 8 hours

Every 50 hours

Adjust the belt if the belt slips when changing direction of the nozzle.

1. Press the belt, at the center of the longest span, with 30 N·m (22 lb) of force (Figure 28).

Note: The belt should deflect 4.8 mm (0.19 inch).

2. If the deflection is incorrect, proceed to the next step. If it is correct, continue operation.

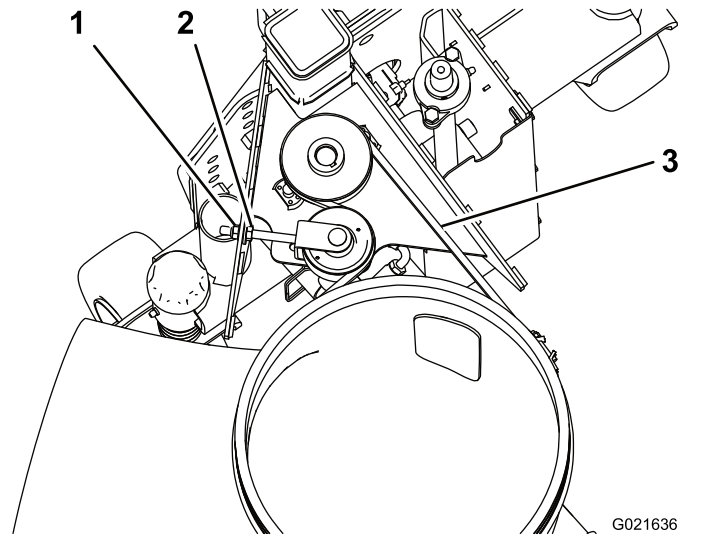

Figure 28

1. Flange nut
2. Hex nut
3. Depress belt here

3. Loosen the hex nut and tighten the flange nut to increase the belt tension (Figure 28).

Note: Do not over tighten.

4. Tighten the hex nut to lock the adjustment.

Storage

1. Remove grass clippings, dirt, and grime from the external parts of the entire blower.

Important: You can wash the machine with mild detergent and water. Do not pressure wash the machine. Avoid excessive use of water.

2. Check and tighten all bolts and nuts. Replace any worn parts.
3. Paint all scratched or bare metal surfaces. Paint is available from your Authorized Service Dealer.
4. Store the machine in a clean, dry garage, or storage area. Use the jack stand to store the blower in the upright position. Do not lay the blower down on the ground.

Notes:

Declaration of Incorporation

The Toro Company, 8111 Lyndale Ave. South, Bloomington, MN, USA declares that the following unit(s) conform(s) to the directives listed, when installed in accordance with the accompanying instructions onto certain Toro models as indicated on the relevant Declarations of Conformity.

Model No.	Serial No.	Product Description	Invoice Description	General Description	Directive
31916	410200000 and Up	Pro Force Debris Blower	PROFORCE BLOWER (GM3200/GM3300)	Debris Blower	2000/14/EC and 2005/88/EC 2014/30/EU

Relevant technical documentation has been compiled as required per Part B of Annex VII of 2006/42/EC.

We will undertake to transmit, in response to requests by national authorities, relevant information on this partly completed machinery. The method of transmission shall be electronic transmittal.

This machinery shall not be put into service until incorporated into approved Toro models as indicated on the associated Declaration of Conformity and in accordance with all instructions, whereby it can be declared in conformity with all relevant Directives.

Certified:



Tom Langworthy
Engineering Director
8111 Lyndale Ave. South
Bloomington, MN 55420, USA
November 1, 2022

Authorized Representative:

Marcel Dutrieux
Manager European Product Integrity
Toro Europe NV
Nijverheidsstraat 5
2260 Oevel
Belgium

UK Declaration of Incorporation

The Toro Company, 8111 Lyndale Ave. South, Bloomington, MN, USA declares that the following unit(s) conform(s) to the regulations listed, when installed in accordance with the accompanying instructions onto certain Toro models as indicated on the relevant Declarations of Conformity.

Model No.	Serial No.	Product Description	Invoice Description	General Description	Regulation
31916	410200000 and Up	Pro Force Debris Blower	PROFORCE BLOWER (GM3200/GM3300)	Debris Blower	S.I. 2001 No. 1701 S.I. 2016 No. 1091

Relevant technical documentation has been compiled as required per Schedule 10 of S.I. 2008 No. 1597.

We will undertake to transmit, in response to requests by national authorities, relevant information on this partly completed machinery. The method of transmission shall be electronic transmittal.

This machinery shall not be put into service until incorporated into approved Toro models as indicated on the associated Declaration of Conformity and in accordance with all instructions, whereby it can be declared in conformity with all relevant Regulations.

This declaration has been issued under the sole responsibility of the manufacturer.

The object of the declaration is in conformity with relevant UK legislation.



Tom Langworthy
Engineering Director
8111 Lyndale Ave. South
Bloomington, MN 55420, USA
November 1, 2022

Authorized Representative:

Marcel Dutrieux
Manager European Product Integrity
Toro U.K. Limited
Spellbrook Lane West
Bishop's Stortford
CM23 4BU
United Kingdom

California Proposition 65 Warning Information

What is this warning?

You may see a product for sale that has a warning label like the following:



WARNING: Cancer and Reproductive Harm—www.p65Warnings.ca.gov.

What is Prop 65?

Prop 65 applies to any company operating in California, selling products in California, or manufacturing products that may be sold in or brought into California. It mandates that the Governor of California maintain and publish a list of chemicals known to cause cancer, birth defects, and/or other reproductive harm. The list, which is updated annually, includes hundreds of chemicals found in many everyday items. The purpose of Prop 65 is to inform the public about exposure to these chemicals.

Prop 65 does not ban the sale of products containing these chemicals but instead requires warnings on any product, product packaging, or literature with the product. Moreover, a Prop 65 warning does not mean that a product is in violation of any product safety standards or requirements. In fact, the California government has clarified that a Prop 65 warning "is not the same as a regulatory decision that a product is 'safe' or 'unsafe.'" Many of these chemicals have been used in everyday products for years without documented harm. For more information, go to <https://oag.ca.gov/prop65/faqs-view-all>.

A Prop 65 warning means that a company has either (1) evaluated the exposure and has concluded that it exceeds the "no significant risk level"; or (2) has chosen to provide a warning based on its understanding about the presence of a listed chemical without attempting to evaluate the exposure.

Does this law apply everywhere?

Prop 65 warnings are required under California law only. These warnings are seen throughout California in a wide range of settings, including but not limited to restaurants, grocery stores, hotels, schools, and hospitals, and on a wide variety of products. Additionally, some online and mail order retailers provide Prop 65 warnings on their websites or in catalogs.

How do the California warnings compare to federal limits?

Prop 65 standards are often more stringent than federal and international standards. There are various substances that require a Prop 65 warning at levels that are far lower than federal action limits. For example, the Prop 65 standard for warnings for lead is 0.5 µg/day, which is well below the federal and international standards.

Why don't all similar products carry the warning?

- Products sold in California require Prop 65 labelling while similar products sold elsewhere do not.
- A company involved in a Prop 65 lawsuit reaching a settlement may be required to use Prop 65 warnings for its products, but other companies making similar products may have no such requirement.
- The enforcement of Prop 65 is inconsistent.
- Companies may elect not to provide warnings because they conclude that they are not required to do so under Prop 65; a lack of warnings for a product does not mean that the product is free of listed chemicals at similar levels.

Why does Toro include this warning?

Toro has chosen to provide consumers with as much information as possible so that they can make informed decisions about the products they buy and use. Toro provides warnings in certain cases based on its knowledge of the presence of one or more listed chemicals without evaluating the level of exposure, as not all the listed chemicals provide exposure limit requirements. While the exposure from Toro products may be negligible or well within the "no significant risk" range, out of an abundance of caution, Toro has elected to provide the Prop 65 warnings. Moreover, if Toro does not provide these warnings, it could be sued by the State of California or by private parties seeking to enforce Prop 65 and subject to substantial penalties.



The Toro Warranty

Two-Year or 1,500 Hours Limited Warranty

Conditions and Products Covered

The Toro Company warrants your Toro Commercial product ("Product") to be free from defects in materials or workmanship for 2 years or 1,500 operational hours*, whichever occurs first. This warranty is applicable to all products with the exception of Aerators (refer to separate warranty statements for these products). Where a warrantable condition exists, we will repair the Product at no cost to you including diagnostics, labor, parts, and transportation. This warranty begins on the date the Product is delivered to the original retail purchaser.

* Product equipped with an hour meter.

Instructions for Obtaining Warranty Service

You are responsible for notifying the Commercial Products Distributor or Authorized Commercial Products Dealer from whom you purchased the Product as soon as you believe a warrantable condition exists. If you need help locating a Commercial Products Distributor or Authorized Dealer, or if you have questions regarding your warranty rights or responsibilities, you may contact us at:

Toro Commercial Products Service Department
8111 Lyndale Avenue South
Bloomington, MN 55420-1196

952-888-8801 or 800-952-2740
E-mail: commercial.warranty@toro.com

Owner Responsibilities

As the product owner, you are responsible for required maintenance and adjustments stated in your *Operator's Manual*. Repairs for product issues caused by failure to perform required maintenance and adjustments are not covered under this warranty.

Items and Conditions Not Covered

Not all product failures or malfunctions that occur during the warranty period are defects in materials or workmanship. This warranty does not cover the following:

- Product failures which result from the use of non-Toro replacement parts, or from installation and use of add-on, or modified non-Toro branded accessories and products.
- Product failures which result from failure to perform recommended maintenance and/or adjustments.
- Product failures which result from operating the Product in an abusive, negligent, or reckless manner.
- Parts consumed through use that are not defective. Examples of parts which are consumed, or used up, during normal Product operation include, but are not limited to, brake pads and linings, clutch linings, blades, reels, rollers and bearings (sealed or greasable), bed knives, spark plugs, castor wheels and bearings, tires, filters, belts, and certain sprayer components such as diaphragms, nozzles, flow meters, and check valves.
- Failures caused by outside influence, including, but not limited to, weather, storage practices, contamination, use of unapproved fuels, coolants, lubricants, additives, fertilizers, water, or chemicals.
- Failure or performance issues due to the use of fuels (e.g. gasoline, diesel, or biodiesel) that do not conform to their respective industry standards.
- Normal noise, vibration, wear and tear, and deterioration. Normal "wear and tear" includes, but is not limited to, damage to seats due to wear or abrasion, worn painted surfaces, scratched decals or windows.

Countries Other than the United States or Canada

Customers who have purchased Toro products exported from the United States or Canada should contact their Toro Distributor (Dealer) to obtain guarantee policies for your country, province, or state. If for any reason you are dissatisfied with your Distributor's service or have difficulty obtaining guarantee information, contact your Authorized Toro Service Center.

Parts

Parts scheduled for replacement as required maintenance are warranted for the period of time up to the scheduled replacement time for that part. Parts replaced under this warranty are covered for the duration of the original product warranty and become the property of Toro. Toro will make the final decision whether to repair any existing part or assembly or replace it. Toro may use remanufactured parts for warranty repairs.

Deep Cycle and Lithium-Ion Battery Warranty

Deep cycle and Lithium-Ion batteries have a specified total number of kilowatt-hours they can deliver during their lifetime. Operating, recharging, and maintenance techniques can extend or reduce total battery life. As the batteries in this product are consumed, the amount of useful work between charging intervals will slowly decrease until the battery is completely worn out. Replacement of worn out batteries, due to normal consumption, is the responsibility of the product owner. Note: (Lithium-Ion battery only): Refer to the battery warranty for additional information.

Lifetime Crankshaft Warranty (ProStripe 02657 Model Only)

The ProStripe which is fitted with a genuine Toro Friction Disc and Crank-Safe Blade Brake Clutch (integrated Blade Brake Clutch (BBC) + Friction Disc assembly) as original equipment and used by the original purchaser in accordance with recommended operating and maintenance procedures, are covered by a Lifetime Warranty against engine crankshaft bending. Machines fitted with friction washers, Blade Brake Clutch (BBC) units and other such devices are not covered by the Lifetime Crankshaft Warranty.

Maintenance is at Owner's Expense

Engine tune-up, lubrication, cleaning and polishing, replacement of filters, coolant, and completing recommended maintenance are some of the normal services Toro products require that are at the owner's expense.

General Conditions

Repair by an Authorized Toro Distributor or Dealer is your sole remedy under this warranty.

The Toro Company is not liable for indirect, incidental or consequential damages in connection with the use of the Toro Products covered by this warranty, including any cost or expense of providing substitute equipment or service during reasonable periods of malfunction or non-use pending completion of repairs under this warranty. Except for the Emissions warranty referenced below, if applicable, there is no other express warranty. All implied warranties of merchantability and fitness for use are limited to the duration of this express warranty.

Some states do not allow exclusions of incidental or consequential damages, or limitations on how long an implied warranty lasts, so the above exclusions and limitations may not apply to you. This warranty gives you specific legal rights, and you may also have other rights which vary from state to state.

Note Regarding Emissions Warranty

The Emissions Control System on your Product may be covered by a separate warranty meeting requirements established by the U.S. Environmental Protection Agency (EPA) and/or the California Air Resources Board (CARB). The hour limitations set forth above do not apply to the Emissions Control System Warranty. Refer to the Engine Emission Control Warranty Statement supplied with your product or contained in the engine manufacturer's documentation.