



Multi-Pro[®] 5600 Turf Sprayer

Model No. 41568—Serial No. 230000001 and Up

Operator's Manual



Warning



CALIFORNIA

Proposition 65 Warning

The engine exhaust from this product contains chemicals known to the State of California to cause cancer, birth defects, or other reproductive harm.

Important The engine in this product is not equipped with a spark arrester muffler. It is a violation of California Public Resource Code Section 4442 to use or operate this engine on any forest-covered, brush-covered, or grass-covered land as defined in CPRC 4126. Other states or federal areas may have similar laws.

This spark ignition system complies with Canadian ICES-002.

Ce système d'allumage par étincelle de véhicule est conforme à la norme NMB-002 du Canada.

Contents

	Page
Introduction	3
Safety	3
Safe Operating Practices	3
Chemical Safety	4
Before Operating	4
While Operating	5
Maintenance	6
Safety and Instruction Decals	7
Specifications	10
Optional Equipment	10
Setup	11
Loose Parts	11
Installing the Anti-siphon Fill Receptacle	12
Before Operating	12
Checking the Engine Oil	12
Checking the Tire Pressure	13
Adding Fuel	13
Checking the Coolant Level	13
Checking the Hydraulic Fluid	14
Checking the Brakes	14
Filling the Fresh Water Tank	14
Operation	15
Think Safety First	15
Vehicle Controls	15
Pre-Starting Checks	17
Starting the Engine	17
Driving the Sprayer	17

	Page
Introduction	3
Safety	3
Safe Operating Practices	3
Chemical Safety	4
Before Operating	4
While Operating	5
Maintenance	6
Safety and Instruction Decals	7
Specifications	10
Optional Equipment	10
Setup	11
Loose Parts	11
Installing the Anti-siphon Fill Receptacle	12
Before Operating	12
Checking the Engine Oil	12
Checking the Tire Pressure	13
Adding Fuel	13
Checking the Coolant Level	13
Checking the Hydraulic Fluid	14
Checking the Brakes	14
Filling the Fresh Water Tank	14
Operation	15
Think Safety First	15
Vehicle Controls	15
Pre-Starting Checks	17
Starting the Engine	17
Driving the Sprayer	17

Introduction

Read this manual carefully to learn how to operate and maintain your product properly. The information in this manual can help you and others avoid injury and product damage. Although Toro designs and produces safe products, you are responsible for operating the product properly and safely.

You may contact Toro directly on the internet at www.Toro.com for product and accessory information, help finding a dealer, or to register your product.

Whenever you need service, genuine Toro parts, or additional information, contact an Authorized Service Dealer or Toro Customer Service and have the model and serial numbers of your product ready. Figure 1 illustrates the location of the model and serial numbers on the product.

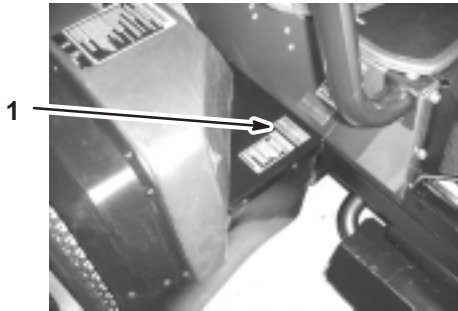

Figure 1

1. Location of the model and serial numbers

Write the product model and serial numbers in the space below:

Model No. _____
Serial No. _____

This manual identifies potential hazards and has special safety messages that help you and others avoid personal injury and even death. **Danger**, **Warning**, and **Caution** are signal words used to identify the level of hazard. However, regardless of the hazard, be extremely careful.

Danger signals an extreme hazard that *will* cause serious injury or death if you do not follow the recommended precautions.

Warning signals a hazard that *may* cause serious injury or death if you do not follow the recommended precautions.

Caution signals a hazard that may cause minor or moderate injury if you do not follow the recommended precautions.

This manual uses two other words to highlight information.

Important calls attention to special mechanical information and **Note**: emphasizes general information worthy of special attention.



Safety

Improper use or maintenance by the operator or owner can result in injury. To reduce the potential for injury, comply with these safety instructions and always pay attention to the safety alert ⚠ symbol, which means CAUTION, WARNING, or DANGER—“personal safety instruction.” Failure to comply with the instruction may result in personal injury or death.

Supervisors, operators, and service persons should be familiar with the following standards and publications: (The material may be obtained from the addresses shown).

- Flammable and Combustible Liquids Code:
ANSI/NFPA 30
- National Fire Protection Association:
ANSI/NFPA #505; Powered Industrial Trucks
National Fire Prevention Association
Barrymarch Park
Quincy, Massachusetts 02269 U.S.A.
- ANSI/ASME B56.8 Personal Burden Carriers
American National Standards Institute, Inc.
1430 Broadway
New York, New York 10018 U.S.A.
- ANSI/UL 558; Internal Combustion Engine Powered Industrial Trucks
American National Standards Institute, Inc.
1430 Broadway
New York, New York 10018 U.S.A.
or
Underwriters Laboratories
333 Pfingsten Road
Northbrook, Illinois 60062 U.S.A.



Safe Operating Practices

	Warning	
The sprayer is an off-highway vehicle only and is not designed, equipped, or manufactured for use on public streets, roads, or highways.		

Supervisor's Responsibilities

- Make sure that operators are thoroughly trained and familiar with the *Operator's Manual*, Engine Manual, and all labels on the sprayer.
- Establish your own special procedures and work rules for unusual operating conditions (e.g. slopes too steep for sprayer operation).

Chemical Safety

 **Warning** 

Chemicals are hazardous and can injure you, bystanders, animals, plants, soils, or other property.

- **Carefully read and follow the chemical manufacturer's instructions for the safe preparation, use, and disposal of the chemical.**
- **Keep chemicals off of your or bystander's skin. If contact should occur, wash it off immediately with clean water and detergent.**
- **Wear goggles and other protective equipment as instructed by the chemical manufacturer.**

- Obtain proper training before using or handling chemicals.
- Use the correct chemical for the job.
- Follow the chemical manufacturer's instructions for the safe application of the chemical.
- Handle chemicals in a well ventilated area.
- Wear goggles and other protective equipment as instructed by the chemical manufacturer. Ensure that as little skin as possible is exposed while using chemicals.
- Have clean water available especially when filling the spray tank.
- Do not eat, drink, or smoke while working with chemicals.
- Always wash your hands and other exposed areas as soon as possible after finishing the work.
- Properly dispose of unused chemicals and chemical containers as instructed by the chemical manufacturer and your local codes.
- Chemicals and fumes in the tanks are dangerous; never enter the tank or place your head over or in the opening.



Before Operating

- Operate the machine only after reading and understanding the contents of this manual.

- **Never** allow children to operate the sprayer. Anyone who operates the sprayer should have a motor vehicle license.
- **Never** allow other adults to operate the sprayer without first reading and understanding the Operator's Manual. Only trained and authorized persons should operate this sprayer. Make sure that all operators are physically and mentally capable of operating the sprayer.
- This sprayer is designed to carry **only you**, the operator, and **one passenger** in the seat provided by the manufacturer. **Never** carry any other passengers on the sprayer.
- **Never** operate the sprayer when under the influence of drugs or alcohol. Even prescription drugs and cold medicines can cause drowsiness.
- Do not drive the sprayer when you are tired. Be sure to take occasional breaks. It is very important that you stay alert at all times.
- Become familiar with the controls and know how to stop the engine quickly.
- Keep all shields, safety devices, and decals in place. If a shield, safety device, or decal is malfunctioning, illegible, or damaged, repair or replace it before operating the machine.
- Always wear substantial shoes. Do not operate the machine while wearing sandals, tennis shoes, or sneakers. Do not wear loose fitting clothing or jewelry which could get caught in moving parts and cause personal injury.
- Wearing safety glasses, safety shoes, long pants, and a helmet is advisable and required by some local safety and insurance regulations.
- Avoid driving when it is dark, especially in unfamiliar areas. If you must drive when it is dark, be sure to drive cautiously, use the headlights, and even consider adding additional lights.
- Be extremely careful when operating around people. Always be aware of where bystanders might be.
- Before operating the sprayer, always check the designated areas of the sprayer that are stated in the Pre-Starting section of this manual, page 17. If something is wrong, do **not** use the sprayer. Make sure that the problem is corrected before the sprayer or attachment is operated.
- Ensure that all fluid line connectors are tight and all hoses are in good condition before applying pressure to the system.
- Since gasoline is highly flammable, handle it carefully.
 - Use an approved gasoline container.
 - Do not remove the cap from the fuel tank when the engine is hot or running.

- Do not smoke while handling gasoline.
- Fill the fuel tank outdoors, and fill it to about 1 inch (25 mm) below the top of the tank (the bottom of the filler neck). Do not overfill it.
- Wipe up any spilled gasoline.

While Operating

 Warning 
<p>Engine exhaust contains carbon monoxide, which is an odorless, deadly poison that can kill you.</p> <p>Do not run engine indoors or in an enclosed area.</p>

- The operator and passenger should remain seated whenever the sprayer is in motion. The operator should keep both hands on the steering wheel whenever possible, and the passenger should use the hand holds provided. Keep your arms and legs within the sprayer body at all times.
- Drive slower and turn less sharply when you are carrying a passenger. Remember your passenger may not be expecting you to brake or turn and may not be ready.
- Always watch out for and avoid low overhangs such as tree limbs, door jambs, and over-head walkways. Make sure there is enough room over head to easily clear the sprayer and your head.
- Failure to operate the sprayer safely may result in an accident, tip over of the sprayer, and serious injury or death. Drive carefully. To prevent tipping or loss of control:
 - Use extreme caution, reduce speed, and maintain a safe distance around sand traps, ditches, creeks, ramps, unfamiliar areas, or any areas that have abrupt changes in ground conditions or elevation.
 - Watch for holes or other hidden hazards.
 - Use extra caution when operating the sprayer on wet surfaces, in adverse weather conditions, at higher speeds, or with a full load. Stopping time and distance will increase with a full load.
 - Avoid sudden stops and starts. Do not go from reverse to forward or forward to reverse without first coming to a complete stop.
 - Slow down before turning. Do not attempt sharp turns or abrupt maneuvers or other unsafe driving actions that may cause a loss of sprayer control.
 - Before backing up, look to the rear and ensure that no one is behind you. Back up slowly.

- Watch out for traffic when you are near or crossing roads. Always yield the right of way to pedestrians and other vehicles. This sprayer is **not** designed for use on streets or highways. Always signal your turns or stop early enough so that other people know what you plan to do. Obey all traffic rules and regulations.
 - The electrical and exhaust systems of the sprayer can produce sparks capable of igniting explosive materials. Never operate the sprayer in or near an area where there is dust or fumes in the air which are explosive.
 - If you are ever unsure about safe operation, **stop work** and ask your supervisor.
 - Do not touch the engine or muffler while the engine is running or soon after it has stopped. These areas may be hot enough to cause burns.
 - If the machine ever vibrates abnormally, stop immediately, wait for all motion to stop, and inspect the sprayer for damage. Repair all damage before resuming operation.
 - Before getting off of the seat:
 - A. Stop the movement of the machine.
 - B. Place the range selector in Neutral and set the parking brake.
 - C. Turn the ignition key to Off.
 - D. Remove the ignition key.
- Note:** If the sprayer is stopped on an incline, block the wheels after getting off the sprayer.

Braking



- Slow down before you approach an obstacle. This gives you extra time to stop or turn away. Hitting an obstacle can damage the sprayer and its contents. More important, it can injure you and your passenger.
- Gross Vehicle Weight (GVW) has a major impact on your ability to stop and/or turn. Heavy loads and attachments make a sprayer harder to stop or turn. The heavier the load, the longer it takes to stop.
- Turf and pavement are much slipperier when they are wet. It can take 2 to 4 times as long to stop on wet surfaces as on dry surfaces. If you drive through standing water deep enough to get the brakes wet, they will not work well until they are dry. After driving through water, you should test the brakes to make sure they work properly. If they do not, drive slowly while putting light pressure on the brake pedal. This will dry the brakes out.
- When operating with a liquid in the tank, reduce your speed and allow for sufficient braking distance. Do not suddenly apply the brakes. Use extra caution on slopes.

- Be aware that heavy loads increase your stopping distance and reduce your ability to turn quickly without tipping over.

Operating on Hills and Rough Terrain

Operating the sprayer on a hill may cause tipping or rolling of the sprayer, or the engine may stall and you could lose headway on the hill. This could result in personal injury.

- Do not accelerate quickly or slam on the brakes when backing down a hill, especially with liquid in the tank.
- Never drive across a steep hill; always drive straight up or down or go around the hill.
- If the engine stalls or you begin to lose headway while climbing a hill, gradually apply the brakes and slowly back straight down the hill.
- Turning while traveling up or down hills can be dangerous. If you have to turn while on a hill, do it slowly and cautiously. Never make sharp or fast turns.
- Avoid stopping on hills, especially with liquid in the tank. Stopping while going down a hill will take longer than stopping on level ground. If the sprayer must be stopped, avoid sudden speed changes, which may initiate tipping or rolling of the sprayer. Do not slam on the brakes when rolling backward, as this may cause the sprayer to overturn.
- The Toro Company strongly recommends installing the optional ROPS Kit when operating on hilly terrain. If you install a ROPS, always wear the seat belt when driving the sprayer.
- Liquid loads will shift when turning, going up or down hills, suddenly changing speeds, or while driving over rough surfaces. Shifting loads can cause the sprayer to tip over. Reduce your speed in these conditions.

Warning

Sudden changes in terrain may cause abrupt steering wheel movement, possibly resulting in hand and arm injuries.

- **Reduce your speed when operating on rough terrain and near curbs.**
- **Grip the steering wheel loosely around the perimeter. Keep your hands clear of the steering wheel spokes.**

- Before servicing or making adjustments to the machine, stop the engine, set the parking brake, and remove the key from the ignition to prevent someone from accidentally starting the engine.
- To make sure that the entire machine is in good condition, keep all nuts, bolts, and screws properly tightened.
- To reduce the potential for fire, keep the engine area free of excessive grease, grass, leaves, and accumulation of dirt.
- Never use an open flame to check the level or leakage of fuel or battery electrolyte.
- If the engine must be running to perform a maintenance adjustment, keep your hands, feet, clothing, and any parts of your body away from the engine and any moving parts. Keep everyone away.
- Do not use open pans of fuel or flammable cleaning fluids when cleaning parts.
- **Do not adjust** the ground speed governor. To ensure safety and accuracy, have an Authorized Toro Distributor check the ground speed.
- Keep your body and hands away from pin hole leaks or nozzles that eject high pressure fluid. Use cardboard or paper to find leaks. Fluid escaping under pressure can penetrate skin and cause injury requiring surgery within a few hours by a qualified surgeon or gangrene may result.
- If major repairs are ever needed or assistance is required, contact an Authorized Toro Distributor.
- To be sure of optimum performance and safety, always purchase genuine Toro replacement parts and accessories. Replacement parts and accessories made by other manufacturers could be dangerous. Altering this sprayer in any manner that may affect sprayer operation, performance, durability, and may result in injury or death. Such use could void the product warranty.

Maintenance

- Only permit qualified and authorized personnel to maintain, repair, adjust, or inspect the sprayer.

Safety and Instruction Decals



Safety decals and instructions are easily visible to the operator and are located near any area of potential danger. Replace any decal that is damaged or lost.



41176

- 1. No power
- 2. Engine—ignition
- 3. Engine—start

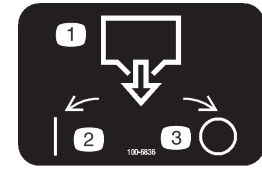

100-6836

- 1. Tank drain
- 2. On
- 3. Off



26-7170

- 1. Recycle



85-4730



54-0890



65-3090



87-0430



71-3730



93-6687

- 1. Do not step here.



87-0450



94-7132

WARNING

FAILURE TO OBEY THE SAFETY WARNINGS MAY RESULT IN INJURY TO YOU OR OTHERS.

THIS VEHICLE IS OF SUFFICIENT SIZE AND WEIGHT TO CAUSE SERIOUS INJURY IN CASE OF UPSET OR COLLISION.

BEFORE OPERATING VEHICLE:

- READ AND UNDERSTAND OPERATOR'S MANUAL LOCATED BEHIND SEAT.
- DO NOT EXCEED PAYLOAD CAPACITY OF VEHICLE AND/OR TORO ACCESSORIES OR PERMIT PASSENGER ANY PLACE ON VEHICLE EXCEPT SEAT.
- USE HAND HOLDS WHERE APPLICABLE.
- PLACE HEAVY LOADS FORWARD OF REAR AXLE. UNBALANCED OR TOP HEAVY LOADS CAN CAUSE UPSET.

WHILE OPERATING VEHICLE:

- REMAIN SEATED AND USE BOTH HANDS FOR STEERING.
- KEEP ARMS AND LEGS WITHIN VEHICLE BODY.
- AVOID SUDDEN STARTS AND STOPS.
- SUDDEN SHARP TURNS CAN CAUSE UPSET.
- REGULATE SPEED TO MEET ROAD AND WEATHER CONDITIONS.
- DO NOT OPERATE IN OR NEAR AN EXPLOSIVE ENVIRONMENT.
- IF A MALFUNCTION OCCURS, CEASE OPERATION. DO NOT OPERATE VEHICLE UNTIL CONDITION IS CORRECTED.

BEFORE LEAVING VEHICLE:

- TURN IGNITION TO "OFF" POSITION, REMOVE KEY.
- APPLY PARKING BRAKE; PARKING BRAKE IS NOT AUTOMATICALLY APPLIED.

87-0580

87-0580



94-7171



94-7172

WARNING

VEHICLE LOAD AND TURF CONDITIONS AFFECT BRAKE PERFORMANCE. FAILURE TO OPERATE VEHICLE PROPERLY COULD RESULT IN PERSONAL INJURY.

AVOID HIGH SPEEDS OR ABRUPT STOPS ON SLOPES AND WET TURF.

SEE OPERATOR'S MANUAL FOR ADDITIONAL INFORMATION.

94-7176

94-7176



92-0479

WARNING

- LEAVING SEAT WHILE VEHICLE IS IN MOTION COULD RESULT IN SERIOUS INJURY OR DEATH.
- ALWAYS ALLOW VEHICLE TO COME TO A COMPLETE STOP BEFORE EXITING OR BOARDING VEHICLE.

95-2136

95-2136

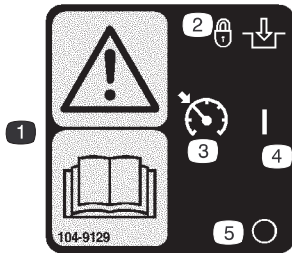

104-9129

- | | |
|--|-------------------|
| 1. Warning—read the <i>Operator's Manual</i> . | 3. Cruise control |
| 2. Lock and engage | 4. On |
| | 5. Off |

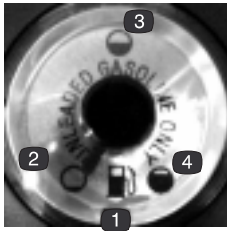

100-8386

- | | |
|----------|--------------|
| 1. Fuel | 3. Half-full |
| 2. Empty | 4. Full |



87-0570

- Warning—read the *Operator's Manual*.
- Electric shock hazard, overhead power lines—watch for overhead power lines.
- Crushing hazard, boom—keep bystanders a safe distance from the machine.

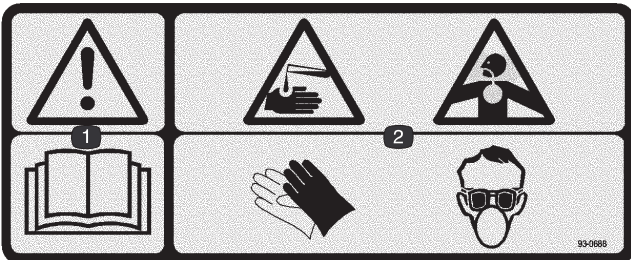

93-0688

- Warning—read the *Operator's Manual*.
- Caustic liquid/chemical burn and toxic gas inhalation hazards—wear hand, skin, eye, and respiratory protection.

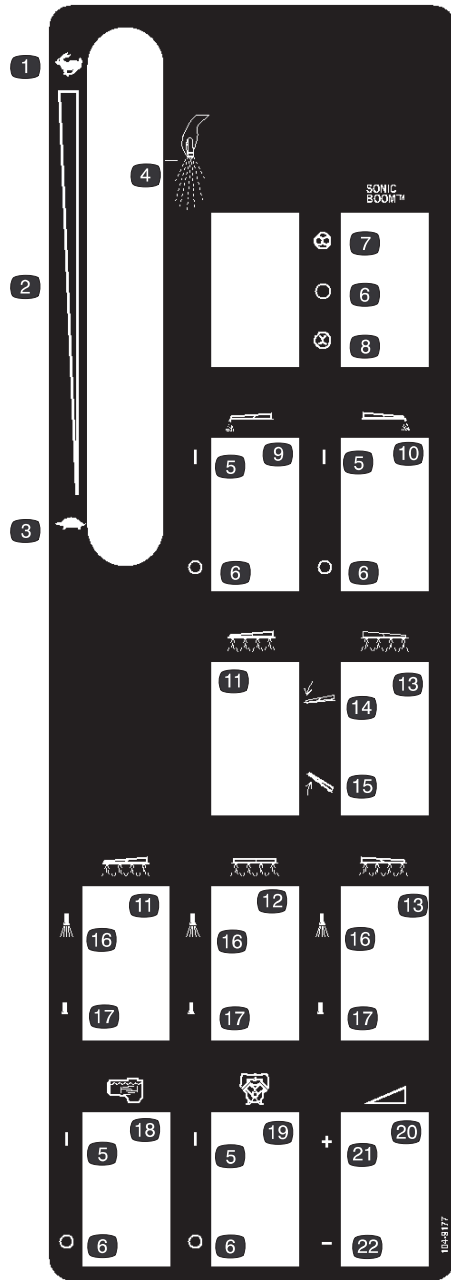

104-9177

- | | |
|--------------------------------|---|
| 1. Fast | 12. Center boom |
| 2. Continuous variable setting | 13. Right boom |
| 3. Slow | 14. Lower the boom. |
| 4. Spray | 15. Raise the boom. |
| 5. On | 16. Spray on |
| 6. Off | 17. Spray off |
| 7. Automatic | 18. Agitation |
| 8. Manual | 19. Pump |
| 9. Left boom foam marker | 20. Continuous variable setting, spray pressure |
| 10. Right boom foam marker | 21. Increase |
| 11. Left boom | 22. Decrease |



106-4970

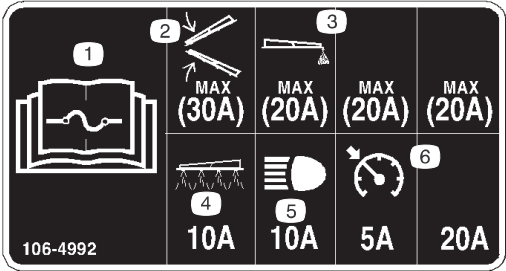

106-4992

1. Read the *Operator's Manual* for information on fuses.
2. Boom lift
3. Foam marker
4. Spray system
5. Headlights
6. Cruise control

Specifications

Note: Specifications and design are subject to change without notice.

Base weight	1750 lb (794 kg)
Weight with standard spray system, empty, with operator	2540 lb (1152.6 kg)
Weight with standard spray system, full, with operator	5040 lb (2287 kg)
Maximum gross vehicle weight (GVW) (on level ground)	6040 lb (2741 kg)
Tank capacity	300 US gallons (1135.6 L)
Overall width with standard spray system	72 inches (183 cm)
Overall length with standard spray system	136 inches (345 cm)
Overall height with standard spray system to the top of the tank	57.5 inches (146 cm)
Ground clearance	6.5 inches (16.5 cm)
Wheel base	78 inches (198 cm)



Optional Equipment

The Toro Company has optional equipment and accessories that you can purchase separately and install on your sprayer. Contact your Authorized Service Dealer for a complete list of optional equipment that is currently available for your sprayer.

Setup

Note: Determine the left and right sides of the machine from the normal operating position.

To use the sprayer, **you must obtain and install a boom kit and nozzles**. Contact your Authorized Toro Distributor for information on the available boom kits and accessories. After you install your booms and nozzles and before using the sprayer for the first time, adjust the boom bypass valves so that the pressure and application rate remains the same for all booms when you turn one or more booms off. Refer to Adjusting the Boom Bypass valves, page 20.

 Caution 	
<p>Without a boom kit installed, the sprayer may spray chemicals out of the boom valves, possibly injuring bystanders or causing property damage.</p> <p>Do not operate the sprayer without a boom kit and nozzles installed.</p>	

Loose Parts

Note: Use the chart below to verify that all parts have been shipped.

Description	Qty.	Use
90 degree fitting	1	Install the anti-siphon fill receptacle.
Quick coupler	1	
Hose adapter	1	
Fill receptacle bracket	1	
Flange nut, 5/16 inch	1	
Hairpin cotters	2	
Key	2	Use in the ignition switch.
Operator's Manual	1	Read before operating the machine.
Engine Operator's Manual	1	
Operator Video	1	Watch before operating the machine.
Parts Catalog	1	Use for ordering replacement parts.
Registration Card	1	Complete and return to Toro.
Predelivery Inspection Form	1	Complete and file in your customer history portfolio.

Installing the Anti-siphon Fill Receptacle

1. Remove the rubber cap from the stud on the tank strap (Fig. 2).

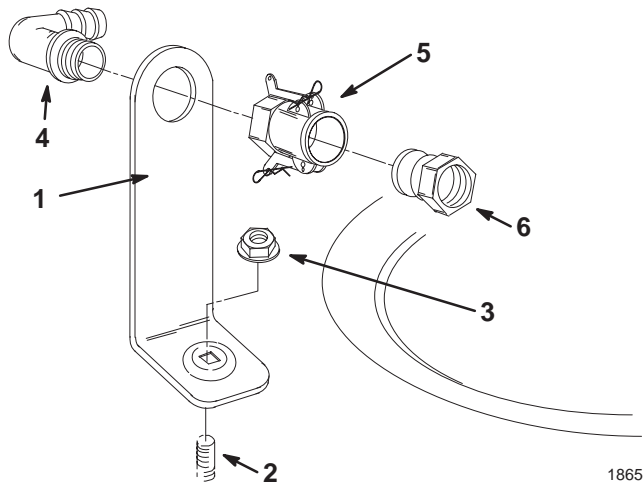

Figure 2

- | | |
|----------------------------|----------------------------|
| 1. Fill receptacle bracket | 4. 90 degree elbow fitting |
| 2. Stud | 5. Quick coupler |
| 3. Flange nut, 5/16 inch | 6. Hose adapter |

2. Place the fill receptacle bracket over the stud and secure it with a flange nut (5/16 inch) (Fig. 2).

3. Place the threaded end of the 90 degree elbow fitting through the bracket and thread the quick coupler onto it, securing it to the bracket (Fig. 2).

Note: Install the elbow fitting with the open end pointing toward the tank opening so the water will arc into the tank when you fill it.

4. Install the hose adapter into the quick coupler (Fig. 2).

5. Lock the adapter into place by swinging the levers toward the adapter and then secure them with the hairpin cotters.

Before Operating

Checking the Engine Oil

The engine is shipped with oil in the crankcase; however, the level of oil must be checked before you first start the engine and after you have run it.

1. Position the sprayer on a level surface, set the parking brake, stop the pump, stop the engine, and remove the ignition key.

2. Remove the dipstick, located under the passenger seat, and wipe it with a clean rag (Fig. 3). Insert the dipstick into the tube and make sure it is seated fully. Remove the dipstick and check the oil level.



Figure 3

1. Dipstick

3. If the oil level is low, add oil as follows:

- A. Remove the access plug in the wall behind the engine (Fig. 4).



Figure 4

1. Oil access plug

- B. Remove the filler cap from the valve cover (Fig. 5) and pour oil into the opening until the oil level is up to the Full mark on the dipstick.

Important Refer to Servicing Engine Oil, page 26, for the proper oil type and viscosity. Add the oil slowly and check the level often during this process. **Do not overfill.**



Figure 5

1. Oil filler cap

- C. Install the filler cap and access plug.

4. Install the dipstick firmly in place.

Checking the Tire Pressure

Check the tire pressure every 8 hours or daily to ensure proper levels. Fill the tires to 18 psi (124 kPa). Also, check the tires for wear or damage.

Adding Fuel

! **Danger** !

In certain conditions, gasoline is extremely flammable and highly explosive. A fire or explosion from gasoline can burn you and others and can damage property.

- Fill the fuel tank outdoors, in an open area, when the engine is cold. Wipe up any gasoline that spills.
- Do not fill the fuel tank completely full. Add gasoline to the fuel tank until the level is 1 inch (25 mm) below the bottom of the filler neck. This empty space in the tank allows gasoline to expand.
- Never smoke when handling gasoline and stay away from an open flame or where gasoline fumes may be ignited by a spark.
- Store gasoline in an approved container and keep it out of the reach of children. Never buy more than a 30-day supply of gasoline.
- Always place gasoline containers on the ground away from your sprayer before filling.
- Do not fill gasoline containers inside a vehicle or on a truck or trailer bed because interior carpets or plastic truck bed liners may insulate the container and slow the loss of any static charge.
- When practical, remove gas-powered equipment from the truck or trailer and refuel the equipment with its wheels on the ground.
- If this is not possible, then refuel such equipment on a truck or trailer from a portable container, rather than from a gasoline dispenser nozzle.
- If a gasoline dispenser nozzle must be used, keep the nozzle in contact with the rim of the fuel tank or container opening at all times until fueling is complete.

Recommended Gasoline

Use fresh, clean, **unleaded** regular gasoline suitable for automotive use (87 pump octane minimum). Leaded gasoline may be used if unleaded regular is not available.

Important Never use gasoline containing **methanol**, gasoline containing more than 10% ethanol, gasoline additives, or white gas because engine fuel system damage could result.

Filling the Fuel Tank

The fuel tank capacity is approximately 10.6 US gallons (40 L).

Note: The fuel tank cap contains a gauge which shows the fuel level; check it frequently.

1. Position the sprayer on a level surface, set the parking brake, stop the pump, stop the engine, remove the ignition key, and allow the engine to cool.
2. Clean the area around the fuel tank cap and remove it (Fig. 6).

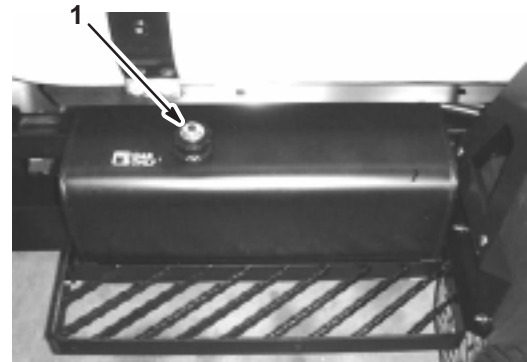

Figure 6

1. Fuel tank cap

3. Fill the tank to about one inch below the top of the tank, (bottom of the filler neck). This space in the tank allows gasoline to expand. **Do not overfill.**
4. Install the fuel tank cap securely.
5. Wipe up any fuel that may have spilled.

Checking the Coolant Level

! **Caution** !

If the engine has been running, the coolant may be hot and pressurized. If you open the radiator cap when the coolant is hot, it could spray out and severely burn you or bystanders.

Allow the engine to cool for at least 15 minutes before opening the radiator cap.

1. Position the sprayer on a level surface, set the parking brake, stop the pump, stop the engine, and remove the ignition key.
2. When the engine is cool, remove the radiator cap (Fig. 7) and check the coolant level.

The coolant should be 3/4 to 1-1/2 inches (2 to 4 cm) below the bottom of the filler neck.

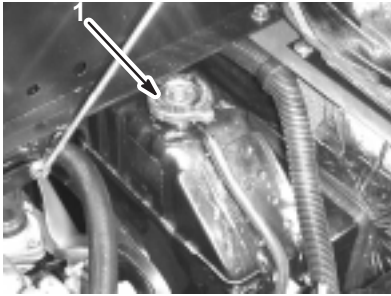

Figure 7

1. Radiator cap

3. If the coolant is low, add a solution of 50% water and 50% permanent ethylene glycol antifreeze.

Important Do not use water only or an alcohol/methanol based coolant.

4. Install and secure the radiator cap.

Checking the Hydraulic Fluid

1. Position the sprayer on a level surface, set the parking brake, stop the pump, stop the engine, and remove the ignition key.
2. Clean the area around the hydraulic oil tank cap and remove it (Fig. 8).

Important Be very careful not to get dirt or other contaminants into the opening when checking the oil.

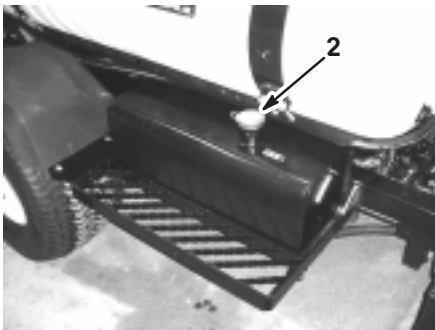

Figure 8

1. Hydraulic oil tank cap

3. Check the oil level by looking into the opening.

The oil should be 2 inches (5 cm) below the bottom of the filler neck.

4. If the oil is low, fill the tank with Mobil 424 (Mobil 15M) hydraulic fluid or equivalent.
5. Install and secure the hydraulic oil tank cap.

Checking the Brakes

Before starting the sprayer, lightly press the brake pedal. If the pedal travels more than 1 inch (2.5 cm) before you feel resistance, adjust the brakes; refer to Adjusting the Brakes, page 33.



Warning



If you operate the sprayer with poorly adjusted or worn brakes you could lose control of the sprayer, resulting in serious injury or death to you or bystanders.

Always check the brakes before operating the sprayer and keep them properly adjusted and repaired.

Filling the Fresh Water Tank

The sprayer is equipped with a fresh water tank (Fig. 9) for washing chemicals off of your skin, eyes, or other surfaces in the case of accidental exposure. Always fill the fresh water tank with clean water before handling or mixing any chemicals.

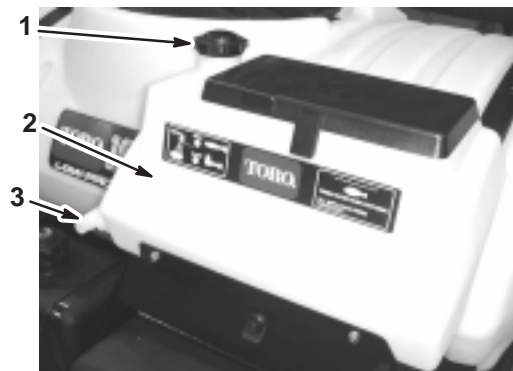

Figure 9

1. Filler cap

2. Fresh water tank

3. Spigot

To open the fresh water tank spigot, turn the lever on the spigot toward the front of the sprayer.

Operation

Note: Determine the left and right sides of the machine from the normal operating position.

Think Safety First

Please carefully read all of the safety instructions and decals in the safety section. Knowing this information could help you or bystanders avoid injury.

Vehicle Controls

Traction Pedal

The traction pedal (Fig. 10) controls the movement of the machine, both forward and reverse. Using the heel and tow of the right foot, press the top of the pedal to move forward or the bottom of the pedal to move in reverse. Release the pedal to slow and stop.

Important Ensure that you allow the sprayer to come to a stop before switching between Forward and Reverse.

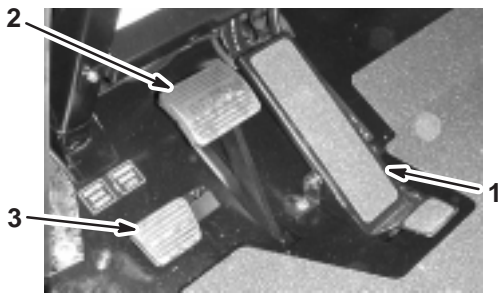

Figure 10

- 1. Traction pedal
- 2. Brake pedal
- 3. Parking brake pedal

The further you press the pedal in either direction, the faster the sprayer will travel. To obtain maximum forward speed, set the throttle lever to the Fast position and press the traction pedal all the way forward.

To obtain maximum power with a full tank or when traveling up a hill, set the throttle lever in the Fast position and drive slowly so that the engine remains at a high rpm.

Brake Pedal

Use the brake pedal to stop or slow the sprayer (Fig. 10).

Warning

If you operate the sprayer with poorly adjusted or worn brakes you could lose control of the sprayer, resulting in serious injury or death to you or bystanders.

Always check the brakes before operating the sprayer and keep them properly adjusted and repaired.

Parking Brake

The parking brake is a pedal to the left of the brake (Fig. 10). Engage the parking brake whenever you plan on leaving the seat to prevent accidental movement of the sprayer. To engage the parking brake, press the brake pedal and, while holding the brake, press the parking brake pedal. To disengage, press and release the brake pedal. If the sprayer is parked on a steep grade, apply the parking brake and place blocks at the downhill side of the wheels.

Choke Control

The choke control is a small knob between the seats under the control panel (Fig. 11). To start a cold engine, pull the choke control out. After the engine starts, regulate the choke to keep the engine running smoothly. As soon as possible, push the control in. A warm engine requires little or no choking.



Figure 11

- 1. Choke control

Throttle Lever

The throttle lever, located on the control panel between the seats (Fig. 12), controls the speed of the engine. Push the lever forward to increase the engine speed and pull it rearward to decrease engine speed. Use the Spray position when spraying for optimal results.

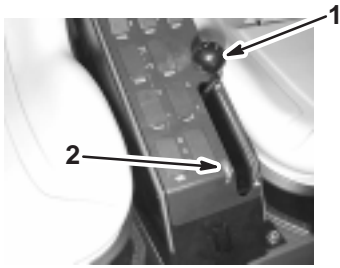

Figure 12

1. Throttle lever 2. Spray position

Ignition Switch

The ignition switch (Fig. 13), used to start and stop the engine, has 3 positions: Stop, Run, and Start. Rotate the key clockwise to the Start position to start the engine and release it to the Run position when started. Rotate the key to the Stop position to stop the engine.

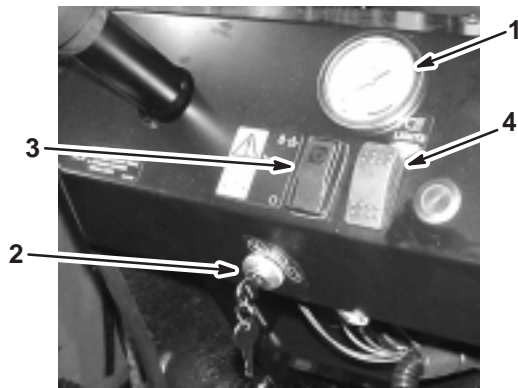

Figure 13

1. Pressure gauge 3. Cruise control switch
2. Ignition switch 4. Headlight switch

Pressure Gauge

The pressure gauge (Fig. 13) indicates the pressure of the spray system. Refer to Pressure Gauge, page 20, for more information.

Cruise Control Switch

The cruise control switch (Fig. 13) sets the forward speed of the sprayer and holds it without pressure on the traction pedal. Set the cruise control and maintain a speed as follows:

1. Drive forward and attain the speed you desire; refer to Driving the Sprayer, page 17.
2. Press the top of the cruise control switch.

The light on the switch illuminates.

3. Take your foot off of the traction pedal.

The sprayer will maintain the speed you set.

To release the cruise control, do one of the following:

- Press the top of the cruise control switch.
- Press the brake pedal.

The light on the switch turns off and the traction control returns to the traction pedal.

Caution

If you press the switch to turn off the cruise control and do not have your foot on the traction pedal, the traction unit may come to a sudden stop and cause you to lose control, possibly injuring you or bystanders.

Ensure that you have your foot on the traction pedal when you disengage the cruise control using the switch.

Headlight Switch

Toggle the switch to operate the headlights (Fig. 13). Push it forward to turn the lights on and rearward to turn them off.

Hour Meter

The hour meter (Fig. 11) indicates the total number of hours the engine has run. The hour meter starts to function whenever the key is turned to the Run position.

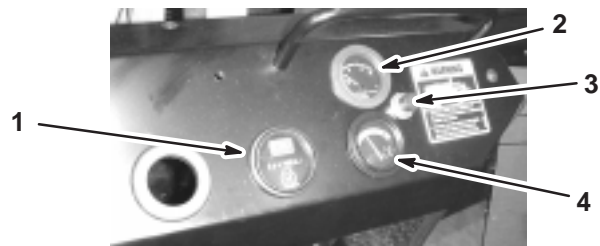

Figure 14

1. Hour meter 4. Coolant temperature gauge
2. Voltmeter
3. Engine oil pressure light

Voltmeter

The voltmeter (Fig. 14) indicates the level of charge in the battery. When the battery is fully charged, the voltmeter will read in the center of the dial when the key is in the Run position with the engine off. When the engine is running the voltmeter needle should be to the right.

Engine Oil Pressure Warning Light

The engine oil pressure warning light (Fig. 14) illuminates when the engine oil pressure is dangerously low. If the light illuminates, stop the engine immediately and correct the problem before starting the engine again.

Coolant Temperature Gauge

The coolant temperature gauge (Fig. 14) indicates the temperature of the coolant. This gauge only functions when the ignition key is in the Run position. When the engine is running the gauge needle should advance to and remain in the green range of the dial.

If the needle enters the red range, the engine is over heating. Stop the sprayer and allow the engine to idle in neutral for 2 minutes, then stop the engine, allow it to cool, and determine the cause of the overheating.

⚠Caution⚠

If the engine has been running, the coolant may be hot and pressurized. If you open the radiator cap when the coolant is hot, it could spray out and severely burn you or bystanders.

Allow the engine to cool for at least 15 minutes before opening the radiator cap.

Fuel Gauge

The fuel gauge (Fig. 15) shows the amount of fuel in the tank.



Figure 15

1. Fuel gauge

Pre-Starting Checks

Check the following items each time you begin using the sprayer for the day:

- Check the tire pressure.

Note: These tires are different than car tires; they require less pressure to minimize turf compaction and damage.

- Check all fluid levels and add the appropriate amount of specified fluids, if any are found to be low.
- Check the brake pedal operation.
- Ensure that the lights are working.
- Turn the steering wheel to the left and right to check steering response.
- With the engine off, check for oil leaks, loose parts, and any other noticeable malfunctions.

If any of the above items are not correct, notify your mechanic or check with your supervisor before taking the sprayer out for the day. Your supervisor may want you to check other items on a daily basis, so ask what your responsibilities are.

Starting the Engine

1. Sit in the operator's seat, insert the key into the ignition switch, and rotate the key clockwise to the Run position.
2. Press the brake.
3. Ensure that the pump switch is in the Off position.
4. Move the throttle to the Slow position.
5. If the engine is cold, pull the choke knob.

Important Do not use the choke if the engine is warm.

6. Turn the key to the Start position until the engine starts.

Important Do not hold the key in the Start position for more than 10 seconds. If the engine has not started after 10 seconds, wait 1 minute before trying again. Do not attempt to push or tow the sprayer to start the engine.

7. Once the engine starts, push the choke knob in slowly.
8. Adjust the throttle as needed.

Driving the Sprayer

1. Press the traction pedal forward to drive forward or rearward to drive in reverse.

Important Ensure that you allow the sprayer to come to a stop before switching between Forward and Reverse.

2. To slowly stop the sprayer, release the traction pedal.
3. To stop quickly, press the brake pedal.

Note: Stopping distance may vary depending on the sprayer load and speed.

Stopping the Engine

1. Press the brake to stop the sprayer.
2. With the brake pressed, press the parking brake pedal to lock the brake.
3. Move the throttle lever to the Slow position.
4. Turn the ignition key to the Stop position.
5. Remove the key from the switch to prevent someone from accidentally starting the engine.

New Sprayer Break-In

To provide proper performance and long sprayer life, follow these guidelines for the first 100 operating hours:

- Check the fluid and engine oil levels regularly and be alert for indications of overheating in any component of the sprayer.
- After starting a cold engine, let it warm up for about 15 seconds before accelerating.
- Avoid hard braking situations for the first several hours of new sprayer break-in operation. New brake linings may not be at optimum performance until several hours of use has caused the brakes to become burnished (broken-in).
- Avoid racing the engine.
- Vary the sprayer speed during operation. Avoid fast starts and quick stops.
- Refer to the Maintenance section for any special low hour checks.

Transporting the Sprayer

For moving the sprayer long distances, use a trailer. Secure the sprayer to the trailer. Figures 16 and 17 illustrate the tie-down points.

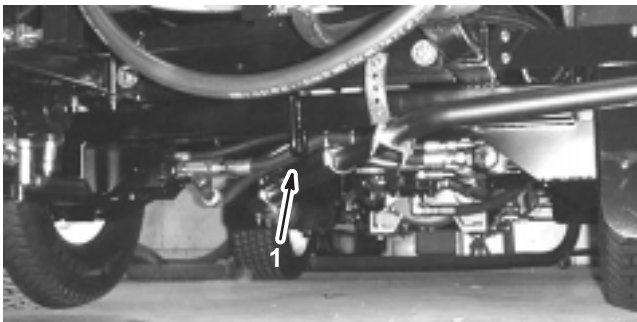

Figure 16

1. Rear tie down point

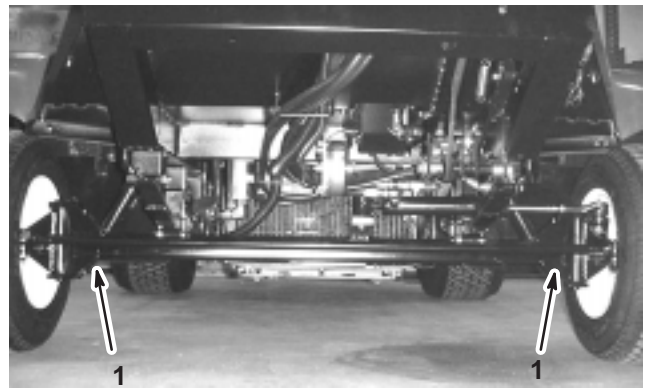



Figure 17

1. Front tie down points

Towing the Sprayer

In case of an emergency, the sprayer can be towed for a short distance after you open the tow valve. However, we do not recommend this as a standard procedure.

	Warning	
Towing at excessive speeds could cause a loss of steering control, resulting in personal injury.		
Never tow the sprayer faster than 3 mph (4.8 kph).		

Towing the sprayer is a two person job. If the machine must be moved a considerable distance, transport it on a truck or trailer; refer to Transporting the sprayer, page 18.

1. Rotate the tow valve (Fig. 18) 90 degrees in either direction to open it.

Important If you do not open the tow valve before towing the sprayer you will damage the transmission.

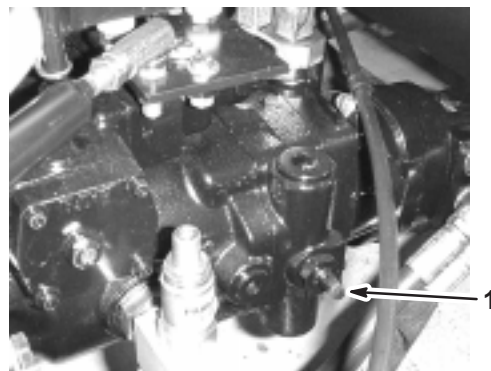

Figure 18

1. Tow valve
2. Affix a tow line to the frame.

3. Release the parking brake.
4. Tow the sprayer at less than 3 mph (4.8 kph).
5. When finished, close the tow valve and torque it to no more than 5 to 8 ft-lb (7 to 11 N-m).

Sprayer Controls and Components

Master Boom Switch

The master boom switch allows you to start or stop the spray operation. Press the switch with your foot to enable or disable the spray system (Fig. 19).

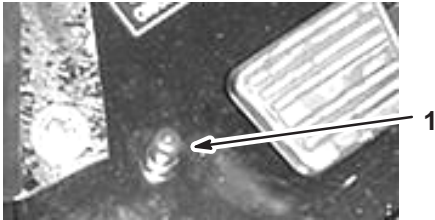

Figure 19

1. Master boom switch

Boom Switches

The boom switches are located at the front of the control panel to the right of the seat (Fig. 20). Toggle each switch forward to turn the corresponding boom section on and rearward to turn each off. When the switch is turned on, a light on the switch illuminates. These switches will only affect the spray system when the master boom switch is on.

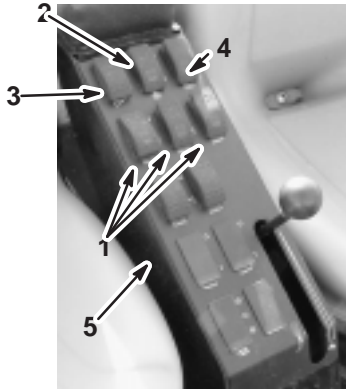

Figure 20

1. Boom switches
2. Pump switch
3. Application rate switch
4. Agitation switch
5. Empty plugs (picture shows the optional boom lift switches installed)

Pump Switch

The pump switch is located on the control panel to the right of the seat (Fig. 20). Toggle this switch forward to run the pump or rearward to stop the pump. When the switch is turned on, a light on the switch illuminates.

Application Rate Switch

The application rate switch is located on the control panel to the right of the seat (Fig. 20). Press and hold the switch forward to increase the spray system pressure, or press and hold it rearward to decrease pressure.

Agitation Switch

The agitation switch is located on the control panel to the right of the seat (Fig. 20). Toggle this switch forward to turn agitation in the tank on or rearward to stop the agitation. When the switch is turned on, a light on the switch illuminates. For agitation to work, the pump must be on and the engine must be running above an idle. The agitation valve is located behind the tank (Fig. 21).

Boom Lift, Sonic Boom, and Foam Marker Switch Locations

If you install the electric boom lift, sonic boom, and foam marker kit, you will add switches to the control panel for controlling their operation. The sprayer comes with plastic plugs in these locations.

Boom Valves

These valves turn the three booms on or off (Fig. 21). If you ever need to manually turn off a boom, rotate the knob on the valve clockwise to turn the valve off or counterclockwise to turn it on.

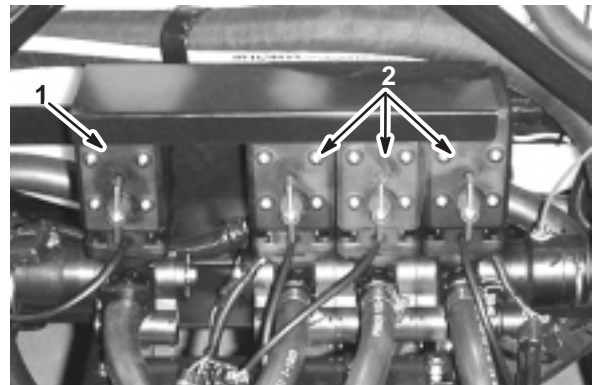

Figure 21

1. Agitation valve
2. Boom valves

Boom Bypass Valves

The boom bypass valves redirect the fluid flow for a boom to the tank when you turn off the boom section. You can adjust these valves to ensure that the boom pressure remains constant no matter how many booms are on. Refer to Adjusting the Boom Bypass Valves, page 20.

Pressure Gauge

The pressure gauge is located on the dash (Fig. 13). This gauge shows the pressure of the fluid in the system in psi and kPa.

Pump

The pump is located near the back of the tank on the left side (Fig. 22).

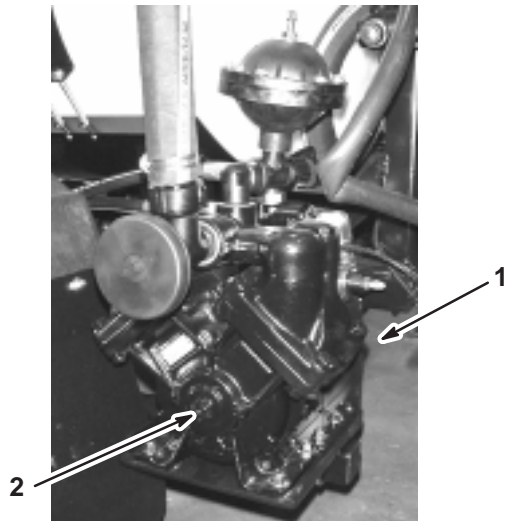

Figure 22

1. Pump
2. Grease fitting

Tank Drain Knob

The tank drain knob is located on top of the tank (Fig. 23). Turn the knob counterclockwise to drain the tank.

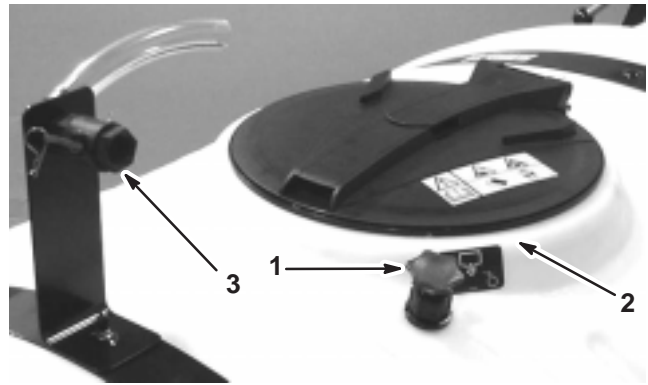

Figure 23

1. Tank drain knob
2. Tank cover
3. Anti-siphon fill receptacle

Tank Cover

The tank cover is located in the center of the top of the tank (Fig. 23). To open it, turn off the engine, then turn the front half of the cover to the left and swing it open. You can remove the strainer inside for cleaning. To seal the tank, close the cover and rotate the front half toward the right.

Anti-siphon Fill Receptacle

To the front of the tank cover is a hose receptacle with a threaded fitting and a 90 degree barbed fitting and tube which you can direct toward the tank opening (Fig. 23). This receptacle allows you to connect a water hose to it and fill the tank with water without contaminating the hose with the chemicals in the tank.

Adjusting the Boom Bypass Valves

Important If you have the Pro Control™ Spray System installed, the boom valves must be closed.

After you install your booms and nozzles and before using the sprayer for the first time, adjust the boom bypass valves so that the pressure and application rate remains the same for all booms when you turn one or more booms off.

Select an open flat area to perform this procedure.

1. Fill the spray tank with clean water.
2. Put the extension booms down, if installed.
3. Set the parking brake and start the engine .
4. Move the throttle lever to the Spray position.
5. Set the pump switch to the On position to start the pump.

6. Set all three boom switches and the master boom switch to the On position.
7. Use the application rate switch to adjust the pressure as read on the pressure gauge until it is in the range for the nozzles you installed on the booms (typically 40 psi).
8. Record the reading on the pressure gauge.
9. Turn off one of the booms using the appropriate boom switch.
10. Adjust the boom bypass valve (Fig. 24) under the boom control valve for the boom you turned off until the pressure reading on the gauge is the same as it was in step 7.

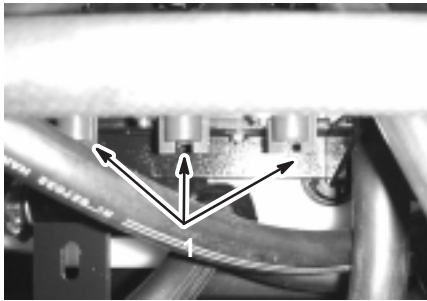

Figure 24

1. Boomy bypass valves

11. Turn the boom on.
12. Repeat steps 9 through 11 for the other booms.
13. Drive the sprayer at the desired speed while spraying and turn each boom off individually. The pressure on the gauge should remain constant.

Operating the Sprayer

To operate the sprayer you first fill the spray tank, then apply the solution to the work area, and finally clean the tank. It is important that you complete all three of these steps in succession to avoid damaging the sprayer. For example, do not mix and add chemicals in the spray tank at night and then spray in the morning. This would lead to separation of the chemicals and possible damage to the sprayer components.



Caution



Chemicals are hazardous and can cause personal injury.

- **Read the directions on the chemical labels before handling the chemicals and follow all manufacturer recommendations and precautions.**
- **Keep chemicals away from your skin. Should contact occur, wash the affected area thoroughly with soap and clean water.**
- **Wear goggles and any other protective equipment recommended by the chemical manufacturer.**

Filling the Spray Tank

Important Ensure that the chemicals you will be using are compatible for use with Viton (see the manufacturer's label; it should indicate if it is not compatible). Using a chemical that is not compatible with Viton will degrade the o-rings in the sprayer, causing leaks.

1. Stop the sprayer on a level surface, stop the engine, and set the parking brake.
2. Determine the amount of water needed to mix the amount of chemical you need as prescribed by the chemical manufacturer.
3. Open the lid on the spray tank.
4. Add 3/4 of the required water to the spray tank using the anti-siphon fill receptacle.

Important Always use fresh clean water in the spray tank. Do not pour concentrate into an empty tank.

5. Start the engine and move the throttle lever to the Spray position.
6. Set the pump switch to the On position.
7. Set the agitation switch to the On position.
8. Add the proper amount of chemical concentrate to the tank, as directed by the chemical manufacturer.

Important If you are using a wettable powder, mix the powder with a small amount of water to form a slurry before adding it to the tank

9. Add the remaining water to the tank.

Applying Chemicals

Important In order to ensure that your solution remains well mixed, use the agitation feature whenever you have solution in the tank. For agitation to work, the pump must be on and the engine must be running above an idle.

Note: This procedure assumes that the pump is on from the Filling the Spray Tank procedure.

1. Set the master boom switch to the Off position.
2. Swing the booms into position.
3. Set the individual boom switches, as needed, to the On positions.
4. Drive to the location where you will be spraying.
5. Use the application rate switch to achieve the desired pressure as indicated in the *Nozzle Selection Guide* provided with the sprayer.
6. Drive at the desired speed and then set the master boom switch to the On position to begin spraying.

Note: When the tank is nearly empty, the agitation may cause foaming in the tank. In this case, turn the agitation switch off. Alternatively, you can use an anti-foaming agent in the tank.

7. When finished spraying, set the master boom switch to the Off position to turn off all booms, then set the pump switch to the Off position.

Operating Tips

- Do not overlap areas that you have previously sprayed.
- Watch for plugged nozzles. Replace all worn or damaged nozzles.
- Use the master boom switch to stop the spray flow before stopping the sprayer.
- You will obtain better results if the sprayer is moving when you turn the booms on.

Cleaning the Sprayer

Important You must always empty and clean the sprayer immediately after each use. Failure to do so may cause the chemicals to dry or thicken in the lines, clogging the pump and other components.

1. Stop the sprayer, set the parking brake, and turn off the engine.
2. Use the tank drain knob to drain any unused material from the tank and dispose of it according to local codes and the material manufacturer's instructions.
3. Fill the tank with at least 50 US gallons (190 L) of clean fresh water and close the cover.

Note: You can use a cleaning/neutralizing agent in the water as needed. On the final rinse, use only clean, clear water.

4. Start the engine and move the throttle lever to the Spray position.
5. Ensure that the agitation control valve is in the On position.
6. Set the pump switch to the On position and use the application rate switch to increase the pressure to a high setting.
7. Set the master boom switch and boom control switches to the On positions to begin spraying.
8. Allow all of the water in the tank to spray out through the nozzles.
9. Check the nozzles to ensure that they are all spraying correctly.
10. Set the master boom switch to the Off position, set the pump switch to the Off position, and stop the engine.
11. Repeat steps 3 through 10 at least **2 more times** to ensure that the spray system is fully cleaned.

Important You must always complete this procedure at least 3 times to ensure that the spray system is fully clean, preventing damage to the system.

12. Clean the strainer; refer to Cleaning the Suction Strainer, page 38.

Important If you used wettable powder chemicals, clean the strainer after each tank.

13. Using a garden hose, rinse off the outside of the sprayer with clean water.
14. Remove the nozzles and clean them by hand. Replace damaged or worn nozzles.

Maintenance

Note: Determine the left and right sides of the machine from the normal operating position.

Recommended Maintenance Schedule

Maintenance Service Interval	Maintenance Procedure
8 hours	<ul style="list-style-type: none"> • Check the air filter, cap, and baffle for wear or damage. • Check the engine oil. • Check the tire pressure. • Check the engine coolant level • Check the hydraulic oil level • Clean the suction strainer³ • Initial break-in service only: check the fan and alternator belts, torque the wheel lug nuts, replace the hydraulic oil filter, and change the rear planetary gearbox fluid.
50 hours	<ul style="list-style-type: none"> • Check the battery electrolyte level. • Check the battery cable connections. • Lubricate all grease fittings. • Initial break-in service only: change the engine oil (includes synthetic oil) and replace the engine oil filter.
100 hours	<ul style="list-style-type: none"> • Change the engine oil (includes synthetic oil).¹ • Replace the engine oil filter. • Check the cooling system hoses for wear or damage. • Service the air cleaner.² • Check the fan and alternator belts. • Inspect the condition and wear of the tires. • Torque the wheel lug nuts.
200 hours	<ul style="list-style-type: none"> • Check the front wheel toe-in. • Clean the radiator fins • Initial break-in service only: pack the front wheel bearings.
400 hours or yearly	<ul style="list-style-type: none"> • Change the spark plugs. • Change the hydraulic oil. • Replace the hydraulic oil filter. • Inspect the fuel lines. • Replace the fuel filters. • Change the rear planetary gearbox fluid. • Check the coolant (as directed by the manufacturer) and change if necessary. • Drain and clean the fuel tank. • Pack the front wheel bearings.

¹More often when operating in high temperatures

²More often in dusty, dirty conditions

³More often when using wettable powers

Important Refer to your engine operator's manual for additional maintenance procedures.

Daily Maintenance Checklist

Duplicate this page for routine use.

Maintenance Check Item	For the week of:						
	Mon.	Tues.	Wed.	Thurs.	Fri.	Sat.	Sun.
Check the brake and parking brake operation.							
Check the neutral lockout switch operation.							
Check the fuel level.							
Check the engine oil level.							
Check the hydraulic oil level.							
Check the coolant level.							
Inspect the air filter.							
Inspect the radiator and oil cooler for debris.							
Check any unusual engine noises.							
Check any unusual operating noises.							
Check the tire pressure.							
Check for fluid leaks.							
Check all hydraulic and fluid hoses for damage, kinks, or wear.							
Check the instrument operation.							
Check the accelerator operation.							
Clean the suction strainer.							
Lubricate all grease fittings. ¹							
Touch up any damaged paint.							

¹Immediately after **every** washing, regardless of the interval listed

Notation for Areas of Concern

Inspection performed by:		
Item	Date	Information
1		
2		
3		
4		
5		
6		
7		
8		
9		



Caution



If you leave the key in the ignition switch, someone could accidentally start the engine and seriously injure you or other bystanders.

Remove the key from the ignition and disconnect the wire(s) from the spark plug(s) before you do any maintenance. Set the wire(s) aside so that it does not accidentally contact the spark plug(s).

Jacking the Sprayer

Whenever the engine is run for routine maintenance and/or engine diagnostics, support the rear wheels of the sprayer 1 inch (25 mm) off of the ground with the rear axle on jack stands.



Danger



A sprayer on a jack may be unstable and slip off of the jack, injuring anyone beneath it.

- Do not start the engine while the sprayer is on a jack.
- Always remove the key from the ignition before getting off of the sprayer.
- Block the tires when the sprayer is on a jack.

The jacking point at the front of the sprayer is under the front axle, directly under the leaf springs (Fig. 25)

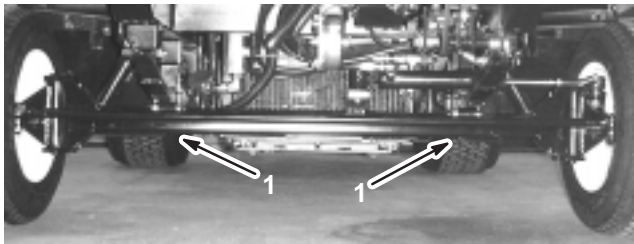

Figure 25

1. Front jacking points

The jacking point at the rear of the sprayer is on the rear frame support, between the angle welds (Fig. 26).

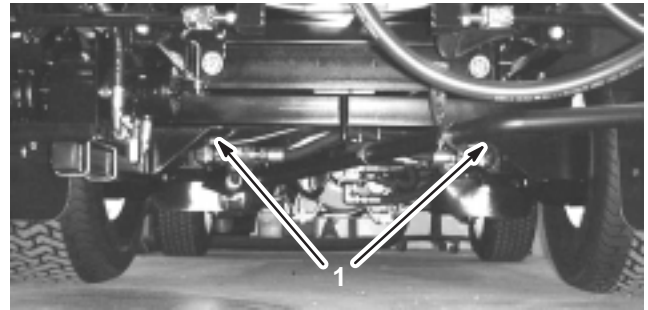

Figure 26

1. Rear jacking points

Inspecting the Wheels/Tires

Check the wheels to ensure that they are mounted securely after the first 1 to 4 operating hours and then every 100 hours thereafter. Torque the front bolts to 55–65 ft-lb (75–88 N·m) and the rear lug nuts to 85–100 ft-lb (115–135 N·m).

Check the tire condition at least every 100 hours of operation. Operating accidents, such as hitting curbs, can damage a tire or rim and also disrupt wheel alignment, so inspect tire condition after an accident.

Servicing the Air Cleaner

Check the air cleaner body for damage which could possibly cause an air leak. Ensure that the dust cap is sealing tightly of the air cleaner. Replace a damaged air cleaner body.

Squeeze the vacuator (Fig. 28) before each use to clear it of dust and debris.

Service the air cleaner filter every 100 hours.

Note: Service the air cleaner more frequently if operating conditions are extremely dusty or sandy.

Removing the Filter Element

1. Set the parking brake, stop the pump, stop the engine, and remove the ignition key.
2. Raise the passenger seat.
3. Open the air cleaner access door in front of the air cleaner (Fig.) by unscrewing and then lifting the latch.

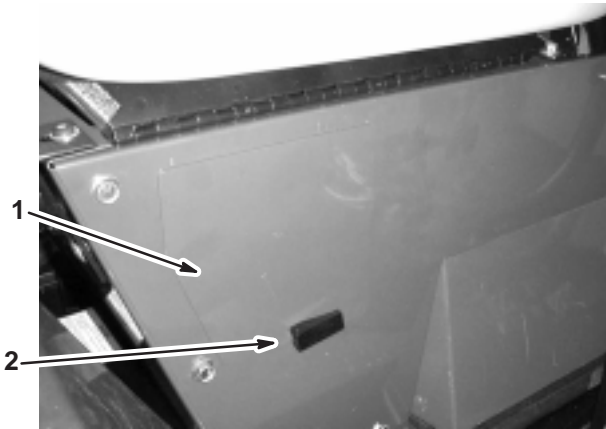

Figure 27

1. Air cleaner access door
2. Latch

4. Loosen the air cleaner strap securing the air cleaner cover to the air cleaner body (Fig. 28) and separate the cover from the body.

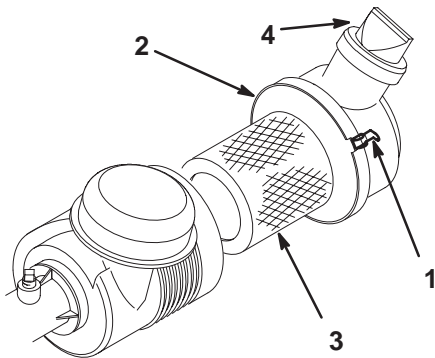

Figure 28

1. Air cleaner strap
2. Dust cap
3. Filter
4. Vacuator

5. Clean the inside of the air cleaner cover.
6. Gently slide the filter out of the air cleaner body to reduce the amount of dust dislodged. Avoid knocking the filter against the air cleaner body.
7. Inspect the filter and discard it if it is damaged.

Important Do not wash or reuse a damaged filter.

Cleaning the Filter Element

Clean the air filter using one of the following methods:

- Washing—wash the filter to remove fine dust and dirt embedded in the filter.
- Compressed air—clean the filter with low pressure compressed air if it has large particles or is not very dirty.

Washing method:

1. Prepare a solution of filter cleaner and water and soak the filter element about 15 minutes; refer to the directions on the filter cleaner carton for complete information.
2. After soaking the filter for 15 minutes, rinse it with clear water. The maximum water pressure must not exceed 40 psi to prevent damage to the filter element. Rinse the filter from clean side to dirty to side.
3. Allow the filter to air dry before installing it in the sprayer.

Compressed air method:

1. Blow the compressed air from inside to the outside of the dry filter element. Keep the air hose nozzle at least 2 inches (6 cm) from the filter and move the nozzle up and down while rotating the filter element.

Important To prevent damage to the filter element, do not exceed 25 psi air pressure.

2. Inspect for holes and tears by looking through the filter toward a bright light.

Installing the Filter Element

1. If you are installing a new filter, inspect it for shipping damage. Check the sealing end of the filter.

Important Do not install a damaged filter.

2. Insert the filter into the air cleaner body. Ensure that the filter is sealed properly by applying pressure to the outer rim of the filter when installing. Do not press on the flexible center of filter.
3. Install the cover and secure the strap (Fig. 28).
4. Close the air cleaner access door and the seat.

Servicing the Engine Oil

Change the engine oil and oil filter after the first 50 operating hours and every 100 operating hours thereafter.

Oil Type: Detergent oil (API service SG or higher)

Oil Filter Type: Motorcraft FL-313

Crankcase Capacity: w/filter, 3.5 qts (3.25 l)

Viscosity: Refer to the following table.

USE THESE SAE VISCOSITY OILS

	10W-30									
	5W-20, 5W-30									
°F	-20	0	20	32	40	60	80	100		
°C	-30	-20	-10	0	10	20	30	40		

1. Start the engine and let it run for five minutes. This warms the oil so it drains better.
2. Set the parking brake, stop the pump, stop the engine, and remove the ignition key.
3. Raise the seats.

Caution

Components under the seats will be hot if the sprayer has been running. If you touch hot components you may be burned.

Allow the sprayer to cool before performing maintenance or touching components under the hood.

4. Remove the access plug in the wall behind the engine (Fig. 29).



Figure 29

1. Oil access plug

5. Place a pan below the oil drain.
6. Remove the drain plug (Fig. 30).

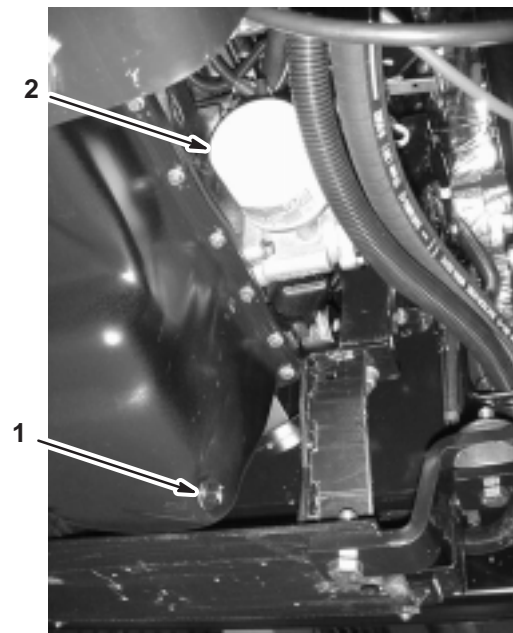

Figure 30

1. Oil drain plug
2. Oil filter

7. When the oil has drained completely, replace the drain plug and torque it to 10 ft-lb (13.6 N·m).
8. Remove the old oil filter (Fig. 30).
9. Wipe the filter adapter gasket surface.
10. Apply a thin coat of new oil to the rubber gasket on the replacement filter.
11. Install the replacement oil filter to the filter adapter. Turn the oil filter clockwise until the rubber gasket contacts the filter adapter, then tighten the filter an additional 1/2 turn (Fig. 30).

Important Do not over tighten the filter.

12. Dispose of the used oil and filter at a certified recycling center.
13. Remove the oil filler cap and slowly pour approximately 80% of the specified amount of oil into the oil filler tube (Fig. 31).

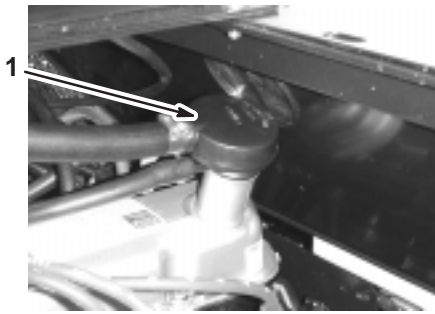

Figure 31

1. Oil filler cap

14. Check the oil level; refer to Checking the Engine Oil Level, page 12.

15. Slowly add additional oil to bring the oil level to the full mark on the dipstick.

Important Overfilling the crankcase with oil may cause engine damage.

16. Replace the oil filler cap and access plug.

Greasing the Sprayer

Lubricate all bearings and bushings after every 50 operating hours or once a year, whichever occurs first.

Grease Type: No. 2 General Purpose Lithium Base Grease

1. Wipe the grease fitting clean so that foreign matter cannot be forced into the bearing or bushing.
2. Pump grease into the bearing or bushing.
3. Wipe off excess grease.

The grease fitting locations are in the positions illustrated in Figures 32 through 35.

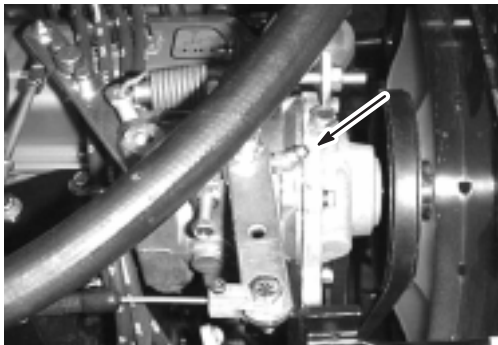

Figure 32

One on the governor lever

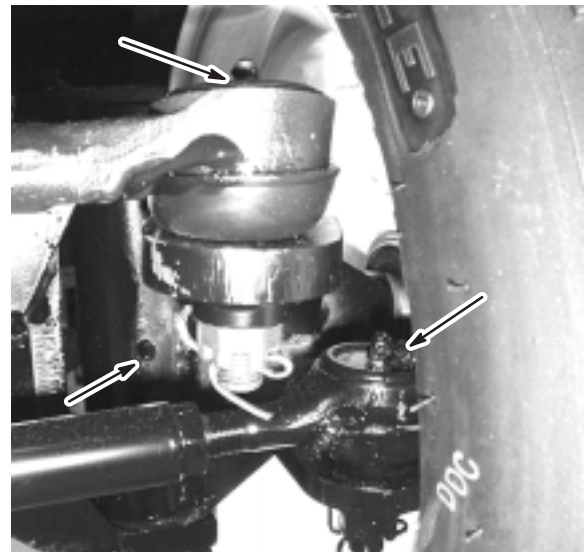

Figure 33

Three inside each front wheel

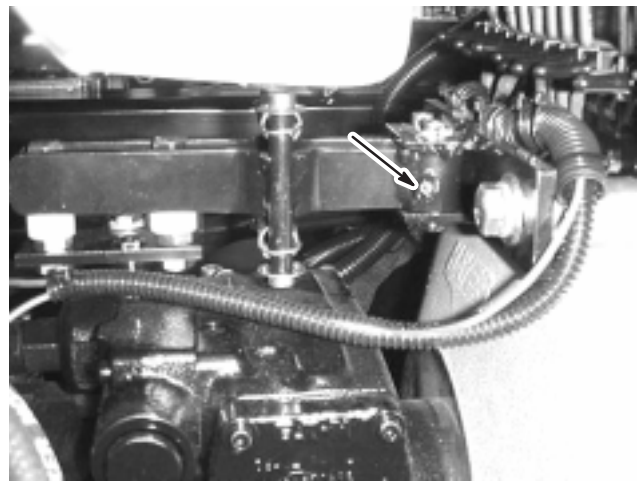

Figure 34

One on each side of the centering arm, between the tank and the engine compartment

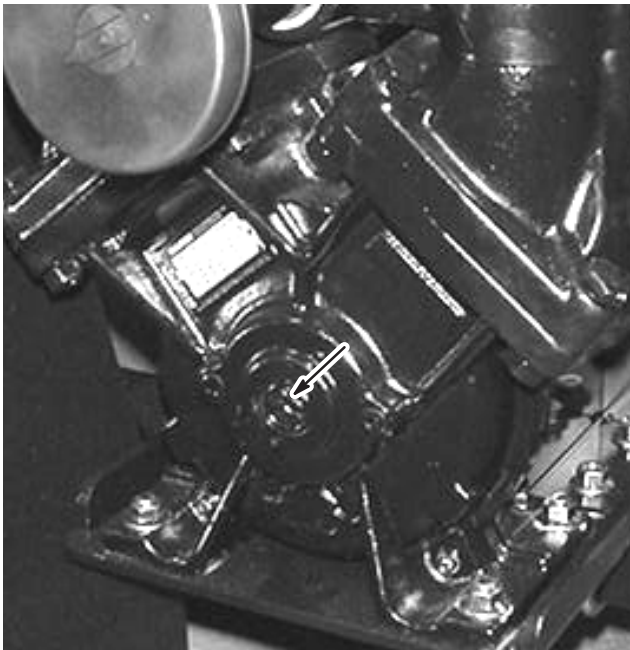

Figure 35

One on the pump

Replacing the Fuel Filters

The sprayer has 2 fuel filters, a threaded filter (located between the fuel pump and the carburetor) and an in-line filter (located between the fuel tank and the fuel pump). Replace the fuel filters after every 400 operating hours.

Replacing the In-line Fuel Filter

1. Set the parking brake, stop the pump, stop the engine, and remove the ignition key.
2. Clamp off the hose on either side of the in-line fuel filter to prevent fuel from pouring out of the hoses when you remove the filter.
3. Place a drain pan under the filter.
4. Loosen and slide the hose clamps away from the filter (Fig. 36).
5. Remove the filter from the fuel lines.

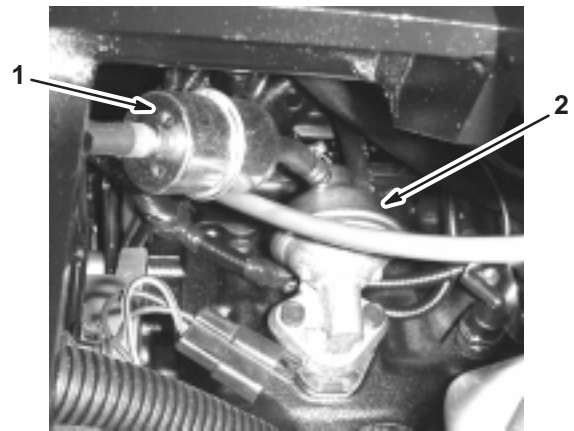

Figure 36

1. In-line fuel filter
2. Threaded fuel filter

6. Install a new filter and move the hose clamps close to the filter.

Ensure that the flow direction arrow points toward the engine.

Replacing the Threaded Fuel Filter

1. Loosen and slide the hose clamp away from the threaded filter (Fig. 36).
2. Remove the hose from the filter (Fig. 36).
3. Using a 5/16 wrench, remove the filter (Fig. 36).
4. Install a new filter and tighten it until it is secure. **Do not** over tighten the filter.
5. Install the hose onto the new filter and secure it with the hose clamp.
6. Start the engine and check the filters for leaks.

Servicing the Cooling System

Clean the radiator fins of all debris using low pressure compressed air, water, or a soft brush every 200 operating hours. Also check all coolant hoses and replace any that are worn, leaking, or damaged.

Important Do not spray water into the engine compartment when the engine is hot.

Important Do not add coolant to an overheated engine until the engine has fully cooled. Adding coolant to an overheated engine may crack the engine block.

Check the engine coolant as directed by the manufacturer every 400 operating hours and change it as needed. Use 12 qt (11.5 l) of a solution of 50% water and 50% permanent ethylene glycol antifreeze.

1. Position the sprayer on a level surface, set the parking brake, stop the pump, stop the engine, and remove the ignition key.



Caution



If the engine has been running, the coolant may be hot and pressurized. If you open the radiator cap when the coolant is hot, it could spray out and severely burn you or bystanders.

Allow the engine to cool for at least 15 minutes before opening the radiator cap. The radiator cap must be cool to the touch.

2. When the engine is cool, remove the radiator cap (Fig. 37).

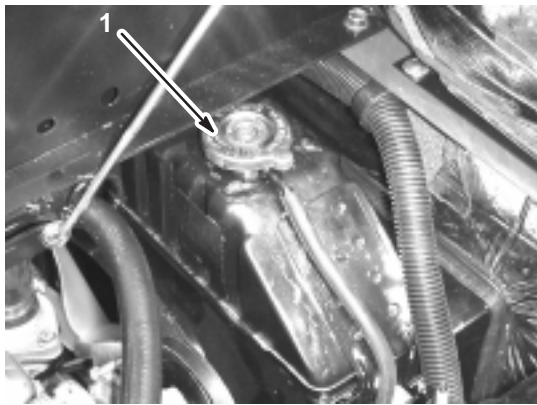

Figure 37

1. Radiator cap

3. Place a large drain pan under the radiator.
4. Open the drain (Fig. 38) and drain the coolant into the pan.

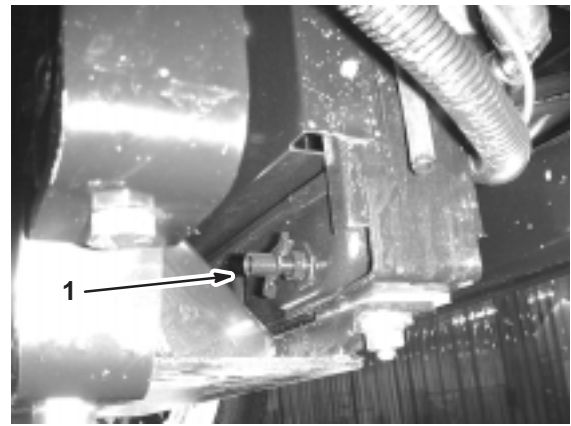

Figure 38

1. Radiator drain
5. Close the drain.
6. Slowly add a solution of 50% water and 50% permanent ethylene glycol antifreeze until the coolant is 3/4 to 1-1/2 inches (2 to 4 cm) below the bottom of the filler neck.
7. Install and secure the radiator cap.

Servicing the Hydraulic Oil

Replace the hydraulic oil filter after the first 8 operating hours and replace the hydraulic oil and filter every 400 hours thereafter.

If the oil becomes contaminated, contact your local Toro distributor because the system must be flushed. Contaminated oil looks milky or black when compared to clean oil.

Replacing the Hydraulic Oil Filter

Use the Toro replacement filter (Part No. 86-3010).

Important Use of any other filter may void the warranty on some components.

1. Position the sprayer on a level surface, set the parking brake, stop the pump, stop the engine, and remove the ignition key.
2. Clean the area around the filter mounting area (Fig. 39).

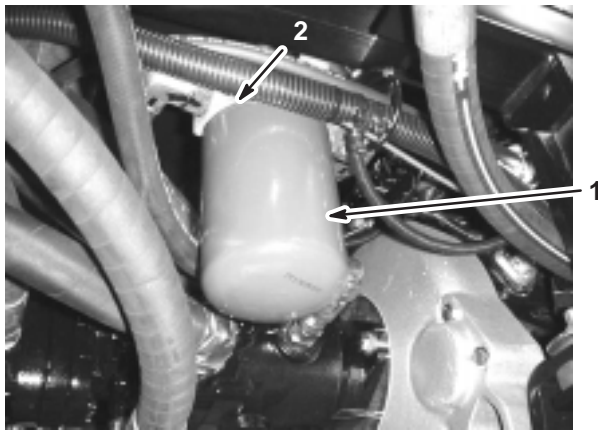

Figure 39

1. Hydraulic filter
2. Gasket

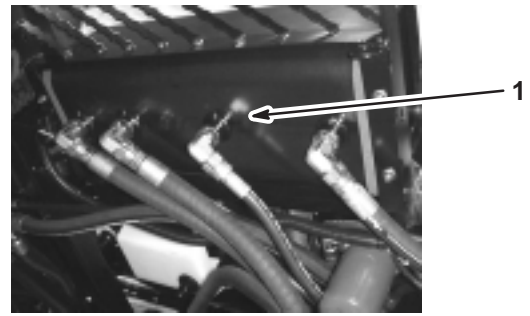

Figure 40

1. Hydraulic hose and fitting

3. Place a drain pan under the filter.
4. Remove the filter (Fig. 39).
5. Lubricate the new filter gasket (Fig. 39).
6. Ensure that the filter mounting area is clean.
7. Screw the filter on until the gasket contacts the mounting plate, then tighten the filter 1/2 turn.
8. Start the engine and let it run for about 2 minutes to purge air from the system.
9. Stop the engine and check the hydraulic oil level and for leaks.
10. Dispose of the used filter at a certified recycling center.

Changing the Hydraulic Oil

Use 12 US gallons (45.4 l) of Mobil 424 hydraulic oil or equivalent.

1. Replace the hydraulic oil filter; refer to Replacing the Hydraulic Oil Filter, page 30.
2. Clean the area around one hydraulic hose fitting on the bottom of the hydraulic oil tank (Fig. 40).

3. Place a large pan under the fitting.
4. Remove the hose fitting from the tank, allowing the oil to drain into the pan (Fig. 40).
5. Install the hose and fitting to the tank and tighten it securely.
6. Fill the hydraulic reservoir with approximately 12 US gallons (45.4 l) of Mobil 424 hydraulic oil or equivalent.
7. Start the machine and run it at idle for 3 to 5 minutes to circulate the fluid and remove any air trapped in the system.
8. Stop the engine and check the hydraulic oil level and for leaks.
9. Dispose of the used oil at a certified recycling center.

Checking the Hydraulic Lines and Hoses

Inspect the hydraulic lines and hoses daily for leaks, kinked lines, loose mounting supports, wear, loose fittings, weather deterioration and chemical deterioration. Make all necessary repairs before operating.



Warning



Hydraulic fluid escaping under pressure can penetrate skin and cause injury.

- Make sure all hydraulic fluid hoses and lines are in good condition and all hydraulic connections and fittings are tight before applying pressure to the hydraulic system.
- Keep your body and hands away from pin hole leaks or nozzles that eject high pressure hydraulic fluid.
- Use cardboard or paper to find hydraulic leaks.
- Safely relieve all pressure in the hydraulic system before performing any work on the hydraulic system.
- Get immediate medical help if fluid is injected into skin.

Changing the Planetary Gearbox Fluid

Change the planetary gearbox in each rear wheel after the first 8 hours and then after every 400 hours thereafter.

Use high quality, SAE 85W-140 weight gear lube.

1. Position the sprayer on a level surface with the rear wheels positioned for draining as illustrated in Figure 41.

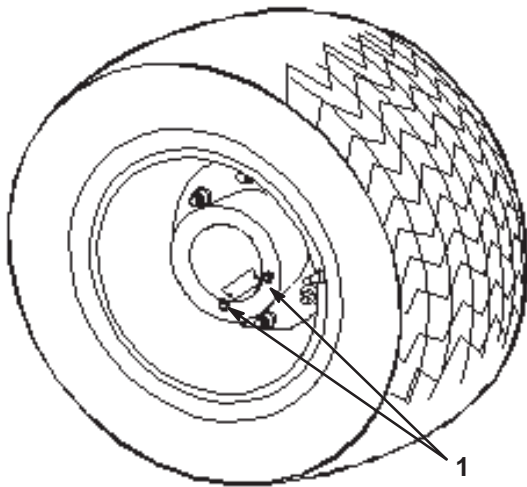

Figure 41

1. Drain plugs, positioned for draining
-
2. Set the parking brake, stop the pump, stop the engine, and remove the ignition key.

3. Place a pan under the drain plugs and remove them from the wheel (Fig. 41).
4. Place a pan under the inner drain plug and remove it (Fig. 42).

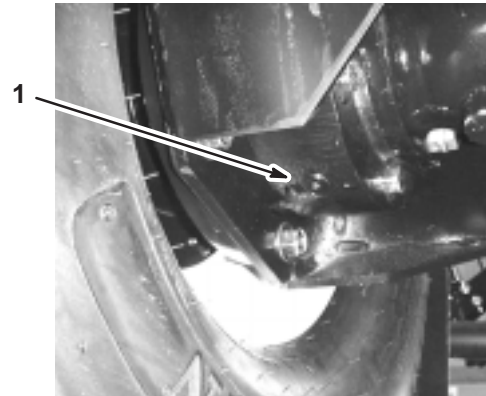

Figure 42

1. Inner drain plug
-

5. When all fluid has drained, replace the inner drain plug.
6. Move the vehicle slowly until the wheel is positioned for filling as illustrated in Figure 43.

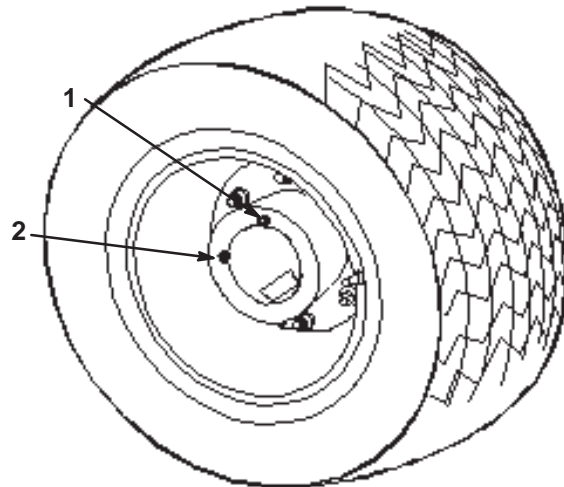

Figure 43

1. Upper hole, add fluid here
 2. Lower hole
-

7. Set the parking brake, stop the pump, stop the engine, and remove the ignition key.
8. Pour SAE 85W-140 weight gear lube into the upper hole until it begins to come out of the lower hole.
9. Replace and tighten all drain plugs.
10. Repeat steps 1 through 9 for the other rear wheel.

11. Dispose of the used oil at a certified recycling center.

Adjusting the Brakes

Check the brake adjustment daily. If the brake pedal travels more than 1 inch (2.54 cm) before you feel resistance, adjust the brakes as follows.

1. Position the sprayer on a level surface, stop the pump, stop the engine, and remove the ignition key.
2. Release the parking brake if it is set.
3. Loosen the front nuts on the brake cables under the front end of the sprayer (Fig. 44).

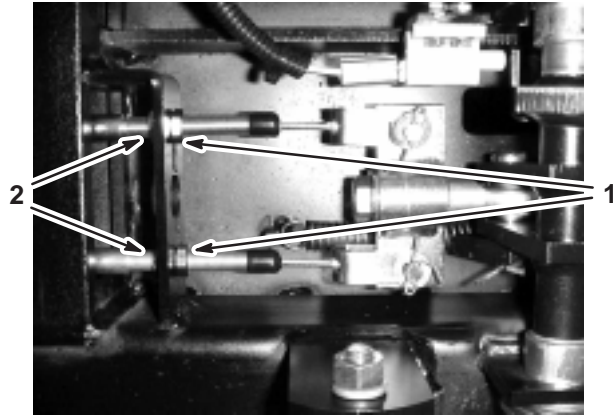

Figure 44

1. Front nuts
2. Rear nuts

4. Tighten the rear nuts equally until the brake pedal moves between 1/2 to 1 inch (1 to 2 cm) before resistance is felt (Fig. 44).

Important Ensure that you tighten both rear nuts equally so that the threaded ends of the brake cables in front of the front nuts are the same length.

5. Tighten the front nuts.

Adjusting the Throttle Lever Tension

If the throttle lever begins to creep away from the Fast position during operation, tighten the throttle pivot lock nut as follows:

1. Position the sprayer on a level surface, set the parking brake, stop the pump, stop the engine, and remove the ignition key.
2. Remove the throttle lever knob.
3. Release the latch and remove the spray console cover and switches.
4. Tighten the throttle pivot lock nut (Fig. 45)

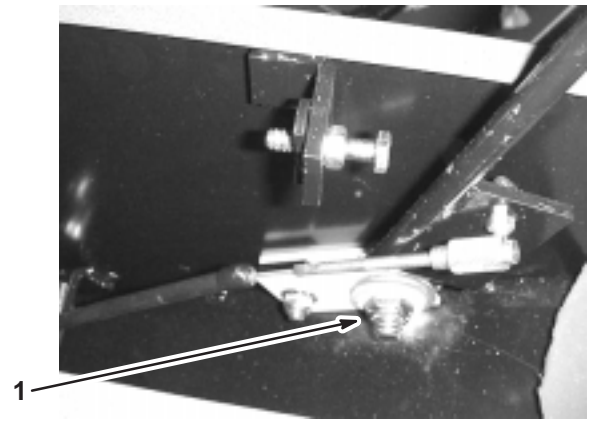

Figure 45

1. Throttle pivot lock nut

5. Replace and secure the spray consol cover and the throttle lever knob.
6. Move the throttle lever to the Slow position.

Adjusting the Front Wheel Toe-In

Check the front wheel toe-in after every 200 operating hours, or annually, whichever occurs first. The toe-in should be 1/8 to 1/4 inch (0 to 6 mm).

1. Check and fill all tires; refer to Checking Tire Pressure, page 13.
2. Measure the distance between both of the front tires at the axle height at both the front and rear of the front tires (Fig. 46).

The front of the tires should be 1/8 to 1/4 inch (3 to 6 mm) less than the back side of the front tires.

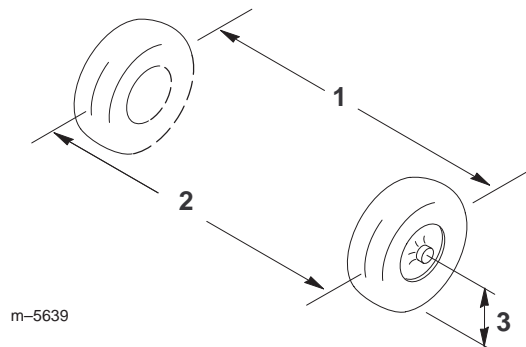

Figure 46

1. Tire center line—back
2. Tire center line—front
3. Axle center height

3. If the measurement does not fall within the specified range, loosen the jam nuts at both ends of the tie rod (Fig. 47).

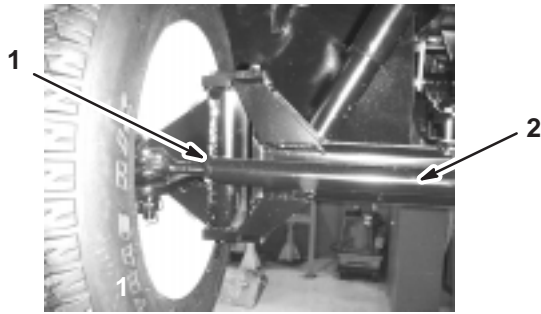

Figure 47

1. Jam nut

2. Tie rod

4. Rotate the tie rod to move the front of the tire inward or outward.
5. Tighten the tie rod jam nuts when the adjustment is correct.
6. Ensure that there is full travel of the steering wheel in both directions.

Servicing the Drive Belts

Checking the Drive Belts

Check the condition and tension of the drive belts after the first 8 operating hours and every 100 operating hours thereafter.

Use a belt tension tool, according to manufacturer directions to check the tension. The tension should be as follows:

- Alternator belt (Fig. 48)
 - New belt—79 to 101 lb (351 to 449 N)
 - Used belt (run more than 10 minutes)—56 to 75 lb (249 to 333 N)
- Governor/cooling fan belt (Fig.)
 - New belt—75 lb (333 N)
 - Used belt (run more than 10 minutes)—50 lb (222 N)

Adjusting/Replacing the Alternator Belt

1. Position the sprayer on a level surface, set the parking brake, stop the pump, stop the engine, and remove the ignition key.
2. Loosen the alternator mounting bolts (Fig. 48).

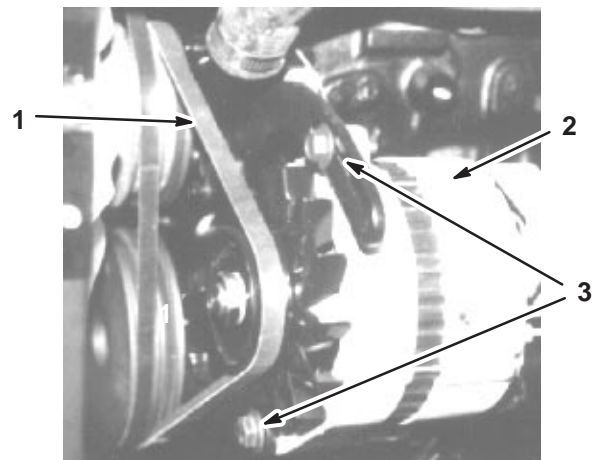

Figure 48

1. Alternator belt

2. Alternator

3. Mounting bolts

3. If the belt is worn or damaged, remove it and replace it with a new belt.
4. Insert a pry bar between the alternator and the engine and pull the alternator out until you achieve the desired tension.
5. Hold the alternator in place and tighten the mounting bolts.

Adjusting/Replacing the Governor/Cooling Fan Belt

1. Position the sprayer on a level surface, set the parking brake, stop the pump, stop the engine, and remove the ignition key.
2. Loosen the 3 governor mounting bolts (Fig. 49).

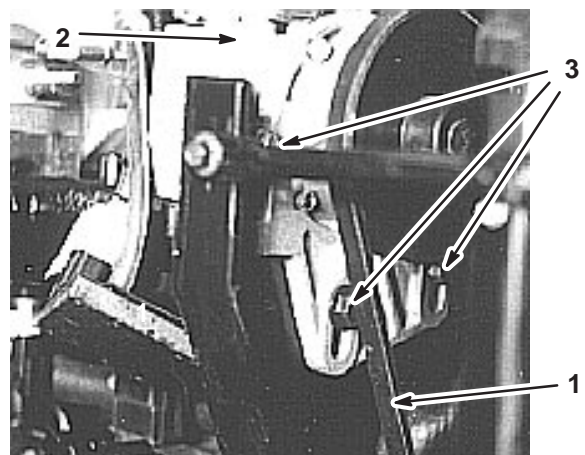

Figure 49

1. Governor/cooling fan belt

2. Governor

3. Mounting bolts

3. If the belt is worn or damaged, remove it and replace it with a new belt.

Note: To replace the governor/cooling fan belt, you will need to remove the alternator belt; refer to adjusting/Replacing the Alternator Belt, page 34.

4. Pull the governor up until you achieve the desired tension.
5. Hold the governor in place and tighten the mounting bolts.

Changing the Spark Plugs

Change the spark plugs after every 400 operating hours. Make sure the air gap between the center and side electrodes is correct before installing the spark plugs. Use a spark plug wrench for removing and installing the spark plugs and a gapping tool/feeler gauge to check and adjust the air gap.

Type: Motorcraft-AGSF 22C or AGRF22

Air Gap: 0.040 inch (1 mm)

Removing the Spark Plugs

1. Set the parking brake, stop the pump, stop the engine, and remove the ignition key.
2. Lift the driver seat.
3. Grasp the molded wire boot of a spark plug wire, twist it, and pull it from the spark plug; repeat for the other spark plug wires (Fig. 50).

Important Do not grab the wires and pull. Only remove the wires by grasping the molded boots.

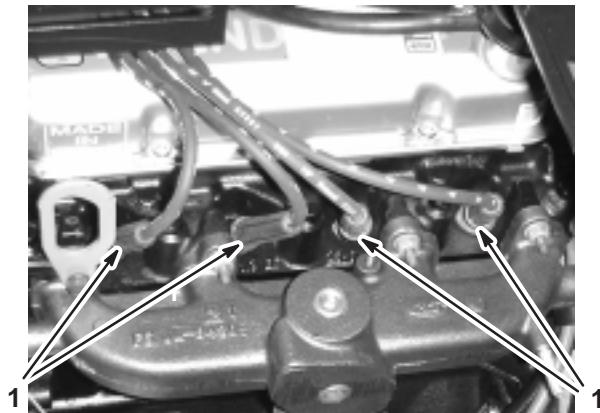

Figure 50

1. Spark plug wire

4. Clean around the spark plugs to prevent dirt from falling into the engine and potentially causing damage.
5. Remove the spark plugs and metal washers.

Checking the Spark Plugs

1. Look at the center of the spark plugs (Fig. 51).

If you see a light brown or gray coating on the insulator, the engine is operating properly. A black coating on the insulator usually means the air cleaner is dirty.

Important Do not clean the spark plugs. Always replace a spark plug when it has a black coating, worn electrodes, an oily film, or cracks.

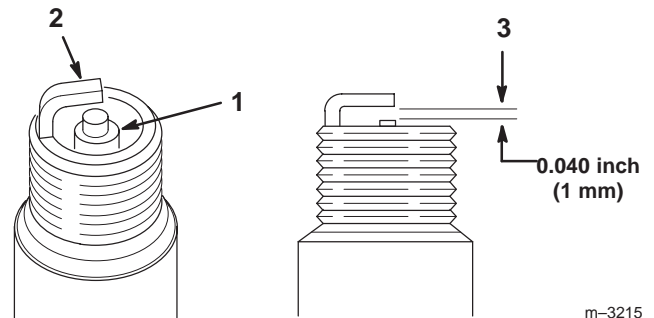

Figure 51

1. Center electrode insulator
 2. Side electrode
 3. Air gap (not to scale)
-
2. Check the gap between the center and side electrodes (Fig. 51) and bend the side electrode, if the gap is not correct.

Installing the Spark Plugs

1. Install the spark plugs and metal washers.
2. Tighten the spark plugs to 18 to 22 ft-lb (24.4 to 29.8 N·m).
3. Push the wires onto the spark plugs (Fig. 50).
4. Lower the seat.

Replacing the Fuses

There are 4 fuses and 4 empty slots in the electrical system. They are located beneath the driver seat (Fig. 52).

Main electrical system	20 amp
Speed control	5 amp
Headlights	10 amp
Spray system	10 amp

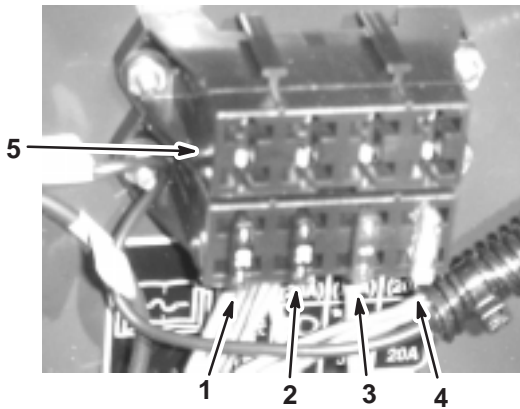

Figure 52

1. Spray system
2. Headlights
3. Speed control
4. Main electrical system
5. 4 open positions

Servicing the Battery

! **Warning** !

CALIFORNIA
Proposition 65 Warning

Battery posts, terminals, and related accessories contain lead and lead compounds, chemicals known to the State of California to cause cancer and reproductive harm. Wash hands after handling.

Always keep the battery clean and fully charged. Use a paper towel to clean the battery and battery box. If the battery terminals are corroded, clean them with a solution of four parts water and one part baking soda. Apply a light coating of grease to the battery terminals to prevent corrosion.

Voltage: 12 volt with 460 cold cranking Amps @ 0° F (-18° C)

Removing the Battery

1. Position the sprayer on a level surface, set the parking brake, stop the pump, stop the engine, and remove the ignition key.
2. Remove the battery retainer and fasteners (Fig. 53).

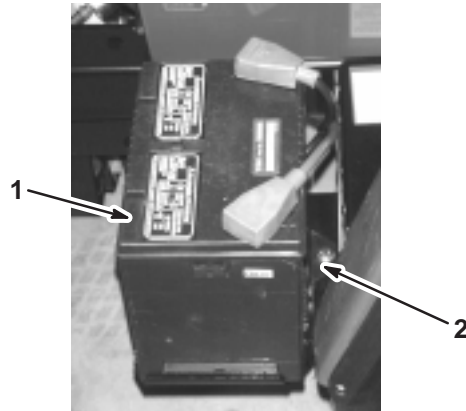

Figure 53

1. Battery
2. Battery retainer

3. Disconnect the negative (black) ground cable from the battery post.

! **Warning** !

Incorrect battery cable routing could damage the sprayer and cables causing sparks. Sparks can cause the battery gasses to explode, resulting in personal injury.

- Always *disconnect* the negative (black) battery cable before disconnecting the positive (red) cable.
- Always *reconnect* the positive (red) battery cable before reconnecting the negative (black) cable.

! **Warning** !

Battery terminals or metal tools could short against metal sprayer components causing sparks. Sparks can cause the battery gasses to explode, resulting in personal injury.

- When removing or installing the battery, do not allow the battery terminals to touch any metal parts of the sprayer.
- Do not allow metal tools to short between the battery terminals and metal parts of the sprayer.
- Always keep the battery strap in place to protect and secure the battery.

4. Disconnect the positive (red) cable from the battery post.
5. Remove the battery.

Installing the Battery



1. Set the battery on the battery box so that the battery posts are toward the front of the sprayer.
2. Connect the positive (red) cable to the positive (+) battery post and the negative (black) cable to the negative (-) battery post using the bolts and wing nuts. Slide the rubber boot over the positive battery post.
3. Install the battery retainer and secure it with the fasteners you removed previously (Fig. 53).

Important Always keep the battery retainer in place to protect and secure the battery.

Checking the Electrolyte Level

Check the electrolyte level every 50 operating hours or, if the machine is in storage, every 30 days.

Remove the filler caps. If the electrolyte is not up to the fill line, add the required amount of distilled water; refer to Adding Water to the Battery, page 37.

 **Danger** 

Battery electrolyte contains sulfuric acid which is a deadly poison and causes severe burns.

- **Do not drink electrolyte and avoid contact with skin, eyes or clothing. Wear safety glasses to shield your eyes and rubber gloves to protect your hands.**
- **Fill the battery where clean water is always available for flushing the skin.**

Adding Water to the Battery

The best time to add distilled water to the battery is just before you operate the machine. This lets the water mix thoroughly with the electrolyte solution.



1. Clean the top of the battery with a paper towel.
2. Remove the filler caps from the battery and slowly fill each cell with distilled water until the level is up to the fill line. Replace the filler caps.

Important Do not overfill the battery. Electrolyte will overflow onto other parts of the sprayer and severe corrosion and deterioration will result.

Charging the Battery

Important Always keep the battery fully charged (1.260 specific gravity). This is especially important to prevent battery damage when the temperature is below 32° F (0° C).

1. Remove the battery from the chassis; refer to Removing the Battery, page 36.
2. Check the electrolyte level; refer to Checking the Electrolyte Level, page 37.
3. Connect a 3 to 4 amp battery charger to the battery posts. Charge the battery at a rate of 3 to 4 amperes for 4 to 8 hours (12 volts). Do not overcharge the battery.

 **Warning** 

Charging the battery produces gasses that can explode.

Never smoke near the battery and keep sparks and flames away from battery.

4. Install the battery in the chassis; refer to Installing the Battery, page 37.

Storing the Battery

If the machine will be stored for more than 30 days, remove the battery and charge it fully. Either store it on the shelf or on the machine. Leave the cables disconnected if it is stored on the machine. Store the battery in a cool atmosphere to avoid quick deterioration of the charge in the battery. To prevent the battery from freezing, make sure it is fully charged.

Cleaning the Suction Strainer

Clean the suction strainer daily. If you are using wettable powders, clean it after every tank.

1. Position the sprayer on a level surface, set the parking brake, stop the pump, stop the engine, and remove the ignition key.
2. Remove the retainer from the red fitting attached to the large hose on the top of the tank (Fig. 54).



Figure 54

1. Suction hose
2. Retainer

3. Disconnect the hose from the tank (Fig. 54).
4. Pull the strainer out of the hole (Fig. 55).

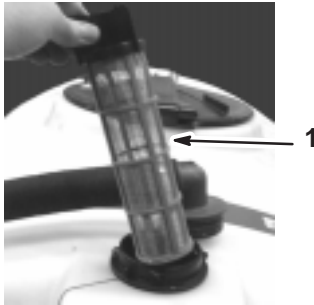

Figure 55

1. Suction strainer
5. Clean the strainer with clean running water.
 6. Replace the strainer, seating it fully into the hole.
 7. Connect the hose to the top of the tank and secure it with the retainer.

Storage

1. Position the sprayer on a level surface, set the parking brake, stop the pump, stop the engine, and remove the ignition key.
2. Clean dirt and grime from the entire machine, including the outside of the engine's cylinder head fins and blower housing.

Important You can wash the machine with mild detergent and water. **Do not use high pressure water** to wash the machine. Pressure washing may damage the electrical system or wash away necessary grease at friction points. Avoid excessive use of water, especially near the control panel, lights, engine, and the battery.

3. Clean the spray system; refer to Cleaning the Sprayer, page 22.
4. Add a rust inhibiting, non-alcohol based, RV antifreeze solution to the system and run the pump for a few minutes to circulate it through the system, then drain the spray system as completely as possible.
5. Check the brakes; refer to Checking the Brakes, page 14.
6. Service the air cleaner; refer to Servicing the Air Cleaner, page 25.
7. Grease the sprayer; refer to Greasing the Sprayer, page 28.
8. Change the engine oil; refer to Servicing Engine Oil, page 26.
9. Check the tire pressure; refer to Checking the Tire Pressure, page 13.
10. For storage over 30 days, prepare the fuel system as follows:
 - A. Add a petroleum based stabilizer/conditioner to fuel in the tank.

Follow mixing instructions from stabilizer manufacturer. (1 oz. per gallon). **Do not use an alcohol based stabilizer (ethanol or methanol).**

Note: A fuel stabilizer/conditioner is most effective when mixed with fresh gasoline and used at all times.
 - B. Run the engine to distribute conditioned fuel through the fuel system (5 minutes).
 - C. Stop the engine, allow it to cool, and drain the fuel tank.
 - D. Restart the engine and run it until it stops.
 - E. Choke the engine.
 - F. Start and run the engine until it will not start again.
 - G. Dispose of fuel properly. Recycle as per local codes.

Important Do not store stabilizer/conditioned gasoline over 90 days.

11. Remove the spark plugs and check their condition; refer to Changing Spark Plugs, page 35.
12. With the spark plugs removed from the engine, pour two tablespoons of engine oil into the spark plug hole.
13. Use the electric starter to crank the engine and distribute the oil inside the cylinder.
14. Install the spark plugs and tighten to recommended torque; refer to Changing Spark Plugs, page 35.

Note: Do not install the wire on the spark plug(s).

15. Remove the battery from the chassis, check the electrolyte level, and charge it fully; refer to Servicing the Battery, page 36.

Note: Do not connect the battery cables to the battery posts during storage.

Important The battery must be fully charged to prevent it from freezing and being damaged at temperatures below 32°F (0°C). A fully charged battery maintains its charge for about 50 days at temperatures lower than 40°F (4°C). If the temperatures will be above 40°F (4°C), check the water level in the battery and charge it every 30 days.

16. Check and tighten all bolts, nuts, and screws. Repair or replace any part that is damaged.
17. Check the condition of all spray hoses, replacing any that are damaged or worn.
18. Tighten all hose fittings.
19. Paint all scratched or bare metal surfaces.
Paint is available from your Authorized Service Dealer.
20. Store the machine in a clean, dry garage or storage area.
21. Remove the ignition key and put it in a safe place out of the reach of children.
22. Cover the machine to protect it and keep it clean.

Troubleshooting

Troubleshooting the Engine and Vehicle

Problem	Possible Causes	Corrective Action
The starter does not crank.	<ol style="list-style-type: none"> 1. The traction pedal is not in Neutral. 2. The electrical connections are corroded or loose. 3. A fuse is blown or loose. 4. The battery is discharged. 5. The safety interlock system is malfunctioning. 6. A broken starter or starter solenoid. 7. Seized internal engine components. 	<ol style="list-style-type: none"> 1. Release the traction pedal. 2. Check the electrical connections for good contact. 3. Correct or replace fuse. 4. Charge or replace the battery. 5. Contact your Authorized Service Dealer. 6. Contact your Authorized Service Dealer. 7. Contact your Authorized Service Dealer.
The engine cranks, but will not start.	<ol style="list-style-type: none"> 1. The fuel tank is empty. 2. Dirt, water, or stale fuel is in the fuel system. 3. Clogged fuel line. 4. A spark plug lead is disconnected. 5. A spark plug is damaged or dirty. 6. The kill relay is not energized. 7. The ignition is broken. 	<ol style="list-style-type: none"> 1. Fill with fresh fuel. 2. Drain and flush the fuel system; add fresh fuel. 3. Clean or replace. 4. Reconnect the spark plug. 5. Replace the spark plug. 6. Contact your Authorized Service Dealer. 7. Contact your Authorized Service Dealer.
The engine starts, but does not keep running	<ol style="list-style-type: none"> 1. The fuel tank vent is restricted. 2. Dirt or water in the fuel system. 3. The fuel filter is clogged. 4. A fuse is blown or loose. 5. The fuel pump is broken. 6. The carburetor is broken. 7. Loose wires or poor connections. 8. The cylinder head gasket is broken. 	<ol style="list-style-type: none"> 8. Replace the fuel cap. 9. Drain and flush the fuel system; add fresh fuel. 10. Replace the fuel filter. 11. Correct or replace fuse. 12. Contact your Authorized Service Dealer. 13. Contact your Authorized Service Dealer. 14. Check and tighten wire connections. 15. Contact your Authorized Service Dealer.

Problem	Possible Causes	Corrective Action
The engine runs, but knocks or misses.	<ol style="list-style-type: none"> 1. Dirt, water, or stale fuel is in the fuel system. 2. A spark plug lead is loose. 3. A spark plug is broken. 4. Loose wires or poor connections. 5. The engine is overheated. 	<ol style="list-style-type: none"> 1. Drain and flush the fuel system; add fresh fuel. 2. Reconnect the spark plug lead. 3. Replace the spark plug. 4. Check and tighten wire connections. 5. See Engine Overheats.
The engine will not idle.	<ol style="list-style-type: none"> 1. The fuel tank vent is restricted. 2. Dirt, water, or stale fuel is in the fuel system. 3. A spark plug is damaged or broken. 4. Carburetor idle passages are plugged. 5. The idle speed adjusting screw is incorrectly set. 6. The fuel pump is broken. 7. Low compression. 8. The air cleaner element is dirty. 	<ol style="list-style-type: none"> 1. Replace the fuel cap. 2. Drain and flush the fuel system; add fresh fuel. 3. Replace the spark plug. 4. Contact your Authorized Service Dealer. 5. Contact your Authorized Service Dealer. 6. Contact your Authorized Service Dealer. 7. Contact your Authorized Service Dealer. 8. Clean or replace.
The engine overheats.	<ol style="list-style-type: none"> 1. The crankcase oil level is incorrect. 2. Excessive loading. 3. The radiator is dirty. 4. The coolant is low. 5. The fuel mixture is lean. 	<ol style="list-style-type: none"> 1. Fill or drain to the full mark. 2. Reduce load; use lower ground speed. 3. Clean with every use. 4. Add coolant. 5. Contact your Authorized Service Dealer.
The engine loses power.	<ol style="list-style-type: none"> 1. The crankcase oil level is incorrect. 2. The air cleaner element is dirty. 3. Dirt, water, or stale fuel is in the fuel system. 4. The engine is overheated. 5. A spark plug is damaged or dirty. 6. The vent hole in the fuel tank vent fitting is plugged. 7. Low compression. 	<ol style="list-style-type: none"> 1. Fill or drain to the full mark. 2. Clean or replace. 3. Drain and flush the fuel system; add fresh fuel. 4. See Engine Overheats. 5. Replace the spark plug. 6. Replace the fuel cap. 7. Contact your Authorized Service Dealer.

Problem	Possible Causes	Corrective Action
The sprayer will not operate or is sluggish in either direction because the engine bogs down or stalls.	1. The parking brake is set.	1. Release the parking brake
The sprayer will not operate in either direction.	1. The parking brake was not released or the parking brake is not releasing. 2. The transmission is broken. 3. The control linkage needs adjustment or replacement. 4. The drive shaft or wheel hub key has been damaged.	1. Release the parking brake or check the linkage. 2. Contact your Authorized Service Dealer. 3. Contact your Authorized Service Dealer. 4. Contact your Authorized Service Dealer.
Abnormal vibration or noise.	1. The engine mounting bolts are loose.	1. Tighten the engine mounting bolts.

Troubleshooting the Spray System

Problem	Possible Causes	Corrective Action
A boom section does not spray.	1. The electrical connection on the boom valve is dirty or disconnected 2. Blown fuse 3. Pinched hose 4. A boom by-pass valve is improperly adjusted. 5. Damaged boom valve 6. Damaged electrical system	1. Turn the valve off manually. Disconnect the electrical connector on the valve and clean all leads, then reconnect it. 2. Check the fuses and replace them as necessary. 3. Repair or replace the hose. 4. Adjust the boom by-pass valves. 5. Contact your Authorized Service Dealer. 6. Contact your Authorized Service Dealer.
A boom section does not turn off.	1. The valve is damaged.	1. Stop the spray system and pump and turn off the sprayer. Remove the retainer from under the boom valve and pull out the motor and stem. Inspect all parts and replace any that appear damaged.
A boom valve is leaking	1. An O-ring is deteriorated.	1. Stop the spray system and pump and turn off the sprayer. Disassemble the valve and replace the O-rings.

Problem	Possible Causes	Corrective Action
A pressure drop occurs when you turn on a boom.	<ol style="list-style-type: none"> 1. The boom bypass valve is improperly adjusted. 2. There is an obstruction in the boom valve body. 	<ol style="list-style-type: none"> 1. Adjust the boom bypass valve. 2. Remove the inlet and outlet connections to the boom valve and remove any obstructions.
A pressure increase occurs when you turn on a boom.	<ol style="list-style-type: none"> 1. A nozzle filter is clogged. 	<ol style="list-style-type: none"> 1. Remove and clean all nozzles.



The Toro General Commercial Products Warranty

A Two-Year Limited Warranty

Conditions and Products Covered

The Toro Company and its affiliate, Toro Warranty Company, pursuant to an agreement between them, jointly warrant your 1996 or newer Toro Commercial Product ("Product") purchased after January 1, 1997, to be free from defects in materials or workmanship for two years or 1500 operational hours*, whichever occurs first. Where a warrantable condition exists, we will repair the Product at no cost to you including diagnosis, labor, parts, and transportation. This warranty begins on the date the Product is delivered to the original retail purchaser.

* Product equipped with hour meter

Instructions for Obtaining Warranty Service

You are responsible for notifying the Commercial Products Distributor or Authorized Commercial Products Dealer from whom you purchased the Product as soon as you believe a warrantable condition exists.

If you need help locating a Commercial Products Distributor or Authorized Dealer, or if you have questions regarding your warranty rights or responsibilities, you may contact us at:

Toro Commercial Products Service Department
Toro Warranty Company
8111 Lyndale Avenue South
Bloomington, MN 55420-1196
952-888-8801 or 800-982-2740
E-mail: commercial.service@toro.com

Owner Responsibilities

As the Product owner, you are responsible for required maintenance and adjustments stated in your operator's manual. Failure to perform required maintenance and adjustments can be grounds for disallowing a warranty claim.

Items and Conditions Not Covered

Not all product failures or malfunctions that occur during the warranty period are defects in materials or workmanship. This express warranty does not cover the following:

- Product failures which result from the use of non-Toro replacement parts, or from installation and use of add-on, modified, or unapproved accessories
- Product failures which result from failure to perform required maintenance and/or adjustments
- Product failures which result from operating the Product in an abusive, negligent or reckless manner
- Parts subject to consumption through use unless found to be defective. Examples of parts which are consumed, or used up, during normal Product operation include, but are not limited to, blades, reels, bedknives, tines, spark plugs, castor wheels, tires, filters, belts, etc.

Countries Other than the United States or Canada

Customers who have purchased Toro products exported from the United States or Canada should contact their Toro Distributor (Dealer) to obtain guarantee policies for your country, province, or state. If for any reason you are dissatisfied with your Distributor's service or have difficulty obtaining guarantee information, contact the Toro importer. If all other remedies fail, you may contact us at Toro Warranty Company.

- Failures caused by outside influence. Items considered to be outside influence include, but are not limited to, weather, storage practices, contamination, use of unapproved coolants, lubricants, additives, or chemicals, etc.
- Normal "wear and tear" items. Normal "wear and tear" includes, but is not limited to, damage to seats due to wear or abrasion, worn painted surfaces, scratched decals or windows, etc.

Parts

Parts scheduled for replacement as required maintenance are warranted for the period of time up to the scheduled replacement time for that part.

Parts replaced under this warranty become the property of Toro. Toro will make the final decision whether to repair any existing part or assembly or replace it. Toro may use factory remanufactured parts rather than new parts for some warranty repairs.

General Conditions

Repair by an Authorized Toro Distributor or Dealer is your sole remedy under this warranty.

Neither The Toro Company nor Toro Warranty Company is liable for indirect, incidental or consequential damages in connection with the use of the Toro Products covered by this warranty, including any cost or expense of providing substitute equipment or service during reasonable periods of malfunction or non-use pending completion of repairs under this warranty. Except for the Emissions warranty referenced below, if applicable, there is no other express warranty. All implied warranties of merchantability and fitness for use are limited to the duration of this express warranty.

Some states do not allow exclusions of incidental or consequential damages, or limitations on how long an implied warranty lasts, so the above exclusions and limitations may not apply to you.

This warranty gives you specific legal rights, and you may also have other rights which vary from state to state.

Note regarding engine warranty: The Emissions Control System on your Product may be covered by a separate warranty meeting requirements established by the U.S. Environmental Protection Agency (EPA) and/or the California Air Resources Board (CARB). The hour limitations set forth above do not apply to the Emissions Control System Warranty. Refer to the Engine Emission Control Warranty Statement printed in your operator's manual or contained in the engine manufacturer's documentation for details.