



Count on it.

Parts Catalog

GrandStand® Mower

With 48in TURBO FORCE® Cutting Unit

Model No. 72504—Serial No. 415400000 and Up



Ordering Replacement Parts

To order replacement parts, please supply the part number, the quantity, and the description of each part desired.

Understanding Reference Numbers

Each identified part in an illustration has a reference number. The reference number for a part also appears in the parts list, along with other information about the part.

This catalog uses two special reference number formats, one to indicate parts in a service assembly and another to indicate the quantity of a given part in an illustration.

Service Assembly Reference Numbers

Parts in service assemblies have reference numbers in the form a:b. The a represents the reference number of the entire service assembly and the b represents a sequential number unique to each part within the service assembly.

For example, a wheel assembly might be identified by reference number 6, the tire by 6:1, the valve by 6:2, and the wheel by 6:3. When you order the assembly identified by reference number 6, you receive all parts identified by reference numbers 6:1, 6:2, and 6:3. However, you may also order any part individually. Reference numbers of this type appear in illustration and in parts lists.

Reference Numbers Indicating Quantity

In an illustration, if a reference number indicates more than one part, the reference number has the form nX y. The n represents the quantity of the part, the X is the multiplication symbol, and the y represents the reference number.

For example, in an illustration, the reference number 2X 37 means that two of the parts identified by reference number 37 are indicated.

Contents

48 Inch Deck Assembly	4
Deck Decal Assembly No. 139-8093	6
Spindle Assembly No. 137-9780	8
Deflector Assembly No. 120-2451	10
Ground Drive Assembly	12
LH Transmission Assembly No. 138-5838	14
RH Transmission Assembly No. 138-5839	16
Overflow Hose Assembly	18
Motion Control Assembly	20
Control Handle Assembly No. 132-5157	22
Control Handle Assembly No. 132-5158	24
Parking Brake Assembly	26
Deck Lift Assembly	28
HOC Lever Assembly No. 161-6735	30
HOC Link Assembly No. 130-6615	32
Frame Assembly	34
Wheel and Bearing Assembly	36
Platform Assembly	38
Engine Assembly	40
Fuel Tank Assembly	42
Electrical Assembly	44
Attachments and Accessories	46

48 Inch Deck Assembly

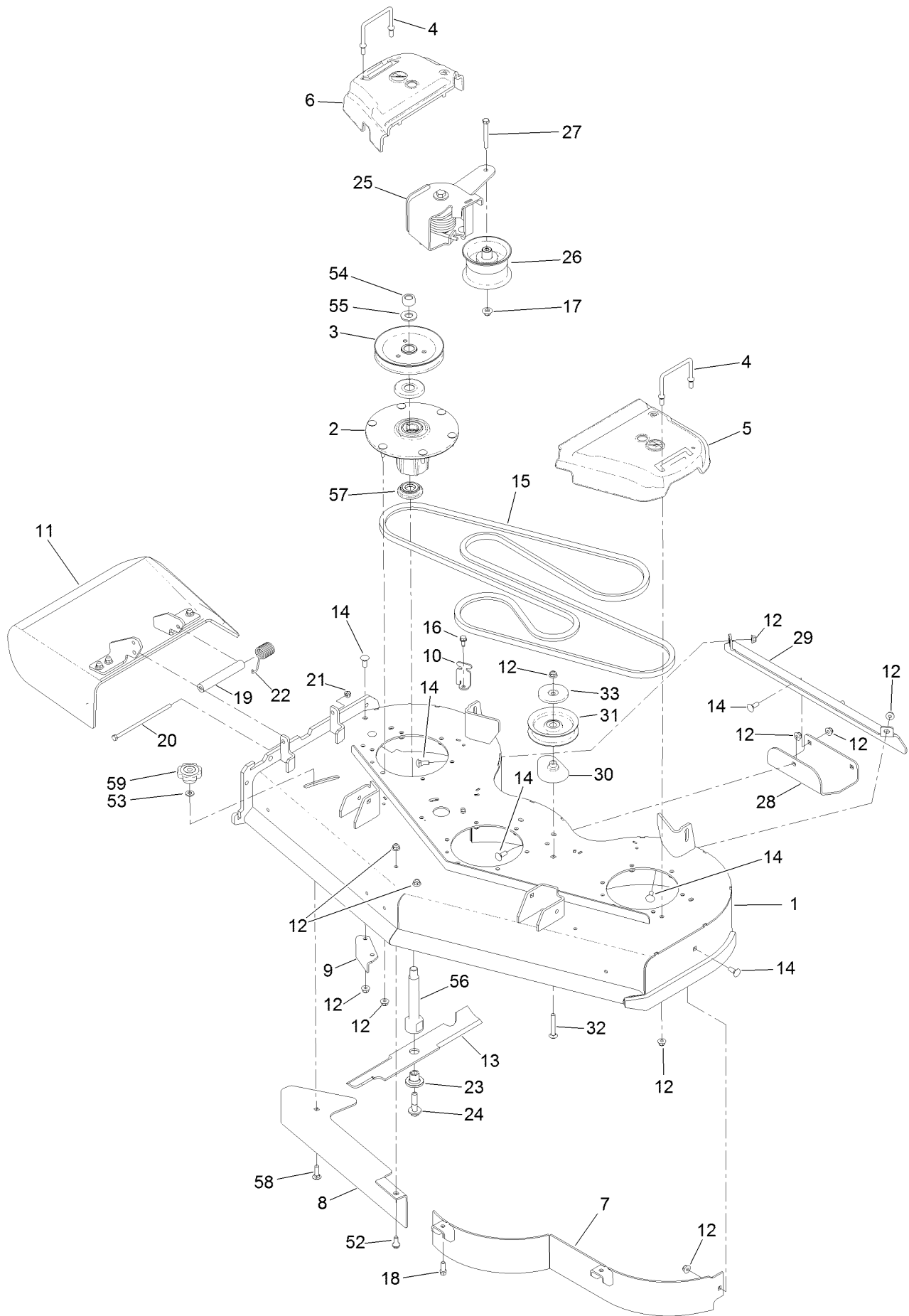

48 Inch Deck Assembly (continued)

<i>Ref.</i>	<i>Part Number</i>	<i>Qty.</i>	<i>Description</i>	<i>Ref.</i>	<i>Part Number</i>	<i>Qty.</i>	<i>Description</i>
1	139-8093	1	48 Deck ASM	22	108-4052	1	Spring-Torsion
2	137-9780	3	Spindle ASM	23	137-9787	3	Bushing-Hex
3	138-6061	3	Sheave-Blade, Drive	24	109-9220	3	Screw-Sems
4	109-6982	3	Wireform-Cover	25	145-3450	1	Gs Torsion Idler ASM li
5	109-6936	1	Cover-Belt, LH	26	127-1971	1	Pulley-Idler
6	109-6935	1	Cover-Belt, RH	27	323-20	1	Screw-HH
7	117-0410-01	1	48 Inch Baffle ASM	28	114-1908-01	1	Skid
8	139-8105-01	1	Plate-Baffle, Formed [red]	29	130-6649-01	1	Bracket-Skid
9	107-8541-01	1	Baffle-Discharge	30	109-2872	1	Spacer-Pulley
10	117-5758-03	4	Bracket-Cover	31	132-4718	1	Pulley-Idler, Flat
11	120-2451	1	Deflector ASM	32	3231-44	1	Screw-CARR
12	104-8301	39	Nut-HF, NI	33	132-5153	1	Shield-Dust
13	140-1243	3	Blade-16.50 High Flow	52	94-7582	1	Bolt-Shoulder
14	3231-2	8	Bolt-CARR	53	100-4852	1	Washer-Hardened
15	131-1121	1	Belt-V	54	116-7306	3	Nut-Hex
16	32144-70	4	Screw-HWHTF	55	103-2802	3	Washer
17	109-6658	1	Nut-Flange, NI	56	138-6045	3	Shaft-Spindle
18	92-1624	2	Screw-HWH Thd Form	57	137-9784	3	Guard-Bottom
19	105-4622	1	Spacer	58	3231-25	1	Bolt-CARR
20	322-50	1	Screw-HH	59	109-1092	1	Knob
21	104-8300	1	Nut-HF, NI				

Deck Decal Assembly No. 139-8093

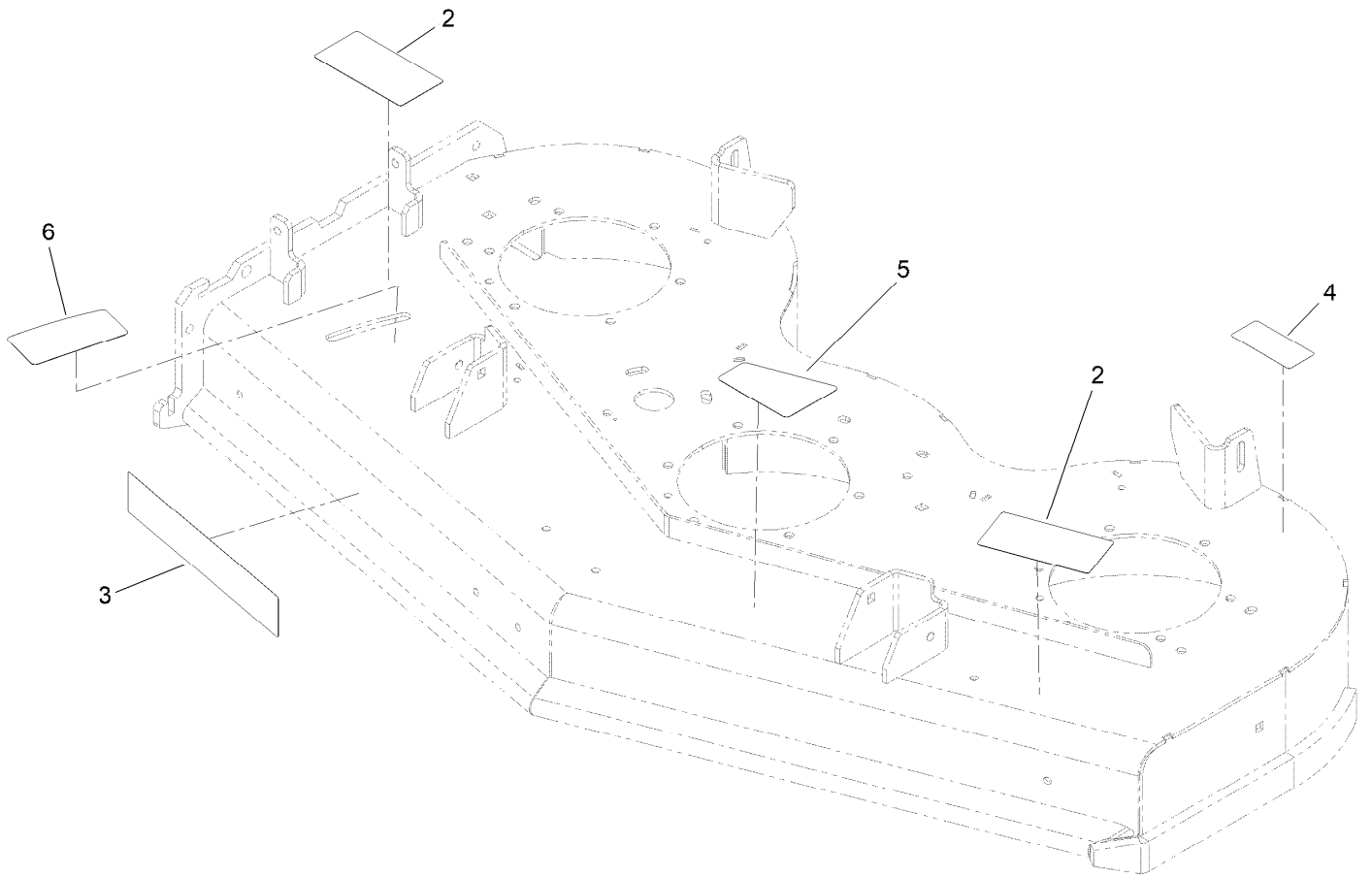

Deck Decal Assembly No. 139-8093 (continued)

<i>Ref.</i>	<i>Part Number</i>	<i>Qty.</i>	<i>Description</i>	<i>Ref.</i>	<i>Part Number</i>	<i>Qty.</i>	<i>Description</i>
2	133-4604	2	Decal-Danger	5	131-3507	1	Decal-Belt, Tension (CE)
3	107-1690	1	Decal	6	138-1147	1	Decal - Baffle Adjustment
4	116-8283	1	Decal-Torque, Bolt				

Spindle Assembly No. 137-9780



Spindle Assembly No. 137-9780 (continued)

<i>Ref.</i>	<i>Part Number</i>	<i>Qty.</i>	<i>Description</i>
2	116-0720	2	Bearing-Ball
3	138-6042	1	Spacer-Bearing

Deflector Assembly No. 120-2451



Deflector Assembly No. 120-2451 (continued)

<i>Ref.</i>	<i>Part Number</i>	<i>Qty.</i>	<i>Description</i>	<i>Ref.</i>	<i>Part Number</i>	<i>Qty.</i>	<i>Description</i>
1	3231-4	4	Screw-CARR	5	108-4059-01	1	Plate-Hinge, Rear
2	106-3246-01	1	Deflector	6	106-3253-01	1	Plate-Hinge, Front
3	106-3248-03	1	Strap-Discharge	7	104-8301	4	Nut-HF, NI
4	110-0759	1	Deflector-Rubber				

Ground Drive Assembly



Ground Drive Assembly (continued)

<i>Ref.</i>	<i>Part Number</i>	<i>Qty.</i>	<i>Description</i>	<i>Ref.</i>	<i>Part Number</i>	<i>Qty.</i>	<i>Description</i>
1	138-5838	1	LH Transmission ASM	20	3229-25	3	Screw-CARR
2	138-5839	1	RH Transmission ASM	21	104-7201	3	Nut-HF, NI
3	131-1131-03	1	Support-Transaxle	22		1	Gs Overflow Hose ASM ■
4	93-2569	4	Screw-HHF	23	109-0309	1	Hose-Fuel
5	116-4701	16	Screw-HHF	24	92-2379	1	Clamp-Hose
6	104-8301	18	Nut-HF, NI	25	131-7469	1	Rod-Bypass, RH
7	138-1108-03	1	Plate-Skid	26	131-7470	1	Rod-Bypass, LH
9	117-5351	1	Spacer	27	108-2992	2	Pin-Hair
10	1-413088	1	Bushing-Lever, Lift	28	32180-030	1	Clip-Tie
11	131-1175	1	Arm-Idler	29	140-1888	2	Wheel And Tire ASM
12	114-0463	2	Washer-Friction, Composite	29:1	140-1889	1	Rim-8 Inch Black
13	110-9981	1	Washer-Plain	29:2	120-6466	1	Tire
14	3234-39	1	Screw-HHF	29:3	232-27	1	Stem-Valve
15	93-1622	1	Pulley-Idler	30	242-50	8	Nut-Lug
16	3231-4	1	Screw-CARR	31	132-7584	2	Spacer-Hex
17	138-1104	1	Spring-Extension	32	104-8300	2	Nut-HF, NI
18	131-1124	1	Belt-V	33	3290-250	2	Pin-Cotter
19	132-1135	1	Tank-HYD	34	2412-129	2	Clamp-Hose
19:2	133-8677	1	Cap-Vented	35	3290-378	1	Tie-Cable
19:5	140-9463	1	Strainer-Neck, Removable ●				

● Not illustrated

■ Not serviced separately

LH Transmission Assembly No. 138-5838

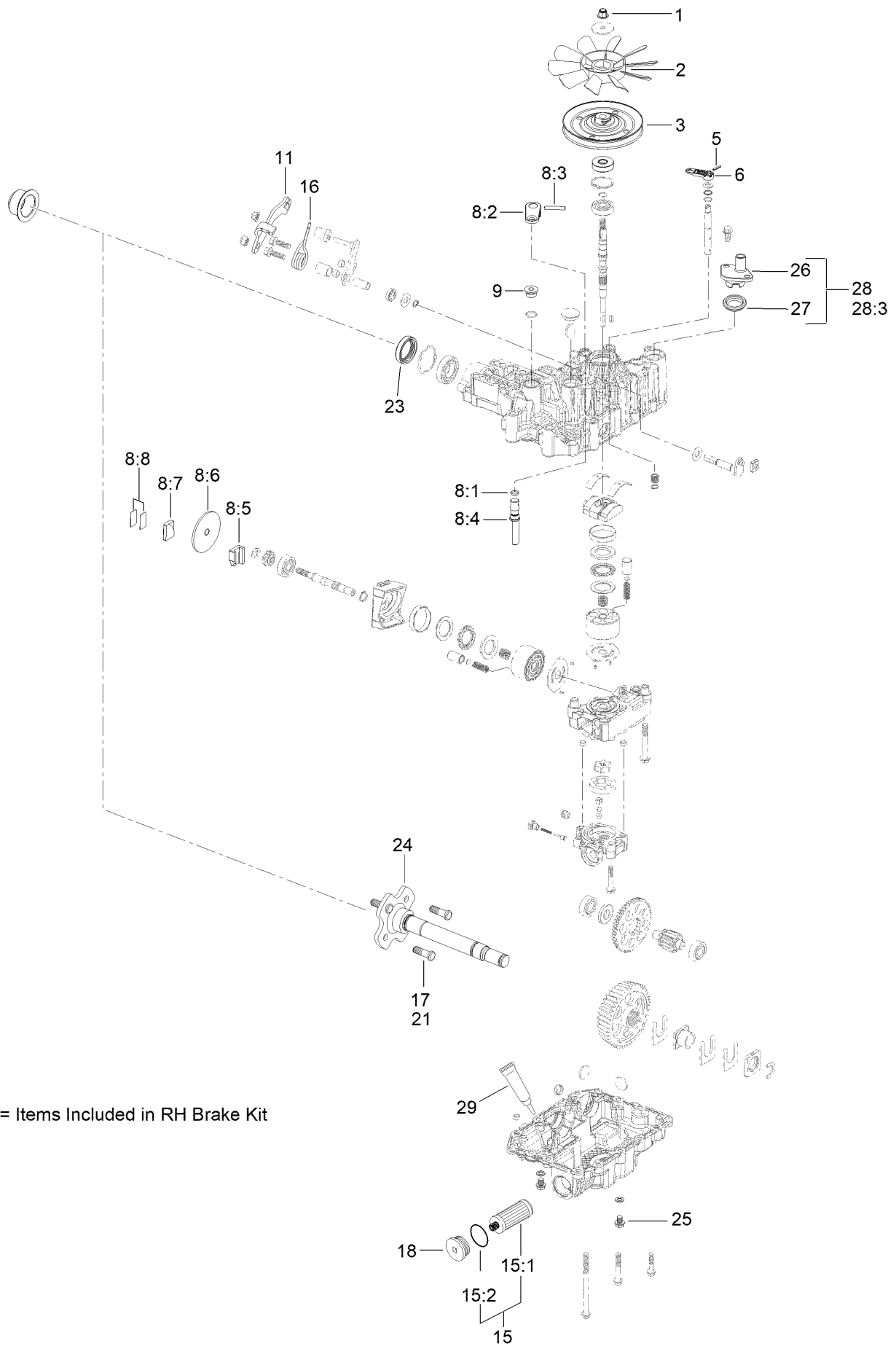

LH Transmission Assembly No. 138-5838 (continued)

<i>Ref.</i>	<i>Part Number</i>	<i>Qty.</i>	<i>Description</i>	<i>Ref.</i>	<i>Part Number</i>	<i>Qty.</i>	<i>Description</i>
1	132-4737	1	Nut-Lock	15	132-4743	1	Hydro Filter Kit
2	132-4738	1	Fan	15:1	136-5409	2	Filter
3	132-4739	1	Pulley	15:2	136-5410	2	O-Ring
5	104-3265	1	Pin	16	137-4109	1	Spring-Torsion
6	132-4700	1	Lever-Bypass	17	137-9509	4	Stud-Wheel
8	133-1468	1	Brake Kit,Left	18	138-4613	1	Cap-Oil Filter
8:1		1	O-Ring ●	21	137-9509	1	Stud-Wheel
8:2		1	Arm-Brake ●	23	139-5587	1	Seal-Axle, Ua
8:3		1	Pin-Roll ●	24	139-5588	1	Axle
8:4		1	Shaft-Brake ●	25	139-5589	2	Drain Bolt
8:5		1	Actuator-Brake ●	26	139-5590	1	Expansion Fitting
8:6		1	Disc-Brake ●	27	139-5591	1	Grommet Seal, Expansion Fitting
8:7		1	Shoe-Brake ●				
8:8		1	Shim Kit ●	28	139-7871	1	Expansion Fitting - W/ Seal
9	132-4735	1	Cap-Oil	28:3		1	M8*20 Flange Bolt ●
11	136-5401	1	Lever-Control, RH	29	138-4628	1	Seal Kit

● Not serviced separately

RH Transmission Assembly No. 138-5839

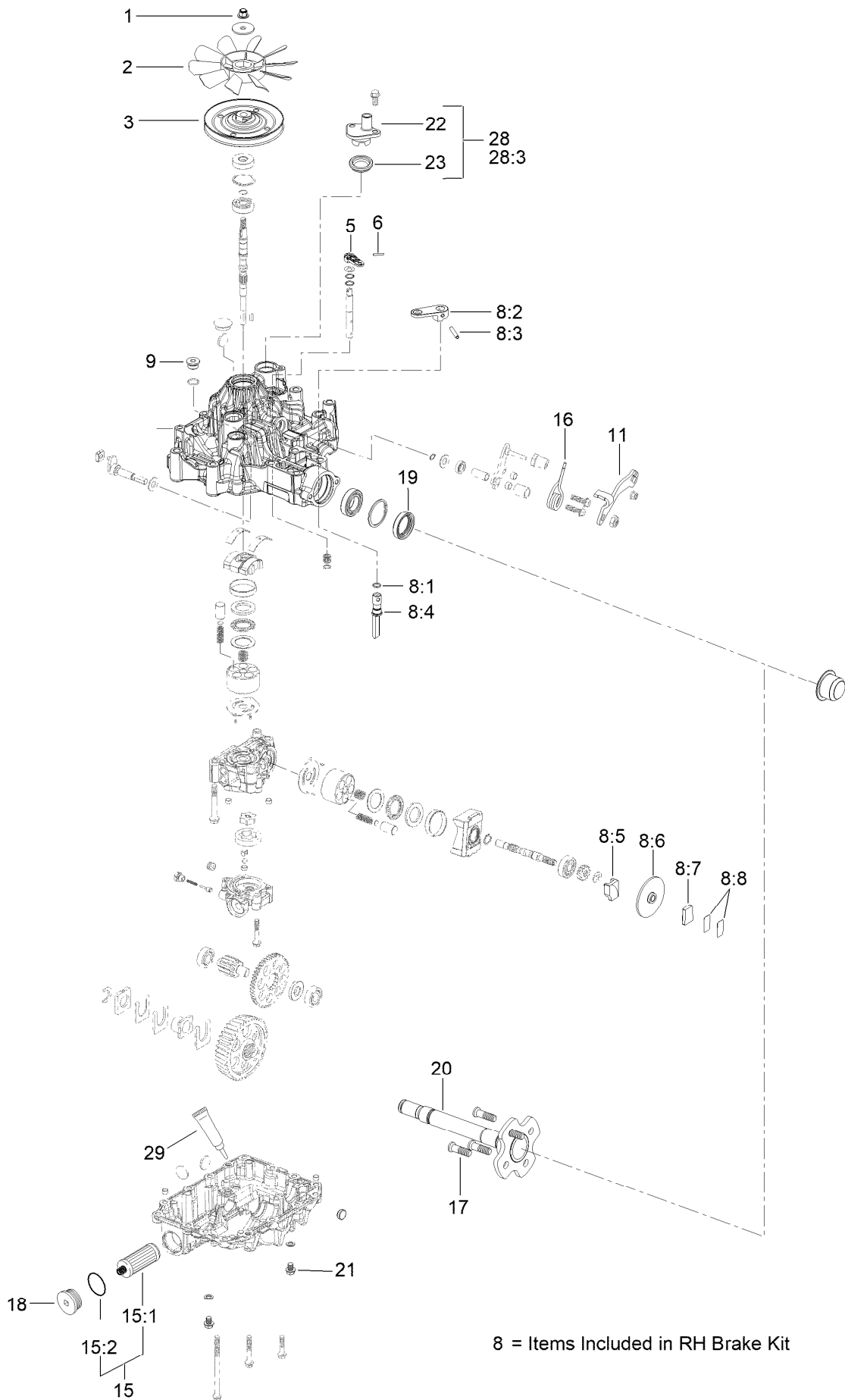

RH Transmission Assembly No. 138-5839 (continued)

<i>Ref.</i>	<i>Part Number</i>	<i>Qty.</i>	<i>Description</i>	<i>Ref.</i>	<i>Part Number</i>	<i>Qty.</i>	<i>Description</i>
1	132-4737	1	Nut-Lock	15	132-4743	1	Hydro Filter Kit
2	132-4738	1	Fan	15:1	136-5409	2	Filter
3	132-4739	1	Pulley	15:2	136-5410	2	O-Ring
5	104-3265	1	Pin	16	137-4109	1	Spring-Torsion
6	132-4700	1	Lever-Bypass	17	137-9509	4	Stud-Wheel
8	133-1462	1	RH Brake Kit	18	138-4613	1	Cap-Oil Filter
8:1		1	O-Ring ●	19	139-5587	1	Seal-Axle, Ua
8:2		1	Arm-Brake ●	20	139-5588	1	Axle
8:3		1	Pin-Roll ●	21	139-5589	2	Drain Bolt
8:4		1	Shaft-Brake ●	22	139-5590	1	Expansion Fitting
8:5		1	Actuator-Brake ●	23	139-5591	1	Grommet Seal, Expansion Fitting
8:6		1	Disc-Brake ●				
8:7		1	Shoe-Brake ●	28	139-7871	1	Expansion Fitting - W/ Seal
8:8		1	Shim Kit ●	28:3		1	M8*20 Flange Bolt ●
9	132-4735	1	Cap-Oil	29	138-4628	1	Seal Kit
11	136-5401	1	Lever-Control, RH				

● Not serviced separately

Overflow Hose Assembly



Overflow Hose Assembly (continued)

<i>Ref.</i>	<i>Part Number</i>	<i>Qty.</i>	<i>Description</i>	<i>Ref.</i>	<i>Part Number</i>	<i>Qty.</i>	<i>Description</i>
1	145-3444	1	Hose-Hydraulic	4	147-0201	1	R-Clamp
2	139-4055	1	Fitting Tee	5	147-0204	1	Hydraulic Hose
3	147-0202	1	Hydraulic Hose	6	145-3599	4	Hose Clamp

Motion Control Assembly



Motion Control Assembly (continued)

<i>Ref.</i>	<i>Part Number</i>	<i>Qty.</i>	<i>Description</i>	<i>Ref.</i>	<i>Part Number</i>	<i>Qty.</i>	<i>Description</i>
1	132-5157	1	LH Control Handle ASM	9:5	1-603807	1	Spring-Return, Neutral
2	132-5158	1	RH Control Handle ASM	10	138-4620	1	RH Control Rod ASM
3	119-0222	2	Grip	10:1	138-4647	1	Ball Joint-LH
4	103-9928	2	Bearing	10:2	138-4648	1	Ball Joint-RH
5	120-3288	1	Tab-Pivot, LH	10:4	3219-3	1	Nut-Hex
6	3229-1	4	Screw-CARR	11	3231-28	2	Screw-CARR
7	104-7201	6	Nut-HF, NI	12	104-8301	4	Nut-HF, NI
8	120-3287	1	Tab-Pivot, RH	13	3256-24	2	Washer-Plain
9	138-4619	1	LH Control Rod ASM	14	132-7538	1	Bracket-Adjustment, Speed
9:1	138-4647	1	Ball Joint-LH	15	126-1499	2	Cam
9:2	138-4648	1	Ball Joint-RH	16	323-7	2	Screw-HH
9:4	3219-3	1	Nut-Hex				

Control Handle Assembly No. 132-5157



Control Handle Assembly No. 132-5157 (continued)

<i>Ref.</i>	<i>Part Number</i>	<i>Qty.</i>	<i>Description</i>	<i>Ref.</i>	<i>Part Number</i>	<i>Qty.</i>	<i>Description</i>
2	131-3562	1	Bearing-Sleeve	7	116-2670	1	Screw-Shoulder
4	323-10	1	Screw-HH	8	104-8300	1	Nut-HF, NI
5	104-8301	1	Nut-HF, NI	9	132-5146	1	Spring-Extension
6	110-7191	2	Washer-Thrust				

Control Handle Assembly No. 132-5158



Control Handle Assembly No. 132-5158 (continued)

<i>Ref.</i>	<i>Part Number</i>	<i>Qty.</i>	<i>Description</i>	<i>Ref.</i>	<i>Part Number</i>	<i>Qty.</i>	<i>Description</i>
3	104-8301	1	Nut-HF, NI	7	104-8300	1	Nut-HF, NI
4	323-10	1	Screw-HH	8	131-3562	1	Bearing-Sleeve
5	110-7191	2	Washer-Thrust	9	132-5146	1	Spring-Extension
6	116-2670	1	Screw-Shoulder				

Parking Brake Assembly



Parking Brake Assembly (continued)

<i>Ref.</i>	<i>Part Number</i>	<i>Qty.</i>	<i>Description</i>	<i>Ref.</i>	<i>Part Number</i>	<i>Qty.</i>	<i>Description</i>
1	132-5170	1	Brake Handle ASM	7	32144-4	2	Screw-HWH
2	3230-23	5	Bolt-CARR	8	132-1187	1	Clamp-Cable
3	104-8300	6	Nut-HF, NI	9	132-7582	1	Mount-Cable, Brake
4	132-5168	1	RH Brake Caliper ASM	10	1-633268	1	Grip-Lever
5	132-5169	1	LH Brake Caliper ASM	11	131-1195	2	Cable-Brake
6	104-8301	2	Nut-HF, NI				

Deck Lift Assembly (continued)

<i>Ref.</i>	<i>Part Number</i>	<i>Qty.</i>	<i>Description</i>	<i>Ref.</i>	<i>Part Number</i>	<i>Qty.</i>	<i>Description</i>
1	120-8405-01	1	Shaft-Cross, Front	25	3231-7	4	Screw-CARR
2	109-9409	2	Support-Bearing, Cross Shaft (Front)	26	104-8301	7	Nut-HF, NI
3	109-9410	2	Bearing-Cross Shaft, Front	27	32128-19	4	Nut-HF Lock, Large Flg
4	116-1700	4	Bolt-CARR	28	109-9066	4	Yoke-Adjust, Deck
5	99-5107	8	Nut-Lock	29	322-47	4	Screw-HH
6	127-0369	6	Bushing	30	3218-2	8	Nut-Hex Jam
7	10-8110	3	Washer-Thrust	31	130-6589	2	Link-Lift
8	3256-62	3	Washer-Flat	32	109-9840	2	Screw-Shoulder, HHF
9	120-8411-01	1	Arm-Lift, RH	33	109-9065	2	Screw-HH
10	32151-29	3	Ring-Retaining	34	116-2428	2	Bushing-Flanged
11	120-8410-01	1	Arm-Lift, LH	35	3256-4	2	Washer-Flat
12	161-6735	1	HOC Lever ASM	36	3296-48	4	Nut-Hex
13	119-6223	2	Washer	37	95-6448	2	Spacer
14	138-4932	3	Nut-Hex Flg	38	138-1111	1	Spacer
15	138-4931	3	Screw-Lock	39	132-7581	1	HOC Plate And Decal ASM
16	130-6615	1	HOC Link ASM	40	138-4887	1	Plate-HOC, Inner
17	3218-6	1	Nut-Jam	41	116-4701	3	Screw-HHF
18	98-5975	1	Washer-Belleville	42	121-1760	2	Spacer
19	323-58	1	Bolt-TAP, HH	43	116-5584	1	Pin-HOC
20	116-0886	1	Spring-Extension	44	116-0756	2	Deck Lift Chain ASM
21	116-0780	4	Screw-Shoulder, HHF	44:1	1-633447	1	Chain-Lift, Deck
22	3256-28	4	Washer-Flat	44:2	109-9065	1	Screw-HH
23	127-1948-03	2	Link-Lift	44:3	32128-37	1	Nut-HF
24	137-4129	1	Deck Strut ASM	45	130-0742	2	Bolt-Shoulder
24:2	137-4108	4	Bushing-Rubber	46	43-0940	2	Spacer
24:3	108-6544	4	Spacer	47	133-1431	1	Spacer-Split

HOC Lever Assembly No. 161-6735

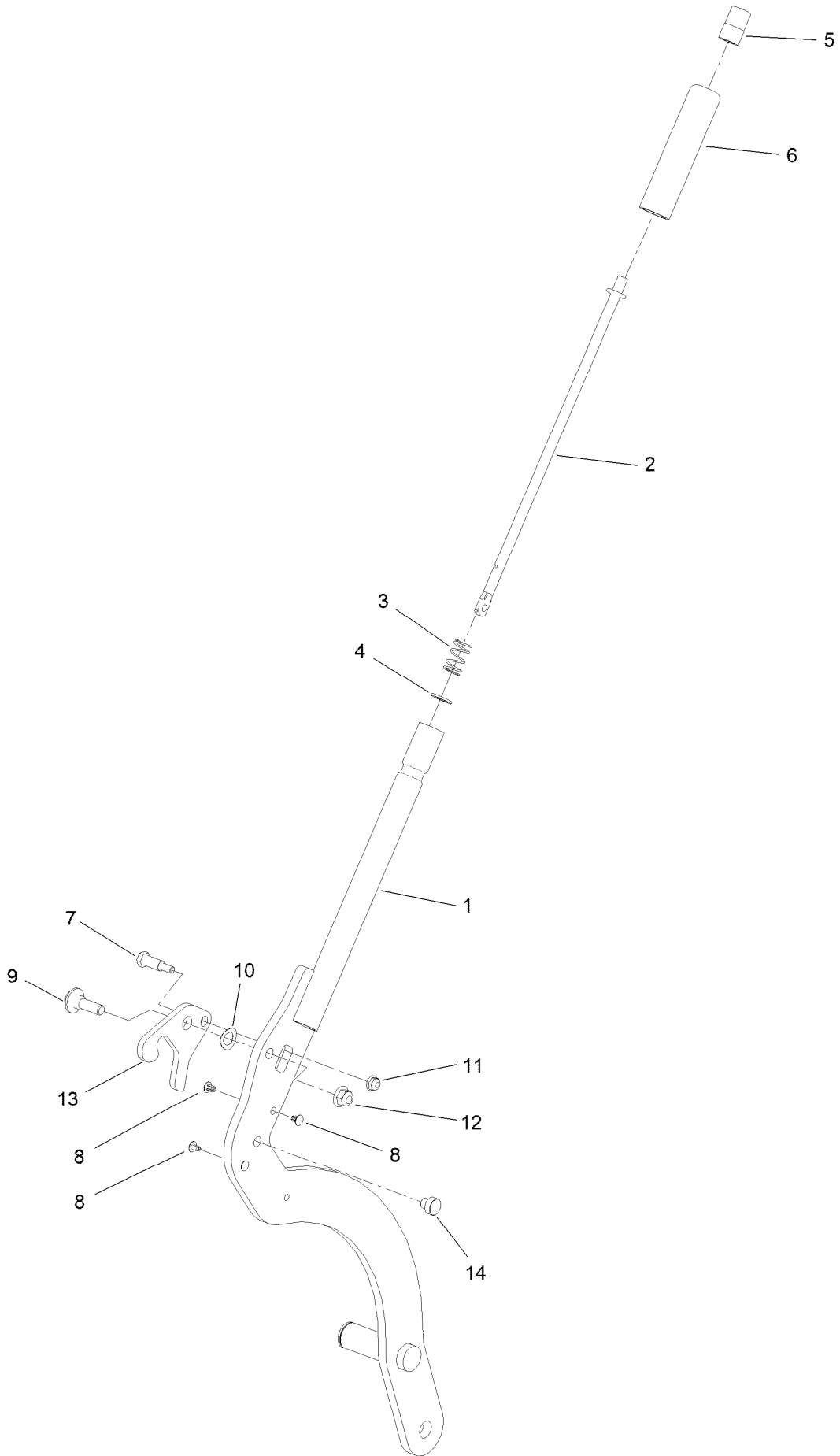

HOC Lever Assembly No. 161-6735 (continued)

<i>Ref.</i>	<i>Part Number</i>	<i>Qty.</i>	<i>Description</i>	<i>Ref.</i>	<i>Part Number</i>	<i>Qty.</i>	<i>Description</i>
1	161-6736-01	1	Lift Lever ASM [red]	8	103-1363	4	Rivet
2	136-0530	1	Rod-Latch, Release	9	614672	1	Screw-Shoulder, HWH
3	114-8187	1	Spring-Compression	10	110-8982	1	Washer-Spring
4	114-1207	1	Washer-Special	11	104-7201	1	Nut-HF, NI
5	115-2750	1	Knob	12	104-8301	1	Nut-HF, NI
6	115-3592	1	Grip	13	138-4888	1	Latch-HOC
7	119-2309	1	Bolt-Shldr,HH	14	138-4863	1	Plug-Wear

HOC Link Assembly No. 130-6615

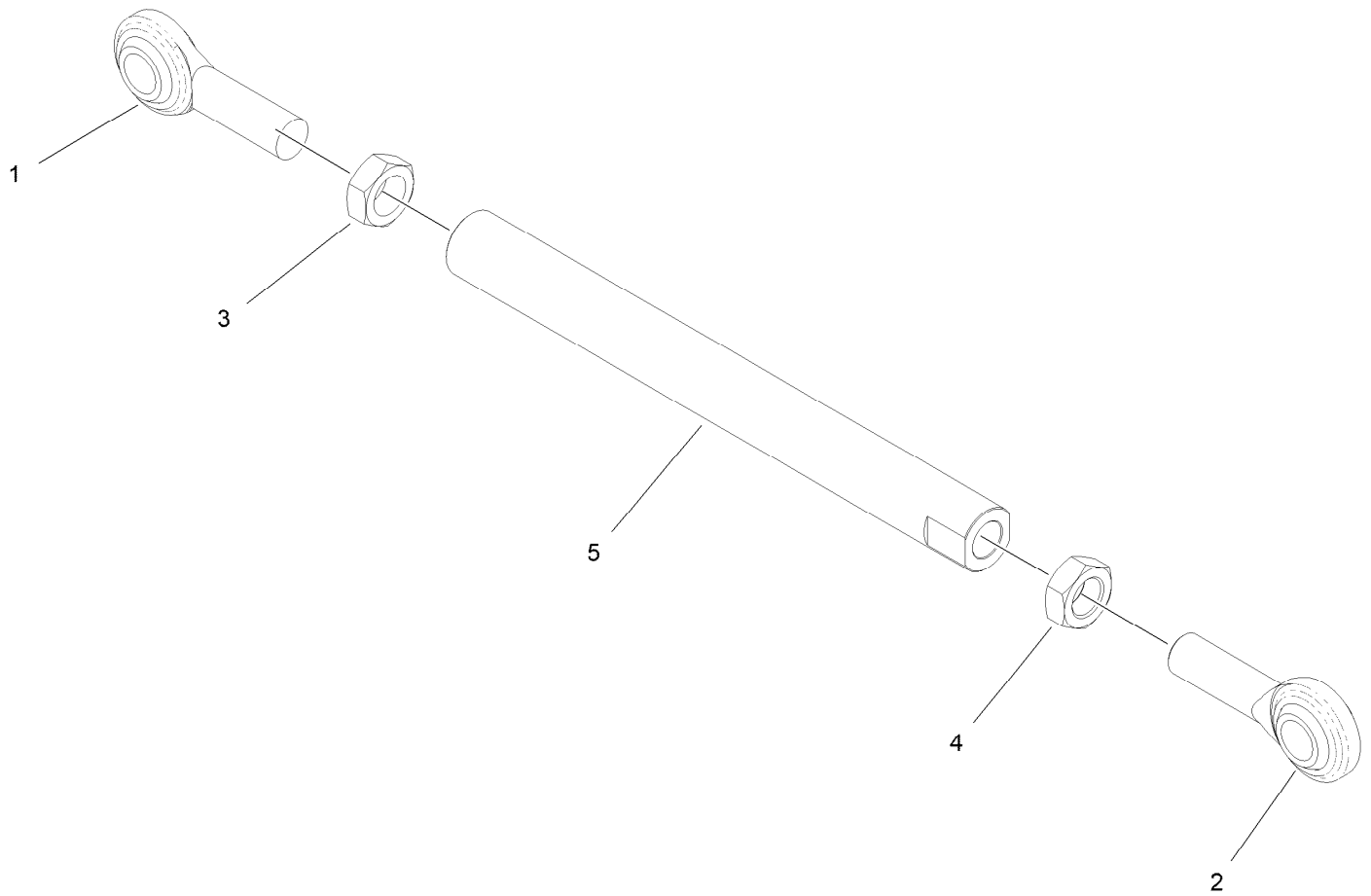

HOC Link Assembly No. 130-6615 (continued)

<i>Ref.</i>	<i>Part Number</i>	<i>Qty.</i>	<i>Description</i>
1	1-633029	1	Balljoint-Spherical
2	117-5291	1	Balljoint-Spherical
3	3220-6	1	Nut-Jam

<i>Ref.</i>	<i>Part Number</i>	<i>Qty.</i>	<i>Description</i>
4	117-5293	1	Nut-Jam
5	130-6614	1	Link-Height Of Cut

Frame Assembly

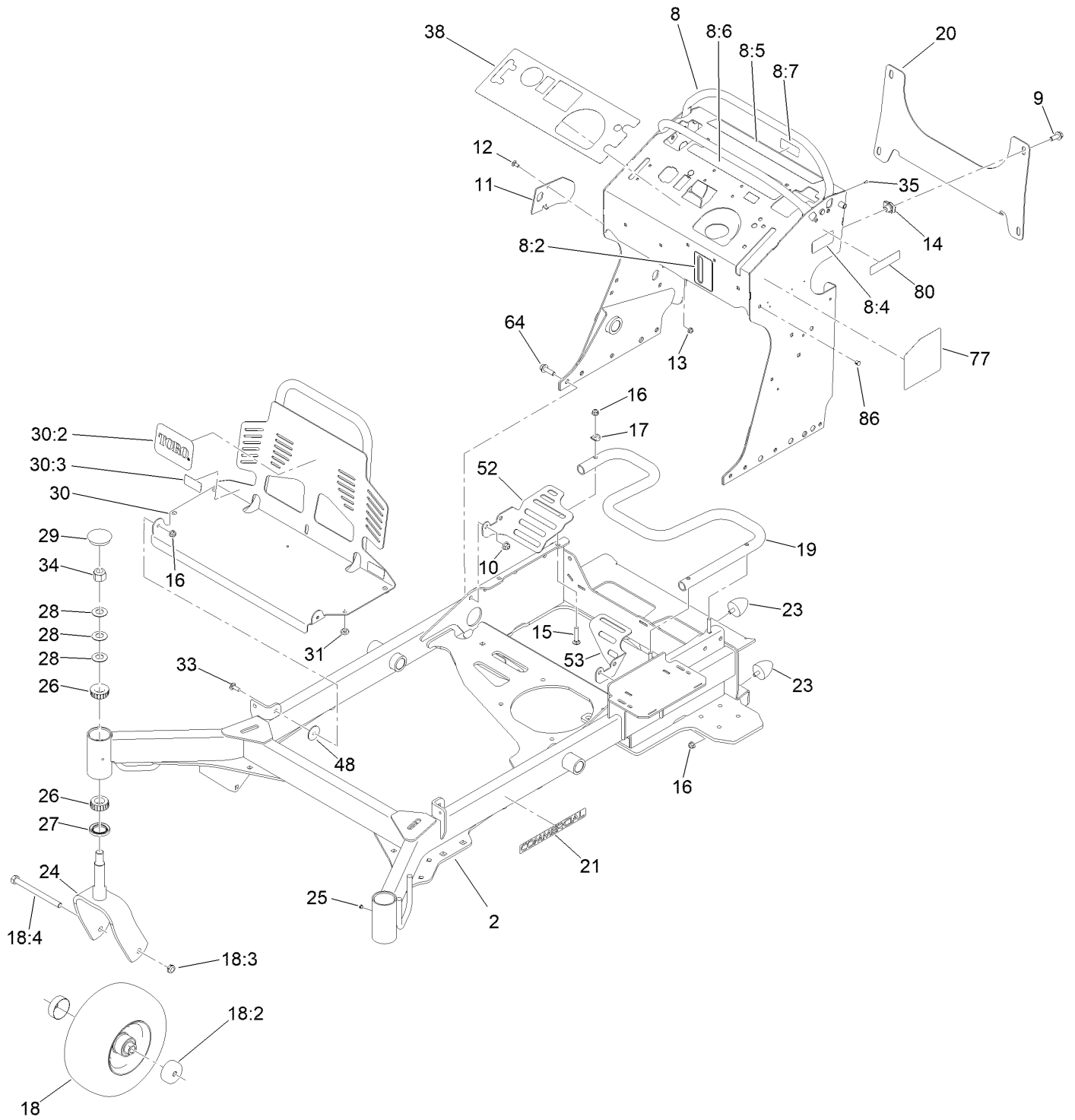

Frame Assembly (continued)

<i>Ref.</i>	<i>Part Number</i>	<i>Qty.</i>	<i>Description</i>	<i>Ref.</i>	<i>Part Number</i>	<i>Qty.</i>	<i>Description</i>
2	131-7423-01	1	Frame	23	114-1926	4	Bumper-Rubber
8	140-4283	1	Tower Decal ASM	24	147-6343-01	2	Caster Fork ASM [red]
8:2	147-7921	1	Decal-Oil Level	25	1-811010	2	Plug
8:4	116-8775	1	Decal-Fill, Fuel	26	1-543509	4	Bearing-Roller, Tapered
8:5	139-2878	1	Decal-Warning	27	116-5647	2	Seal-Grease
8:6	131-3526	1	Decal-Controls	28	1-633508	6	Washer-Bellville
8:7	147-0212	1	Decal - Fuse	29	103-4882	2	Cap-Grease
9	3234-42	4	Screw-HHF	30	161-3586	1	Engine Guard ASM W/Decals
10	104-8301	8	Nut-HF, NI	30:2	105-8278	1	Decal
11	131-7455	1	Plate-Striker	30:3	133-4641	2	Decal-Warning, No Riders
12	3229-11	1	Screw-CARR	31	1-513658	4	Bumper
13	104-7201	1	Nut-HF, NI	33	3230-10	2	Bolt-CARR
14	105-4886	4	Nut-Tinnerman	34	3296-51	2	Nut-Lock, NI
15	3230-5	3	Bolt-CARR	35	3290-271	2	Rivet-Pop
16	104-8300	9	Nut-HF, NI	38	140-4258	1	Decal-Panel, Control
17	107-3844	3	Washer	48	107-3002	2	Washer-Nylon
18	140-5485	2	Mf Wheel Tire Bearing ASM	52	132-7578-01	1	Guard-Fan, RH
18:2	103-2768	2	Guard-Seal	53	132-7598-01	1	Guard-Fan, LH
18:3	3296-45	1	Nut-Hex	64	119-4061	8	Screw-HHF
18:4	325-20	1	Screw-HH	77	131-3529	1	Decal-Service Aid
19	132-5161-01	1	Tube-Mount, Fuel Tank	80	133-8062	1	Decal-Spark Arrestor
20	132-1145-03	1	Bracket-Cross	86	145-3595	3	Dome Panel Plug
21	117-3591	2	Decal-Commercial				

Wheel and Bearing Assembly



Wheel and Bearing Assembly (continued)

<i>Ref.</i>	<i>Part Number</i>	<i>Qty.</i>	<i>Description</i>	<i>Ref.</i>	<i>Part Number</i>	<i>Qty.</i>	<i>Description</i>
1	1-633585	2	Bearing-Cone, Taper	4	126-5359	1	Caster Axle ASM
2	103-0063	2	Seal-Caster	5	140-5483	1	Mf Wheel And Tire ASM
3	103-3051	1	Spacer-Nut				

Platform Assembly

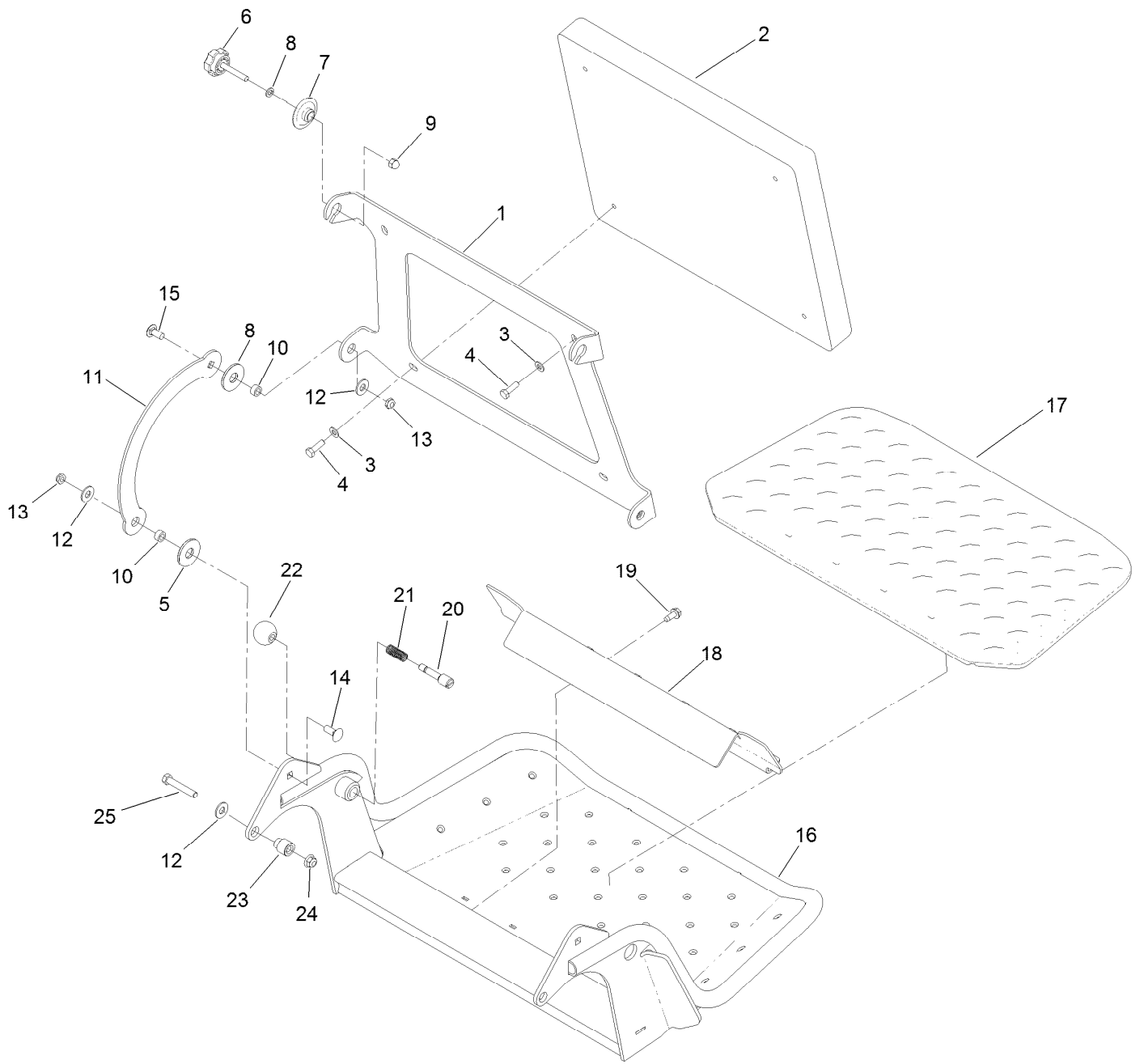

Platform Assembly (continued)

<i>Ref.</i>	<i>Part Number</i>	<i>Qty.</i>	<i>Description</i>	<i>Ref.</i>	<i>Part Number</i>	<i>Qty.</i>	<i>Description</i>
1	120-8499-03	1	Hinge-Pad	14	3231-2	2	Bolt-CARR
2	117-9739	1	Pad-Cushion	15	3231-27	2	Screw-CARR
3	3256-23	4	Washer-Plain	16	161-6796-01	1	Platform ASM [red]
4	121-7999	4	Screw-HH, Patch	17	126-7157	1	Mat-Platform
5	114-0463	4	Washer-Friction, Composite	18	3345-771	1	Shield Clamp Kit
6	133-1426	2	Knob	19	32144-70	2	Screw-HWHTF
7	116-2886	2	Slide-Bushing	20	119-8650	1	Pin-Latch
8	3253-4	2	Washer-Lock	21	114-5348	1	Spring
9	137-4808	2	Nut-Acorn	22	1-603175	1	Knob-Ball
10	111044	4	Spacer	23	132-7583	2	Bushing-Flanged
11	114-1915-01	2	Link-Pad	24	104-8301	2	Nut-HF, NI
12	3256-4	6	Washer-Flat	25	323-45	2	Screw-HH
13	3296-59	4	Nut-Lock, NI				

Engine Assembly

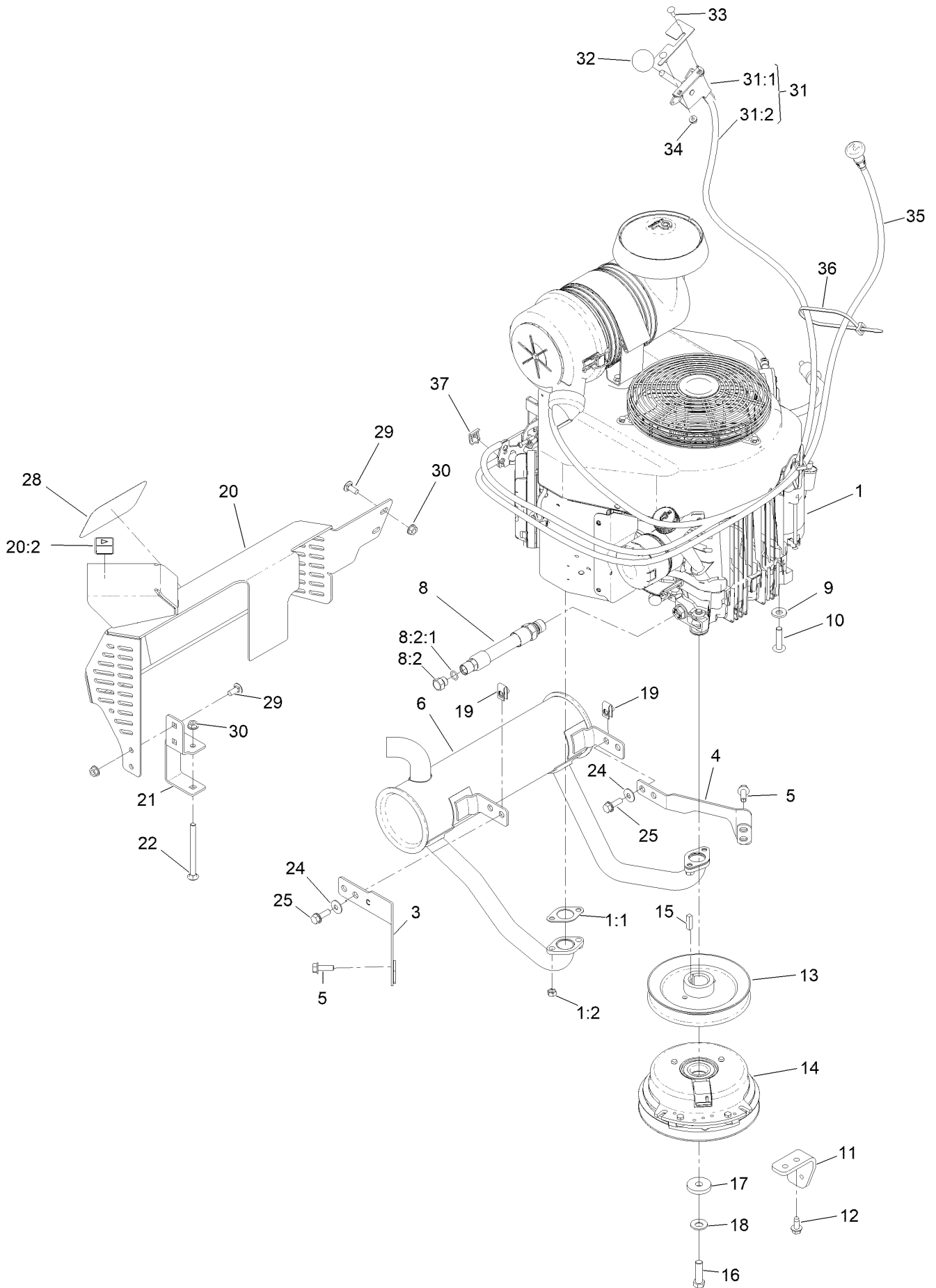

Engine Assembly (continued)

<i>Ref.</i>	<i>Part Number</i>	<i>Qty.</i>	<i>Description</i>	<i>Ref.</i>	<i>Part Number</i>	<i>Qty.</i>	<i>Description</i>
1		1	Engine Kawasaki, Fx691V ■	18	1-603610	1	Washer-Spring
			▲	19	94-2413	4	Nut-U
1:1	1-653313	2	Gasket-Exhaust	20	131-3550	1	Muffler Guard ASM
1:2	114-3549	4	Nut	20:2	106-5517	1	Decal-Warning
1:5	119-5945	1	Element-Filter, Air (Inner) ●	21	131-3530-03	1	Bracket-Mounting, Guard
1:6	119-5944	1	Element-Filter, Air (Outer) ●	22	106-9758	1	Screw-CARR
1:7	95-9853	1	Bolt (5X18) ●	24	3290-456	4	Washer-Belleville
3	132-1173	1	Bracket-Muffler, Front	25	3234-29	4	Screw-HHF
4	132-1174	1	Bracket-Muffler, Rear	28	94-2579	1	Decal
5	33104-025	4	Screw-HHF	29	3230-23	4	Bolt-CARR
6	133-4633	1	Muffler	30	32128-25	5	Nut-HF
8	133-4659	1	Hose ASM	31	147-1664	1	Throttle ASM
8:2	353-508	1	Plug-HH	31:1	145-6187	1	Lever-Control
8:2:1	237-42	1	O-Ring	31:2	147-1674	1	Cable-Throttle
9	98-5975	4	Washer-Belleville	32	1-603175	1	Knob-Ball
10	126-0983	4	Screw-BHTF	33	1-807533	2	Bolt-CARR
11	131-3586-03	1	Stop-Clutch	34	32128-17	2	Nut-Lock, Flange
12	32144-70	2	Screw-HWHTF	35	132-5140	1	Cable-Choke
13	120-8498	1	Pulley	36	3290-378	1	Tie-Cable
14	139-7910	1	Clutch-200Cms	37	81-1690	1	Clamp-Cable
15	1-807259	1	Key	39	121-4570	1	Filter-Fuel ●
16	3212-6	1	Screw-HH	40	119-5852	1	Filter-Oil ●
17	107-4136	1	Washer-Flat				

● Not illustrated

▲ Obtain parts from www.kawpower.com

■ Not serviced separately

Fuel Tank Assembly



Fuel Tank Assembly (continued)

<i>Ref.</i>	<i>Part Number</i>	<i>Qty.</i>	<i>Description</i>	<i>Ref.</i>	<i>Part Number</i>	<i>Qty.</i>	<i>Description</i>
1	132-7560	1	Fuel Tank ASM	2	110-8255	1	Hose-Fuel
1:2	46-6560	2	Bushing	3	98-2952	1	Fitting-Straight
1:3	137-4127	1	Cap-Fuel	4	132-7576	1	Hose-Fuel
1:4	104-5228	1	Fitting-Elbow, 90 DEG	5	132-7546	1	Fuel Line ASM
1:5	145-6195	1	ASM, Tube-Fuel				

Electrical Assembly

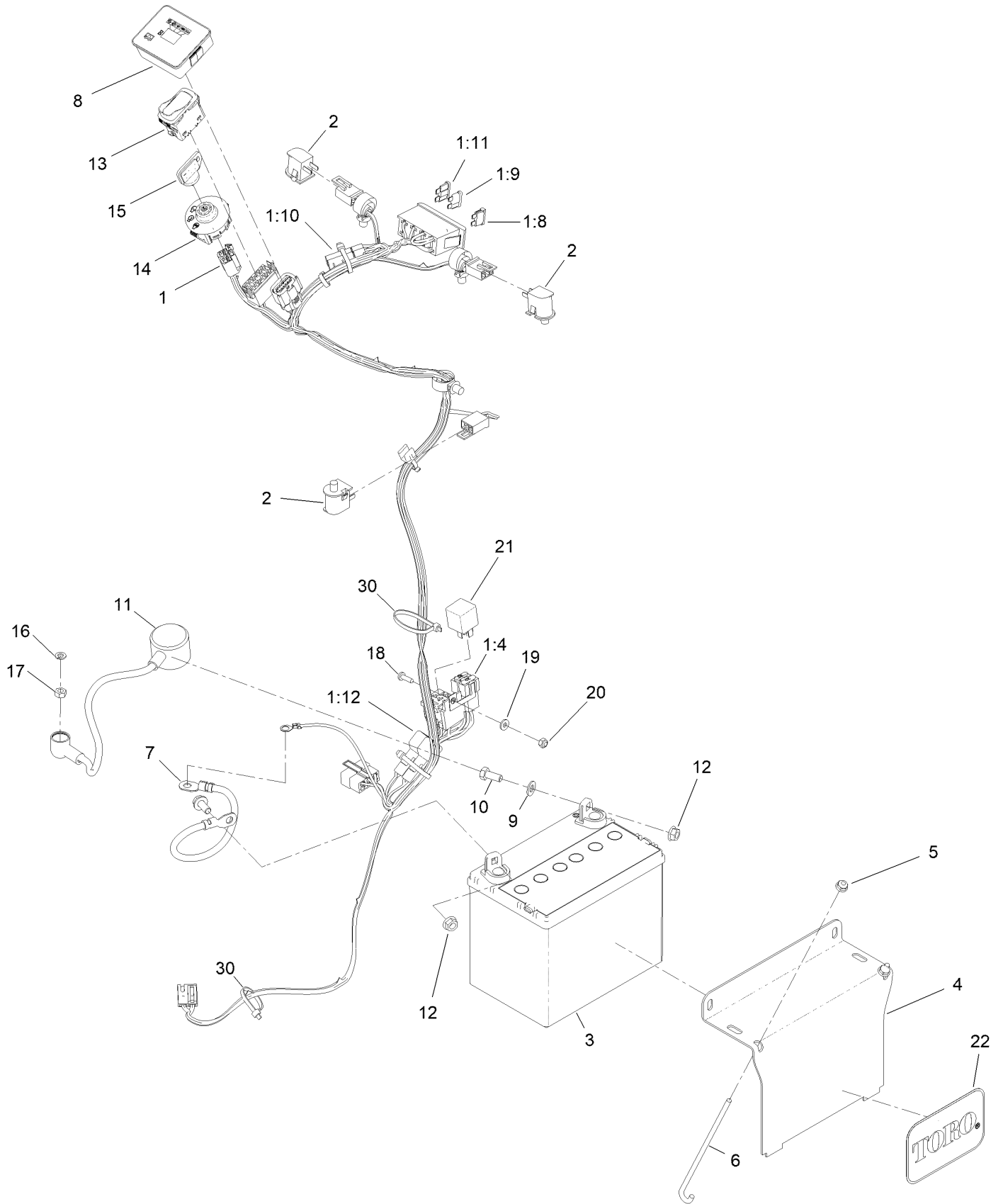

Electrical Assembly (continued)

<i>Ref.</i>	<i>Part Number</i>	<i>Qty.</i>	<i>Description</i>	<i>Ref.</i>	<i>Part Number</i>	<i>Qty.</i>	<i>Description</i>
1	145-5228	1	Harness-Wire, Grandstand	10	322-3	2	Screw-HH
1:4	109101	1	Fuse-Blade, 20 Amp	11	115-3864	1	Cable-Battery, Positive
1:8	109355	2	Fuse-Blade, 15 Amp	12	109-5715	2	Nut-HHF, Smooth
1:9	218-578	1	Fuse-Blade, 10 Amp	13	139-6367	1	Switch-Rocker, (On)-On-Off
1:10	116-0053	2	Cap-Plug	14	137-4101	1	Switch-Ignition
1:11	110928	1	Fuse-Blade, 5 Amp	15	63-8360	1	Key-Ignition
1:12	109103	1	Fuse-Blade, 30 Amp	16	3253-3	1	Washer-Lock
2	82-2190	3	Switch-Bail	17	3217-5	1	Nut-Hex
3	104-8162	1	Battery	18	3290-500	1	Screw-PPH
4	130-6635-01	1	Bracket-Hold Down, Battery	19	3256-14	1	Washer-Flat
5	104-7201	2	Nut-HF, NI	20	3296-2	1	Nut-Lock, NI
6	1-633651	2	Bolt-Holddown	21	1-643275	1	Relay
7	112-7063	1	Cable-Battery, Black	22	67-1300	1	Decal
8	140-1884	1	Module-Meter, Hour	30	3290-378	2	Tie-Cable
9	3256-23	2	Washer-Plain				

Attachments and Accessories

For 72504 GrandStand Mower With 48in TURBO FORCE Cutting Unit

Product Name	Model/Part
Hypr-Oil 500 (quart)	114-4713
Hypr-Oil 500 (gallon).....	114-4714
Hypr-Oil 500-5 (5 gallon).....	114-4715
Oil Filter	119-5852
Element-Filter, Air (Outer).....	119-5944
Element-Filter, Air (Inner).....	119-5945
Fuel Filter.....	120-2235
Harness Wire Splitter.....	121-5988
Toro Premium Fuel Treatment 12oz Bottle.....	131-6572
Speed Setting Tool.....	132-7595
Stand-On Weight Kit	133-1428
Chute Gate Kit W/ Bag.....	133-1434
Trash Bag Assembly.....	133-1435
Roller Striper Kit.....	133-1436
Light Kit.....	133-1437
Electric Accessory Port.....	133-1438
HOC Set Blocks.....	133-1439
Anti-Scalp Kit, 48/52 Grandstand Deck.....	133-1440
Trimmer Rack	133-1441
Hydro Oil Change Kit	133-1457
Strobe Light Kit	133-1495
5 Gallon Bucket	133-2533
Hydraulic Cap Lock Kit.....	136-5420
Bucket Mount Kit.....	136-5681
Bagger Enhancement Kit.....	139-1529
Recycler Kit	139-6650
18x8.5n10 X-Tweel Turf.....	139-7890
Blade-16.50 High Flow	140-1243
Pneumatic Castor Wheel Kit.....	140-4311
Blade-16.50 Medium Flow	140-4860
Blade-16.50 Low Flow	140-4861
Blade-16.50 Atomic	140-4862
Blade-16.50 Recycler	140-4863
6 Pack-Blade, 16.5 High Flow.....	140-4887
6 Pack-Blade, 16.5 Med Flow	140-4888
6 Pack-Blade, 16.5 Low Flow	140-4889
6 Pack-Blade, 16.5 Atomic.....	140-4890
6 Pack-Blade, 16.5 Recycler.....	140-4891
2 Transmission Filter Kit	144-3842
Blade-16.50 High Flow	147-6250
6 Pack-Blade, 16.50 High Flow.....	147-6254
Soft Bag (3 Bushel).....	30104
10W30 4-Cycle Engine Oil (32oz Bottle).....	38280
Toro 4-Cycle SAE 30 Oil (32oz Bottle)	38903
Twin Bagger Kit.....	78524
Blower Drive 48In	78525

Attachments and Accessories (continued)

Spark Plug 92-2153
Spark Arrestor 98-9099



Count on it.