

# TABLE OF CONTENTS

---

CHAPTER	PAGE
Table Of Contents . . . . .	1-1
Time Savers . . . . .	2-1
Glossary . . . . .	3-1
825 . . . . .	4-1
12-32 . . . . .	5-1
XL . . . . .	6-1
266-H . . . . .	7-1
268-H . . . . .	8-1
270-H . . . . .	9-1
315-8 . . . . .	10-1
416XT . . . . .	11-1
417XT . . . . .	12-1
419XT . . . . .	13-1
5xi . . . . .	14-1
Z16-44 / 16-44ZX . . . . .	15-1
Z17-44 / Z17-52 / 17K-44ZX / 17-52ZX . . . . .	16-1
Z18-52 / 18-52ZX . . . . .	17-1
14-38Z / 16-42Z . . . . .	18-1
17-42Z . . . . .	19-1
Twister Vehicle . . . . .	20-1
1332-G International . . . . .	21-1
1332-H International . . . . .	22-1
170-D International . . . . .	23-1
190-D International . . . . .	24-1

**This page intentionally left blank**

## Table of Contents

Using this Manual.....	2 - 1
Using a VOM.....	2 - 7
Troubleshooting.....	2 - 9

## GLOSSARY

The Glossary contains information on virtually every electrical part used on Toro riding products.

The components are listed alphabetically by noun, followed by any adjectives. If you have trouble finding a component, use the Table of Contents at the front of the Glossary section.

### Low Voltage Module, Low Voltage

The illumination of the battery light on the dash indicates the battery voltage is too low. This is sensed through the low voltage module (Figure 13).

#### How it works

The low voltage module is a voltage comparator, checking the battery voltage against a 12 volt D.C. reference. When the battery voltage drops below 12 volts, the module activates until the battery voltage rises above 12 volts.

These three sections should be all you need to diagnose problems on individual components.

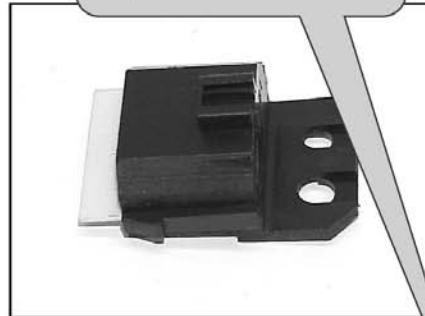

Figure 13 mvc-38

#### Testing

1. Before replacing the low voltage module, test the battery to make sure it is fully charged and is in good shape.
2. Next, check the charging system of the engine; follow the procedure in the Kohler Engine Service Manual.
3. If the battery checks out and is in good condition and the charging system checks out and is charging properly and the battery light on the dash is on, replace the low voltage module. Without specialized test equipment, it is not practical to test the low voltage module in the field.

#### Purpose

The relay monitors current in one circuit. If current is present, it flips an SPDT switch to the other position.

#### How It Works

A relay is an electrically actuated switch.

1. Coil: Terminals 85 and 86 are connected to a coil. Applying 12 volts to these terminals energizes the coil turning it into an electromagnet.
2. Switch: Terminals 30, 87, and 87a are actually part of a single pole, double throw (SPDT) switch. Terminal 30 is the common lead. The switch is spring loaded so that 30 and 87a are connected when the coil is not energized. When the coil is energized, the switch is "thrown" and 30 and 87 are connected (Figure 14).



Figure 14 MVC-671

#### Testing

1. Disconnect the relay from the harness.
2. Verify the coil resistance between terminals 85 and 86 with a multimeter (ohms setting). Resistance should be from 70 to 90 ohms. There should be continuity between terminals 87a and 30 (Figure 15).



**2002 - 2003**

Each product series has its own section including:  
- Info List  
- Wiring Diagrams  
- Circuit Diagrams

**XL**

Image helps you quickly identify product sections.



**Information List**

Each product section has its own "Table of Contents" to keep things simple.

The "Info List" is the first page of each product section.

**XL Information List (2002 - 2003)**

Wiring Diagram .....	6-2
Circuit Diagrams	
Starter Motor Circuit .....	6-3
Spark Circuit .....	6-3 - 6-6
Charging Circuit .....	6-6
Light Circuit .....	6-6

## GLOSSARY

The description is the name given to the part in the book only.

### Table of Contents

DESCRIPTION	PAGE
Clutch, Electric (PTO) .....	3 - 3
Gauge, Fuel .....	3 - 4
Gauge, Voltmeter .....	3 - 5
Hourmeter .....	3 - 6
Magnet Assembly - Cruise Control .....	3 - 7
Microswitches .....	3 - 7
KeyChoice™ Reverse Operating System .....	3 - 8
Module, KeyChoice™ Reverse Operating System (Electric PTO Clutch) .....	3 - 9
Module, KeyChoice™ Reverse Operating System (Manual PTO Clutch) .....	3 - 11
Module, Low Voltage .....	3 - 10
Relay .....	3 - 12
Sender, Fuel (P/N 94-1716) .....	3 - 13
Sender, Fuel (P/N 95-3971) .....	3 - 14
Solenoid .....	3 - 14
Switch, Brake .....	3 - 15
Switch, Cruise Control (P/N 93-0527 and P/N 94-7602) .....	3 - 16
Switch, Key (P/N 88-9830 or 104-2541) .....	3 - 17
Switch, Key (P/N 99-7429) .....	3 - 18
Switch, Key (P/N 92-6785) .....	3 - 19
Switch, KeyChoice™ Reverse Operating System .....	3 - 20
Switch, Light .....	3 - 21
Switch, Neutral .....	3 - 22
Switch, Neutral - Plunger Type .....	3 - 22

This is the most recent part number available at press time.



**2002 - 2003**

**XL**

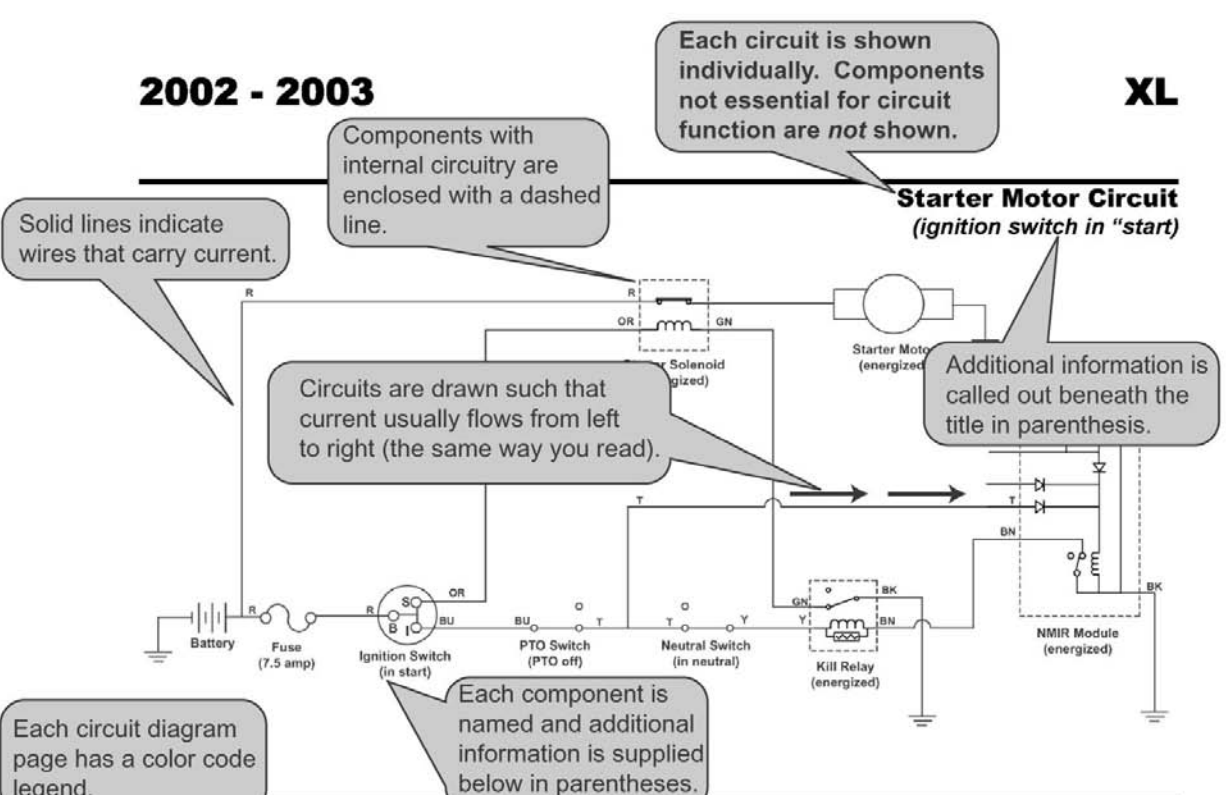

Legend	
Black	Bk
Blue	Bu
Brown	Bn
Green	Gn
Grey	Gy
Orange	Or
Pink	Pk
Red	Re
Tan	T
Violet	Vio
White	W
Yellow	Y

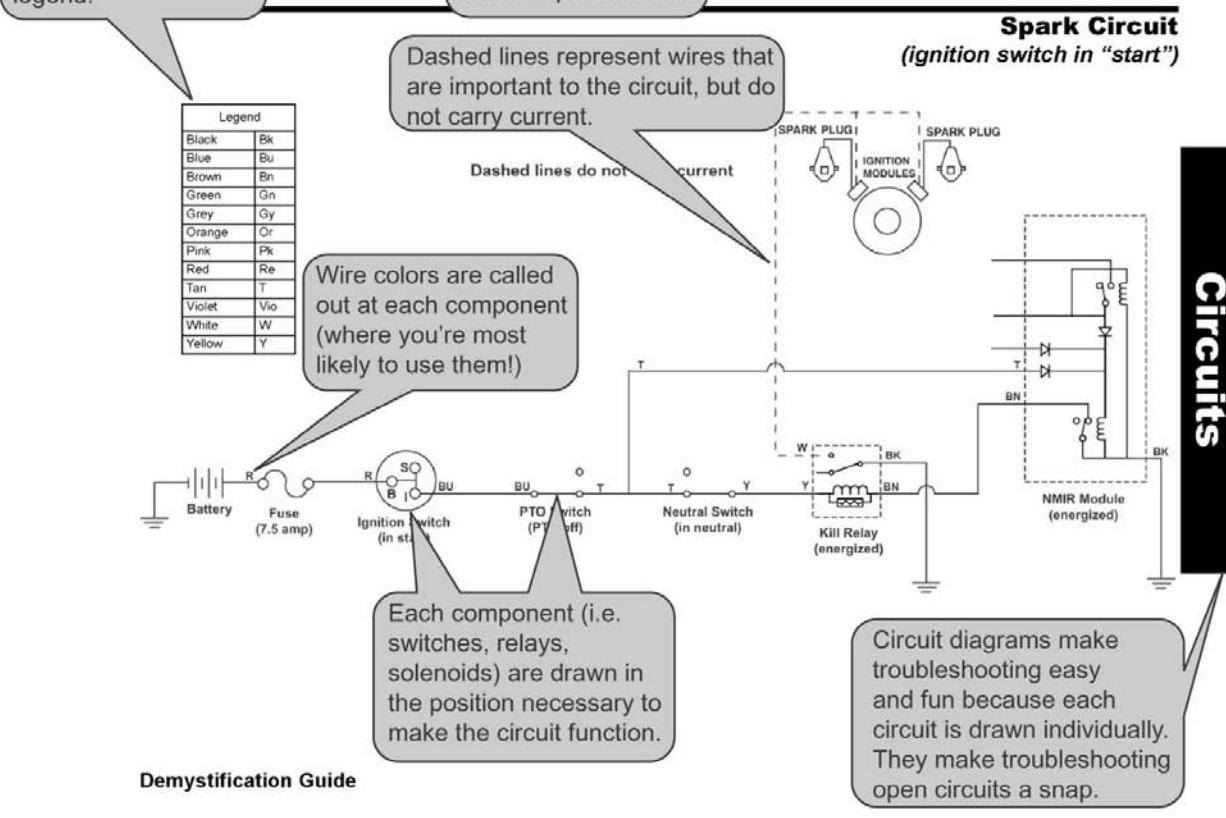

Demystification Guide

**Circuits**

## 1

### Checking Voltage

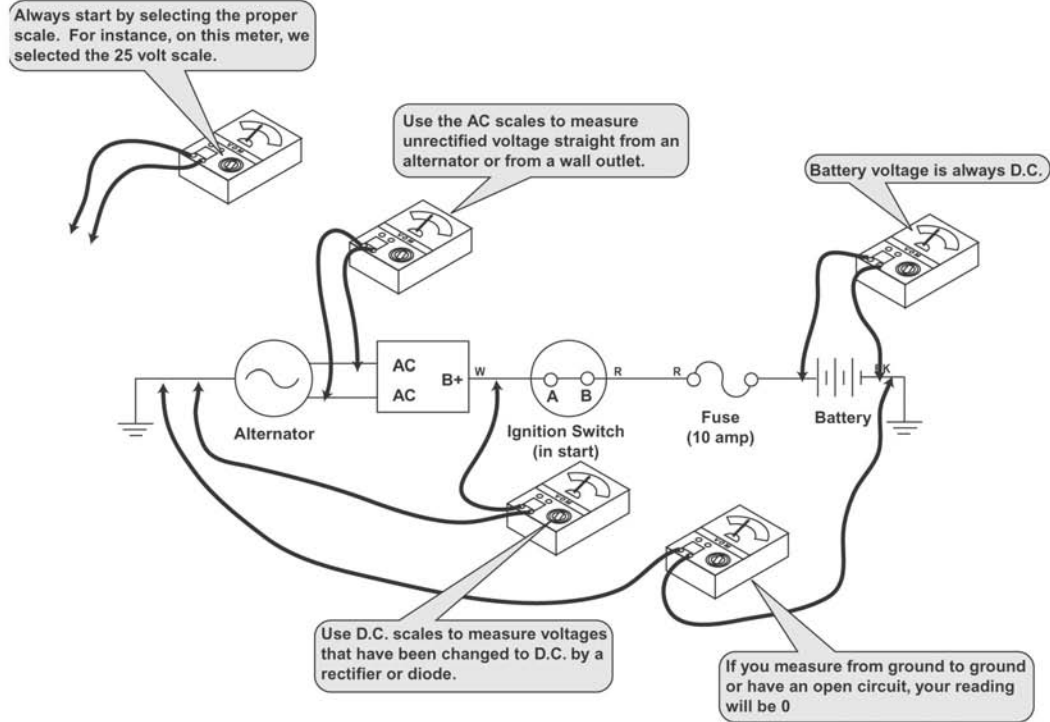

## 2

### Checking Resistance

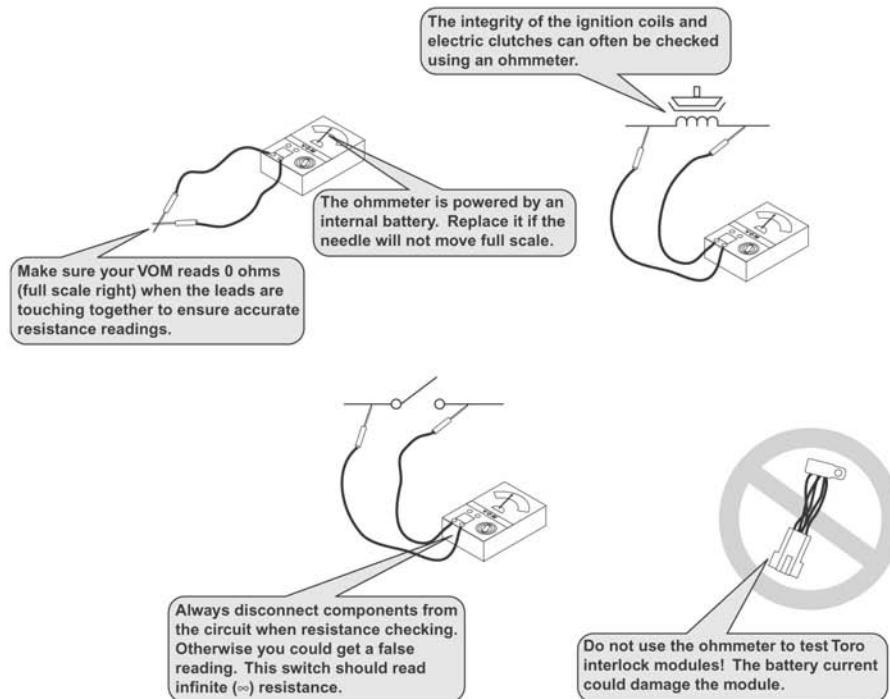

Using a VOM

# TIME SAVERS

## 3

### What about checking current?

Using a VOM

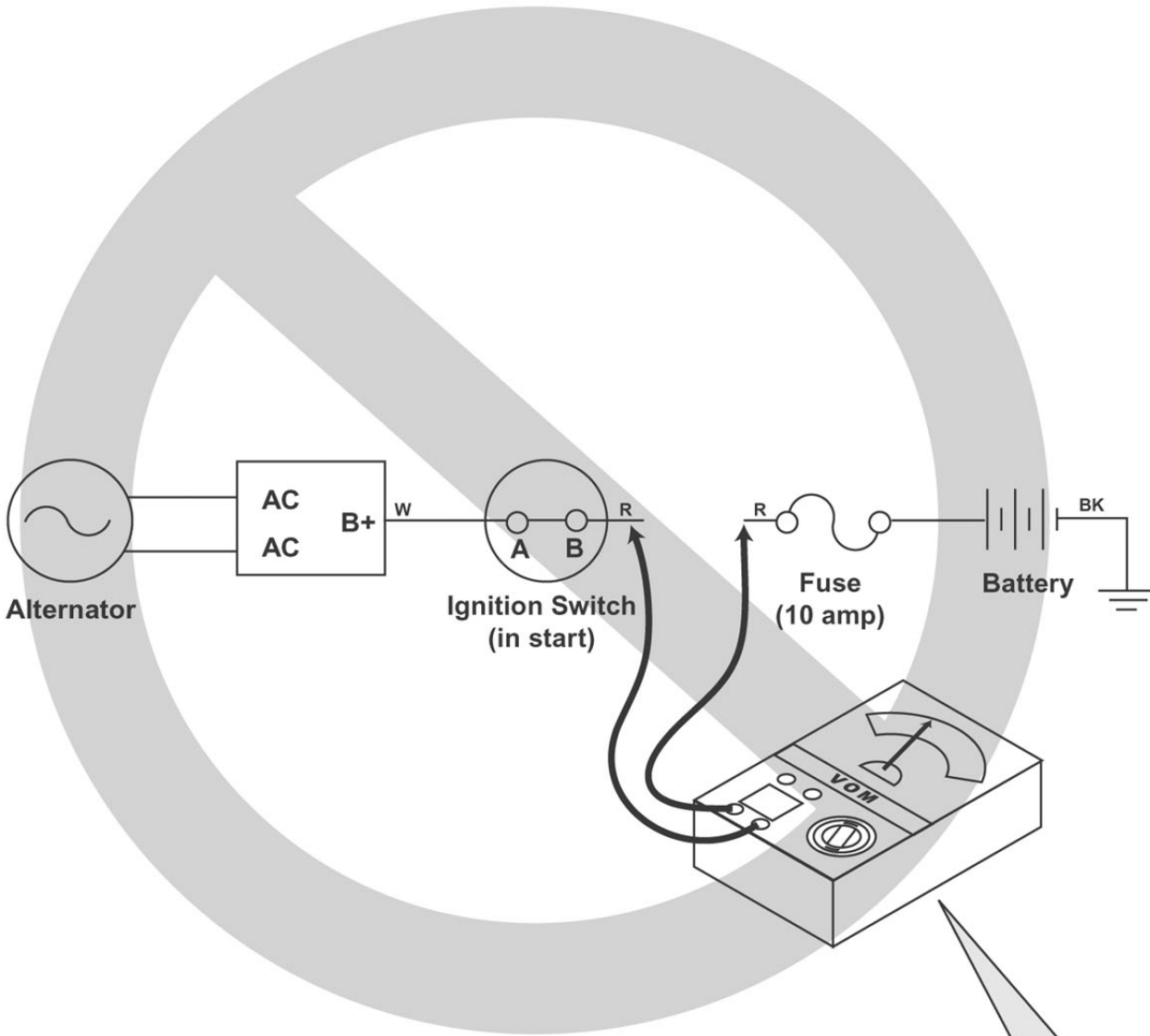

Many ammeters can measure only .1 amp. The current in Toro riding products generally is from 3-90 amps. Make sure your VOM can measure these higher currents.

## Sample Problem: 266-H electric clutch will not engage

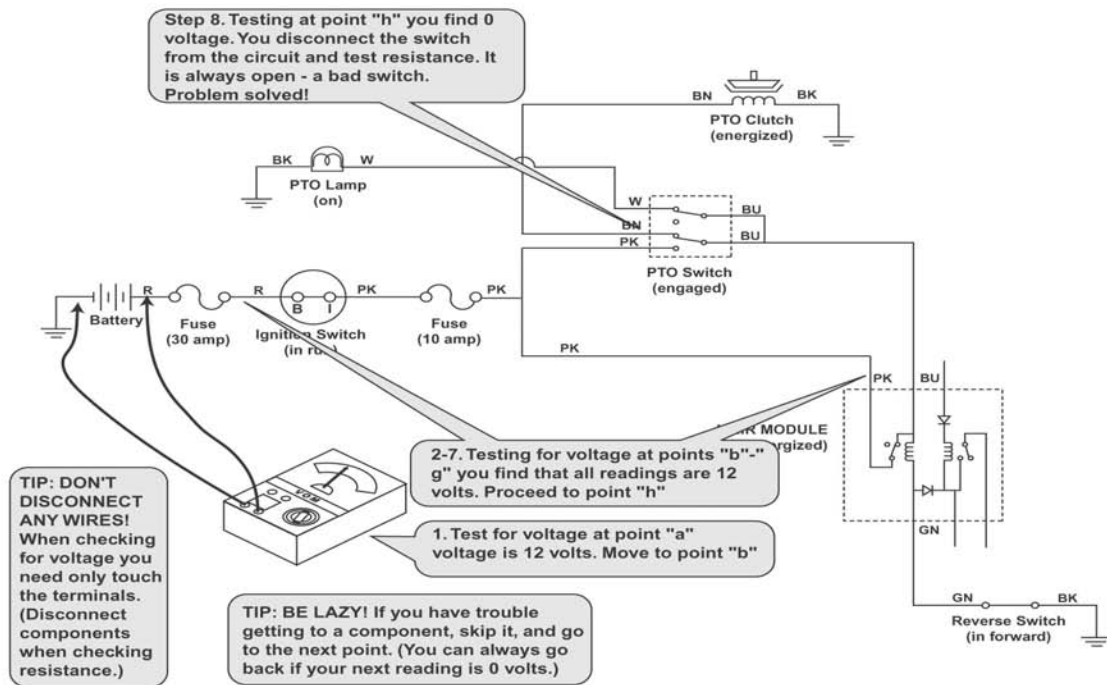

## Same Sample Problem: 266-H electric clutch will not engage (this time)

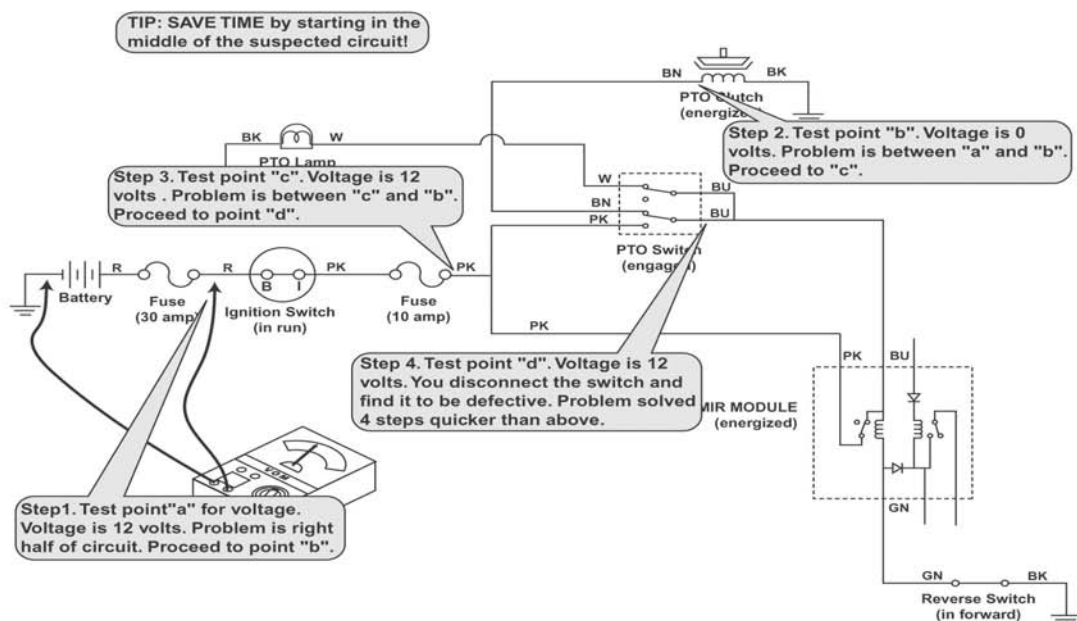

# TIME SAVERS

**Sample Problem:** This XL lawn tractor won't turn over. The customer parked it in the garage and turned it off. When he tried to start it a week later, he heard one click. After that, nothing would happen when he turned the key.

We know it is a short circuit because we found the 10 amp fuse blown.

## XL LAWN TRACTORS 2002

**Step 1. Interview the customer. Any information we get will help isolate the problem.**

**Step 2. Isolate the suspect area. Notice what we did to the wiring diagram below.**

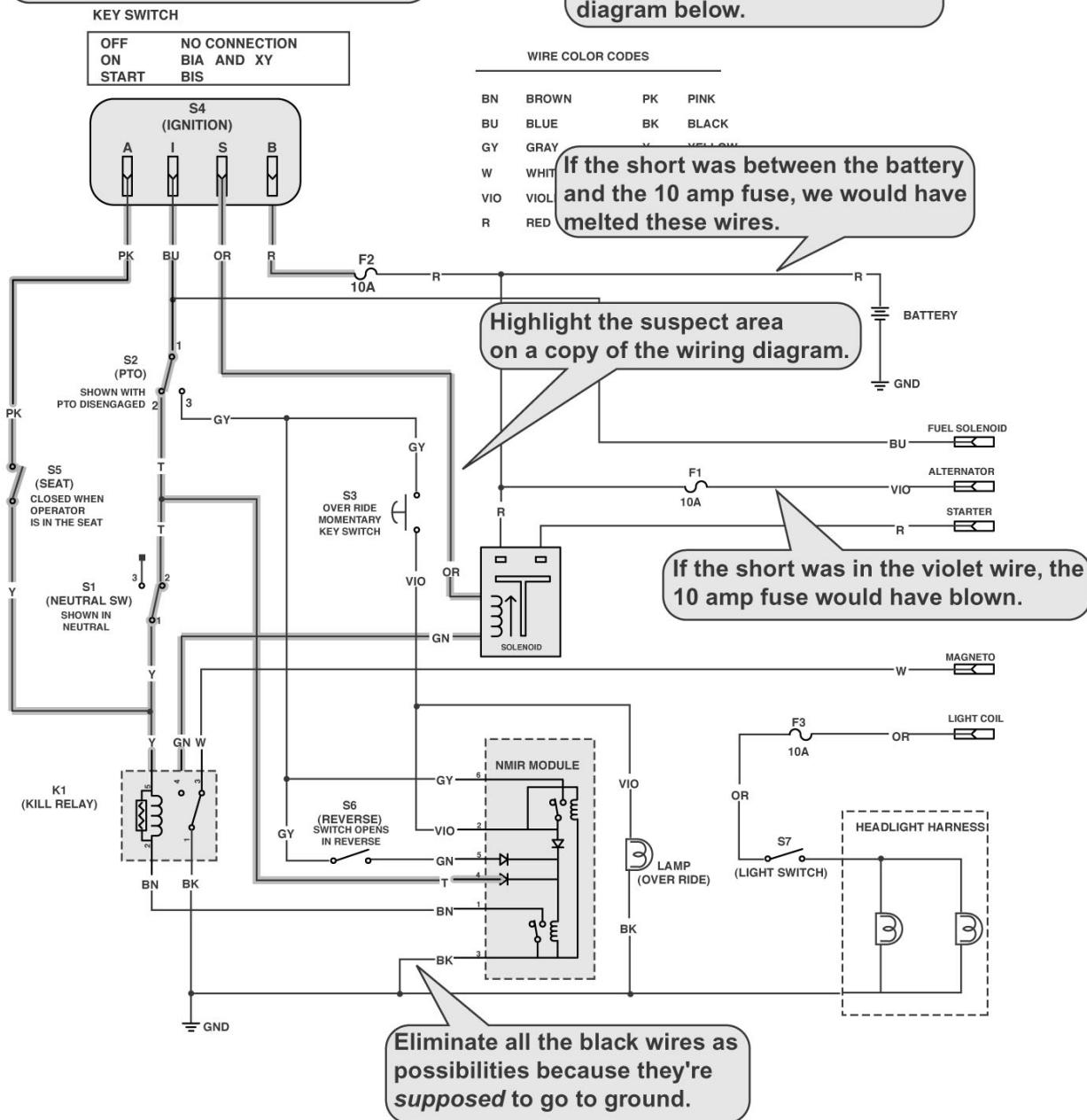



Step 3. Break the suspect area down into "mini-circuits". Do this by removing the unblown fuses and by opening all switches.

XL LAWN TRACTORS 2002

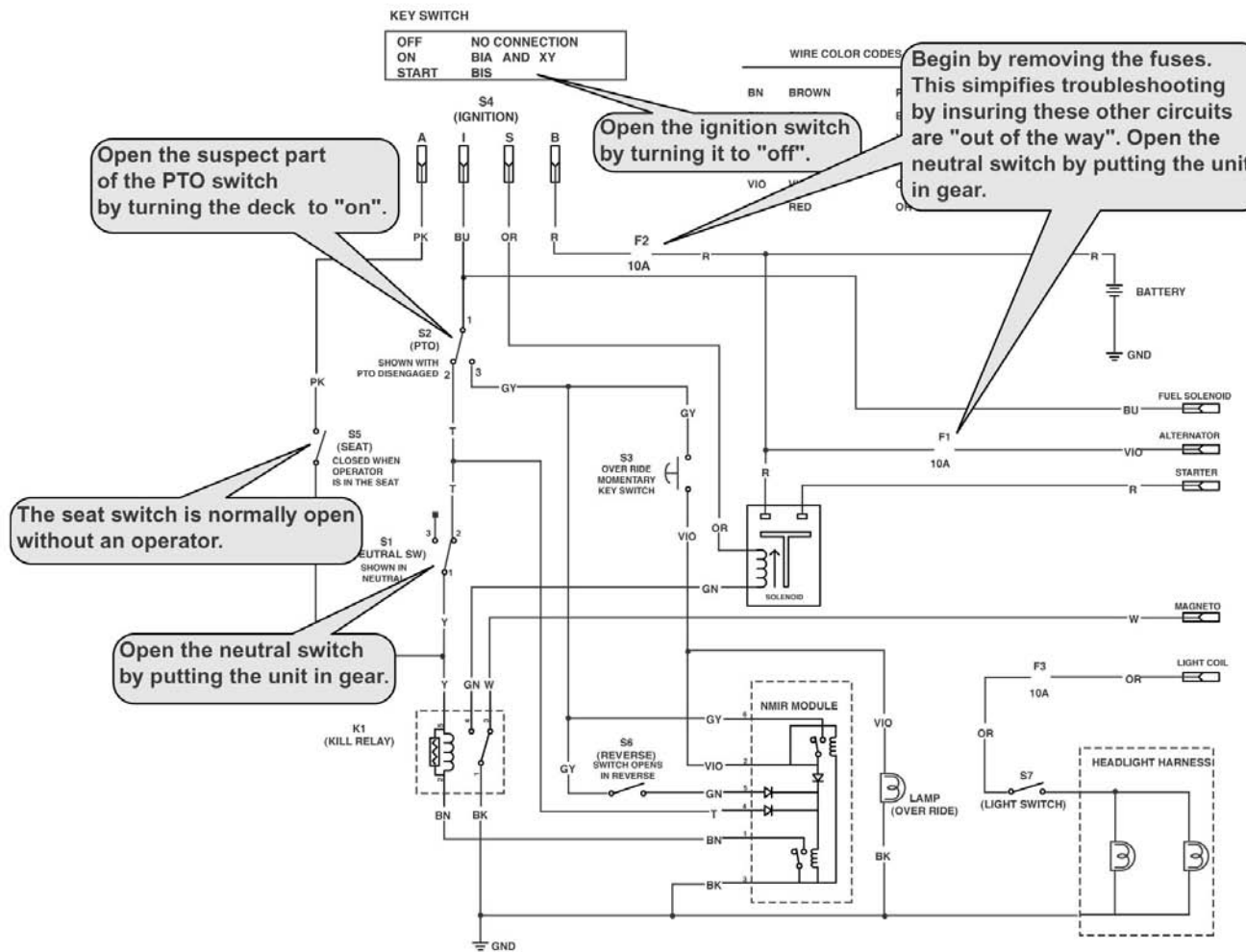

# TIME SAVERS

When the ignition switch is turned to "on", the 10 amp fuse doesn't blow. This means the blue and gray wires are OK.

Step 4. Power up one "mini-circuit" at a time, beginning with the one closest to the battery. 2002

Next, turn the ignition switch to "start". This "powers up" the orange and green wires. The fuse doesn't blow so these wires are OK.

Install a new 10 amp fuse. This "powers up" the red wire to the ignition switch. The fuse doesn't blow, so this wire is OK.

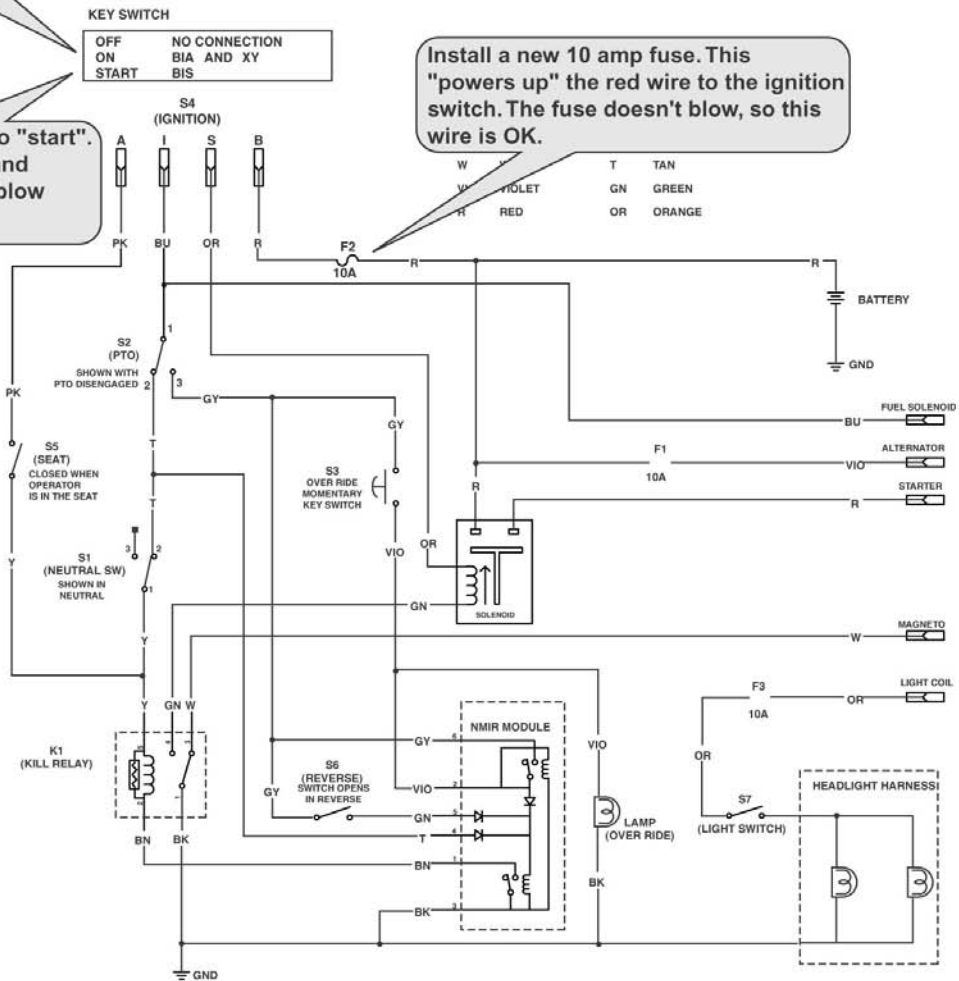



**This page intentionally left blank**

---

## Table of Contents

DESCRIPTION	PAGE
Clutch, Electric (PTO) . . . . .	3 - 3
Gauge, Fuel . . . . .	3 - 4
Gauge, Voltmeter . . . . .	3 - 5
Hourmeter . . . . .	3 - 6
Magnet Assembly - Cruise Control . . . . .	3 - 7
Microswitches . . . . .	3 - 7
KeyChoice™ Reverse Operating System . . . . .	3 - 8
Module, KeyChoice™ Reverse Operating System (Electric PTO Clutch) . . . . .	3 - 9
Module, KeyChoice™ Reverse Operating System (Manual PTO Clutch) . . . . .	3 - 11
Module, Low Voltage . . . . .	3 - 10
Relay . . . . .	3 - 12
Sender, Fuel (P/N 94-1716). . . . .	3 - 13
Sender, Fuel (P/N 95-3971). . . . .	3 - 14
Solenoid . . . . .	3 - 14
Switch, Brake . . . . .	3 - 15
Switch, Cruise Control (P/N 93-0527 and P/N 94-7602) . . . . .	3 - 16
Switch, Key (P/N 88-9830 or 104-2541) . . . . .	3 - 17
Switch, Key (P/N 99-7429). . . . .	3 - 18
Switch, Key (P/N 92-6785). . . . .	3 - 19
Switch, KeyChoice™ Reverse Operating System . . . . .	3 - 20
Switch, Light . . . . .	3 - 21
Switch, Neutral . . . . .	3 - 22
Switch, Neutral - Plunger Type . . . . .	3 - 22

# GLOSSARY

---

## Table of Contents

DESCRIPTION	PAGE
Switch, Neutral Adjustable - Plunger Type . . . . .	3 - 23
Switch, PTO . . . . .	3 - 24
Switch, Reverse . . . . .	3 - 25
Switch, Seat . . . . .	3 - 25

## Clutch, Electric (PTO)

### Purpose

This clutch electrically controls the engagement and disengagement of the Power Take Off (PTO) pulley.

### How It Works

The PTO clutch is composed of three major components; the field, the clutch plate, and the friction plate. The clutch plate always turns with the engine. The field is a coil of wire on an iron core, which becomes an electromagnet when power is applied. The friction plate can slide up and down on the crankshaft axis. It is normally spring loaded so that it is not in contact with the clutch plate and is pressed against the brake material opposite the clutch. When power is applied, the friction plate is drawn toward the clutch plate and the two rotate as one.

### Testing

If the electric PTO clutch is not engaging or is suspected as a cause of electrical problems, use the troubleshooting steps. These procedures will help you determine if the clutch has failed or is the cause of the electrical problem.

### Coil Resistance Measurement

1. Disengage the PTO, set the parking brake, turn the ignition key to **OFF** and remove the key.
2. Disconnect clutch wire connector.
3. Set the multimeter or volt/ohm meter to check resistance (ohms).

4. Connect the meter lead wires to the wires in the clutch connector (Figure 1).

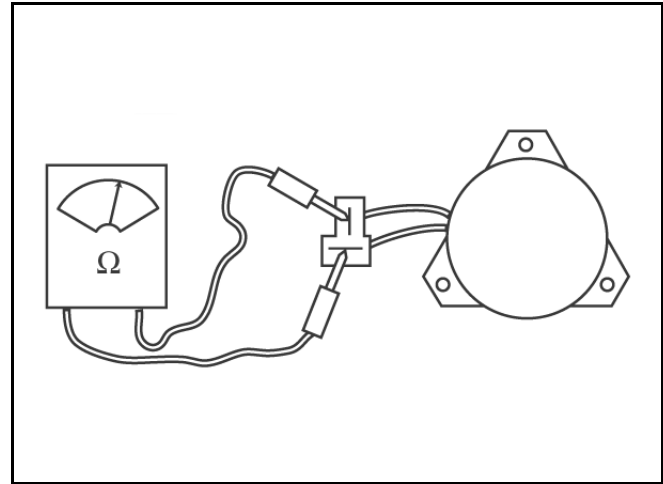

Figure 1

3-6

5. The meter should read between 2.40 ohms and 3.40 ohms. If the reading is above or below these readings, the field has failed and needs to be replaced. If the reading is between these two limits, measure the clutch current draw.

### Measuring Clutch Current Draw

1. Disengage the PTO, set the parking brake, and turn the ignition to **OFF**.
2. Disconnect the clutch wire connector.
3. Set the multimeter to check amps (10 amp scale).
4. Connect the positive meter lead to the tractor terminal (1) of the clutch wire, Figure 2.
5. Connect the negative meter lead to the corresponding wire terminal (3), Figure 2.
6. Connect a short jumper lead from terminal (2) to (4), Figure 2.
7. Turn the ignition switch to the "RUN" position and the PTO switch to the "ON" position.

# GLOSSARY

- If the meter reading is 3.5 amps or above, the system is functioning properly. If the meter reading is below 3.5 amps, check the electrical system for problems (i.e., the battery, ignition switch, PTO switch, or wiring harness may be malfunctioning).

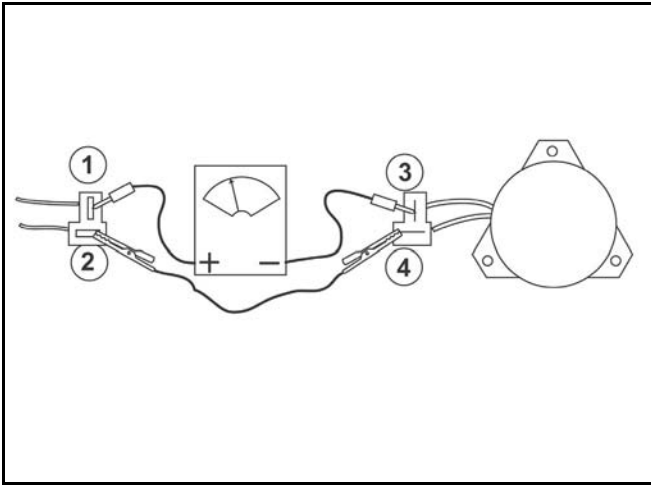

Figure 2

3-7

## Clutch Burnishing Procedure

The clutch should be burnished as part of the pre-delivery service, or whenever a new clutch is installed. Burnishing polishes the clutch plate, allowing for smooth clutch engagement.

With a PTO driven attachment installed (i.e., mower, snowthrower, or tiller), run the engine at half throttle. Engage and disengage the clutch 5 times (10 seconds on/10 off).

Increase engine RPM to  $\frac{3}{4}$  to full throttle. Engage and disengage clutch 5 times (10 seconds on/10 seconds off). Check and adjust the PTO clutch air gap (not required on 2000 and later models).

## Gauge, Fuel



Figure 3

mvc-104

### Purpose

This gauge indicates fuel level (Figure 3).

### How it Works

The meter movement moves in proportion to the amount of resistance provided by the fuel level sender in the tank. The movement is dampened to compensate for movement of the fuel in the tank.

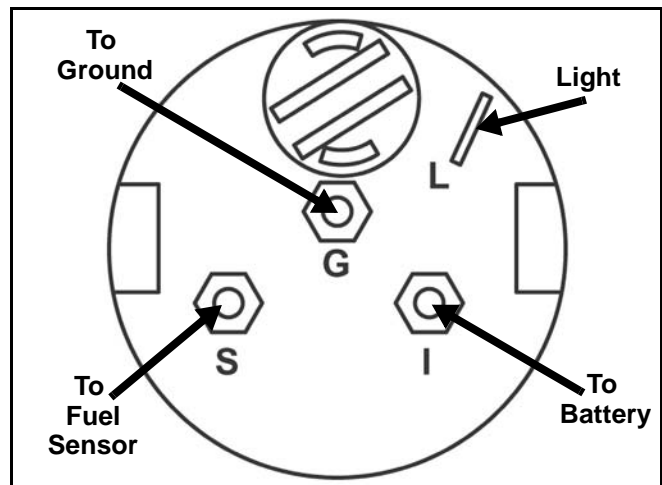

Figure 4

mvc-149



## Testing

1. With the gauge still connected to the harness, turn the key to the "RUN" position.
2. Using a VOM, set scale capable of reading 12 volts D.C., connect the negative lead to ground (Figure 4) to verify the conditions in the table below.

Terminal	Reading
G	0 volts
I	12 volts*
S	2.5 volts tank full
S	7.5 volts tank empty

\* All voltage readings should be within 20%.

## Gauge, Voltmeter



Figure 5

mvc-106

### Purpose

This gauge indicates the voltage across the battery (Figure 5).

### How it Works

The meter movement moves proportional to the voltage level across the two terminals of the battery. This is accomplished by placing a resistor in parallel with the meter movement.

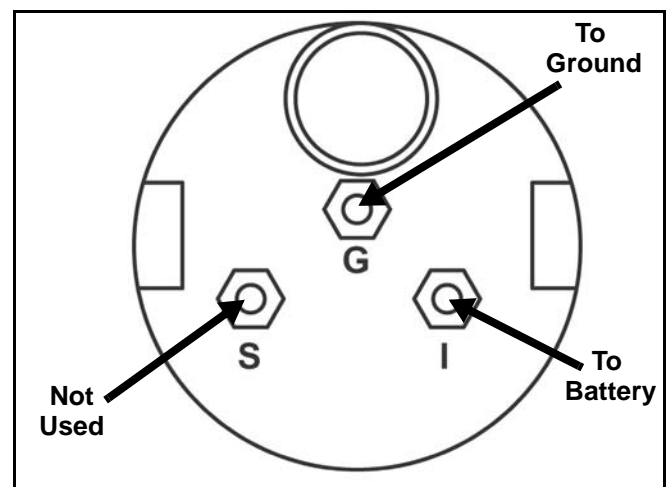

Figure 6

mvc-151

# GLOSSARY

## Testing

1. With the meter still connected to the harness, turn the key to the "RUN" position.
2. Verify the conditions in the table below. If they are not met, replace the voltmeter as it is not serviceable (Figure 6).

Terminal	Condition
I	12 volts DC +/- 20%
G	0 volts DC

## Hourmeter

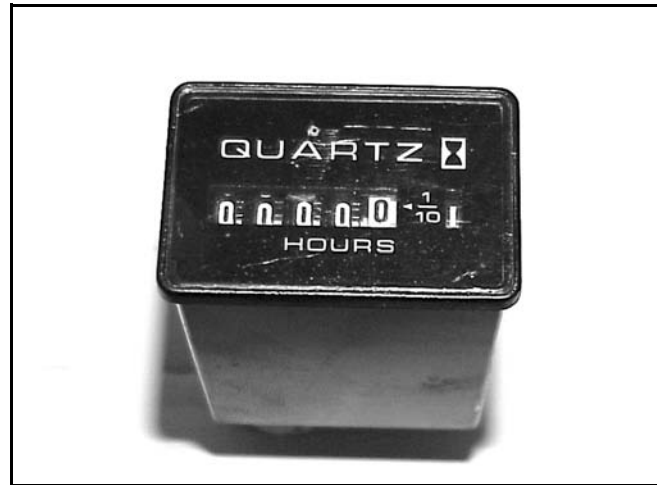

Figure 7

mvc-110

### Purpose

The hourmeter keeps track of the actual engine hours (Figure 7). This is accomplished by connecting the hourmeter to the engine oil pressure switch.

### How it Works

Since a normal clock might be affected by variations in voltage and current, the hourmeter is made up of a combination of an electric "winder" and a mechanical clock movement. When power is applied, a coil is energized to wind the movement. The movement unwinds in about two seconds. As it finishes its rotation, it re-energizes the coil so that the cycle can start over.

### Testing

Verify that 12 volts is present across the two terminals when the engine is running. If so, and the meter is not running, replace the meter. If 12 volts is not present, check the connections and the engine oil pressure switch. The meter is a permanently sealed unit and is not repairable.

## Magnet Assembly - Cruise Control



Figure 8

mvc-123

### Purpose

When engaging cruise control, the magnet assembly engages a cruise control plate that locks the control linkage to the speed that is set (Figure 8).

### How it Works

When the desired forward speed is obtained, push the cruise control switch on the dash. Through a cruise control relay, 12 volts is sent to the magnet assembly and this locks the magnet to the cruise control plate and locks the traction control. This allows you to remove your foot from the traction control.

### Testing

1. Unplug the wires and remove the magnet assembly from the tractor.
2. Place the magnet assembly on a metal surface and apply 12 volts D.C. positive and negative to the wire leads.
3. The magnet assembly should hold to the metal surface. When voltage is removed, the magnet assembly can be removed from the metal surface.

## Microswitches

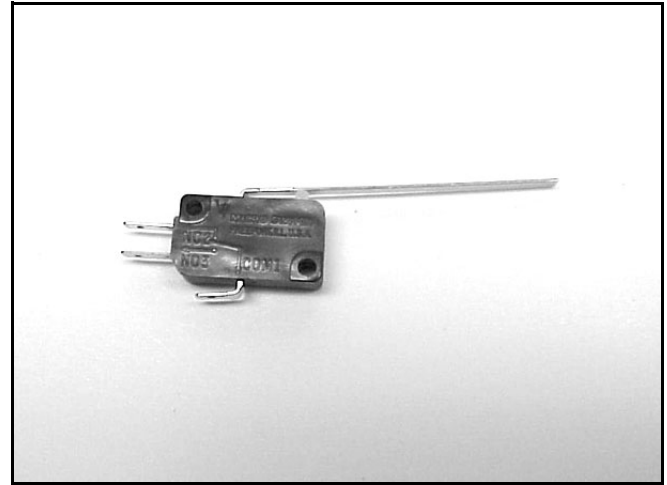

Figure 9

mvc-677X

### Purpose

Microswitches are used to monitor whether or not a lever or pedal is in the correct position (Figure 9).

### How It Works

This SPDT (Single Pole Double Throw) microswitch has three terminals. The lever is spring loaded in the “up” position. When the button is pushed down, continuity switches from COM and NC to COM and NO.

### Testing

1. Disconnect the switch from the harness.
2. Using an ohmmeter (ohm), connect one meter lead to the “COM” terminal, and other lead to the “NC” terminal.
3. With the switch in the spring loaded “up” position, there should be continuity; the switch is operating properly. Push the button “down”. There should be **no** continuity; the switch is operating properly.
4. Connect one meter lead to the “COM” terminal and the other lead to the “NO” terminal.
5. With the button in the “OUT” spring loaded position, if there is **no** continuity, the switch is operating properly.
6. Then move the switch button to the “down” position. If there is continuity, the switch is operating properly.

# GLOSSARY

## KeyChoice™ Reverse Operating System

This interlock feature is provided to prevent unintentional engine-powered attachment operation in reverse. If the tractor is shifted into reverse while the mower blade or other Power Take Off (PTO) driven attachment is engaged, the electric clutch will disengage or the engine will stop, depending on the model. **DO NOT MOW WHILE BACKING UP UNLESS ABSOLUTELY NECESSARY.** If you need to mow while in reverse or use other PTO drive attachments (such as a snowthrower), this interlock feature may be temporarily deactivated.

Before deactivating this feature, be sure there are no children present on or near property where you are using the tractor and that are likely to appear while you are mowing or operating an attachment. Be extra observant after you have chosen to deactivate the interlock feature because the sound of the tractor's engine might prevent you from being aware that a child or bystander has entered the area where you are operating the tractor.

Once you are sure you can safely mow in reverse or operate an attachment, deactivate the reverse operating system by turning the KeyChoice™ switch, located around the seat area, after engaging the PTO system. A red light will illuminate on the dash as a reminder that the reverse operating system interlock has been deactivated. Once the interlock is deactivated, it stays in this mode **WITH YOUR MOWER BLADE OR ATTACHMENT OPERATING WHENEVER YOU BACK-UP**, and the dash light stays on until either the PTO clutch is disengaged or the engine is turned off.

### Systems:

There are two different "shutdown" systems used in the KeyChoice™ Reverse Operating System. One system is used with the electric (PTO) clutch - when the tractor is shifted to reverse while the mower blade or other PTO driven attachment is engaged the electric clutch will disengage. The other system is used with the manual (PTO) clutch - when the tractor is shifted to reverse while the mower blade or other PTO driven attachment is engaged, the engine will stop.

## Testing the KeyChoice™ Reverse Operating System - Electric PTO System - Unactivated

1. With the parking brake released, seat occupied, turn the ignition key to "RUN" without starting the engine.
2. Pull the PTO electric clutch switch "ON".
3. You should hear an audible click, indicating the PTO is activated and the PTO light will come on.
4. Move the forward/reverse pedal to reverse. On the gear drive tractors, shift the gear selector to reverse.
5. You should hear an audible click indicating the PTO is deactivated and the PTO light, on the dash, should turn off.

## Testing the KeyChoice™ Reverse Operating System - Electric PTO System - Activated

1. With the parking brake released, seat occupied, turn the ignition switch to "RUN" without starting the engine.
2. Pull the PTO electric clutch switch to "ON".
3. Turn the "KeyChoice" key and release.
4. The "KeyChoice" warning light on the dash should come on.
5. Move the foot pedal to reverse. On the gear drive model tractors, move the gear selector to reverse.
6. The PTO and "KeyChoice" warning lights on the dash should remain on.
7. Push the PTO switch to "OFF".
8. The PTO light and the "KeyChoice" warning lights should turn off.

## Testing the KeyChoice™ Reverse Operating System - Manual PTO System - Unactivated

1. Move the Power Take Off (PTO) lever to the "disengage" position and move the gear shift lever to neutral on the gear shift model tractors. Depress the clutch/brake pedal.
2. Now start the engine.

3. While the engine is running, move the PTO lever to the “engage” position, on gear shift models, move the gear shift lever in reverse, and on Hydro models, move the forward/reverse pedal to reverse.
4. The engine should stop.

### Testing the KeyChoice™ Reverse Operating System - Manual PTO System - Activated

1. Move the PTO lever to the “disengage” position and move the gear shift lever to neutral on gear shift models. Depress the clutch/brake pedal on the Hydro’s.
2. Now start the engine.
3. Move the PTO lever to the “engage” position and turn the KeyChoice™ key, located around the seat area.
4. A red light on the dash turns on, indicating the interlock (Reverse Operating System) is disabled.
5. You should be able to operate the machine in reverse and the engine/mower will continue to run.
6. Move the PTO lever to the “disengage” position and the red light should turn off on the dash.

## Module, KeyChoice™ Reverse Operating System (Electric PTO Clutch)

### Purpose

The KeyChoice™ Reverse Operating System Module (Figure 10) works with the KeyChoice™ switch, PTO switch, and the reverse switch. It responds to the reverse switch. If the override switch (KeyChoice™ switch) is not activated and the PTO is engaged, it will stop the electric PTO clutch.

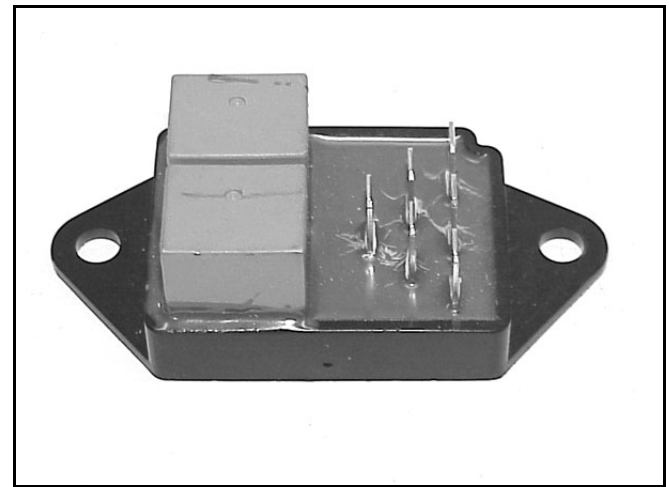

Figure 10

MVC-385X

### How It Works

The KeyChoice™ Reverse Operating System Module is made up of several components, such as diodes and relays. When it is connected in the circuit, voltage is applied to certain terminals of the KeyChoice™ Reverse Operating System module from the PTO switch, reverse switch, and the override switch, which energizes certain relays in the module. If voltage is not applied to proper terminals on the KeyChoice™ Reverse Operating System Module, the electric PTO clutch will stop.

# GLOSSARY

## Testing

The KeyChoice™ Reverse Operating System Module must be removed from the wiring harness. Using a multimeter check the following (Figure 11):

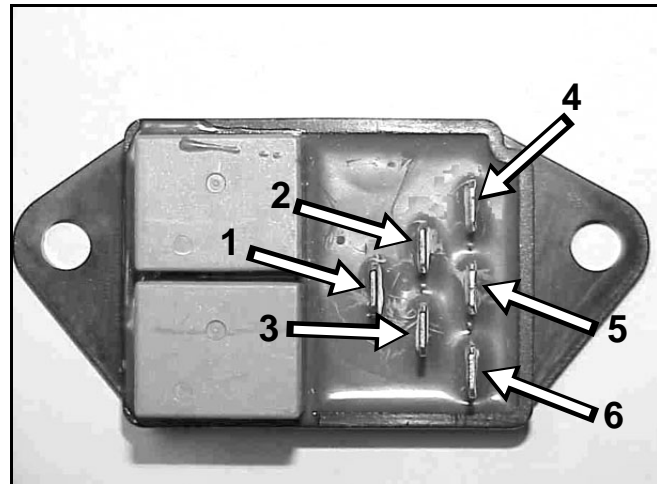

Figure 11

NMIR Module

### Testing - No Power To Circuit (With Module Out of Circuit)

Meter Scale	Meter Probe Negative	Meter Probe Positive	Meter Reading
Ohms	Pin 3	Pin 5	Open (More than 100K ohms)
Diode*	Pin 3	Pin 6	.5 to 1 Volt
Diode*	Pin 3	Pin 1	.5 to 1 Volt
Diode*	Pin 3	Pin 4	.5 to 1 Volt
Ohms	Pin 1	Pin 4	350 to 400 ohms
Ohms	Pin 2	Pin 4	Open (more the 100K ohms)

\*Note: If the multimeter does not have a diode test feature, this test can not be performed. This is not a problem if powered tests are done. Powered tests must be performed to test relays (see table below).

### Testing - Powered Circuit (With Module Out of Circuit)

Meter Scale	Volt Meter		Battery		Meter Reading
	Neg Probe	Pos Probe	Neg Lead	Pos Lead	
Ohms	Pin 2	Pin 5	Pin 3	Pin 6	< 10 Ohms
Volts (Caution)	Pin 1	Pin 2	Pin 1	Pin 4	12 Volts***
Volts (Caution)	Pin 3	Pin 2	Pin 3	Pin 4	12 Volts***

\*\*\* Same as battery voltage

**Note:** A 12 volt battery is needed for this test. **USE CAUTION WHEN MEASURING RESISTANCE WITH A POWERED CIRCUIT. CONTACTING A VOLTAGE SOURCE WITH A METER IN OHMS POSITION CAN SERIOUSLY DAMAGE THE METER.**

## Module, KeyChoice™ Reverse Operating System (Manual PTO Clutch)

### Purpose

The Key Choice™ Reverse Operating System module works with the KeyChoice™ switch, PTO switch, and the reverse switch. It responds to the reverse switch; if the override switch (KeyChoice™ switch) is not activated and the PTO is engaged, it will stop the engine (Figure 12).

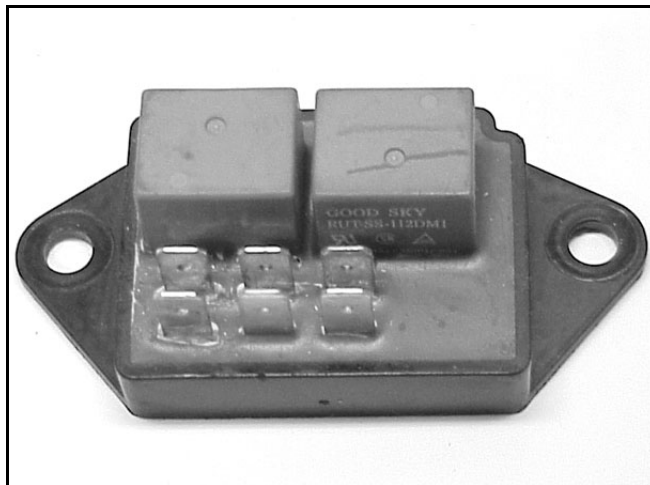

Figure 12 mvc-692

### How it Works

The Key Choice™ Reverse Operating System is made up of several components, such as diodes and relays. When it is connected in the circuit, voltage is applied to certain terminals of the Key Choice™ Reverse Operating System module from the PTO switch, reverse switch, and the override switch, which energizes certain relays in the module. If voltage is not applied to the proper terminals on the Key Choice™ Reverse Operating System module, the engine will stop.

### Testing

The Key Choice™ Reverse Operating System module must be removed from the circuit. Using a multimeter check the following:

Meter Scale	Meter Probe Negative	Meter Probe Positive	Meter Reading
Ohms	Pin 3	Pin 1	Open (more than 100k ohm)
Ohms	Pin 3	Pin 2	350 to 450 ohms
Diode	Pin 3	Pin 4	0.7V to 1.0V *
Diode	Pin 3	Pin 5	0.7V to 1.0V *
Ohms	Pin 3	Pin 6	Open (more than 100k ohms)

\* **NOTE:** If multimeter does not have a diode scale, this test can not be done. This is not a problem if powered tests are done. Powered test must be done to check out relays (Figure 13).

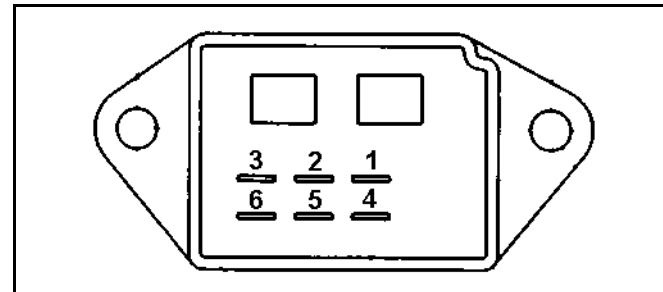

Figure 13

**Powered circuit test (with module out of circuit). A 12 volt battery is needed for this test. NOTE: USE CAUTION WHEN MEASURING RESISTANCE WITH A POWERED CIRCUIT. CONTACTING A VOLTAGE SOURCE WITH METER IN OHMS POSITION CAN SERIOUSLY DAMAGE THE METER.**

Ground	B+ (12V)	Meter Probe Neg.	Meter Probe Pos.	Meter Scale	Meter Reading
Pin 3	Pin 4	Pin 3	Pin 1	Ohms	<2 ohms
Pin 3	Pin 5	Pin 3	Pin 1	Ohms	<2 ohms
Pin 3	Pin 2	Pin 3	Pin 1	Ohms	<2 ohms
Pin 3	Pin 2	Pin 3	Pin 6	Volts	12 V **

\*\* **NOTE:** Actual reading should be same as B+ applied to Pin 2.

# GLOSSARY

## Module, Low Voltage

### Purpose

The illumination of the battery light on the dash indicates the battery voltage is too low. This is controlled by the low voltage module (Figure 14).

### How it works

The low voltage module is a voltage comparator, checking the charge voltage from the engine regulator/rectifier system. If the charge voltage is less than 11.3 volts D.C., the low voltage module senses this and activates the indicator lamp on the dash which will light until the voltage is over 12 volts D.C.

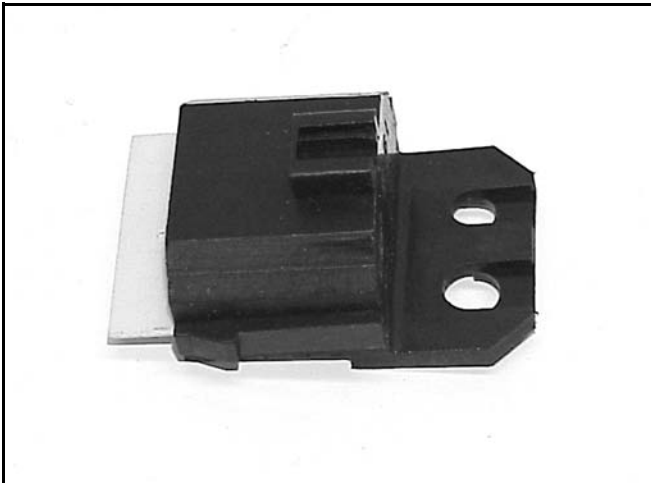

Figure 14

mvc-388

### Testing

1. Before replacing the low voltage module, test the battery to make sure it is fully charged and is in good shape.
2. Next, check the charging system of the engine; follow the procedure in the appropriate engine service manual.
3. If the battery checks out and is in good condition and the charging system checks out and is charging properly and the battery light on the dash is on, replace the low voltage module. Without specialized test equipment, it is not practical to test the low voltage module in the field.

## Relay

### Purpose

The relay is used in a variety of ways to turn circuits on and off.

### How It Works

A relay is an electrically actuated switch.

1. Coil: Terminals 85 and 86 are connected to a coil. Applying 12 volts to these terminals energizes the coil turning it into an electromagnet.
2. Switch: Terminals 30, 87, and 87a are actually part of a single pole, double throw (SPDT) switch. Terminal 30 is the common lead. The switch is spring loaded so that 30 and 87a are connected when the coil is not energized. When the coil is energized, the switch is "thrown" and 30 and 87 are connected (Figure 15).

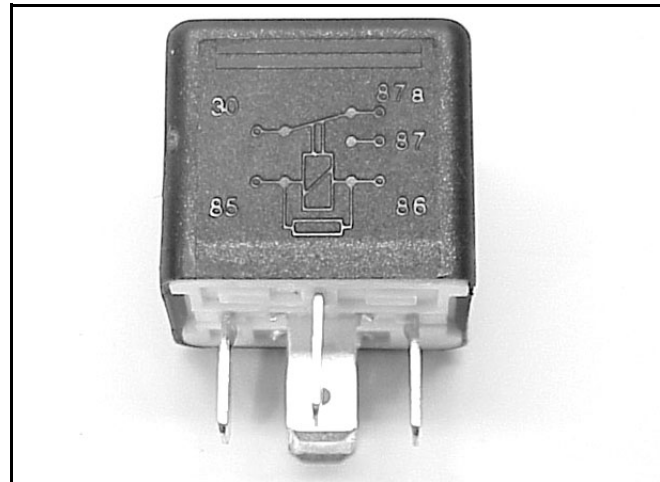

Figure 15

MVC-671

### Testing

1. Disconnect the relay from the harness.
2. Verify the coil resistance between terminals 85 and 86 with a multimeter (ohms setting). Resistance should be from 70 to 90 ohms. There should be continuity between terminals 87a and 30 (Figure 16).



3. Connect multimeter (ohms setting) leads to relay terminals 30 and 87. Ground terminal 86 and apply +12 VDC to terminal 85. The relay should make and break continuity between terminals 30 and 87 as 12 VDC is applied and removed from terminal 85 (Figure 16).
4. Connect multimeter (ohms setting) leads to relay terminals 30 and 87a. Apply +12 VDC to terminal 85. With terminal 86 still grounded, the relay should break and make continuity between terminals 30 and 87a as 12 VDC is applied and removed from terminal (Figure 16).
5. Disconnect voltage and multimeter leads from relay terminals.

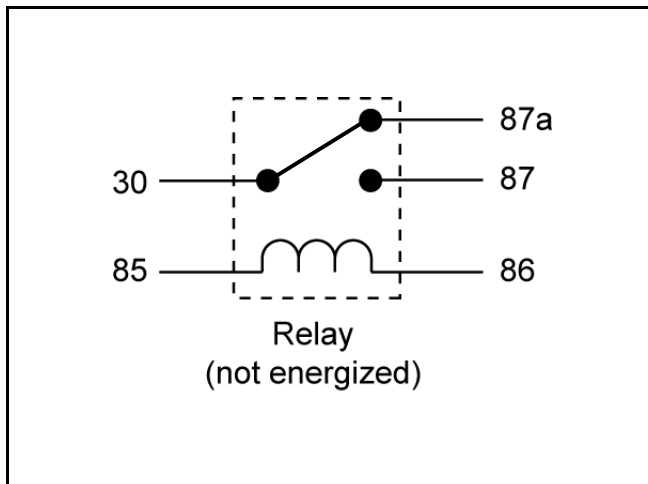

Figure 16

XL Relay

## Sender, Fuel

(P/N 94-1716)



Figure 17

MVC-121

### Purpose

This electrical component monitors the level of fuel in the tank (Figure 17).

### How it Works

Located at the bottom of the fuel sender is a float. When fuel runs low in the fuel tank, the float should drop. When it reaches a certain point, the sensor's contacts close and the low fuel light, located on the dash, lights up.

### Testing

1. Disconnect the fuel sender from the wiring harness and remove from the fuel tank.
2. With a VOM set for continuity, connect to the two wire leads, hold the fuel sender upright, float in down position, and the wiring facing the top. You should have continuity.
3. Turn the fuel sender upside down, with the float up and the wires down. You should have NO continuity.

# GLOSSARY

## Sender, Fuel

(P/N 95-3971)

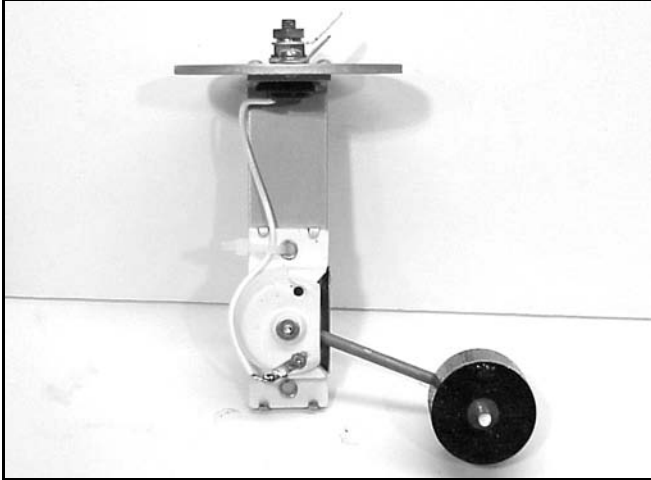

Figure 18

mvc-118

### Purpose

This electrical component monitors the level of fuel in the tank (Figure 18).

### How it Works

A float is attached to a pivoting lever. This lever rotates a potentiometer (a device much like the volume control on your stereo) to vary resistance. The resistance will be 25 to 200 ohms, plus or minus 20%.

### Testing

1. Before removing the unit, verify that the float has not sunk. Replace the float if it is sunk.
2. Disconnect the sender unit from the wiring harness and remove from the gas tank.
3. Verify that it matches the resistance in the following table.

Float Position	Resistance
Full	25 ohms +/- 20%
Empty	200 ohms +/- 20%

## Solenoid

### Purpose

The solenoid's purpose is simply to connect the battery to the starter motor when the ignition switch is turned to "START". The solenoid is used to protect the ignition switch from the high current drawn by the starter motor.

### How it Works

The solenoid has two primary parts. One is a coil of wire wrapped around an iron core. Whenever 12 volts is applied to the coil, it becomes a magnet. The other part is a bar type switch (Figure 19). Because it has a large contact area with the contact terminals it can easily handle the high current loads required by the starter motor.

When 12 volts is applied to the coil, it becomes an electromagnet. This quickly pulls the bar toward contacts and closes the switch. When power is removed from the coil, the spring loaded bar returns to its "normally open" position. The solenoid closes and opens the switch very quickly. This minimizes the "arcing" that can damage other types of switches.

The ignition switch is protected because only a small amount of current is needed to activate the coil.

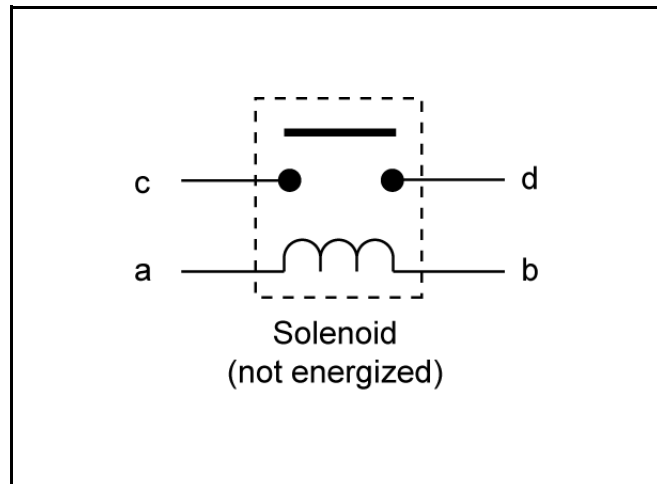

Figure 19

XL Solenoid

## Testing

1. Disconnect the solenoid from the wiring harness.
2. With a multimeter (ohms setting), check to ensure that terminals “c” and “d” are open (no continuity) (Figure 19).
3. Apply +12 VDC to terminal “a” and ground terminal “b”. Terminals “c” and “d” should now be closed (continuity) (Figure 19).
4. You should be able to hear the solenoid switch “click” when you make the connection.

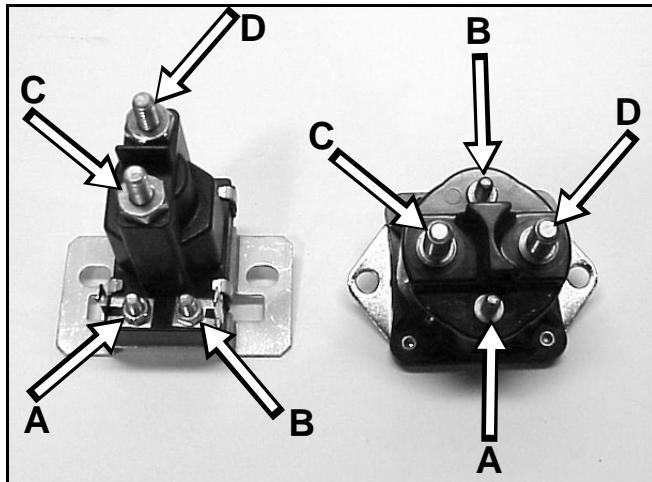

Figure 20 mvc-675

(A) & (B) Coil Terminals	(C) & (D) Contact Terminals
--------------------------	-----------------------------

## Switch, Brake

### Purpose

This double pole plunger type switch has four terminals. When the brake pedal is depressed, it completes the safety circuit for start. On tractors with cruise control, the cruise control circuit is connected to the brake switch. When the brake pedal is depressed, the switch opens and the cruise control magnet disengages.

### How it Works

This double pole plunger switch has four terminals. When the brake pedal is depressed, it pushes on the plunger, closing and opening the contacts in the switch.

### Testing

1. Disconnect the switch from the wiring harness.
2. Using a multimeter, follow the procedures listed below (Figure 21):

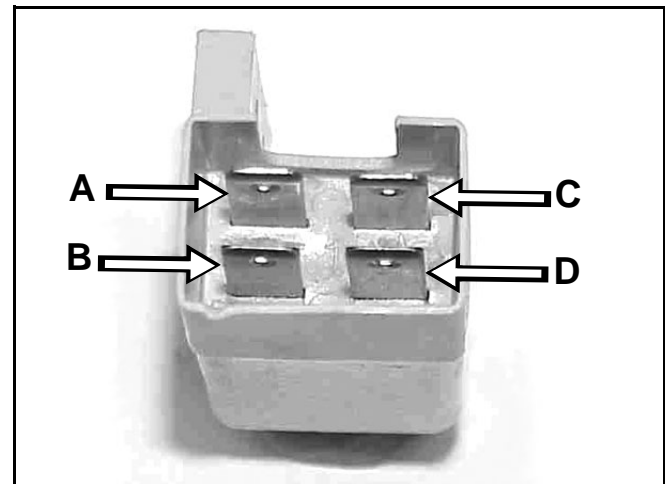

Figure 21 Brake Switch

Note: Terminals on actual switch not labeled.

Plunger <u>Not</u> Depressed	Plunger Depressed
A/B Terminals - Closed Circuit - Continuity	A/B Terminals - Open Circuit - No Continuity
C/D Terminals - Open Circuit - No Continuity	C/D Terminals - Closed Circuit - Continuity

# GLOSSARY

## Switch, Cruise Control

P/N 93-0527 and P/N 94-7602



P/N 93-0527

Figure 22

mvc-112



P/N 94-7602

Figure 23

mvc-114

### Purpose

This rocker switch is used to provide switching for the cruise control (Figure 22 and Figure 23).

### How it Works

The switch has contacts inside which connect two terminals in one position while disconnecting them in the other. There are 3 positions to the switch; OFF, START, and RUN. The start position is spring loaded so that the switch automatically returns to the "RUN" position.

### Testing

1. Disconnect the switch from the wiring harness.
2. Using a VOM or test lamp, test the continuity of the terminals using the following diagrams (Figure 24 and Figure 25).

P/N 93-0527

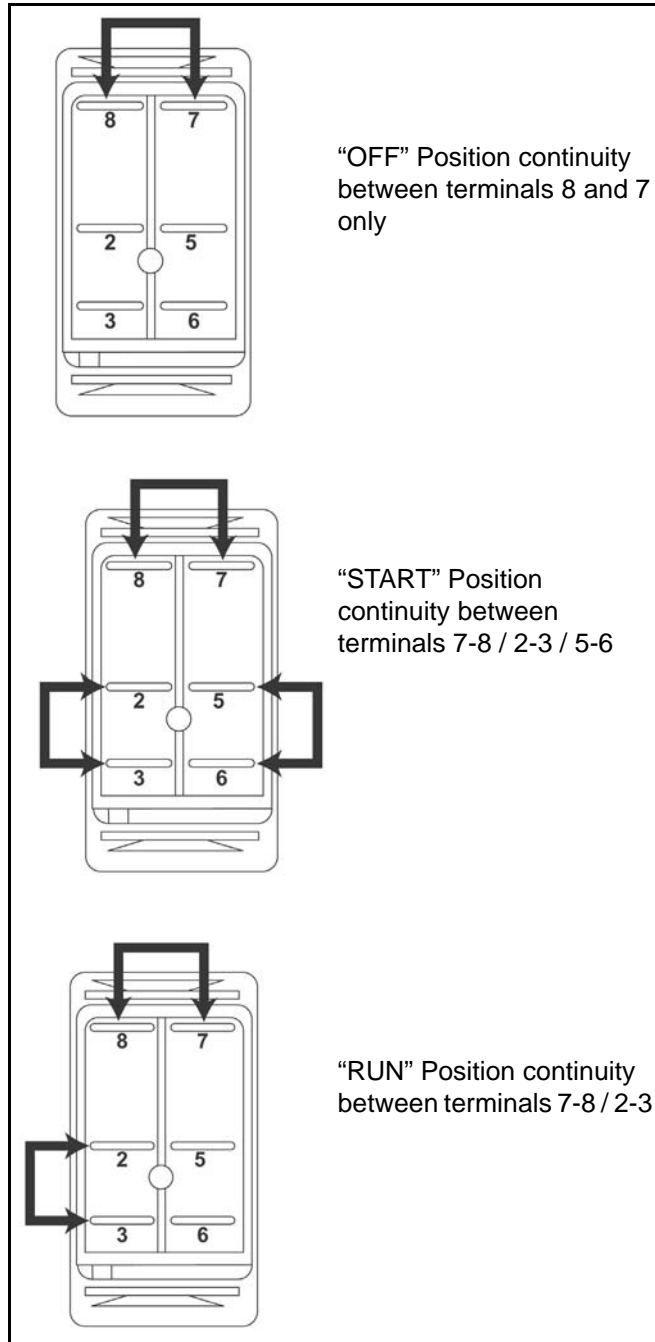

Figure 24

mvc-163art

P/N 94-7602

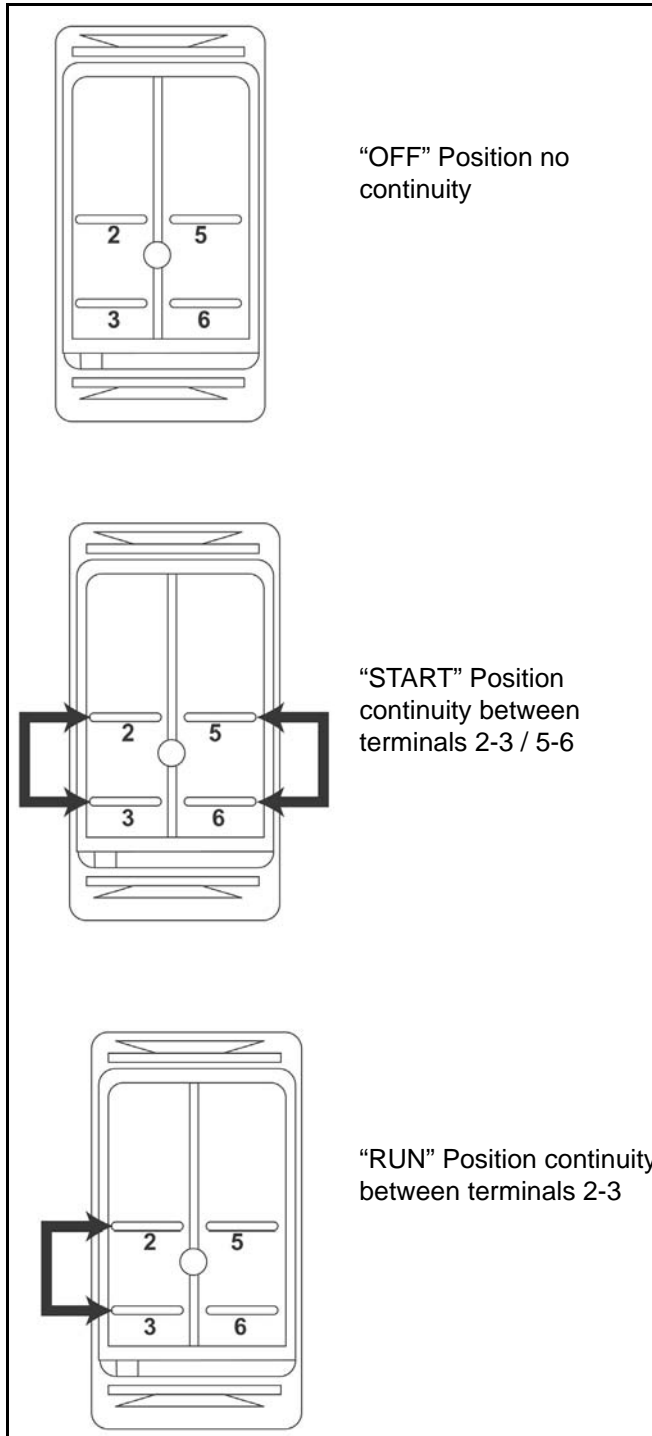

Figure 25

mvc-164art

## Switch, Key

(P/N 88-9830 or 104-2541)

### Purpose

This component provides the proper switching for the starter, ignition, accessories, and safety circuits (Figure 26).

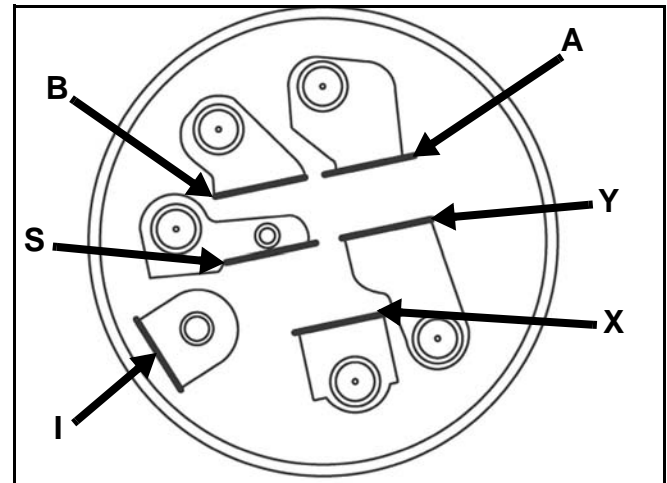

Figure 26

mvc-166art

### How it Works

Detents inside the switch give it 3 positions: OFF, RUN, and START. The START position is spring loaded so the cylinder automatically returns to RUN once the key is released.

# GLOSSARY

## Testing

1. Disconnect the switch from the wiring harness.
2. Verify that continuity exists between the terminals listed for the switch position. Verify that there is NO continuity between terminals not listed for the switch position (Figure 27).

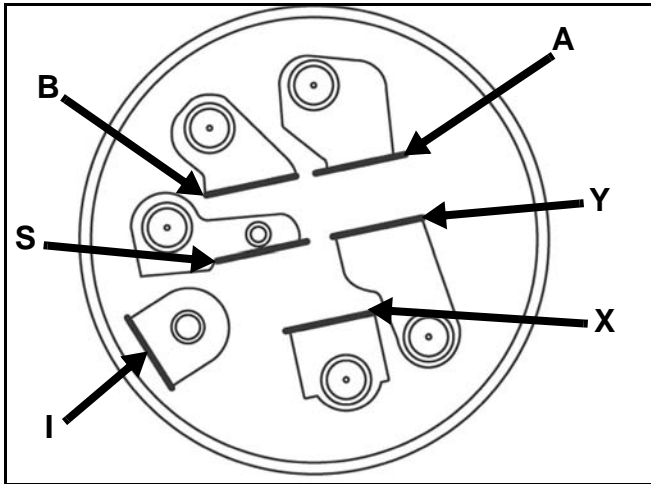

Figure 27

mvc-166

Position	Condition
Off	No continuity
Start	B + I + S
Run	B + I + A and X + Y

## Switch, Key

(P/N 99-7429)

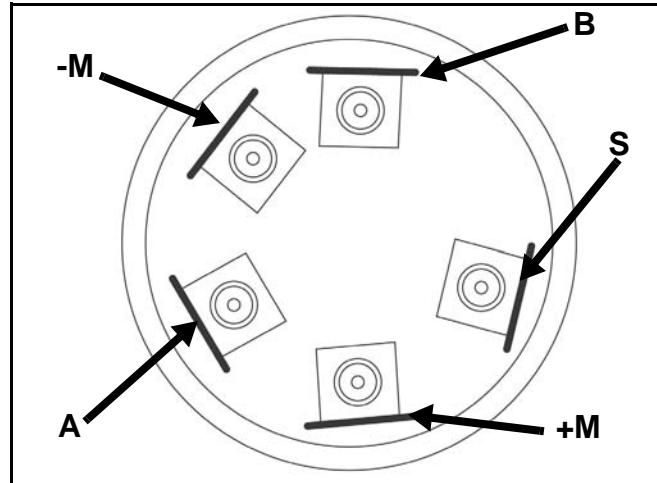

Figure 28

mvc-167x

### Purpose

This switch provides the proper switching for the starter, ignition, accessories, and safety circuits (Figure 28).

### How it Works

Detents inside the switch give it 3 positions: OFF, RUN, and START. The START position is spring loaded so the cylinder returns to RUN once the key is released.

## Testing

1. Disconnect the switch from the wiring harness.
2. Verify that continuity exists between the terminals listed for the switch position. Verify that there is NO continuity between terminals not listed for the switch (Figure 29).

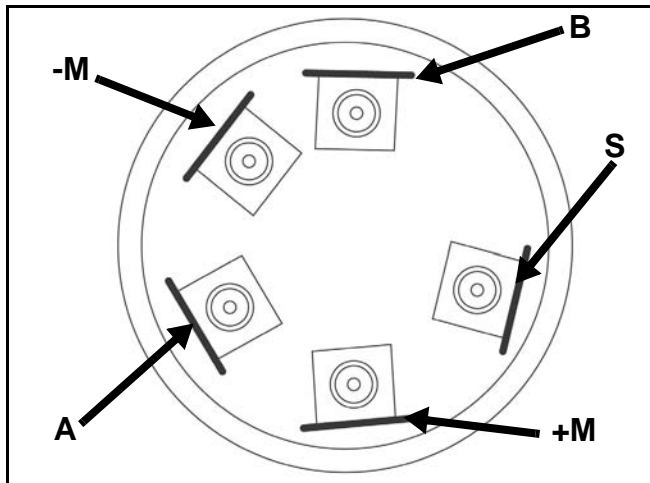

Figure 29

mvc-167x

Position	Condition
Off	+M + - M
Start	B + A + S
Run	B + A

## Switch, Key

(P/N 92-6785)

### Purpose

This component provides the proper switching for the starter, ignition, accessories, and safety circuits (Figure 30).

### How It Works

Detents inside the switch give it four positions: OFF, LIGHTS (ACCESSORIES), RUN, and START. The START position is spring loaded so the cylinder automatically returns to RUN once the key is released.

Terminals of the ignition switch as viewed from the terminal end (Figure 30).

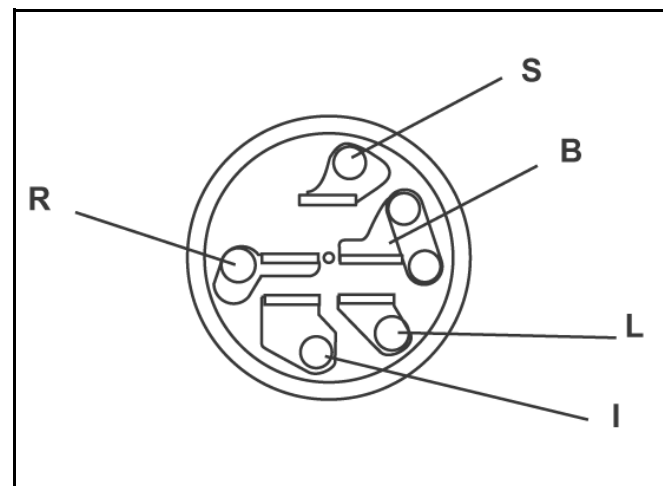

Figure 30

ignitionswitch1

B = Battery voltage "in"  
S = Starting Circuit  
I = Safety & Ignition Circuit

R = Regulator Circuit  
L = Light Circuit

# GLOSSARY

## Testing

1. Disconnect the switch from the wiring harness.
2. Verify that continuity exists between the terminals listed for the switch position. Verify that there is **NO** continuity between terminals not listed for the switch position (Figure 31).

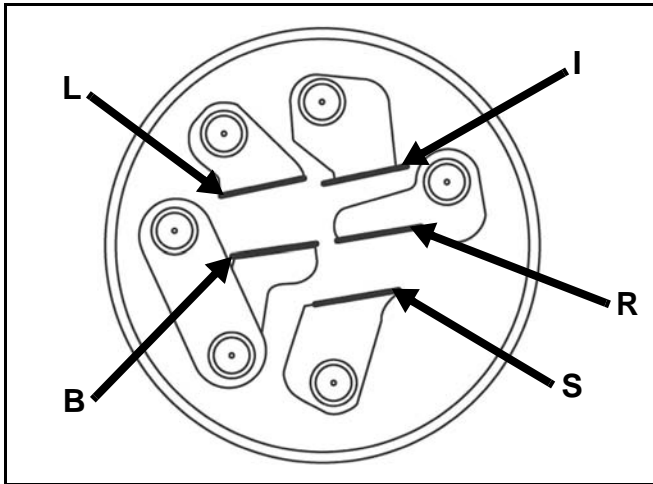

Figure 31

Position	Condition
Off	No Continuity
Start	B + I + S
Run	B + I + R
Run - Lights	B + I + R + L

## Switch, KeyChoice™ Reverse Operating System

### Purpose

This switch is used in the Key Choice™ Reverse Operating System circuit. When turned to the On position, it allows the operator to mow in reverse.

### How It Works

The switch is basically an on/off switch spring-loaded to return to the Off position. When turned to the On position with the PTO engaged, it activates circuits in the Key Choice™ Reverse Operating System reverse module and allows the operator to mow in reverse (Figure 32).



Figure 32

mvc-691

### Testing

1. Disconnect the switch from the circuit.
2. With a multimeter, check the continuity across the two terminals.
3. Turn the key to the on position and hold, since the switch is spring loaded. There should be continuity across the two terminals.



## Switch, Light

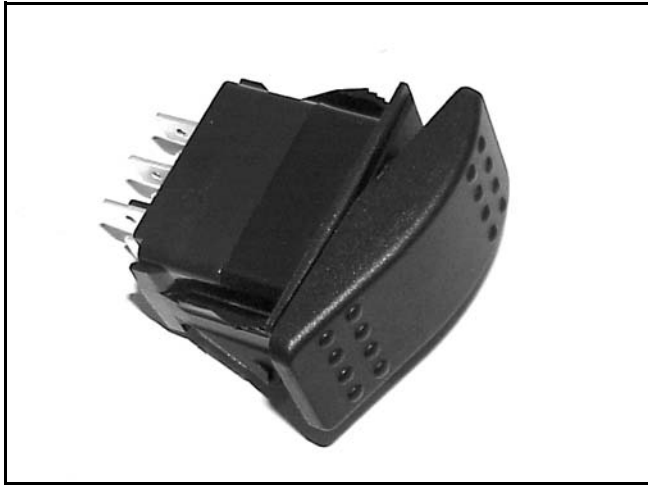

Figure 33

mvc-108

### Purpose

This rocker switch is typically used to provide switching for the lights (Figure 33).

### How it Works

The switch has contacts inside which connect two terminals in one position while disconnecting the other two. The rating on the switch is 20 amp capacity at 12 volts.

### Testing

1. Disconnect the switch from the wiring harness.
2. Using a VOM or test lamp, test the continuity of the terminals, using the diagrams below (Figure 34).

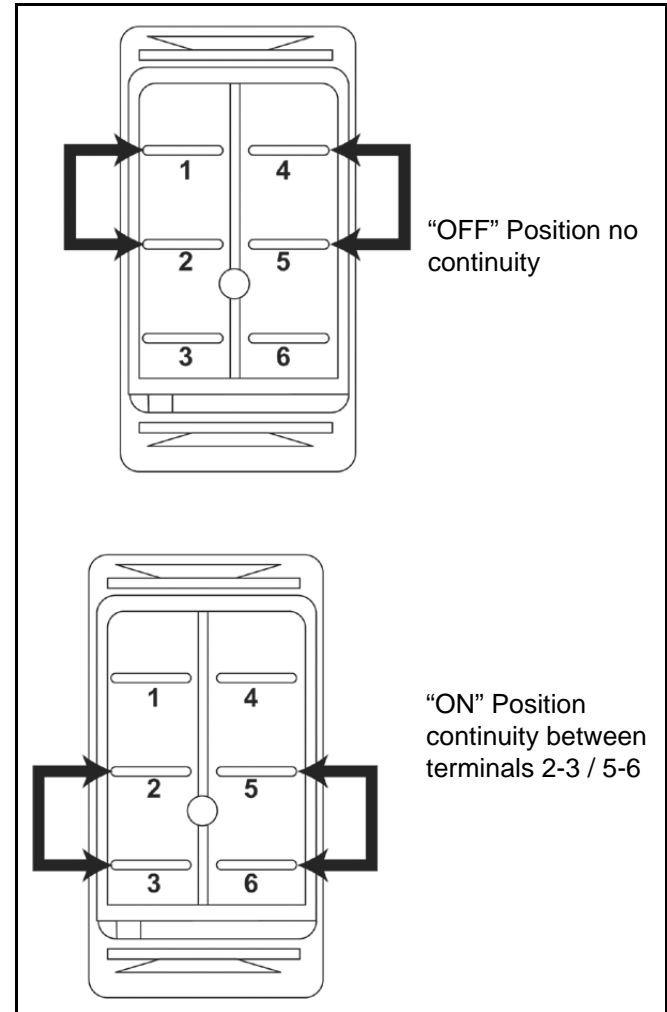

Figure 34

mvc162art

# GLOSSARY

## Switch, Neutral

### Purpose

Used to ensure the transmission is in neutral when starting the unit. It is activated when the clutch/brake pedal is depressed.

### How It Works

This single pole plunger type switch has two terminals. When the clutch/brake pedal is depressed, it pushes on the plunger, closing the contact, and connecting the two terminals (Figure 35).

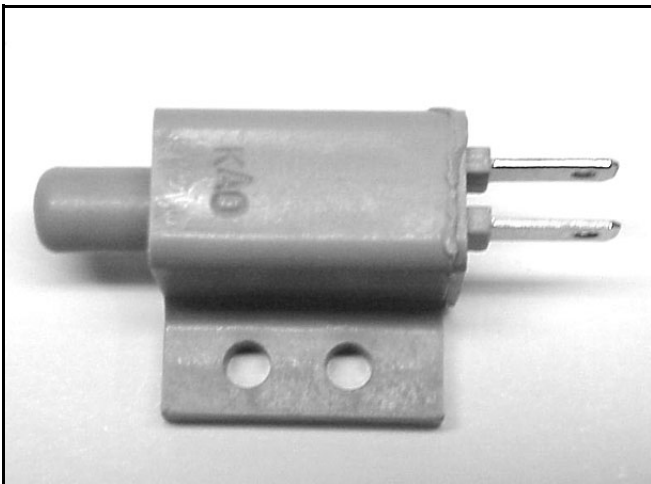

Figure 35

mvc-680

## Switch, Neutral - Plunger Type

### Purpose

Used to ensure the transmission is in neutral when starting the unit. It is activated when the brake pedal is depressed.

### How it Works

This double pole plunger type switch has four terminals (Figure 36). When the brake pedal is depressed, it pulls an arm that pushes on the plunger of the switch, closing the contacts, and connecting the four terminals.

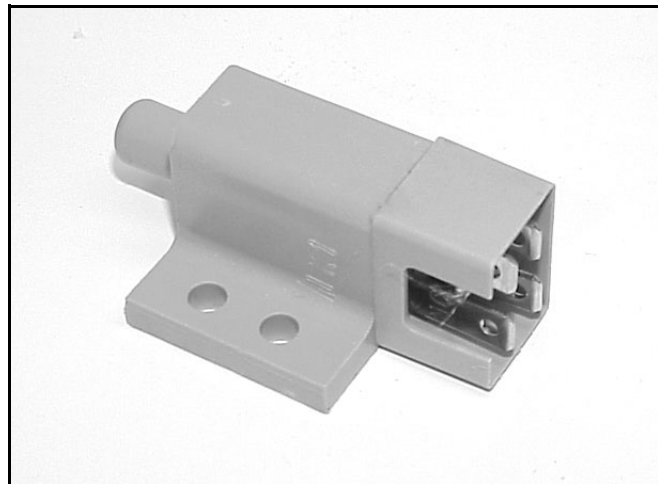

Figure 36

MVC-400X

### Testing

1. Disconnect the switch from the wiring harness.
2. Check first to ensure that there is NO continuity between either terminal. Foot OFF the pedal.
3. With the clutch/brake pedal depressed there should be continuity between the terminals.

## Testing

1. Disconnect the switch from the wiring harness.
2. Using a multimeter, follow the procedure listed below (Figure 37):

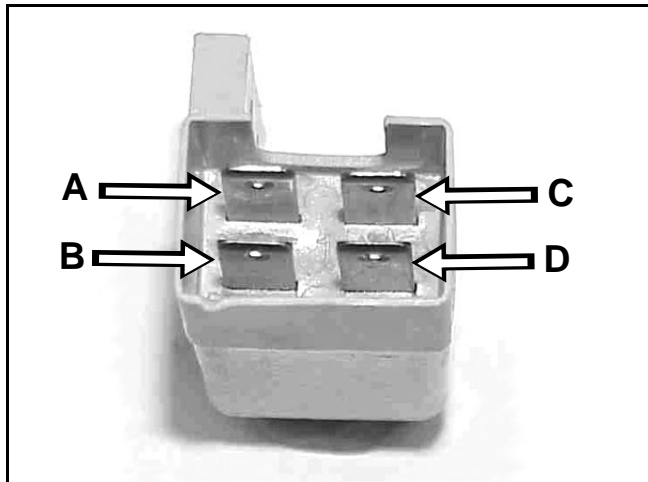
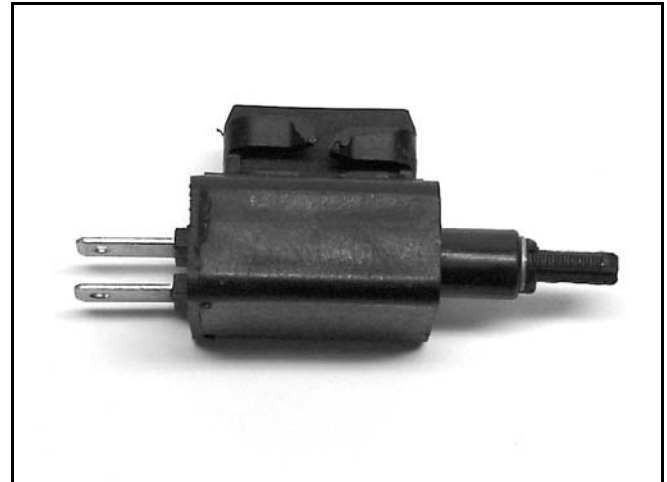

**Figure 37** Neutral Switch

**Note:** Terminals on actual switch not labeled.

Plunger <u>Not</u> Depressed	Plunger Depressed
A/B Terminals - Open Circuit - No Continuity	A/B Terminals - Closed Circuit - Continuity
C/D Terminals - Open Circuit - No Continuity	C/D Terminals - Closed Circuit - Continuity

## Switch, Neutral Adjustable - Plunger Type



**Figure 38** mvc-122

### Purpose

Used to ensure the transmission is in neutral and the park brake is engaged. It is activated when the forward/reverse control handles are in the start position (Figure 38).

### How it Works

This single pole plunger type switch has two terminals. When the forward/reverse control handle is in the start position (park position), it pushes on the plunger, closing the contact, and connecting the terminals.

### Testing

1. Disconnect the switch from the wiring harness.
2. Using a VOM or test lamp, check first to ensure that there is NO continuity between either terminal, plunger out.
3. With the plunger pushed in, there should be continuity between the terminals.

# GLOSSARY

## Switch, PTO

### Purpose

The PTO switch is typically used to turn on the Electric PTO Clutch and to function as part of the safety interlock system.

### How it Works

When the PTO switch is pulled out to the "ON" position, contacts inside the switch electrically connect various terminals. One terminal is connected to the wire that goes directly to the electric clutch. When the PTO is pulled out to the "ON" position, voltage flows to the electric clutch and engages.

### Testing

1. Disengage the PTO, set the parking brake, and turn the ignition to **OFF** and remove the key.
2. Disconnect the wiring harness from the PTO switch.
3. Press in on the locking tabs, on each side of the switch, and pull the switch out of the dash (towards the rear of the tractor).
4. Verify that there is continuity between the appropriate terminals in the "ON" and "OFF" positions, Figure 39.
5. Replace the switch if your test results do not correspond with those given in Figure 39.

Mount the PTO switch back into the dash and reinstall the wiring harness.

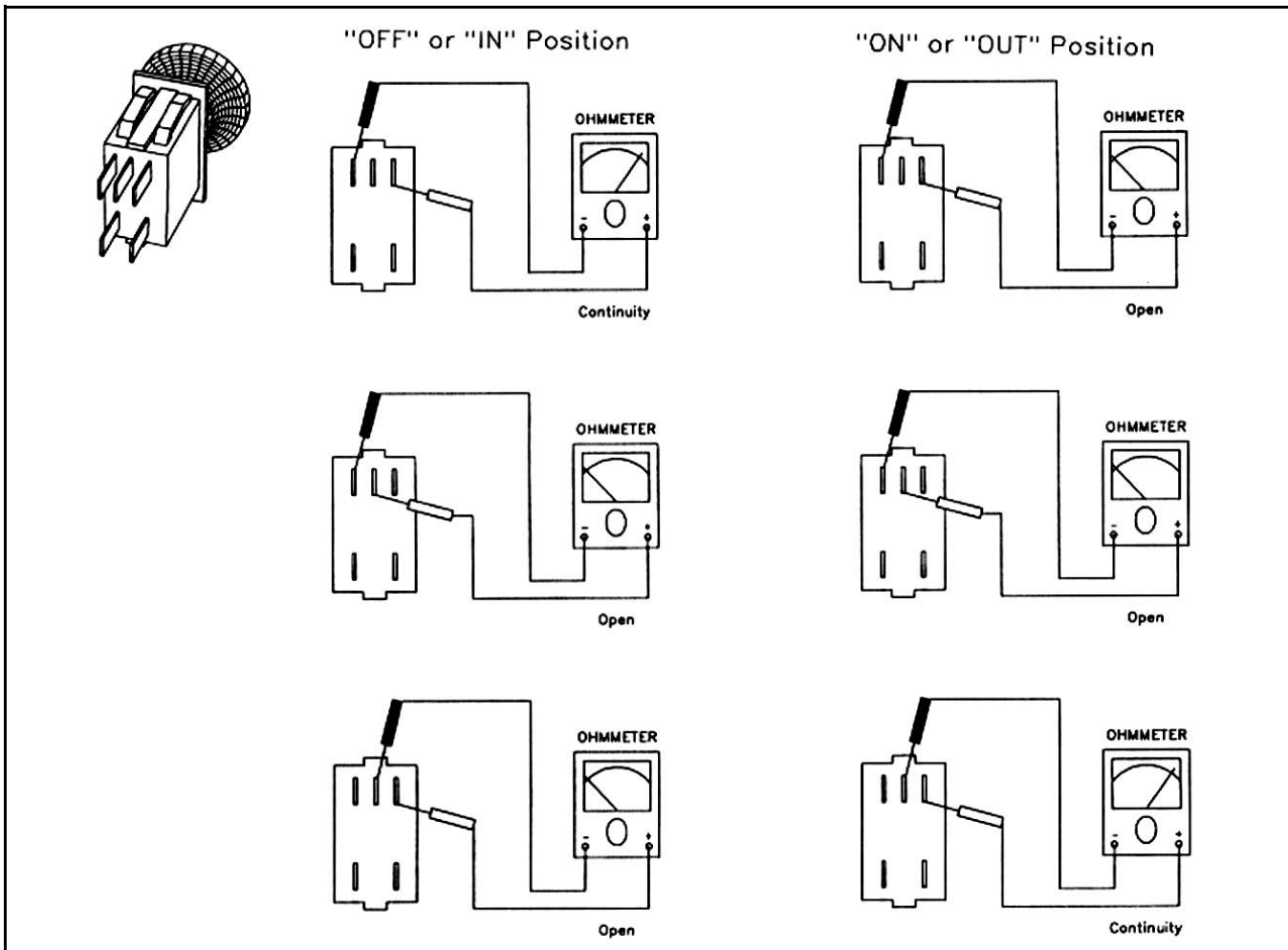

Figure 39

2-24

## Switch, Reverse

### Purpose

This switch works in the Key Choice™ Reverse Operating System circuit when the mower (PTO) is engaged.

### How It Works

This single pole plunger type switch has two terminals. When the unit is shifted in reverse while the mower blade (PTO engagement lever) is engaged, the reverse switch opens and will stop the engine, unless the KeyChoice switch has been operated.

### Testing

1. Disconnect the switch from the wiring circuit.
2. With a multimeter, check the continuity across the terminals. There should be continuity.
3. Depress the plunger on the switch and check the continuity across the terminals, there should be NO continuity (Figure 40).

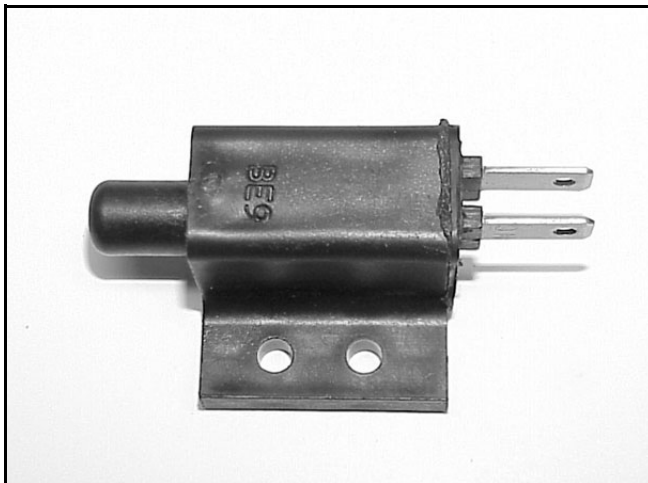

Figure 40

mvc-685

## Switch, Seat

### Purpose

The switch is in the safety circuit. If the engine is running and the operator vacates the seat with either PTO engaged or the parking brake off, the engine will shut down.

Seat switch (ribbon type) used on 2000 and prior models (Figure 41)

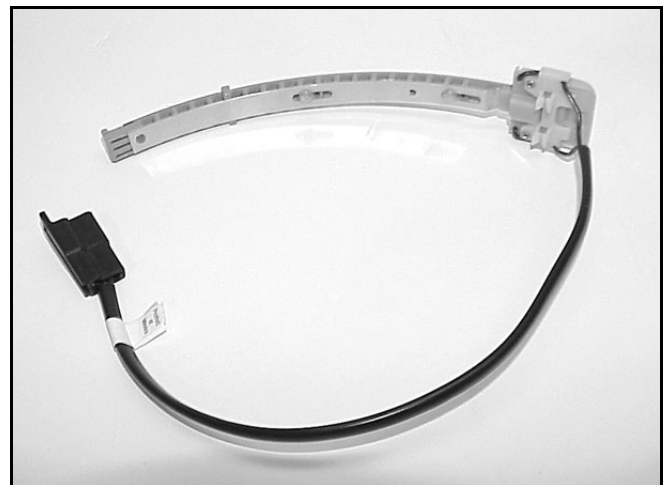

Figure 41

MVC-391x

Seat switch (mushroom type) used on 2001 and later models (Figure 42)



Figure 42

MVC-390x

# GLOSSARY

---

## How It Works

When the seat is vacated, the switch is open and there is no continuity between the two terminals. When the seat is occupied, the switch closes and there should be continuity between the two terminals.

## Testing

1. Disconnect the switch from the wiring harness.
2. With a multimeter, check the continuity between the two terminals of the switch. There should be NO continuity.
3. With weight or pressure on the seat, check the continuity again on the two terminals of the switch. There should be continuity.



**825 Information List (2002)**

Wiring Diagram ..... 4-2  
Circuit Diagrams  
    Starter Motor Circuit ..... 4-3  
    Spark Circuits ..... 4-3 - 4-6  
    Charging Circuit ..... 4-6

Wiring Diagram

Wiring Diagram

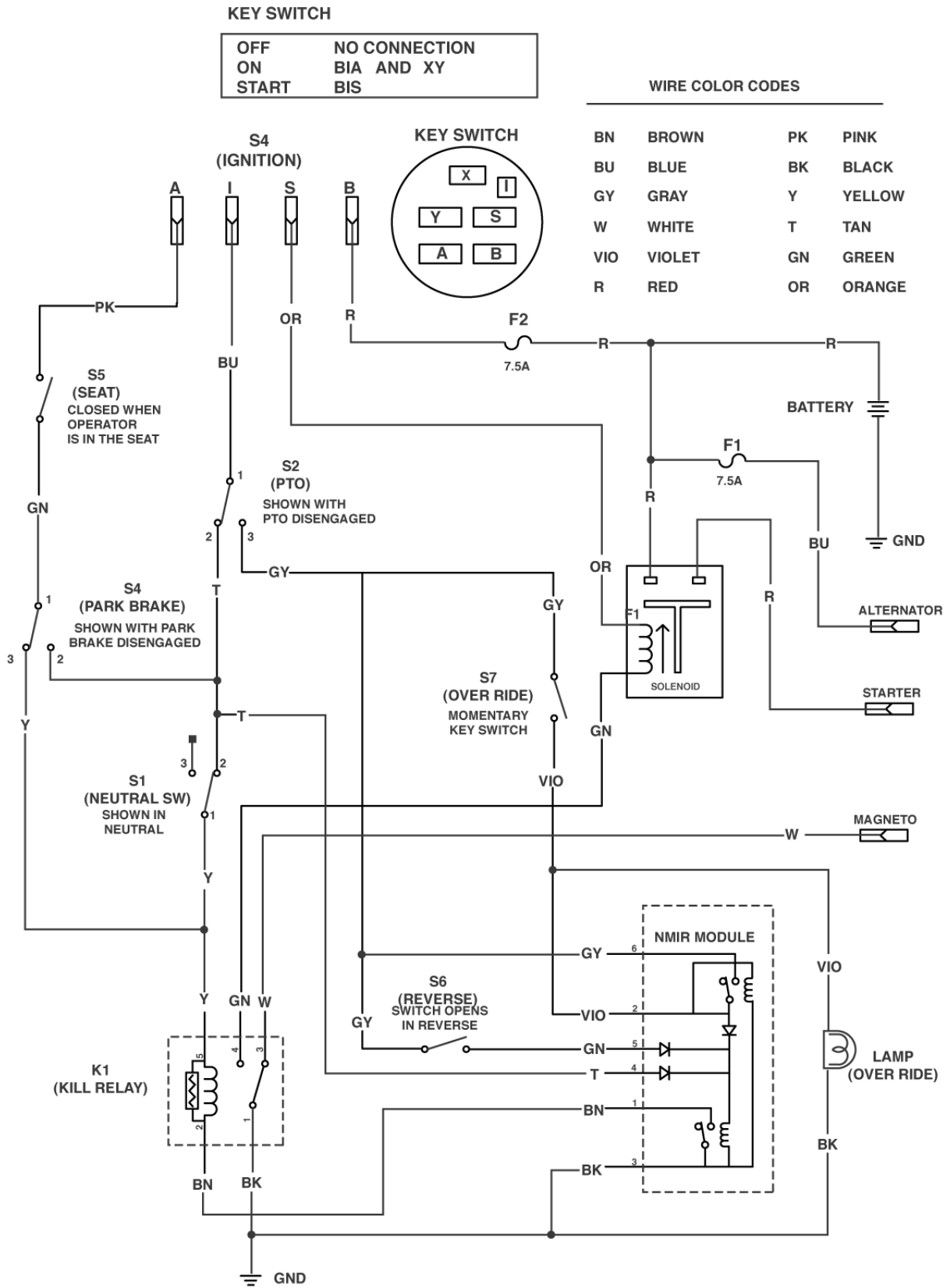



**Starter Motor Circuit**  
(ignition switch in "start")

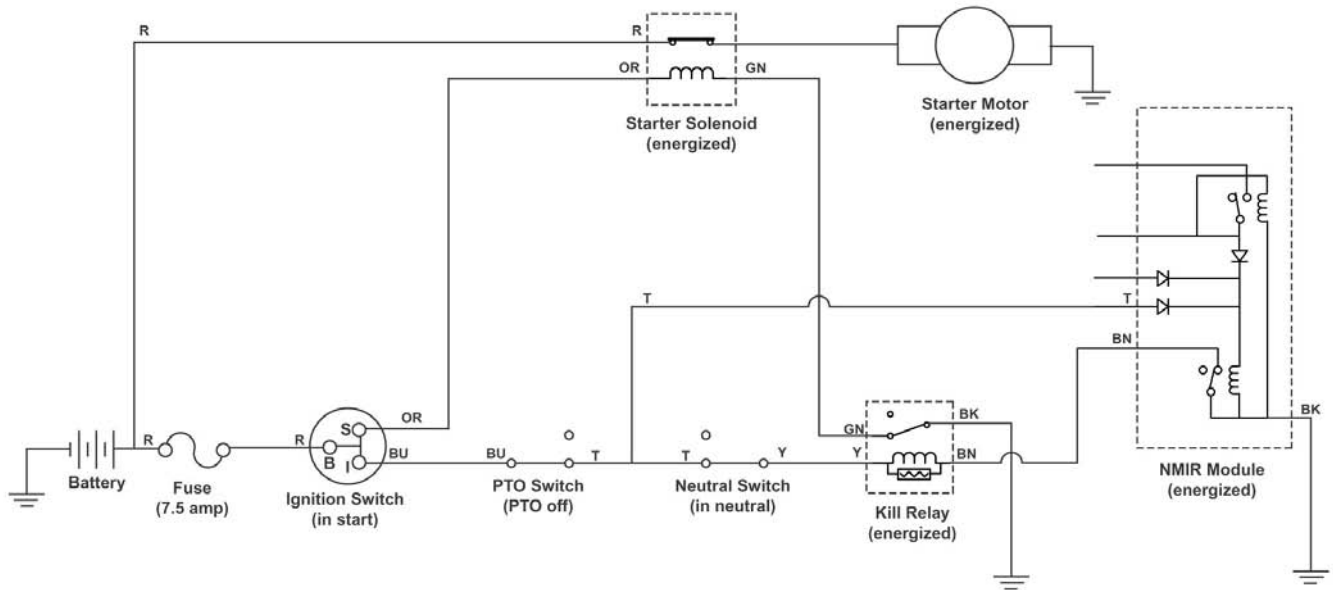

**Spark Circuit**  
(ignition switch in "start")

Legend	
Black	Bk
Blue	Bu
Brown	Bn
Green	Gn
Grey	Gy
Orange	Or
Pink	Pk
Red	Re
Tan	T
Violet	Vio
White	W
Yellow	Y

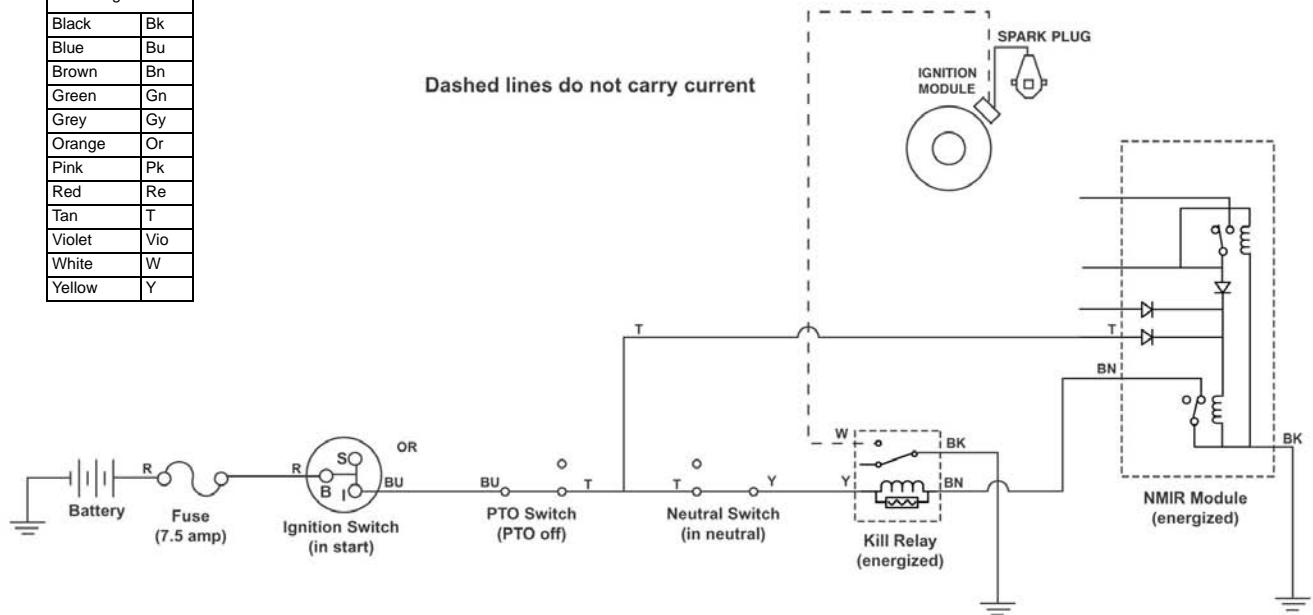

**Circuits**

**Spark Circuit**  
(ignition switch in "run")

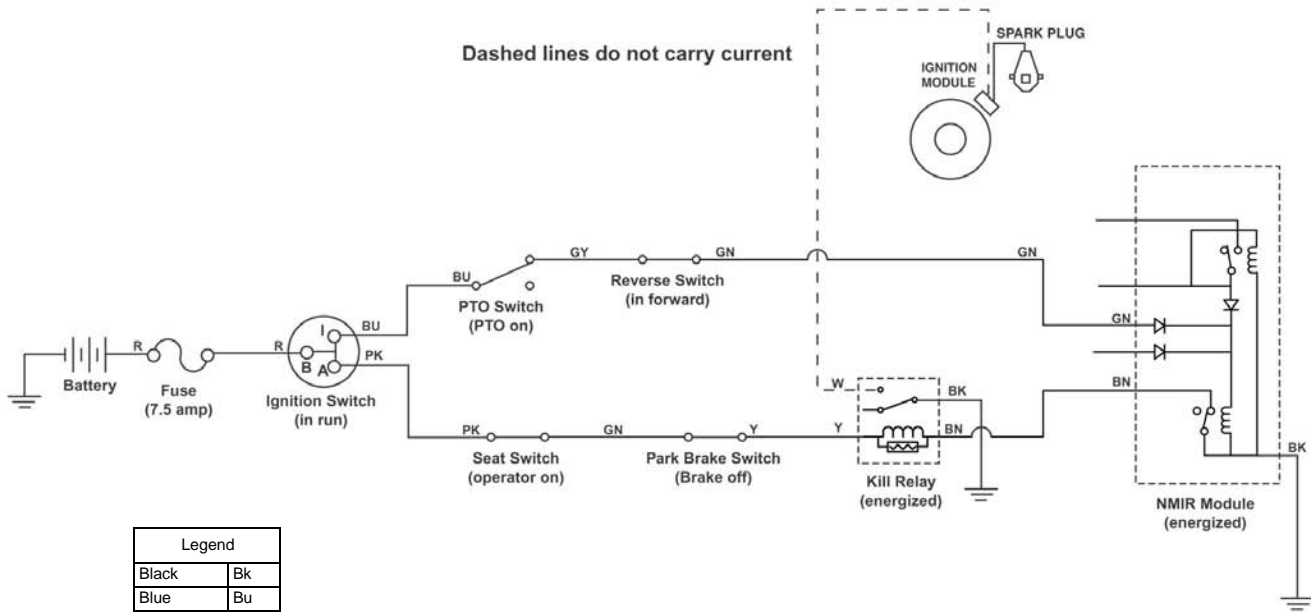

Legend	
Black	Bk
Blue	Bu
Brown	Bn
Green	Gn
Grey	Gy
Orange	Or
Pink	Pk
Red	Re
Tan	T
Violet	Vio
White	W
Yellow	Y

**Spark Circuit**  
(In reverse, PTO "on")

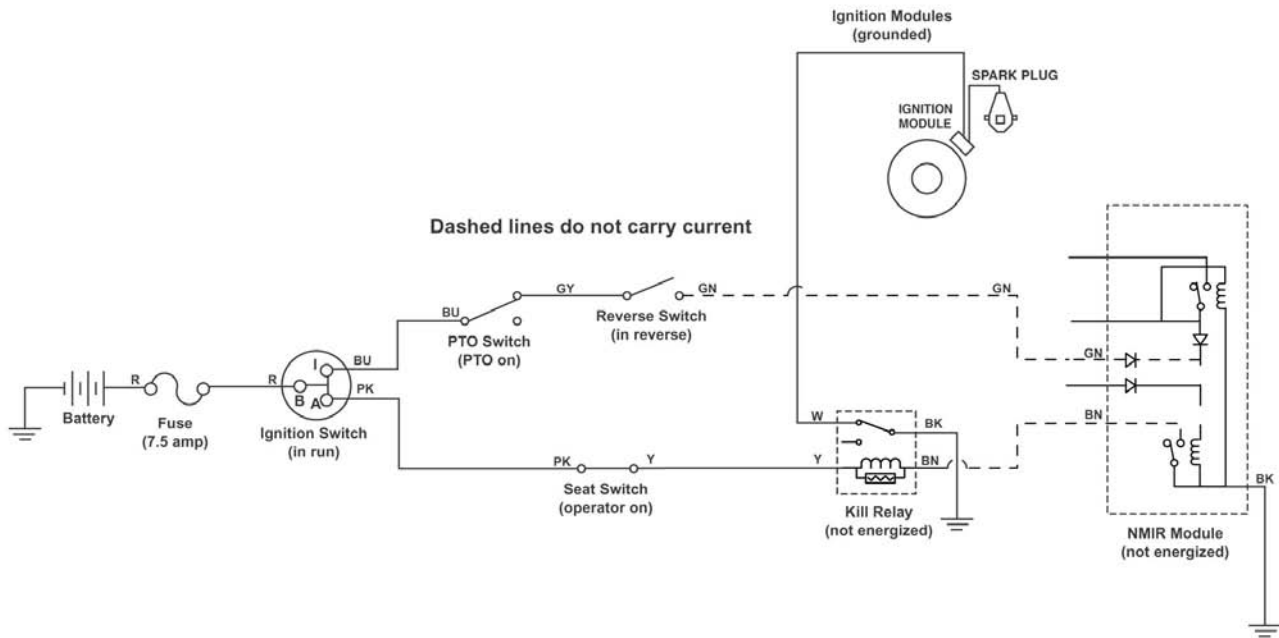

**Spark Circuit**  
(In reverse, override key switch activated)

Legend	
Black	Bk
Blue	Bu
Brown	Bn
Green	Gn
Grey	Gy
Orange	Or
Pink	Pk
Red	Re
Tan	T
Violet	Vio
White	W
Yellow	Y

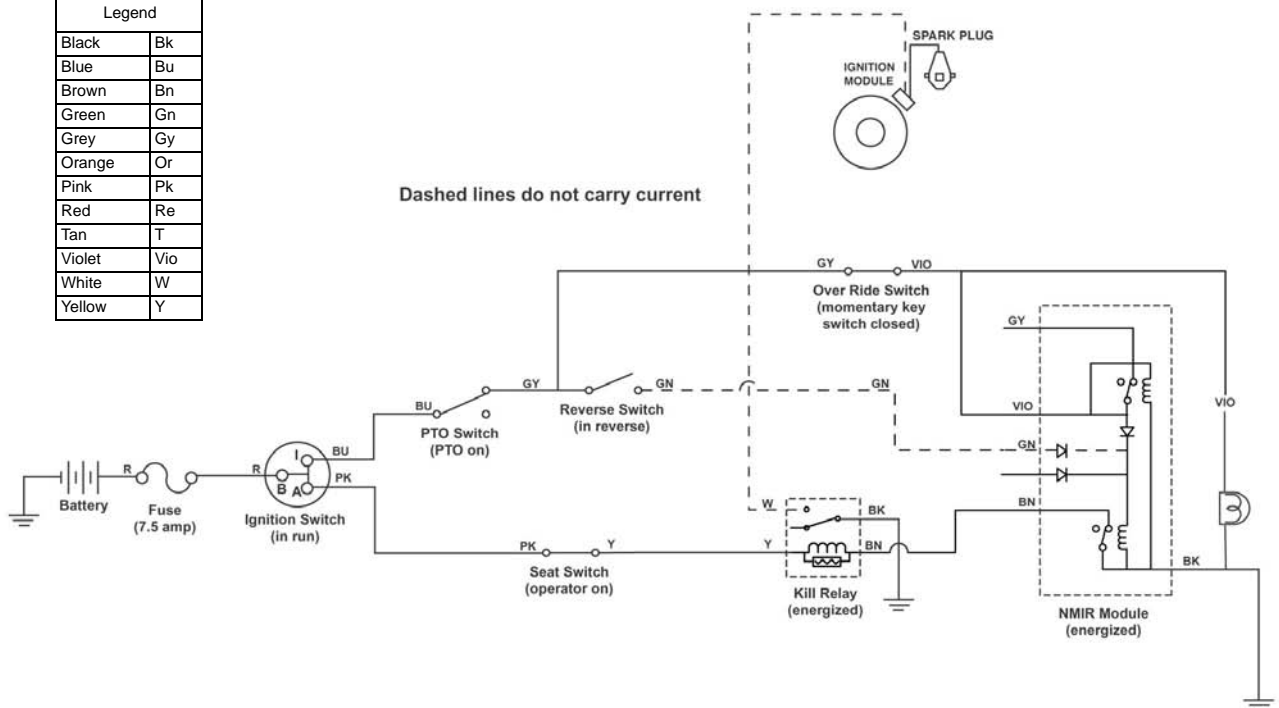

**Circuits**

**Spark Circuit**

(In reverse PTO "on", override mode)

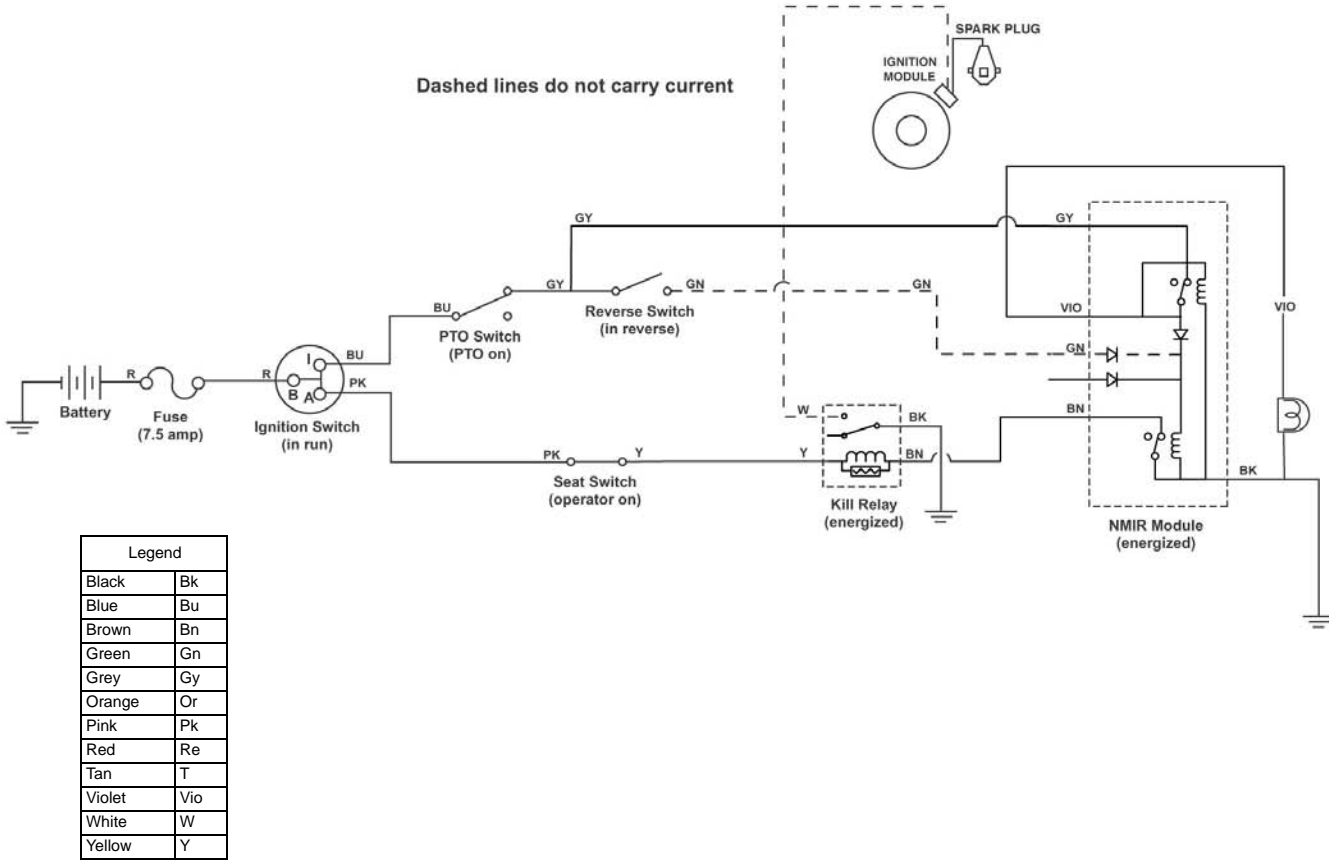

**Charging Circuit**

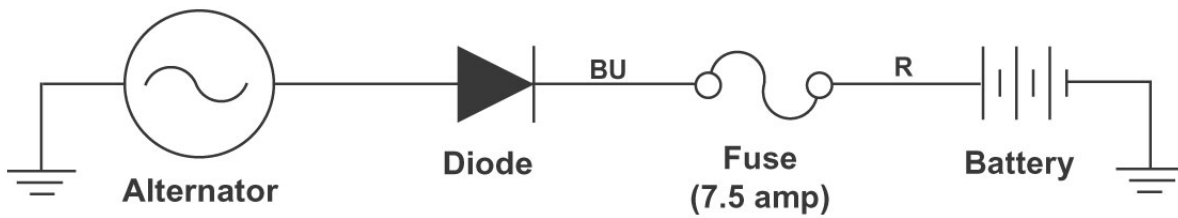



**12-32 Information List (2002)**

Wiring Diagram ..... 5-2  
Circuit Diagrams  
    Starter Motor Circuit ..... 5-3  
    Spark Circuits ..... 5-3 - 5-6  
    Charging Circuit ..... 5-6

Wiring Diagram

KEY SWITCH

OFF	NO CONNECTION
ON	BIA AND XY
START	BIS

WIRE COLOR CODES

BN	BROWN	PK
BU	BLUE	BK
GY	GRAY	Y
W	WHITE	T
VIO	VIOLET	GN
R	RED	OR

Wiring Diagram

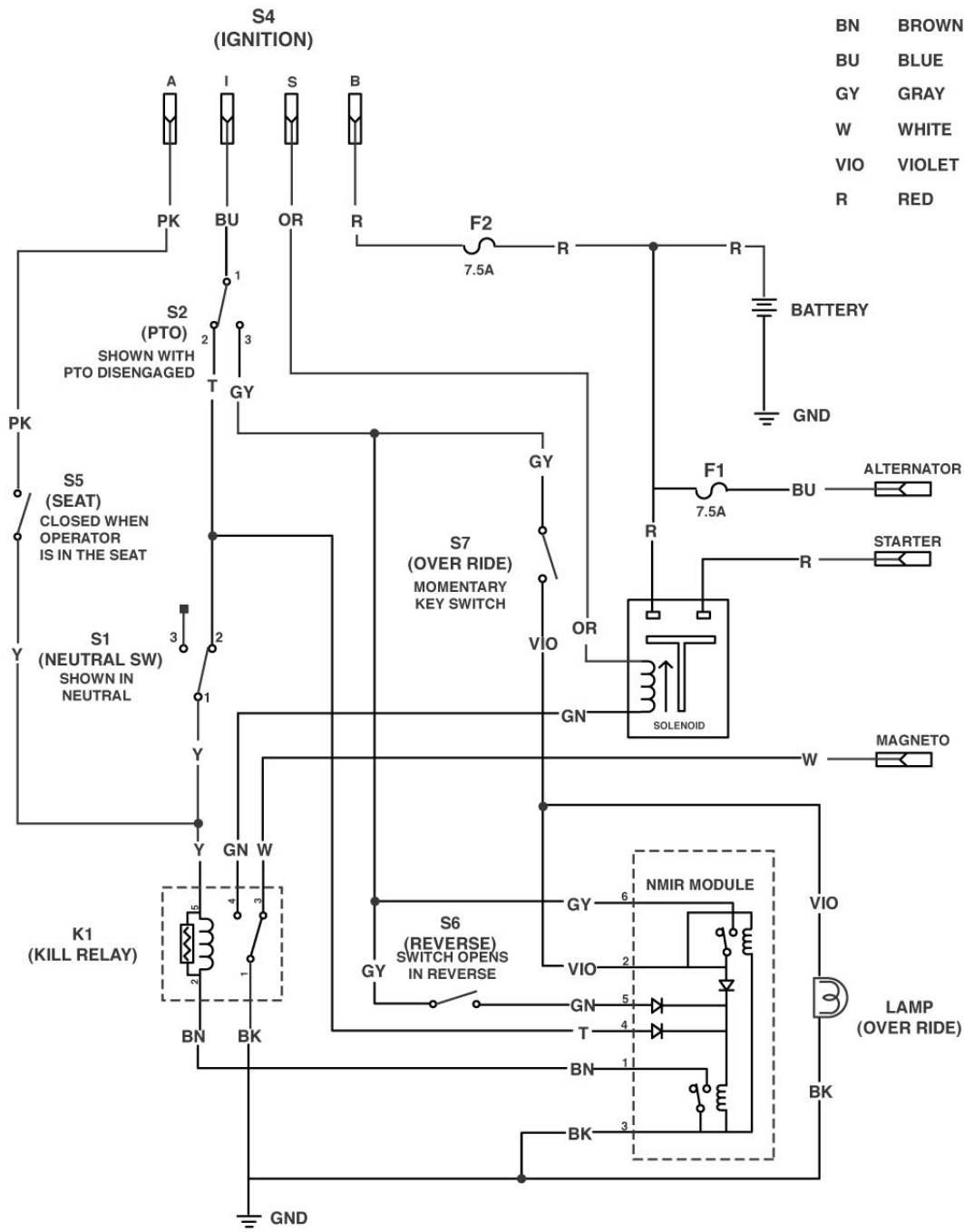

**Starter Motor Circuit**  
(ignition switch in "start")

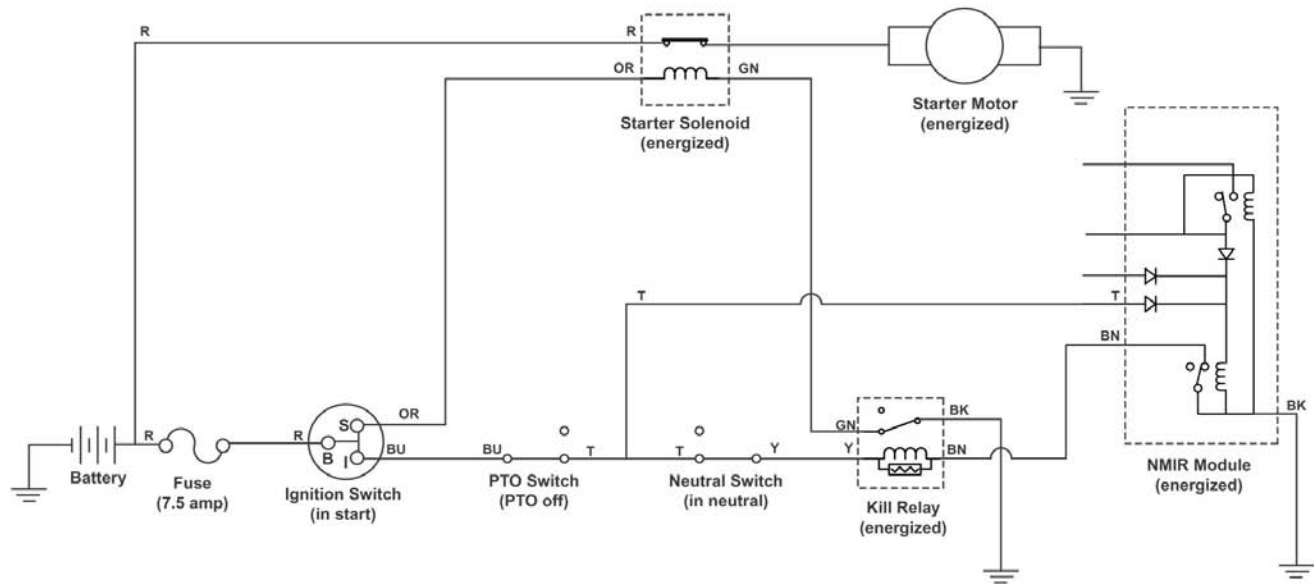

**Spark Circuit**  
(ignition switch in "start")

Legend	
Black	Bk
Blue	Bu
Brown	Bn
Green	Gn
Grey	Gy
Orange	Or
Pink	Pk
Red	Re
Tan	T
Violet	Vio
White	W
Yellow	Y

Dashed lines do not carry current

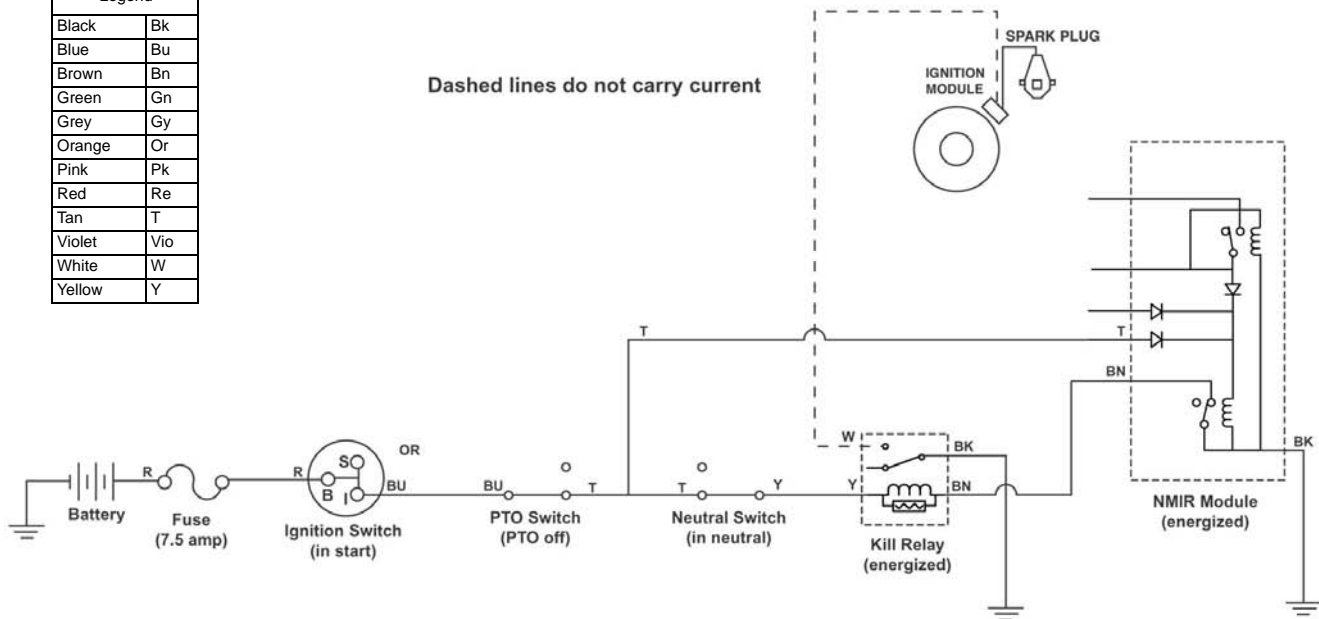

**Circuits**

**Spark Circuit**  
(ignition switch in "run")

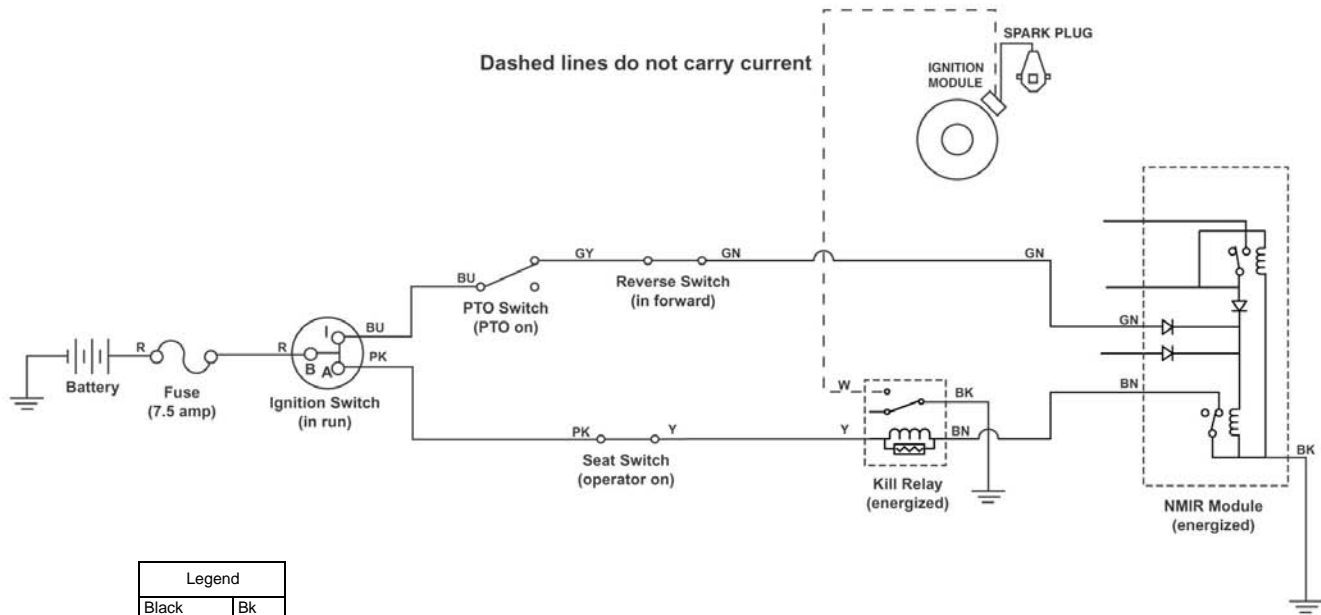

Legend	
Black	Bk
Blue	Bu
Brown	Bn
Green	Gn
Grey	Gy
Orange	Or
Pink	Pk
Red	Re
Tan	T
Violet	Vio
White	W
Yellow	Y



**Spark Circuit**  
(In reverse, PTO "on")

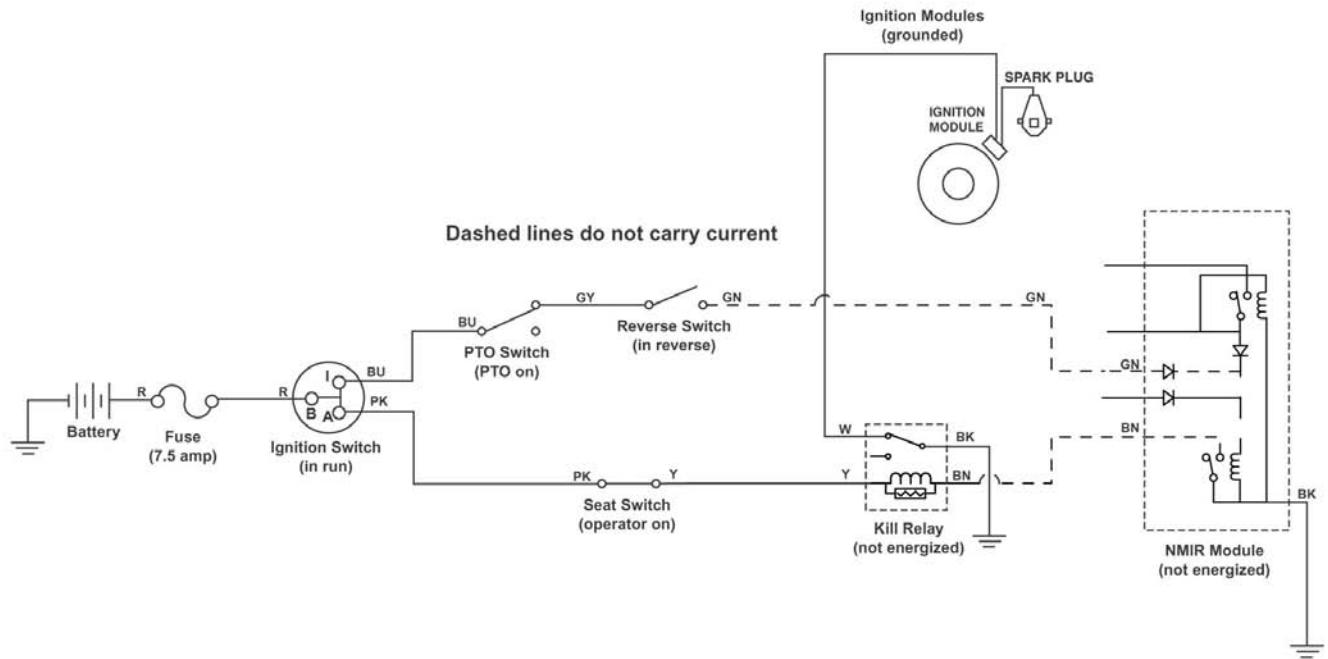

**Spark Circuit**  
(In reverse, override key switch activated)

Legend	
Black	Bk
Blue	Bu
Brown	Bn
Green	Gn
Grey	Gy
Orange	Or
Pink	Pk
Red	Re
Tan	T
Violet	Vio
White	W
Yellow	Y

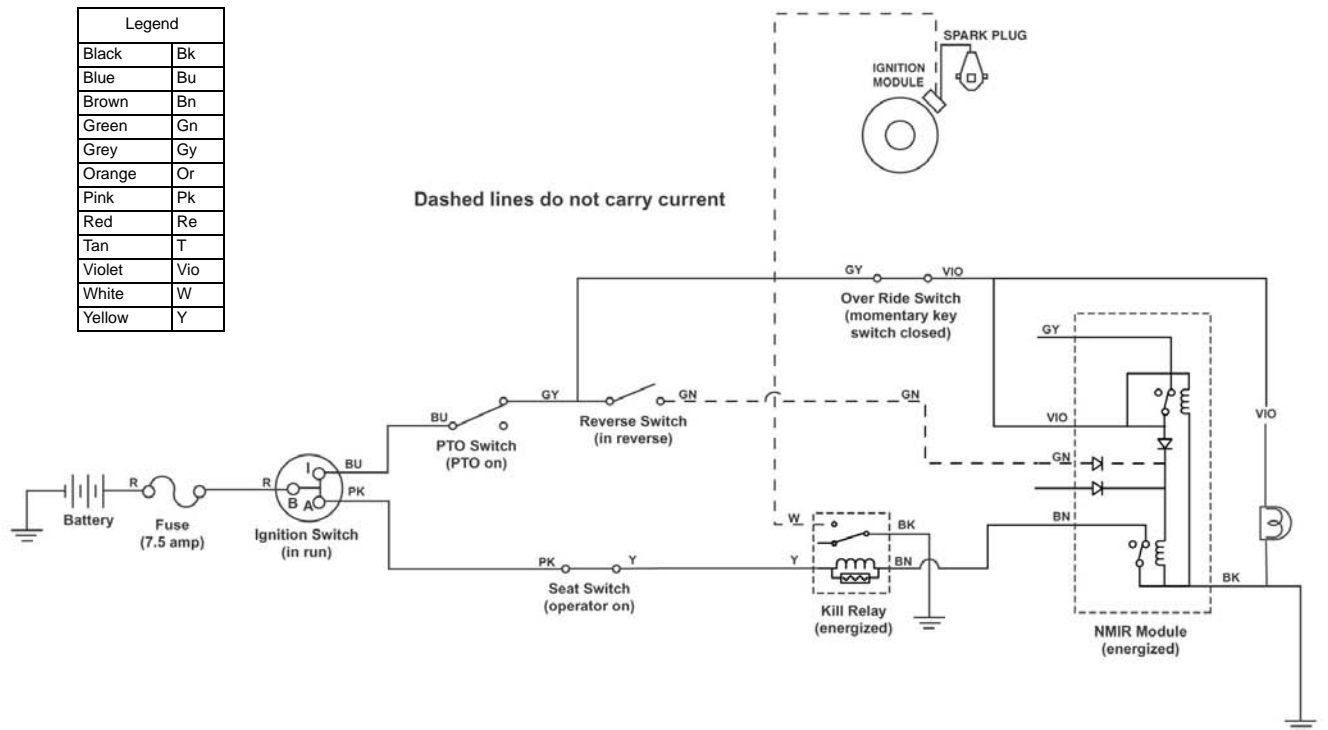

**Circuits**

**Spark Circuit**

(In reverse, PTO "on", override mode)

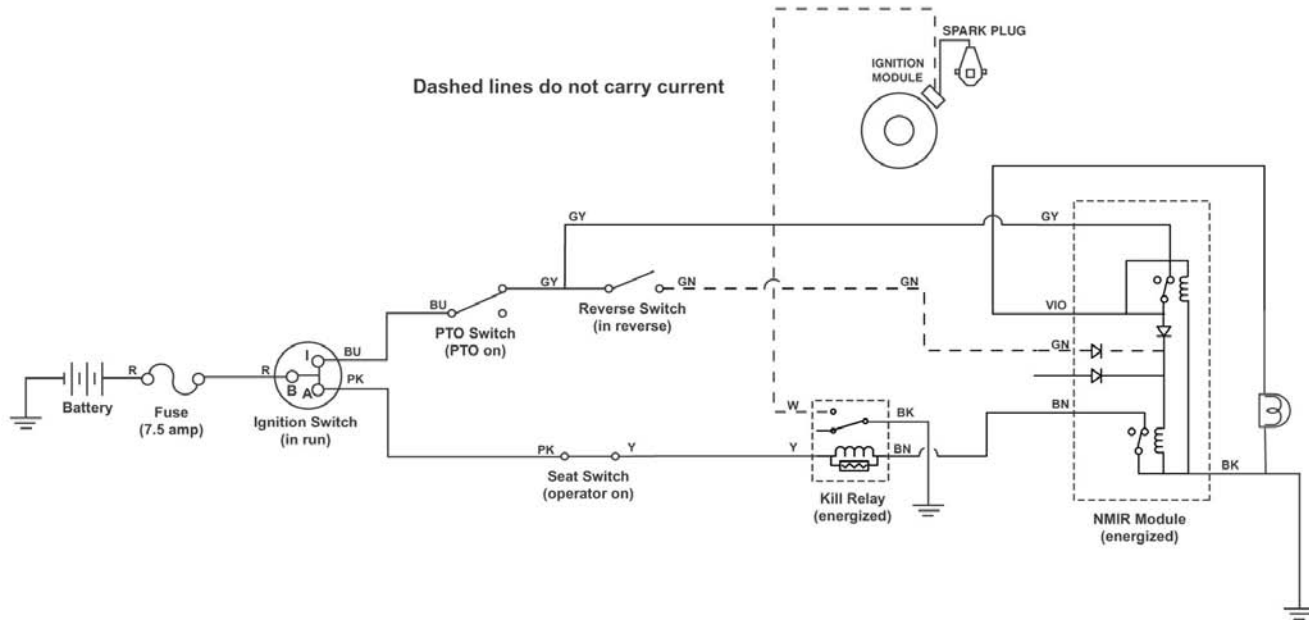

**Charging Circuit**

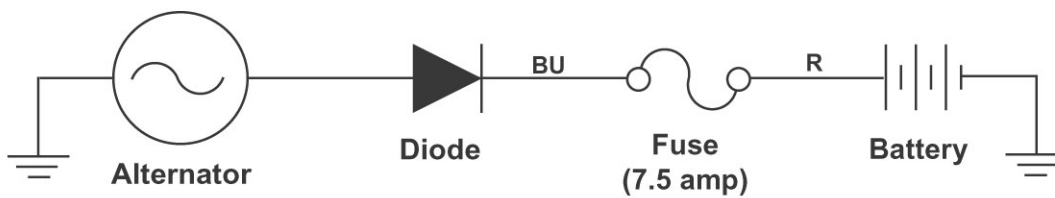

**Circuits**

Legend	
Black	Bk
Blue	Bu
Brown	Bn
Green	Gn
Grey	Gy
Orange	Or
Pink	Pk
Red	Re
Tan	T
Violet	Vio
White	W
Yellow	Y



**XL Information List (2002 - 2003)**

Wiring Diagram ..... 6-2

Circuit Diagrams

- Starter Motor Circuit ..... 6-3
- Spark Circuit ..... 6-3 - 6-6
- Charging Circuit ..... 6-6
- Light Circuit ..... 6-6

Wiring Diagram

Wiring Diagram

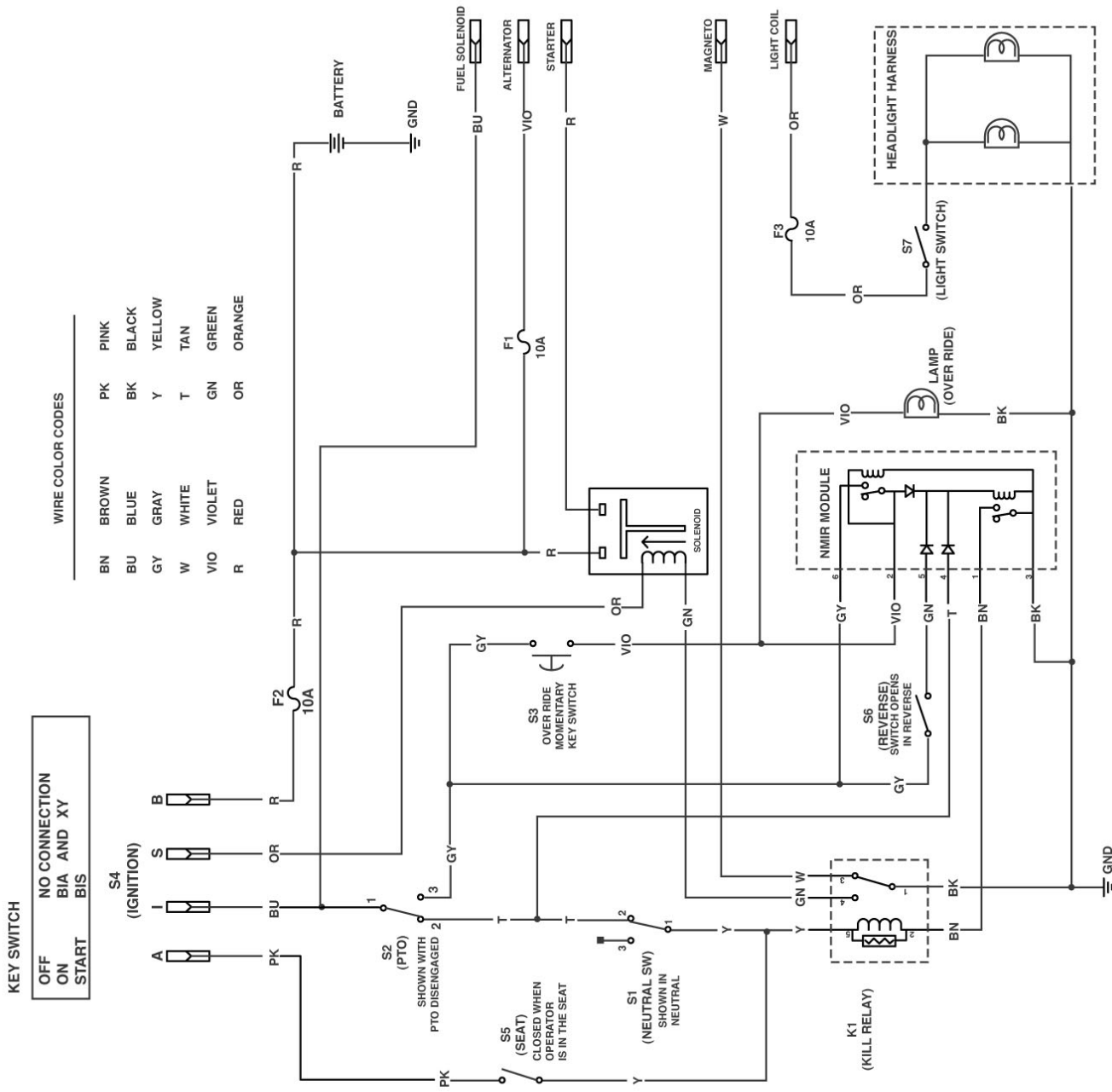

**Starter Motor Circuit**  
(ignition switch in "start")

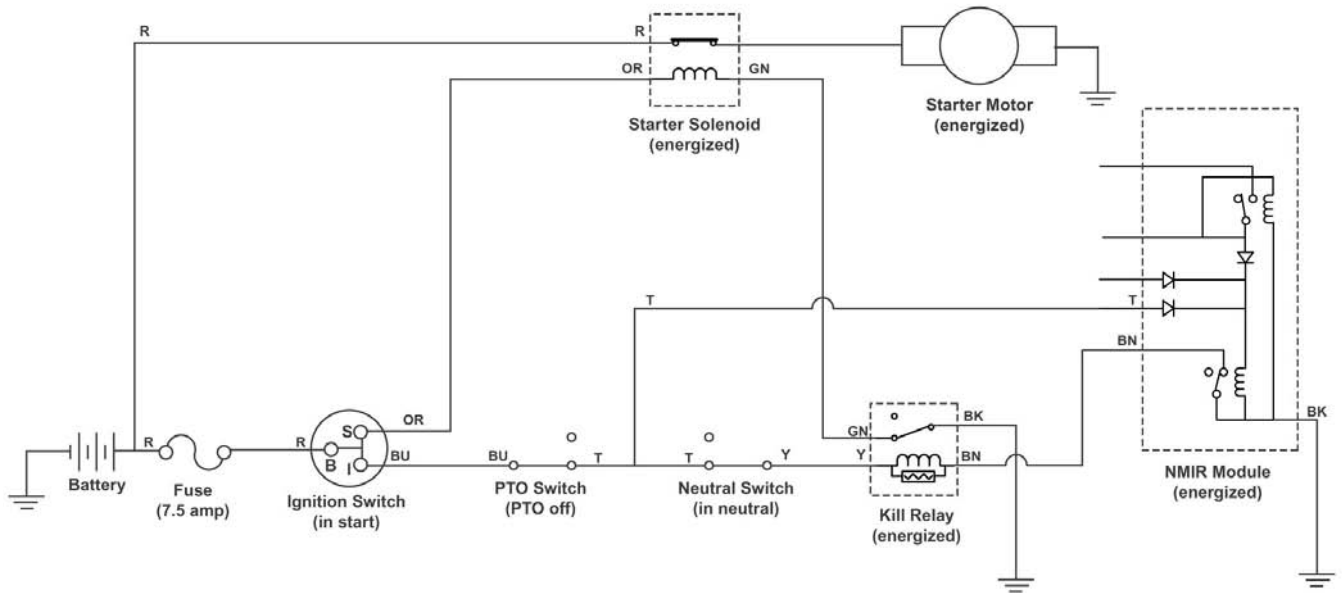

**Spark Circuit**  
(ignition switch in "start")

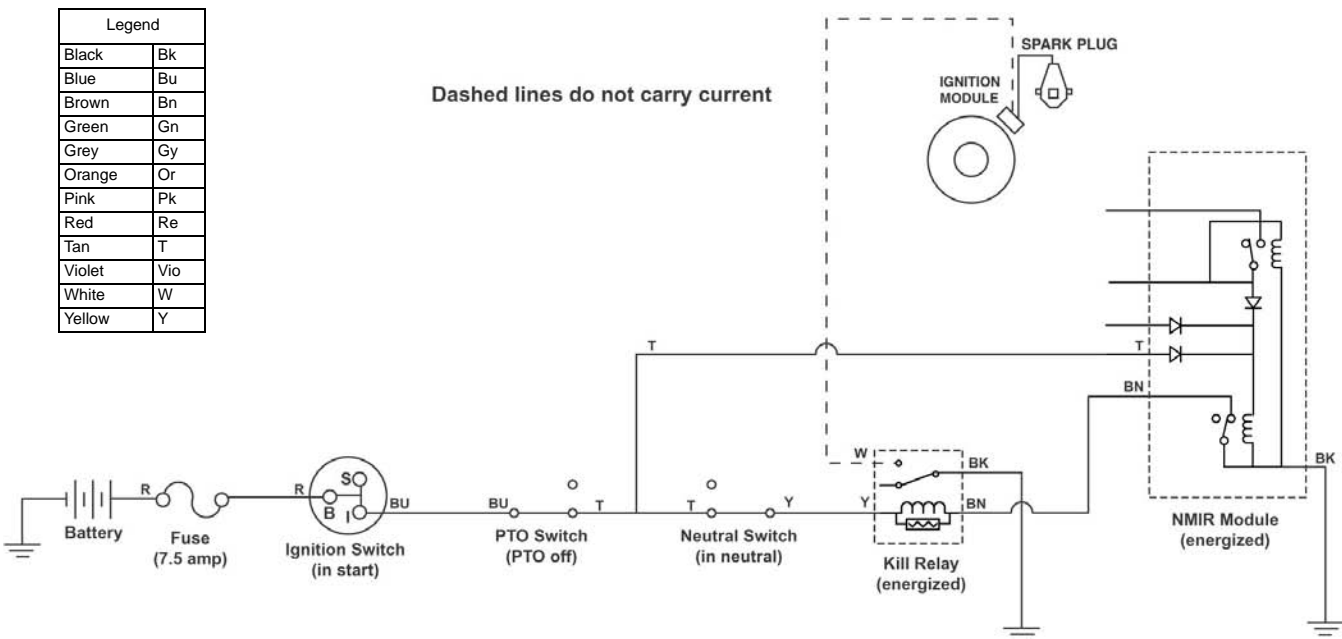

**Circuits**

**Spark Circuit**  
(ignition switch in "run")

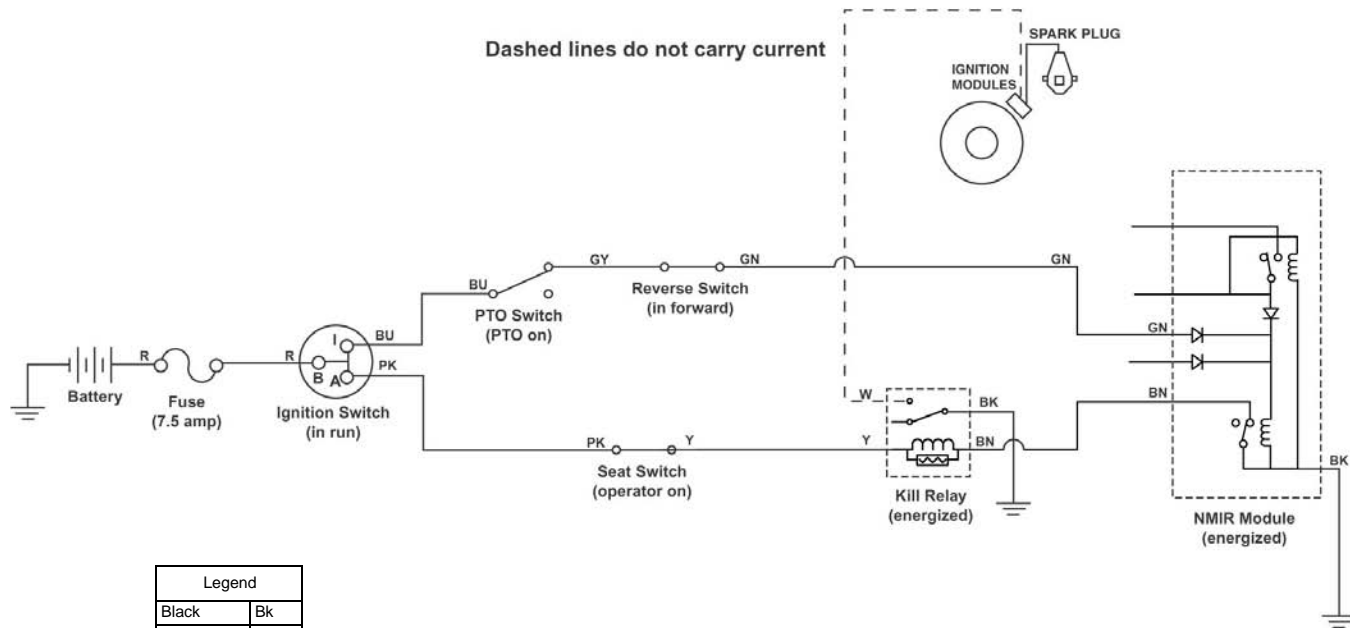

Legend	
Black	Bk
Blue	Bu
Brown	Bn
Green	Gn
Grey	Gy
Orange	Or
Pink	Pk
Red	Re
Tan	T
Violet	Vio
White	W
Yellow	Y

**Spark Circuit**  
(In reverse, PTO "on")

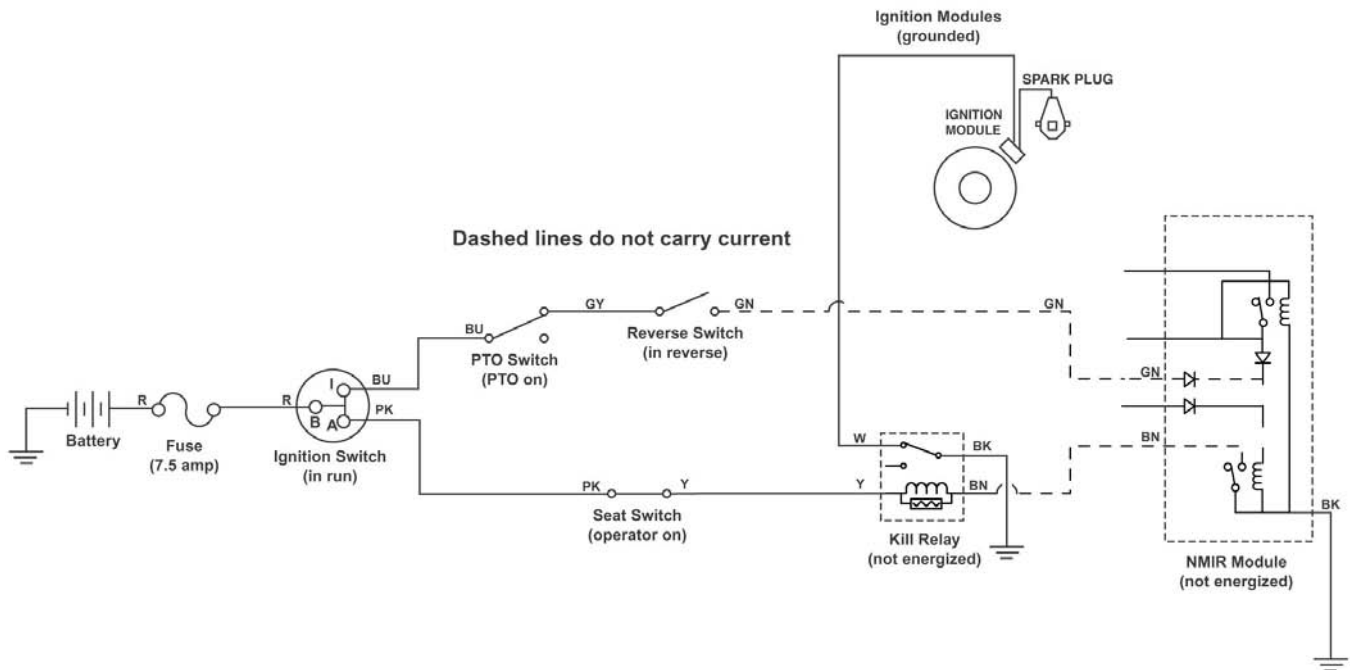

**Spark Circuit**  
(In reverse, override key switch activated)

Legend	
Black	Bk
Blue	Bu
Brown	Bn
Green	Gn
Grey	Gy
Orange	Or
Pink	Pk
Red	Re
Tan	T
Violet	Vio
White	W
Yellow	Y

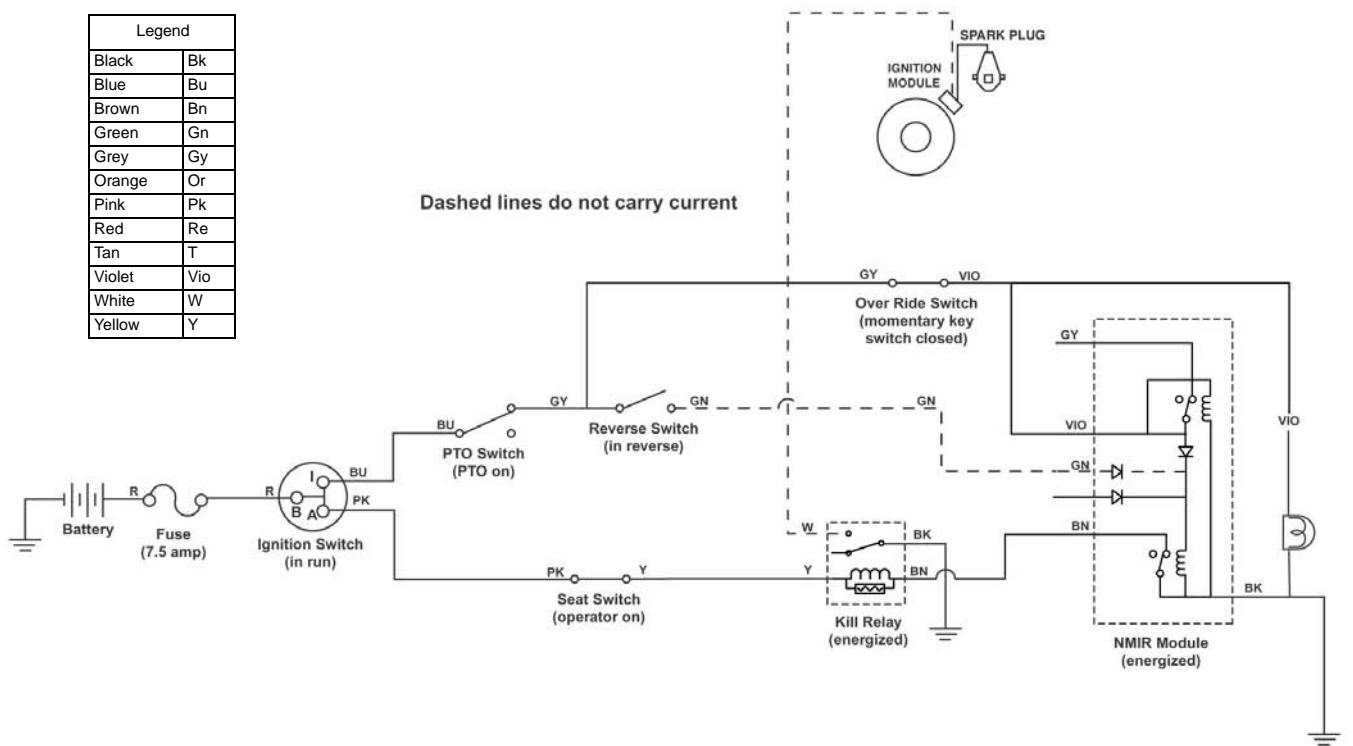

**Circuits**

**Spark Circuit**

*(In reverse, PTO "on", override mode)*

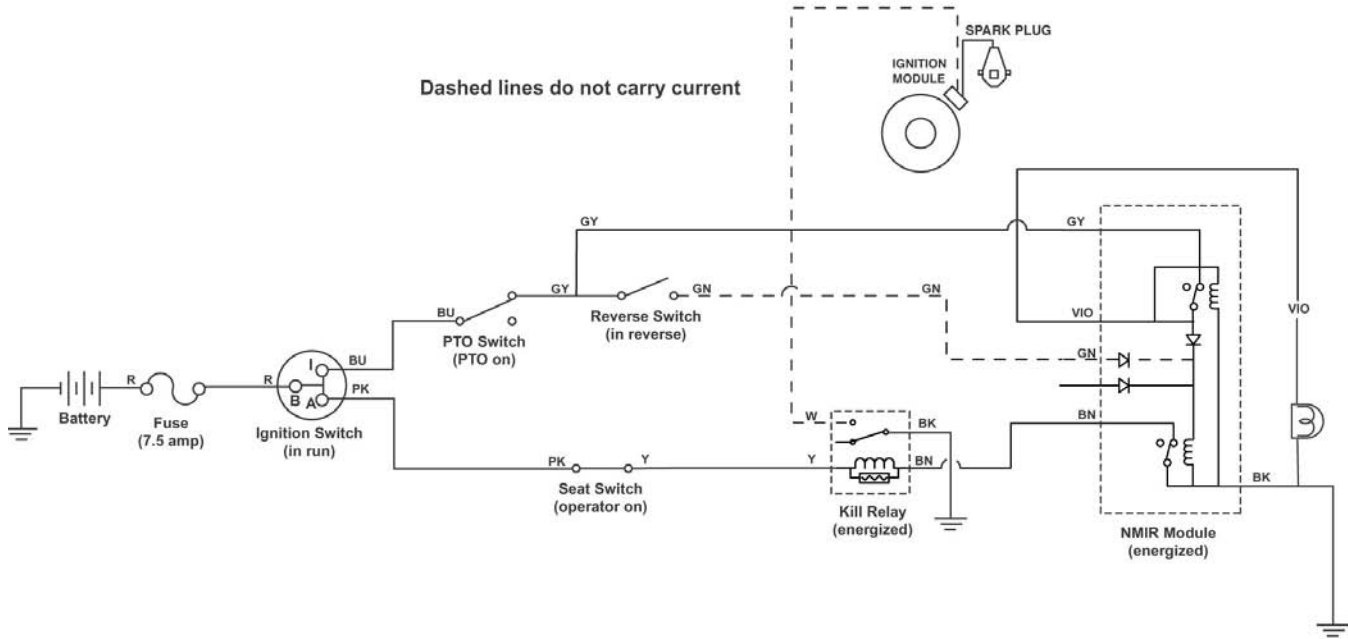

**Charging Circuit**

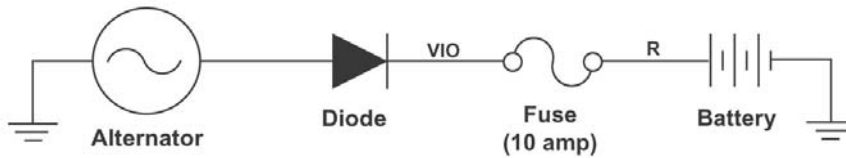

**Light Circuit**

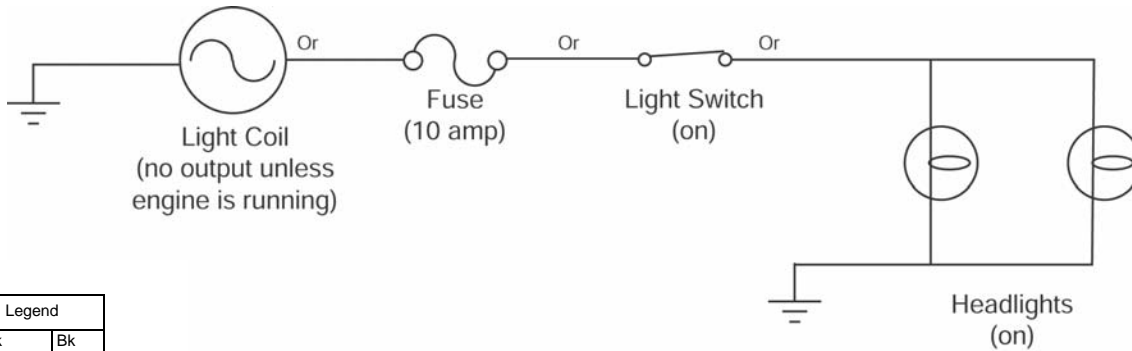

Legend	
Black	Bk
Blue	Bu
Brown	Bn
Green	Gn
Grey	Gy
Orange	Or
Pink	Pk
Red	Re
Tan	T
Violet	Vio
White	W
Yellow	Y





**266-H Information List (2002)**

Wiring Diagrams . . . . . 7-3 & 7-3  
Circuit Diagrams  
    Starter Motor Circuit . . . . . 7-4  
    Spark Circuits . . . . . 7-4 & 7-5  
    Reverse Operating System Circuits 7-6 - 7-10  
    Charging Circuit . . . . . 7-11  
    Light Circuit . . . . . 7-11  
    Hourmeter Circuit . . . . . 7-12  
    Oil Pressure Light Circuit . . . . . 7-12

Wiring Diagram

Wiring Diagram

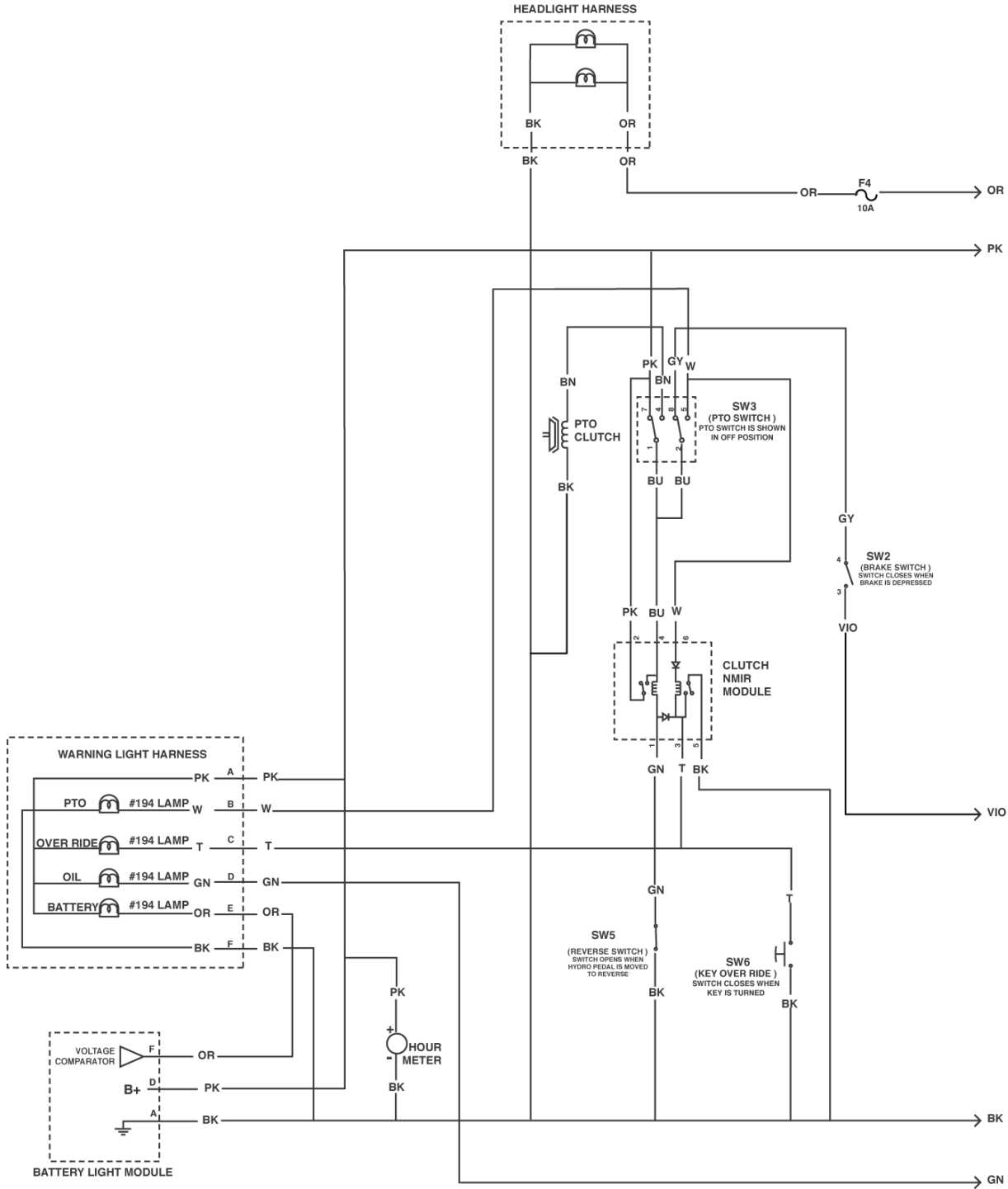

Wiring Diagram

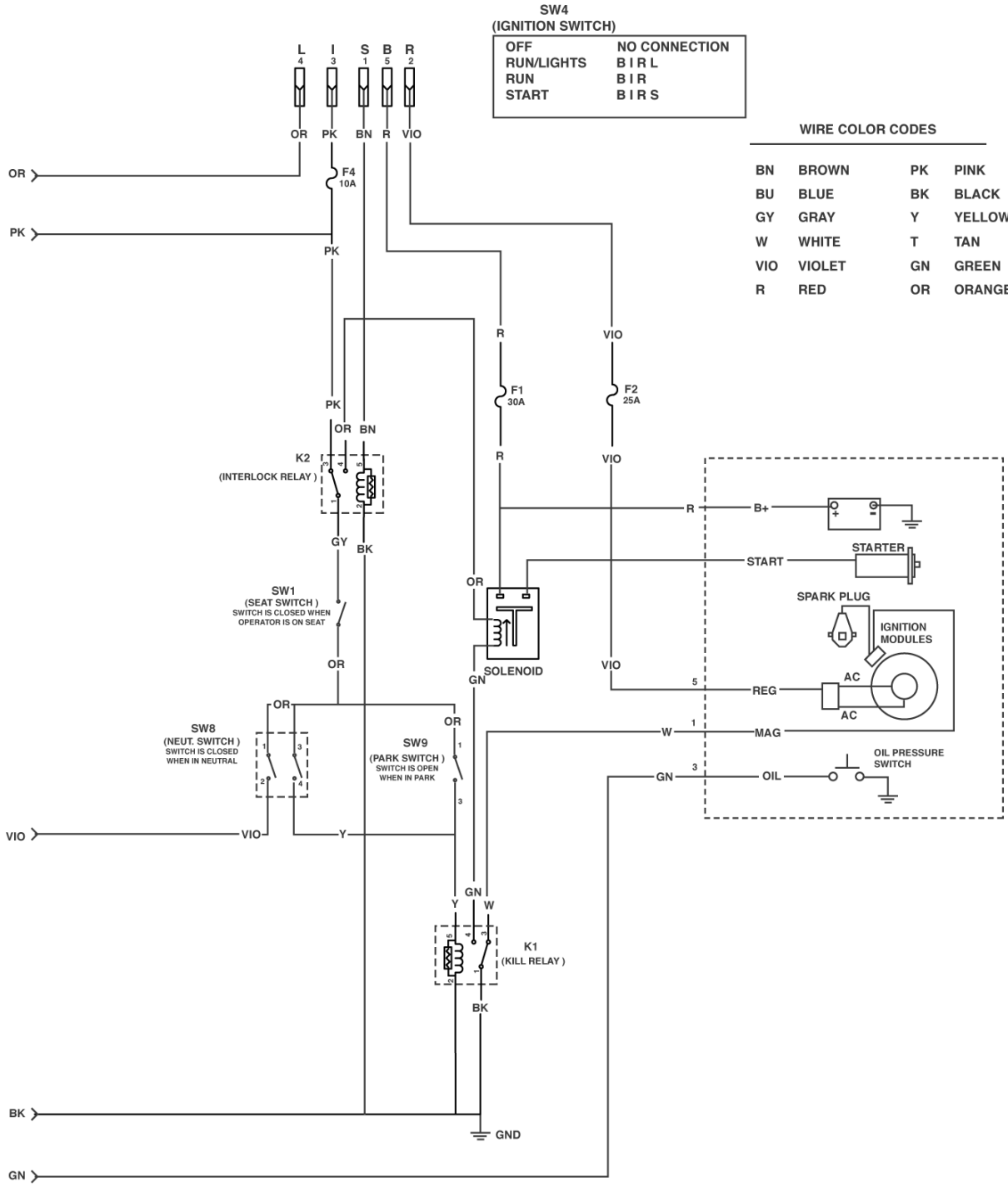

Wiring Diagram

**Starter Motor Circuit**  
(ignition switch in "start")

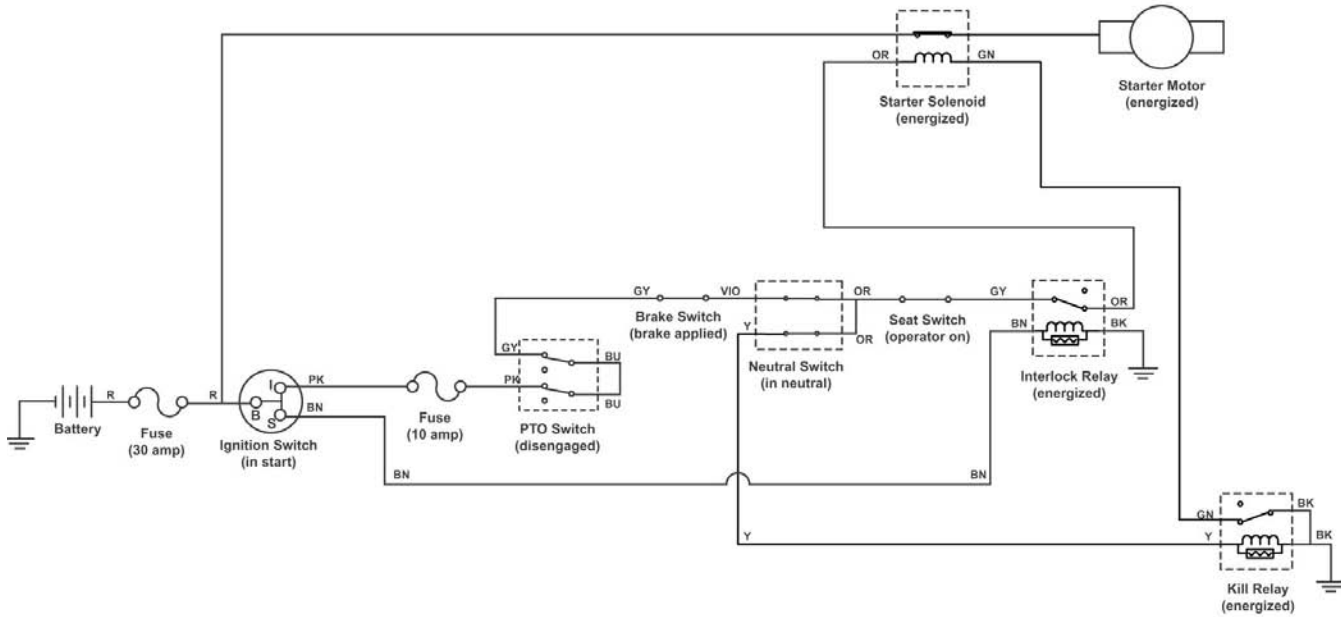

**Spark Circuit**  
(ignition switch in "start" position)

Legend	
Black	Bk
Blue	Bu
Brown	Bn
Green	Gn
Grey	Gy
Orange	Or
Pink	Pk
Red	Re
Tan	T
Violet	Vio
White	W
Yellow	Y

Dashed lines do not carry current

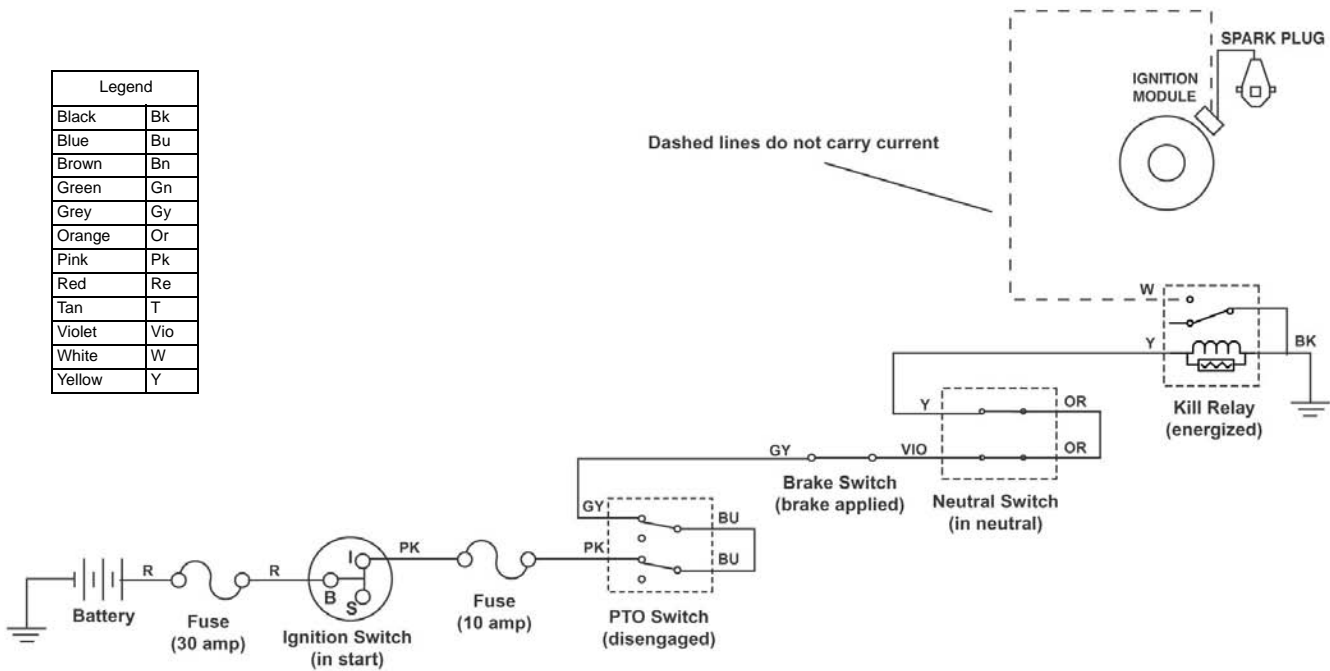

**Spark Circuit**  
(ignition switch in "run")

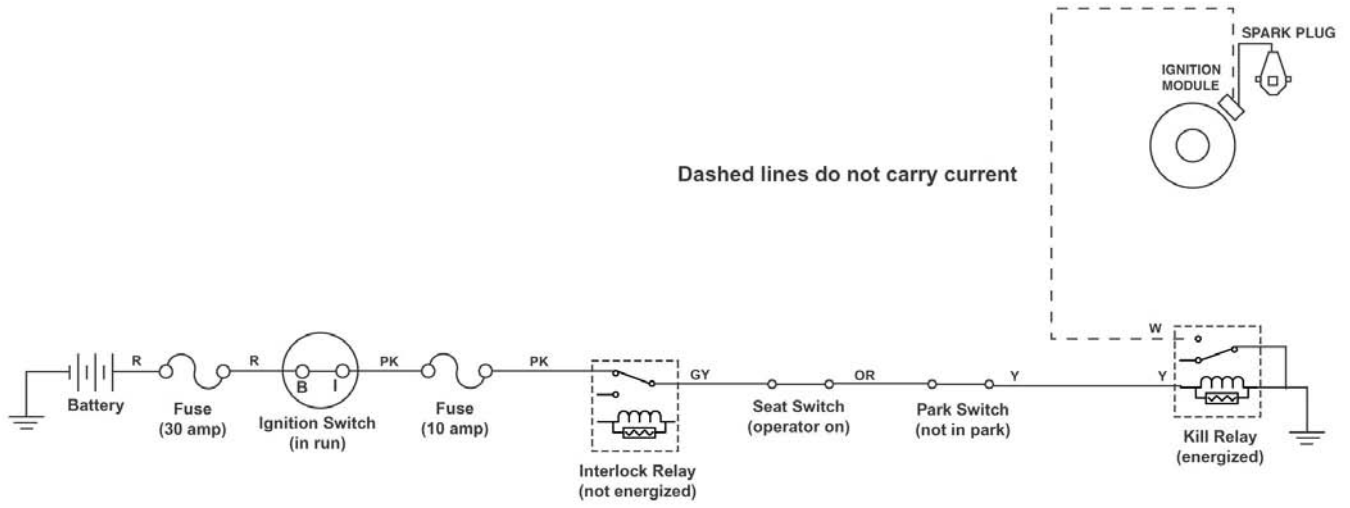

Legend	
Black	Bk
Blue	Bu
Brown	Bn
Green	Gn
Grey	Gy
Orange	Or
Pink	Pk
Red	Re
Tan	T
Violet	Vio
White	W
Yellow	Y

**Reverse Operating System Circuit**

(PTO "off", in forward)

Dashed lines do not carry current

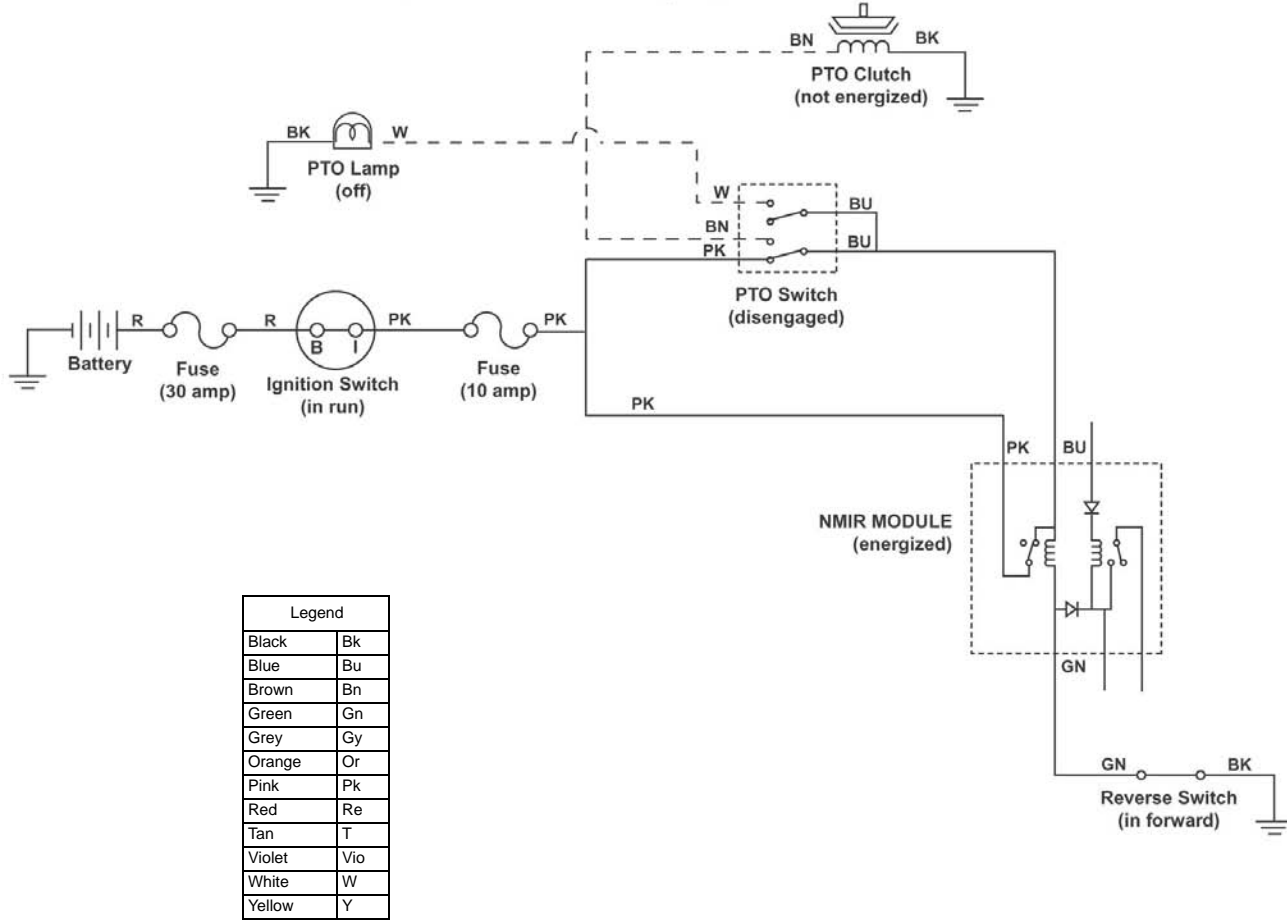

**Reverse Operating System Circuit**  
*(PTO "on", in forward)*

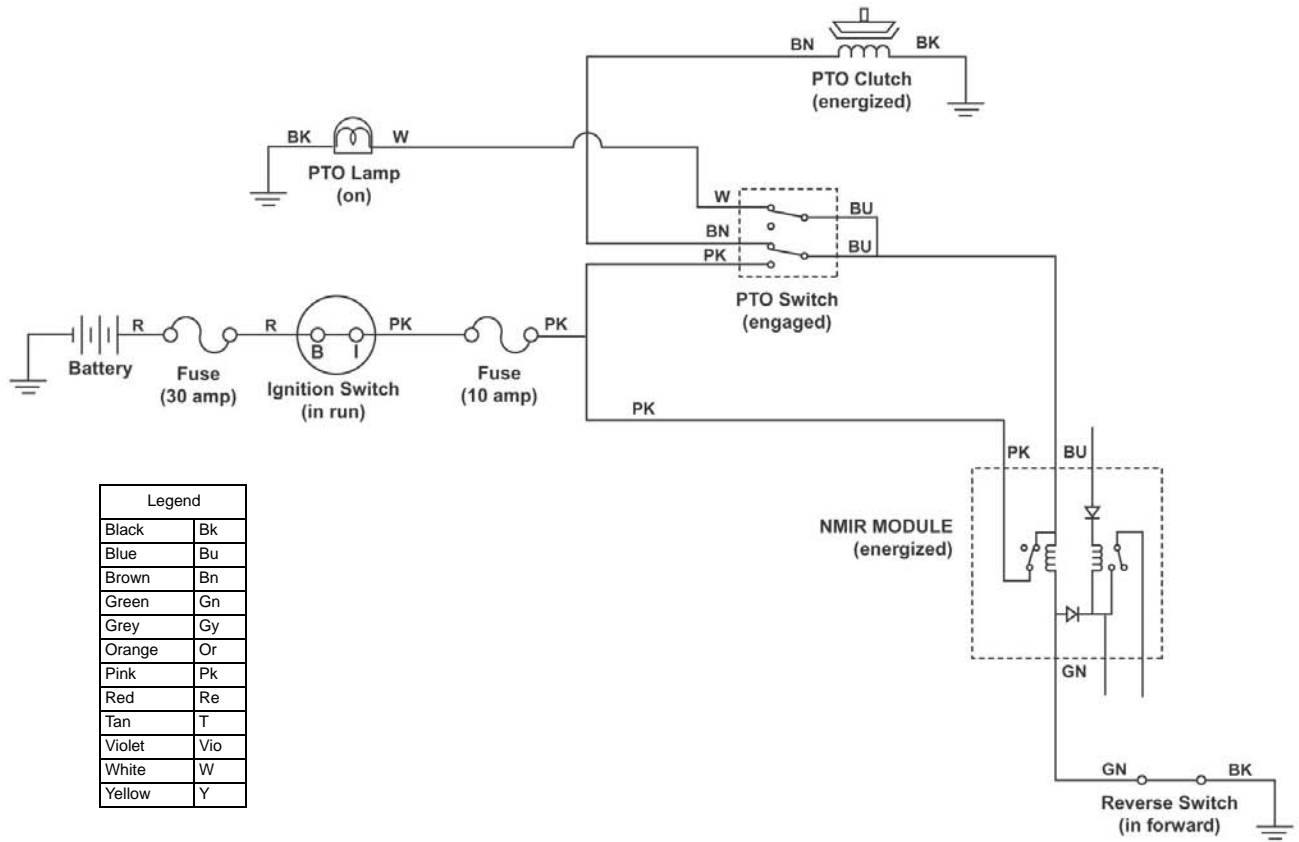

Legend	
Black	Bk
Blue	Bu
Brown	Bn
Green	Gn
Grey	Gy
Orange	Or
Pink	Pk
Red	Re
Tan	T
Violet	Vio
White	W
Yellow	Y

**Reverse Operating System Circuit**  
*(PTO "on", in reverse)*

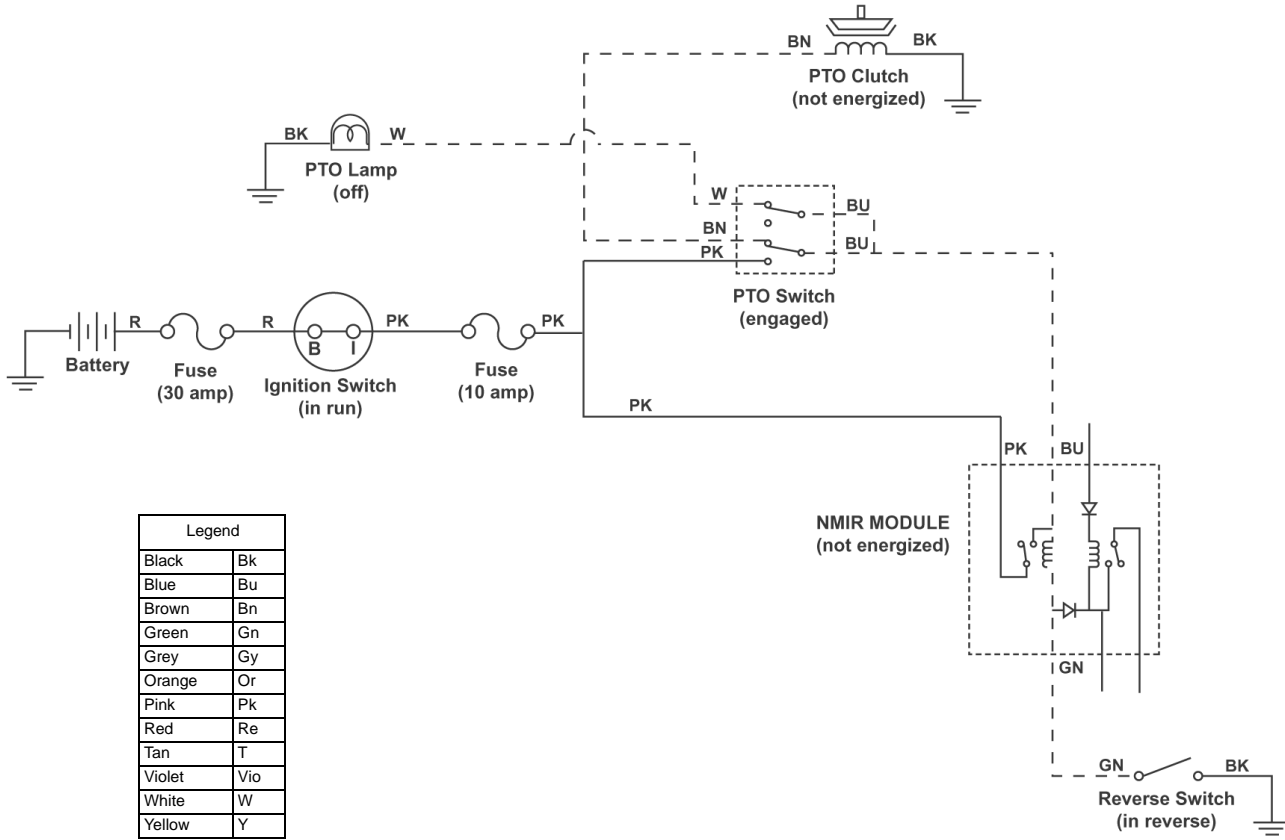

Legend	
Black	Bk
Blue	Bu
Brown	Bn
Green	Gn
Grey	Gy
Orange	Or
Pink	Pk
Red	Re
Tan	T
Violet	Vio
White	W
Yellow	Y



**Reverse Operating System Circuit**  
*(Override key switch "activated")*

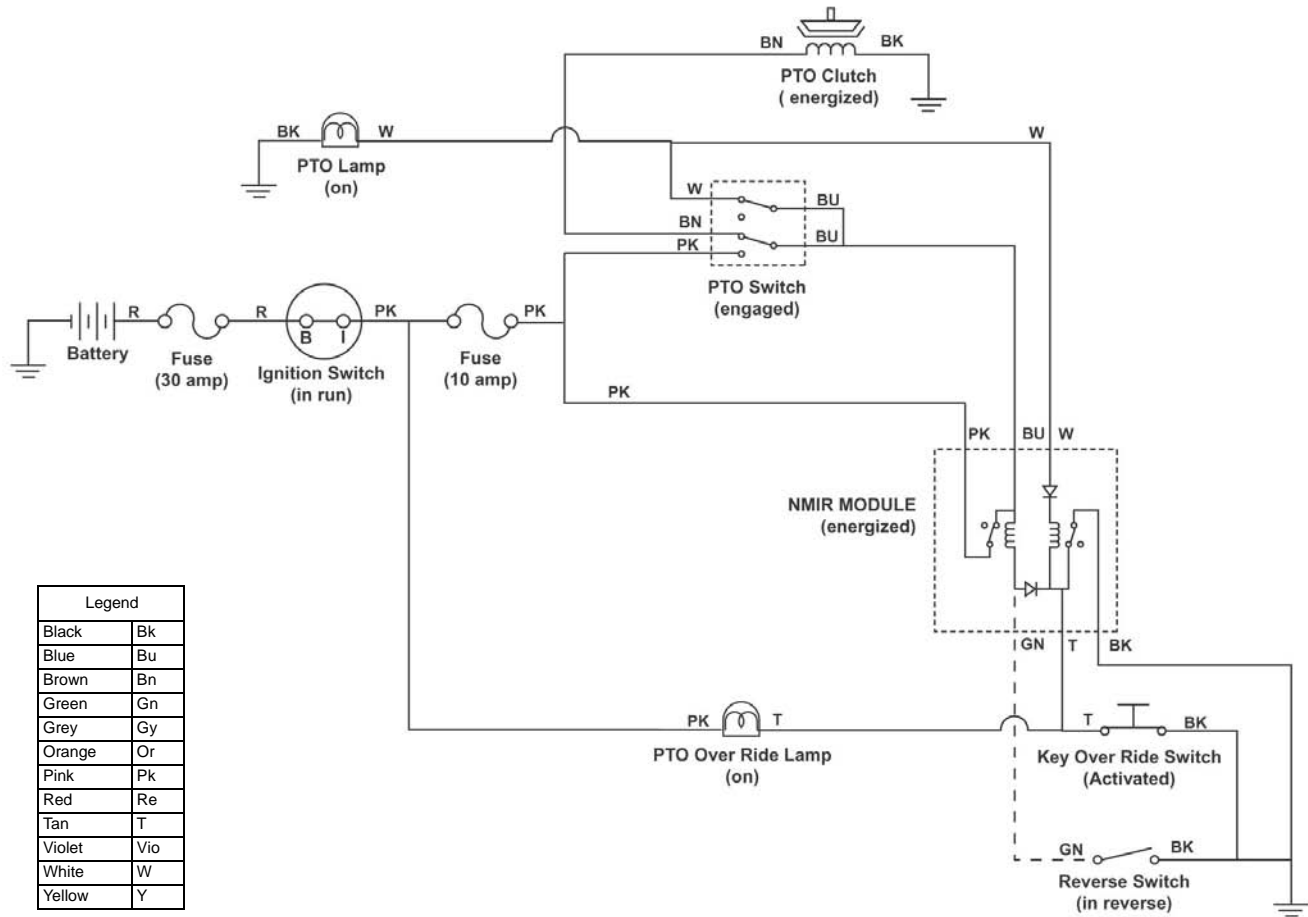

**Reverse Operating System Circuit**

*(PTO "on", in reverse, override mode)*

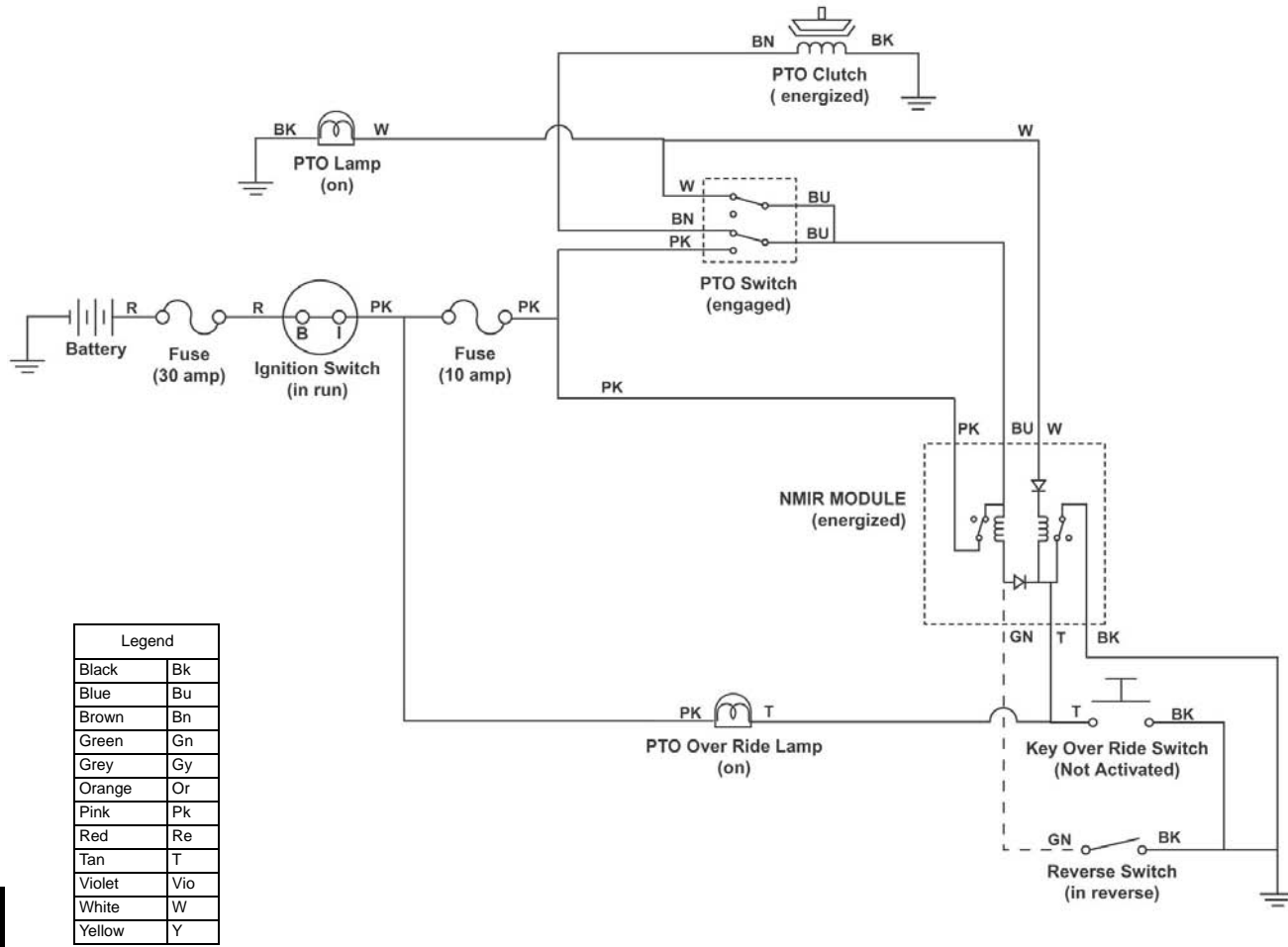

**Charging Circuit**  
(ignition switch in "run")

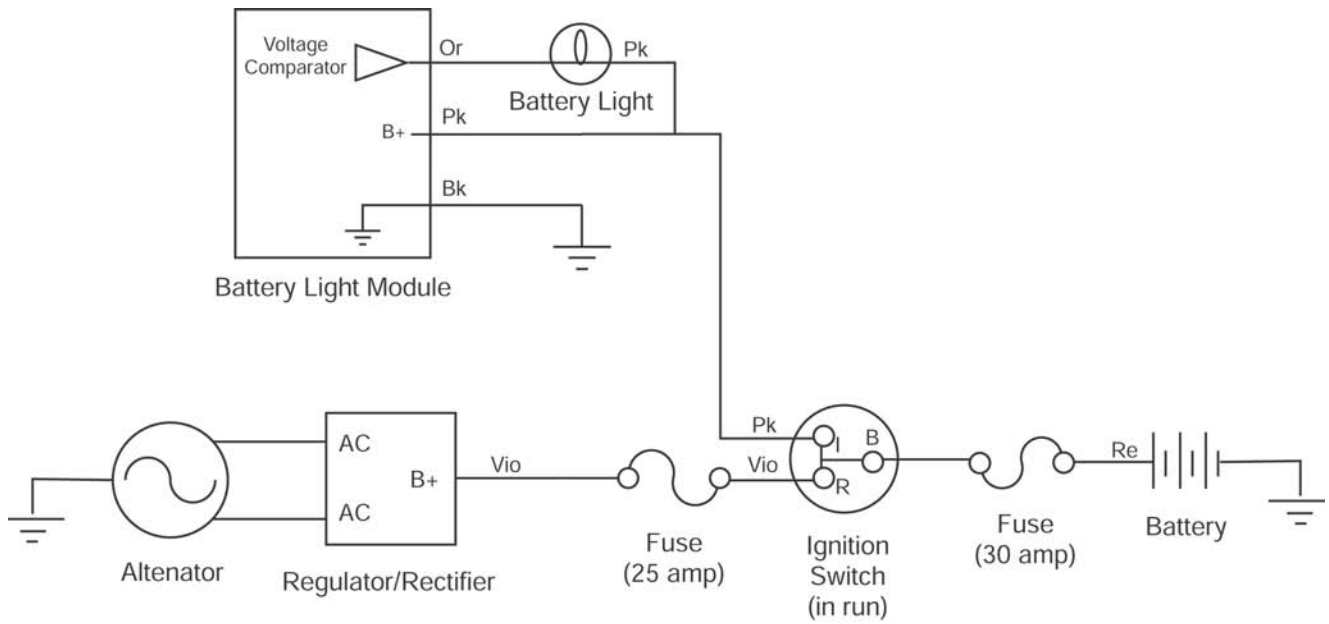

**Light Circuit**  
(ignition switch in "run/lights")

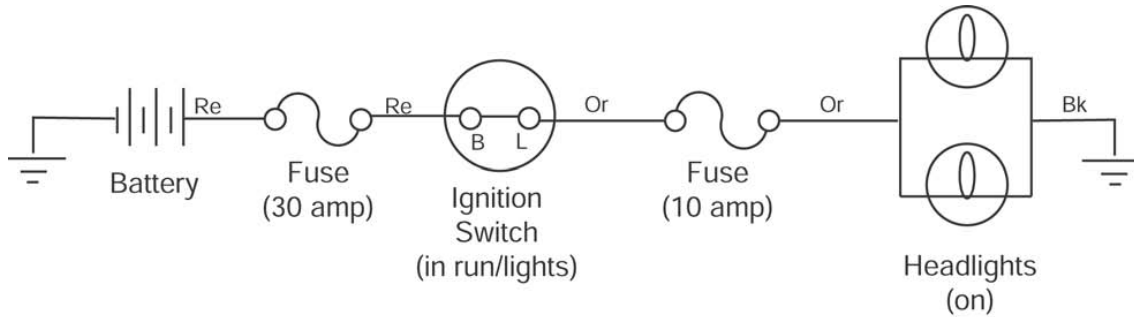

Legend	
Black	Bk
Blue	Bu
Brown	Bn
Green	Gn
Grey	Gy
Orange	Or
Pink	Pk
Red	Re
Tan	T
Violet	Vio
White	W
Yellow	Y

**Circuits**

**Hourmeter Circuit**  
(ignition switch in "run")

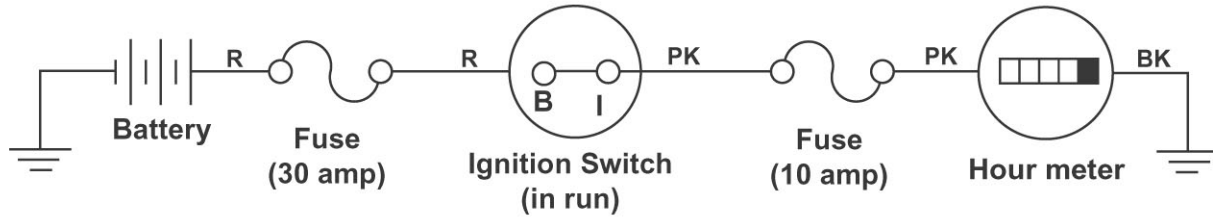

**Oil Pressure Light Circuit**  
(ignition switch in "run")

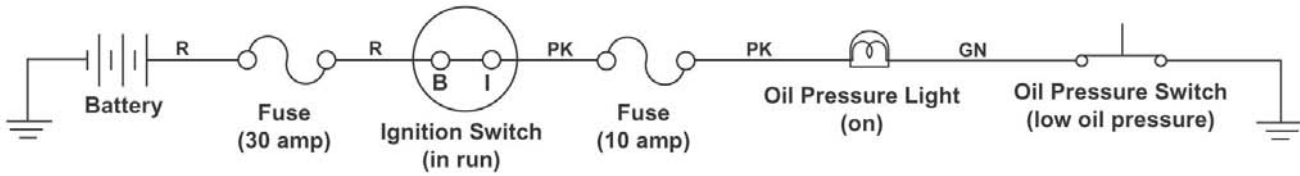

Legend	
Black	Bk
Blue	Bu
Brown	Bn
Green	Gn
Grey	Gy
Orange	Or
Pink	Pk
Red	Re
Tan	T
Violet	Vio
White	W
Yellow	Y



**268-H Information List (2002 - 2003)**

Wiring Diagrams . . . . . 8-2 & 8-3

Circuit Diagrams

- Starter Motor Circuit . . . . . 8-4
- Spark Circuits . . . . . 8-4 & 8-5
- Reverse Operating System Circuits . 8-6 - 8-10
- Cruise Control Circuit . . . . . 8-11
- Charging Circuit . . . . . 8-11
- Light Circuit . . . . . 8-12
- Hourmeter Circuit . . . . . 8-12
- Oil Pressure Light Circuit . . . . . 8-12



Wiring Diagram

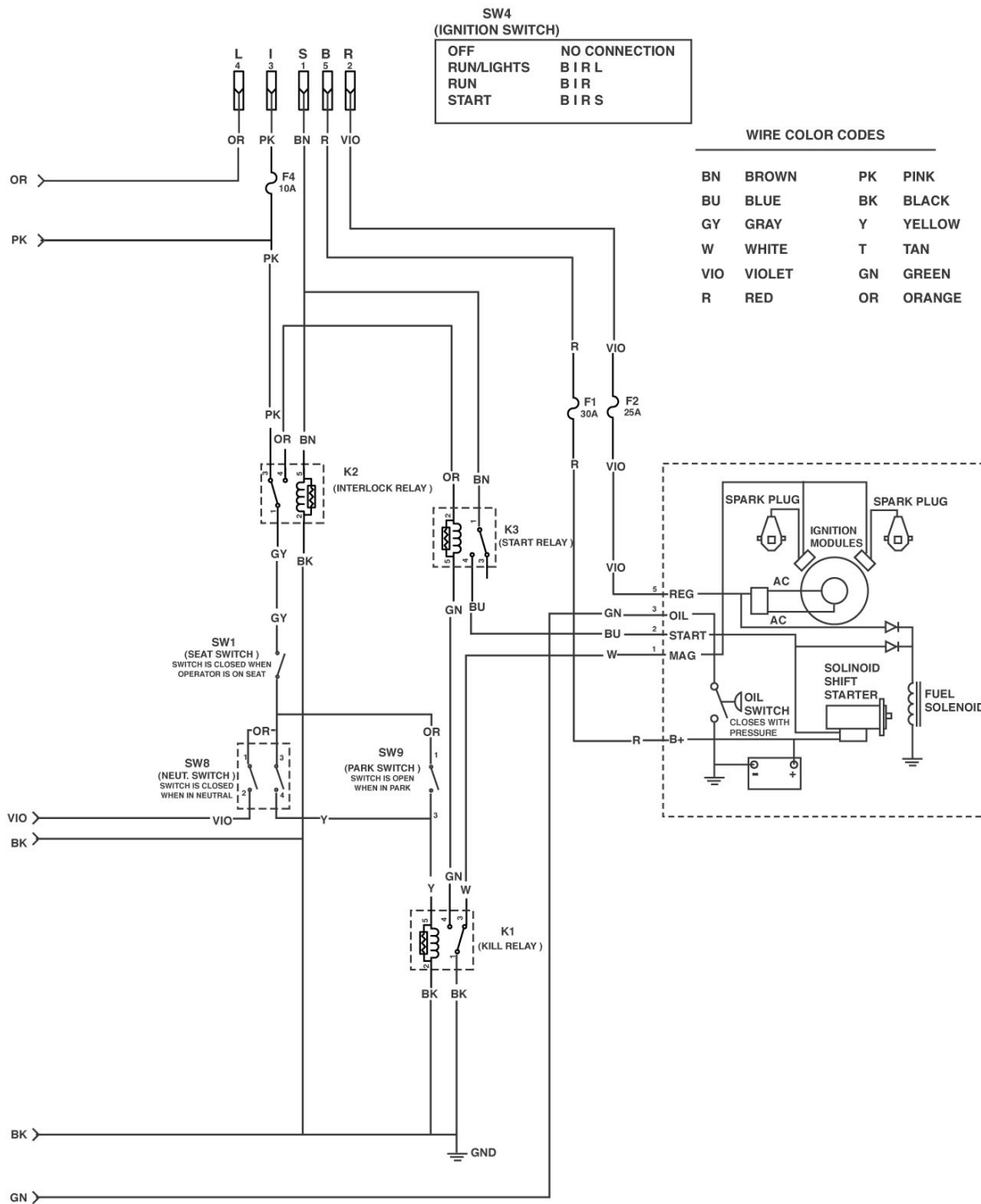

Wiring Diagram

**Starter Motor Circuit**  
(ignition switch in "start")

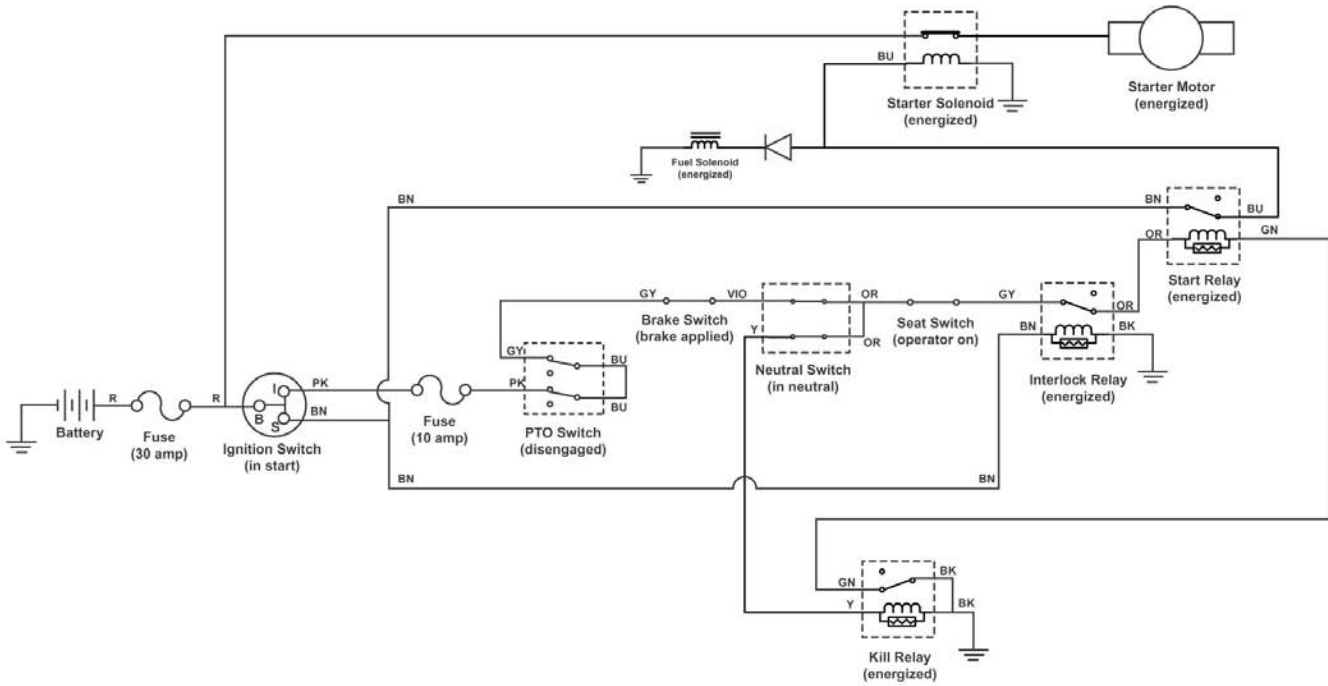

**Spark Circuit**  
(ignition switch in "start" position)

Legend	
Black	Bk
Blue	Bu
Brown	Bn
Green	Gn
Grey	Gy
Orange	Or
Pink	Pk
Red	Re
Tan	T
Violet	Vio
White	W
Yellow	Y

Dashed lines do not carry current

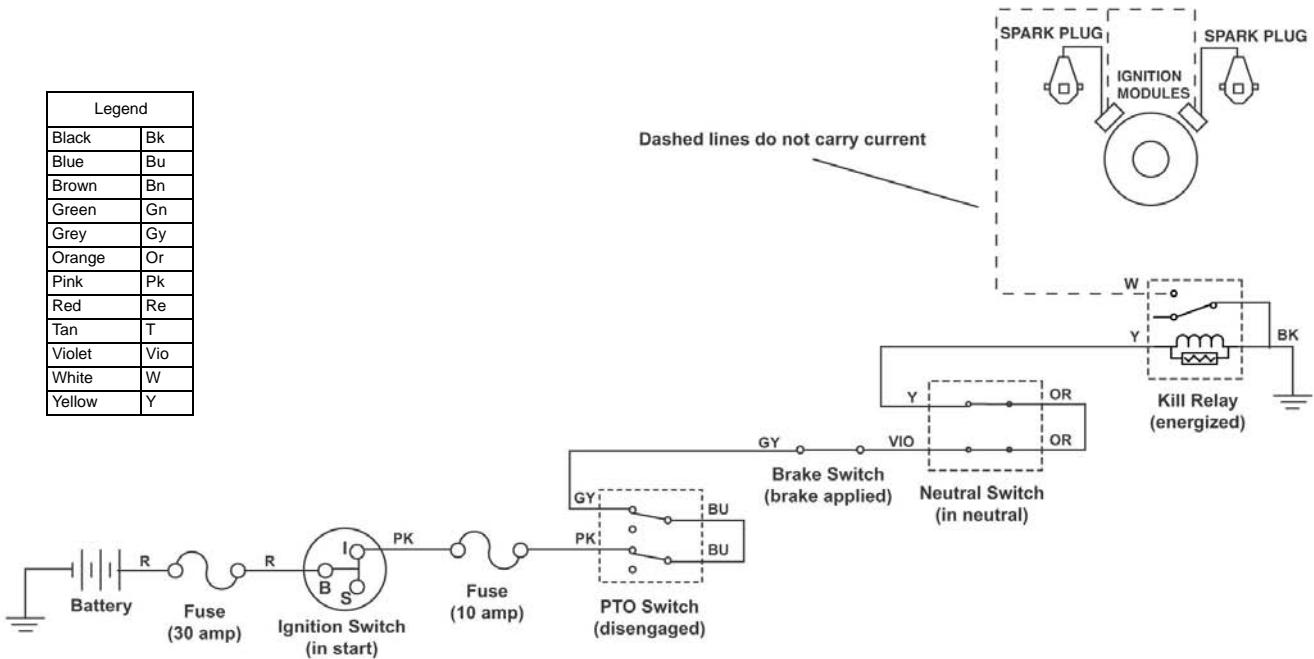



**Spark Circuit**  
(ignition switch in "run")

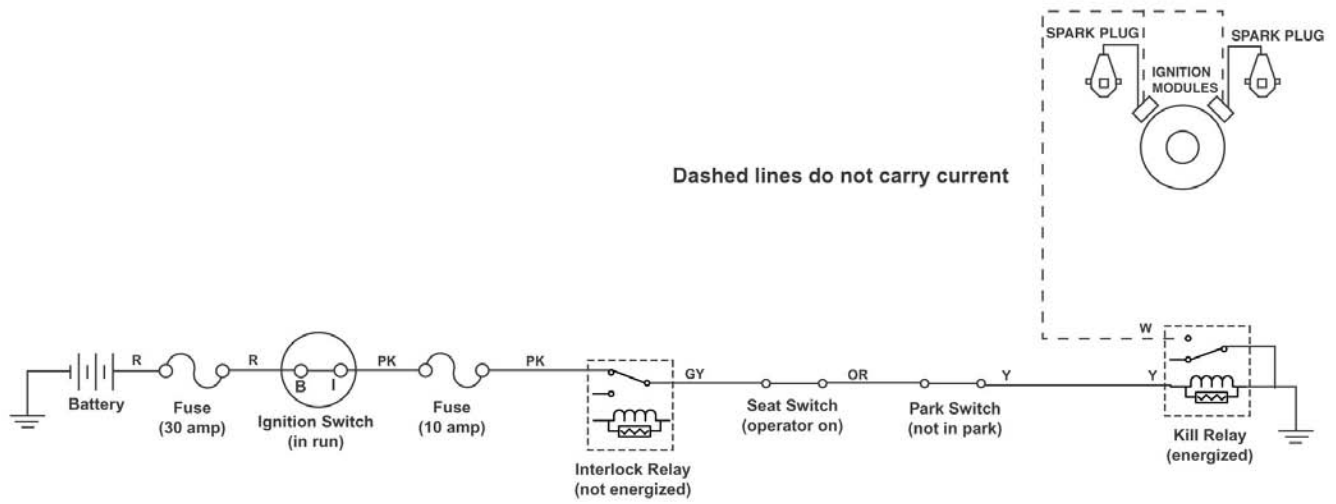

Legend	
Black	Bk
Blue	Bu
Brown	Bn
Green	Gn
Grey	Gy
Orange	Or
Pink	Pk
Red	Re
Tan	T
Violet	Vio
White	W
Yellow	Y

**Reverse Operating System Circuit**

*(PTO "off", in forward)*

Dashed lines do not carry current

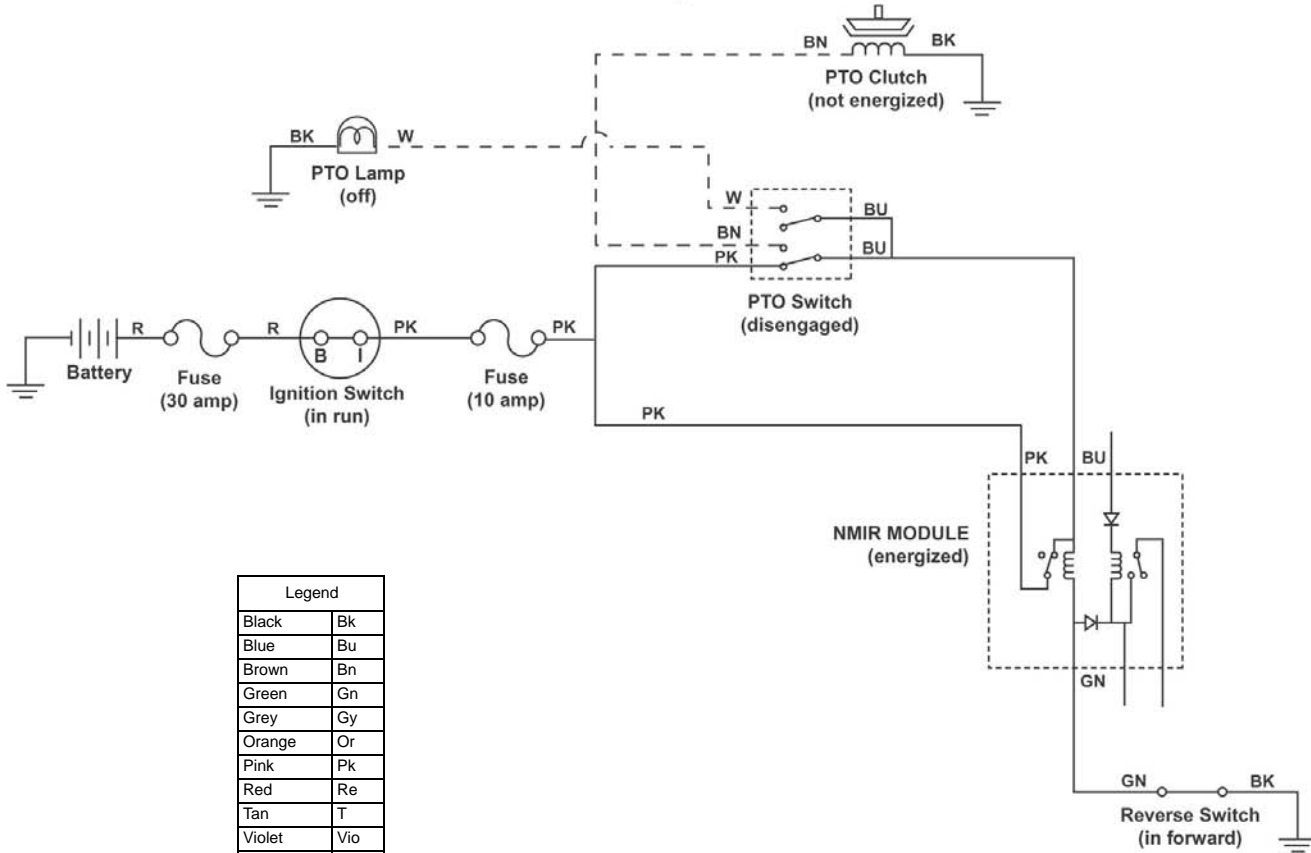

**Reverse Operating System Circuit**  
(PTO "on", in forward)

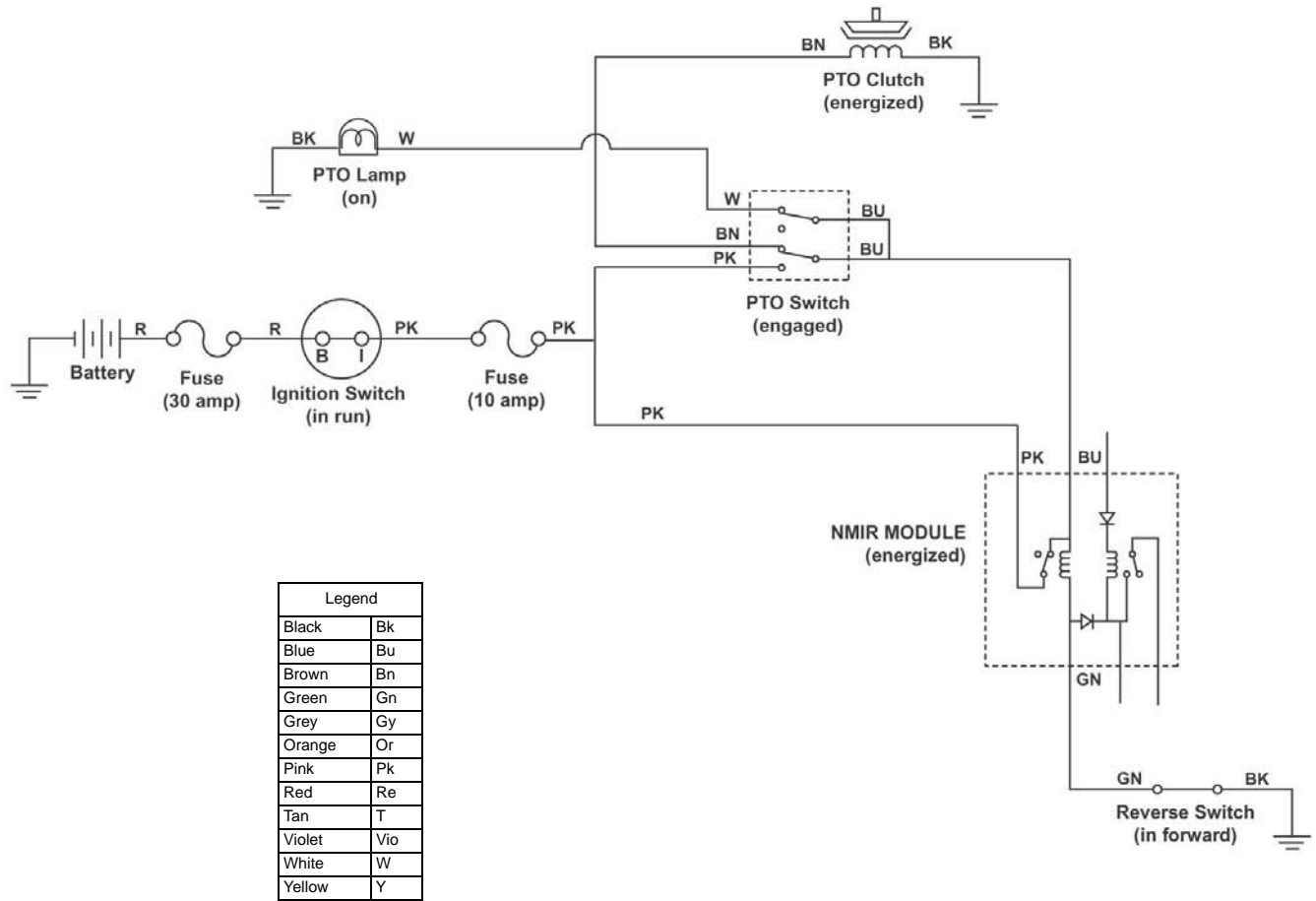

**Reverse Operating System Circuit**  
 (PTO "on", in reverse)

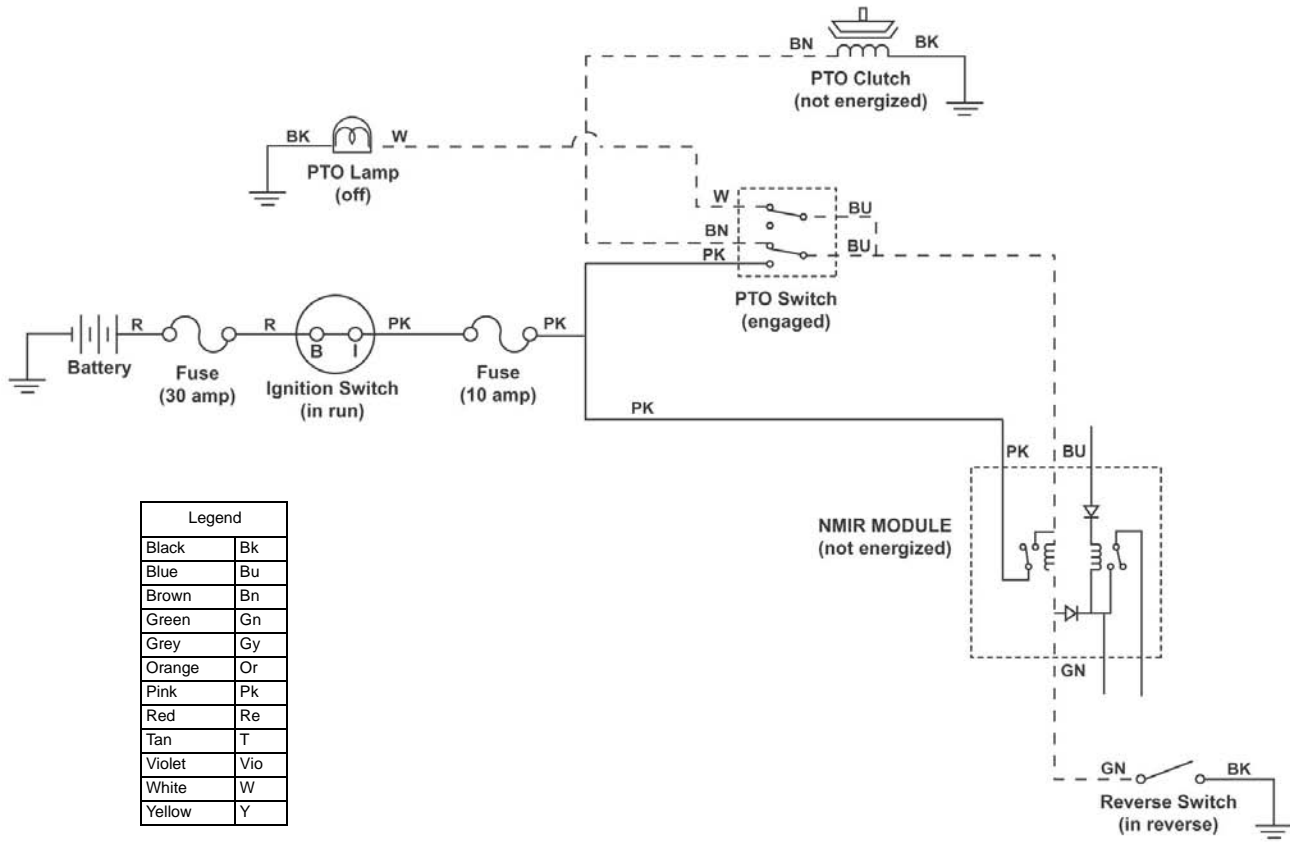

Legend	
Black	Bk
Blue	Bu
Brown	Bn
Green	Gn
Grey	Gy
Orange	Or
Pink	Pk
Red	Re
Tan	T
Violet	Vio
White	W
Yellow	Y

**Circuits**

**Reverse Operating System Circuit**  
(Override key switch "activated")

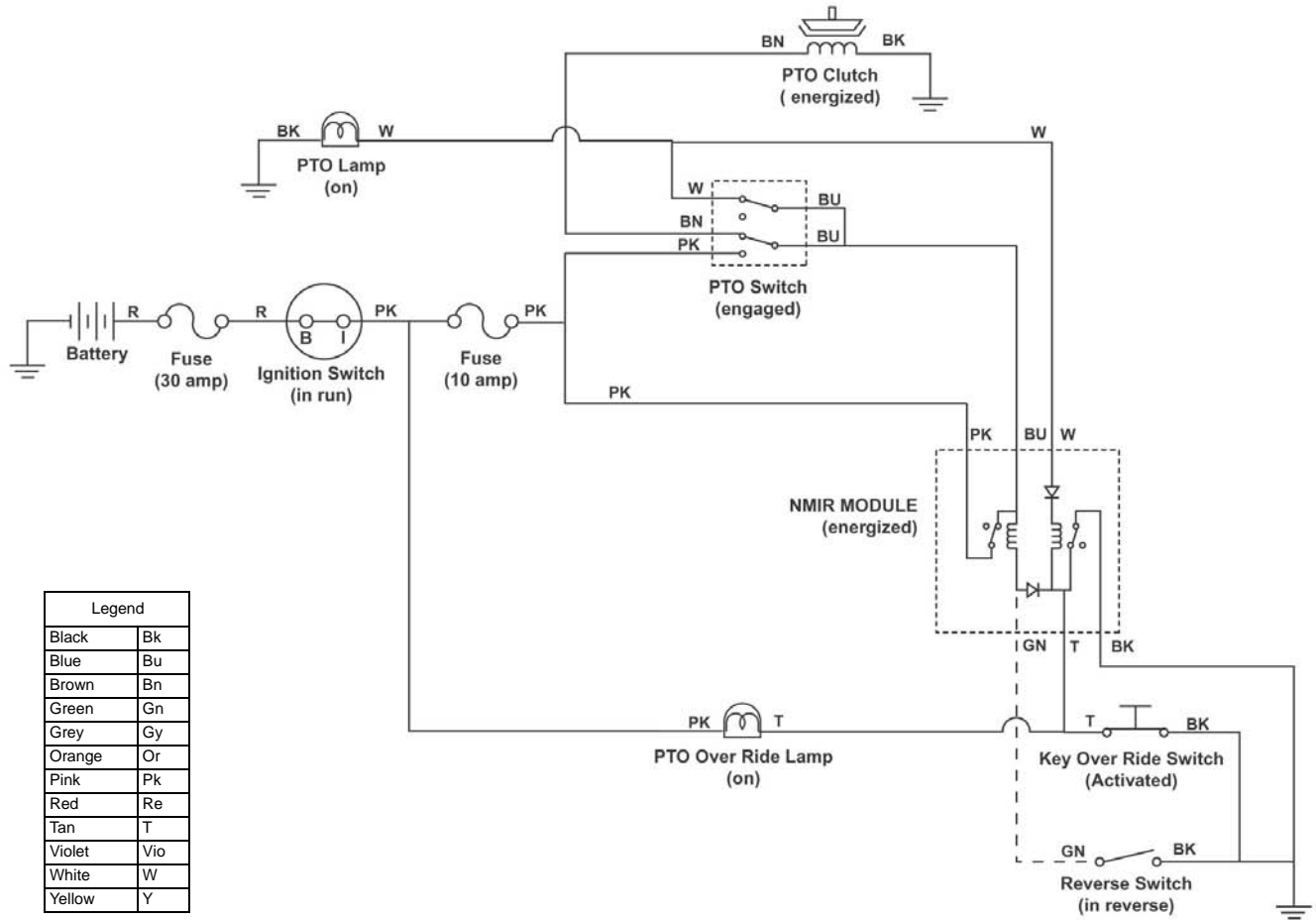

**Circuits**

**Reverse Operating System Circuit**

*(PTO "on", in reverse, override mode)*

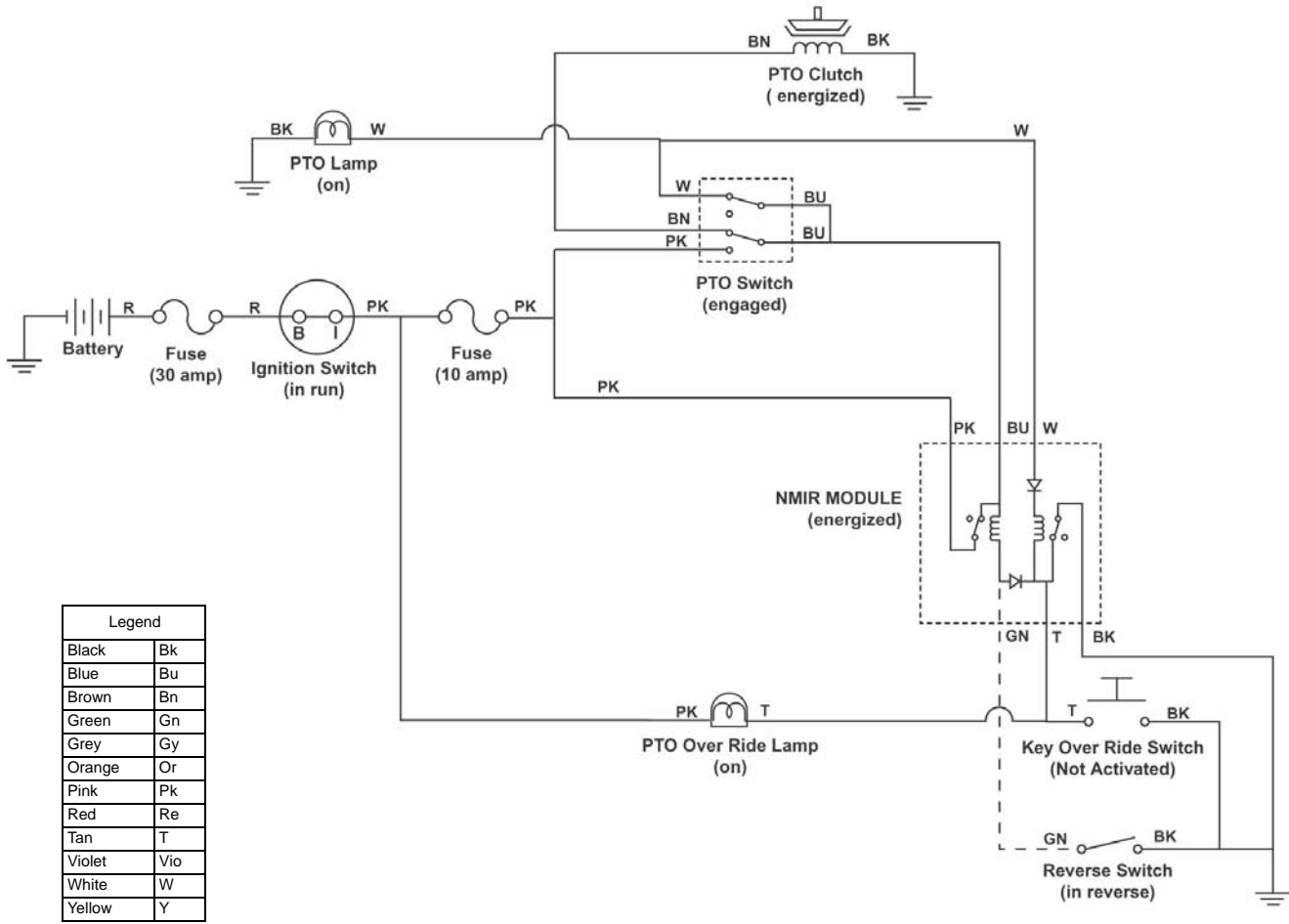

**Cruise Control Circuit**  
(ignition switch in "run")

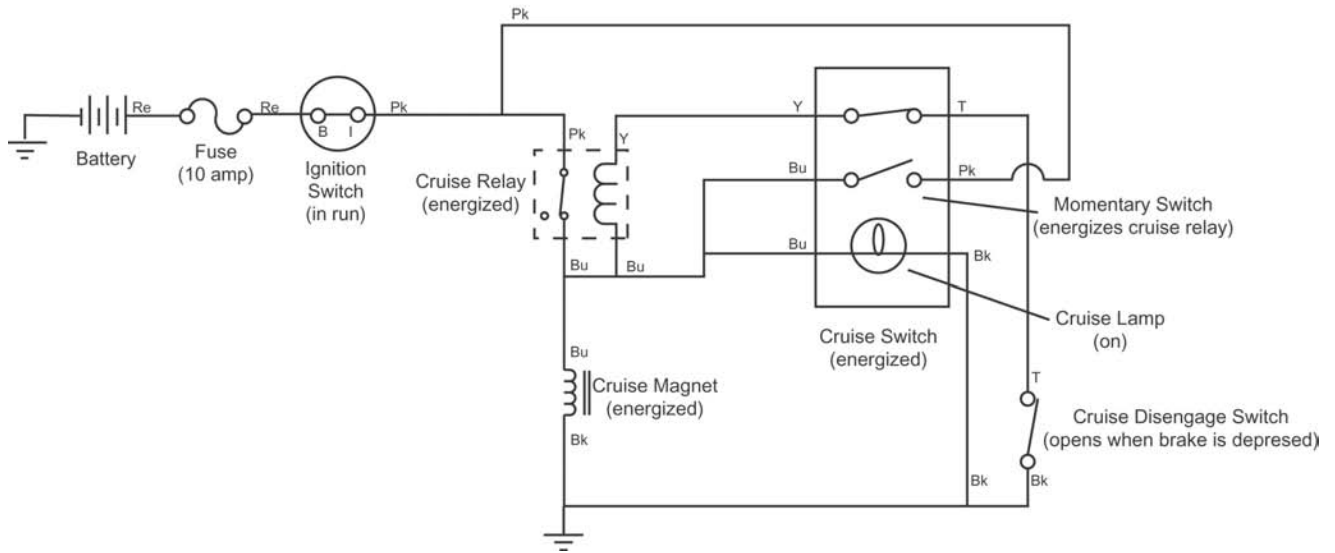

**Charging Circuit**  
(ignition switch in "run")

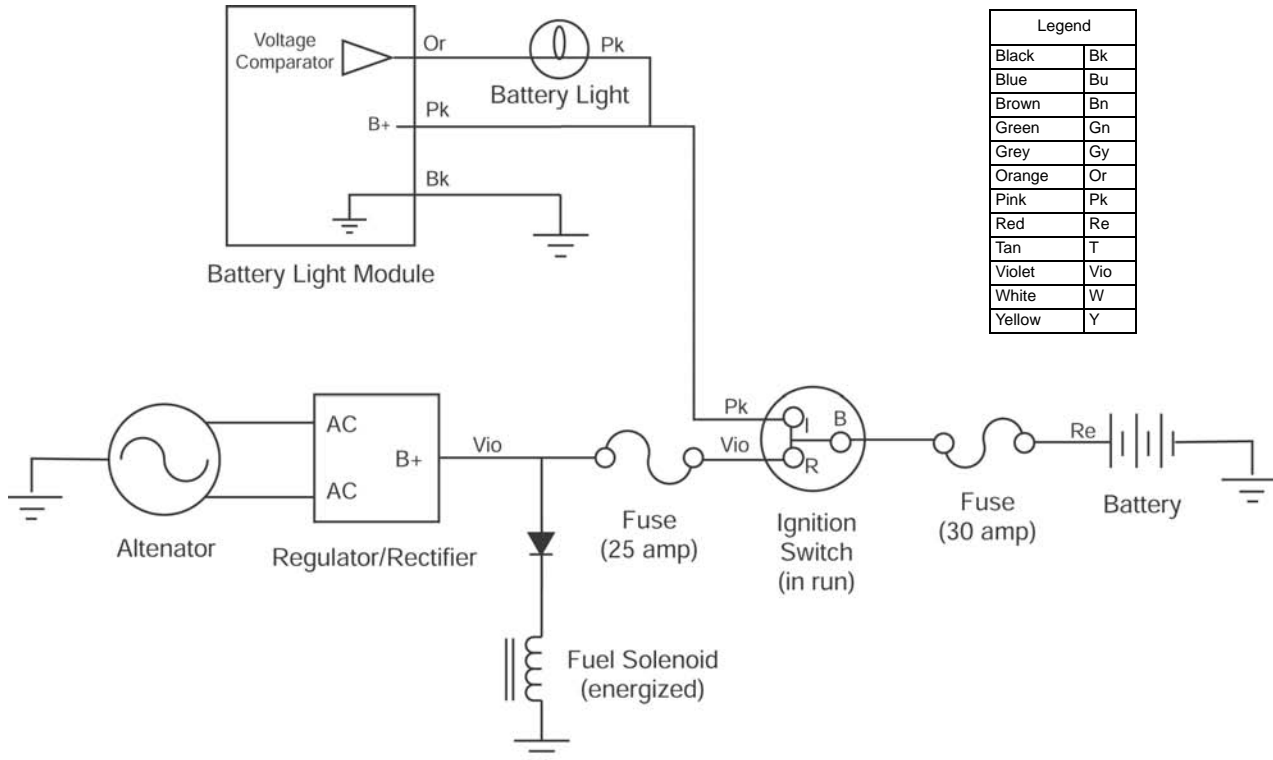

**Circuits**

**Light Circuit**

*(ignition switch in "run/lights")*

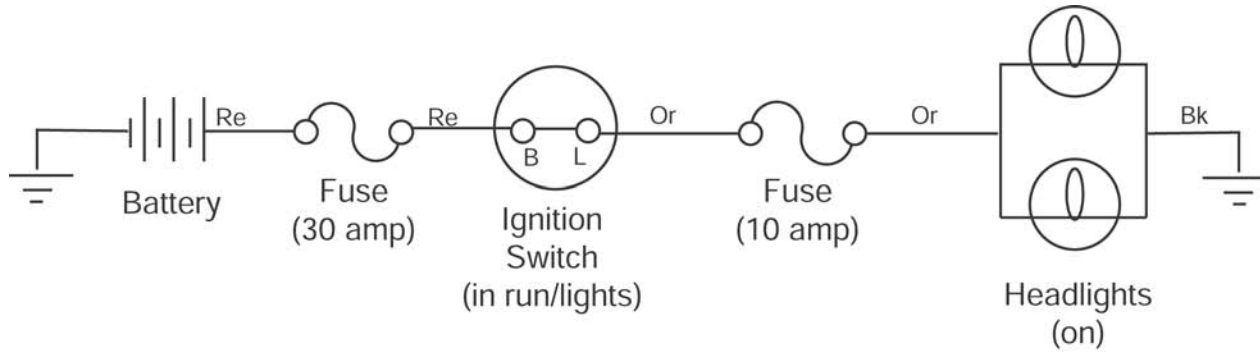

**Hourmeter Circuit**

*(ignition switch in "run")*

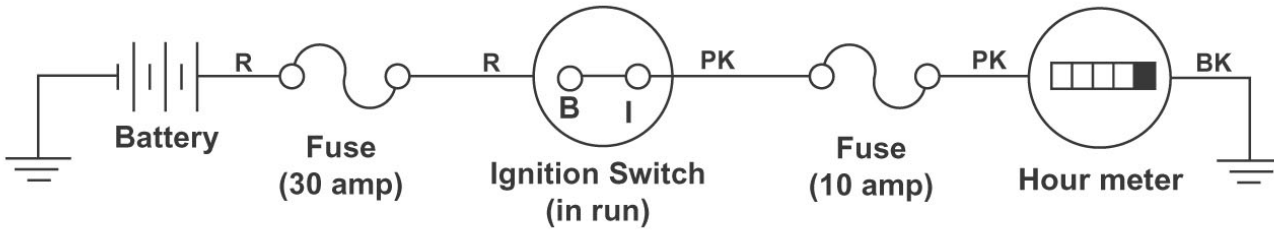

**Oil Pressure Light Circuit**

*(ignition switch in "run")*

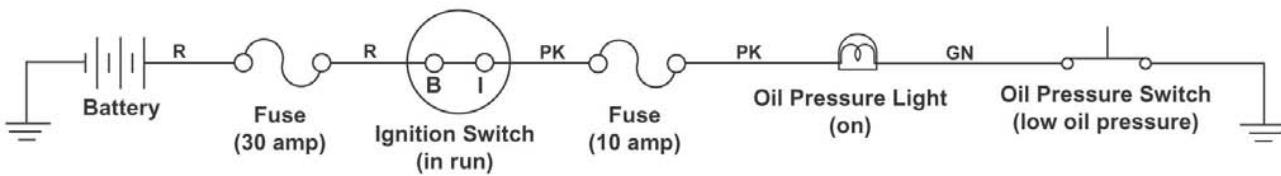

**Circuits**

Legend	
Black	Bk
Blue	Bu
Brown	Bn
Green	Gn
Grey	Gy
Orange	Or
Pink	Pk
Red	Re
Tan	T
Violet	Vio
White	W
Yellow	Y





**270-H Information List (2002 - 2003)**

Wiring Diagrams . . . . . 9-2 & 9-3

Circuit Diagrams

- Starter Motor Circuit . . . . . 9-4
- Spark Circuits . . . . . 9-4 & 9-5
- Reverse Operating System Circuits . . 9-6 - 9-10
- Cruise Control Circuit . . . . . 9-11
- Charging Circuit . . . . . 9-11
- Light Circuit . . . . . 9-12
- Hourmeter Circuit . . . . . 9-12
- Oil Pressure Light Circuit . . . . . 9-12
- Lift Pump Circuit . . . . . 9-13
- Engine Temperature Light Circuit . . . . . 9-13



Wiring Diagram

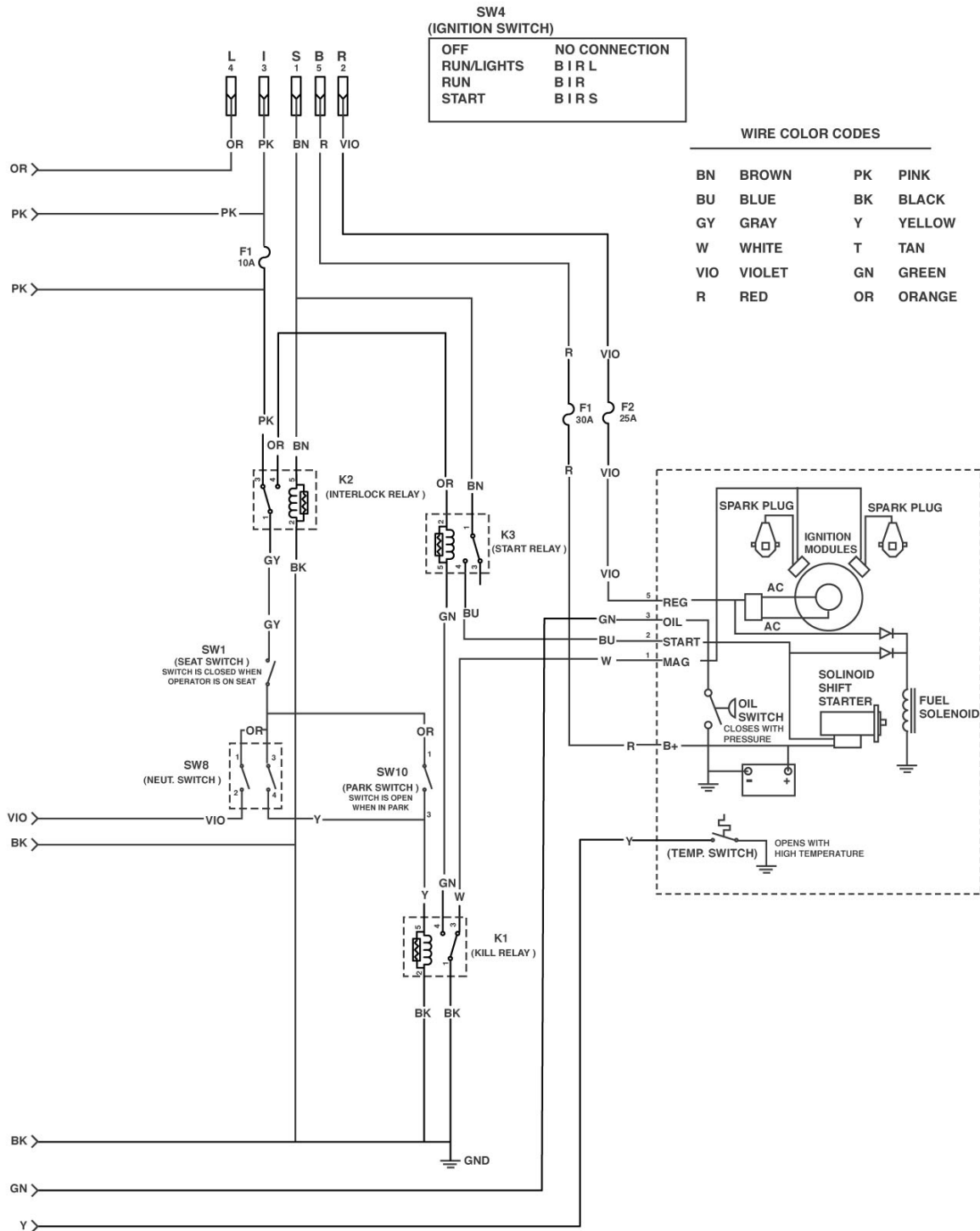

Wiring Diagram

**Starter Motor Circuit**  
(ignition switch in "start")

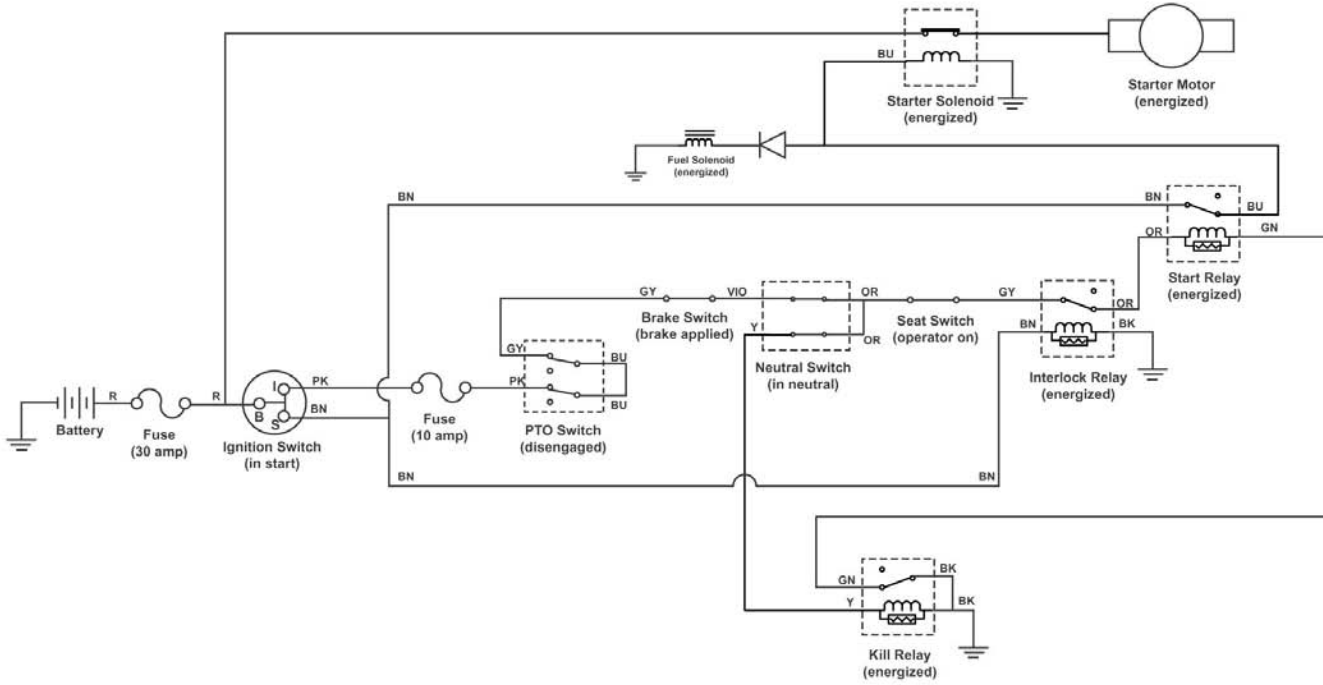

**Spark Circuit**  
(ignition switch in "start" position)

Legend	
Black	Bk
Blue	Bu
Brown	Bn
Green	Gn
Grey	Gy
Orange	Or
Pink	Pk
Red	Re
Tan	T
Violet	Vio
White	W
Yellow	Y

Dashed lines do not carry current

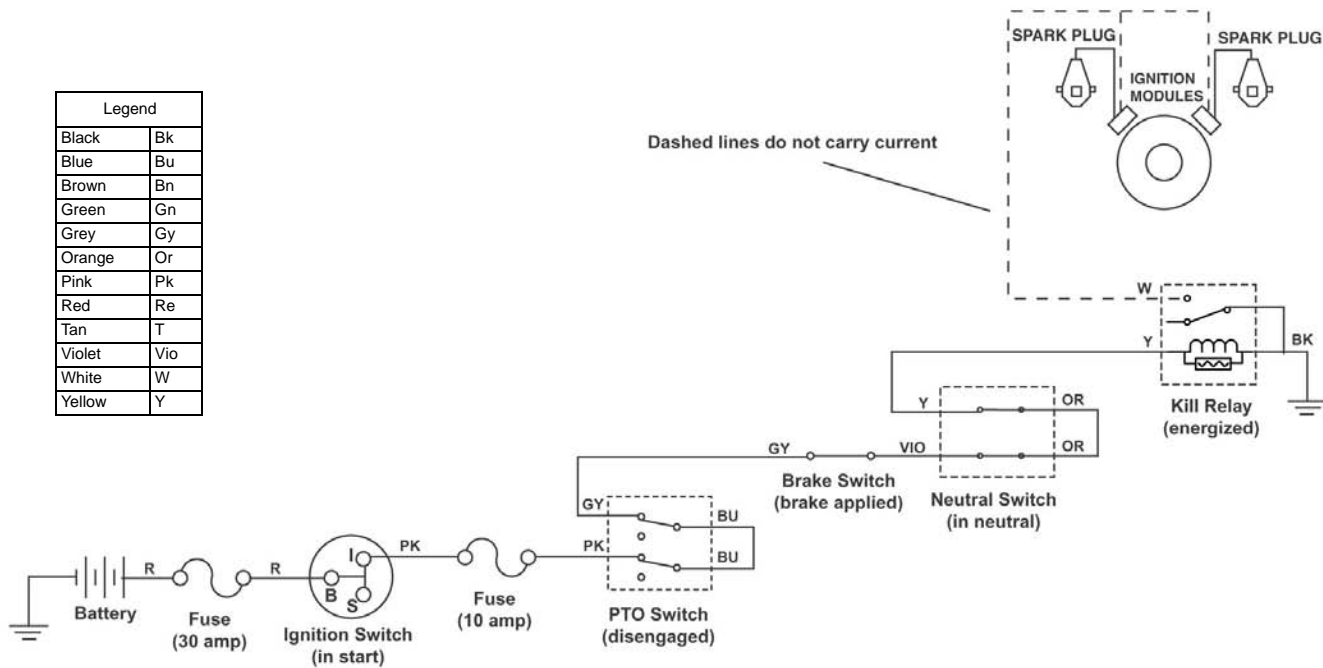

**Spark Circuit**  
(ignition switch in "run")

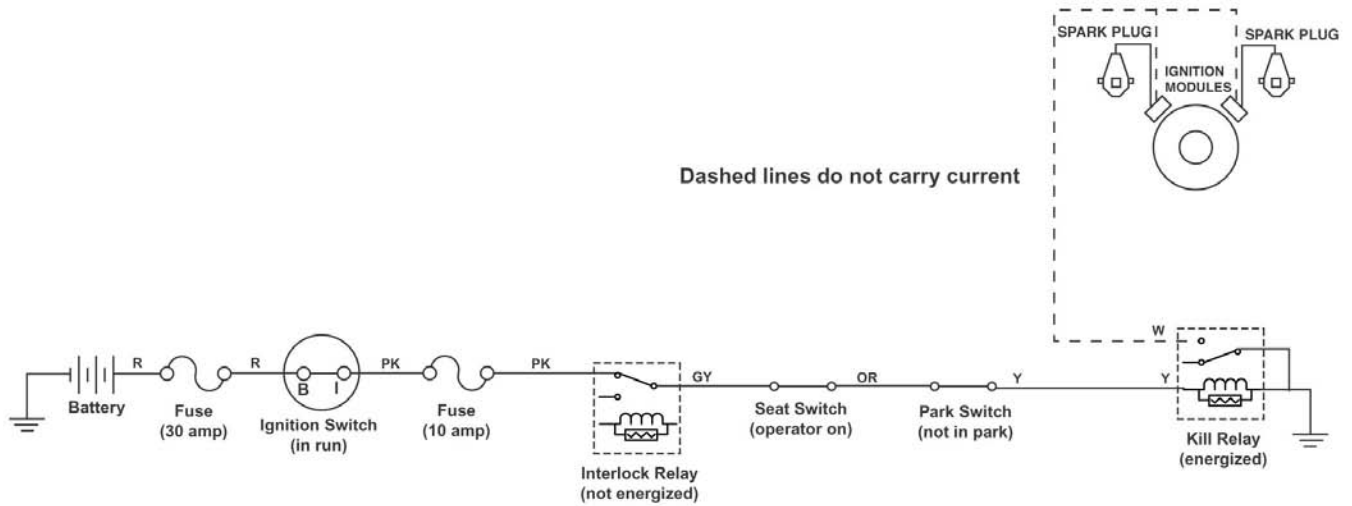

Legend	
Black	Bk
Blue	Bu
Brown	Bn
Green	Gn
Grey	Gy
Orange	Or
Pink	Pk
Red	Re
Tan	T
Violet	Vio
White	W
Yellow	Y

**Reverse Operating System Circuit**  
 (PTO "off", in forward)

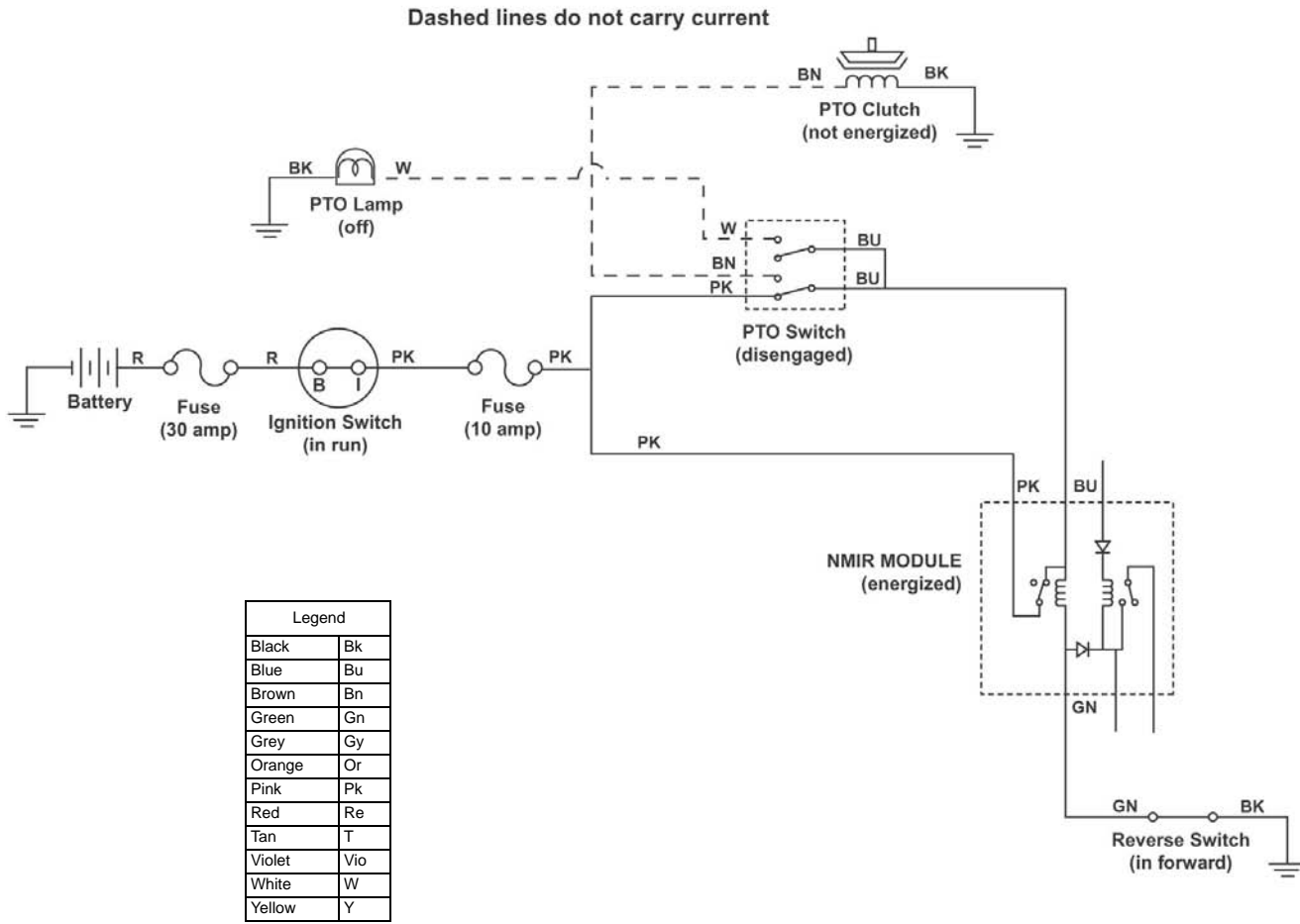

**Circuits**

**Reverse Operating System Circuit**  
(PTO "on", in forward)

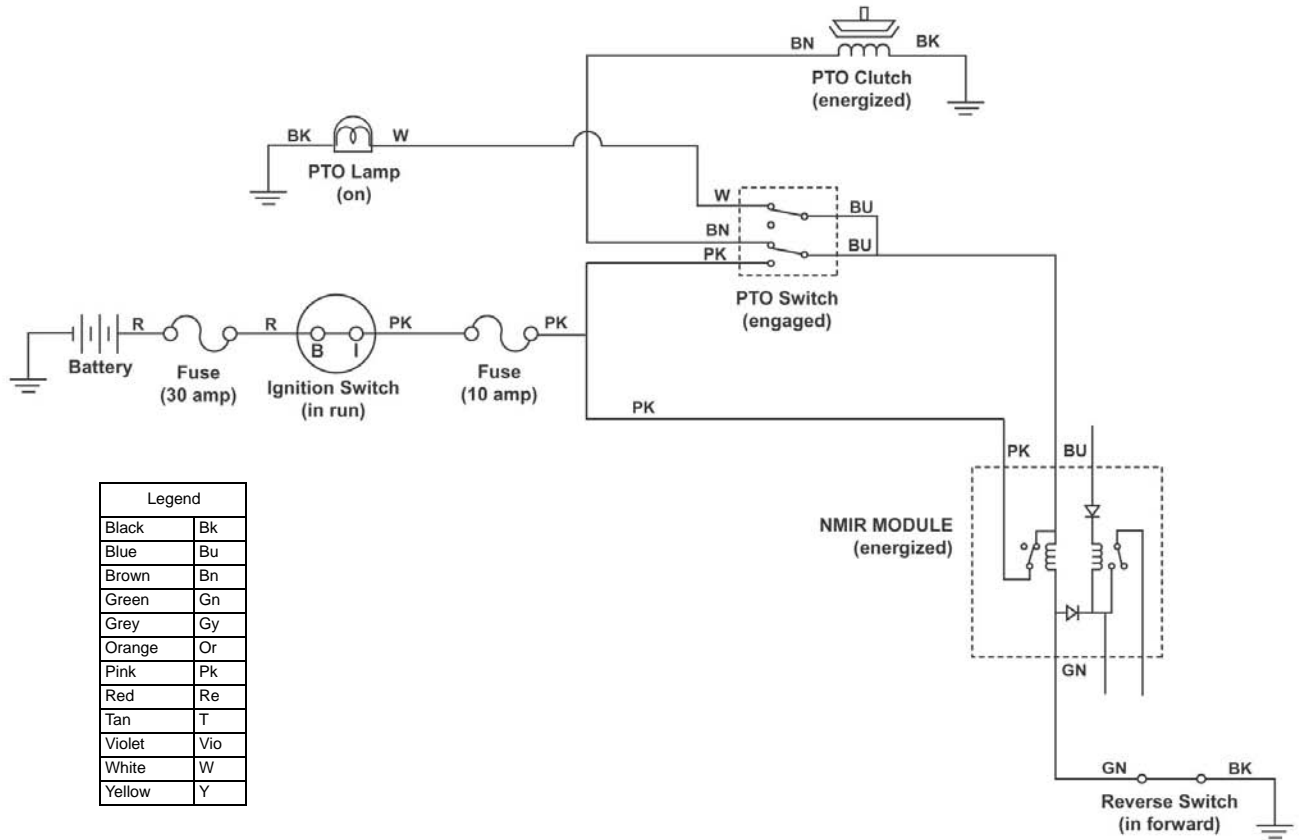

Legend	
Black	Bk
Blue	Bu
Brown	Bn
Green	Gn
Grey	Gy
Orange	Or
Pink	Pk
Red	Re
Tan	T
Violet	Vio
White	W
Yellow	Y

**Reverse Operating System Circuit**

(PTO "on", in reverse)

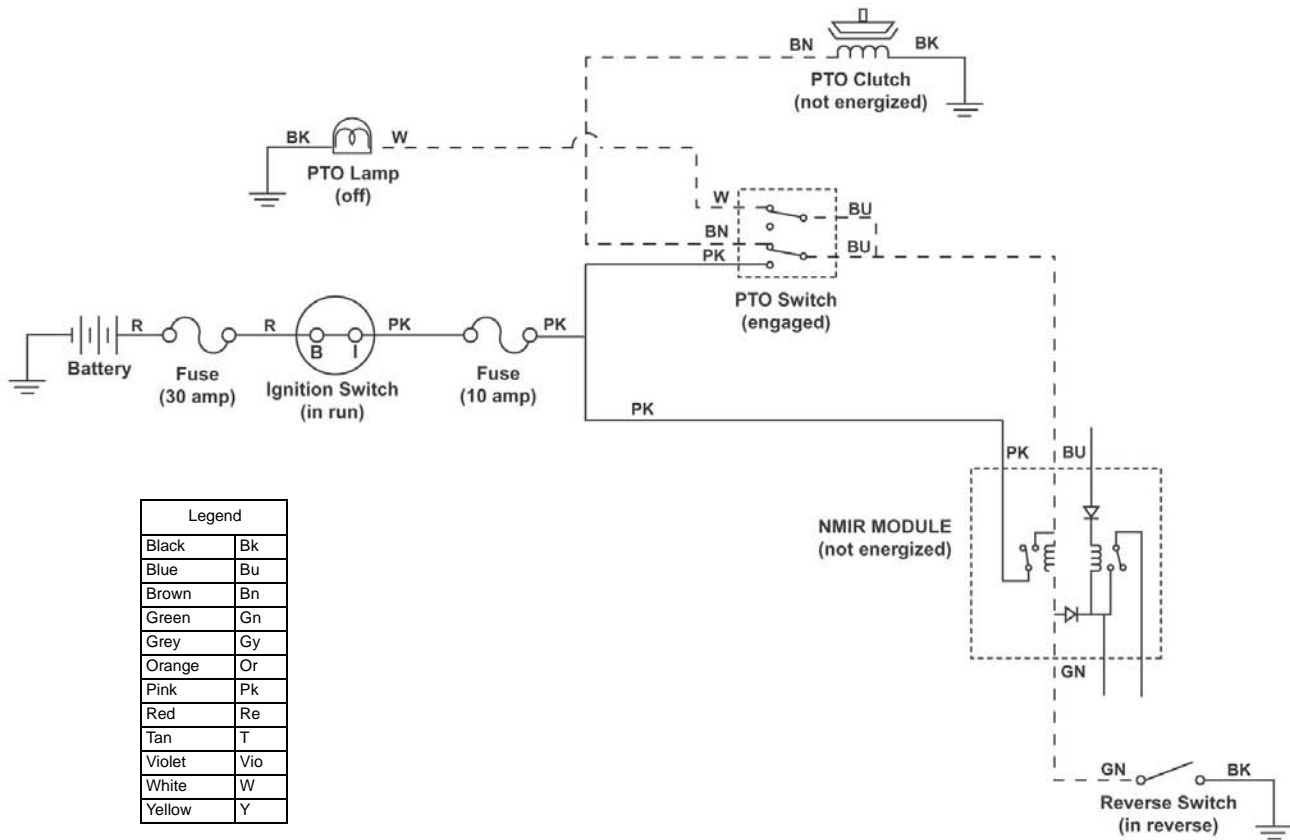

Legend	
Black	Bk
Blue	Bu
Brown	Bn
Green	Gn
Grey	Gy
Orange	Or
Pink	Pk
Red	Re
Tan	T
Violet	Vio
White	W
Yellow	Y

**Circuits**



**Reverse Operating System Circuit**  
(Override key switch "activated")

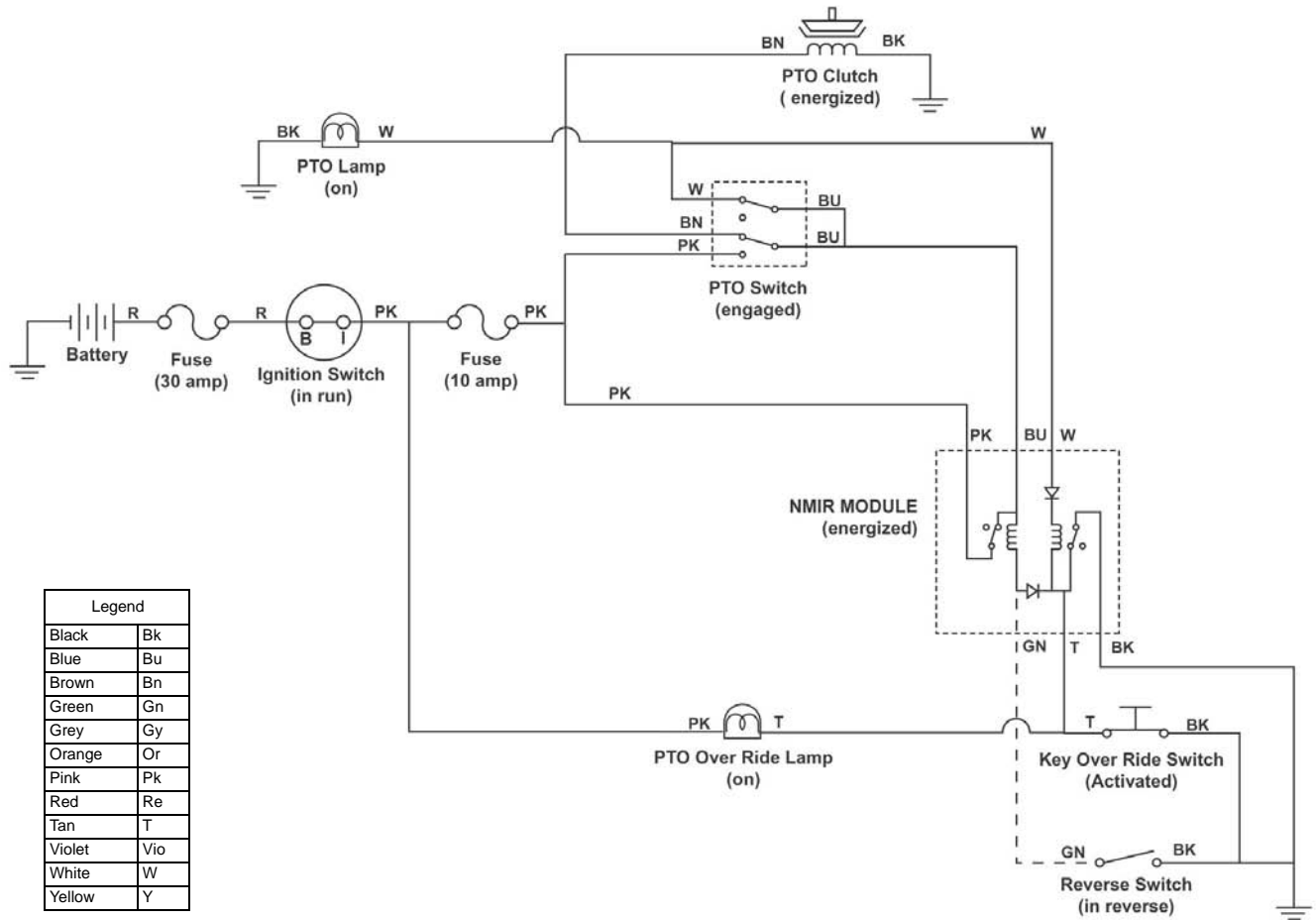

Legend	
Black	Bk
Blue	Bu
Brown	Bn
Green	Gn
Grey	Gy
Orange	Or
Pink	Pk
Red	Re
Tan	T
Violet	Vio
White	W
Yellow	Y

**Circuits**

**Reverse Operating System Circuit**  
 (PTO "on", in reverse, override mode)

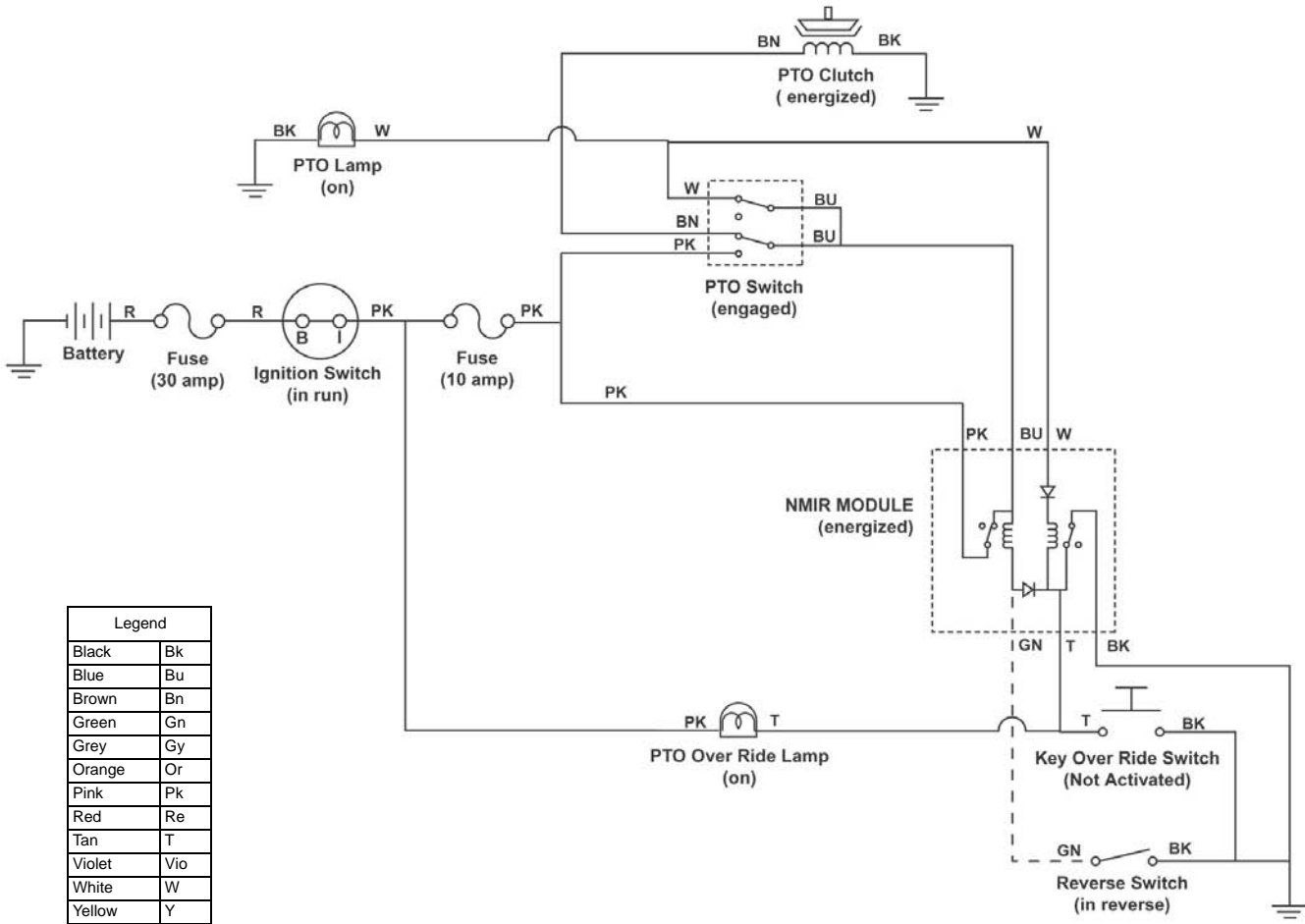

Legend	
Black	Bk
Blue	Bu
Brown	Bn
Green	Gn
Grey	Gy
Orange	Or
Pink	Pk
Red	Re
Tan	T
Violet	Vio
White	W
Yellow	Y

**Cruise Control Circuit**  
(ignition switch in "run")

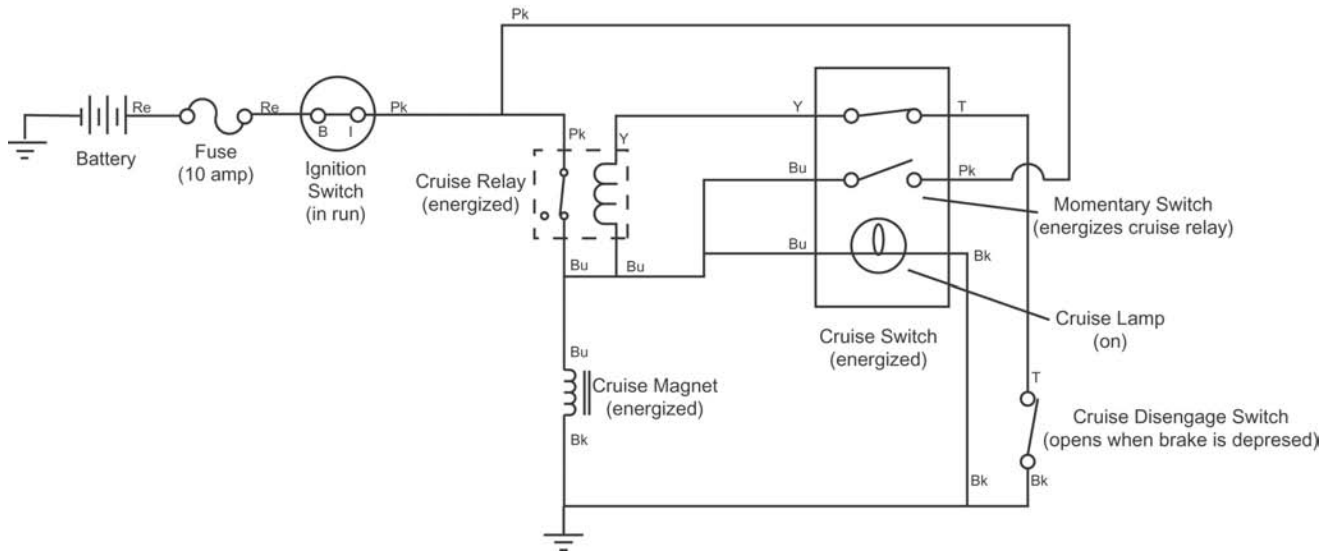

**Charging Circuit**  
(ignition switch in "run")

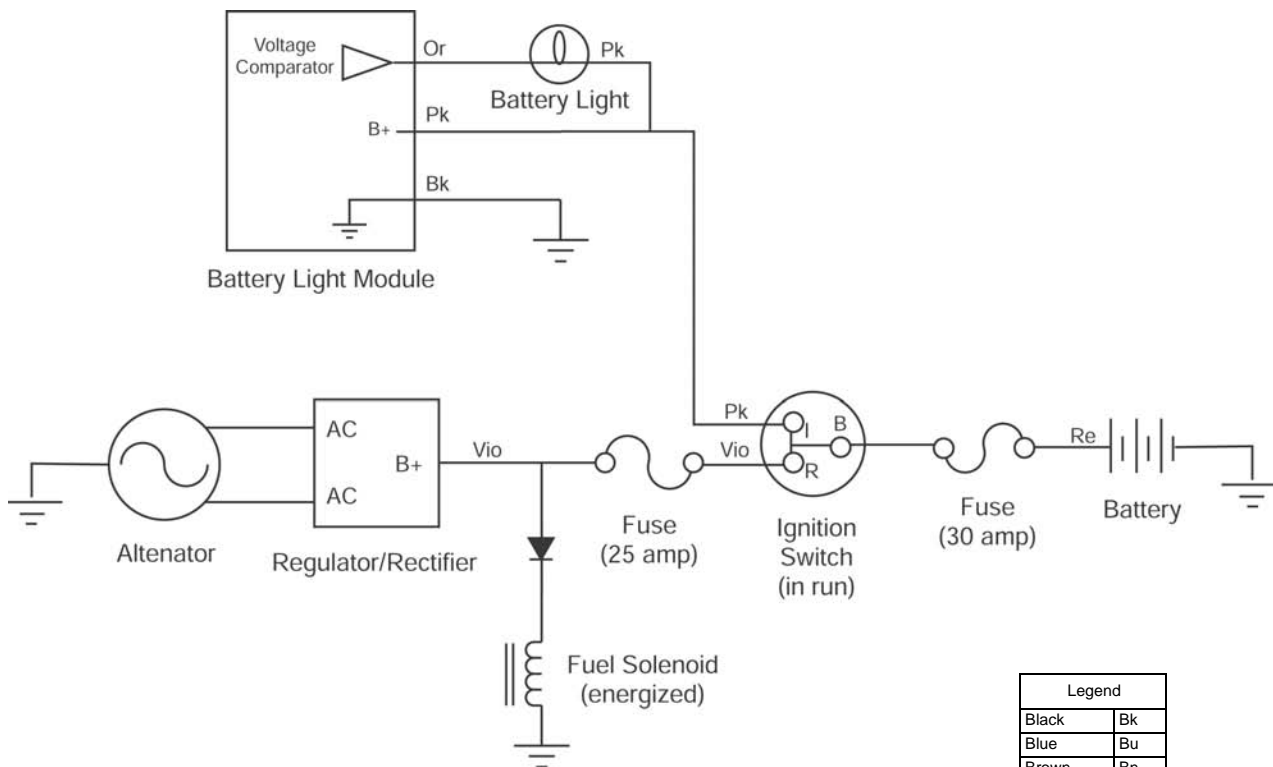

Legend	
Black	Bk
Blue	Bu
Brown	Bn
Green	Gn
Grey	Gy
Orange	Or
Pink	Pk
Red	Re
Tan	T
Violet	Vio
White	W
Yellow	Y

**Circuits**

**Light Circuit**

(ignition switch in "run/lights")

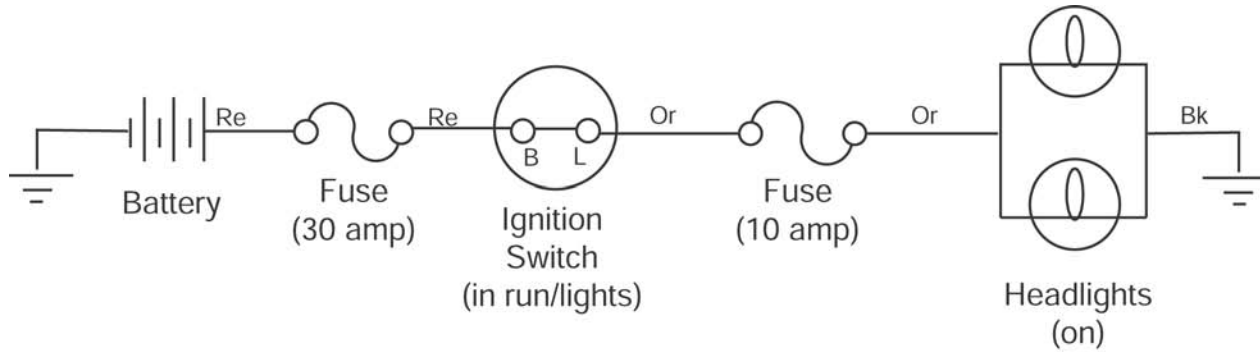

**Hourmeter Circuit**

(ignition switch in "run")

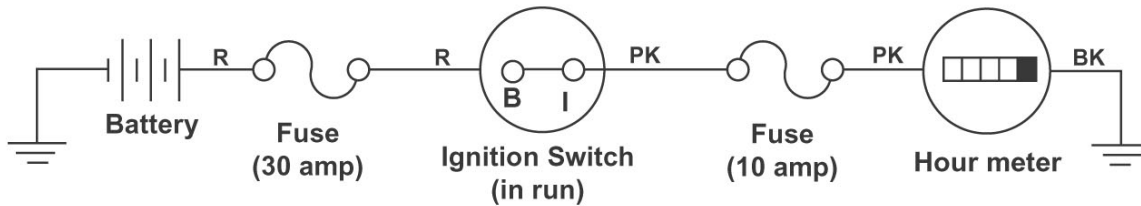

**Oil Pressure Light Circuit**

(ignition switch in "run")

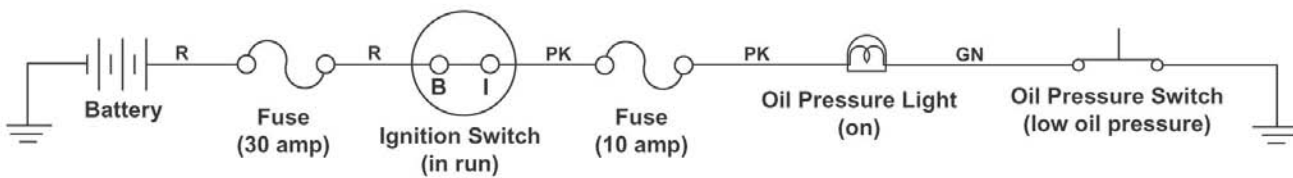

Legend	
Black	Bk
Blue	Bu
Brown	Bn
Green	Gn
Grey	Gy
Orange	Or
Pink	Pk
Red	Re
Tan	T
Violet	Vio
White	W
Yellow	Y

**Lift Pump Circuit**  
(ignition switch in "run")

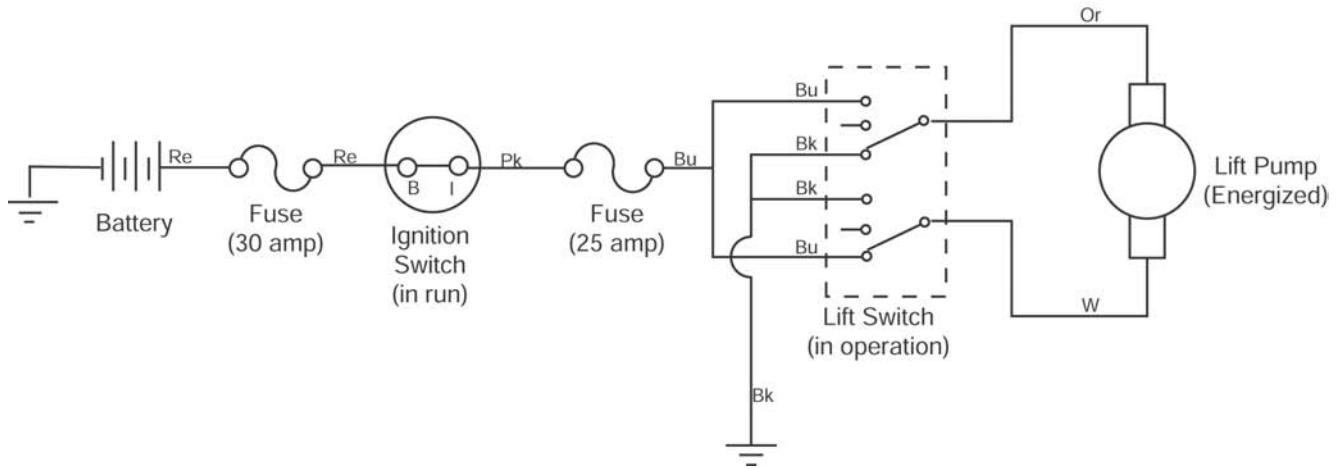

**Engine Temperature Light Circuit**  
(ignition switch in "run")

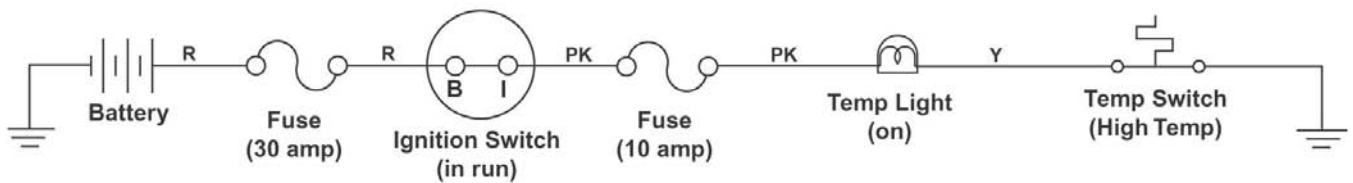

Legend	
Black	Bk
Blue	Bu
Brown	Bn
Green	Gn
Grey	Gy
Orange	Or
Pink	Pk
Red	Re
Tan	T
Violet	Vio
White	W
Yellow	Y

**Circuits**

**This page intentionally left blank**



**315-8 Information List (2002 - 2003)**

Wiring Diagrams . . . . . 10-2 & 10-3  
Circuit Diagrams  
    Starter Motor Circuit . . . . . 10-4  
    Spark Circuits . . . . . 10-4 & 10-5  
    Reverse Operating System Circuits 10-6 - 10-10  
    Battery Charge Circuit . . . . . 10-10  
    Light Circuit . . . . . 10-11  
    Low Oil Pressure Light Circuit . . . . . 10-11  
    Hourmeter . . . . . 10-11

Wiring Diagram

Wiring Diagram

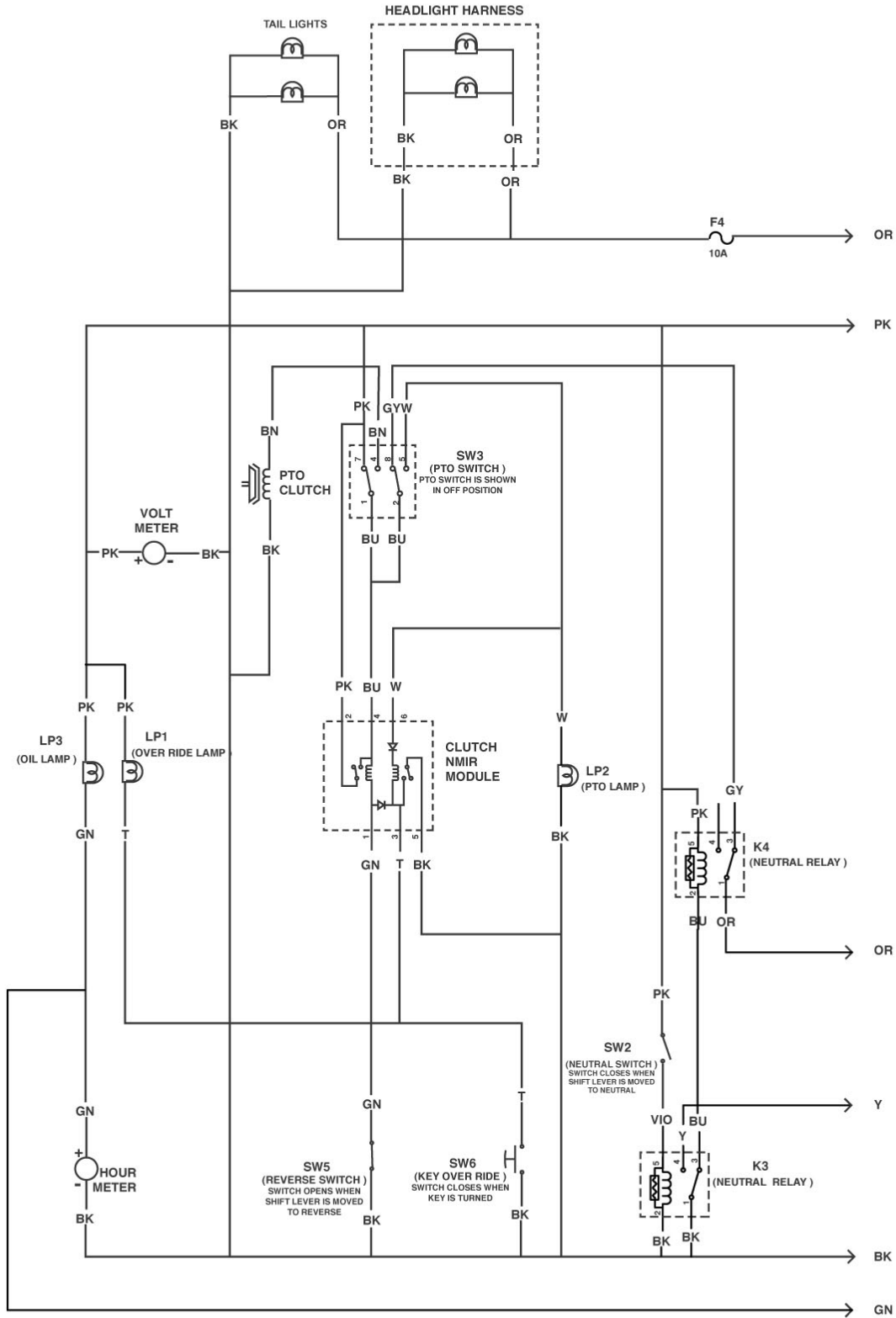



Wiring Diagram

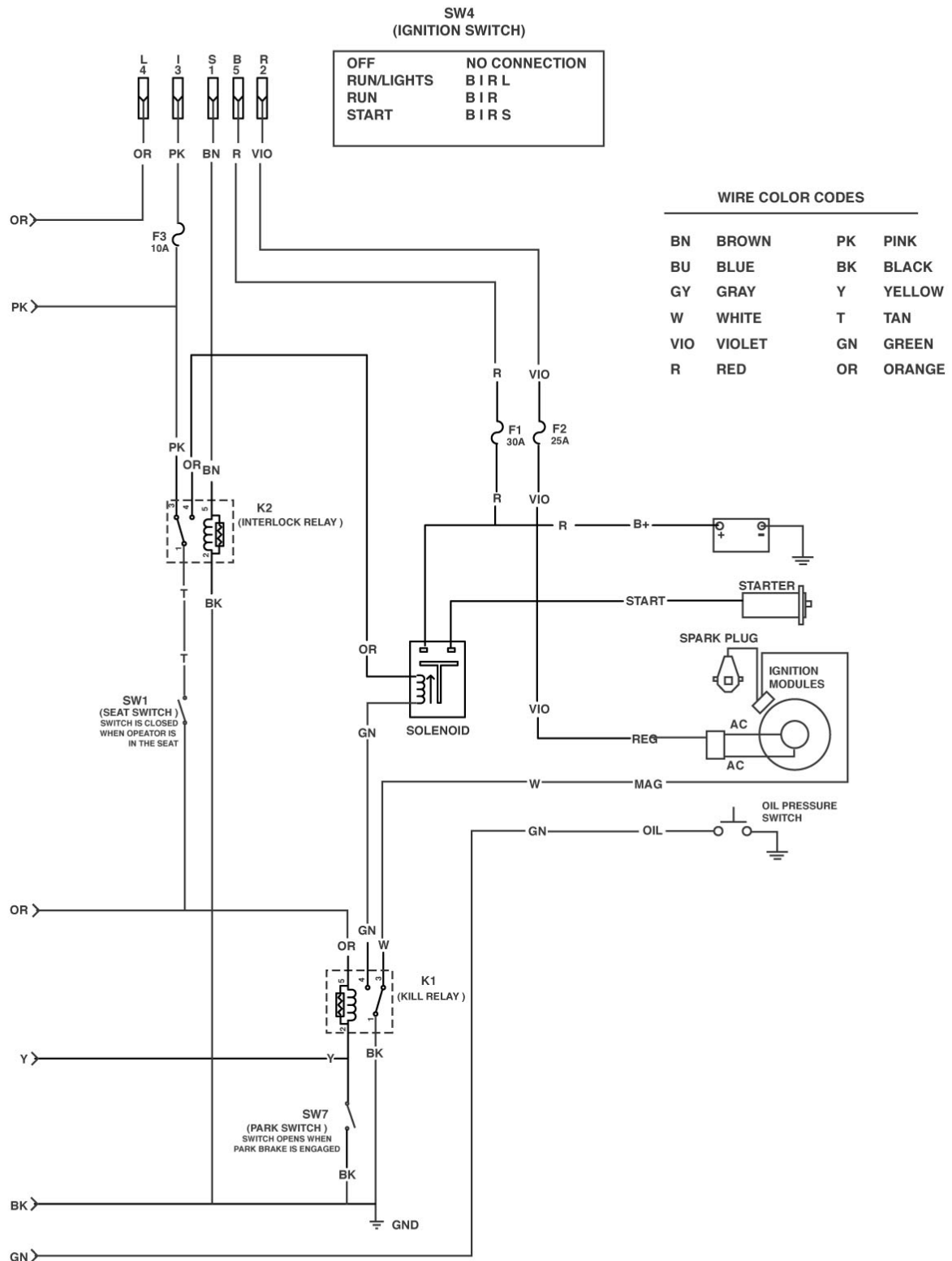

**Wiring Diagram**

**Starter Motor Circuit**  
(ignition switch in "start")

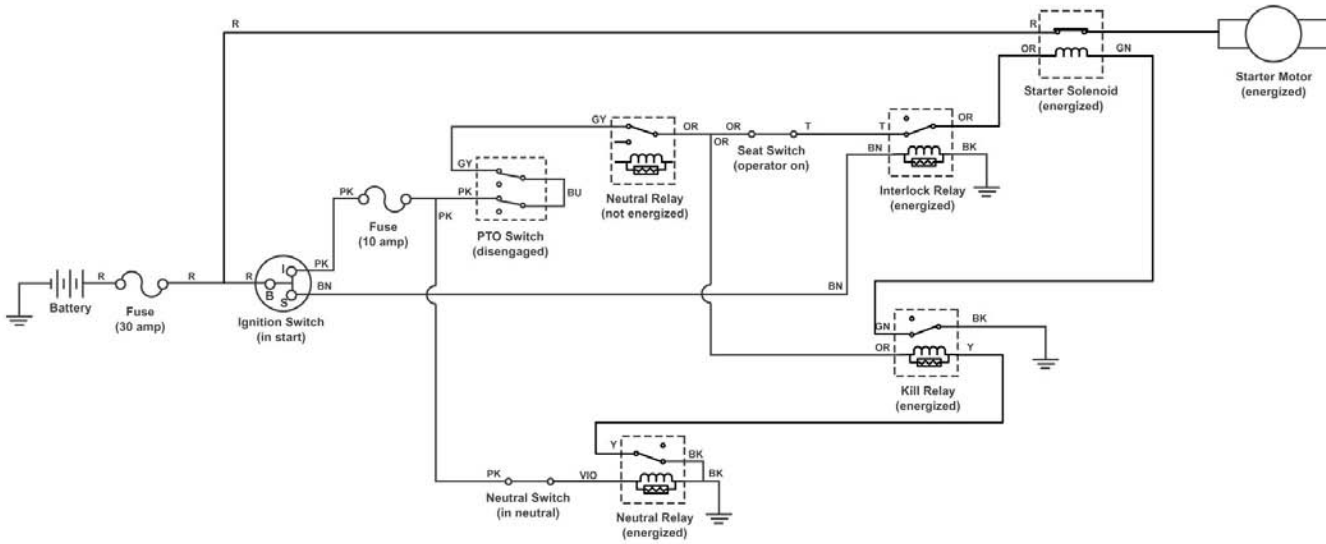

**Spark Circuit**  
(ignition switch in "start" position)

Legend	
Black	Bk
Blue	Bu
Brown	Bn
Green	Gn
Grey	Gy
Orange	Or
Pink	Pk
Red	Re
Tan	T
Violet	Vio
White	W
Yellow	Y

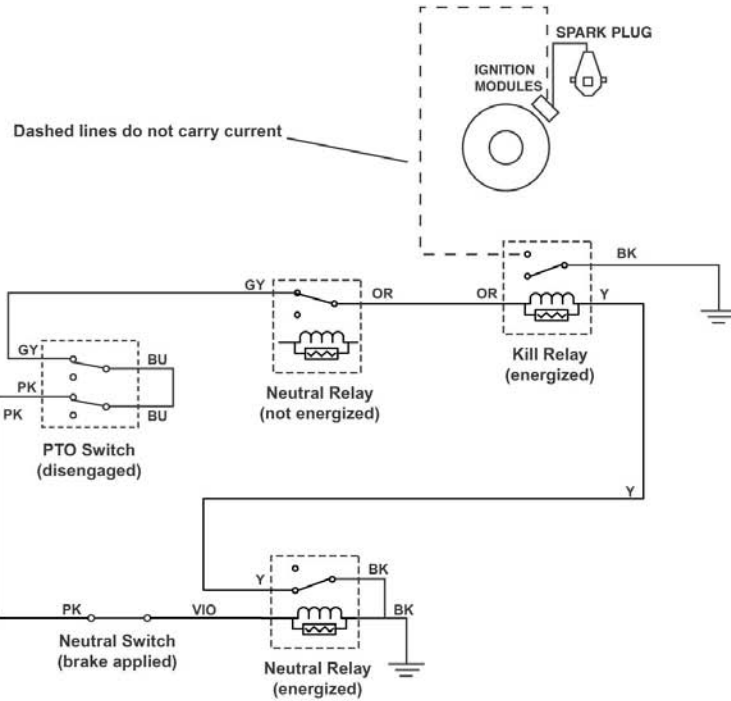

**Circuits**

**Spark Circuit**  
(ignition switch in "run")

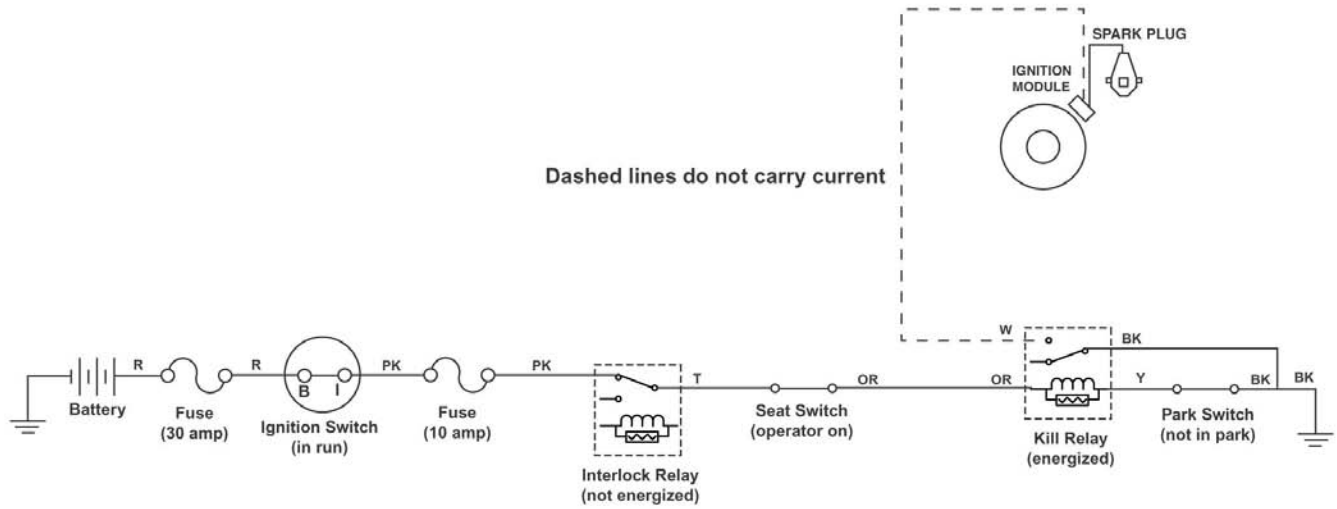

Legend	
Black	Bk
Blue	Bu
Brown	Bn
Green	Gn
Grey	Gy
Orange	Or
Pink	Pk
Red	Re
Tan	T
Violet	Vio
White	W
Yellow	Y

**Reverse Operating System Circuit**

(PTO "off", in forward)

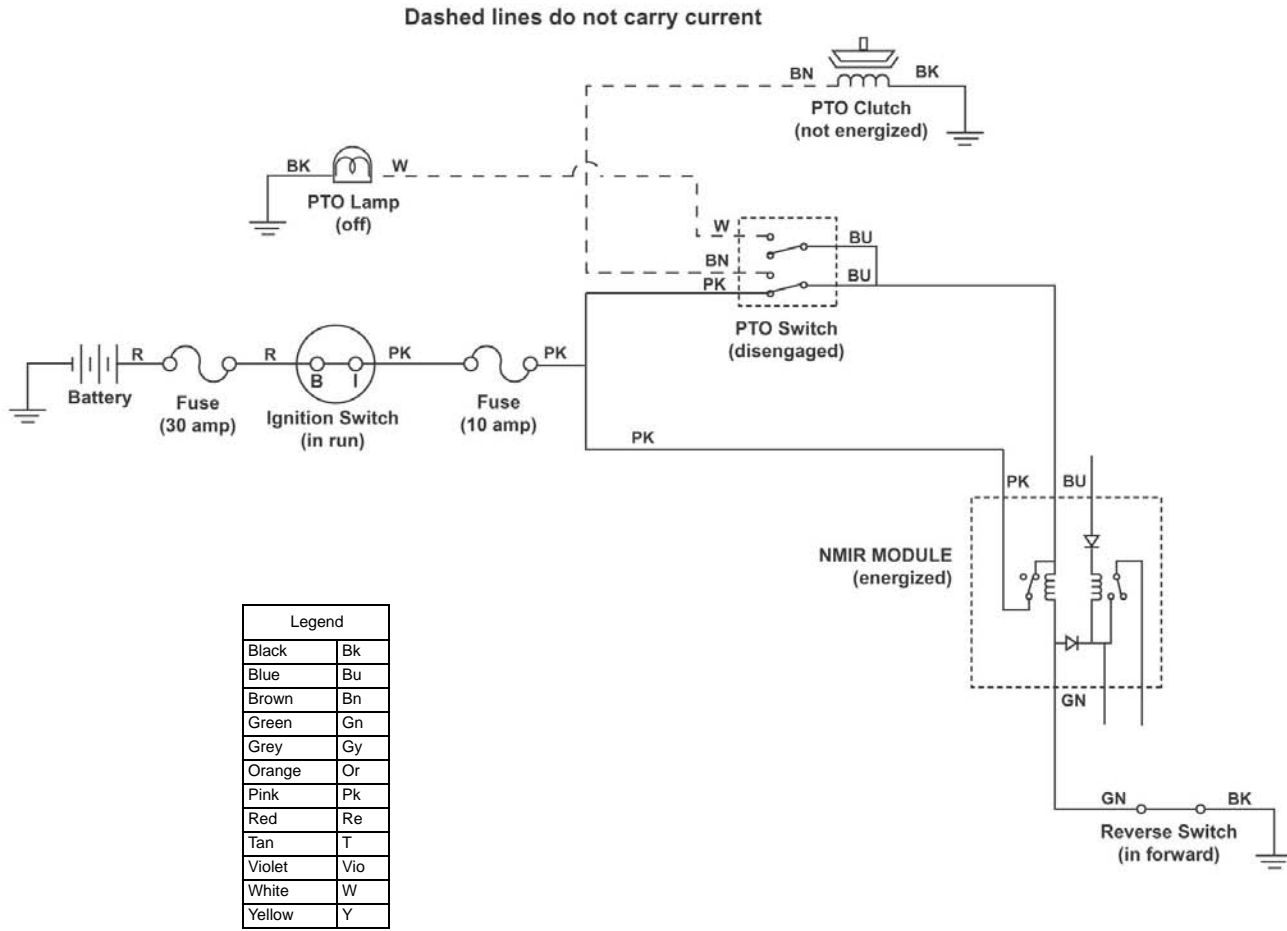

**Reverse Operating System Circuit**  
(PTO "on", in forward)

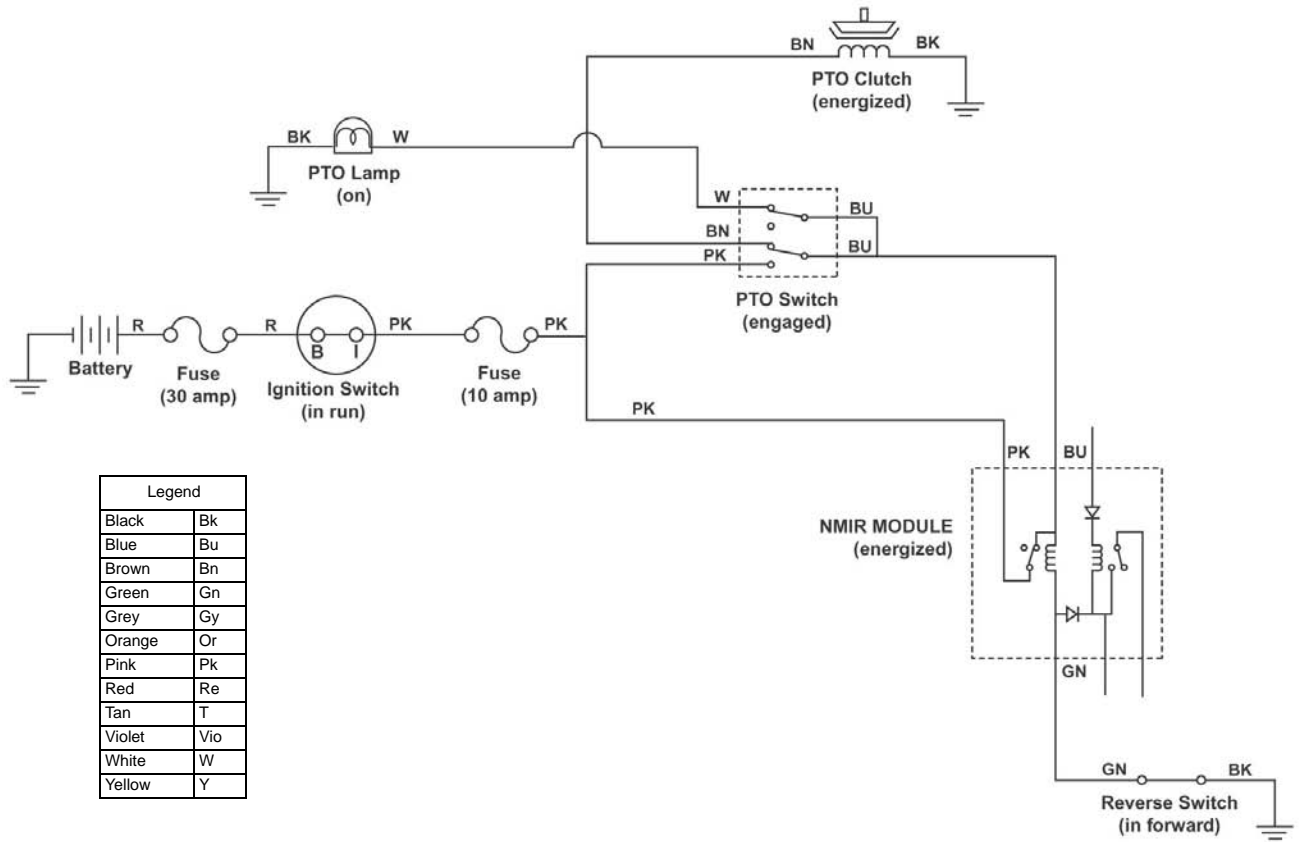

Legend	
Black	Bk
Blue	Bu
Brown	Bn
Green	Gn
Grey	Gy
Orange	Or
Pink	Pk
Red	Re
Tan	T
Violet	Vio
White	W
Yellow	Y

**Circuits**

**Reverse Operating System Circuit**  
 (PTO "on", in reverse)

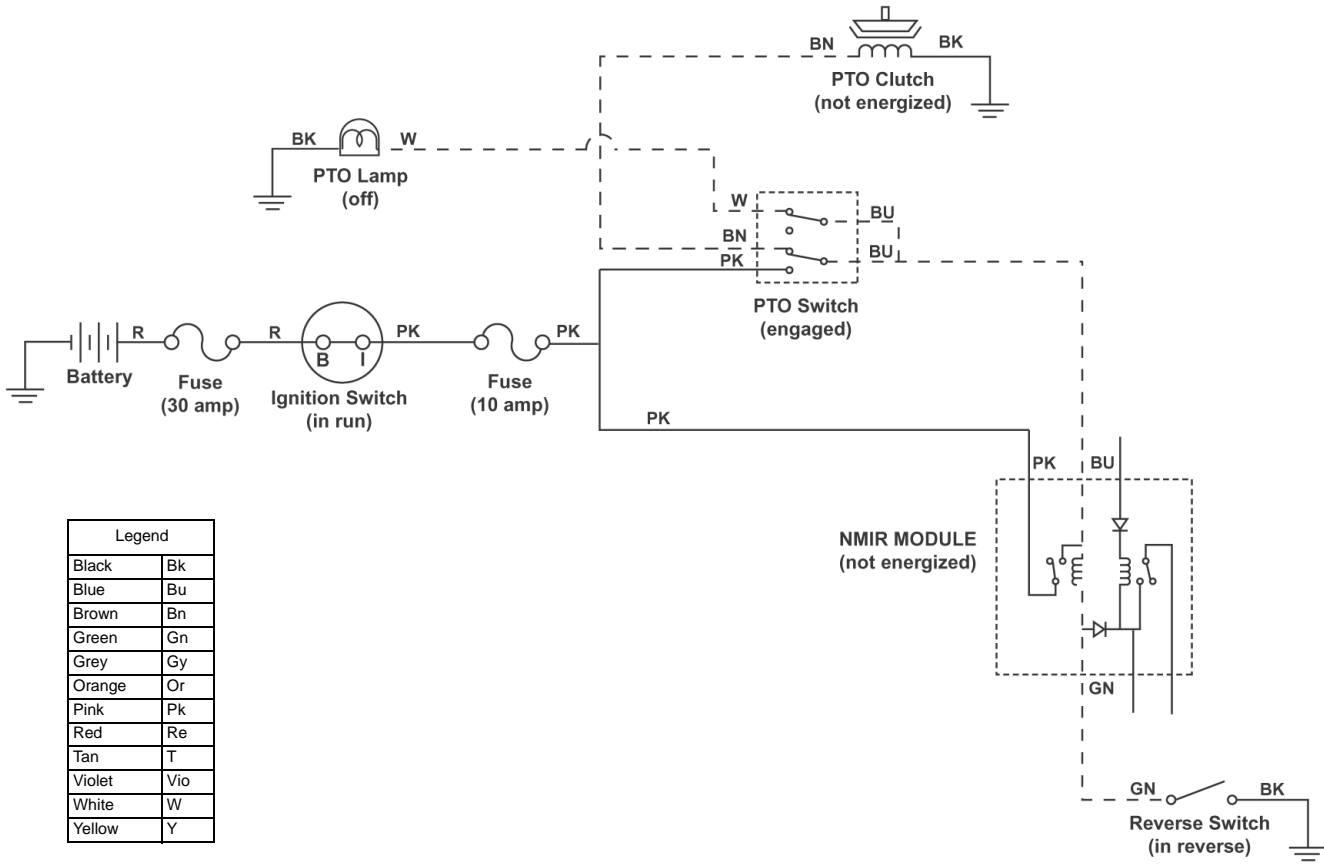

Legend	
Black	Bk
Blue	Bu
Brown	Bn
Green	Gn
Grey	Gy
Orange	Or
Pink	Pk
Red	Re
Tan	T
Violet	Vio
White	W
Yellow	Y

**Reverse Operating System Circuit**  
*(Override key switch "activated")*

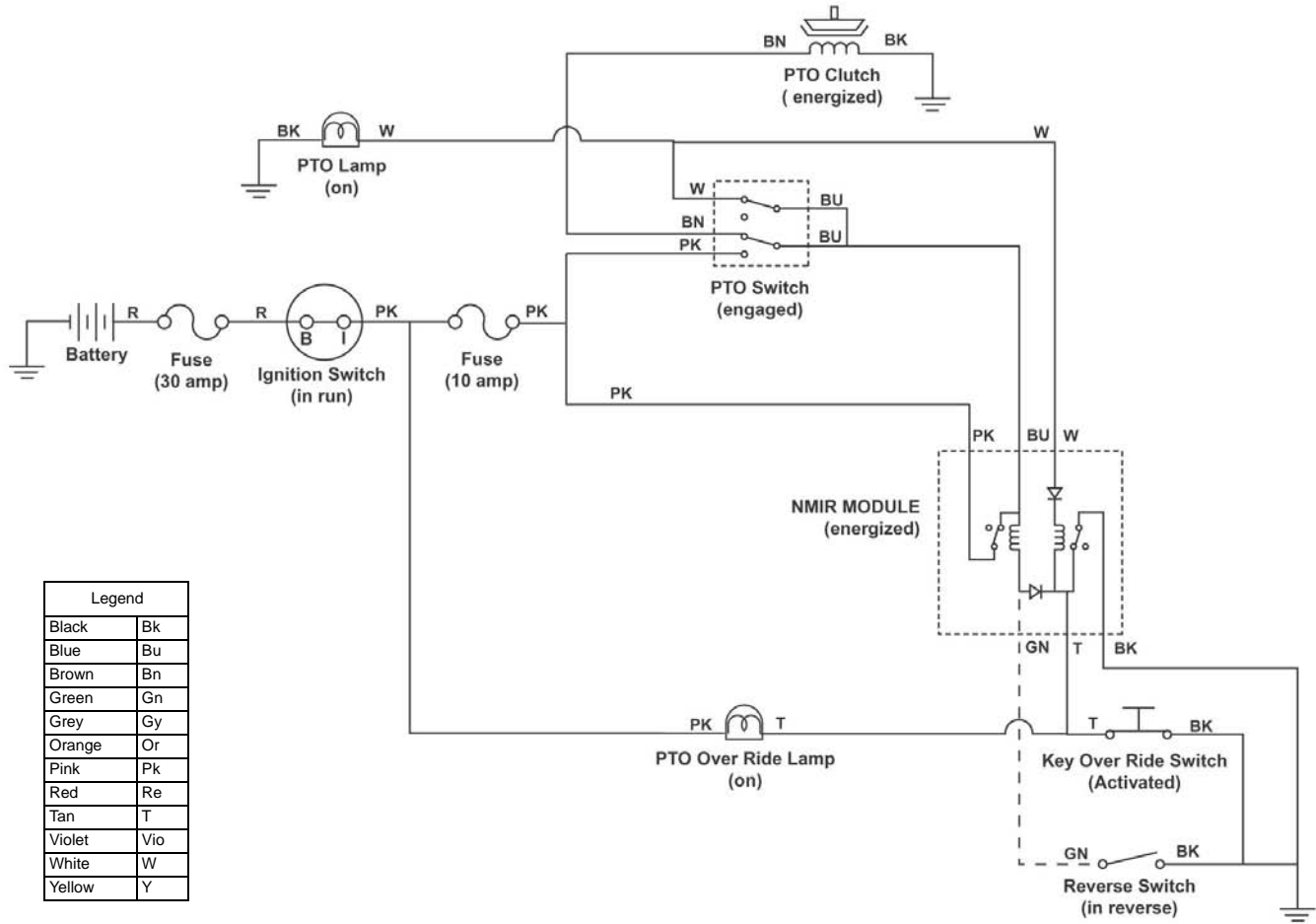

**Circuits**

**Reverse Operating System Circuit**

*(PTO "on", in reverse, override mode)*

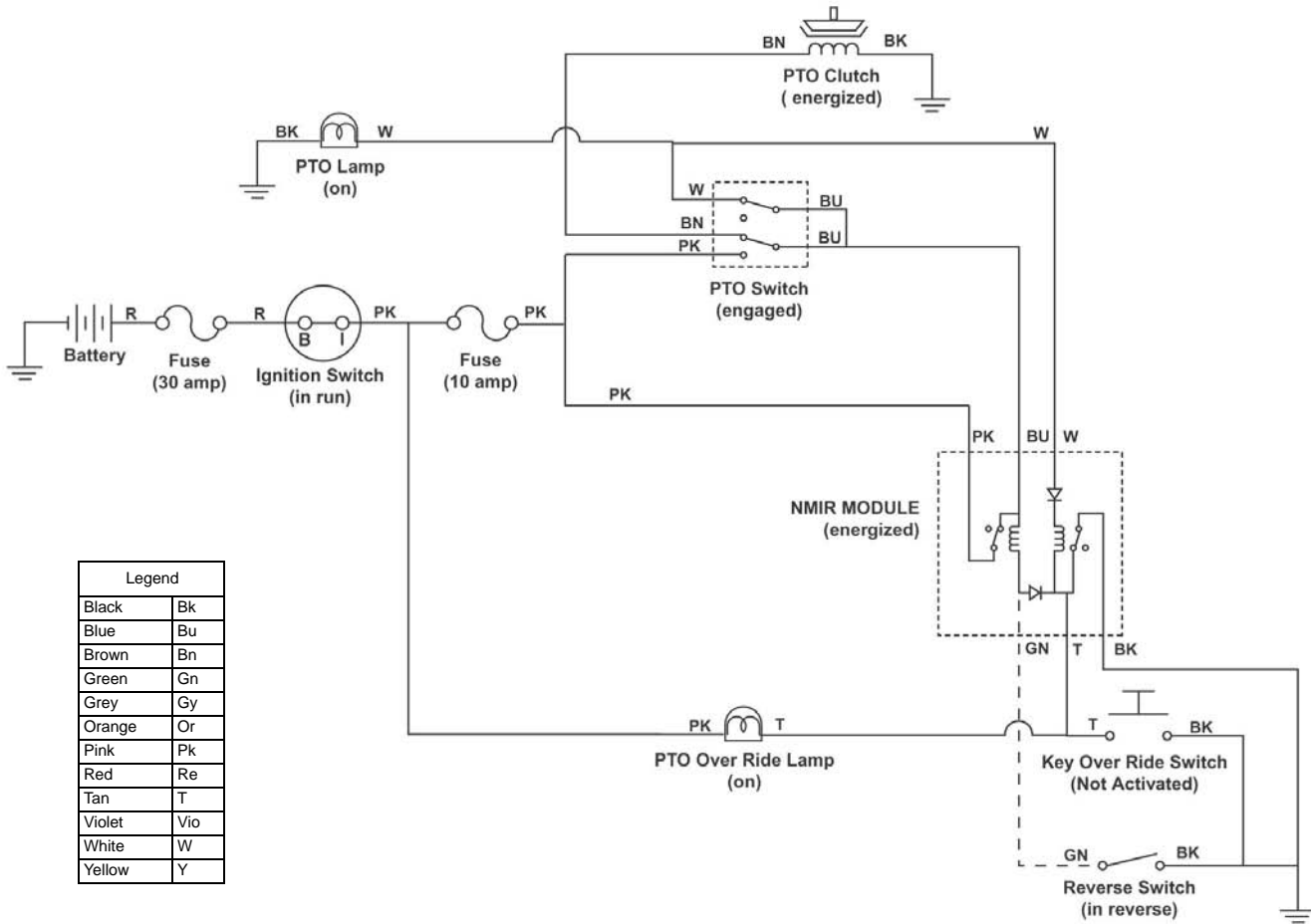

**Battery Charge Circuit**

*(ignition switch in "run")*

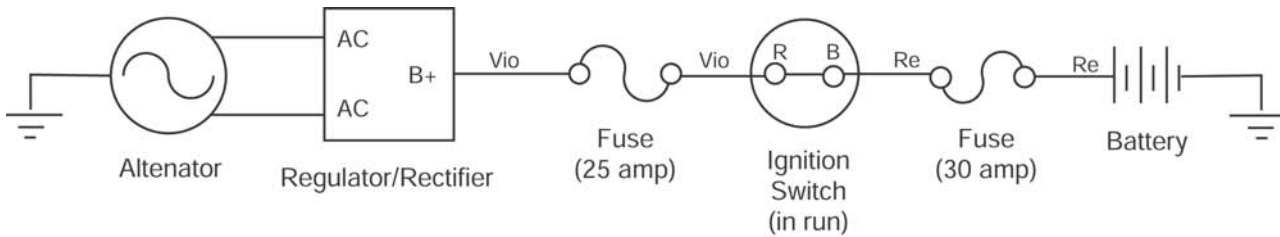

Circuits



**Light Circuit**

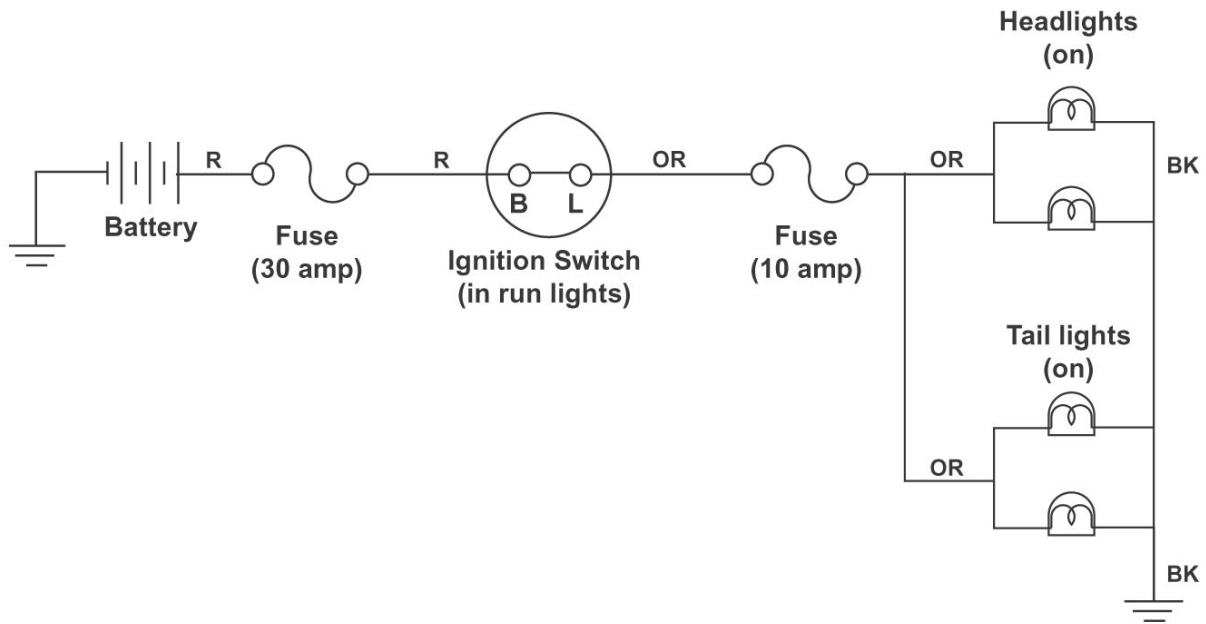

**Low Oil Pressure Light Circuit  
(ignition switch in "run")**

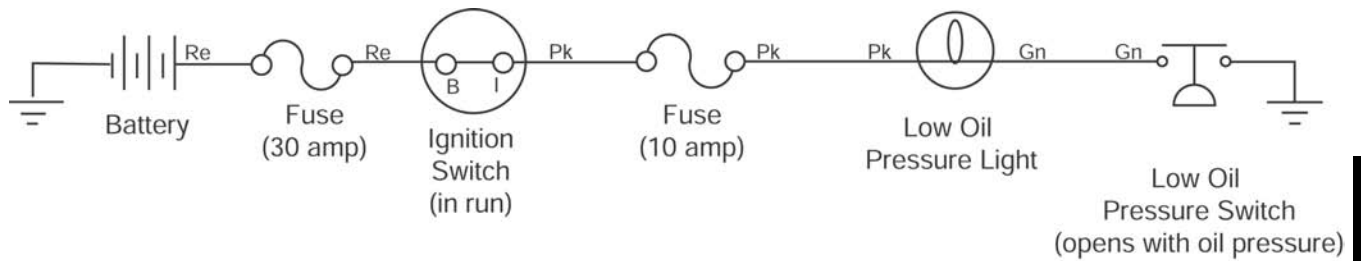

**Hourmeter  
(ignition switch in "run")**

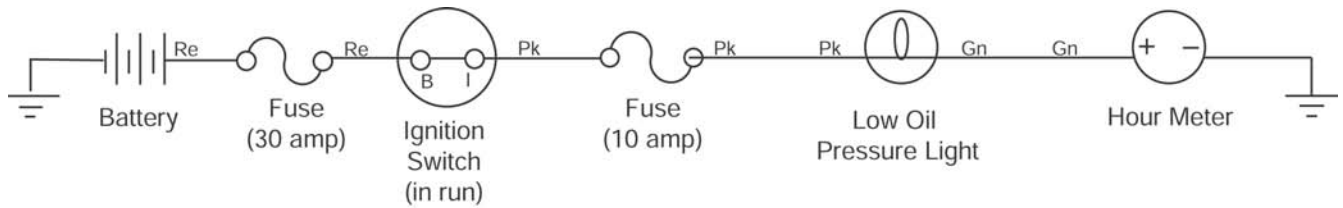

Legend	
Black	Bk
Blue	Bu
Brown	Bn
Green	Gn
Grey	Gy
Orange	Or
Pink	Pk
Red	Re
Tan	T
Violet	Vio
White	W
Yellow	Y

**Circuits**

**This page intentionally left blank**



**416XT Information List (2003)**

Wiring Diagrams . . . . . 11-2 & 11-3  
Circuit Diagrams  
    Starter Motor Circuit . . . . . 11-4  
    Spark Circuits . . . . . 11-5 & 11-6  
    Reverse Operating System Circuits 11-7 - 11-11  
    Light Circuit . . . . . 11-11  
    Battery Charge Circuit . . . . . 11-12  
    Hourmeter . . . . . 11-12

Wiring Diagram

Wiring Diagram

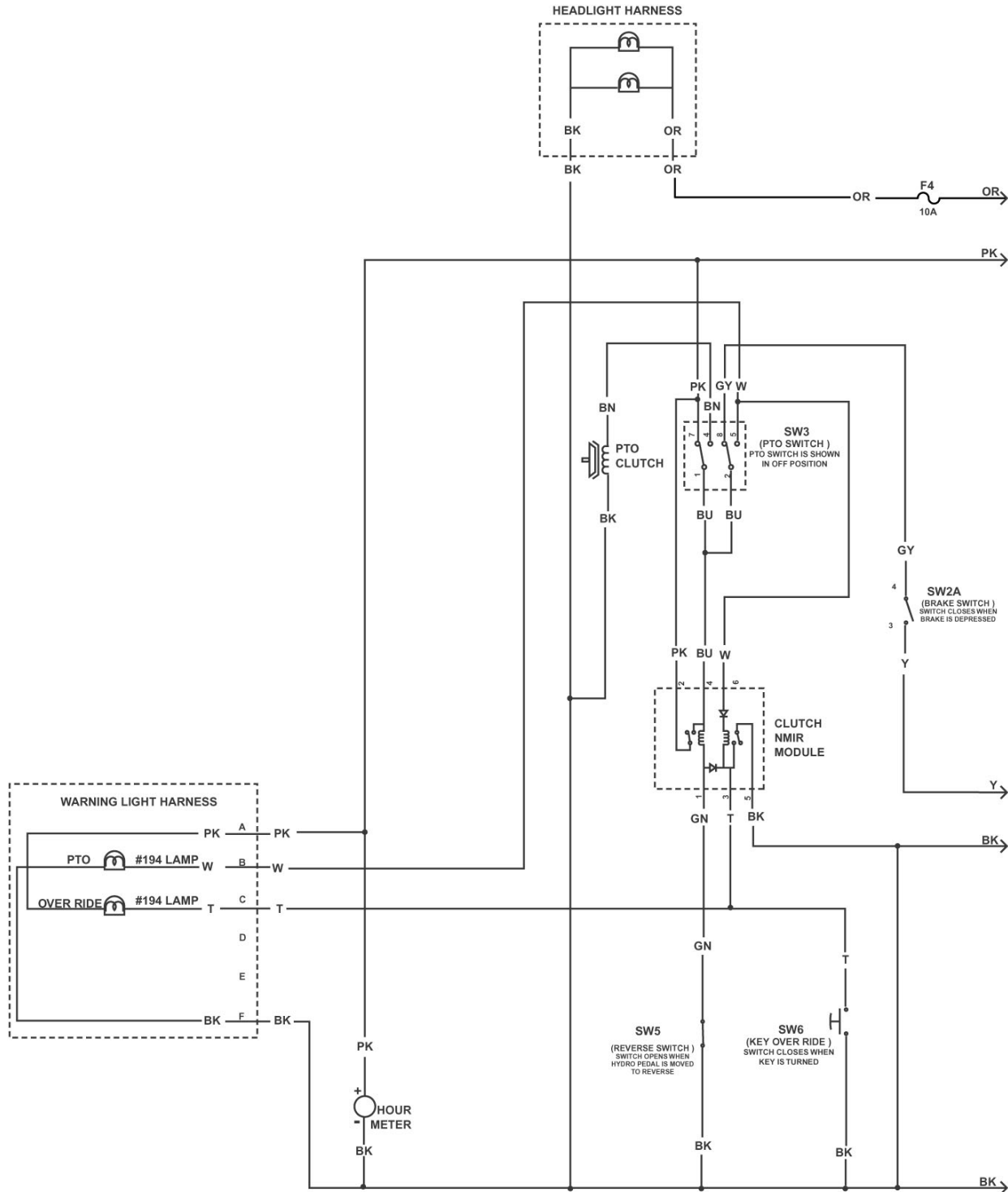

Wiring Diagram

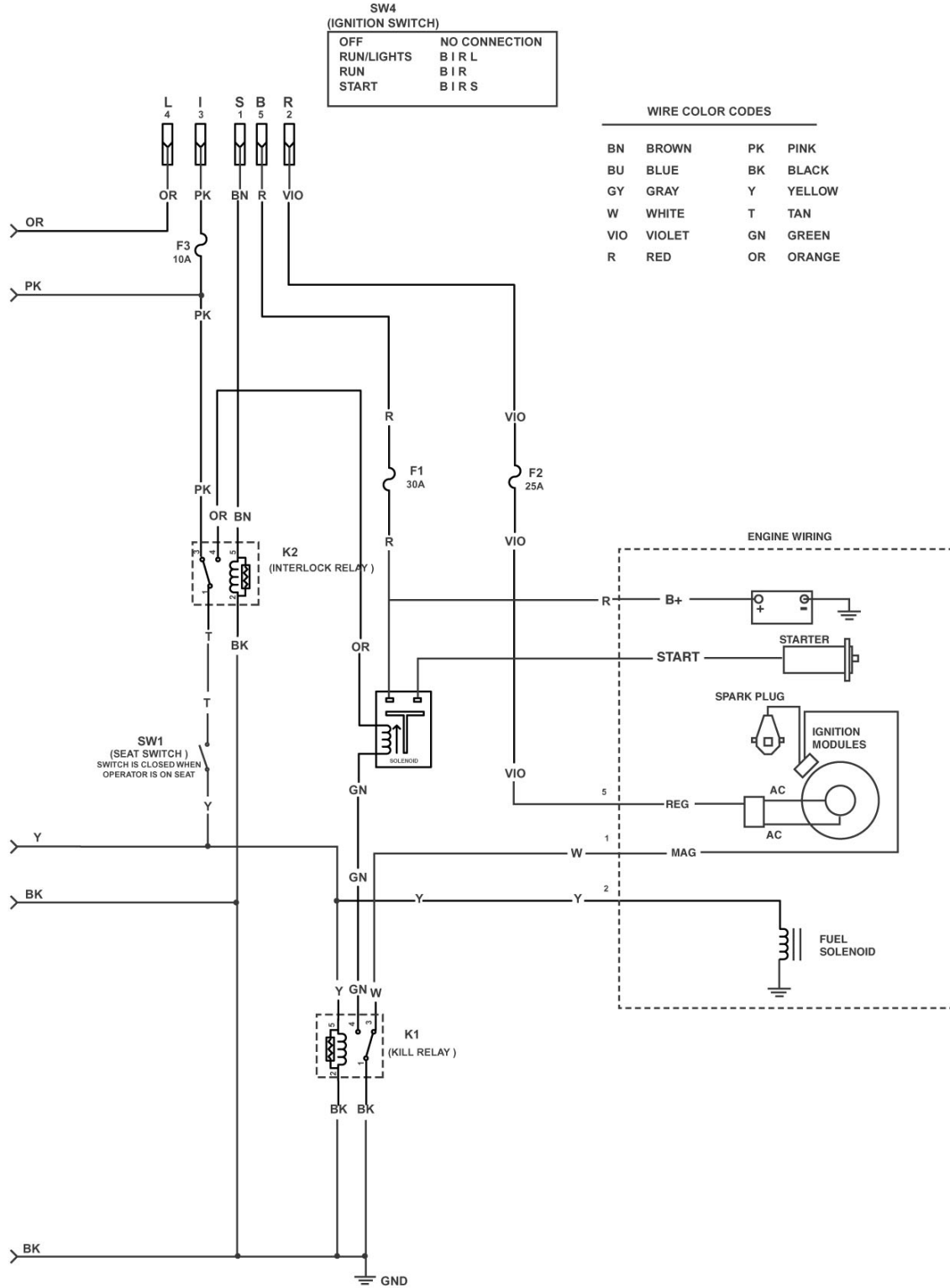

Wiring Diagram

**Starter Motor Circuit**  
(ignition switch in "start")

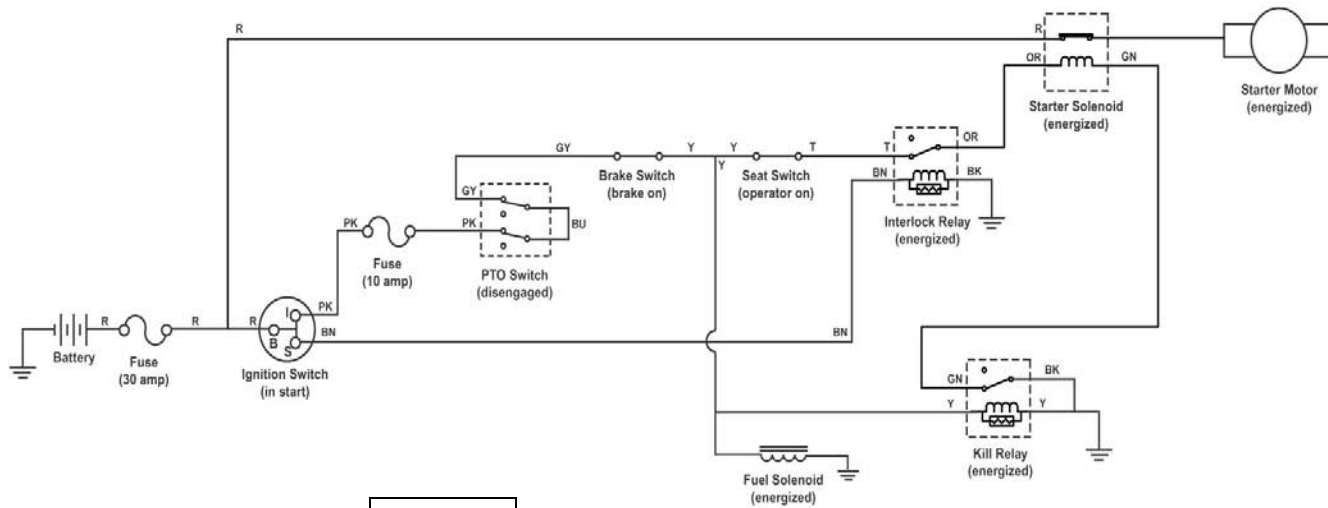

Legend	
Black	Bk
Blue	Bu
Brown	Bn
Green	Gn
Grey	Gy
Orange	Or
Pink	Pk
Red	Re
Tan	T
Violet	Vio
White	W
Yellow	Y

**Spark Circuit**  
(ignition switch in "start" position)

Legend	
Black	Bk
Blue	Bu
Brown	Bn
Green	Gn
Grey	Gy
Orange	Or
Pink	Pk
Red	Re
Tan	T
Violet	Vio
White	W
Yellow	Y

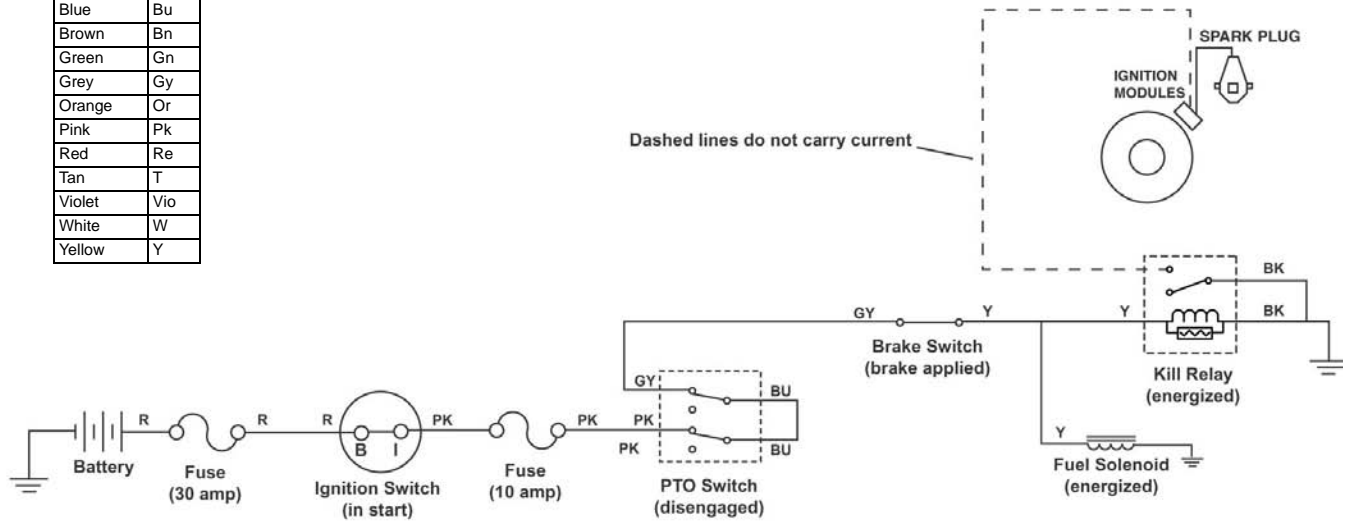

**Spark Circuit**  
(ignition switch in "run")

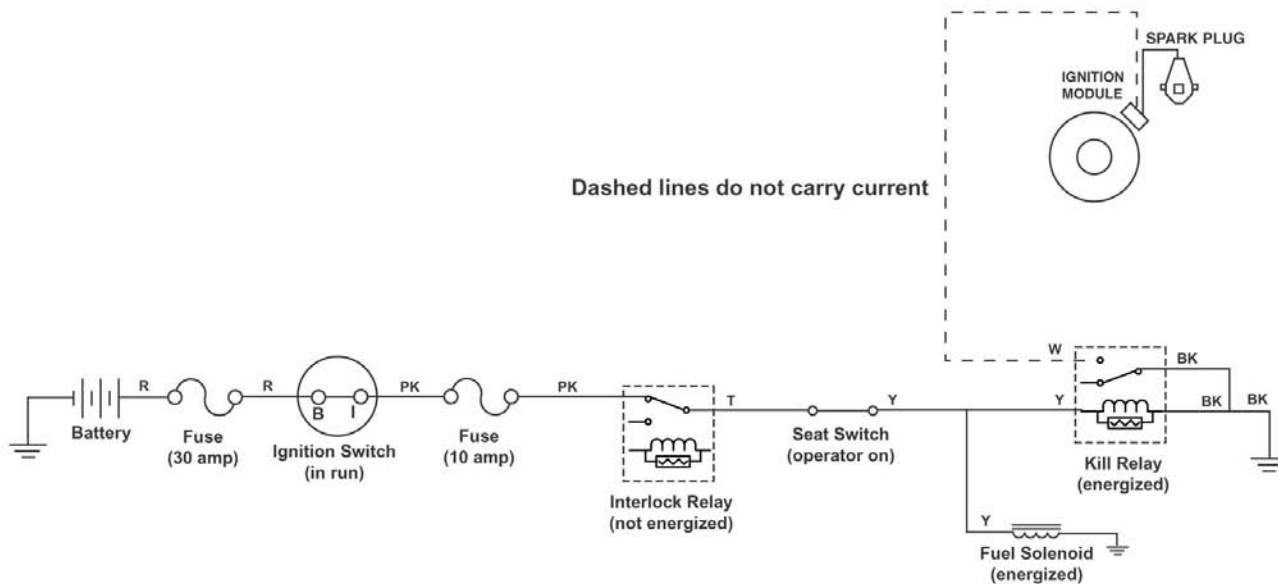

Legend	
Black	Bk
Blue	Bu
Brown	Bn
Green	Gn
Grey	Gy
Orange	Or
Pink	Pk
Red	Re
Tan	T
Violet	Vio
White	W
Yellow	Y



**Reverse Operating System Circuit**  
*(PTO "off", in forward)*

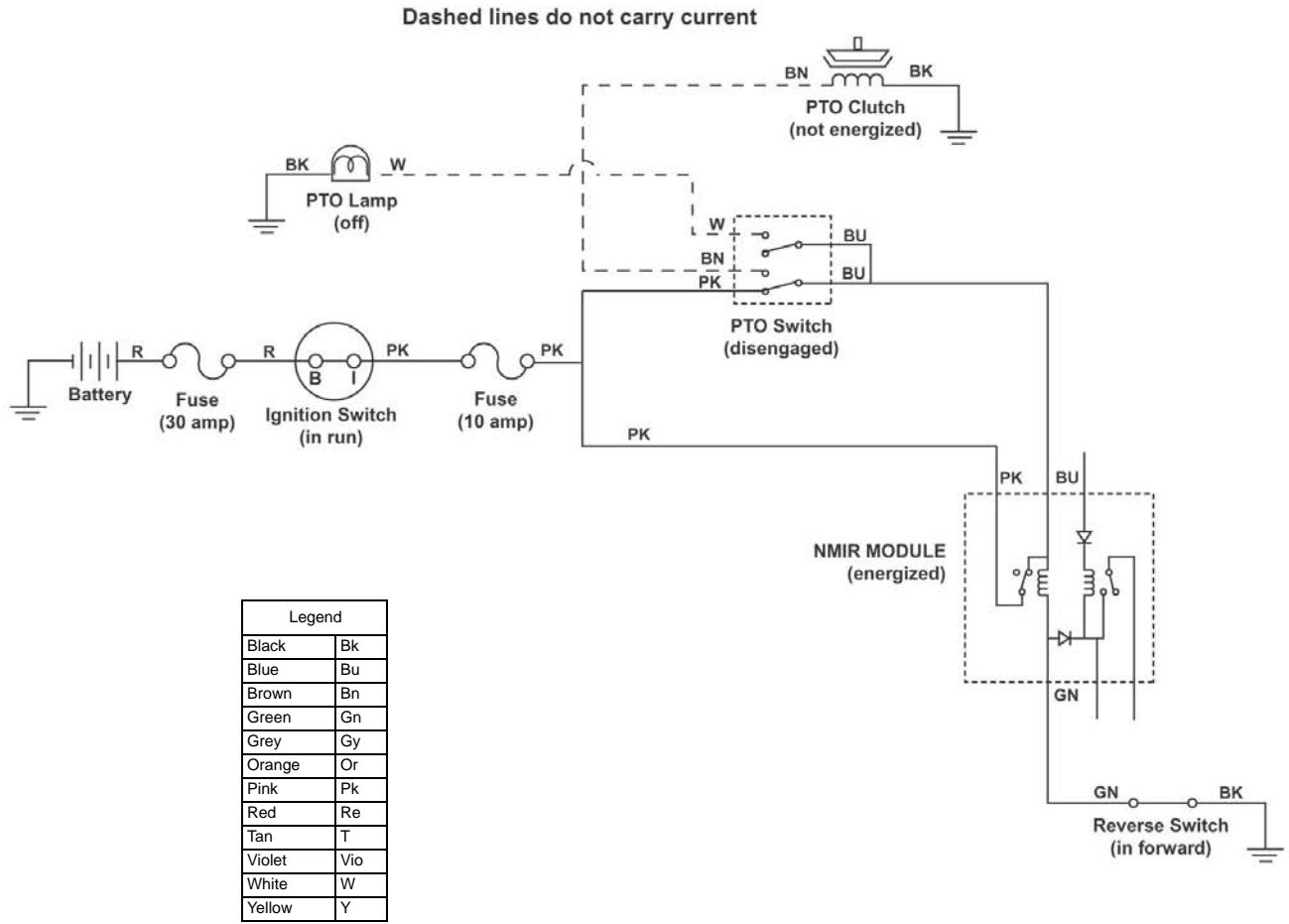

**Reverse Operating System Circuit**  
*(PTO "on", in forward)*

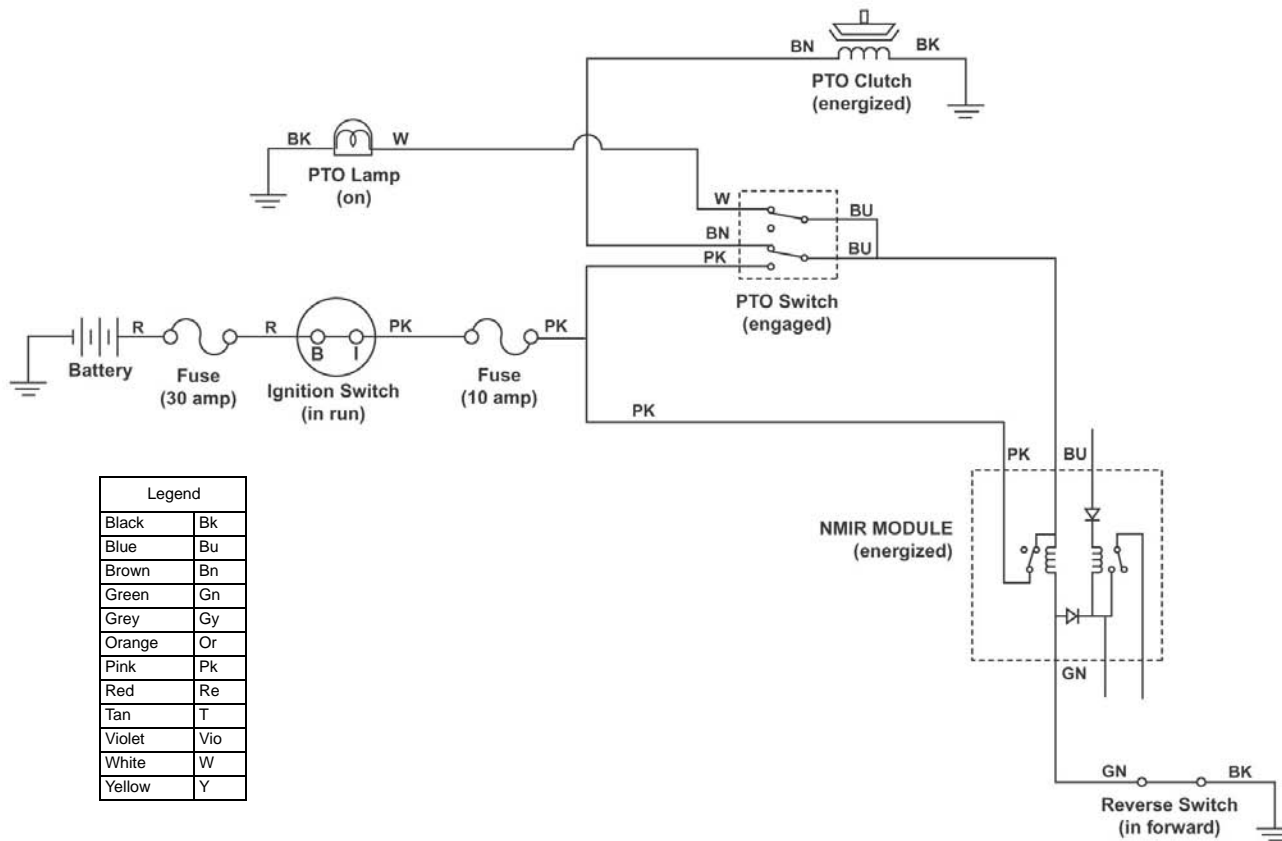

**Reverse Operating System Circuit**  
(PTO "on", in reverse)

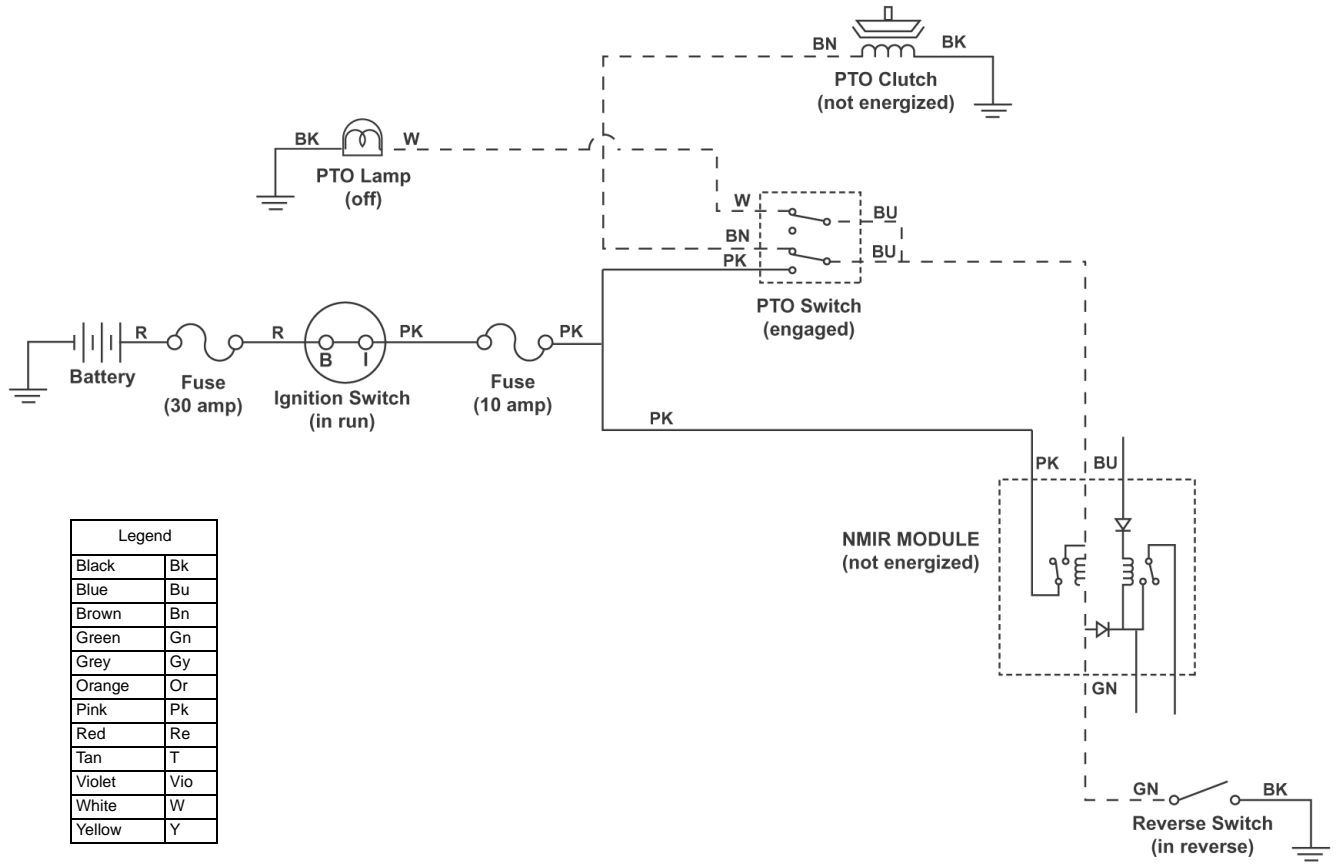

Legend	
Black	Bk
Blue	Bu
Brown	Bn
Green	Gn
Grey	Gy
Orange	Or
Pink	Pk
Red	Re
Tan	T
Violet	Vio
White	W
Yellow	Y

**Reverse Operating System Circuit**  
(Override key switch "activated")

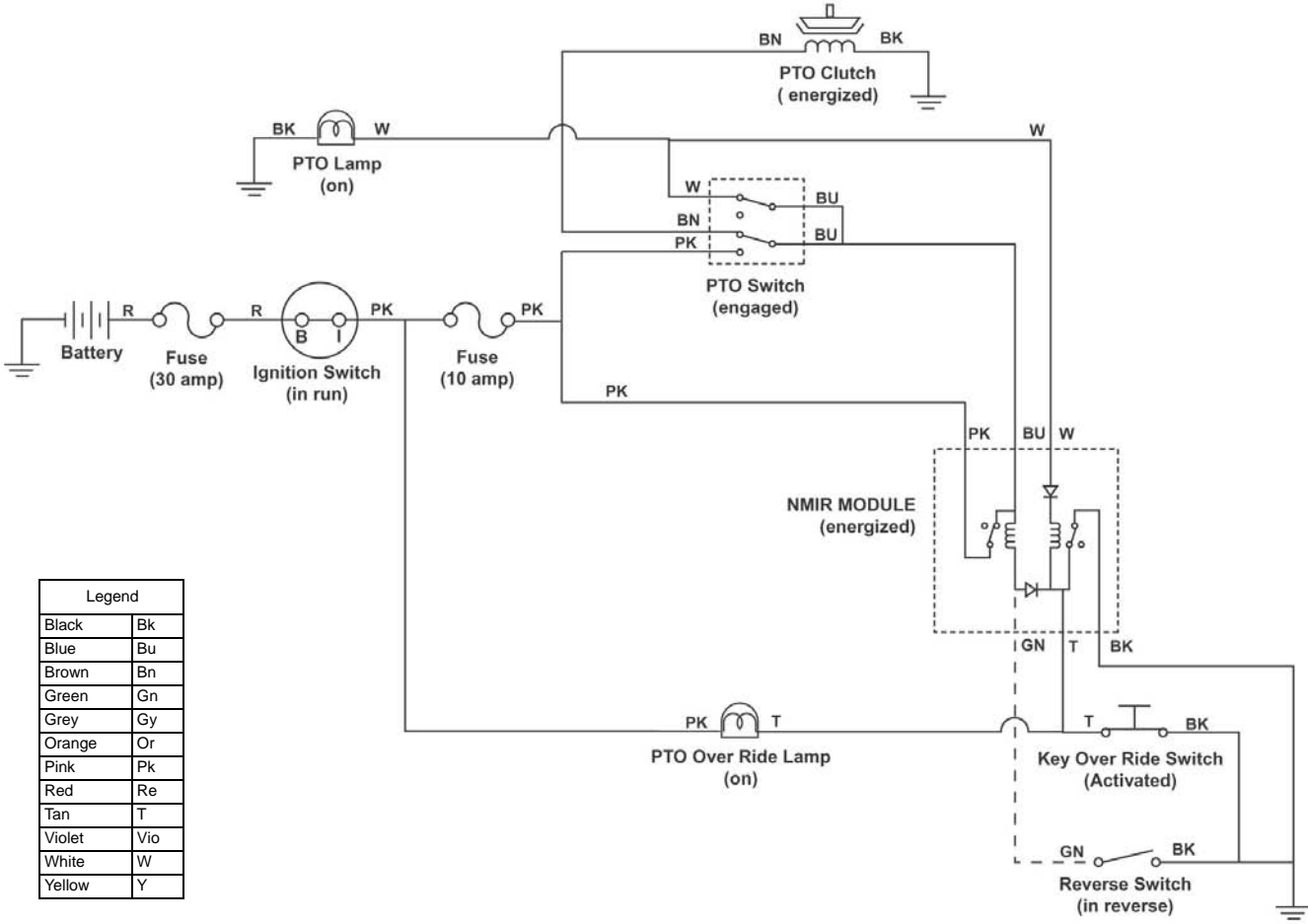

Legend	
Black	Bk
Blue	Bu
Brown	Bn
Green	Gn
Grey	Gy
Orange	Or
Pink	Pk
Red	Re
Tan	T
Violet	Vio
White	W
Yellow	Y

**Reverse Operating System Circuit**  
(PTO "on", in reverse, override mode)

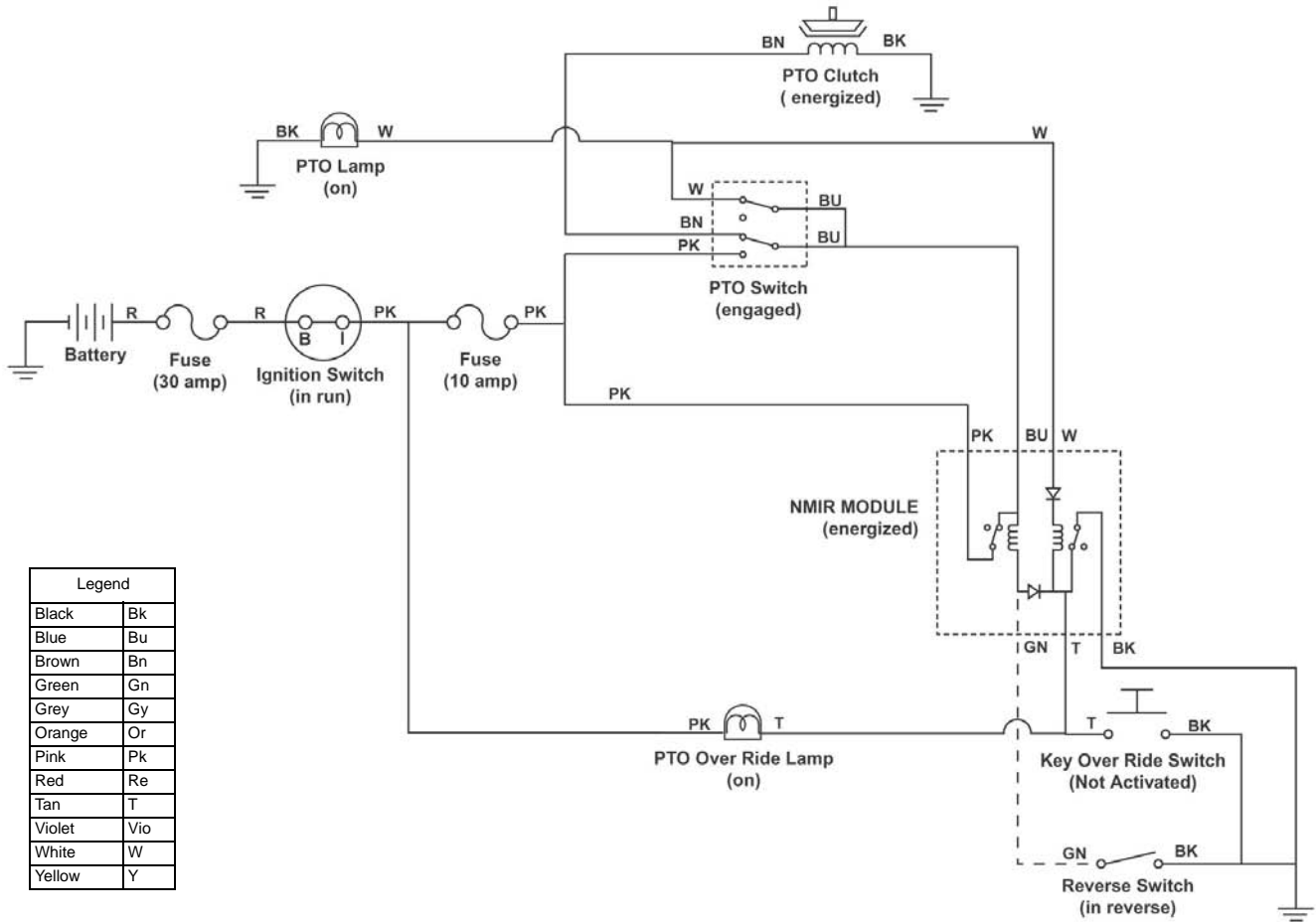

**Light Circuit**  
(ignition switch in "run/lights")

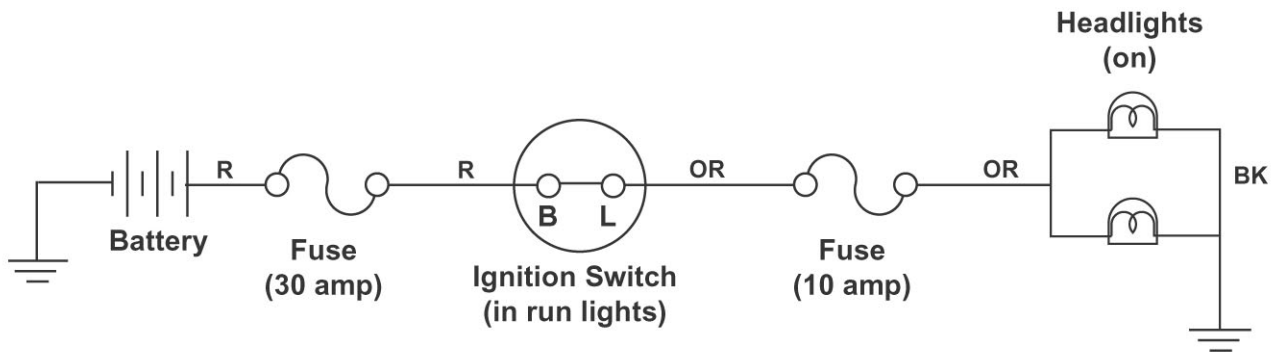

**Circuits**

**Battery Charge Circuit**

(ignition switch in "run")

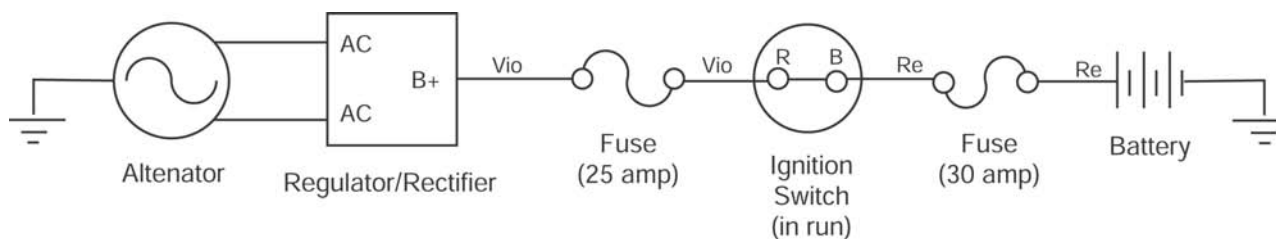

**Hourmeter**

(ignition switch in "run")

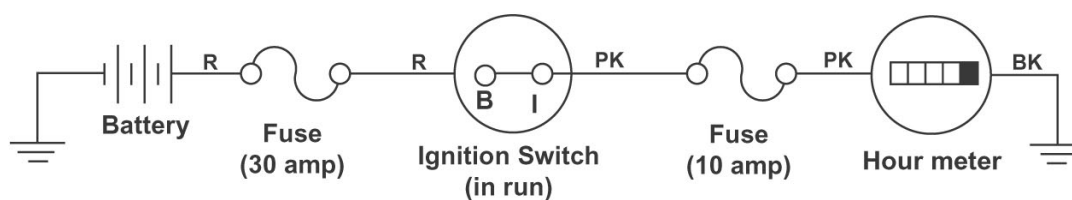

Legend	
Black	Bk
Blue	Bu
Brown	Bn
Green	Gn
Grey	Gy
Orange	Or
Pink	Pk
Red	Re
Tan	T
Violet	Vio
White	W
Yellow	Y



**417XT Information List (2003)**

Wiring Diagrams. . . . . 12-2 & 12-3

Circuit Diagrams

- Starter Motor Circuit. . . . . 12-4
- Spark Circuits . . . . . 12-4 & 12-5
- Reverse Operating System Circuits 12-6 - 12-10
- Light Circuit . . . . . 12-10
- Battery Charge Circuit . . . . . 12-11
- Hourmeter Circuit . . . . . 12-11
- Oil Pressure Light Circuit . . . . . 12-11
- Cruise Control Circuit . . . . . 12-12

Wiring Diagram

Wiring Diagram

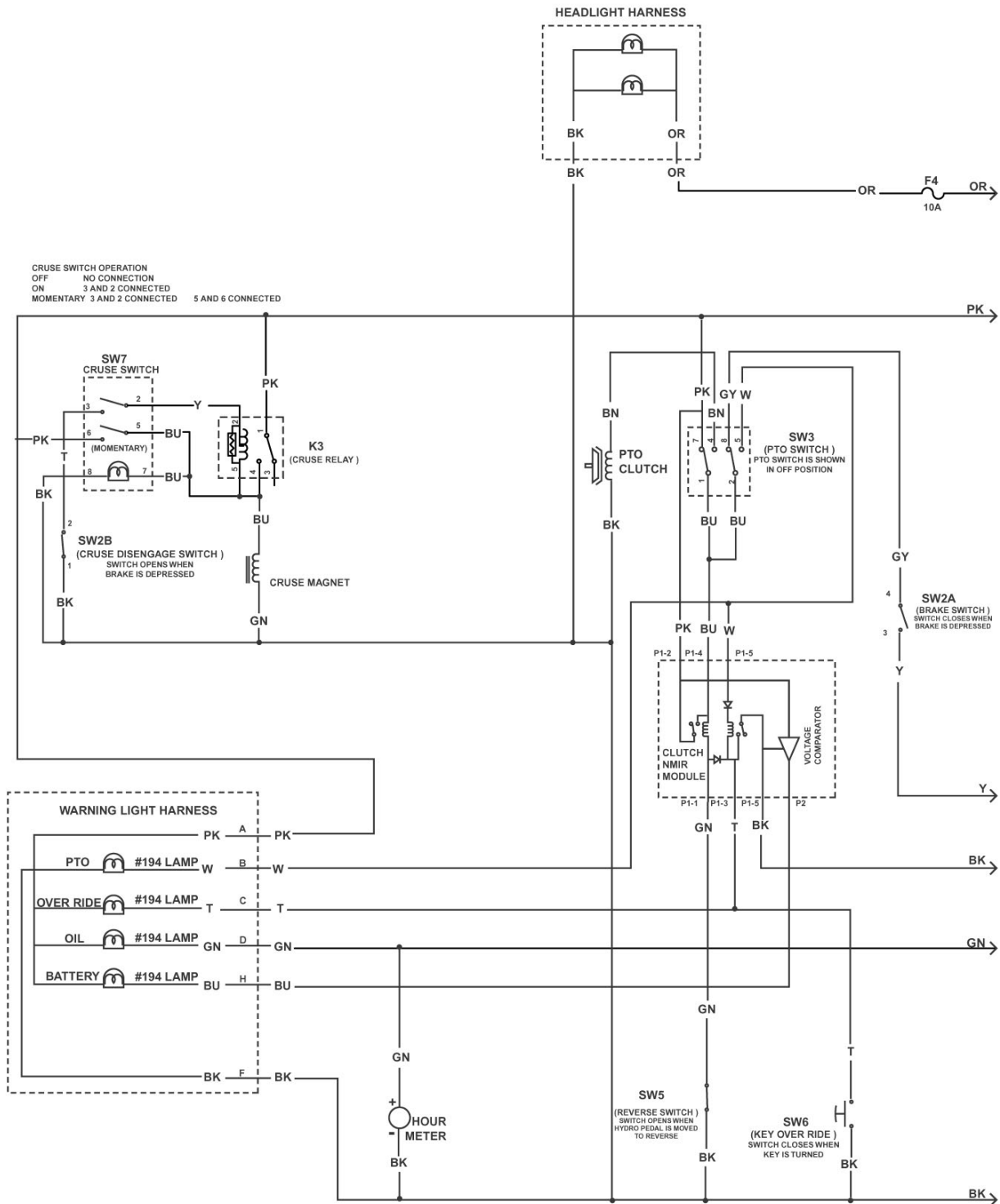



Wiring Diagram

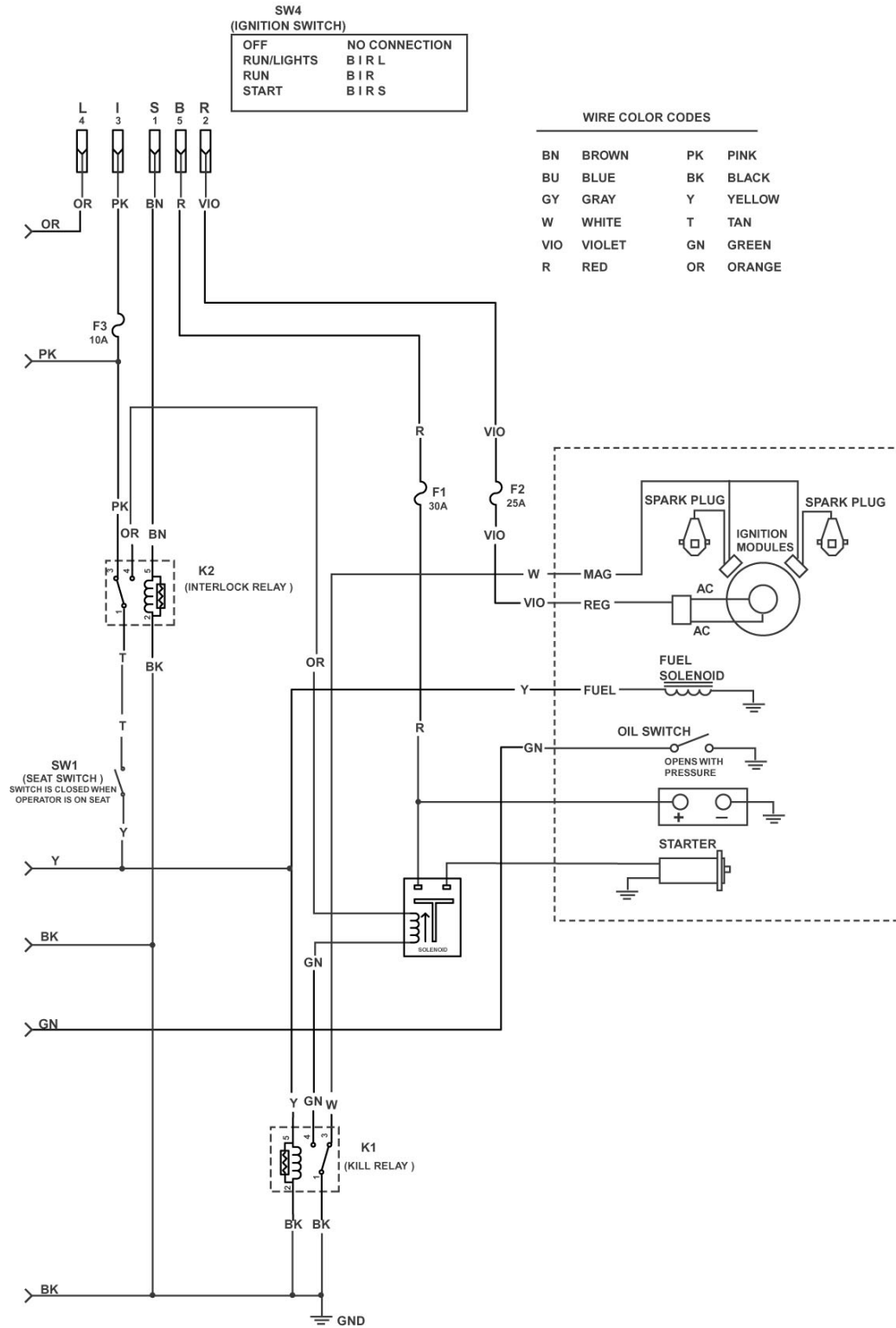

Wiring Diagram

**Starter Motor Circuit**  
(ignition switch in "start")

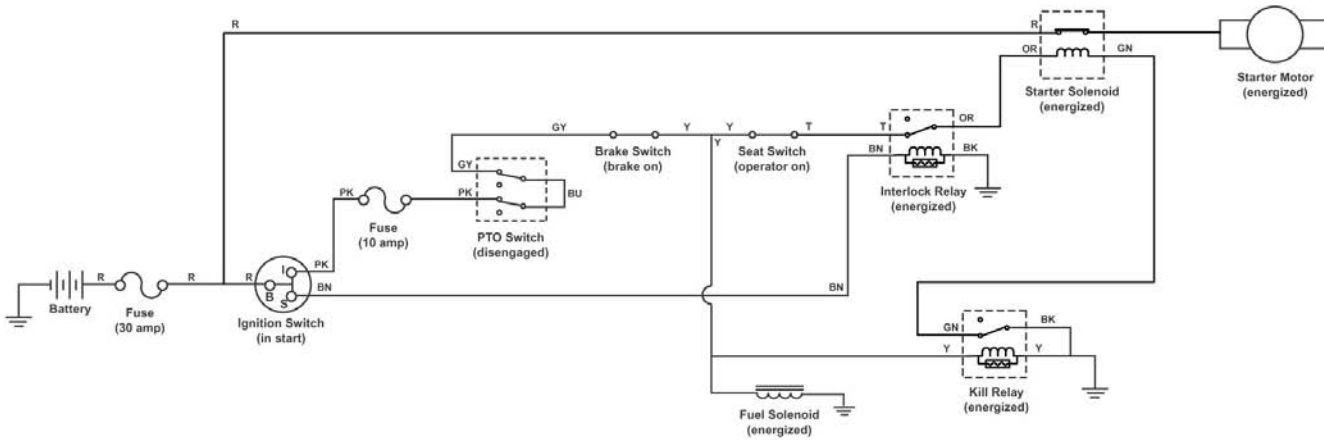

**Spark Circuit**  
(ignition switch in "start" position)

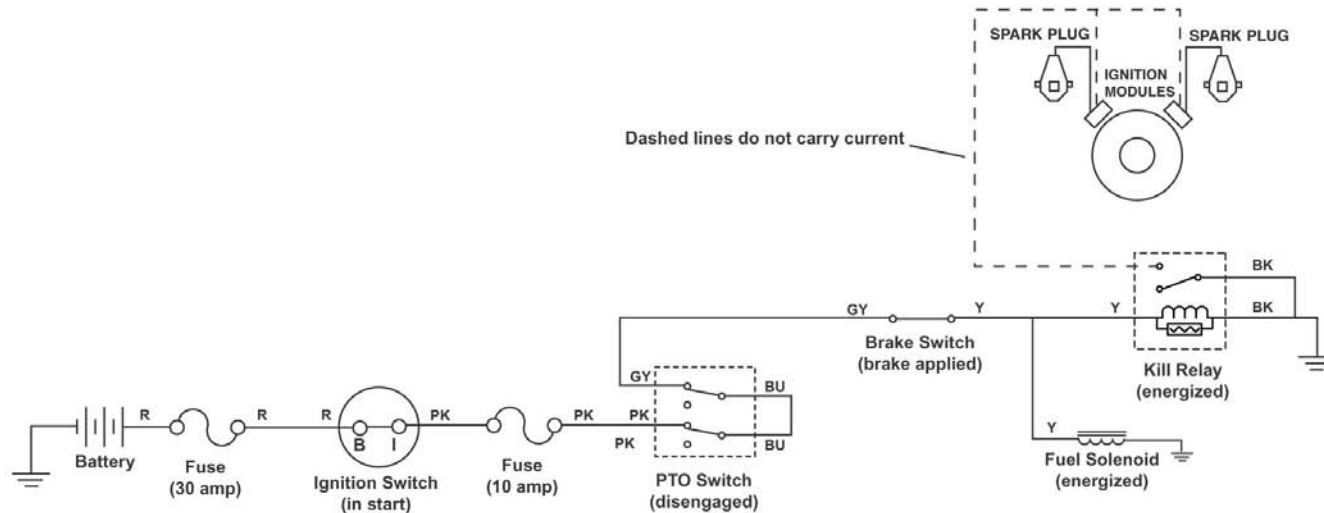

Circuits

Legend	
Black	Bk
Blue	Bu
Brown	Bn
Green	Gn
Grey	Gy
Orange	Or
Pink	Pk
Red	Re
Tan	T
Violet	Vio
White	W
Yellow	Y

**Spark Circuit**  
(ignition switch in "run")

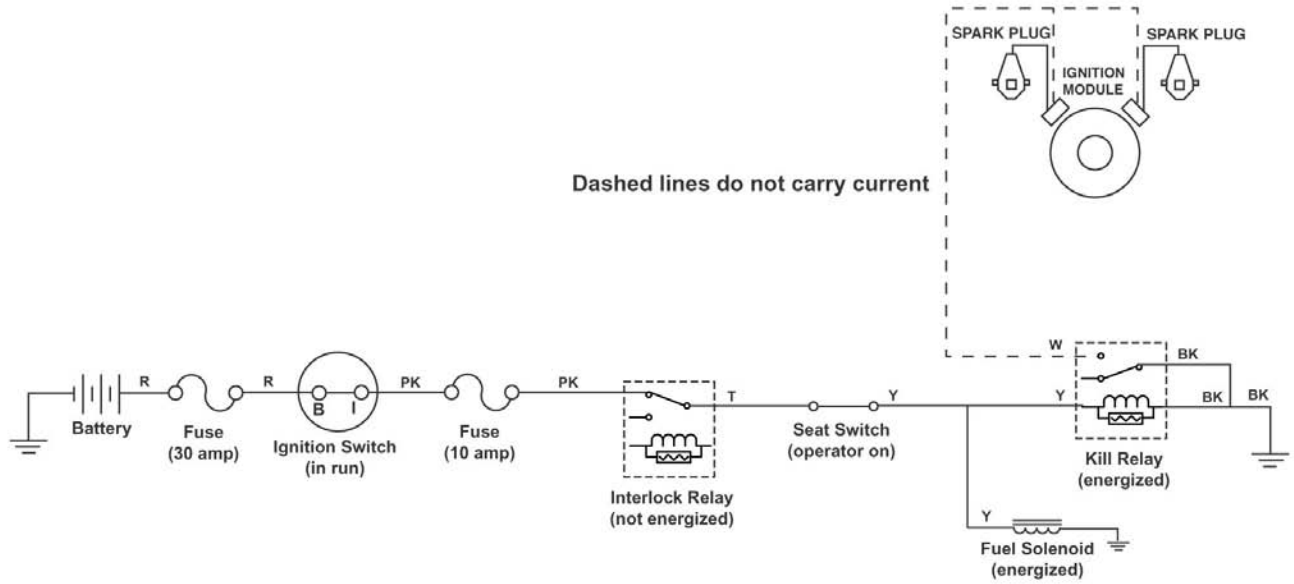

Legend	
Black	Bk
Blue	Bu
Brown	Bn
Green	Gn
Grey	Gy
Orange	Or
Pink	Pk
Red	Re
Tan	T
Violet	Vio
White	W
Yellow	Y

**Reverse Operating System Circuit**  
 (PTO "off", in forward)

Dashed lines do not carry current

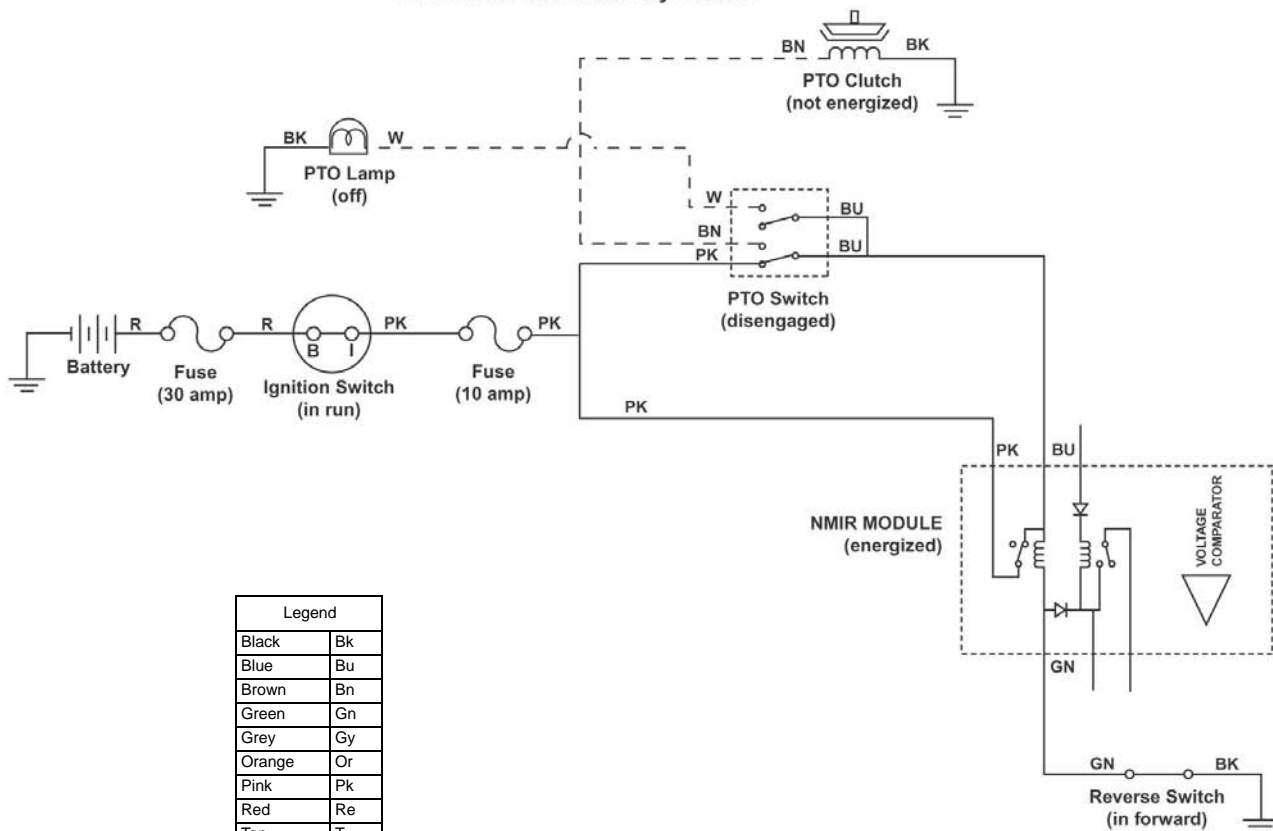

**Reverse Operating System Circuit**  
(PTO "on", in forward)

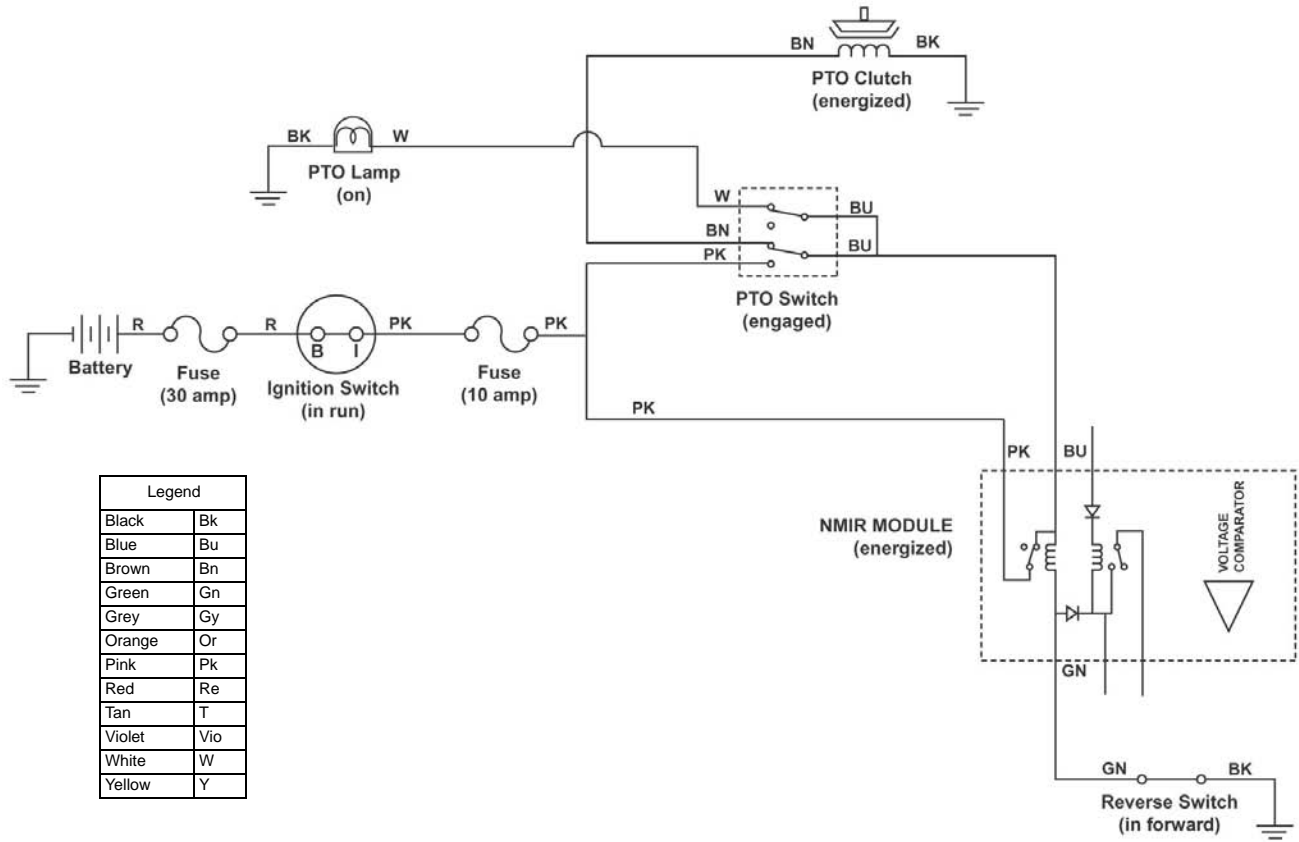

Legend	
Black	Bk
Blue	Bu
Brown	Bn
Green	Gn
Grey	Gy
Orange	Or
Pink	Pk
Red	Re
Tan	T
Violet	Vio
White	W
Yellow	Y

**Reverse Operating System Circuit**  
 (PTO "on", in reverse)

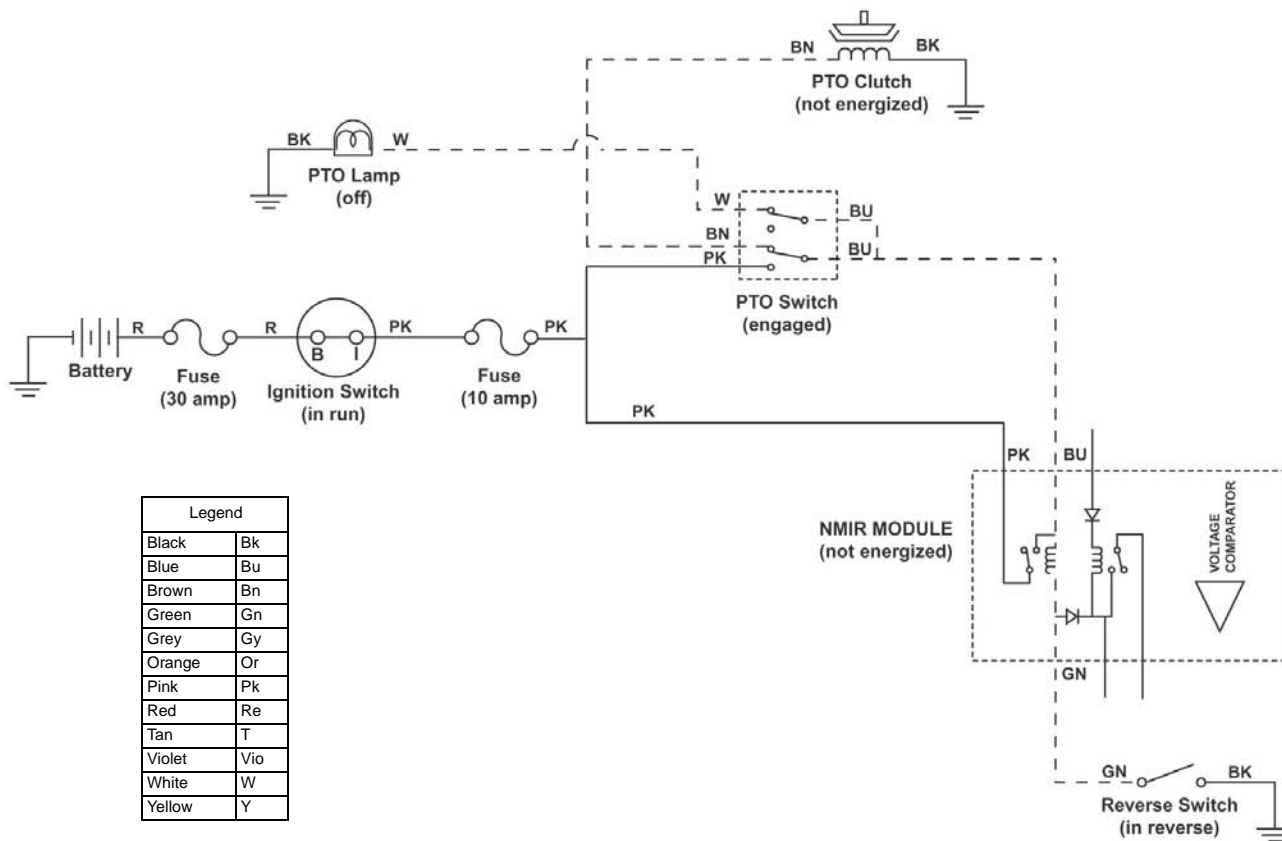

Legend	
Black	Bk
Blue	Bu
Brown	Bn
Green	Gn
Grey	Gy
Orange	Or
Pink	Pk
Red	Re
Tan	T
Violet	Vio
White	W
Yellow	Y

**Reverse Operating System Circuit**  
(Override key switch "activated")

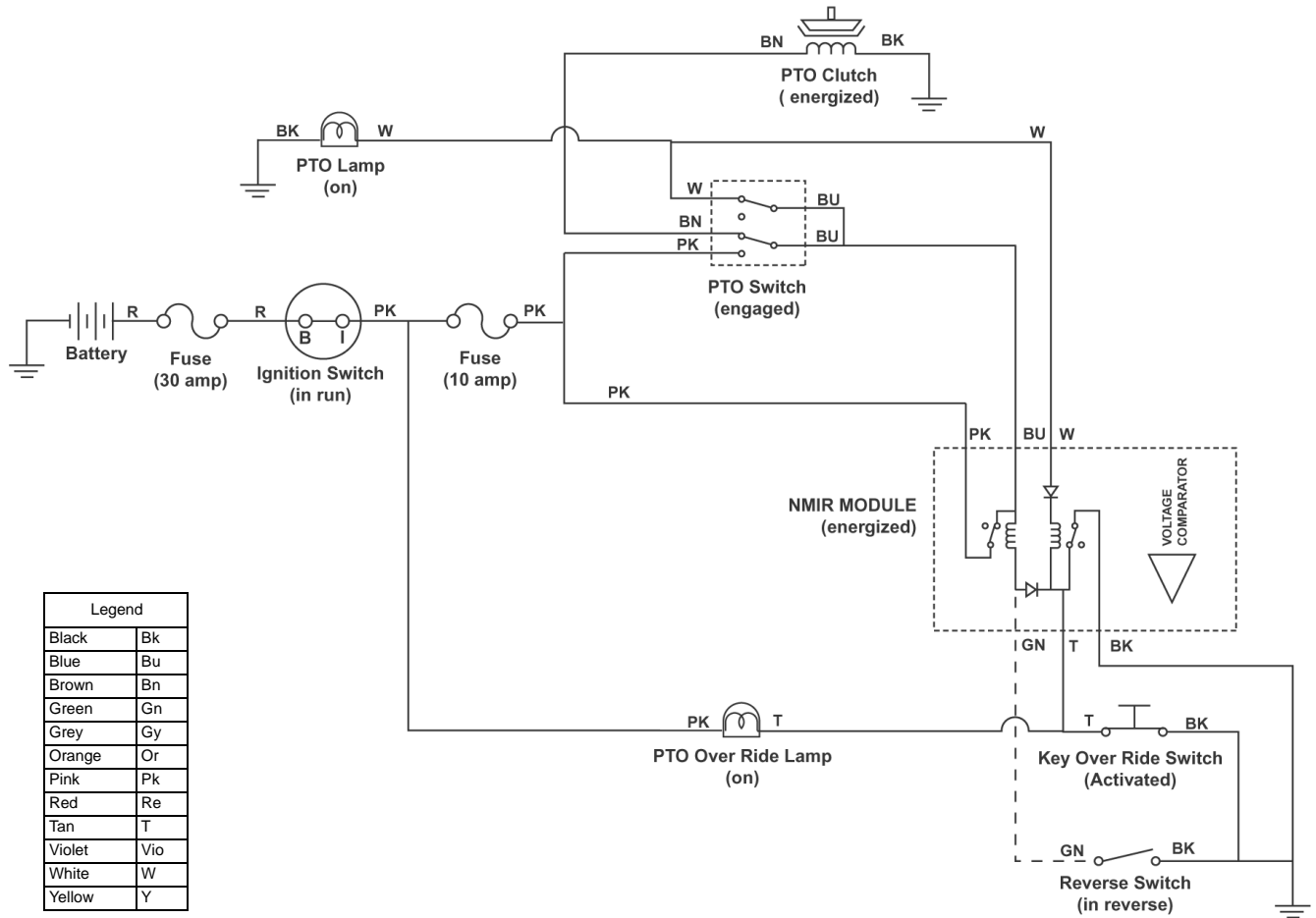

Legend	
Black	Bk
Blue	Bu
Brown	Bn
Green	Gn
Grey	Gy
Orange	Or
Pink	Pk
Red	Re
Tan	T
Violet	Vio
White	W
Yellow	Y

**Circuits**

**Reverse Operating System Circuit**

*(PTO "on", in reverse, override mode)*

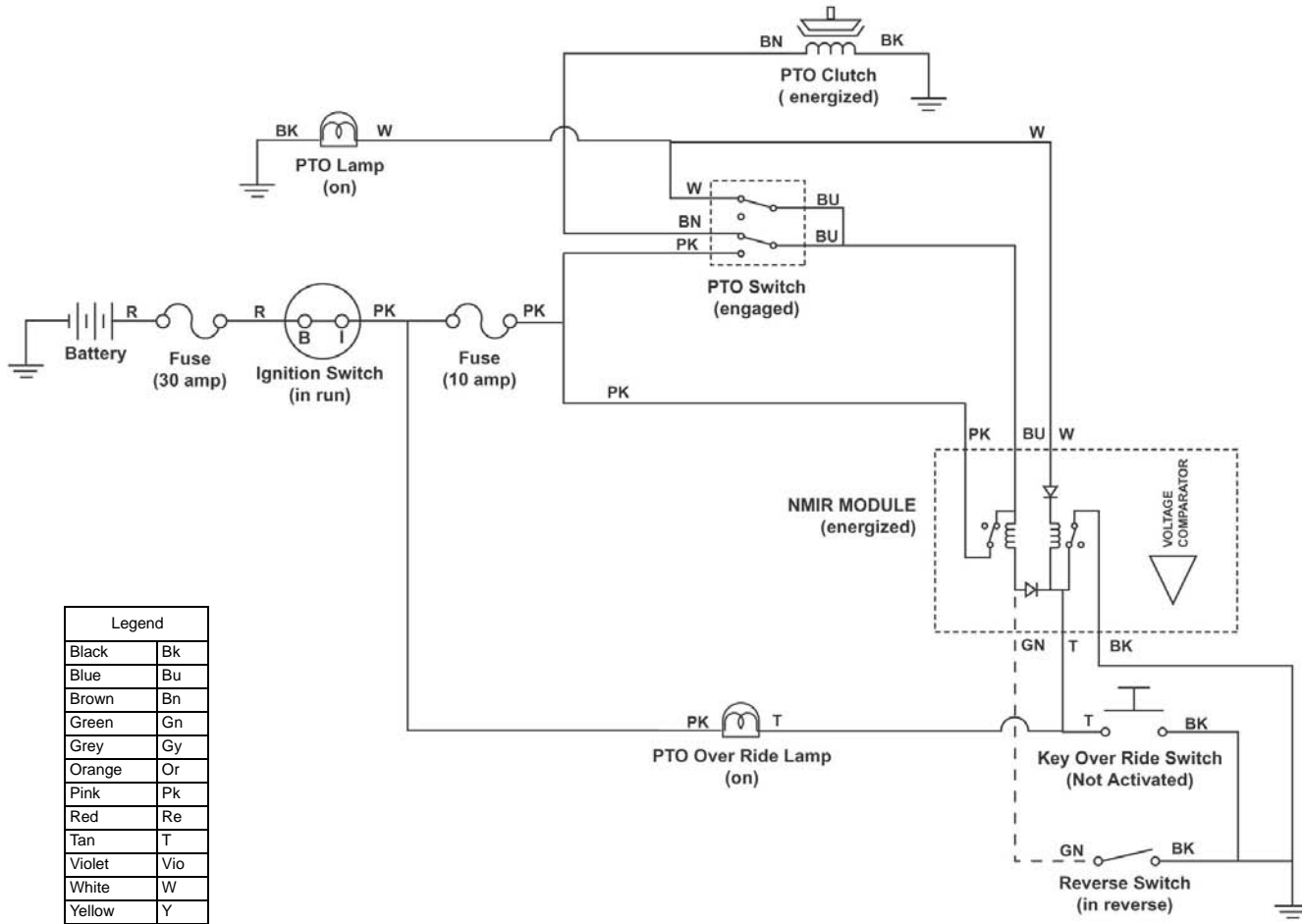

**Circuits**

**Light Circuit**

*(ignition switch in "run/lights")*

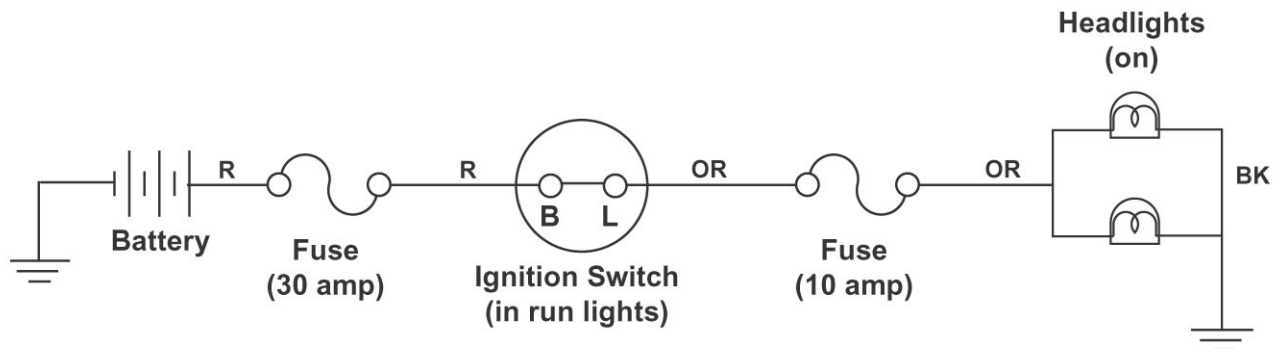



**Battery Charge Circuit**  
(ignition switch in "run")

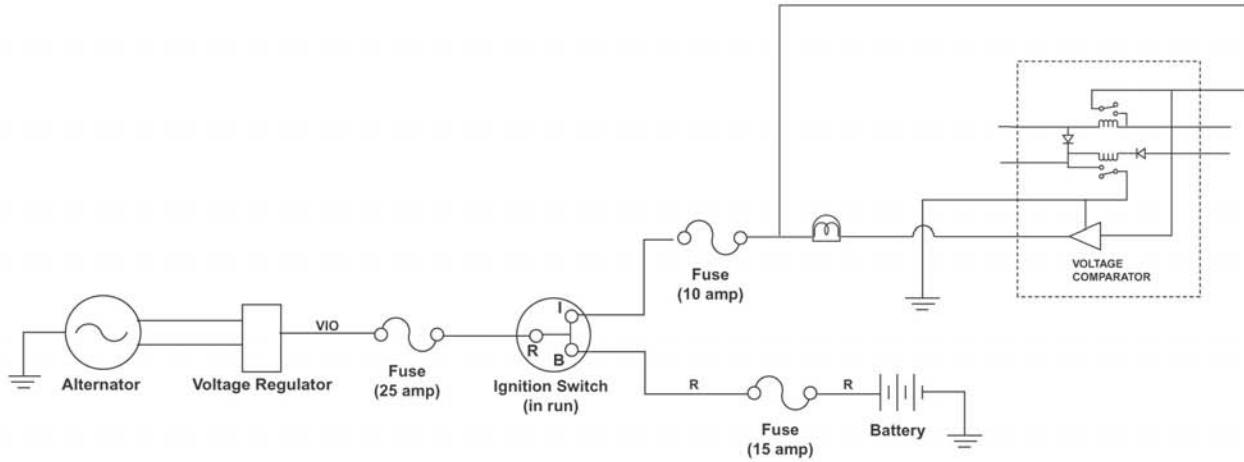

**Hourmeter Circuit**  
(ignition switch in "run")

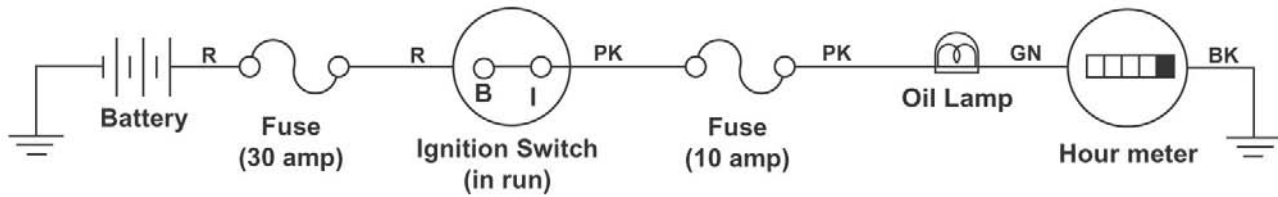

**Oil Pressure Light Circuit**  
(ignition switch in "run")

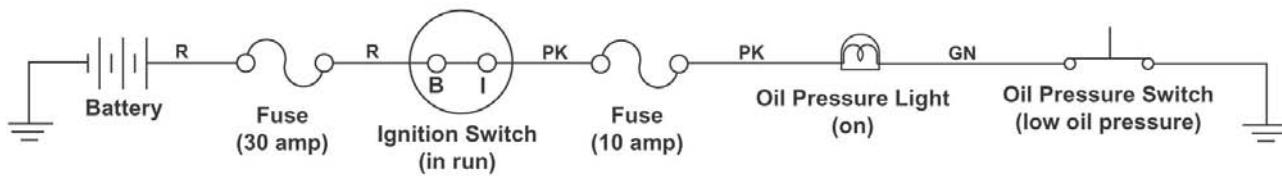

Legend	
Black	Bk
Blue	Bu
Brown	Bn
Green	Gn
Grey	Gy
Orange	Or
Pink	Pk
Red	Re
Tan	T
Violet	Vio
White	W
Yellow	Y

**Cruise Control Circuit**  
(ignition switch in "run")

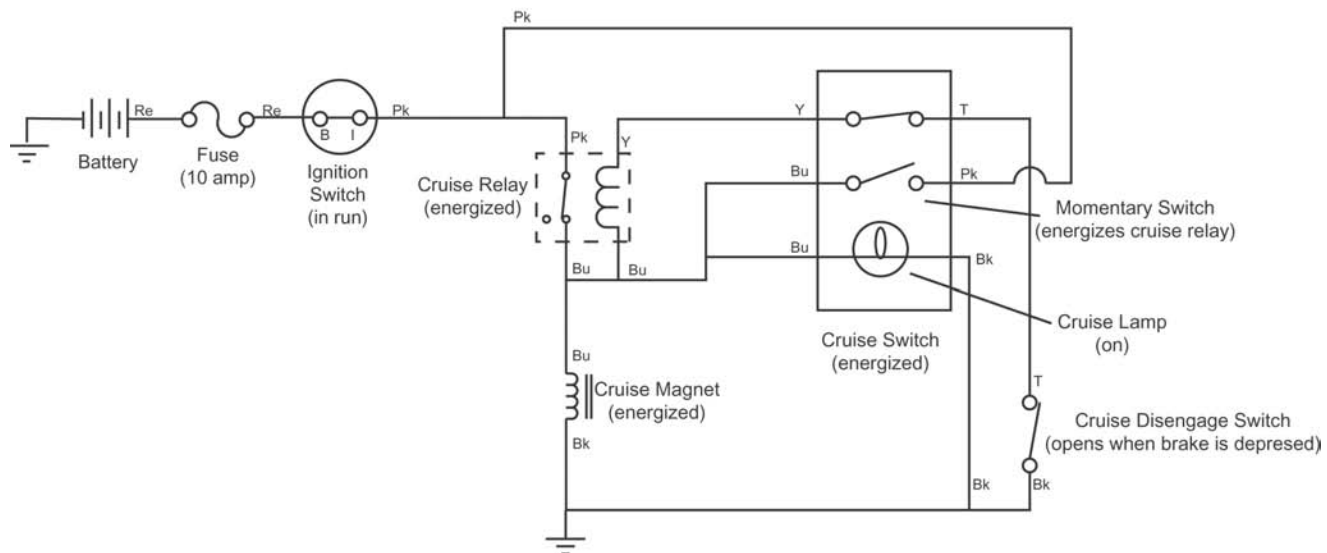

Legend	
Black	Bk
Blue	Bu
Brown	Bn
Green	Gn
Grey	Gy
Orange	Or
Pink	Pk
Red	Re
Tan	T
Violet	Vio
White	W
Yellow	Y



**419XT Information List (2003)**

Wiring Diagrams . . . . . 13-2 & 13-3

Circuit Diagrams

- Starter Motor Circuit . . . . . 13-4
- Spark Circuits . . . . . 13-4 & 13-5
- Reverse Operating System Circuits 13-6 - 13-10
- Light Circuit . . . . . 13-10
- Battery Charge Circuit . . . . . 13-11
- Hourmeter Circuit . . . . . 13-11
- Oil Pressure Light Circuit . . . . . 13-11
- Lift Pump Circuit . . . . . 13-12
- Cruise Control Circuit . . . . . 13-12

Wiring Diagram

Wiring Diagram

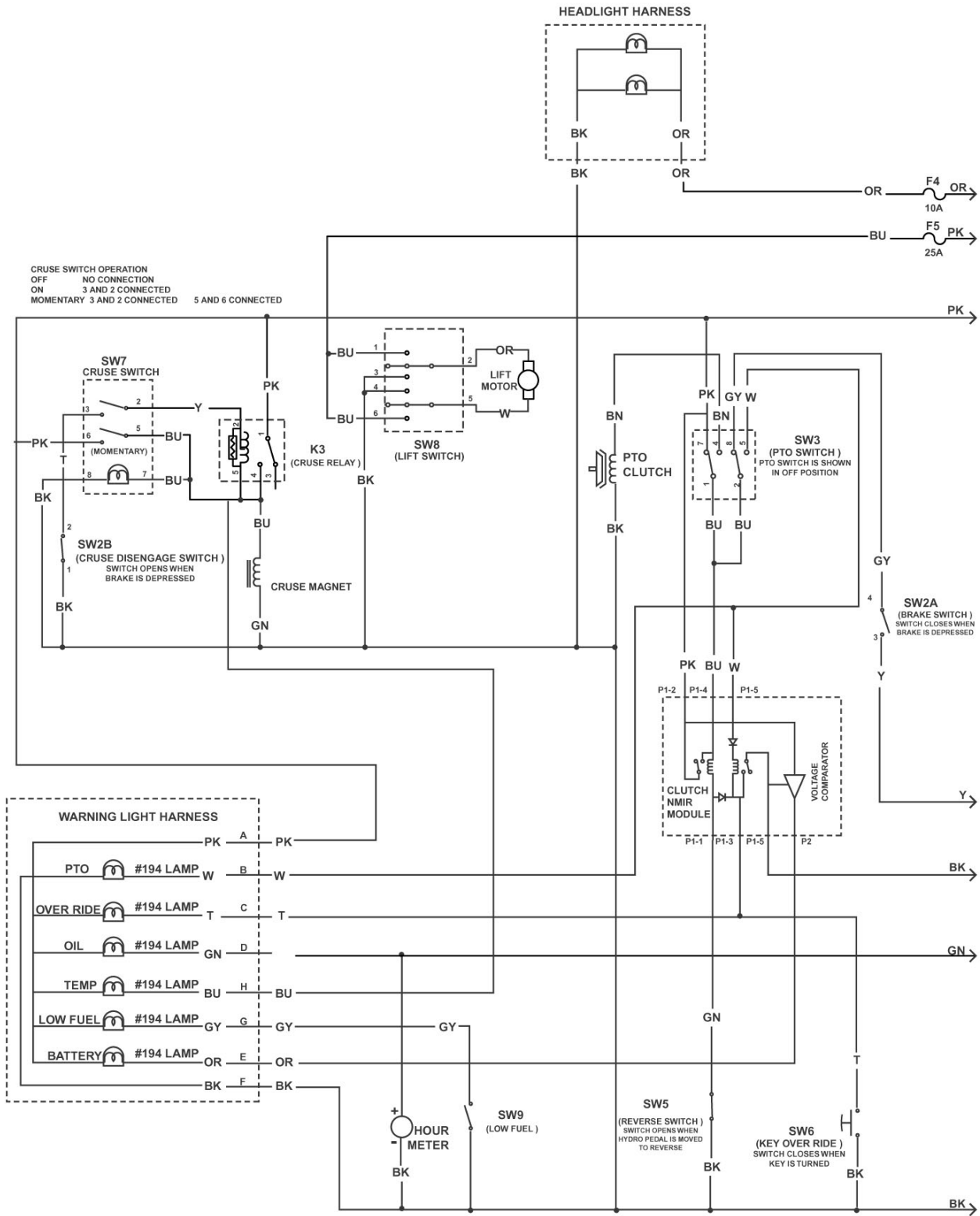

Wiring Diagram

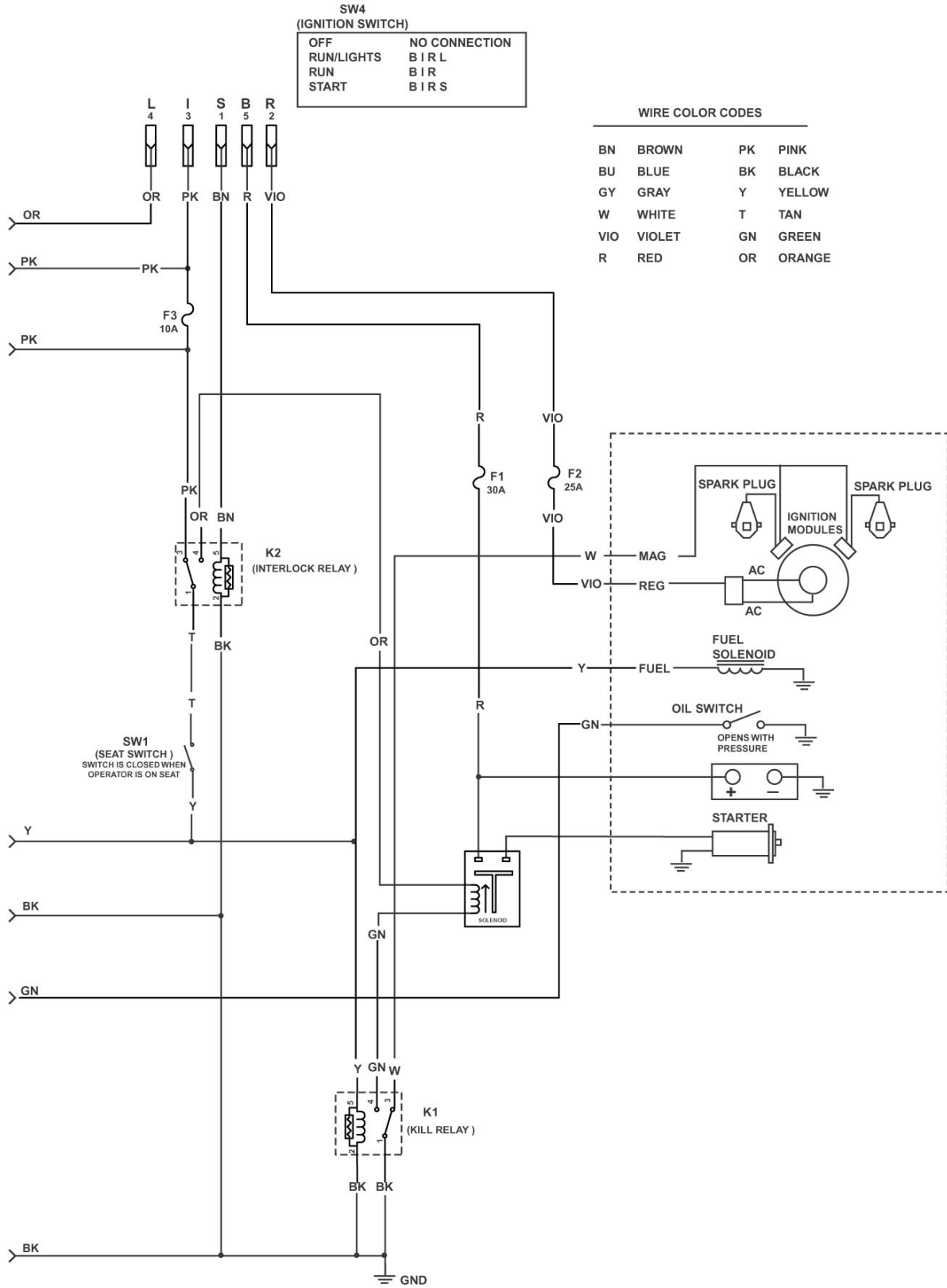

Wiring Diagram

**Starter Motor Circuit**  
(ignition switch in "start")

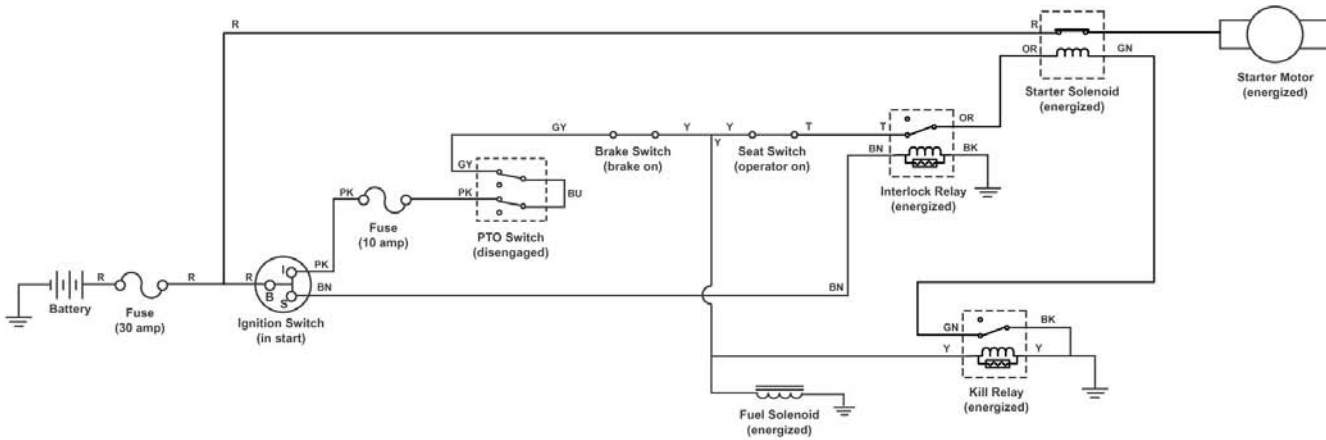

**Spark Circuit**  
(ignition switch in "start" position)

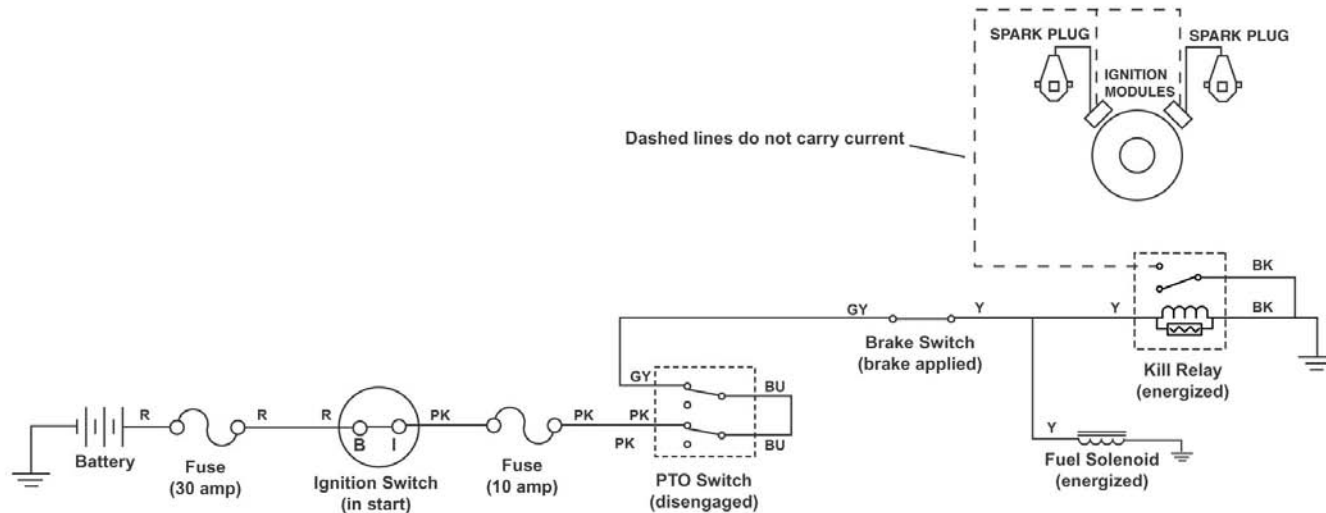

Legend	
Black	Bk
Blue	Bu
Brown	Bn
Green	Gn
Grey	Gy
Orange	Or
Pink	Pk
Red	Re
Tan	T
Violet	Vio
White	W
Yellow	Y

**Spark Circuit**  
(ignition switch in "run")

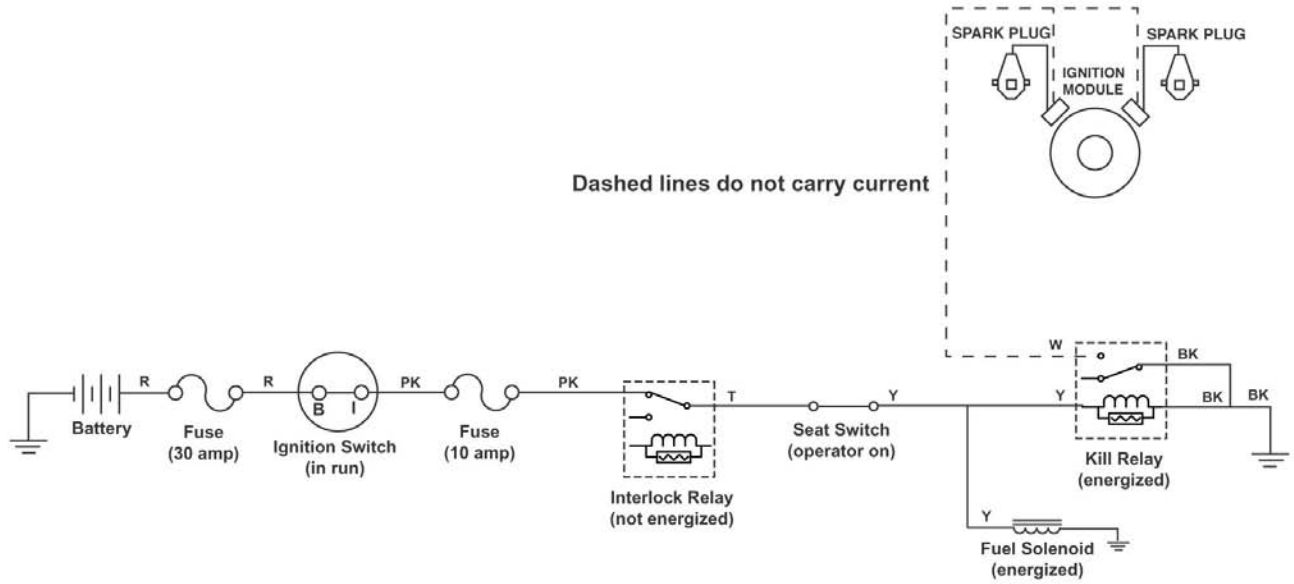

Legend	
Black	Bk
Blue	Bu
Brown	Bn
Green	Gn
Grey	Gy
Orange	Or
Pink	Pk
Red	Re
Tan	T
Violet	Vio
White	W
Yellow	Y

**Reverse Operating System Circuit**  
 (PTO "off", in forward)

Dashed lines do not carry current

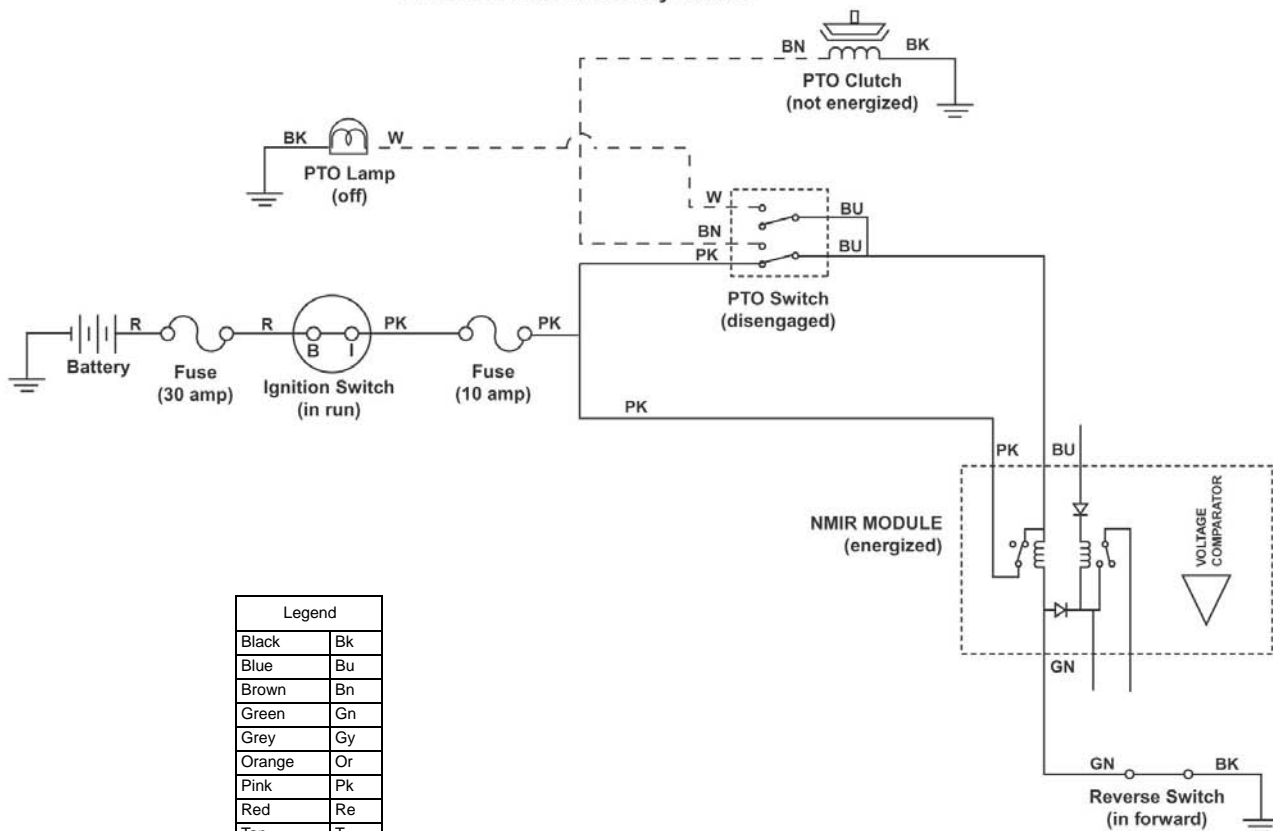

Legend	
Black	Bk
Blue	Bu
Brown	Bn
Green	Gn
Grey	Gy
Orange	Or
Pink	Pk
Red	Re
Tan	T
Violet	Vio
White	W
Yellow	Y



**Reverse Operating System Circuit**  
(PTO "on", in forward)

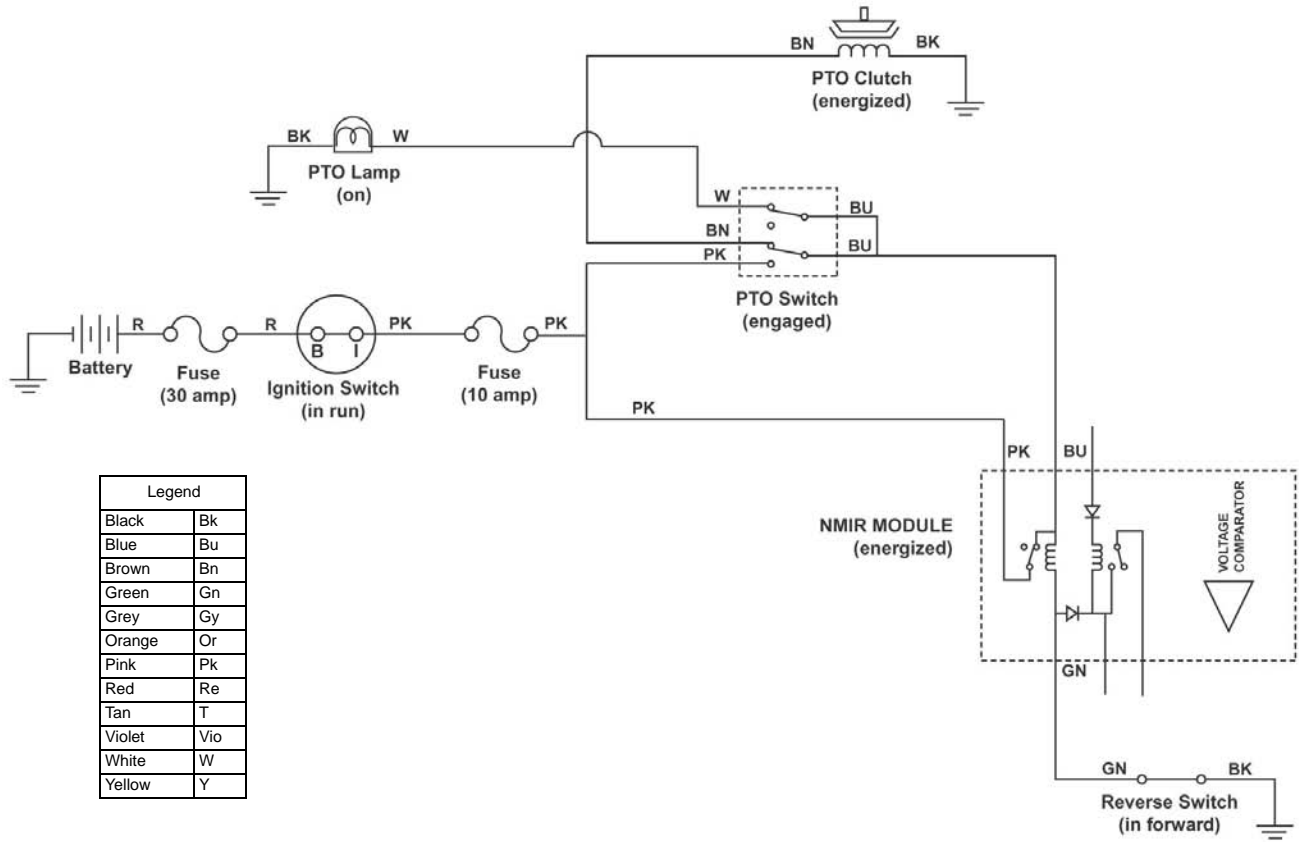

**Reverse Operating System Circuit**  
*(PTO "on", in reverse)*

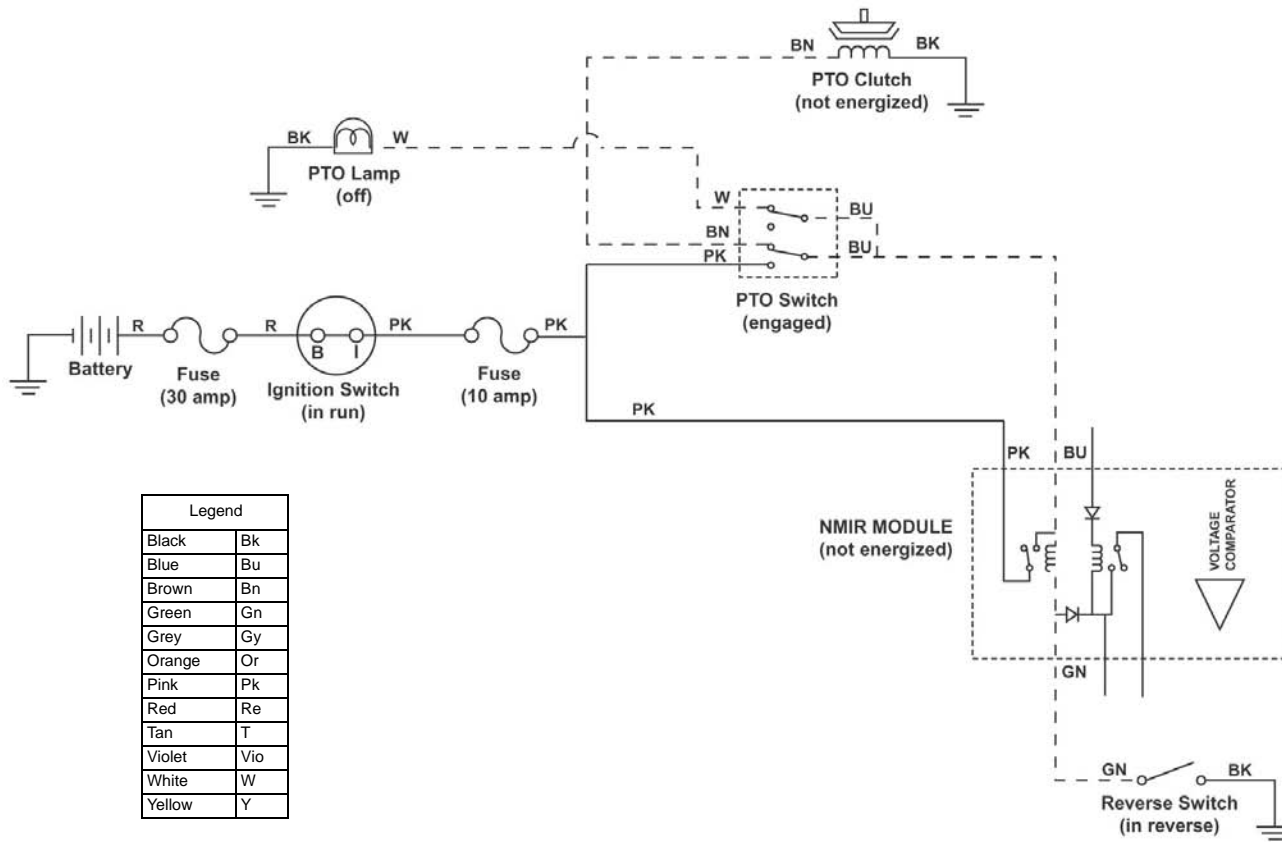

**Reverse Operating System Circuit**  
(Override key switch "activated")

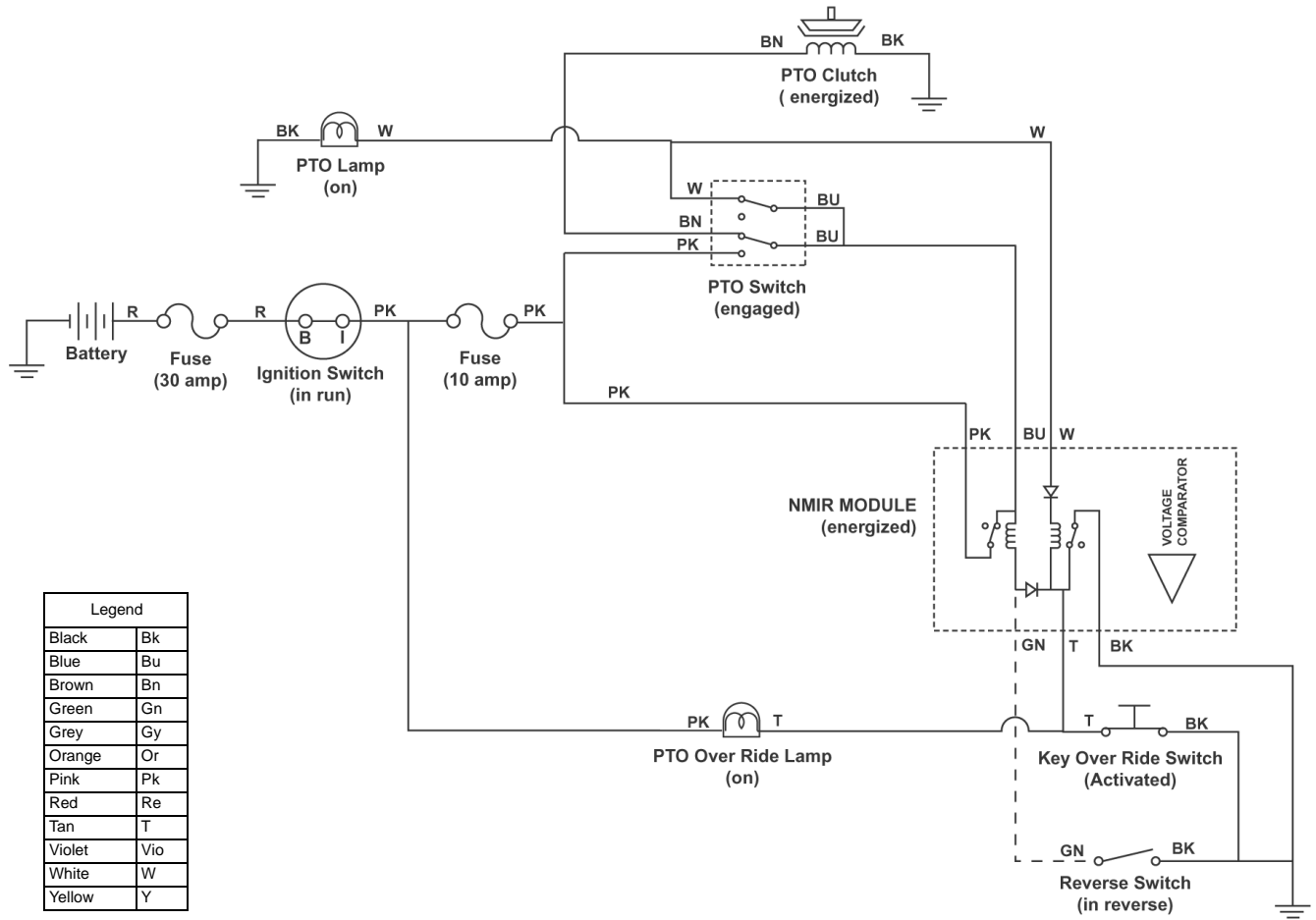

Legend	
Black	Bk
Blue	Bu
Brown	Bn
Green	Gn
Grey	Gy
Orange	Or
Pink	Pk
Red	Re
Tan	T
Violet	Vio
White	W
Yellow	Y

**Circuits**

**Reverse Operating System Circuit**

(PTO "on", in reverse, override mode)

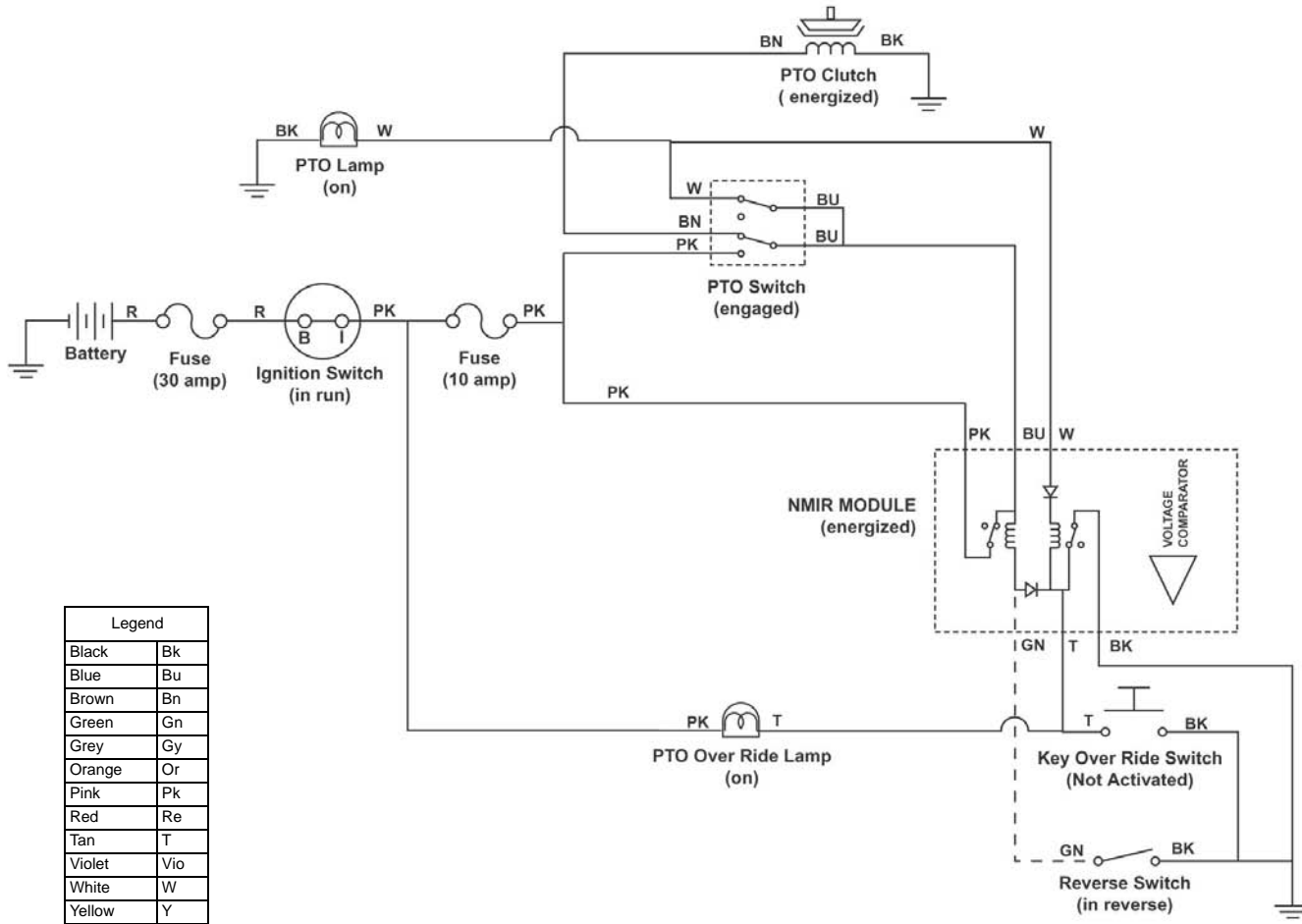

Legend	
Black	Bk
Blue	Bu
Brown	Bn
Green	Gn
Grey	Gy
Orange	Or
Pink	Pk
Red	Re
Tan	T
Violet	Vio
White	W
Yellow	Y

**Circuits**

**Light Circuit**

(ignition switch in "run/lights")

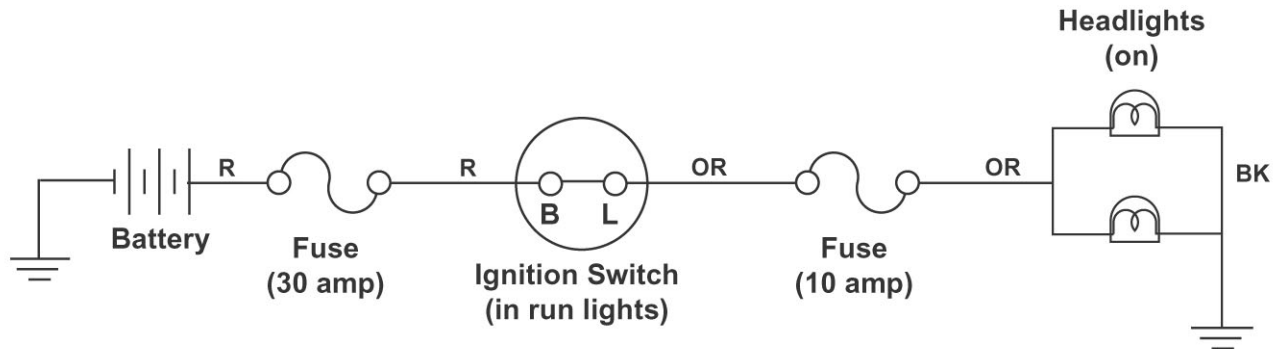

**Battery Charge Circuit**  
(ignition switch in "run")

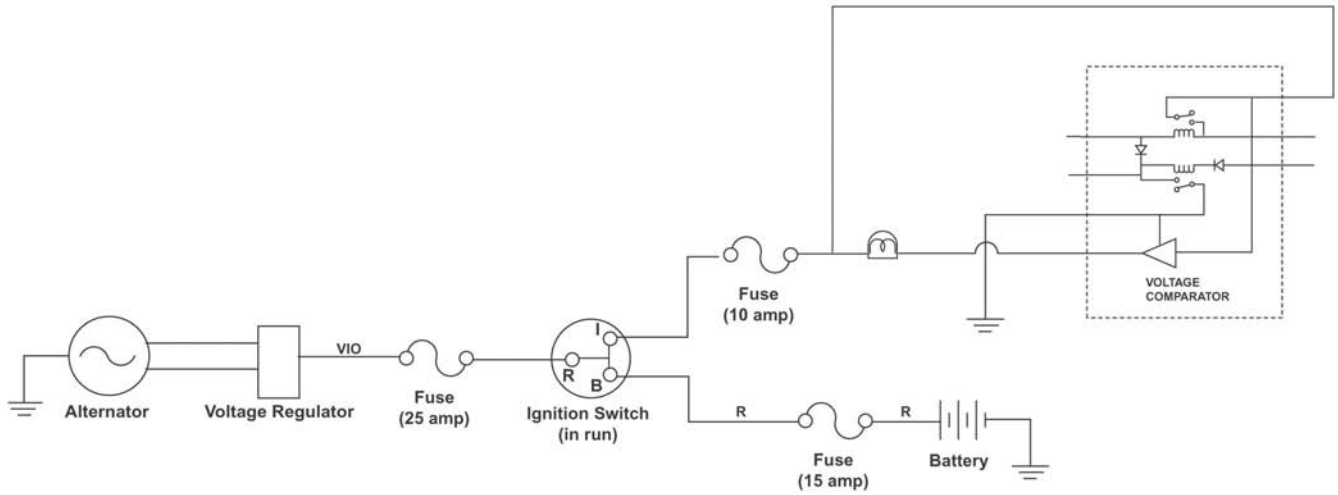

**Hourmeter Circuit**  
(ignition switch in "run")

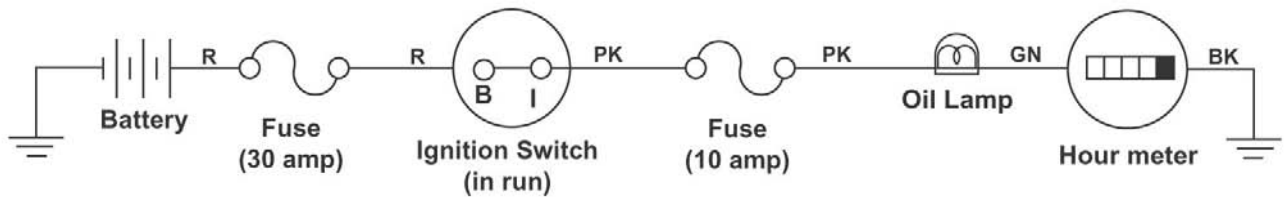

**Oil Pressure Light Circuit**  
(ignition switch in "run")

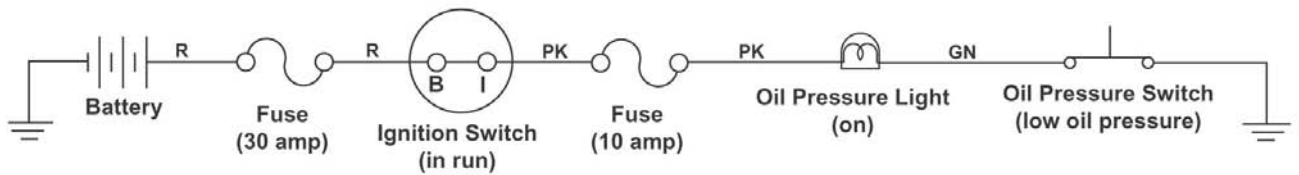

Legend	
Black	Bk
Blue	Bu
Brown	Bn
Green	Gn
Grey	Gy
Orange	Or
Pink	Pk
Red	Re
Tan	T
Violet	Vio
White	W
Yellow	Y

**Lift Pump Circuit**  
(ignition switch in "run")

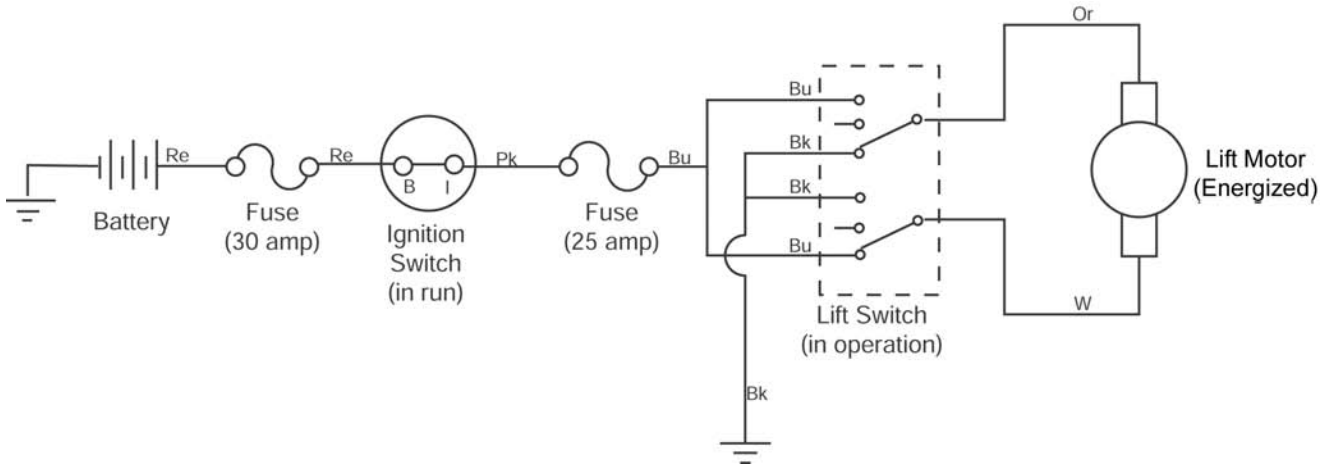

**Cruise Control Circuit**  
(ignition switch in "run")

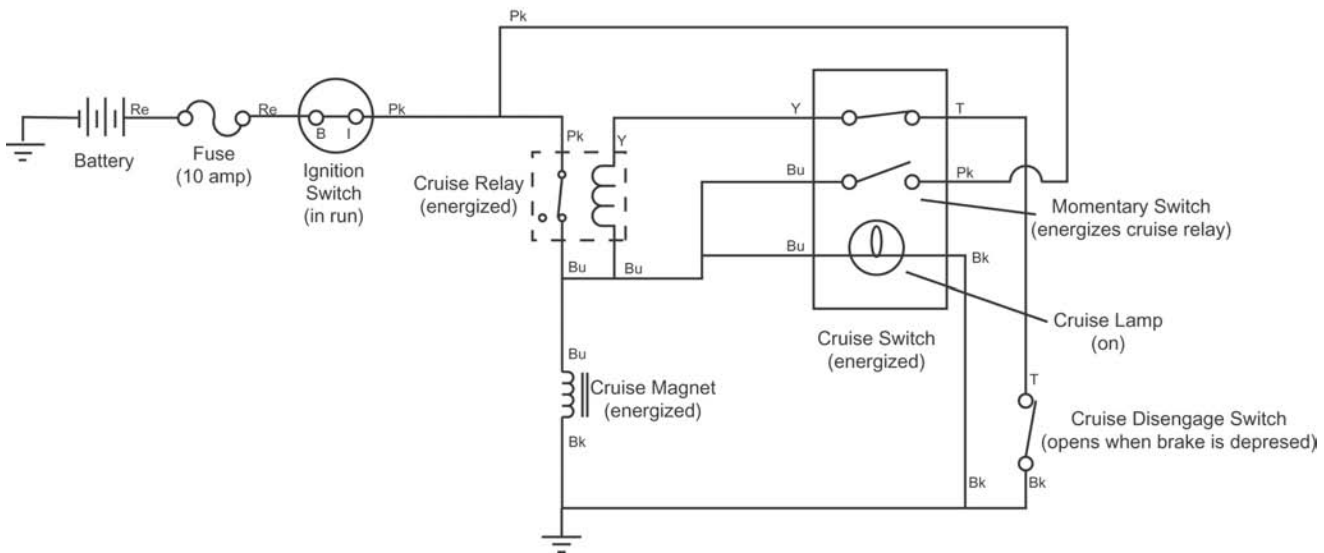

Legend	
Black	Bk
Blue	Bu
Brown	Bn
Green	Gn
Grey	Gy
Orange	Or
Pink	Pk
Red	Re
Tan	T
Violet	Vio
White	W
Yellow	Y



**5xi Information List (2002 - 2003)**

Wiring Diagrams . . . . . 14-2 & 14-3

Circuit Diagrams

- Starter Motor Circuit . . . . . 14-4
- Spark Circuits . . . . . 14-4 & 14-5
- Reverse Operating System Circuits 14-6 - 14-10
- Charging Circuit . . . . . 14-10
- Hourmeter Circuit . . . . . 14-11
- Light Circuit . . . . . 14-11
- Gauge Circuit . . . . . 14-11
- Cruise Control Circuits . . . . . 14-12 - 14-16
- Park Light Circuit . . . . . 14-15

Wiring Diagram

Wiring Diagram

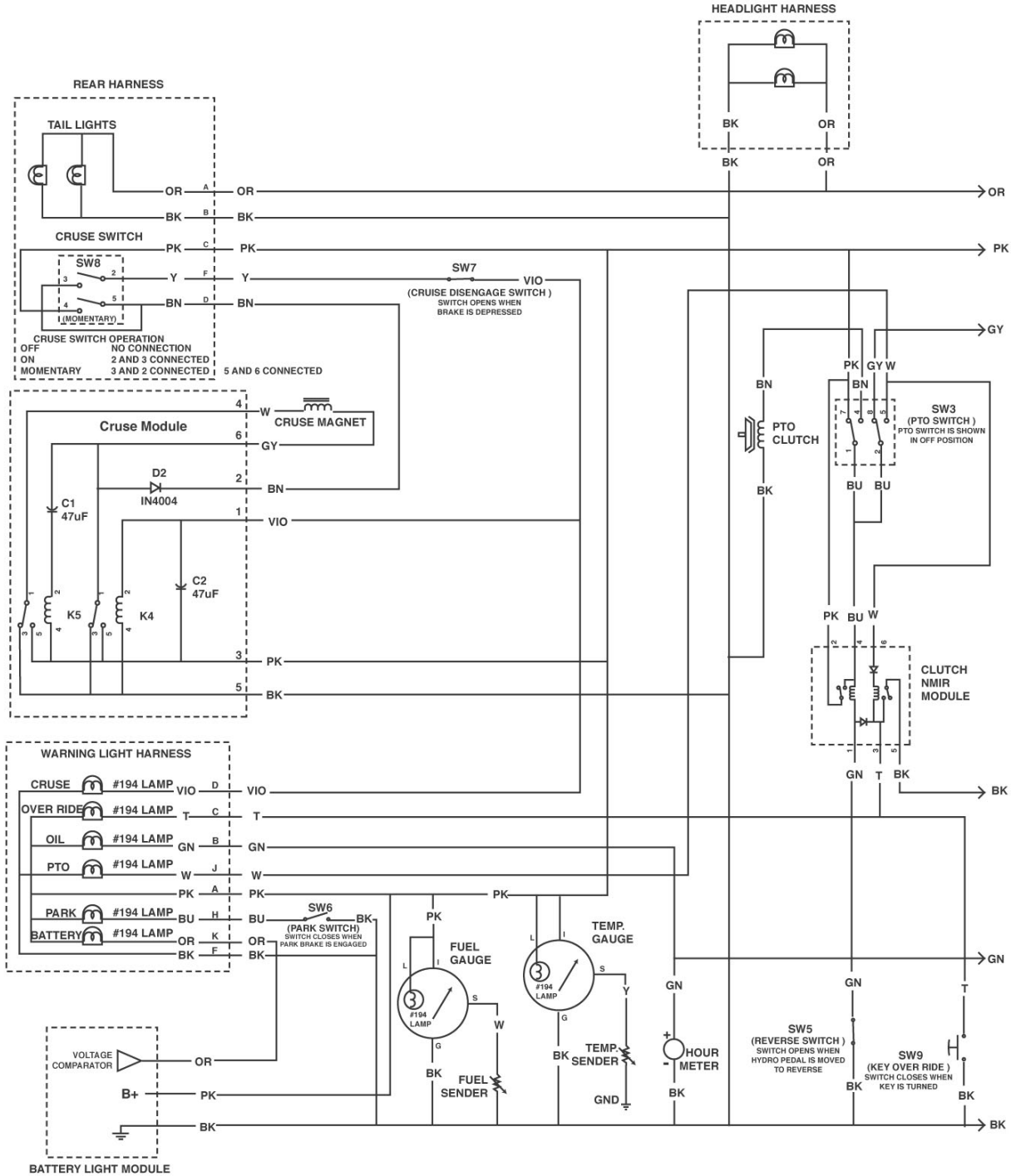



Wiring Diagram

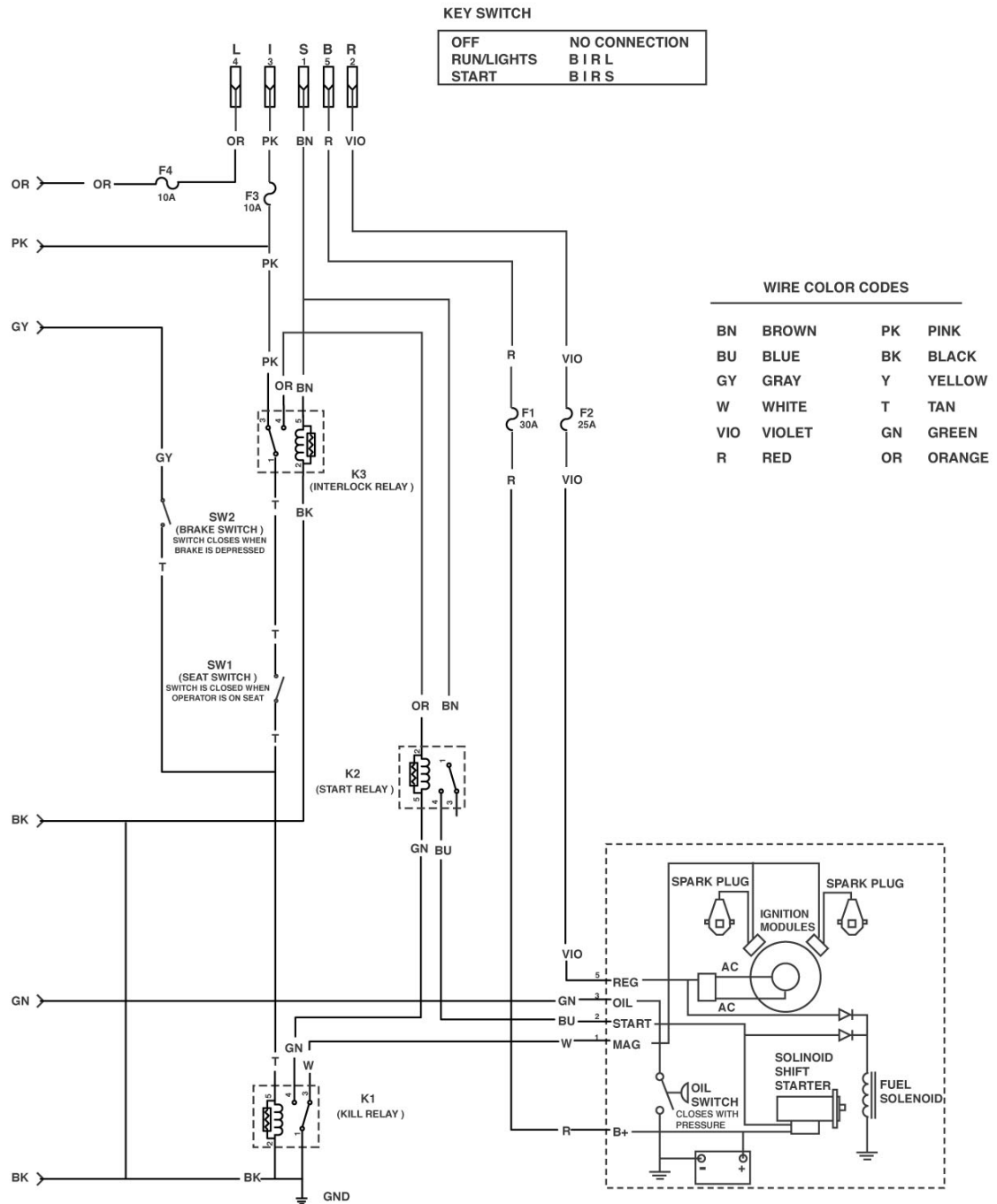

Wiring Diagram

**Starter Motor Circuit**  
(ignition switch in "start")

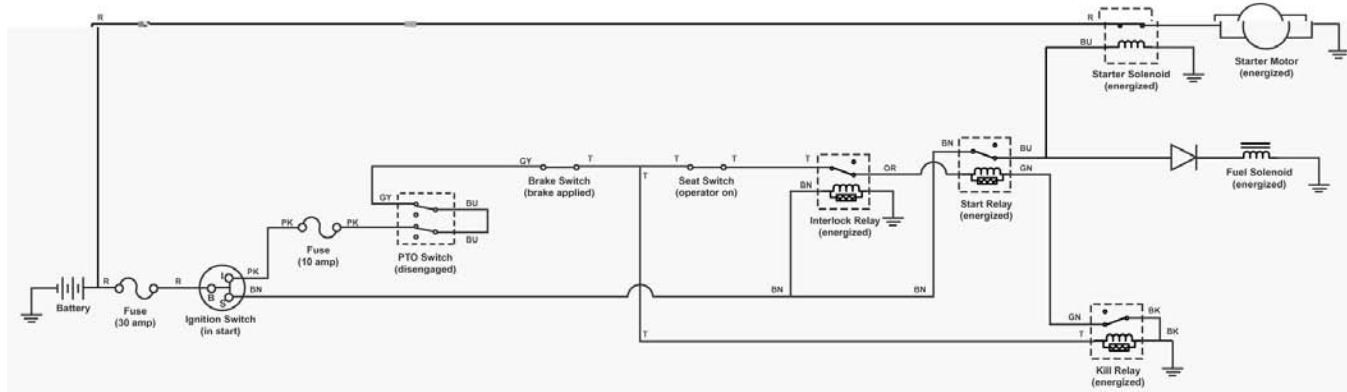

**Spark Circuit**  
(ignition switch in "start" position)

Legend	
Black	Bk
Blue	Bu
Brown	Bn
Green	Gn
Grey	Gy
Orange	Or
Pink	Pk
Red	Re
Tan	T
Violet	Vio
White	W
Yellow	Y

Dashed lines do not carry current

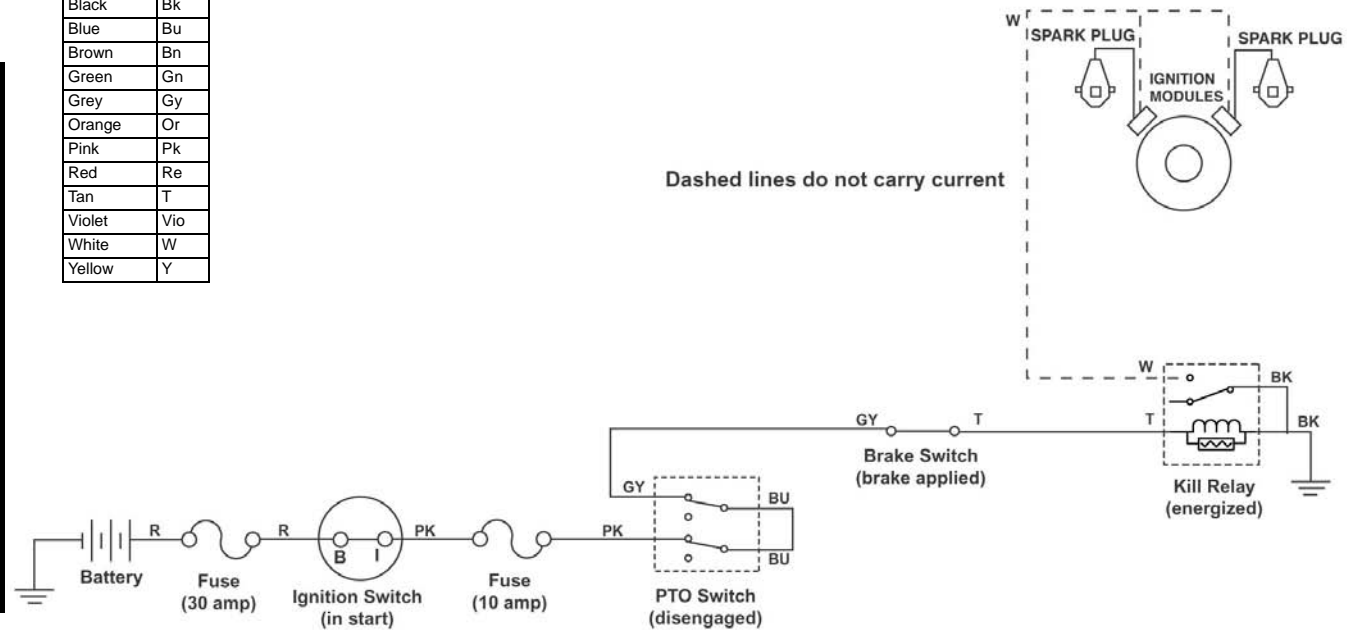

**Spark Circuit**  
(ignition switch in "run")

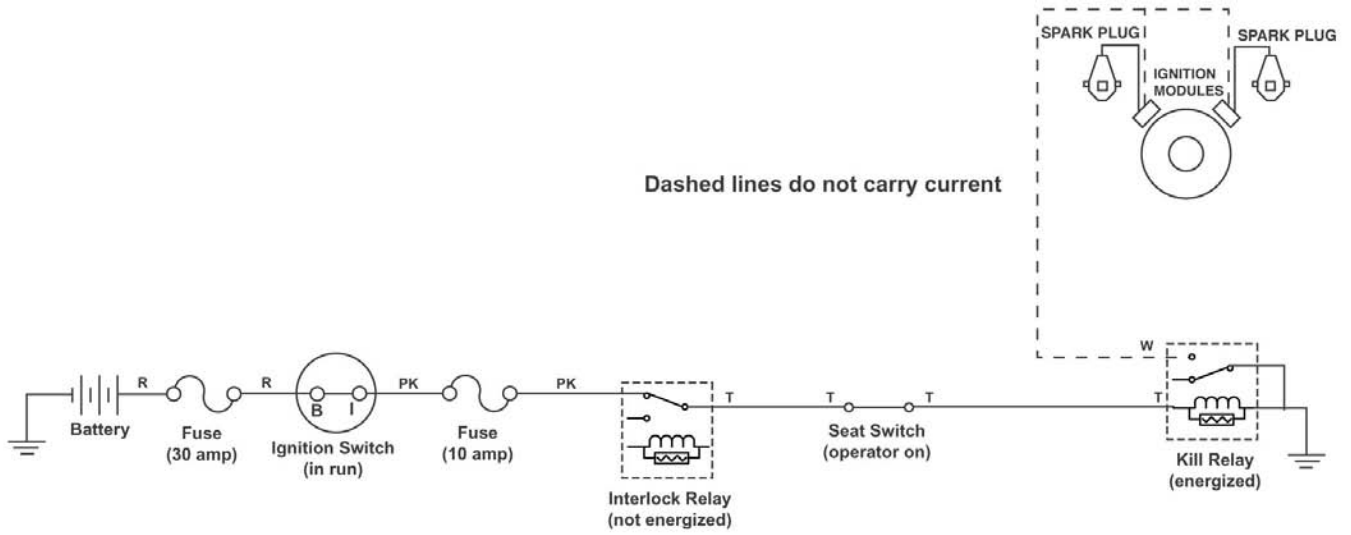

Legend	
Black	Bk
Blue	Bu
Brown	Bn
Green	Gn
Grey	Gy
Orange	Or
Pink	Pk
Red	Re
Tan	T
Violet	Vio
White	W
Yellow	Y

**Reverse Operating System Circuit**  
 (PTO "off", in forward)

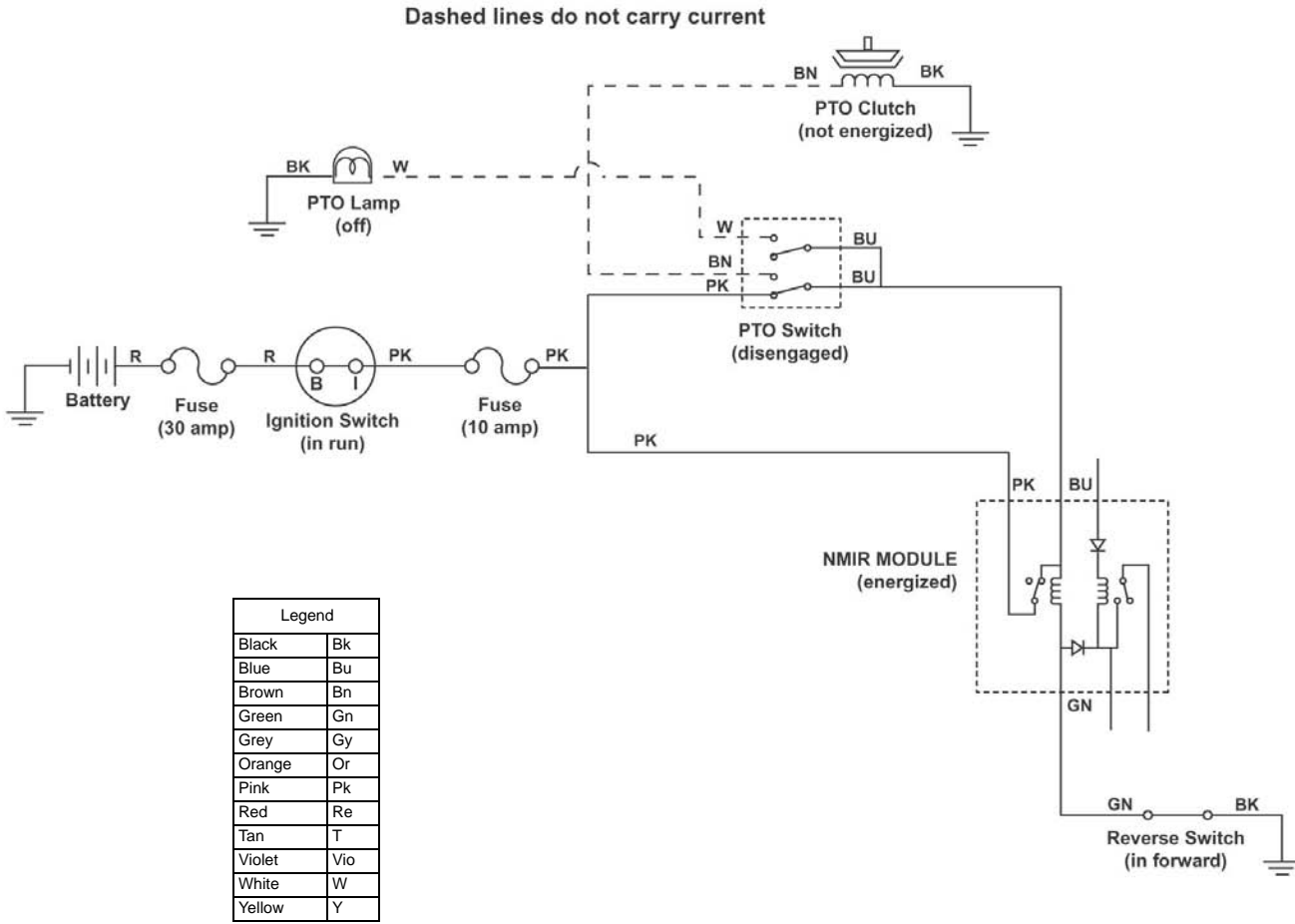

**Reverse Operating System Circuit**  
(PTO "on", in forward)

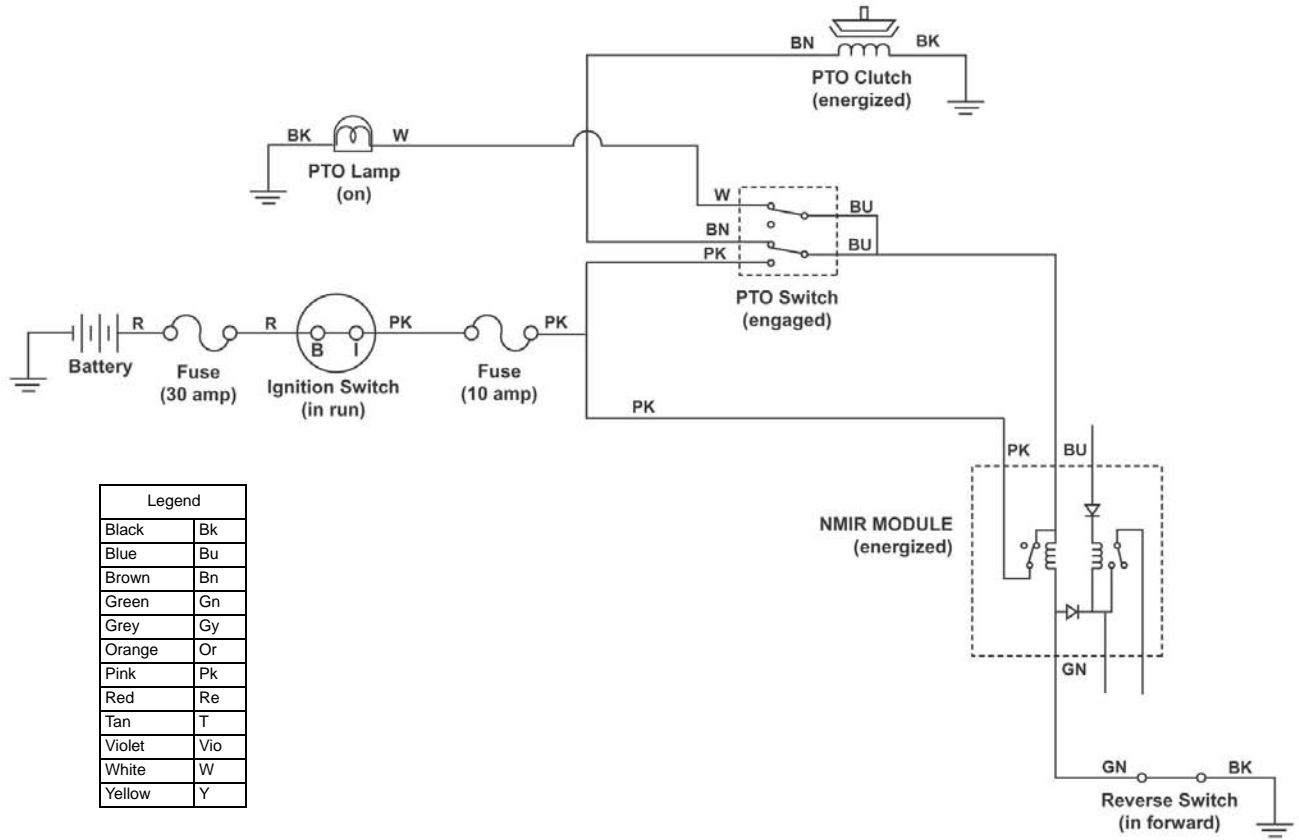

Legend	
Black	Bk
Blue	Bu
Brown	Bn
Green	Gn
Grey	Gy
Orange	Or
Pink	Pk
Red	Re
Tan	T
Violet	Vio
White	W
Yellow	Y

**Circuits**

**Reverse Operating System Circuit**  
*(PTO "on", in reverse)*

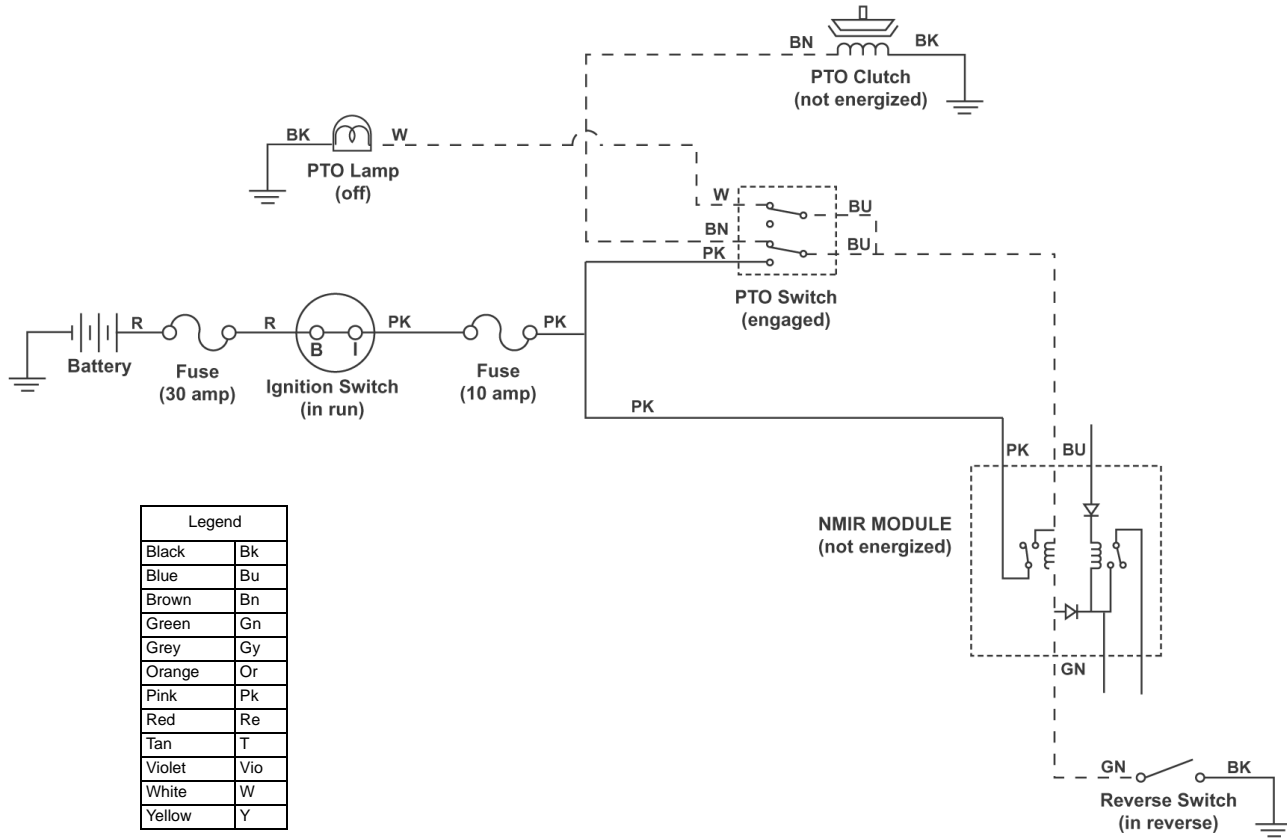

**Reverse Operating System Circuit**  
*(Override key switch "activated")*

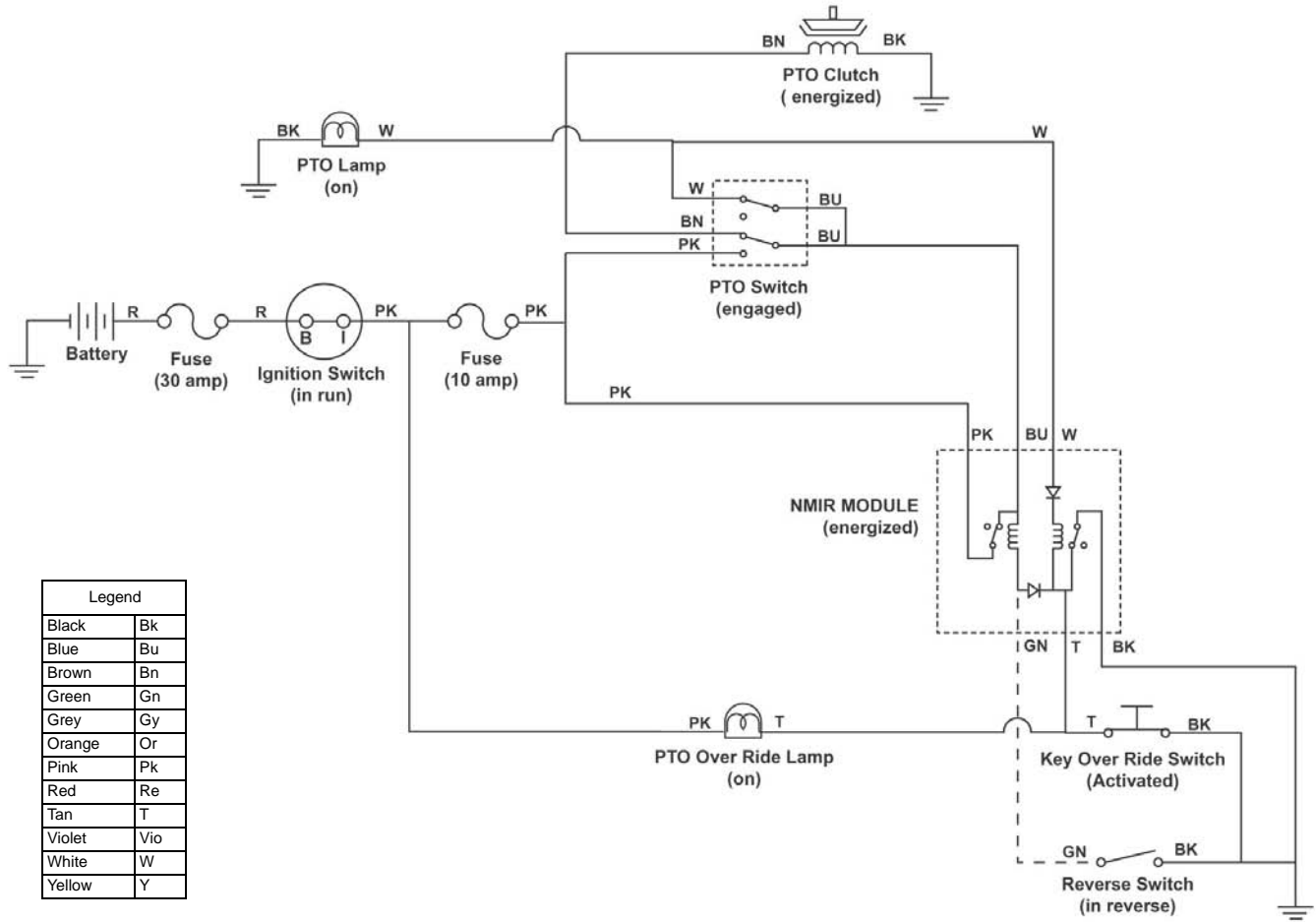

Legend	
Black	Bk
Blue	Bu
Brown	Bn
Green	Gn
Grey	Gy
Orange	Or
Pink	Pk
Red	Re
Tan	T
Violet	Vio
White	W
Yellow	Y

**Circuits**

**Reverse Operating System Circuit**

(PTO "on", in reverse, override mode)

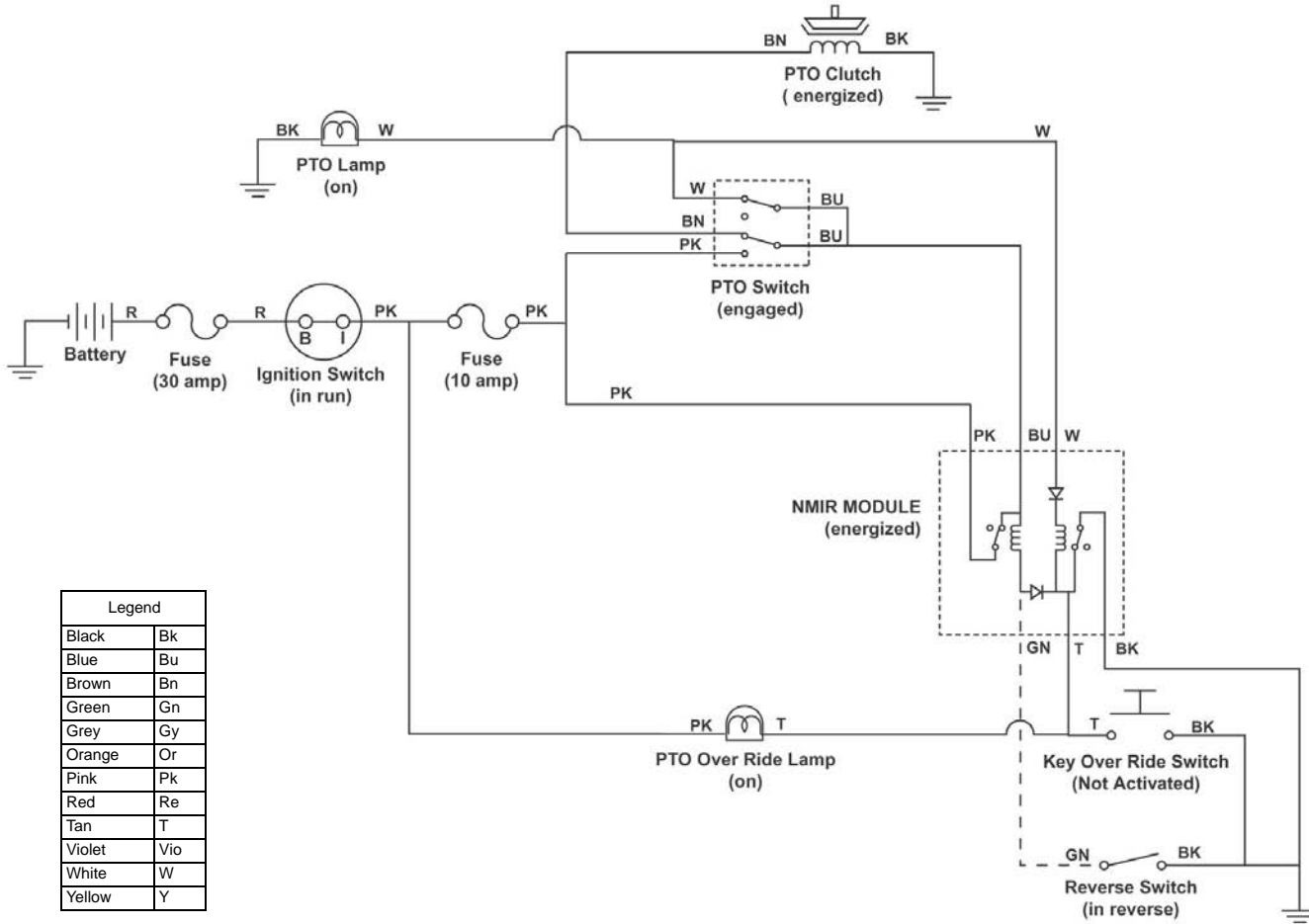

**Circuits**

**Charging Circuit**

(ignition switch in "run")

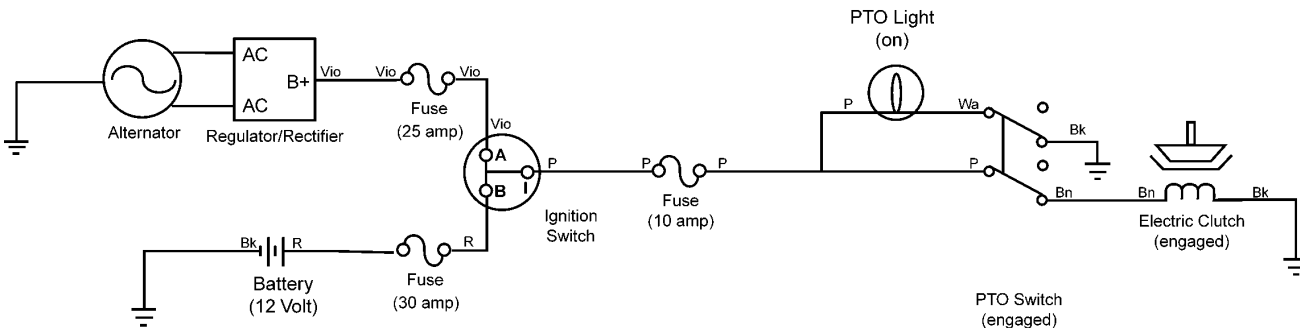



**Hourmeter Circuit**  
(ignition switch in "run")

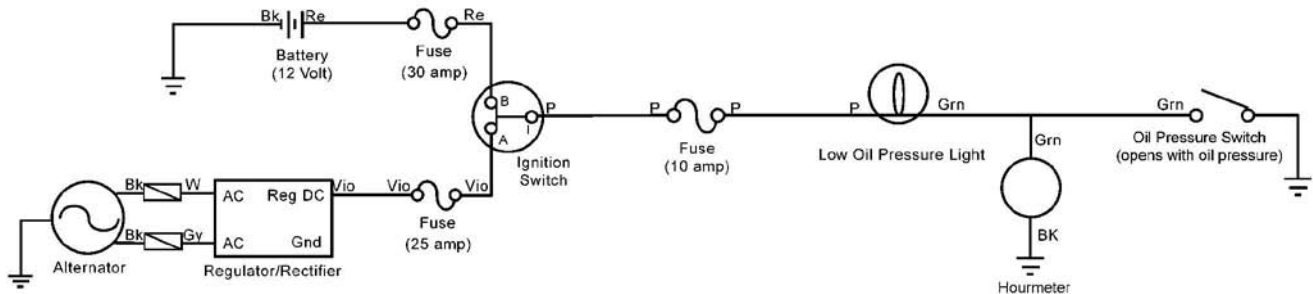

Note: Hourmeter will not operate with low oil pressure

**Light Circuit**  
(ignition switch in "run/lights")

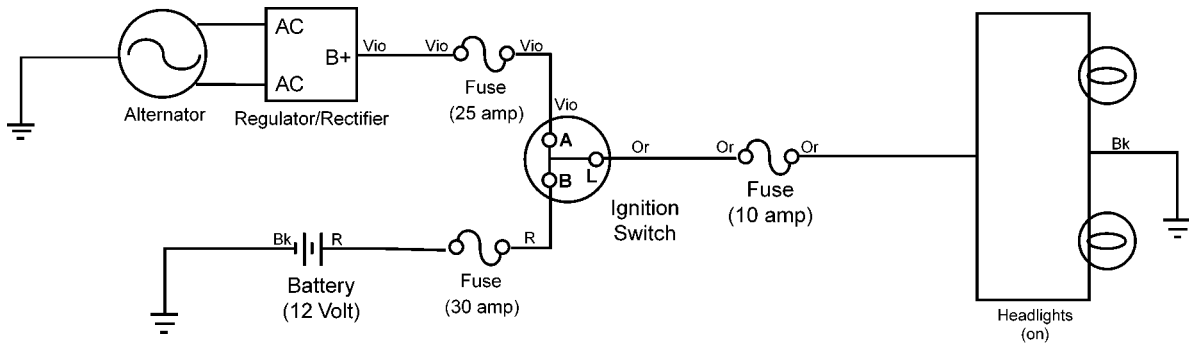

**Gauge Circuit**  
(ignition switch in "run")

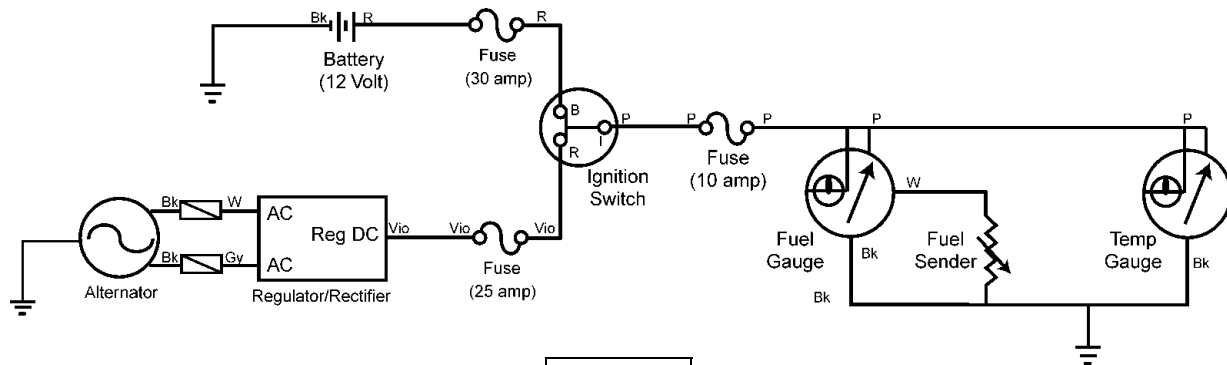

Legend	
Black	Bk
Blue	Bu
Brown	Bn
Green	Gn
Grey	Gy
Orange	Or
Pink	Pk
Red	Re
Tan	T
Violet	Vio
White	W
Yellow	Y

**Cruise Control Circuit**

(cruise "off"/ignition switch in "run")

Legend	
Black	Bk
Blue	Bu
Brown	Bn
Green	Gn
Grey	Gy
Orange	Or
Pink	Pk
Red	Re
Tan	T
Violet	Vio
White	W
Yellow	Y

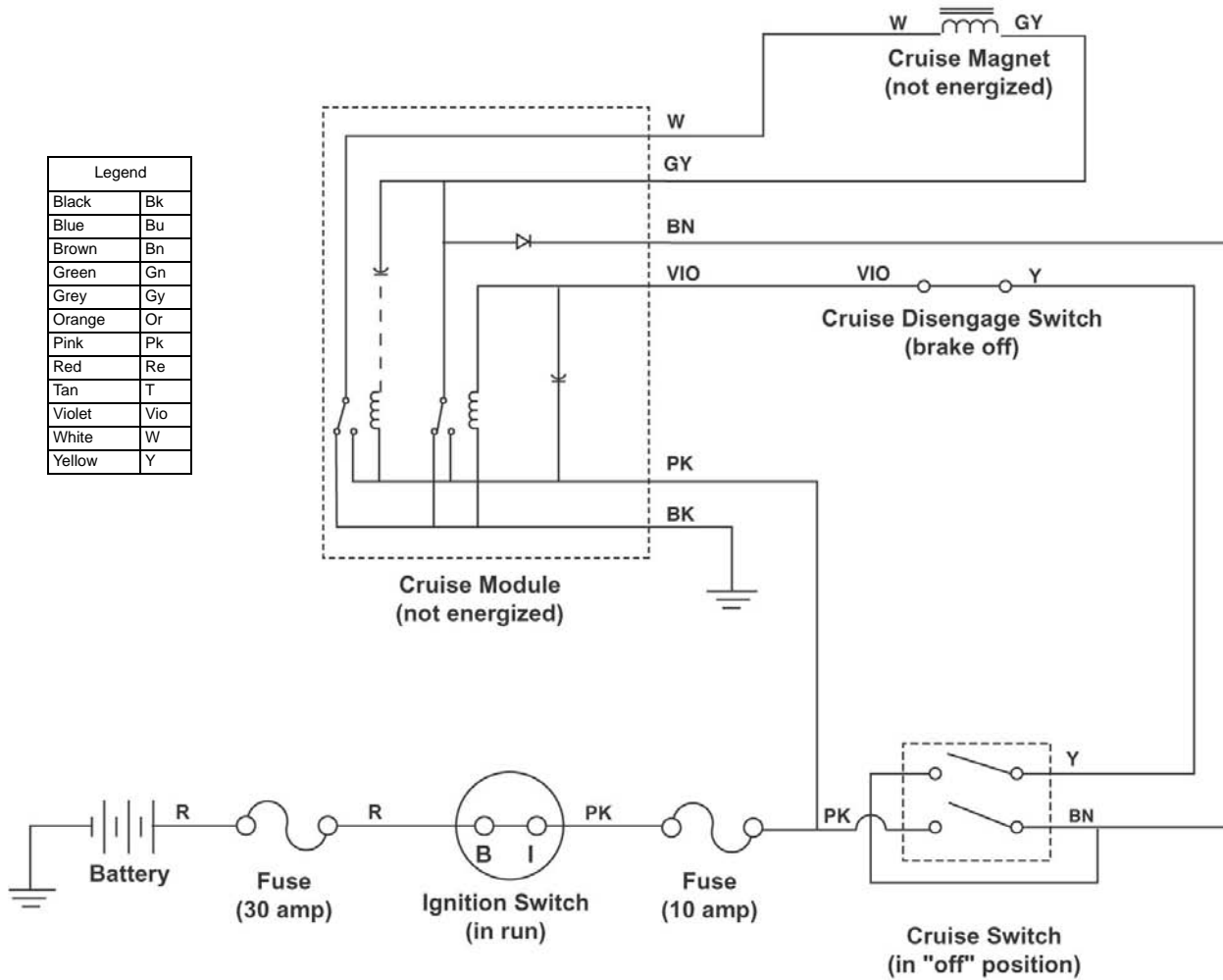

**Cruise Control Circuit**  
*(cruise "activated"/ignition switch in "run")*

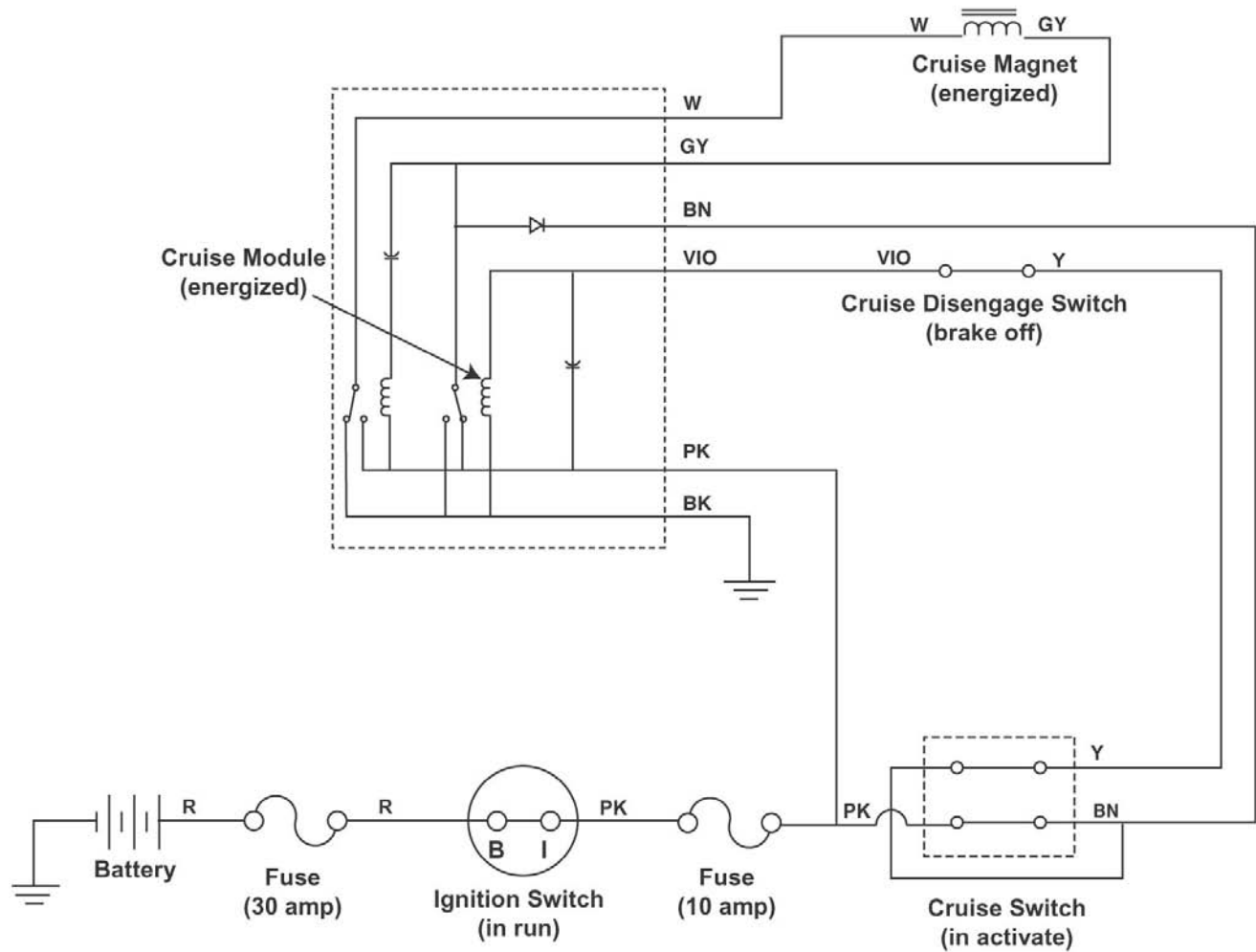

Legend	
Black	Bk
Blue	Bu
Brown	Bn
Green	Gn
Grey	Gy
Orange	Or
Pink	Pk
Red	Re
Tan	T
Violet	Vio
White	W
Yellow	Y

**Circuits**

**Cruise Control Circuit**  
(cruise "on"/ignition switch "run")

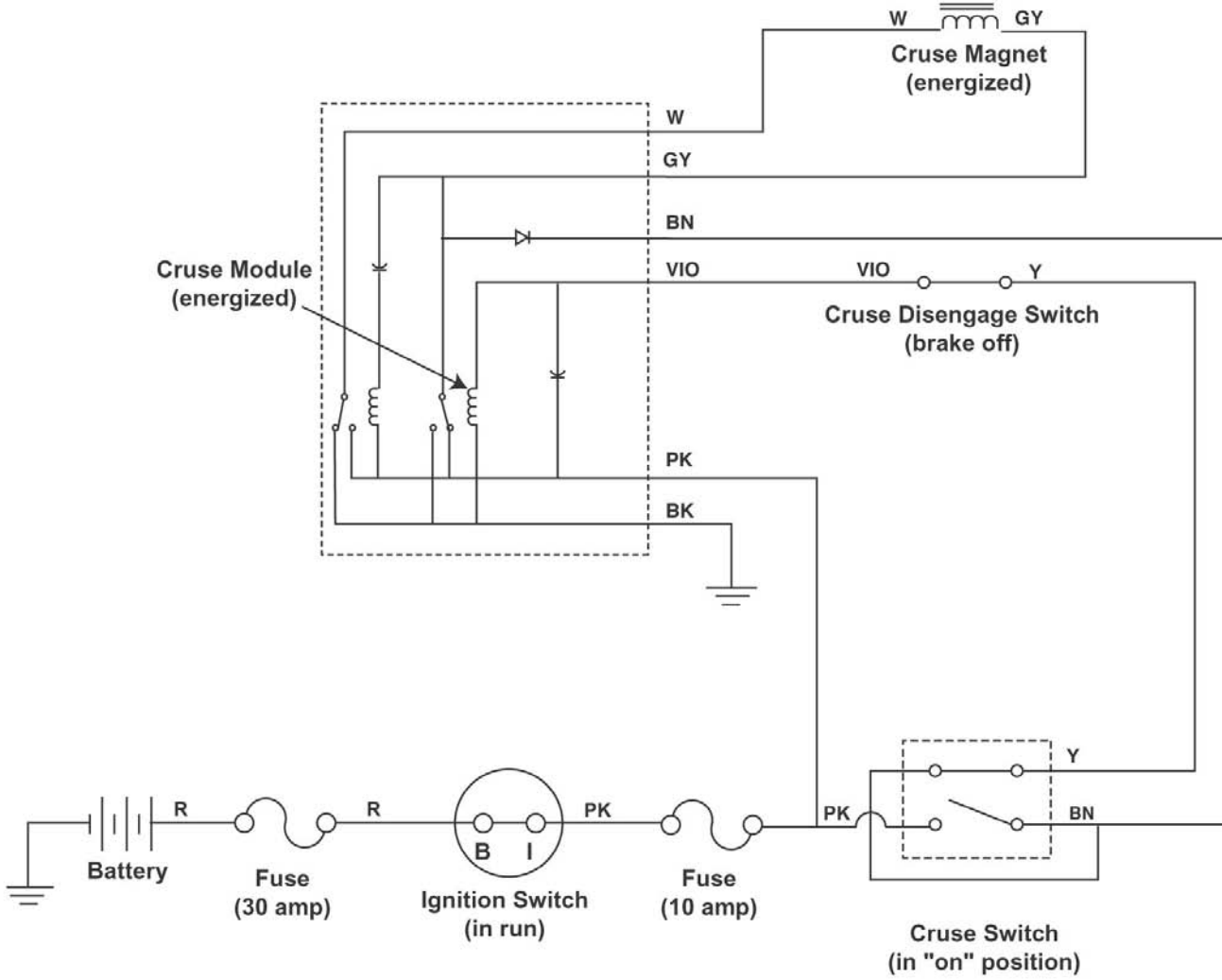

Legend	
Black	Bk
Blue	Bu
Brown	Bn
Green	Gn
Grey	Gy
Orange	Or
Pink	Pk
Red	Re
Tan	T
Violet	Vio
White	W
Yellow	Y

**Cruise Control Circuit**  
(cruise "deactivated"/ignition switch in "run")

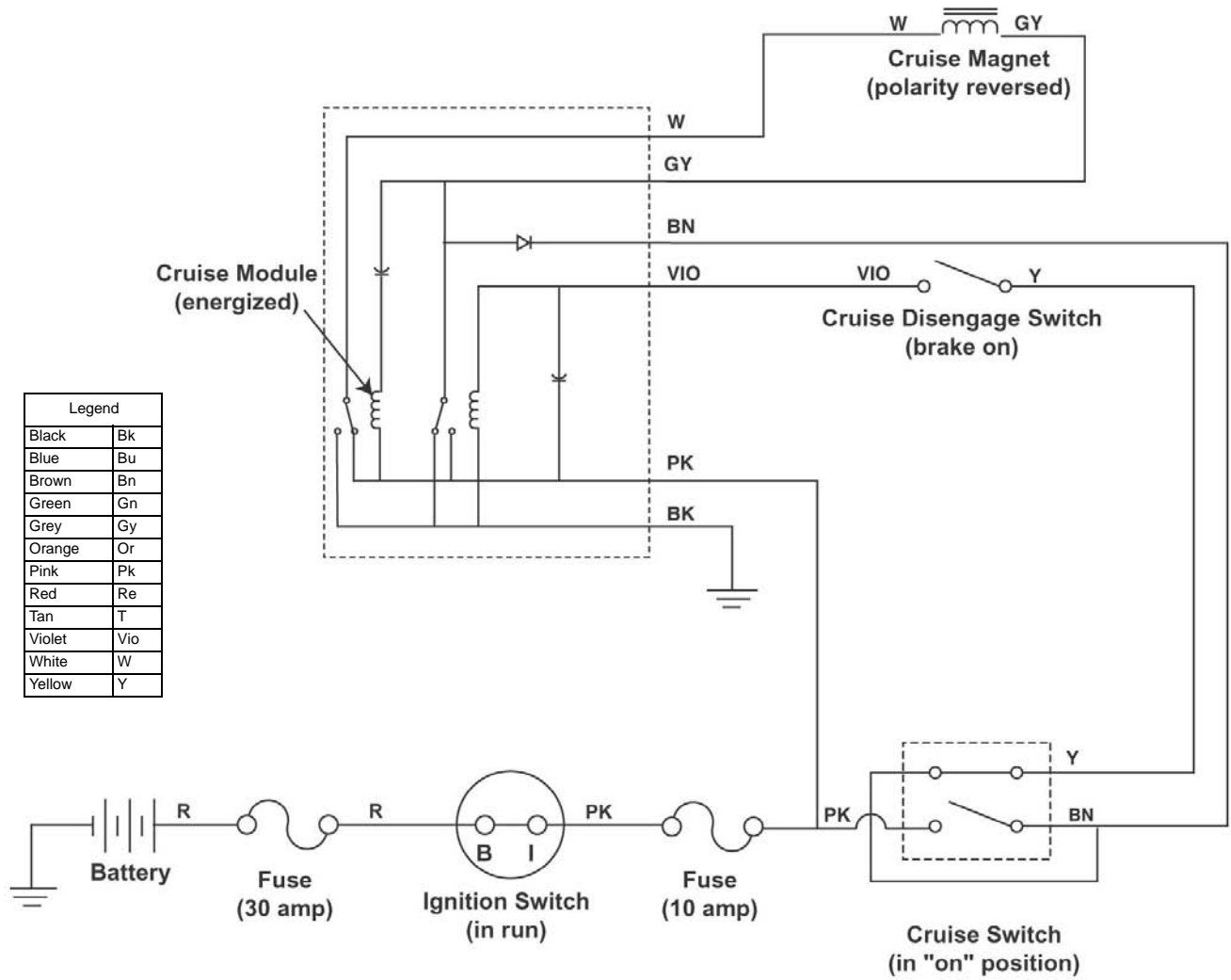

**Park Light Circuit**  
(ignition switch in "run")

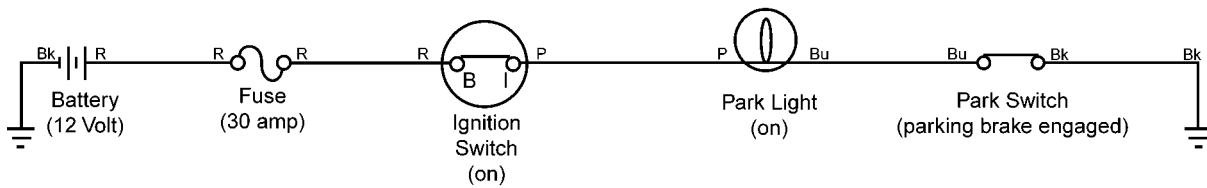

**Circuits**

**This page intentionally left blank**

**2002**  
**2003**

**Z16-44**  
**16-44ZX**



**Z16-44 Information List (2002)**  
**16-44ZX Information List (2003)**

Wiring Diagram . . . . . 15-2

Circuit Diagrams

- Starter Motor Circuit . . . . . 15-3
- Spark Circuits . . . . . 15-3 & 15-4
- Battery Charge Circuit . . . . . 15-4
- PTO Clutch Circuit . . . . . 15-4

**Wiring Diagram**

**Wiring Diagram**

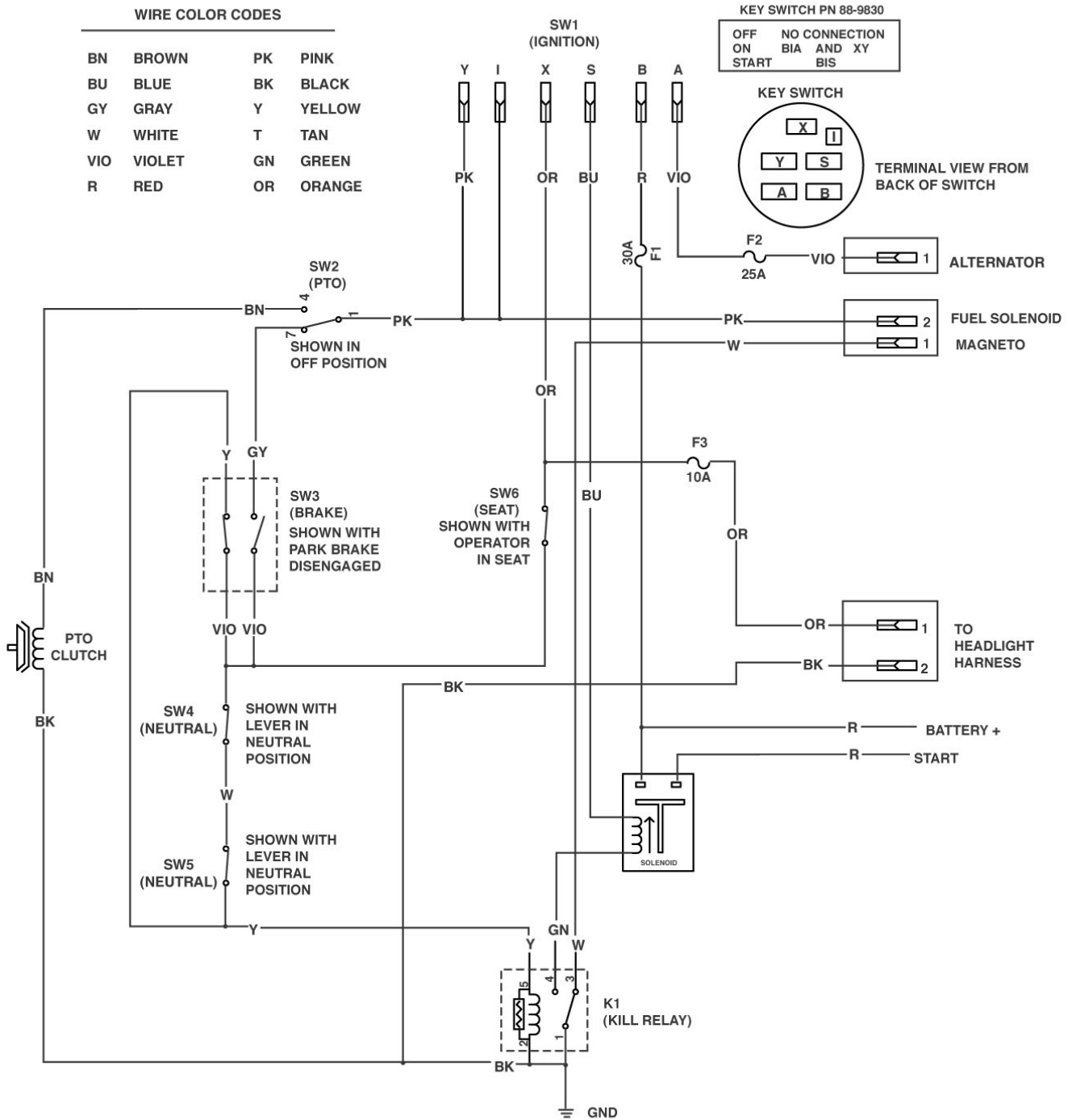



**Starter Motor Circuit**  
(ignition switch in "start")

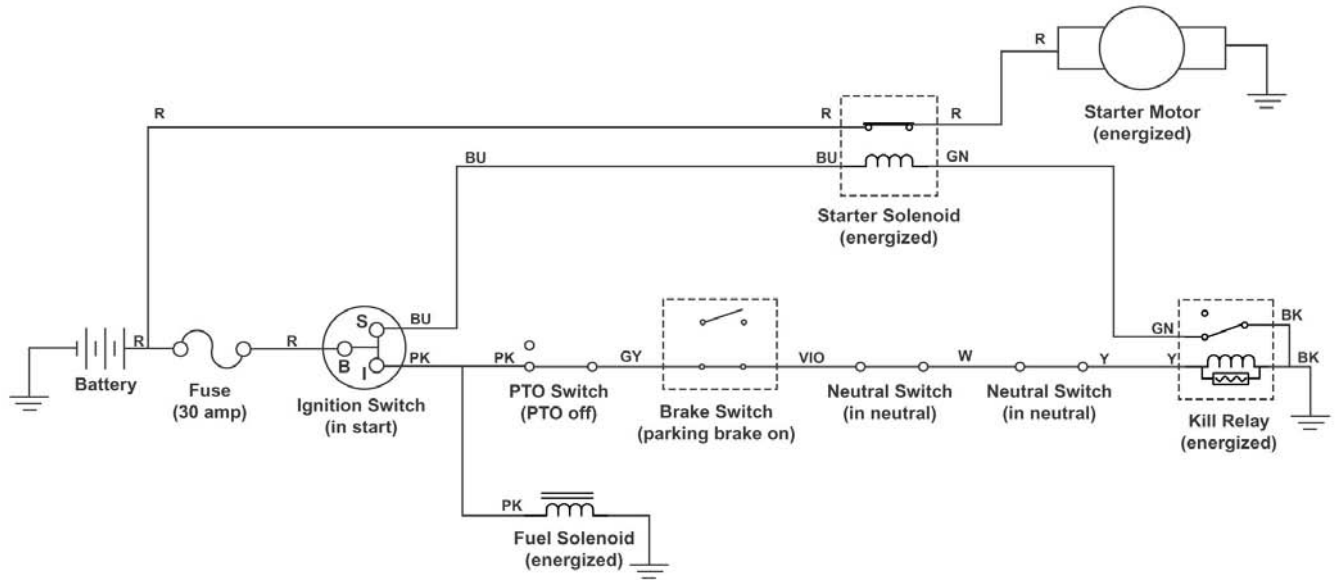

**Spark Circuit**  
(ignition switch in "start")

Legend	
Black	Bk
Blue	Bu
Brown	Bn
Green	Gn
Grey	Gy
Orange	Or
Pink	Pk
Red	Re
Tan	T
Violet	Vio
White	W
Yellow	Y

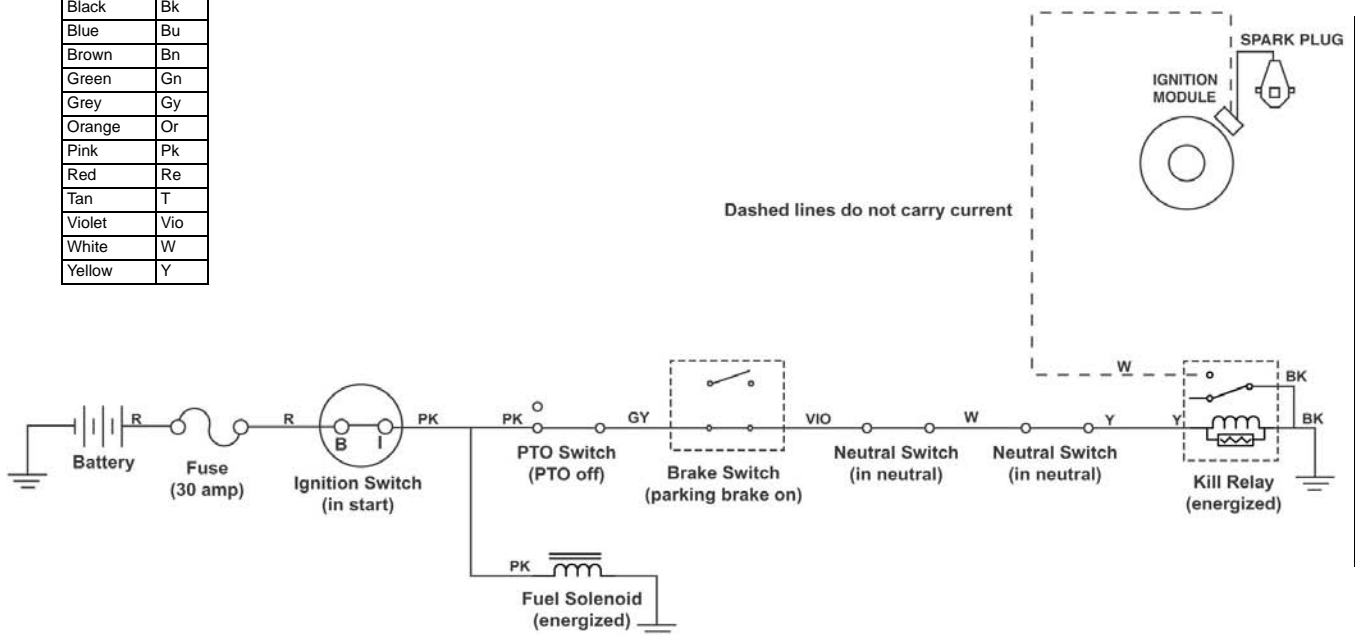

**Circuits**

**Spark Circuit**  
(ignition switch in "run")

Legend	
Black	Bk
Blue	Bu
Brown	Bn
Green	Gn
Grey	Gy
Orange	Or
Pink	Pk
Red	Re
Tan	T
Violet	Vio
White	W
Yellow	Y

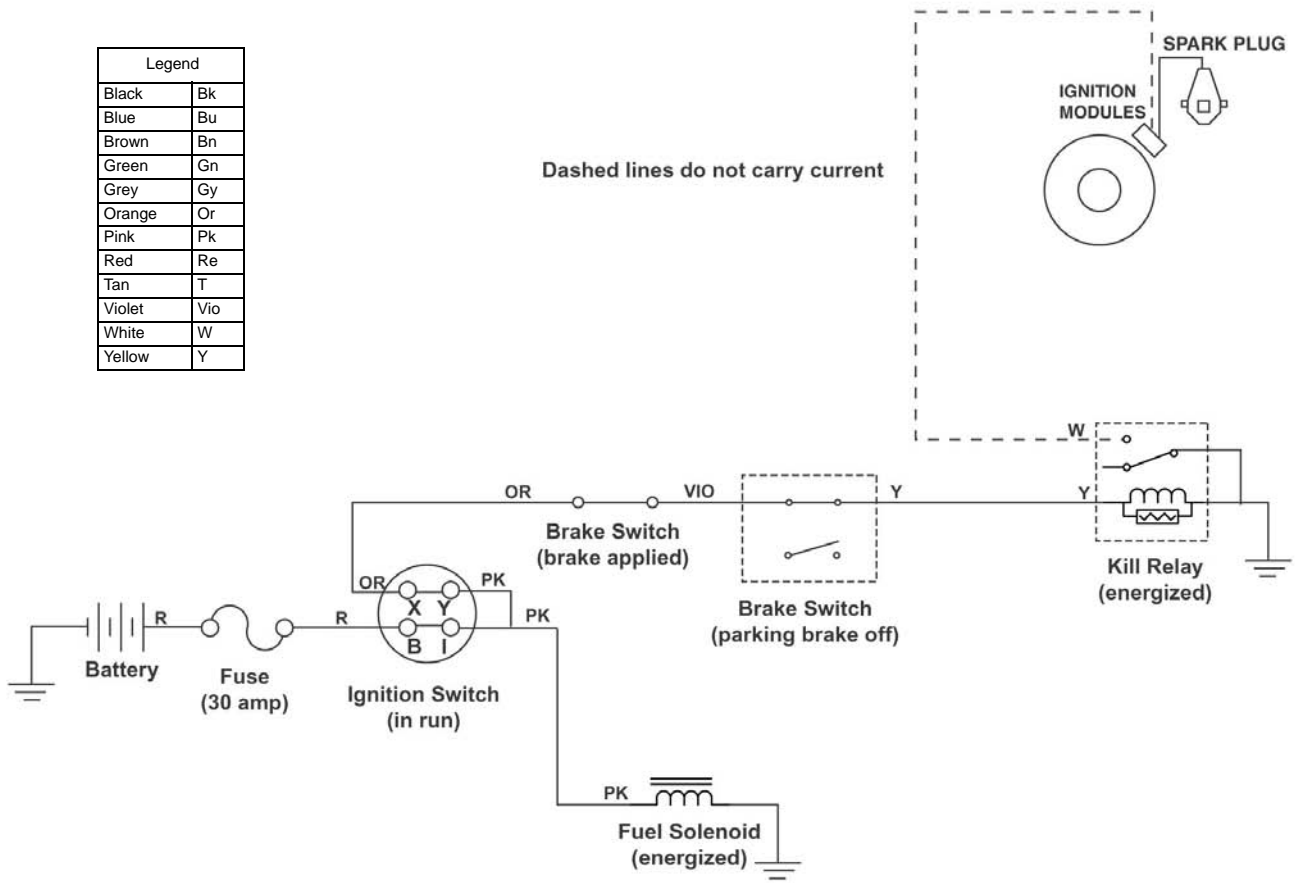

**Battery Charge Circuit**  
(ignition switch in "run")

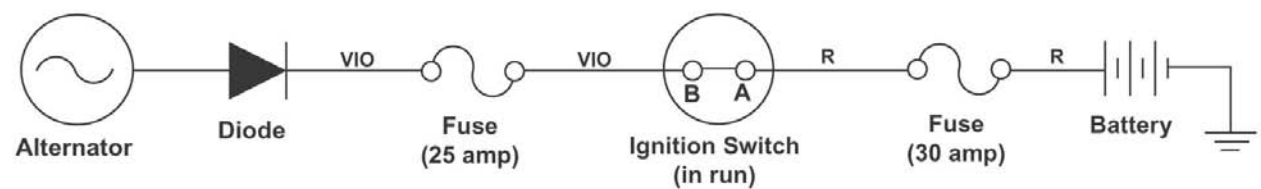

**PTO Clutch Circuit**  
(ignition switch in "run")

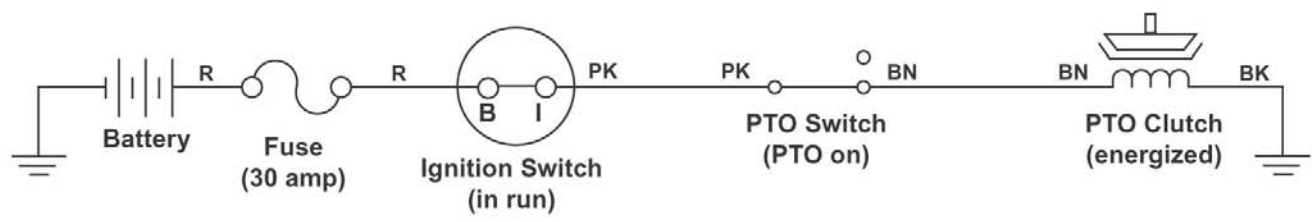

**Circuits**



**Z17-44 Information List (2002)**  
**Z17-52 Information List (2002)**  
**17K-44ZX Information List (2003)**  
**17-52ZX Information List (2003)**

Wiring Diagram . . . . . 16-2

Circuit Diagrams

- Starter Motor Circuit . . . . . 16-3
- Spark Circuits . . . . . 16-3 & 16-4
- PTO Clutch Circuit . . . . . 16-4
- Charging Circuit . . . . . 16-5
- Headlight Circuit . . . . . 16-5

Z17-44  
 Z17-52  
 17K-44ZX  
 17-52ZX

2002  
 2002  
 2003  
 2003

**Wiring Diagram**

**Wiring Diagram**

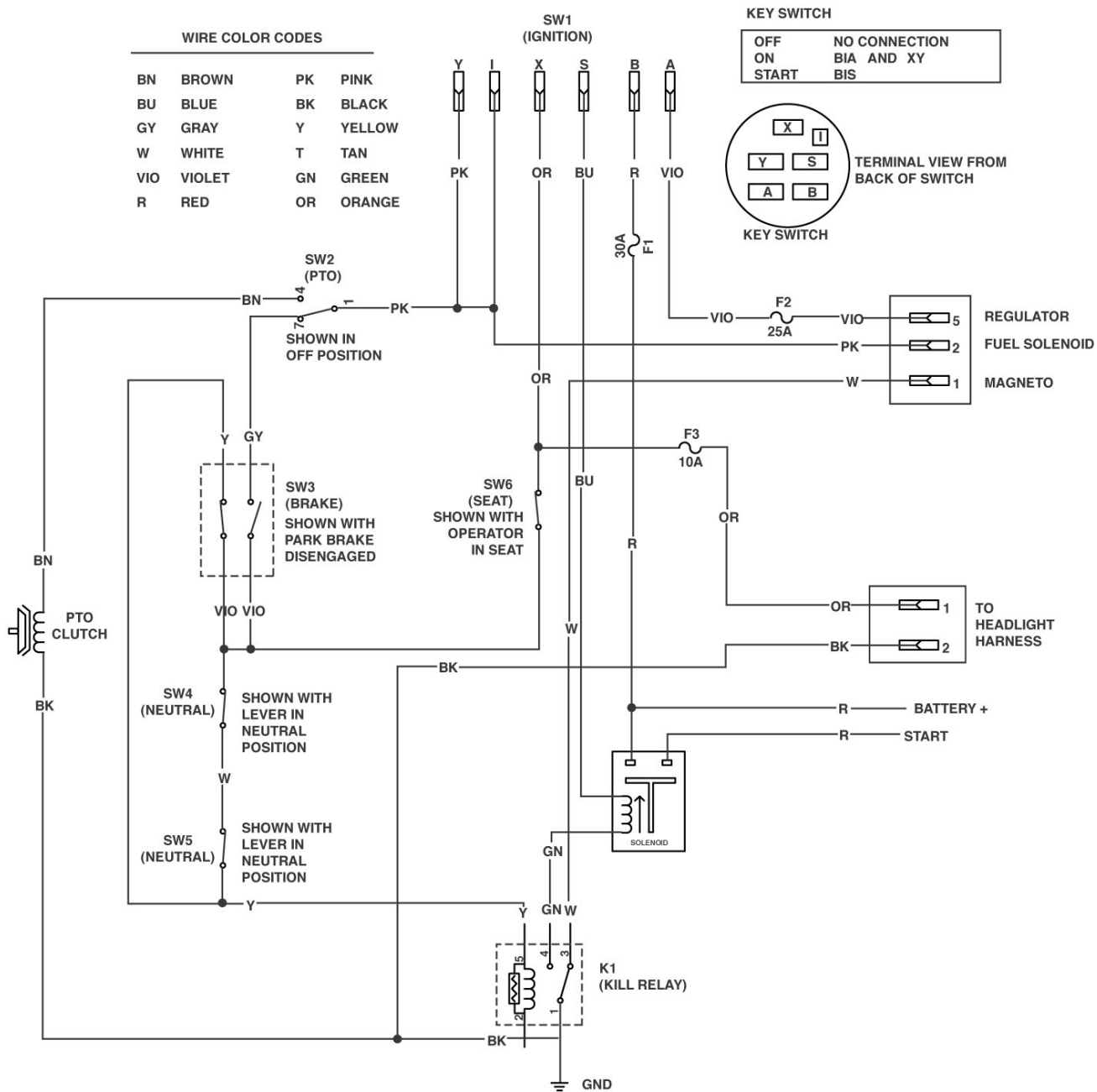

2002  
2002  
2003  
2003

Z17-44  
Z17-52  
17K-44ZX  
17-52ZX

### Starter Motor Circuit (ignition switch in "start")

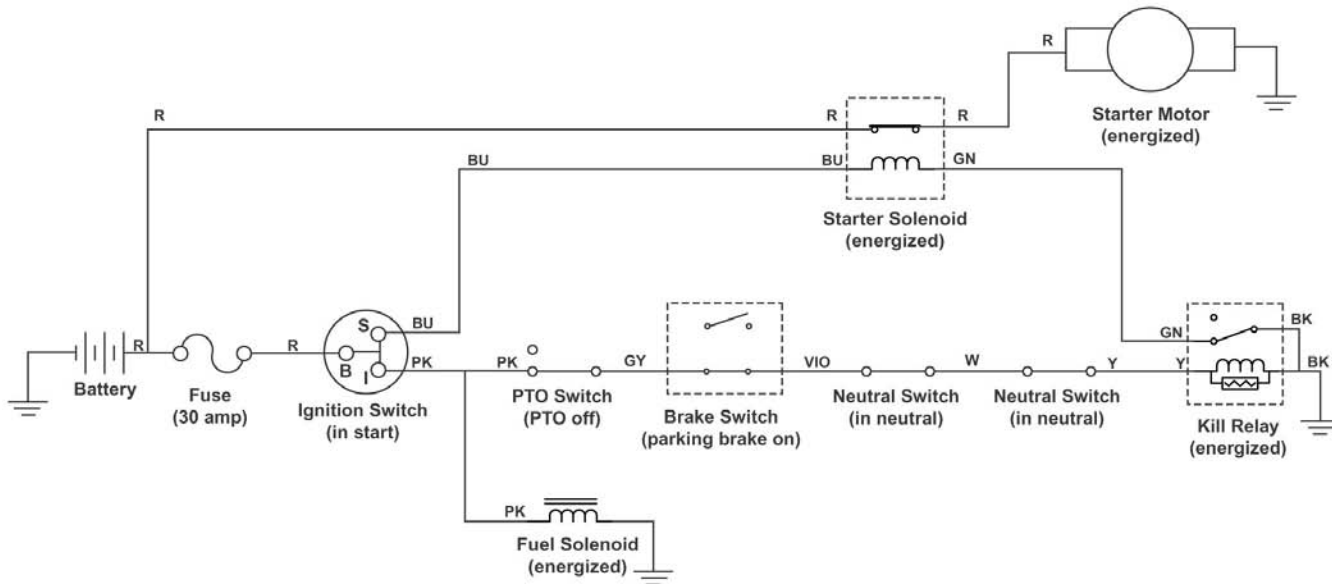

### Spark Circuit (ignition switch in "start")

Legend	
Black	Bk
Blue	Bu
Brown	Bn
Green	Gn
Grey	Gy
Orange	Or
Pink	Pk
Red	Re
Tan	T
Violet	Vio
White	W
Yellow	Y

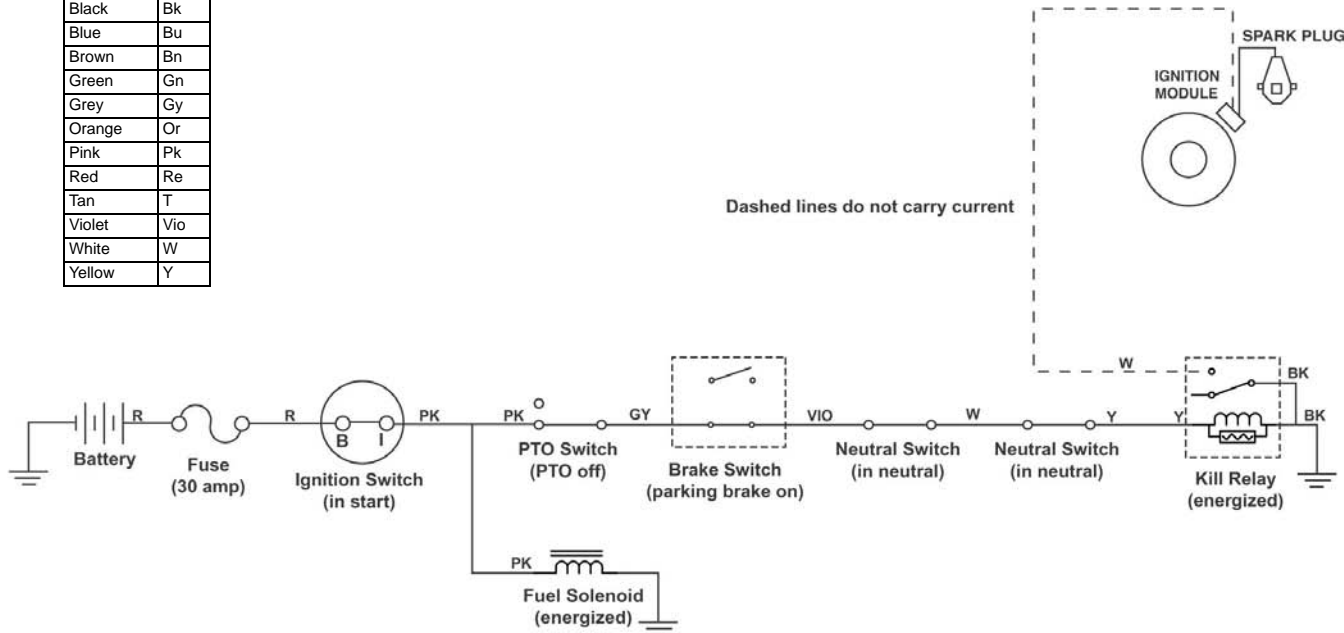

**Circuits**

**Z17-44**  
**Z17-52**  
**17K-44ZX**  
**17-52ZX**

**2002**  
**2002**  
**2003**  
**2003**

**Spark Circuit**  
*(ignition switch in "run")*

Legend	
Black	Bk
Blue	Bu
Brown	Bn
Green	Gn
Grey	Gy
Orange	Or
Pink	Pk
Red	Re
Tan	T
Violet	Vio
White	W
Yellow	Y

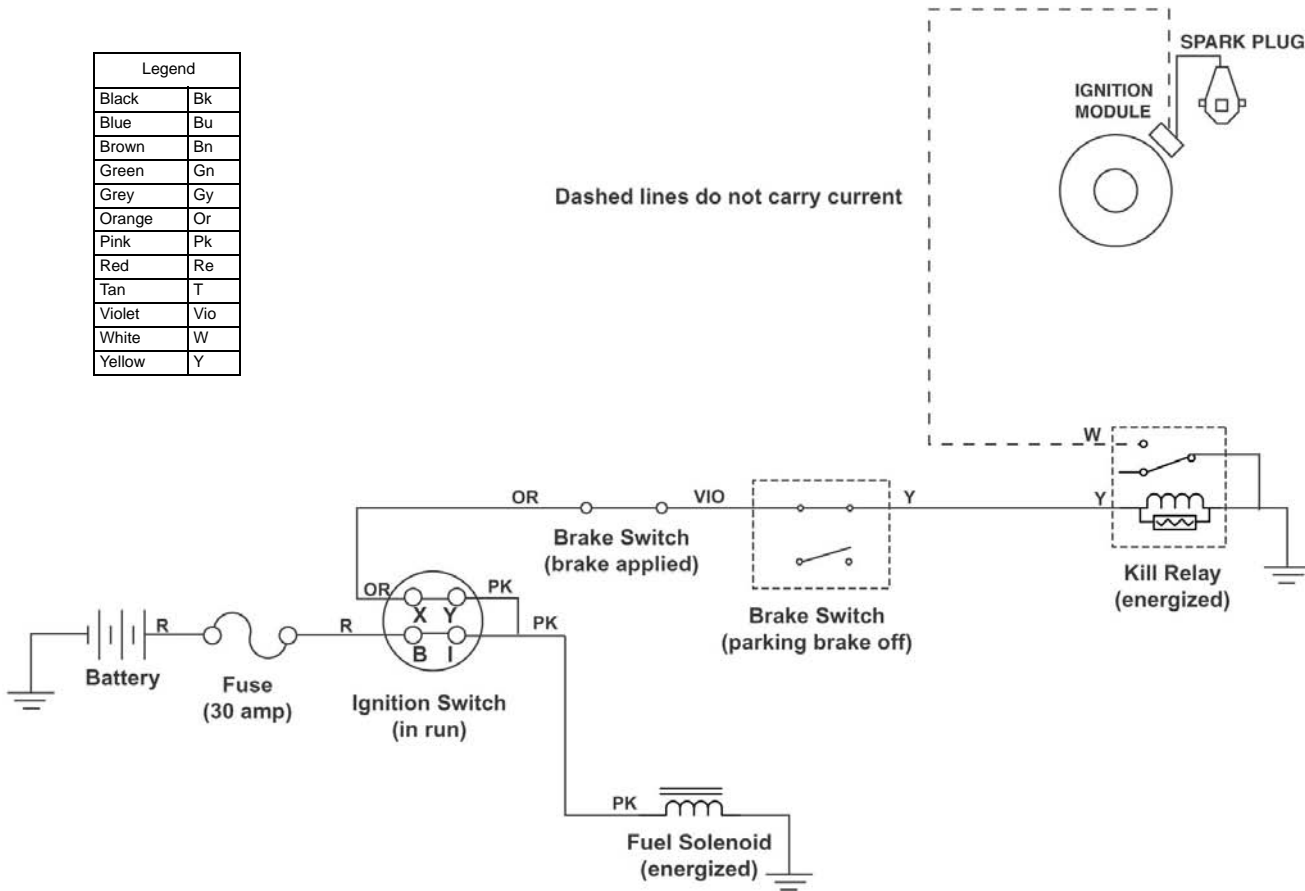

**PTO Clutch Circuit**  
*(ignition switch in "run")*

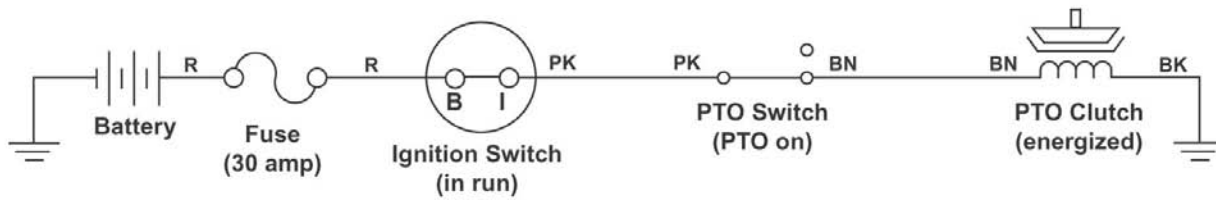

**Circuits**

2002  
2002  
2003  
2003

Z17-44  
Z17-52  
17K-44ZX  
17-52ZX

**Charging Circuit**  
(ignition switch in "run")

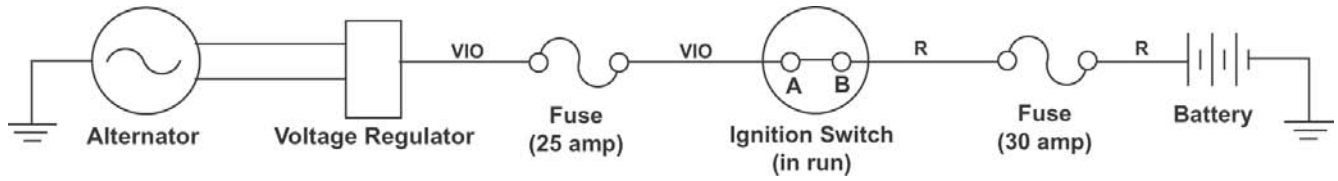

Legend	
Black	Bk
Blue	Bu
Brown	Bn
Green	Gn
Grey	Gy
Orange	Or
Pink	Pk
Red	Re
Tan	T
Violet	Vio
White	W
Yellow	Y

**This page intentionally left blank**





**Z18-52 Information List (2002)  
18-52ZX Information List (2003)**

Wiring Diagram . . . . . 17-2  
Circuit Diagrams  
    Starter Motor Circuit . . . . . 17-3  
    Spark Circuits . . . . . 17-3 & 17-4  
    Battery Charge Circuit . . . . . 17-4  
    PTO Clutch Circuit . . . . . 17-4

**Wiring Diagram**

218-52 2002

**Wiring Diagram**

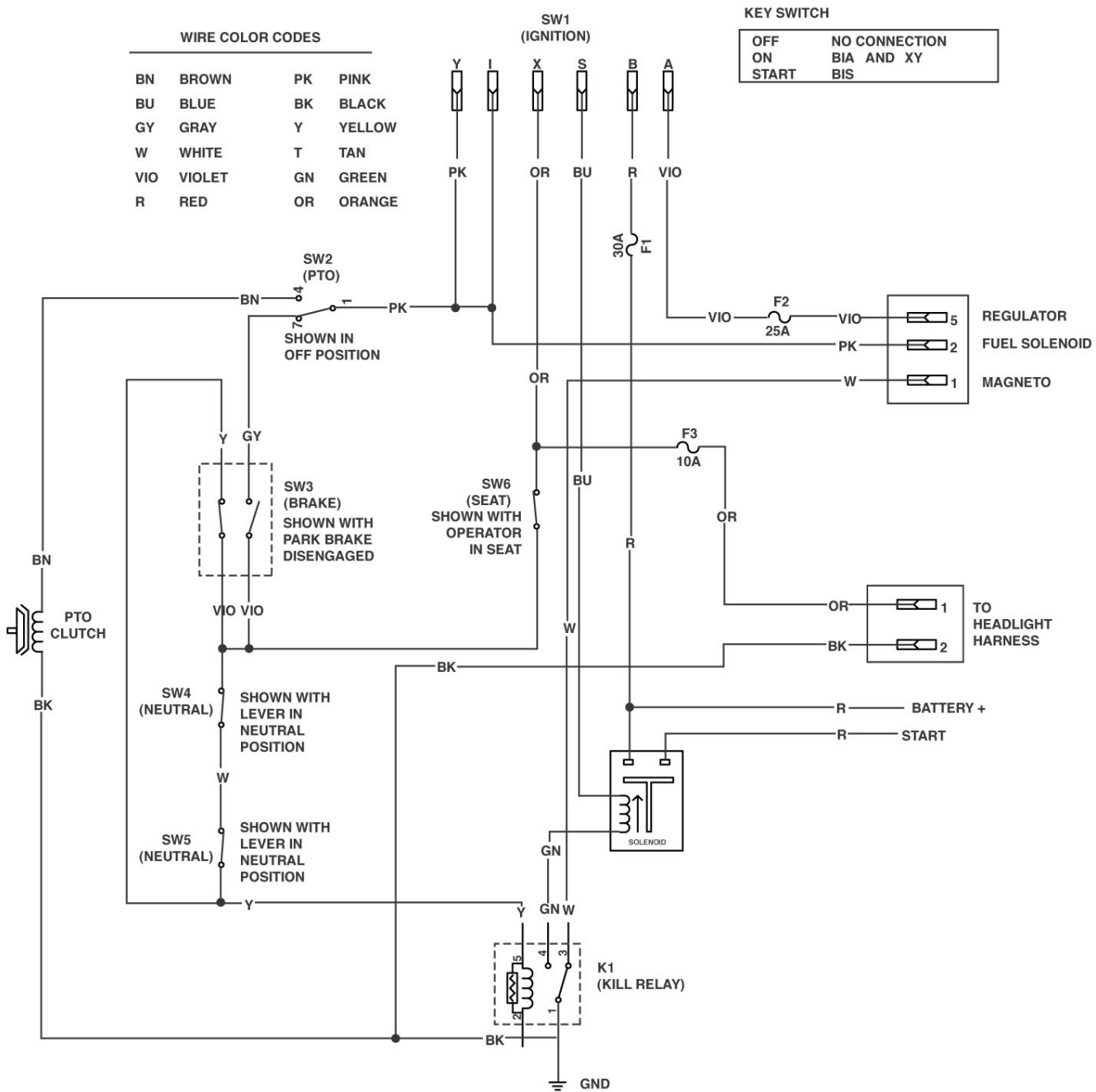

**Starter Motor Circuit**  
(ignition switch in "start")

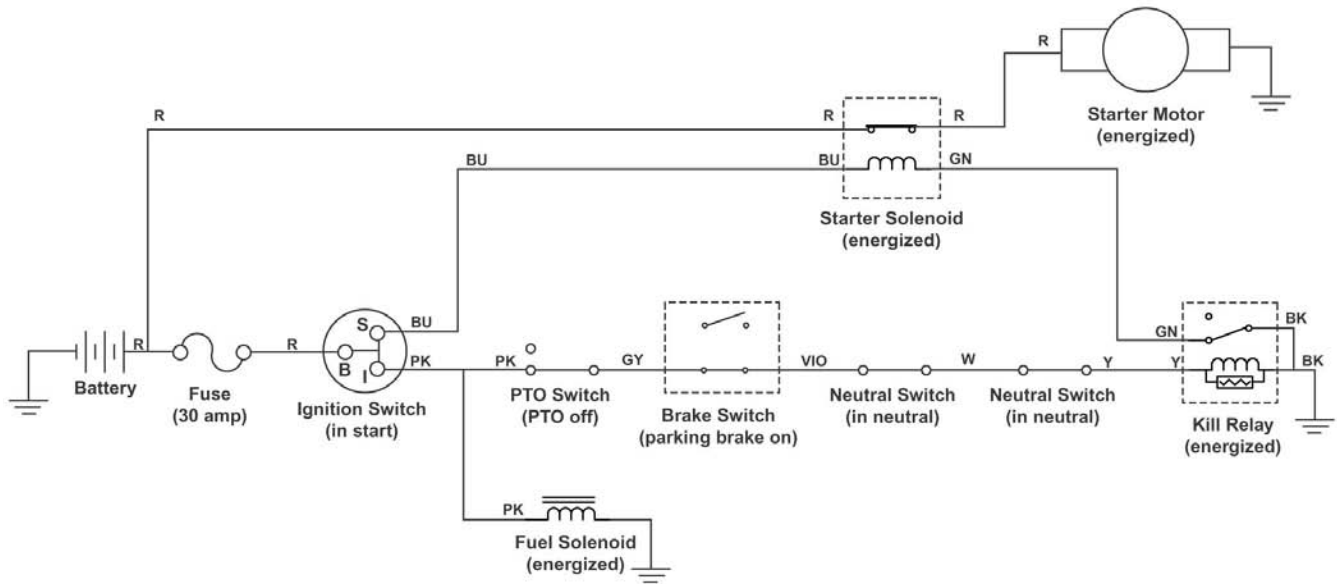

**Spark Circuit**  
(ignition switch in "start")

Legend	
Black	Bk
Blue	Bu
Brown	Bn
Green	Gn
Grey	Gy
Orange	Or
Pink	Pk
Red	Re
Tan	T
Violet	Vio
White	W
Yellow	Y

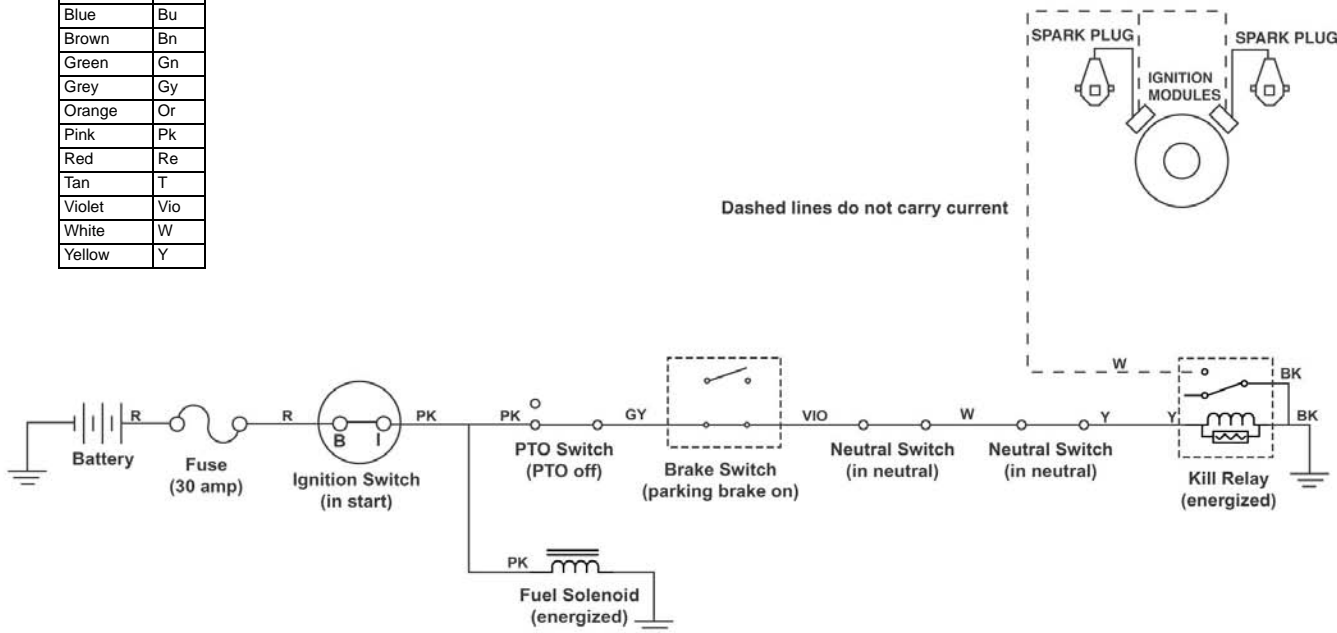

**Circuits**

**Spark Circuit**  
*(ignition switch in "run")*

Legend	
Black	Bk
Blue	Bu
Brown	Bn
Green	Gn
Grey	Gy
Orange	Or
Pink	Pk
Red	Re
Tan	T
Violet	Vio
White	W
Yellow	Y

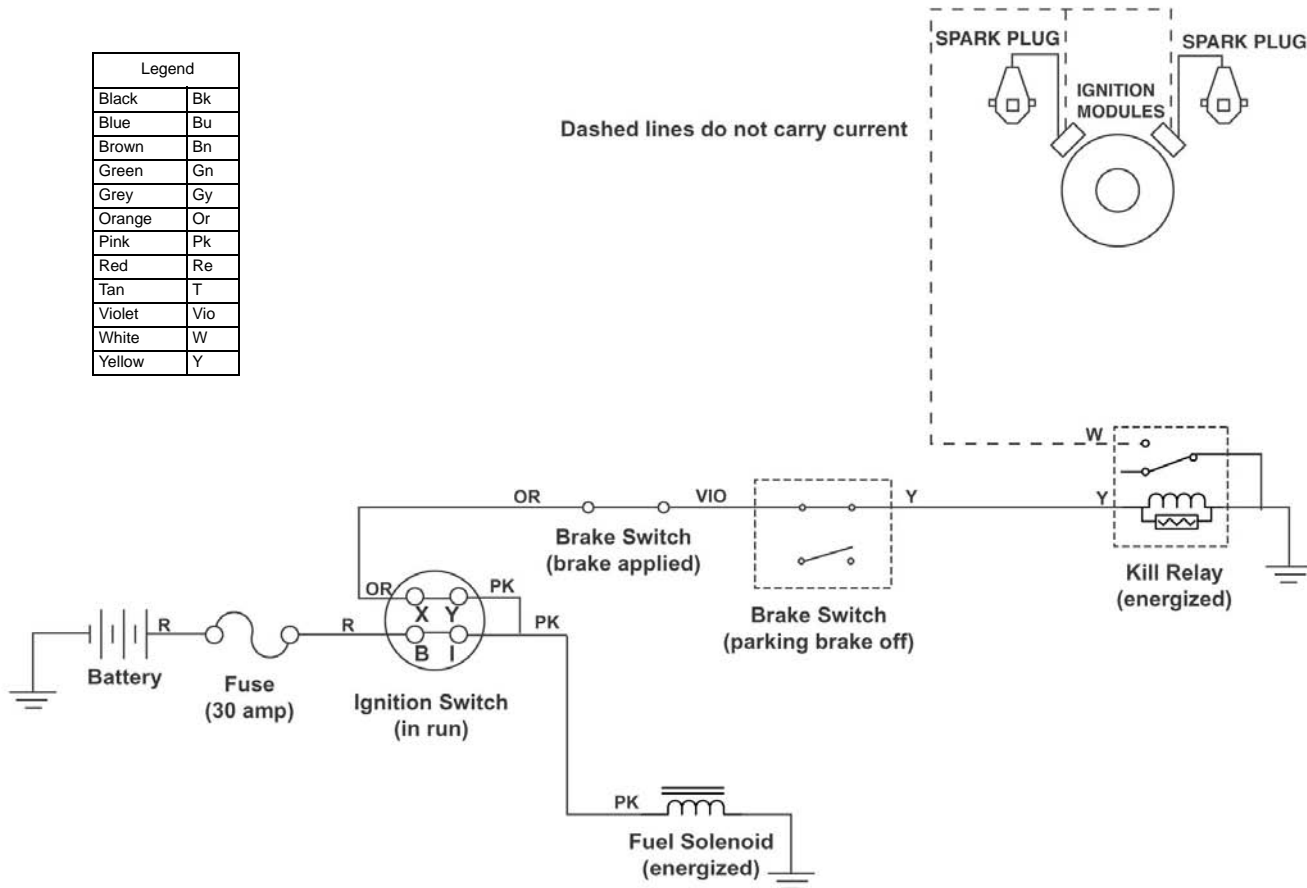

**Circuits**

**Battery Charge Circuit**  
*(ignition switch in "run")*

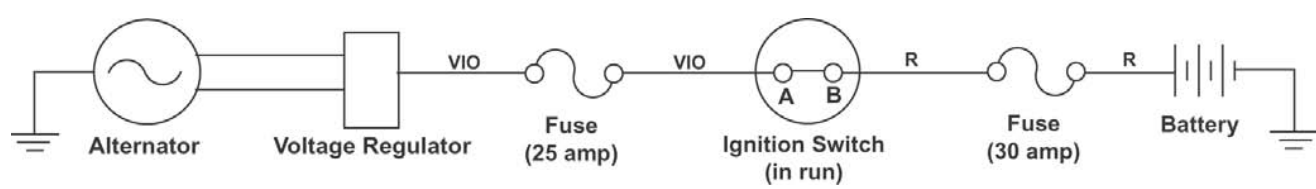

**PTO Clutch Circuit**  
*(ignition switch in "run")*

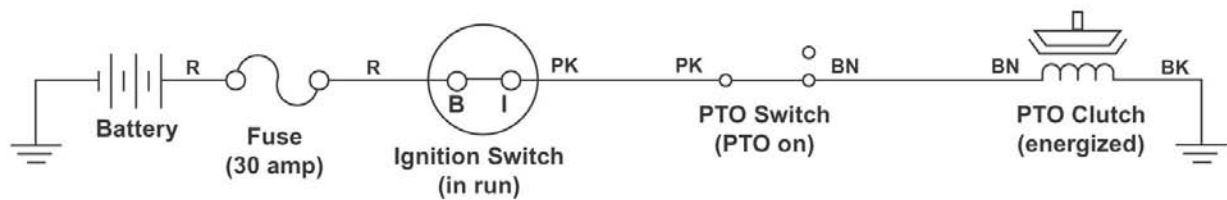

**2003**  
**2003**

**14-38Z**  
**16-42Z**



**14-38Z Information List (2003)**  
**16-42Z Information List (2003)**

Wiring Diagram . . . . . 18-2  
Circuit Diagrams  
    Starter Motor Circuit . . . . . 18-3  
    Spark Circuits . . . . . 18-3 & 18-4  
    Battery Charge Circuit . . . . . 18-4  
    PTO Clutch Circuit . . . . . 18-4



**Starter Motor Circuit**  
(ignition switch in "start")

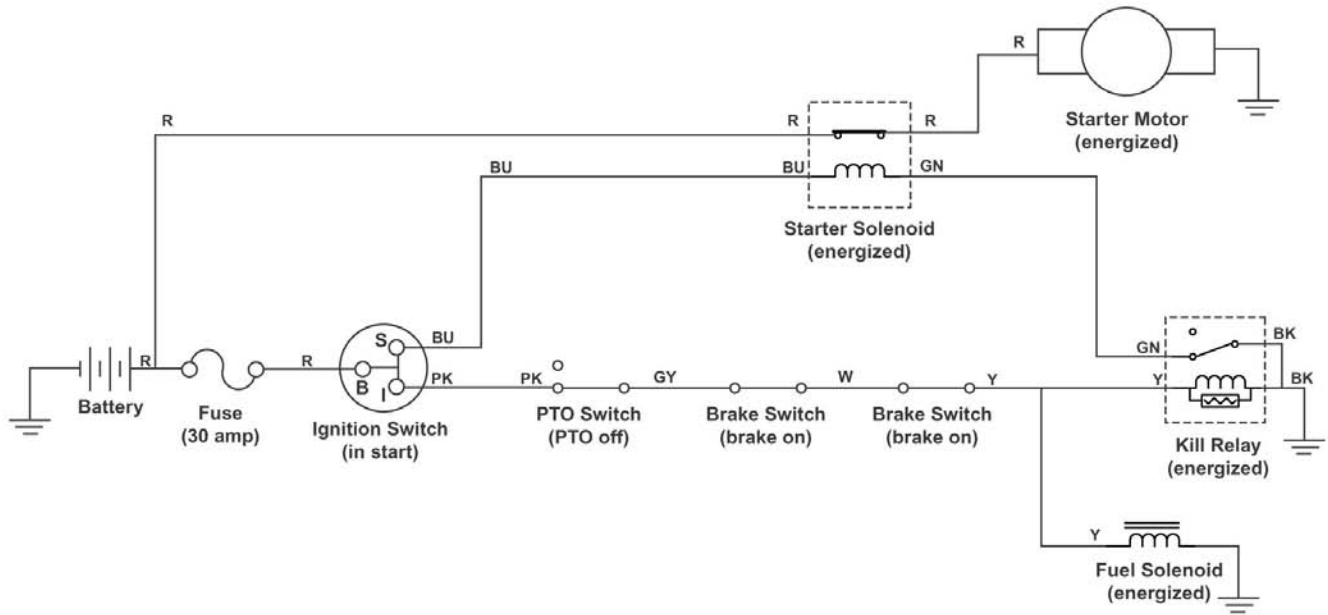

**Spark Circuit**  
(ignition switch in "start")

Legend	
Black	Bk
Blue	Bu
Brown	Bn
Green	Gn
Grey	Gy
Orange	Or
Pink	Pk
Red	Re
Tan	T
Violet	Vio
White	W
Yellow	Y

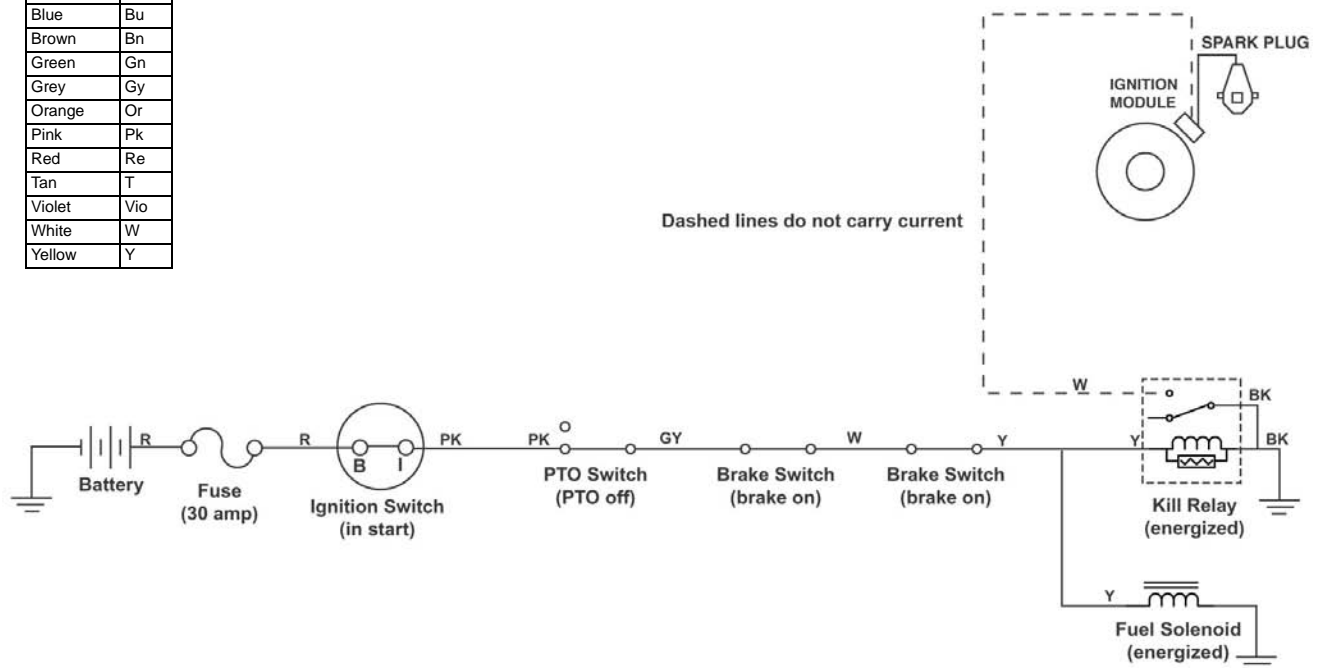

**Circuits**

**Spark Circuit**  
(ignition switch in "run")

Legend	
Black	Bk
Blue	Bu
Brown	Bn
Green	Gn
Grey	Gy
Orange	Or
Pink	Pk
Red	Re
Tan	T
Violet	Vio
White	W
Yellow	Y

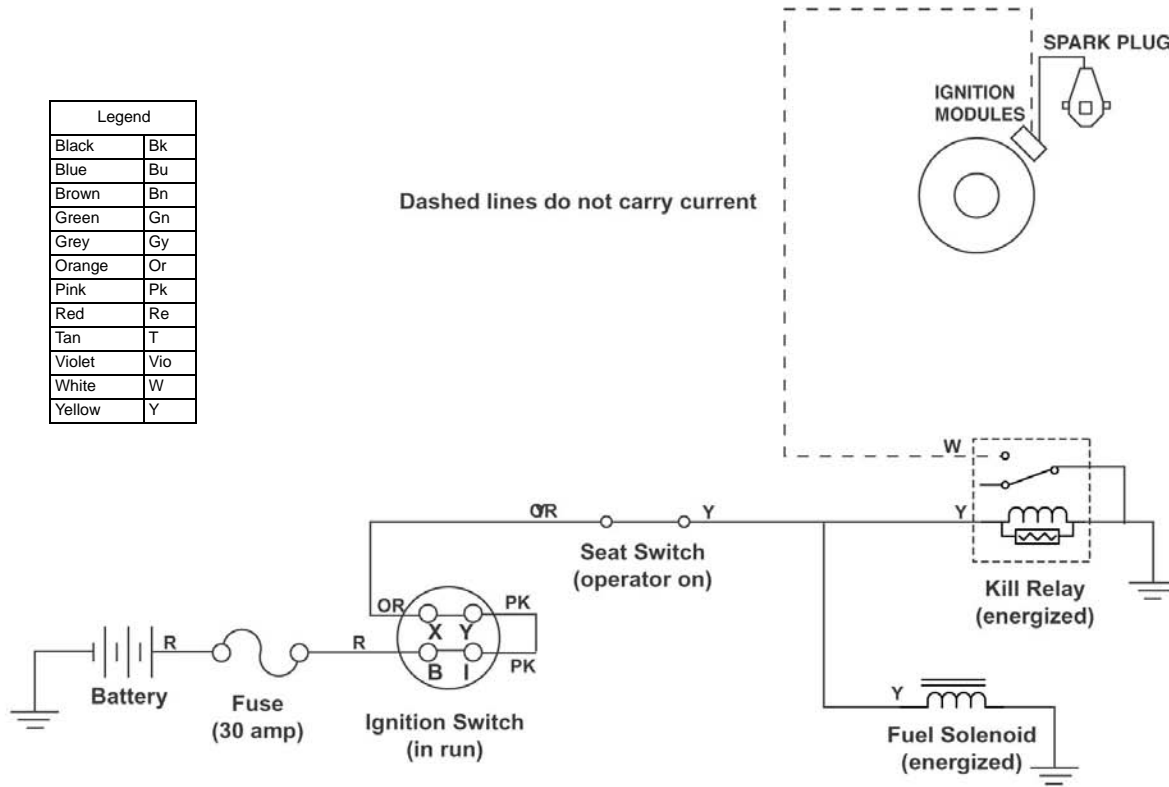

**Battery Charge Circuit**  
(ignition switch in "run")

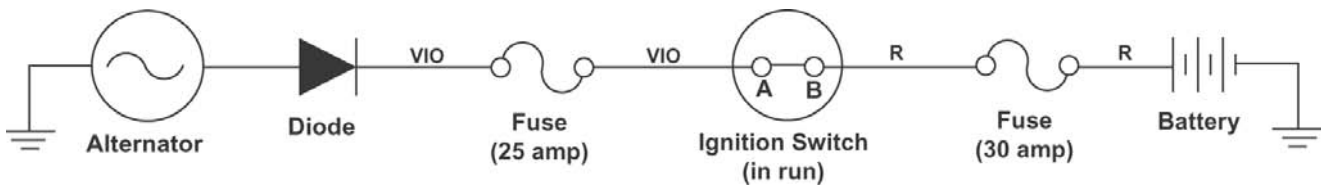

**PTO Clutch Circuit**  
(ignition switch in "run")

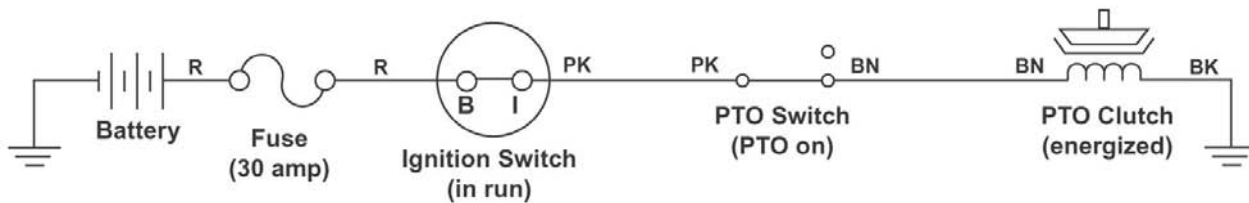





**17-42Z Information List (2003)**

Wiring Diagram ..... 19-2

Circuit Diagrams

    Starter Motor Circuit ..... 19-3

    Spark Circuits ..... 19-3 & 19-4

    Battery Charge Circuit ..... 19-4

    PTO Clutch Circuit ..... 19-4

Wiring Diagram

Wiring Diagram

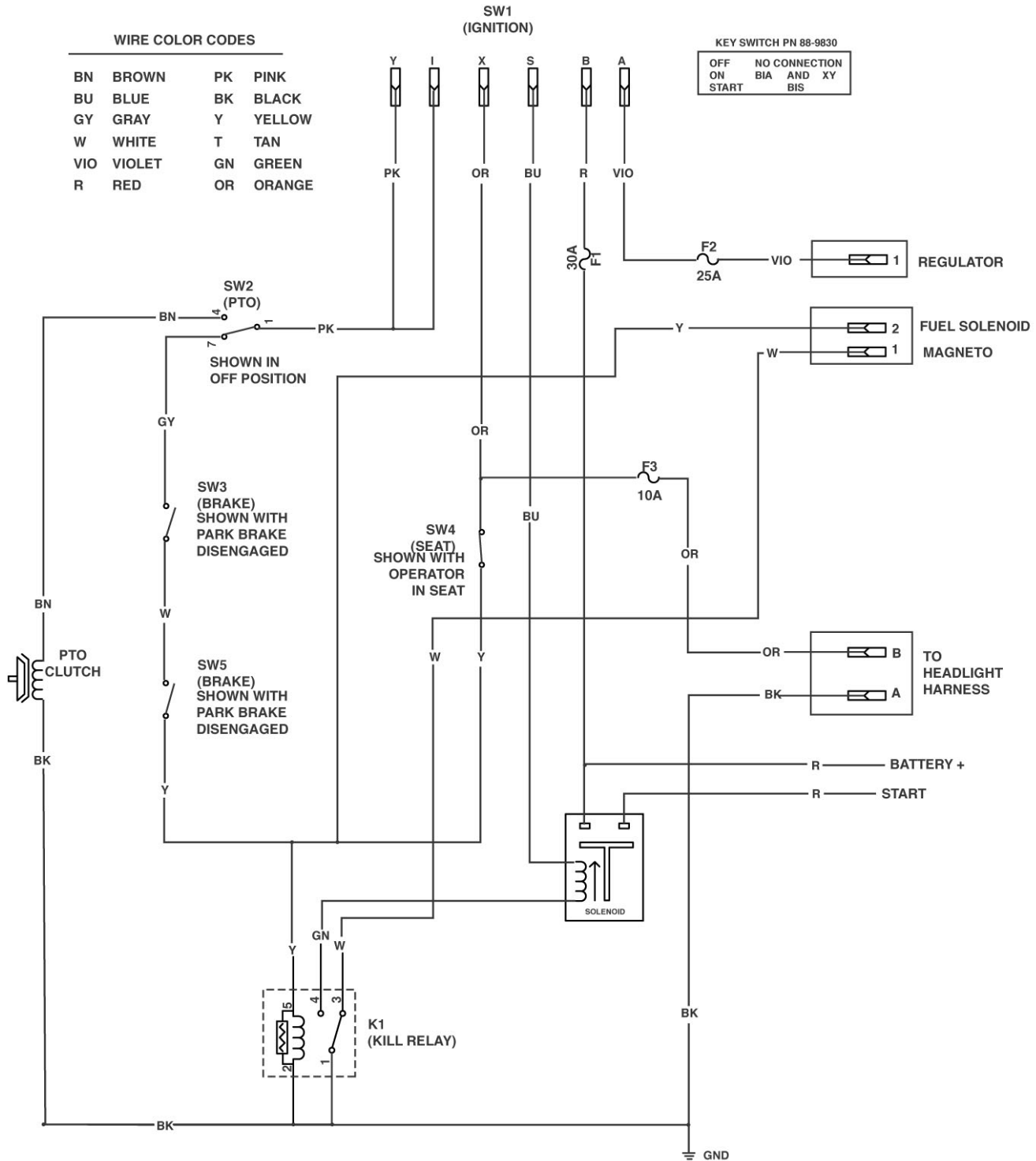

**Starter Motor Circuit**  
(ignition switch in "start")

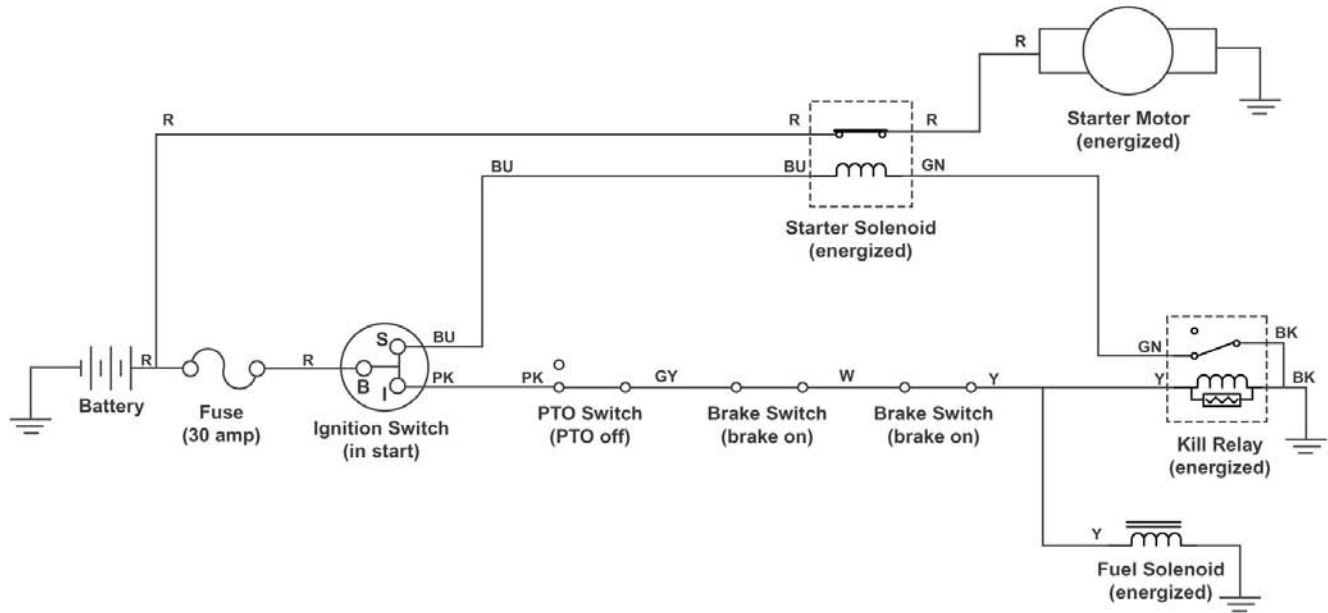

**Spark Circuit**  
(ignition switch in "start")

Legend	
Black	Bk
Blue	Bu
Brown	Bn
Green	Gn
Grey	Gy
Orange	Or
Pink	Pk
Red	Re
Tan	T
Violet	Vio
White	W
Yellow	Y

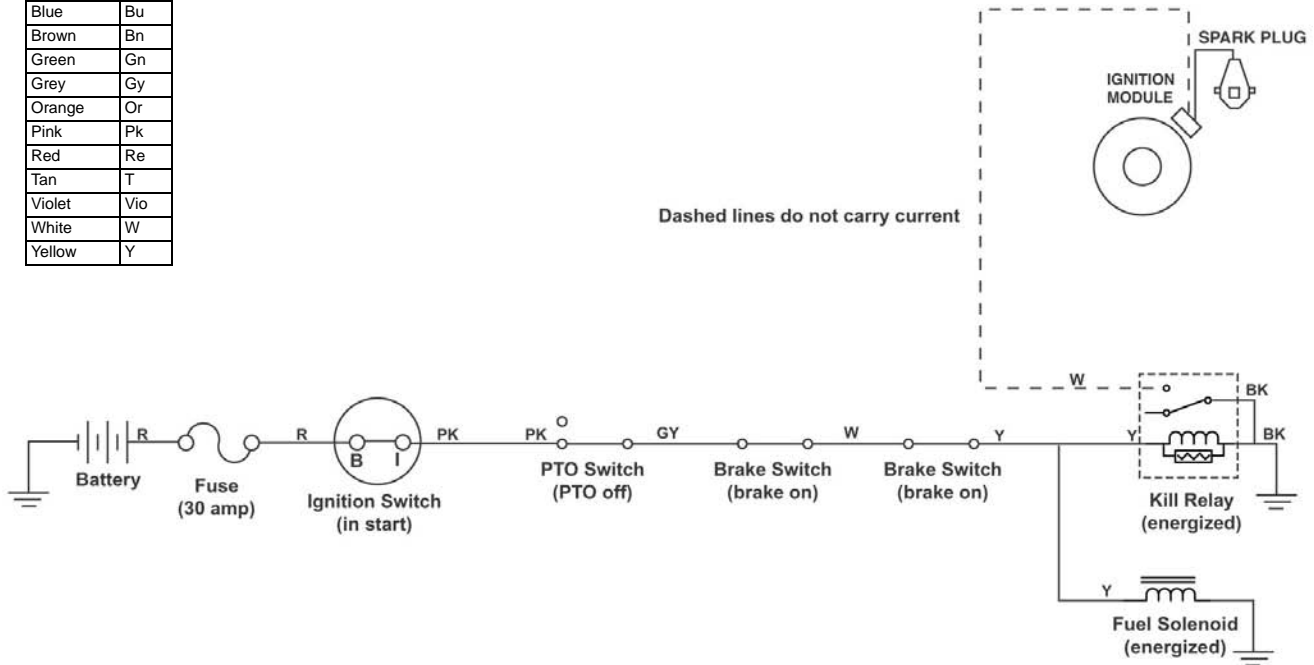

**Circuits**

**Spark Circuit**  
(ignition switch in "run")

Legend	
Black	Bk
Blue	Bu
Brown	Bn
Green	Gn
Grey	Gy
Orange	Or
Pink	Pk
Red	Re
Tan	T
Violet	Vio
White	W
Yellow	Y

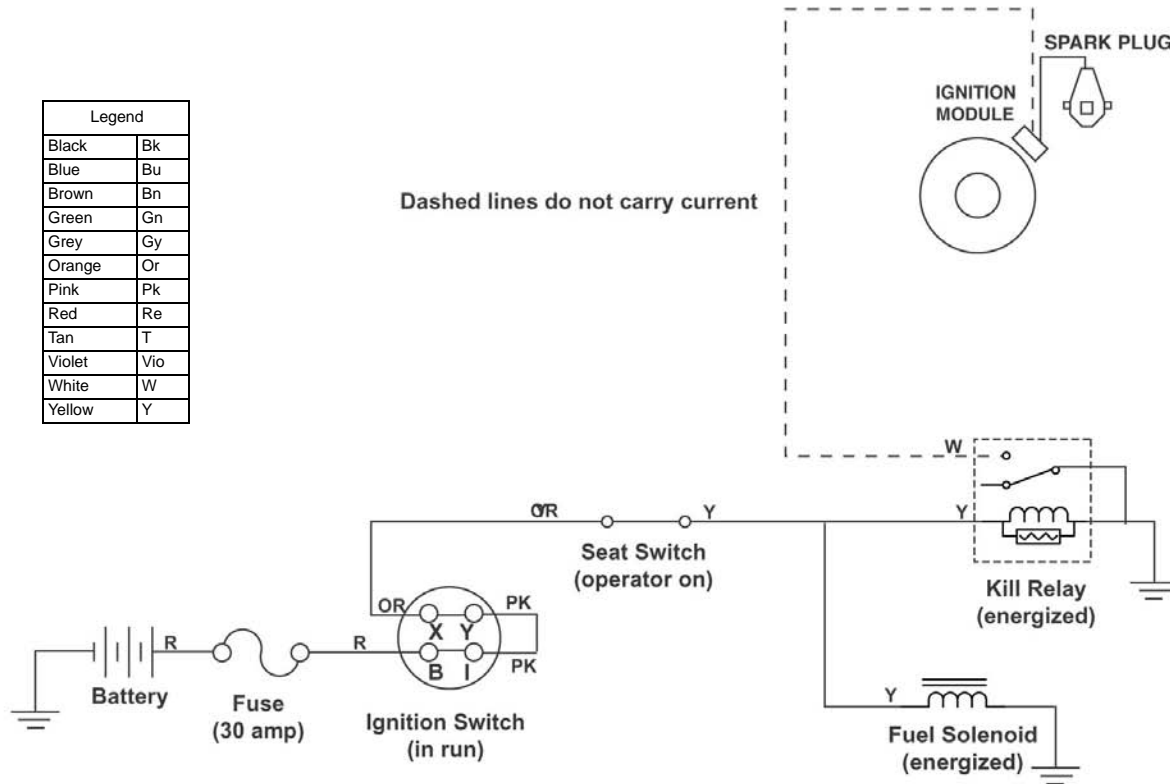

**Battery Charge Circuit**  
(ignition switch in "run")

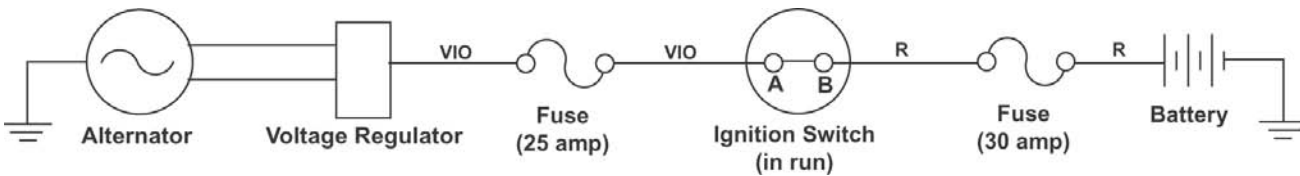

**PTO Clutch Circuit**  
(ignition switch in "run")

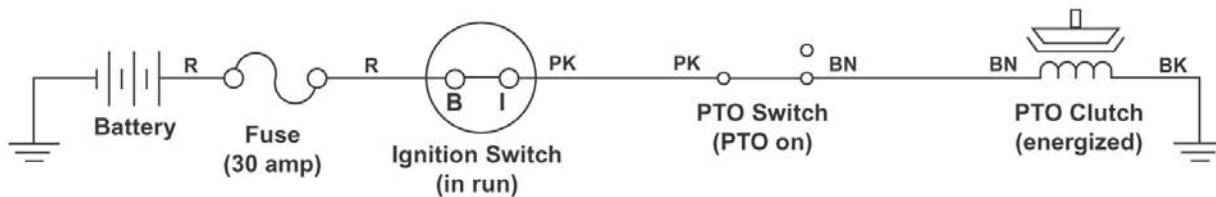

Circuits



**Twister Vehicle Information List (2002-2003)**

Wiring Diagram ..... 20-2

Circuit Diagrams

- Starter Motor Circuit ..... 20-3
- Spark Circuit ..... 20-3
- Charging Circuit ..... 20-4
- Headlight Circuit ..... 20-4
- Hourmeter Circuit ..... 20-4
- Oil Pressure Switch Circuit ..... 20-5

## Wiring Diagram

# Wiring Diagram

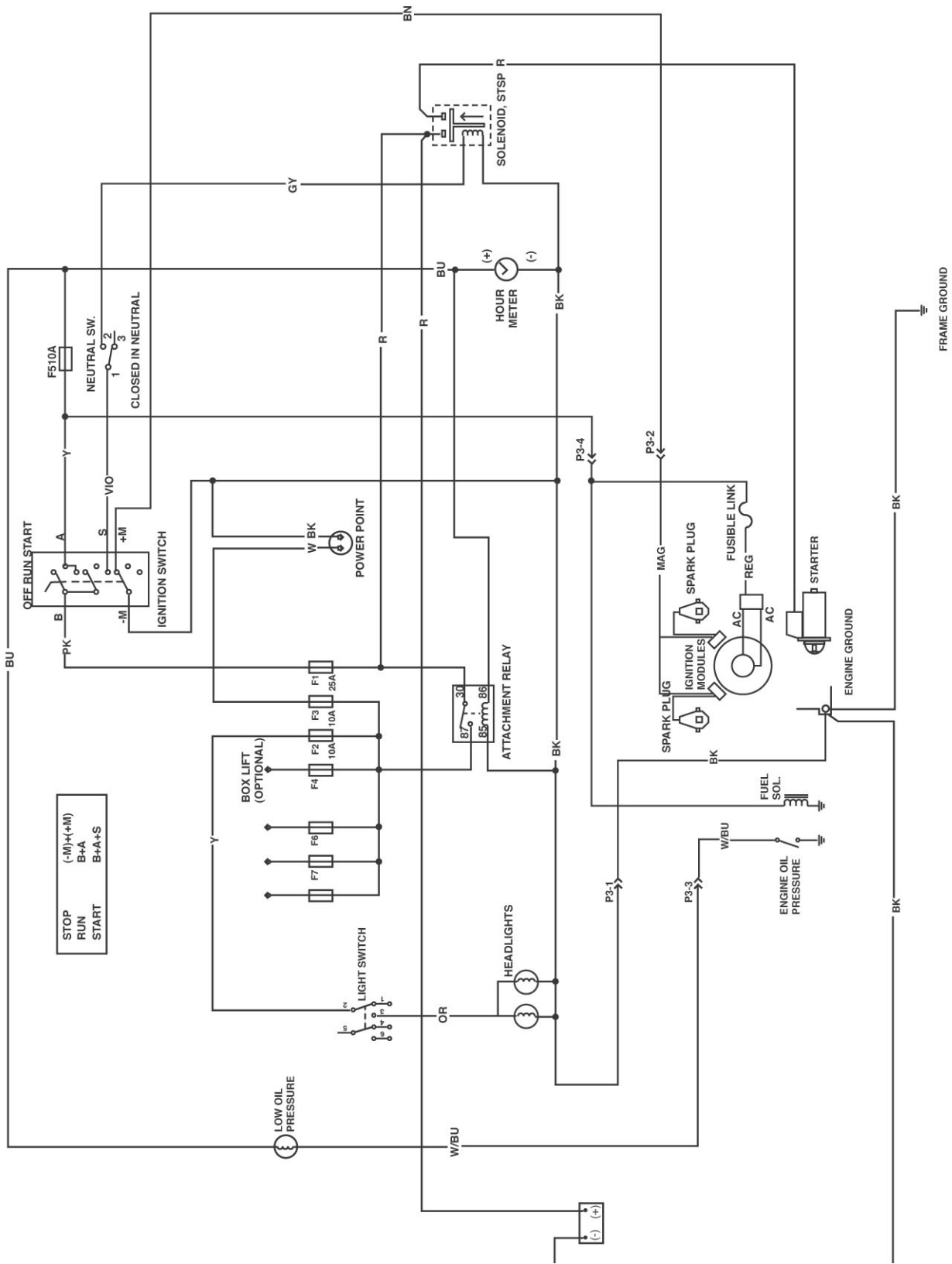

**Starter Motor Circuit**  
(ignition switch in "start")

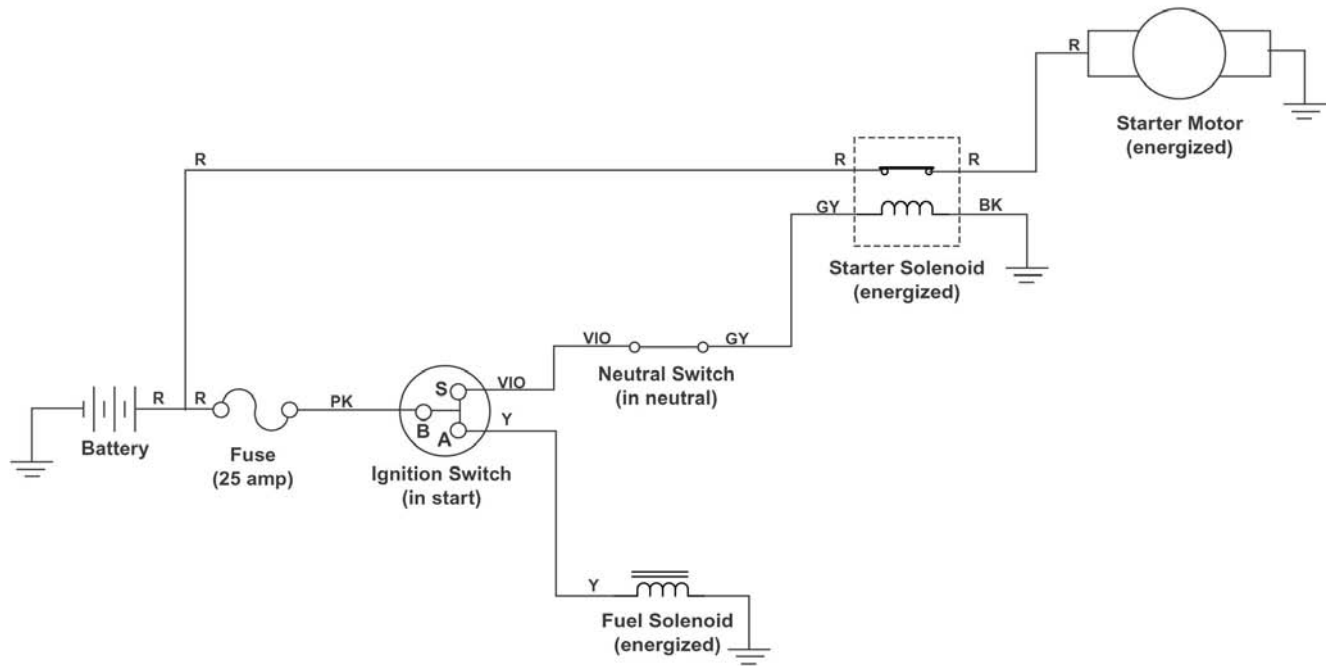

**Spark Circuit**  
(ignition switch in "start")

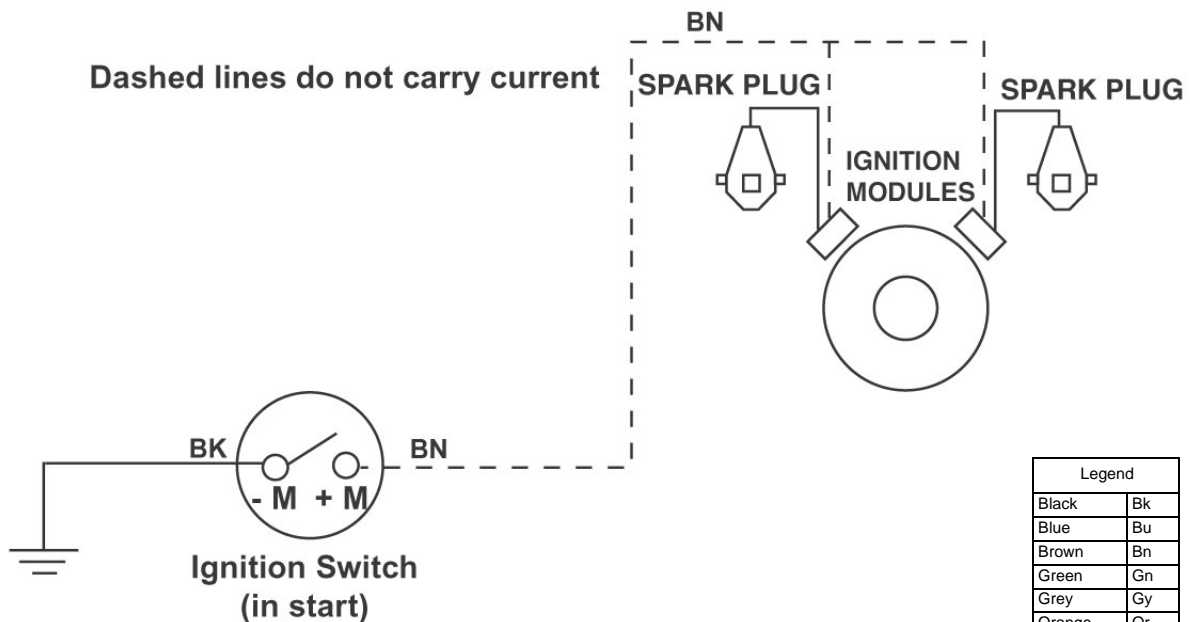

**Circuits**

## Charging Circuit

(ignition switch in "run")

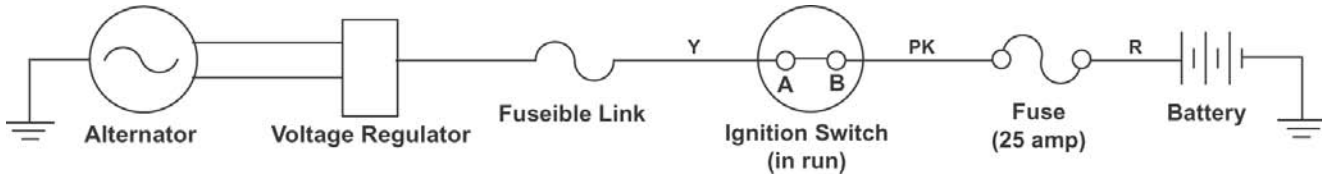

## Headlight Circuit

(ignition switch in "run/lights")

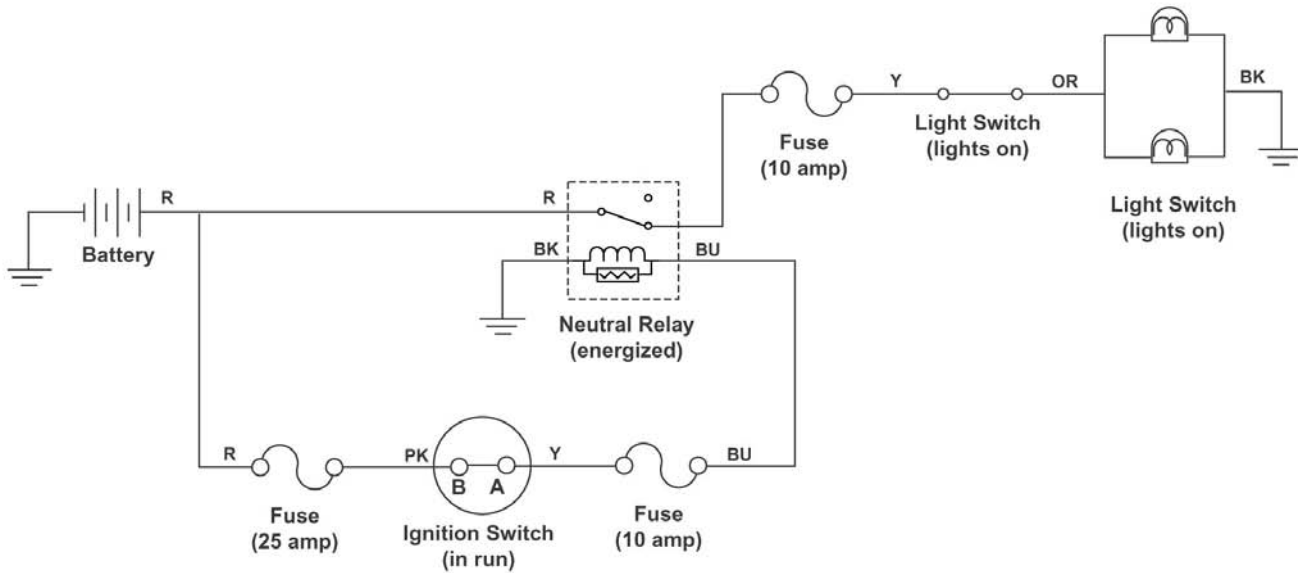

## Hourmeter Circuit

(ignition switch in "run")

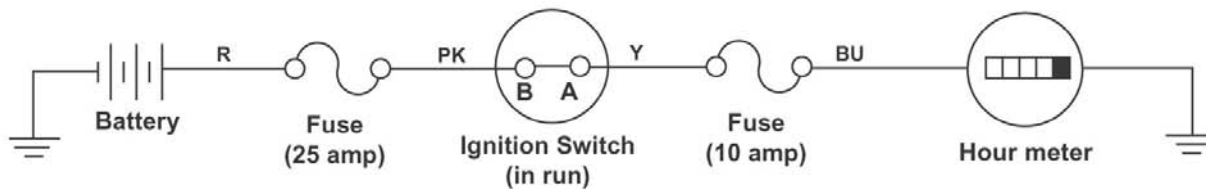

**Circuits**

Legend	
Black	Bk
Blue	Bu
Brown	Bn
Green	Gn
Grey	Gy
Orange	Or
Pink	Pk
Red	Re
Tan	T
Violet	Vio
White	W
Yellow	Y



**Oil Pressure Switch Circuit**  
(ignition switch in "run")

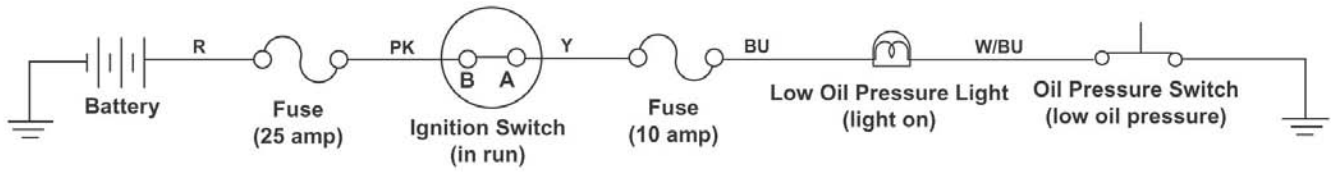

Legend	
Black	Bk
Blue	Bu
Brown	Bn
Green	Gn
Grey	Gy
Orange	Or
Pink	Pk
Red	Re
Tan	T
Violet	Vio
White	W
Yellow	Y

**This page intentionally left blank**



**1332-G International Information List (2002 - 2003)**

Wiring Diagrams . . . . . 21-2 & 21-3  
Circuit Diagrams  
    Starter Motor Circuit . . . . . 21-4  
    Spark Circuits . . . . . 21-4 - 21-7  
    Battery Charge Circuit . . . . . 21-8  
    Bag Full Circuit . . . . . 21-8

## Wiring Diagram

Wiring Diagram

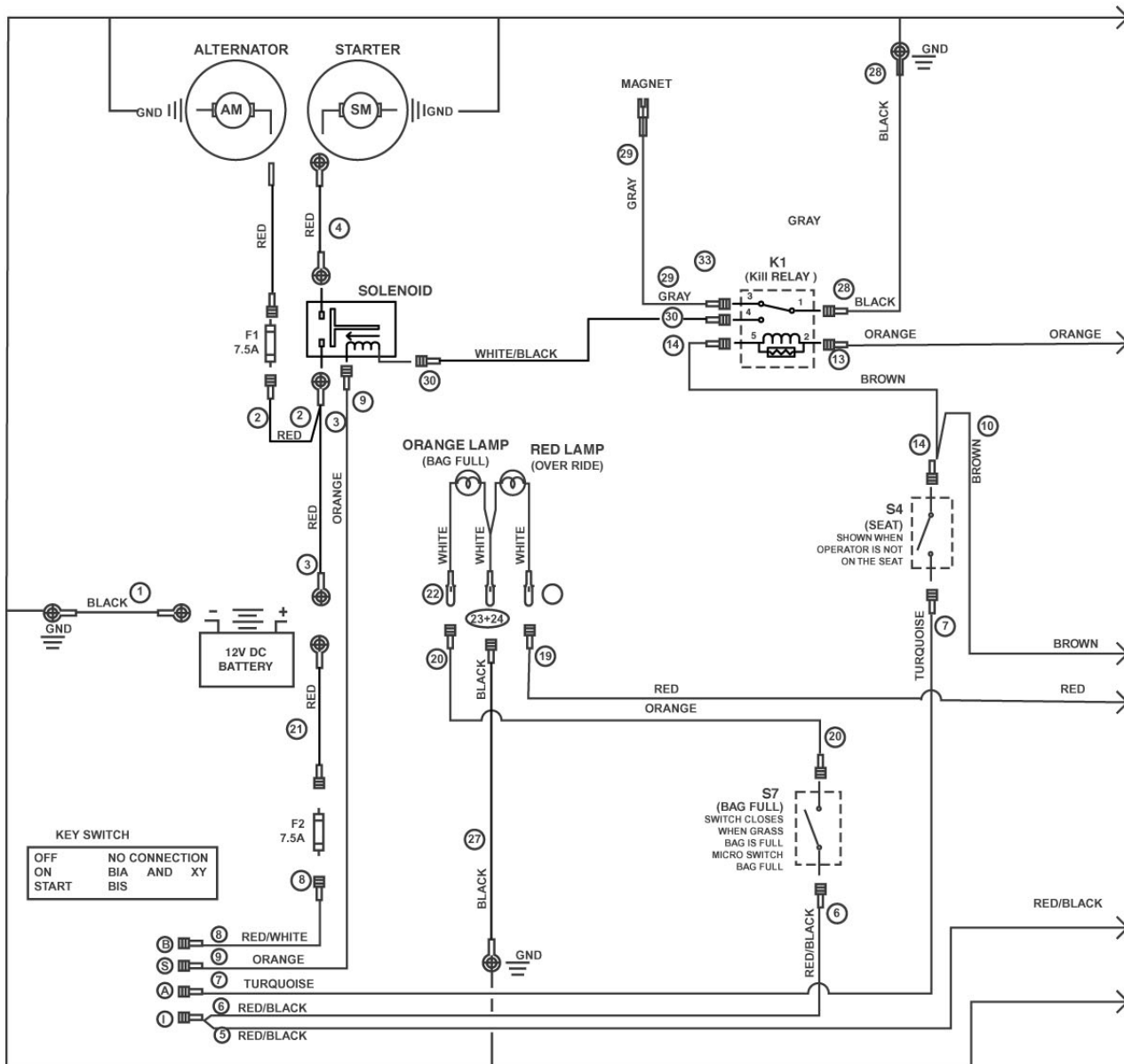

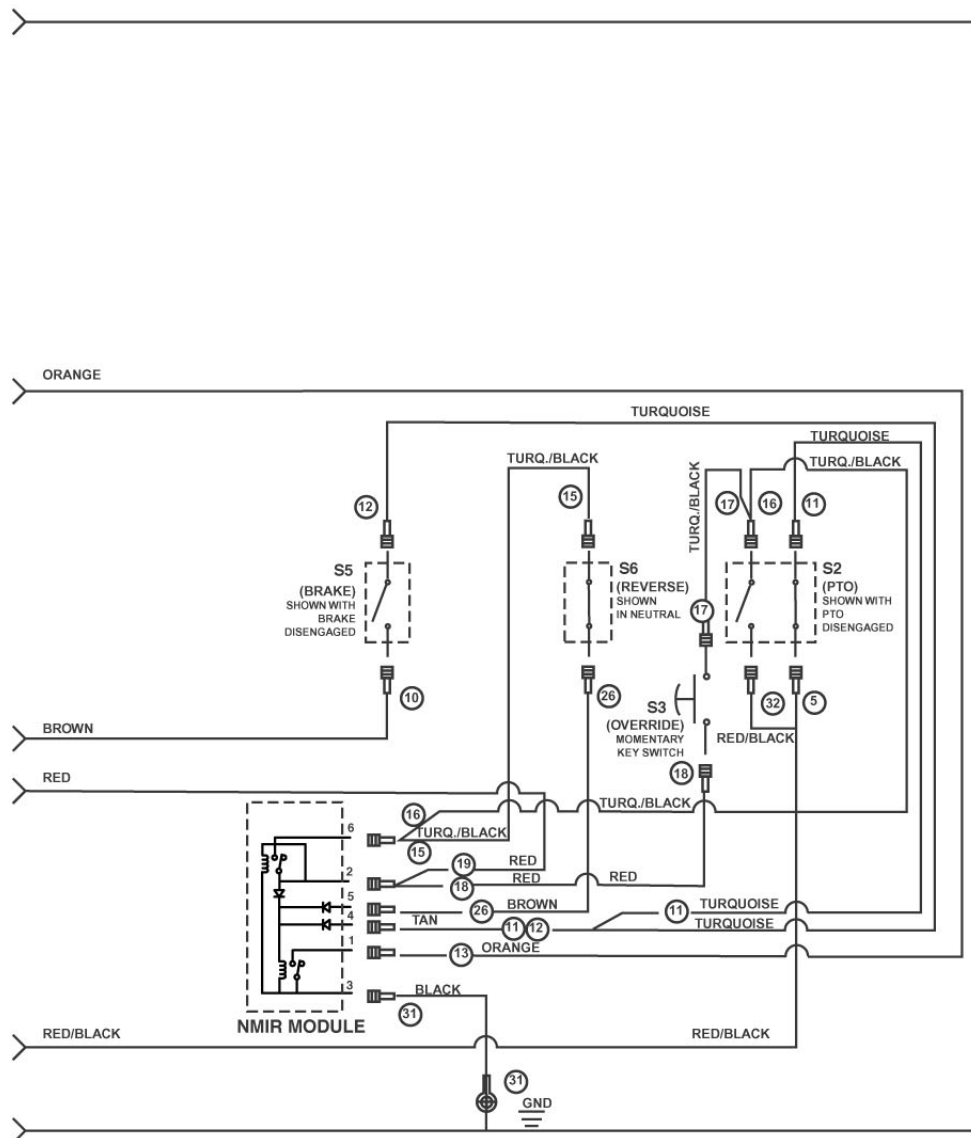

Circuits

## Starter Motor Circuit (ignition switch in "start")

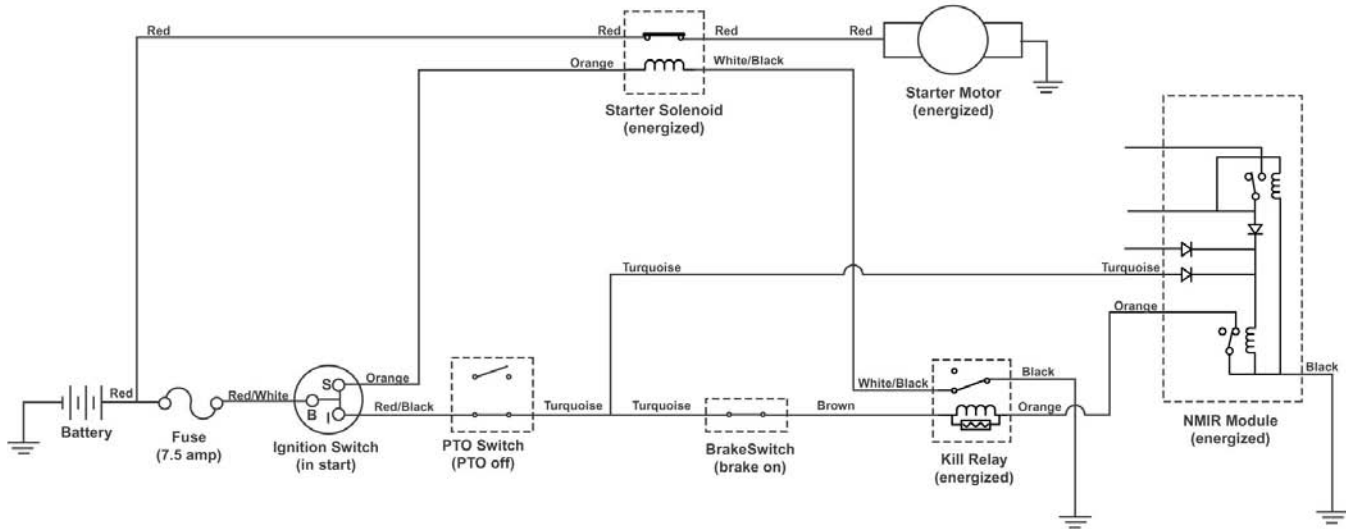

## Spark Circuit (ignition switch in "start")

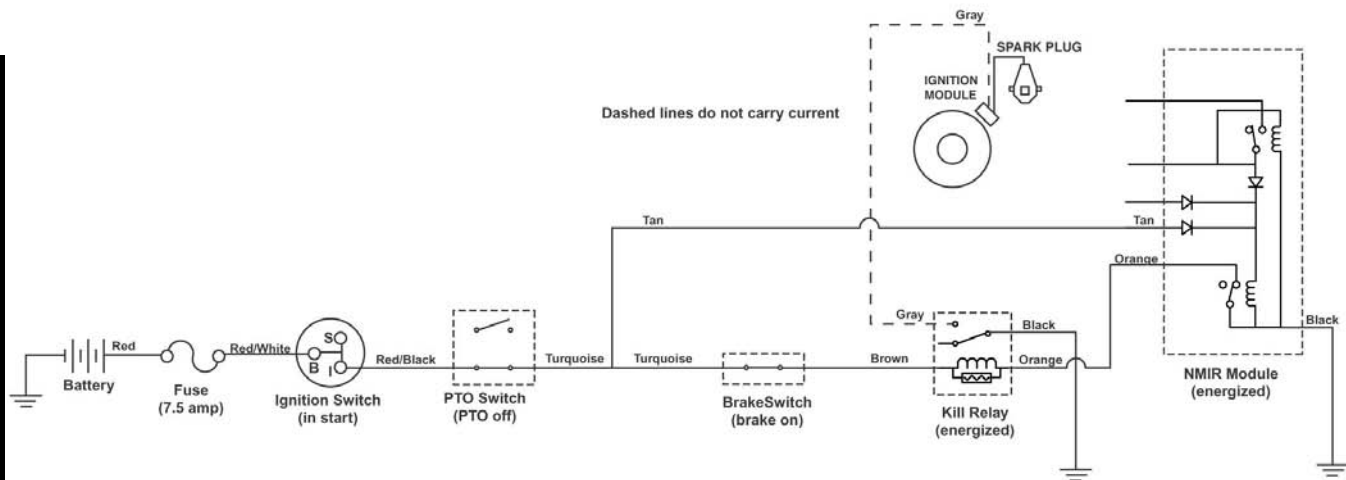

Circuits

Legend	
Black	Bk
Blue	Bu
Brown	Bn
Green	Gn
Grey	Gy
Orange	Or
Pink	Pk
Red	Re
Tan	T
Violet	Vio
White	W
Yellow	Y

**Spark Circuit**  
(ignition switch in "run")

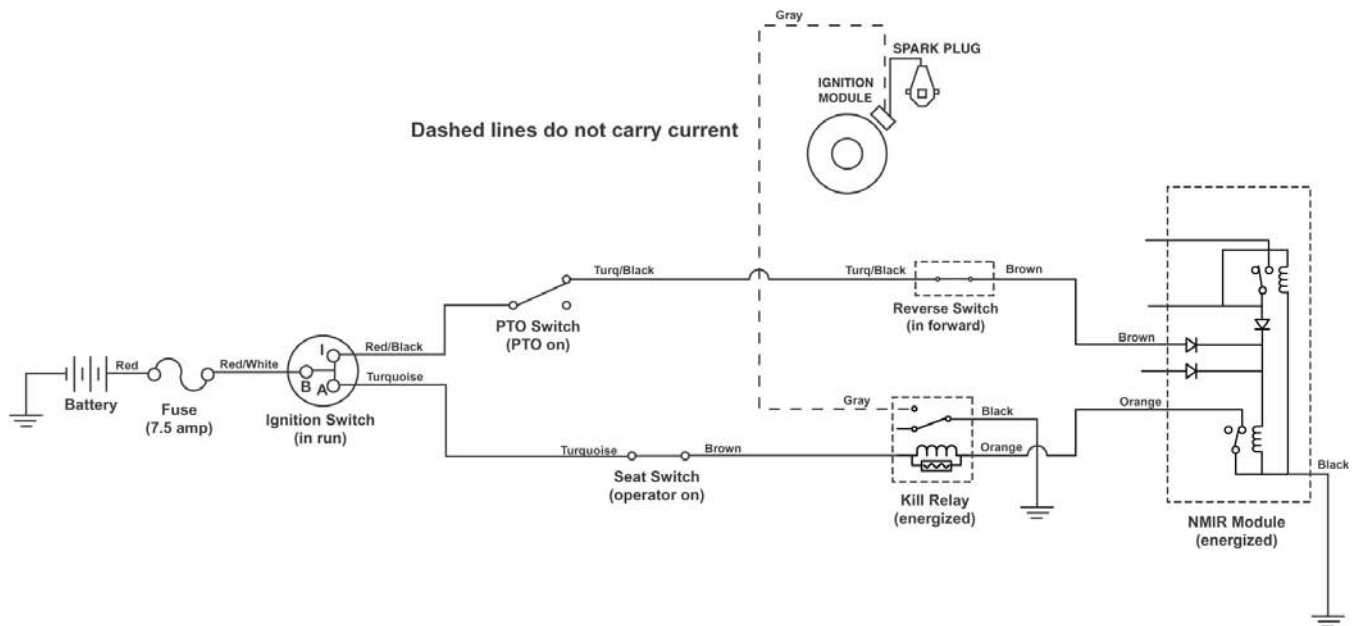

Legend	
Black	Bk
Blue	Bu
Brown	Bn
Green	Gn
Grey	Gy
Orange	Or
Pink	Pk
Red	Re
Tan	T
Violet	Vio
White	W
Yellow	Y

## Spark Circuit (in reverse, PTO "on")

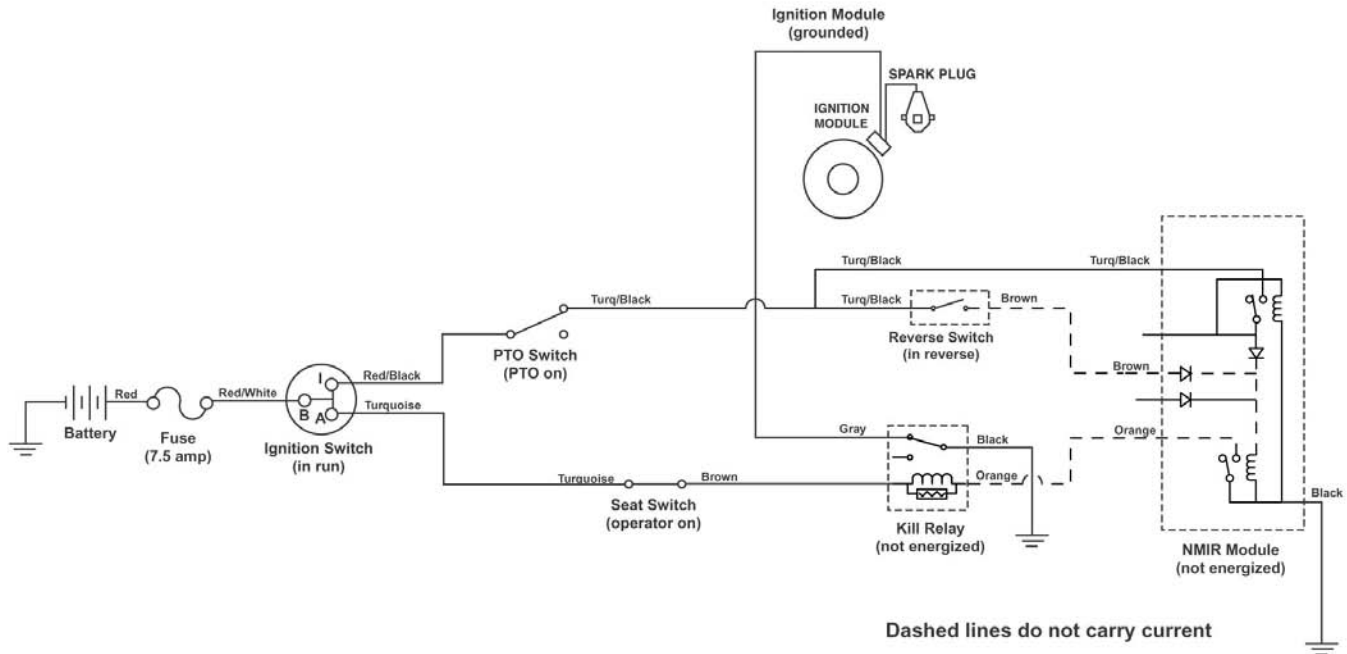

## Spark Circuit (in reverse, override key switch activated)

Legend	
Black	Bk
Blue	Bu
Brown	Bn
Green	Gn
Grey	Gy
Orange	Or
Pink	Pk
Red	Re
Tan	T
Violet	Vio
White	W
Yellow	Y

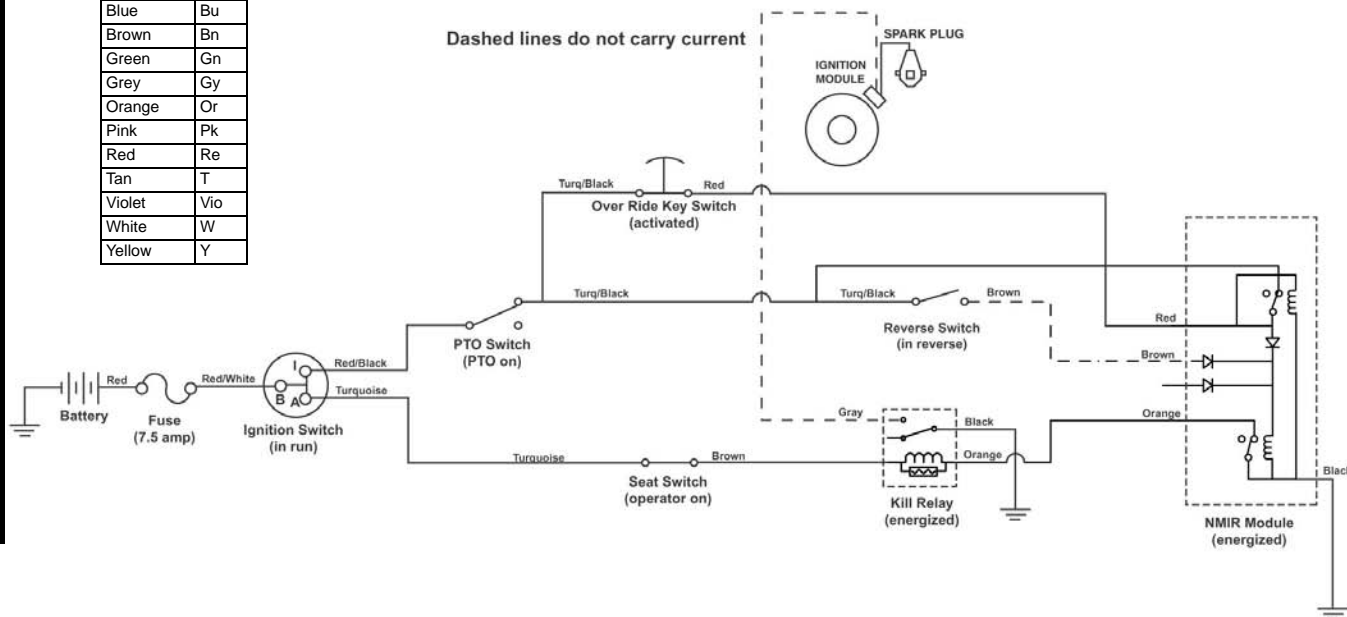



**Spark Circuit**  
(in reverse, PTO "on", override mode)

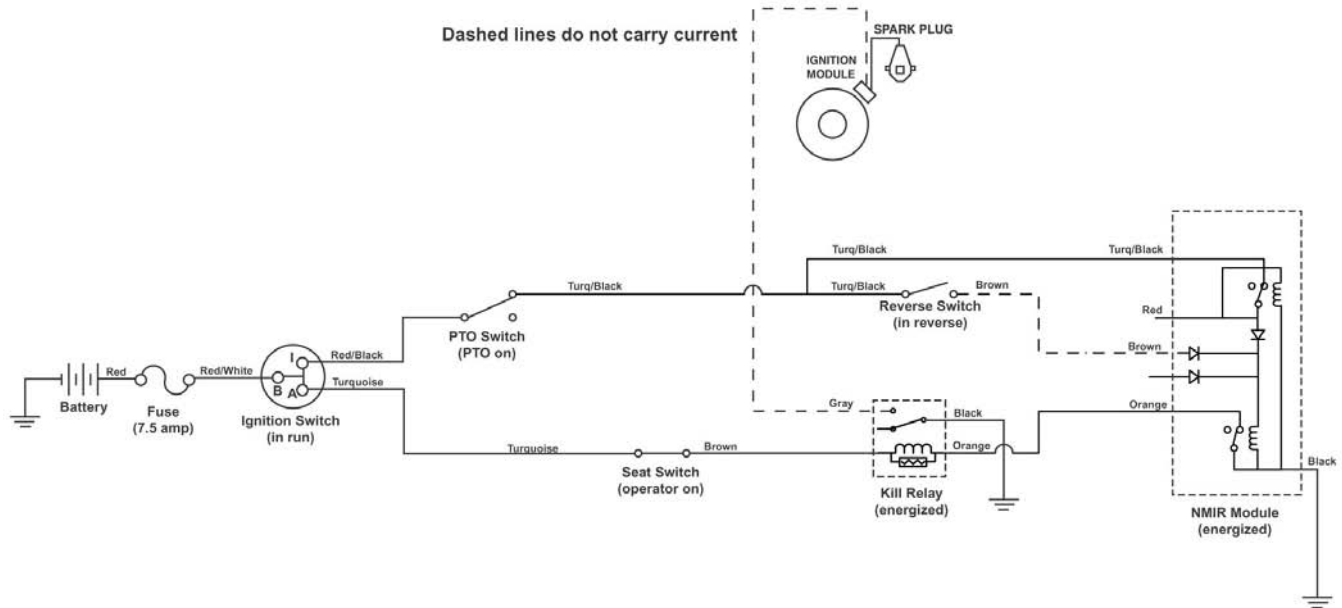

Legend	
Black	Bk
Blue	Bu
Brown	Bn
Green	Gn
Grey	Gy
Orange	Or
Pink	Pk
Red	Re
Tan	T
Violet	Vio
White	W
Yellow	Y

**Battery Charge Circuit**

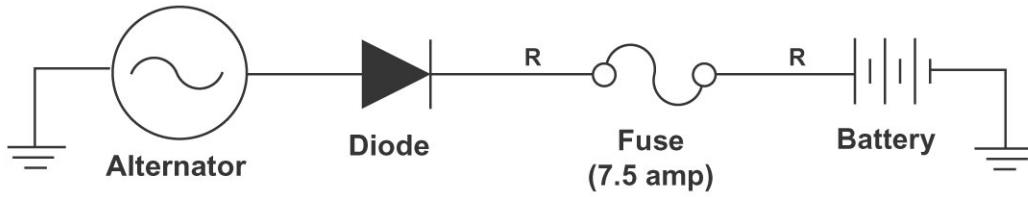

**Bag Full Circuit**  
(ignition switch in "run")

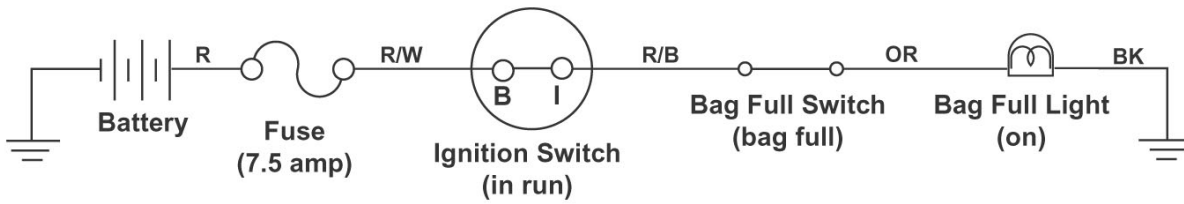

Legend	
Black	Bk
Blue	Bu
Brown	Bn
Green	Gn
Grey	Gy
Orange	Or
Pink	Pk
Red	Re
Tan	T
Violet	Vio
White	W
Yellow	Y



**1332-H International Information List (2002 - 2003)**

Wiring Diagrams . . . . . 22-2 & 22-3  
Circuit Diagrams  
    Starter Motor Circuit . . . . . 22-4  
    Spark Circuits . . . . . 22-4 - 22-7  
    Battery Charge Circuit . . . . . 22-7  
    Bag Full Circuit . . . . . 22-8

Wiring Diagram

Wiring Diagram

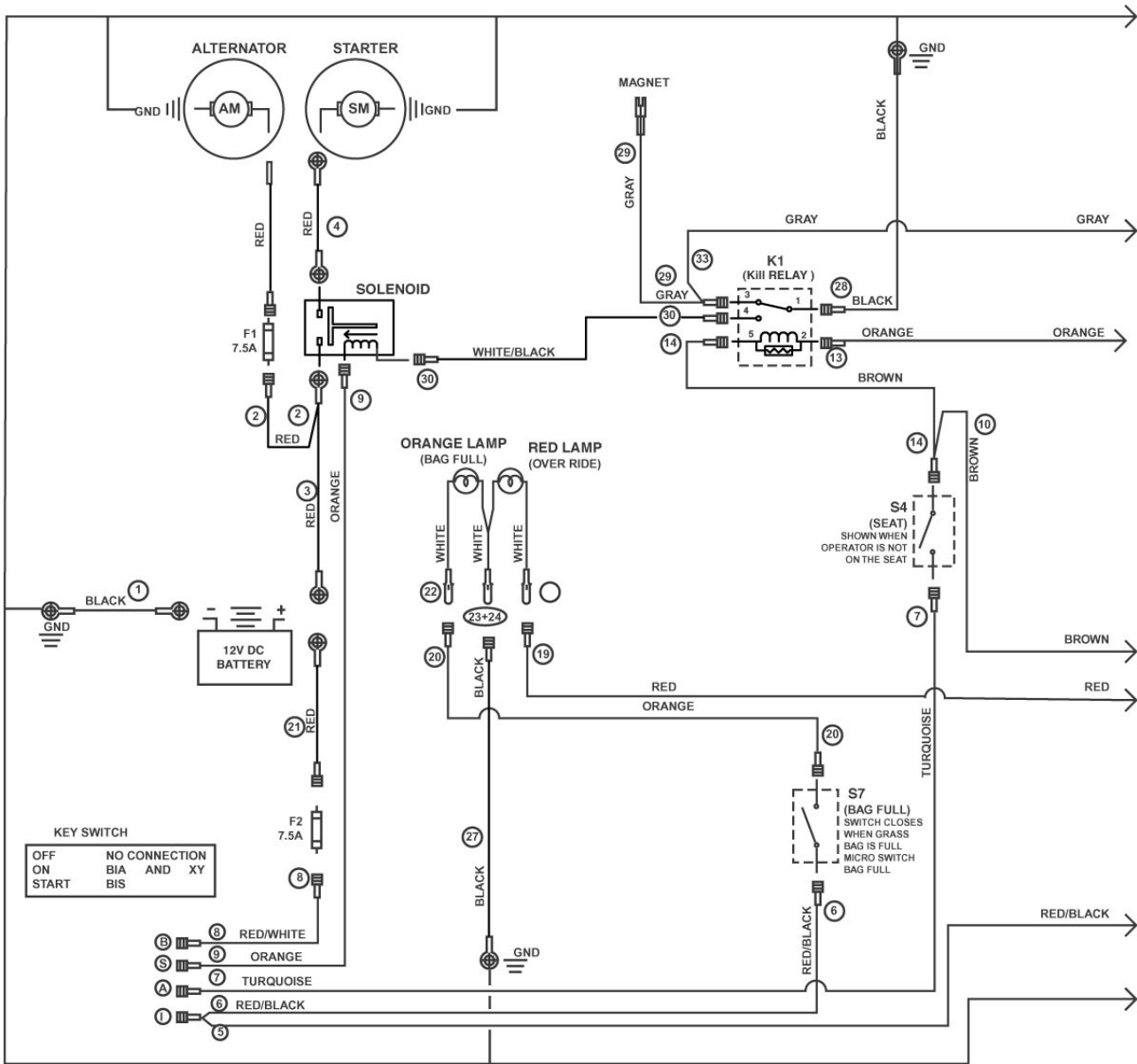

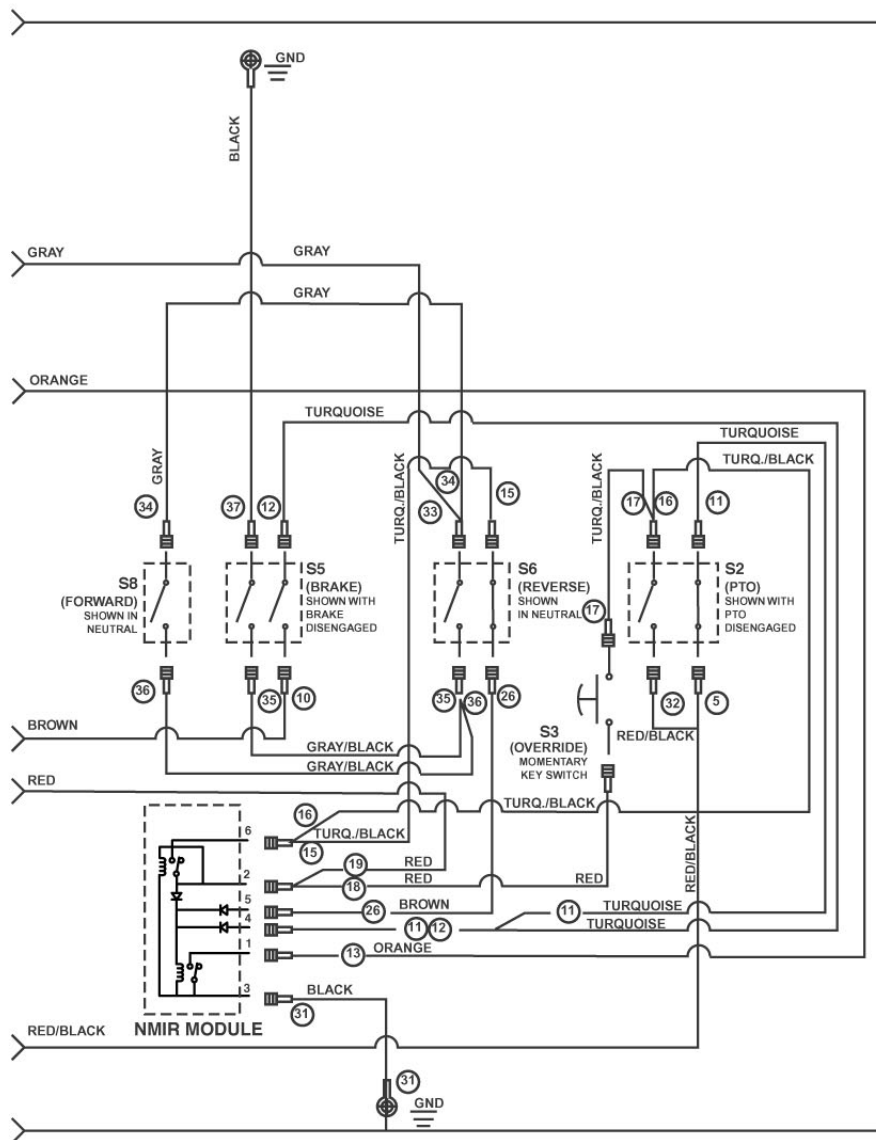

## Starter Motor Circuit (ignition switch in "start")

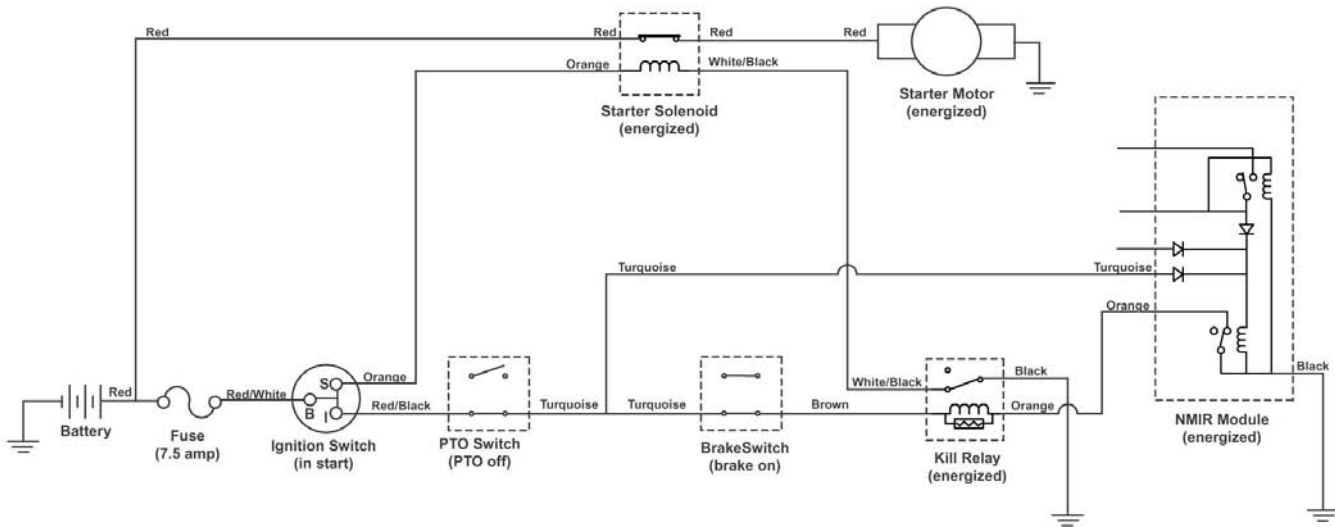

## Spark Circuit (ignition switch in "start")

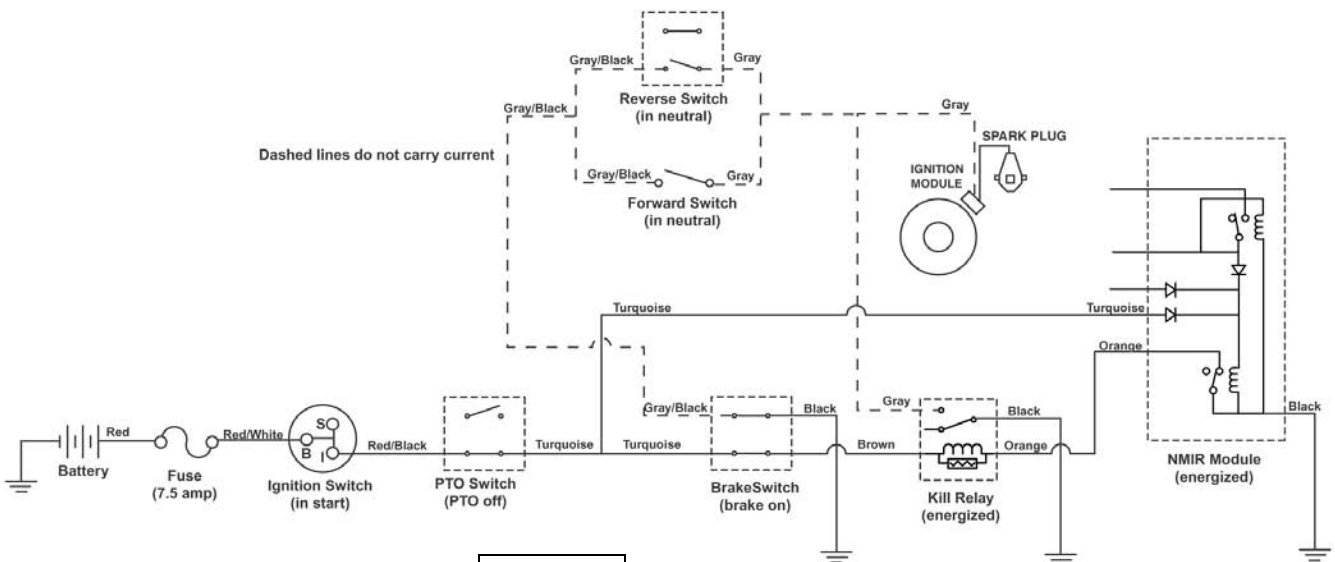

Legend	
Black	Bk
Blue	Bu
Brown	Bn
Green	Gn
Grey	Gy
Orange	Or
Pink	Pk
Red	Re
Tan	T
Violet	Vio
White	W
Yellow	Y

**Spark Circuit**  
(ignition switch in "run")

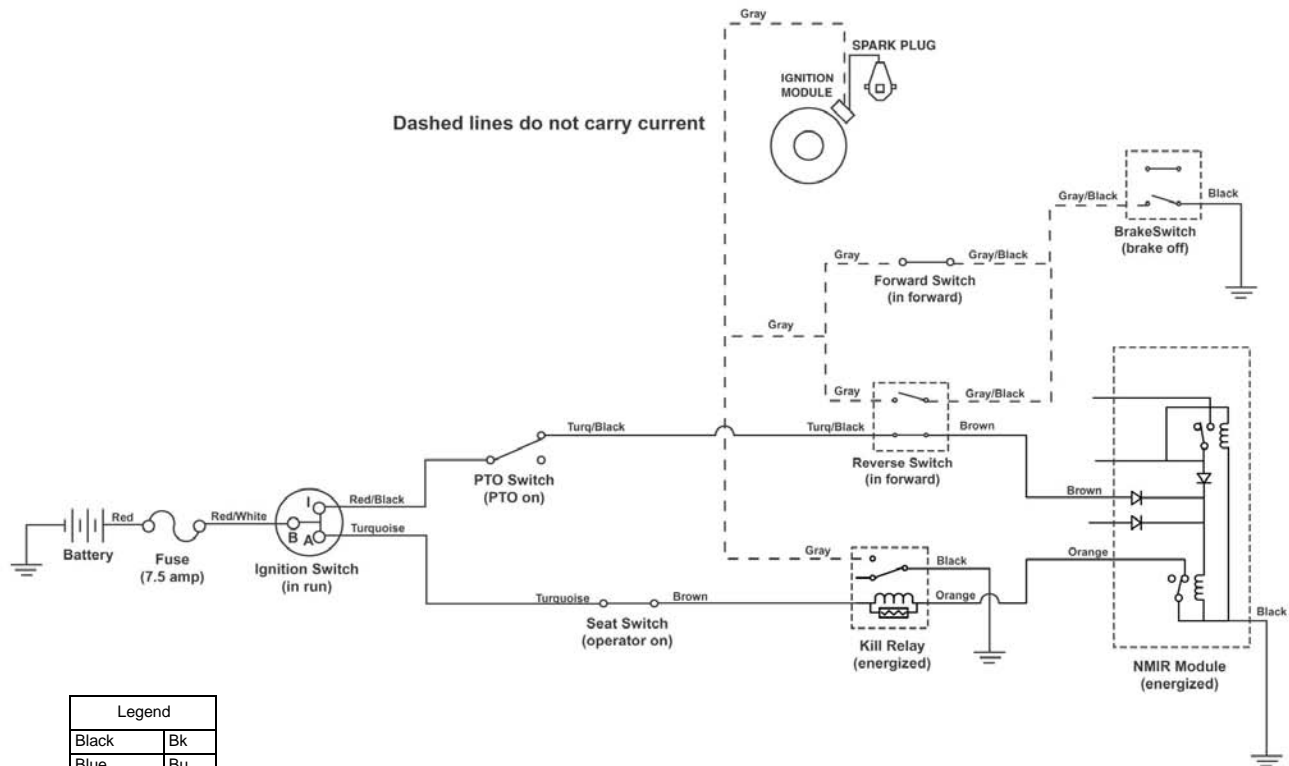

Legend	
Black	Bk
Blue	Bu
Brown	Bn
Green	Gn
Grey	Gy
Orange	Or
Pink	Pk
Red	Re
Tan	T
Violet	Vio
White	W
Yellow	Y

## Spark Circuit (in reverse, PTO "on")

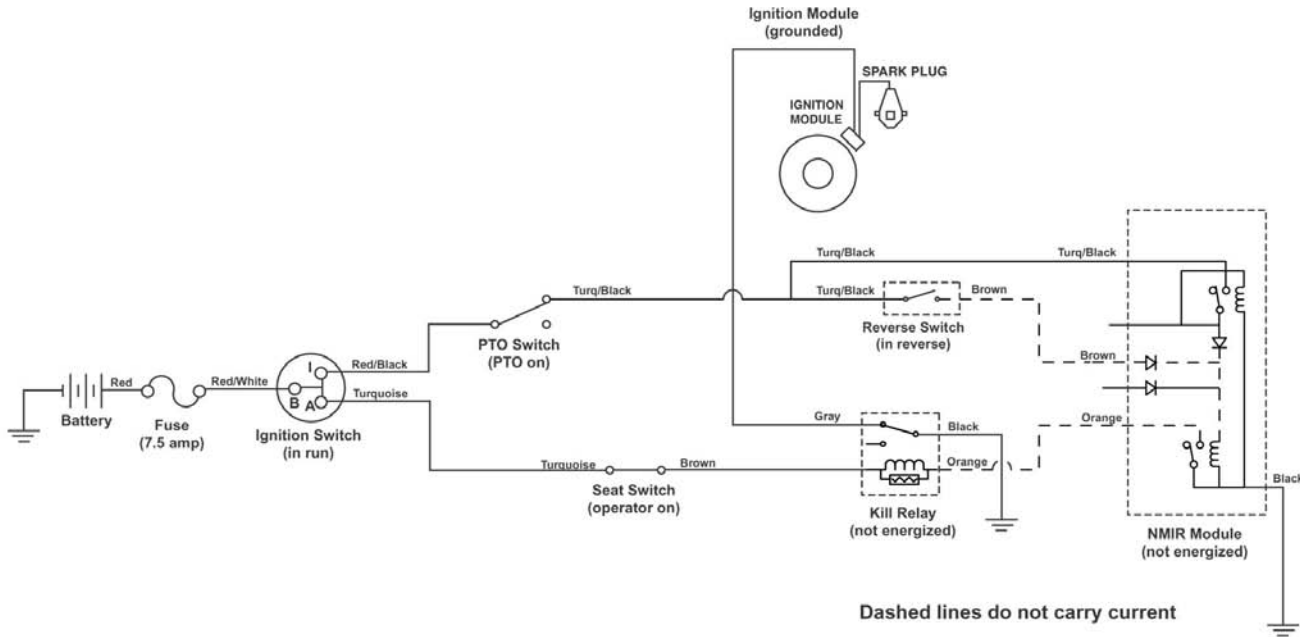

## Spark Circuit (in reverse, override key switch activated)

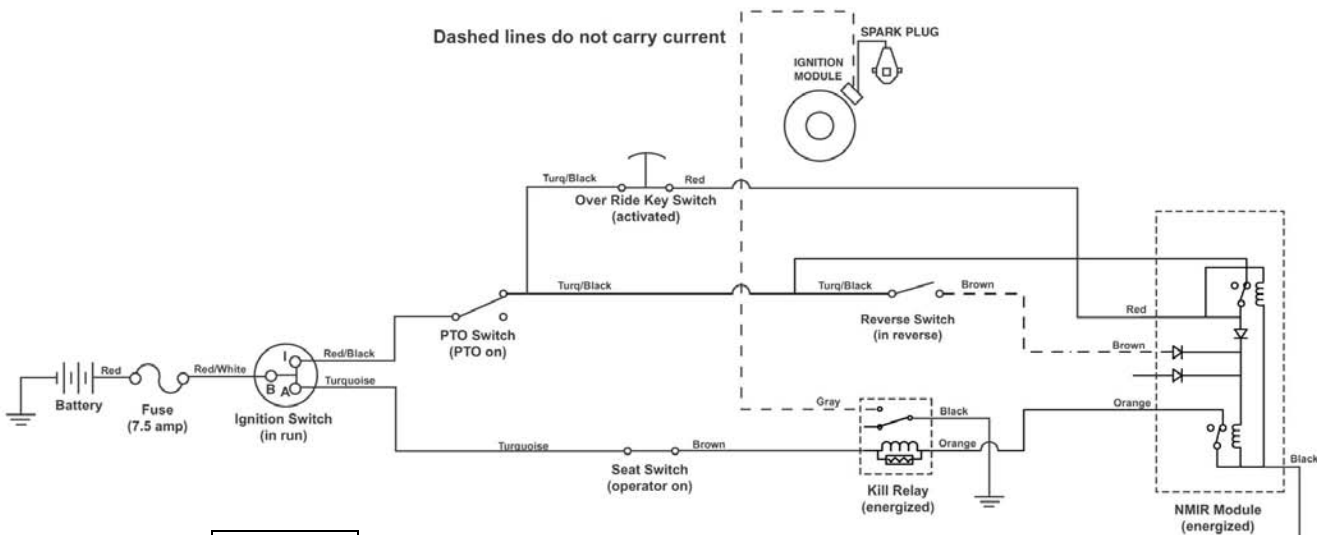

Legend	
Black	Bk
Blue	Bu
Brown	Bn
Green	Gn
Grey	Gy
Orange	Or
Pink	Pk
Red	Re
Tan	T
Violet	Vio
White	W
Yellow	Y



**Spark Circuit**

(in reverse, PTO "on", override mode)

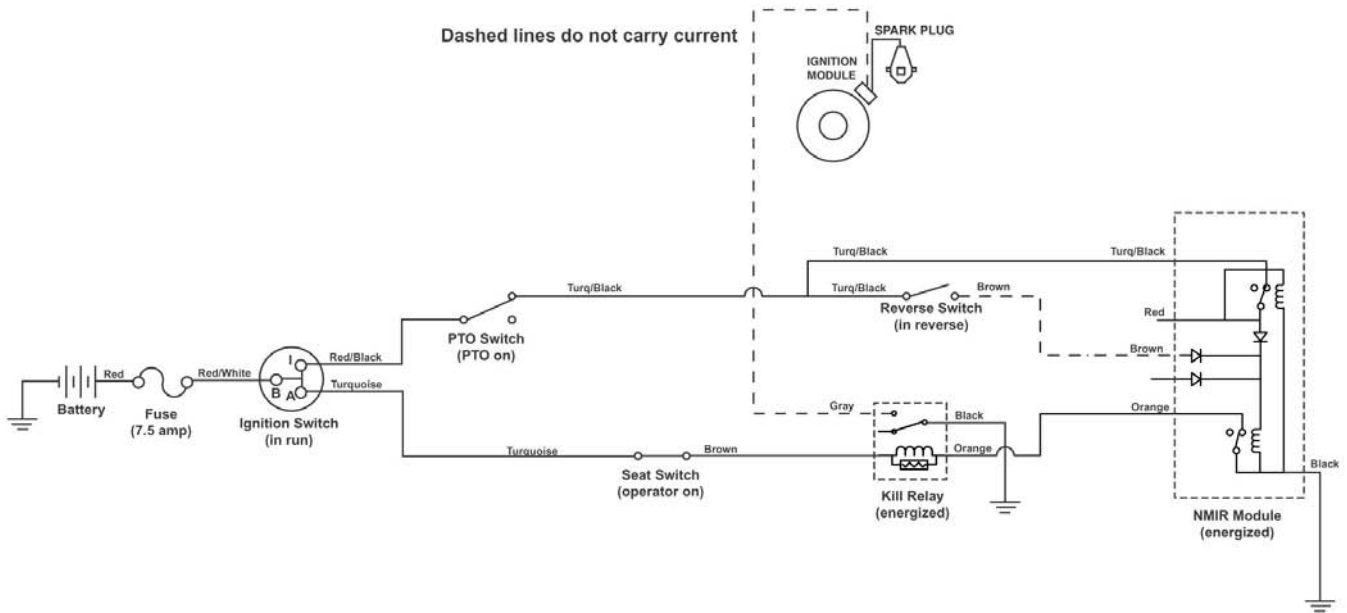

**Battery Charge Circuit**

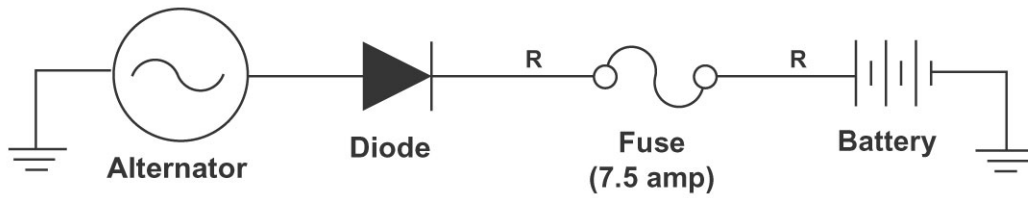

Legend	
Black	Bk
Blue	Bu
Brown	Bn
Green	Gn
Grey	Gy
Orange	Or
Pink	Pk
Red	Re
Tan	T
Violet	Vio
White	W
Yellow	Y

**Circuits**

**Bag Full Circuit**  
(ignition switch in "run")

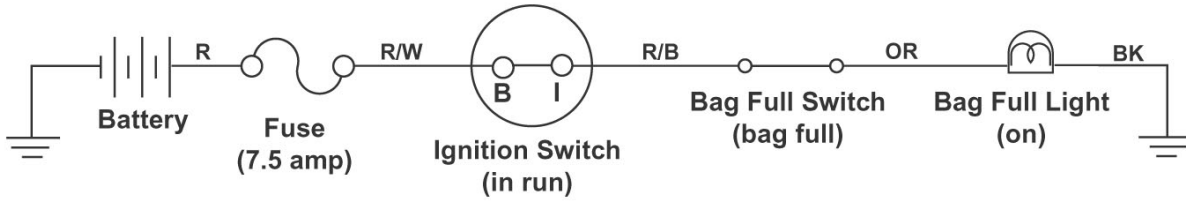

Legend	
Black	Bk
Blue	Bu
Brown	Bn
Green	Gn
Grey	Gy
Orange	Or
Pink	Pk
Red	Re
Tan	T
Violet	Vio
White	W
Yellow	Y



**170-D International Information List (2002 - 2003)**

Wiring Diagrams . . . . . 23-2 & 23-3  
Circuit Diagrams  
    Starter Motor Circuit . . . . . 23-4  
    Spark Circuits . . . . . 23-4 & 23-5  
    Reverse Operating System Circuits .23-6 - 23-10  
    Charging Circuit . . . . . 23-10  
    Light Circuit . . . . . 23-11  
    Hourmeter Circuit . . . . . 23-11  
    Bag Full Circuit . . . . . 23-11

Wiring Diagram

Wiring Diagram

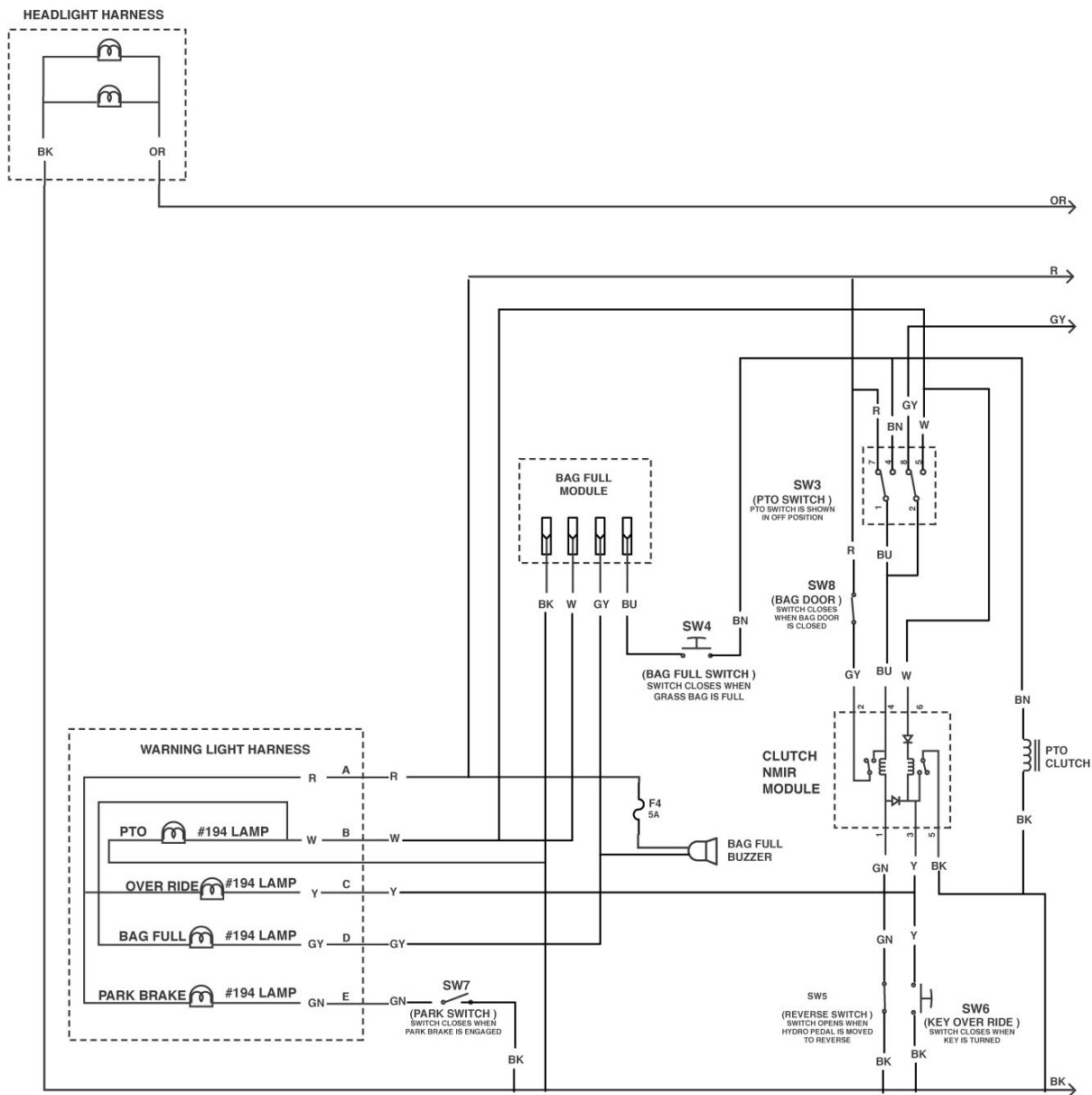

Wiring Diagram

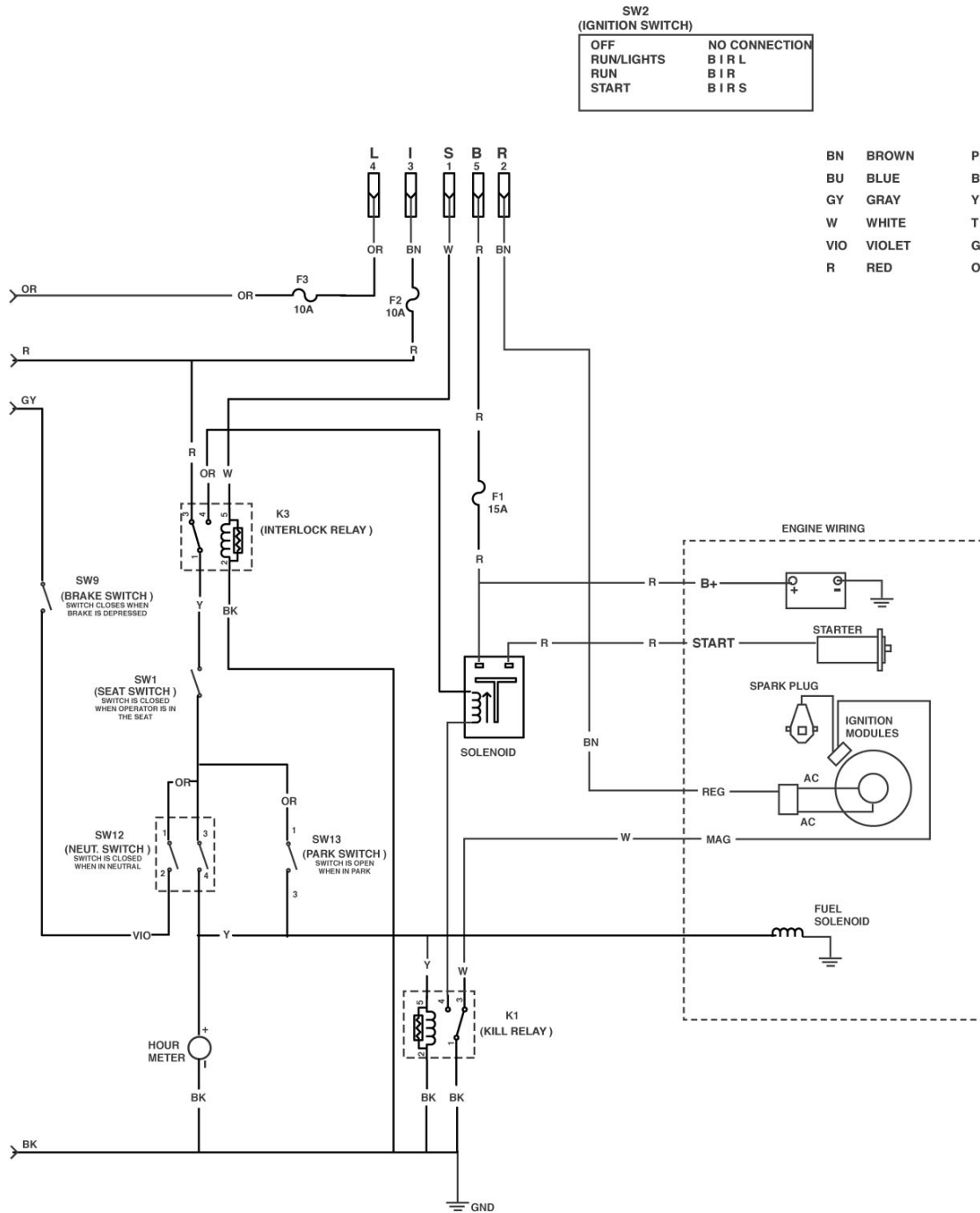

Wiring Diagram

## Starter Motor Circuit (ignition switch in "start")

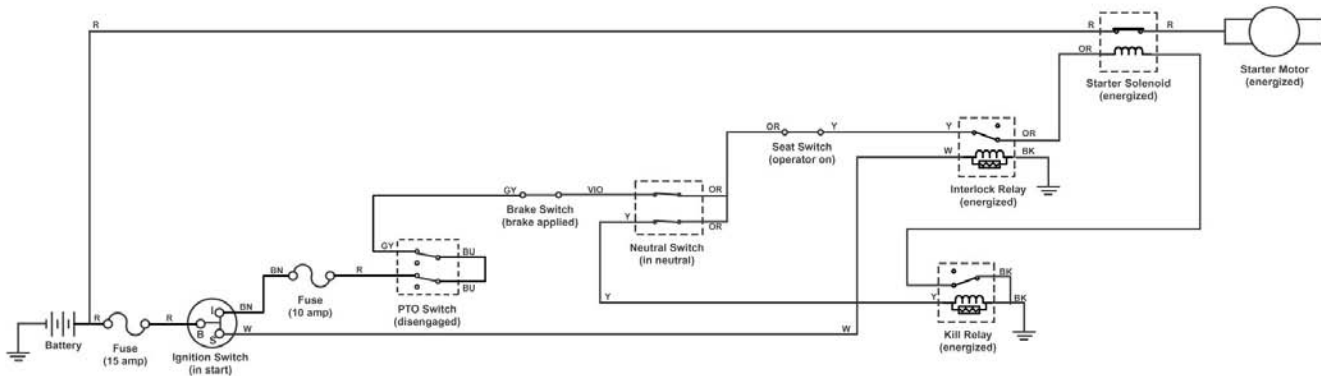

## Spark Circuit (ignition switch in "start" position)

Legend	
Black	Bk
Blue	Bu
Brown	Bn
Green	Gn
Grey	Gy
Orange	Or
Pink	Pk
Red	Re
Tan	T
Violet	Vio
White	W
Yellow	Y

Dashed lines do not carry current

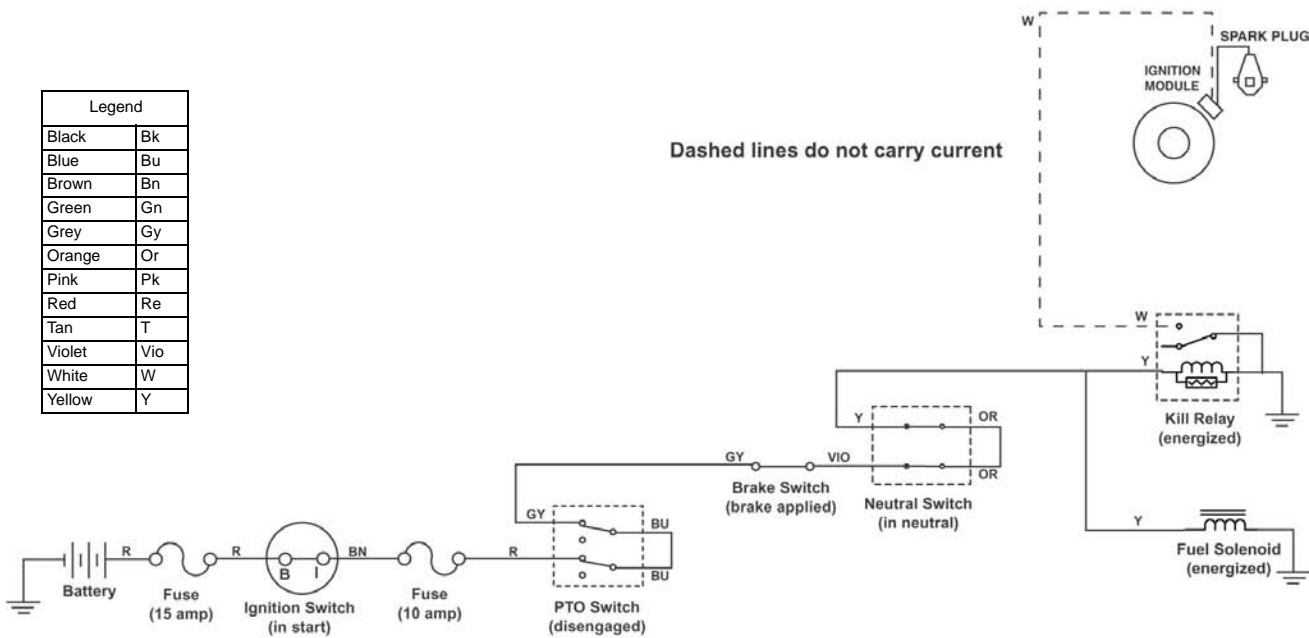

Circuits

**Spark Circuit**  
(ignition switch in "run")

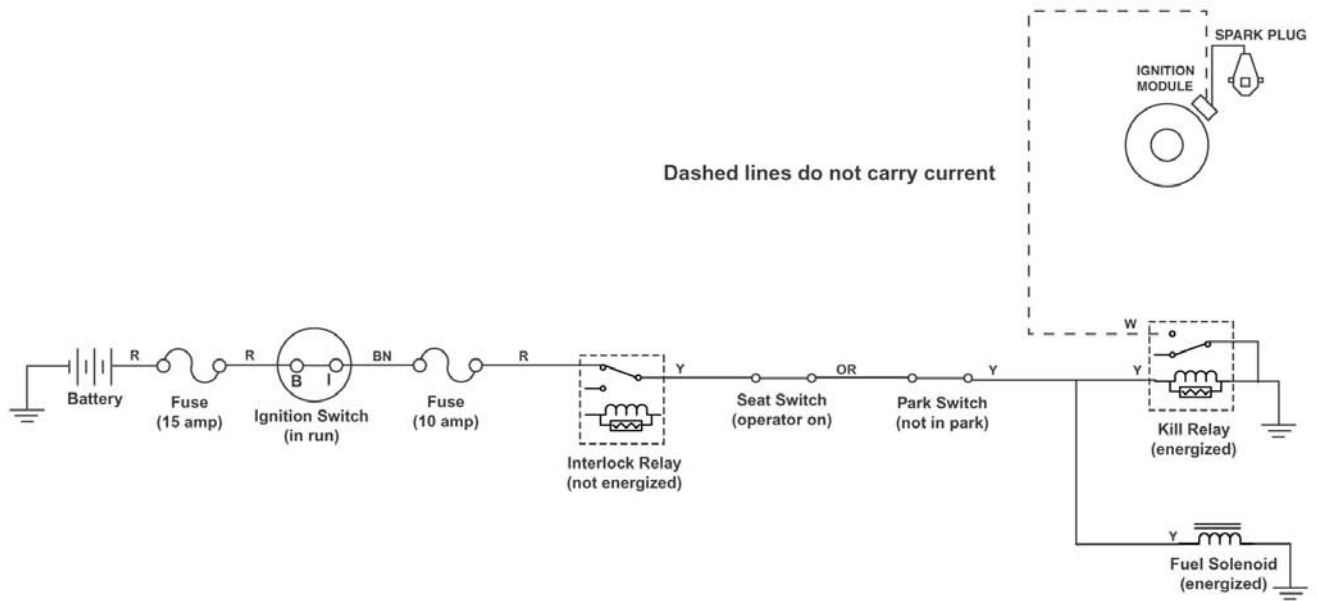

Legend	
Black	Bk
Blue	Bu
Brown	Bn
Green	Gn
Grey	Gy
Orange	Or
Pink	Pk
Red	Re
Tan	T
Violet	Vio
White	W
Yellow	Y

## Reverse Operating System Circuit

(PTO "off", in forward)

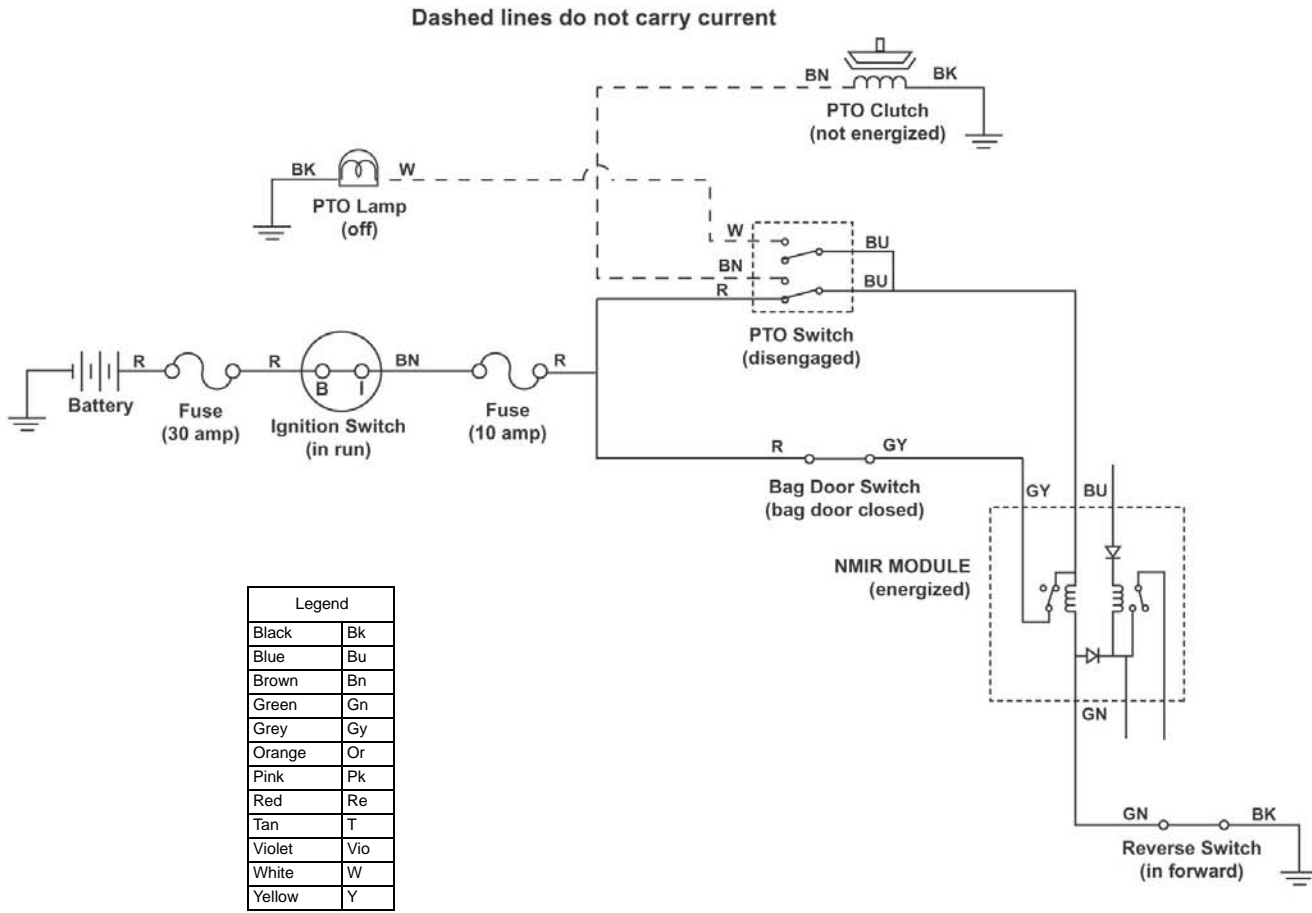



**Reverse Operating System Circuit**  
(PTO "on", in forward)

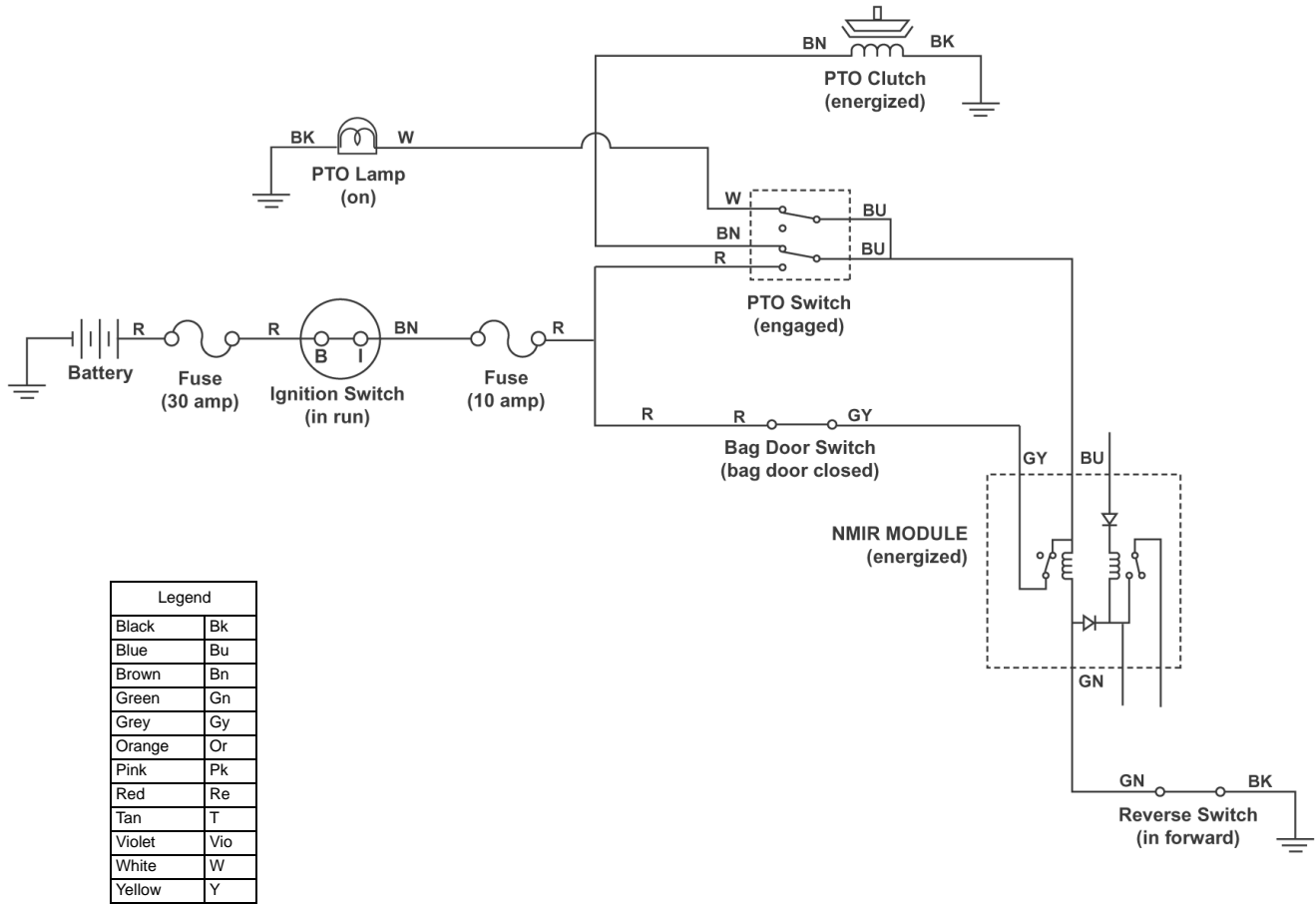

Legend	
Black	Bk
Blue	Bu
Brown	Bn
Green	Gn
Grey	Gy
Orange	Or
Pink	Pk
Red	Re
Tan	T
Violet	Vio
White	W
Yellow	Y

## Reverse Operating System Circuit (PTO "on", in reverse)

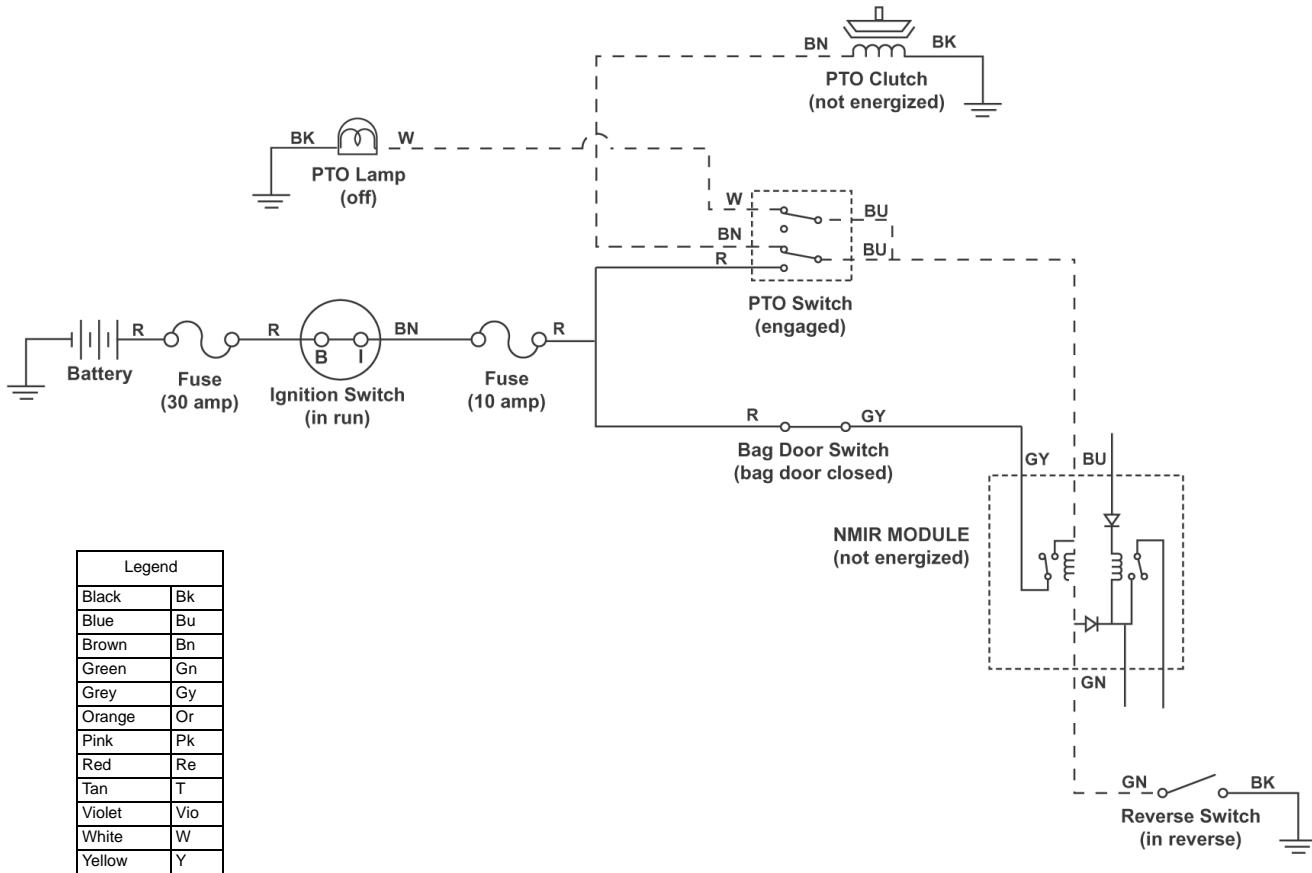

Legend	
Black	Bk
Blue	Bu
Brown	Bn
Green	Gn
Grey	Gy
Orange	Or
Pink	Pk
Red	Re
Tan	T
Violet	Vio
White	W
Yellow	Y

**Reverse Operating System Circuit**  
(Override key switch "activated")

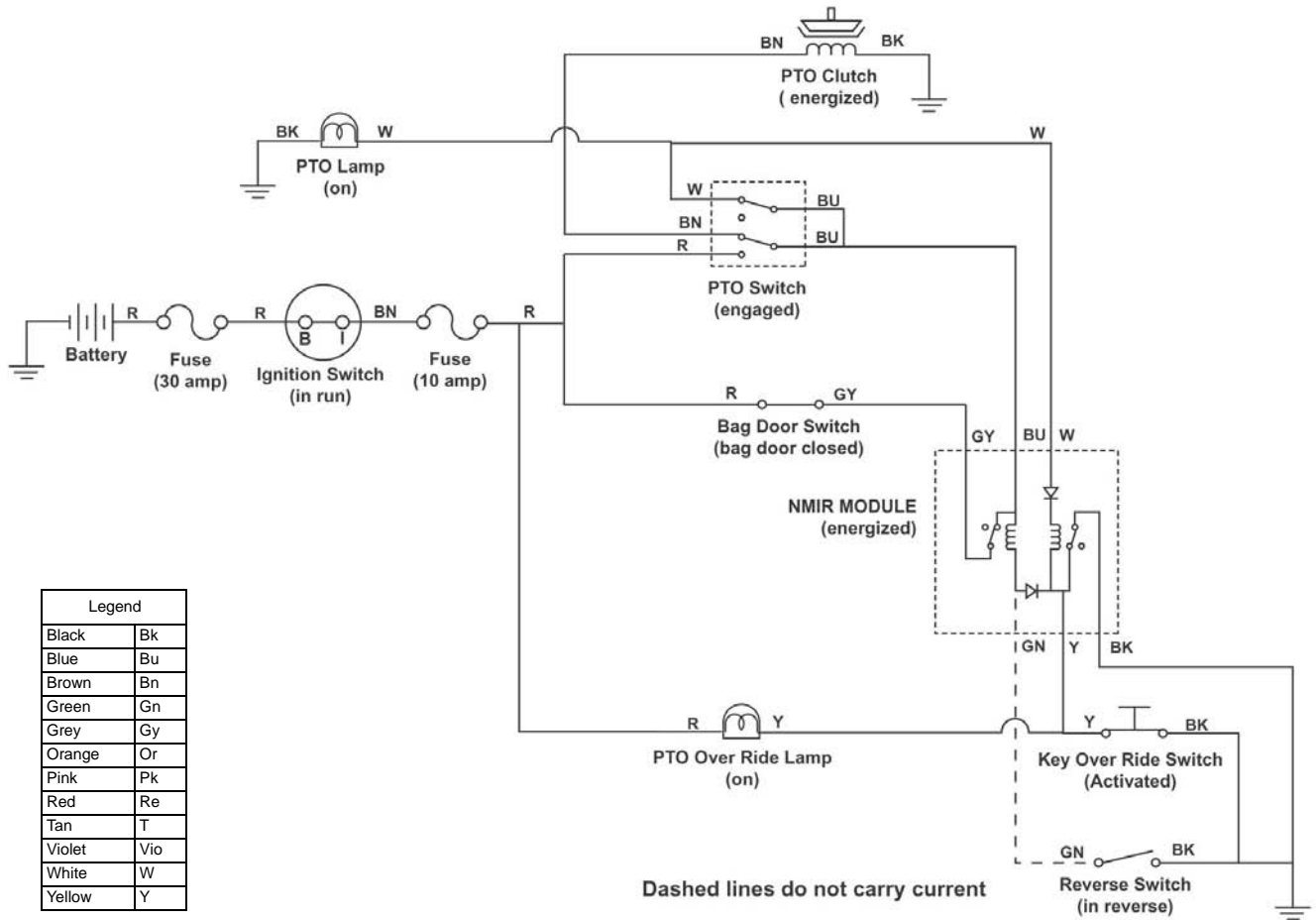

**Circuits**

**Reverse Operating System Circuit**

(PTO "on", in reverse, override mode)

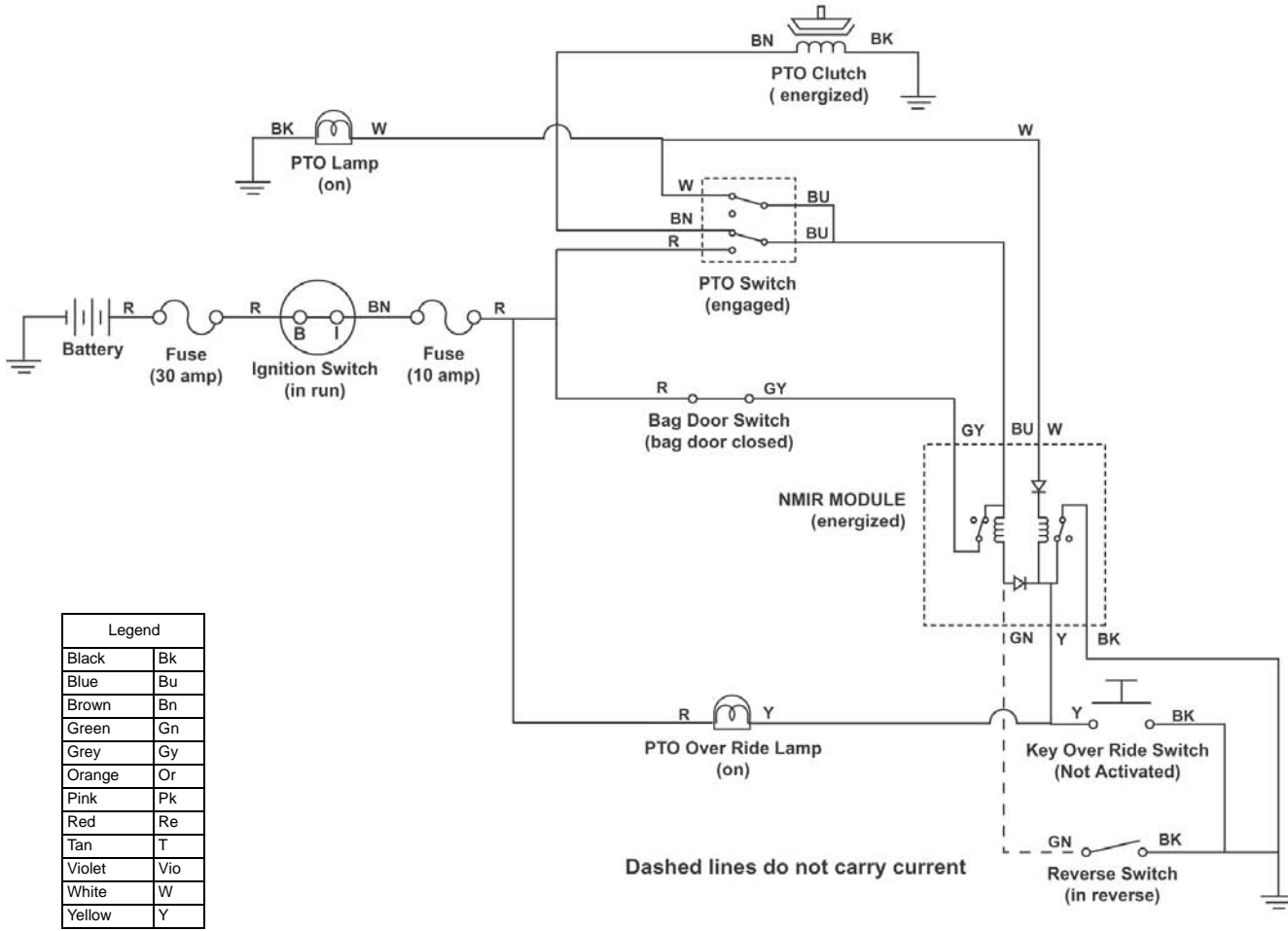

**Circuits**

**Charging Circuit**

(ignition switch in "run")

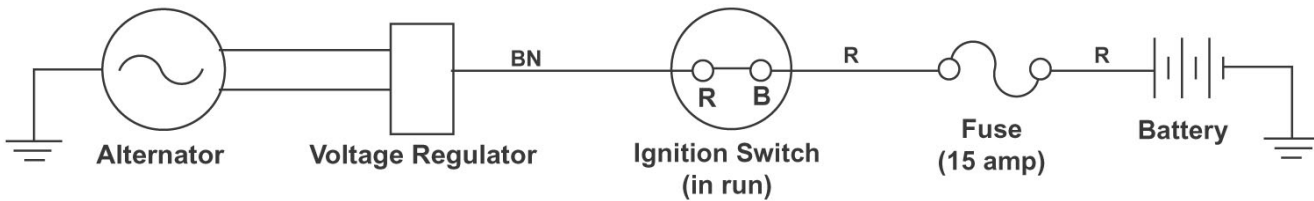

**Light Circuit**  
(ignition switch in "run/lights")

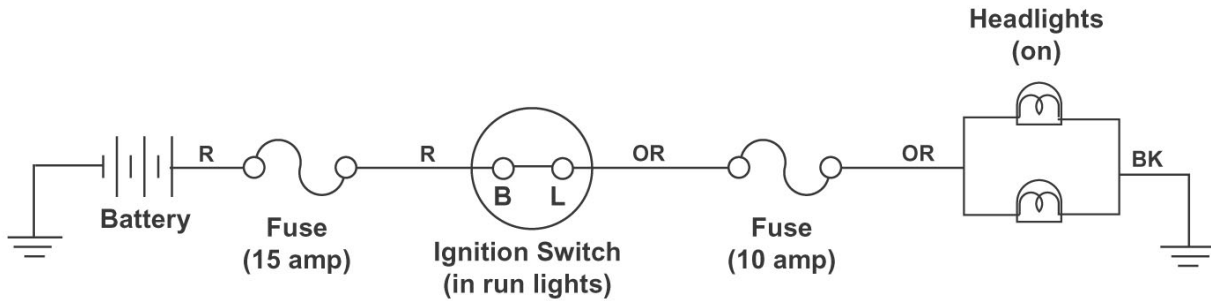

**Hourmeter Circuit**  
(ignition switch in "run")

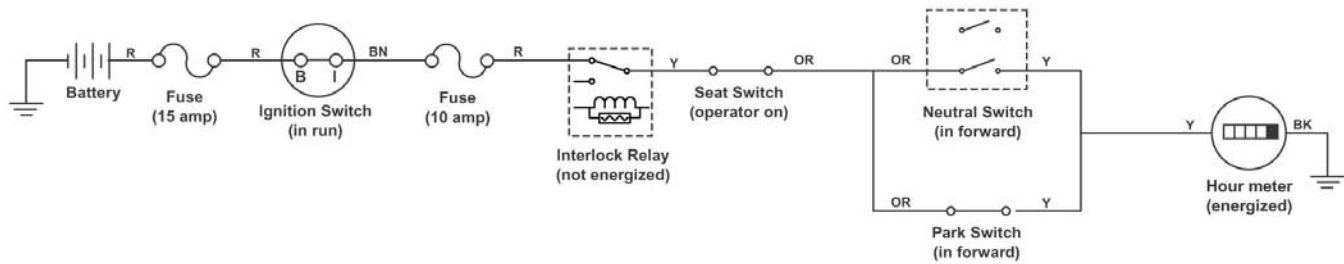

**Bag Full Circuit**  
(ignition switch in "run")

Legend	
Black	Bk
Blue	Bu
Brown	Bn
Green	Gn
Grey	Gy
Orange	Or
Pink	Pk
Red	Re
Tan	T
Violet	Vio
White	W
Yellow	Y

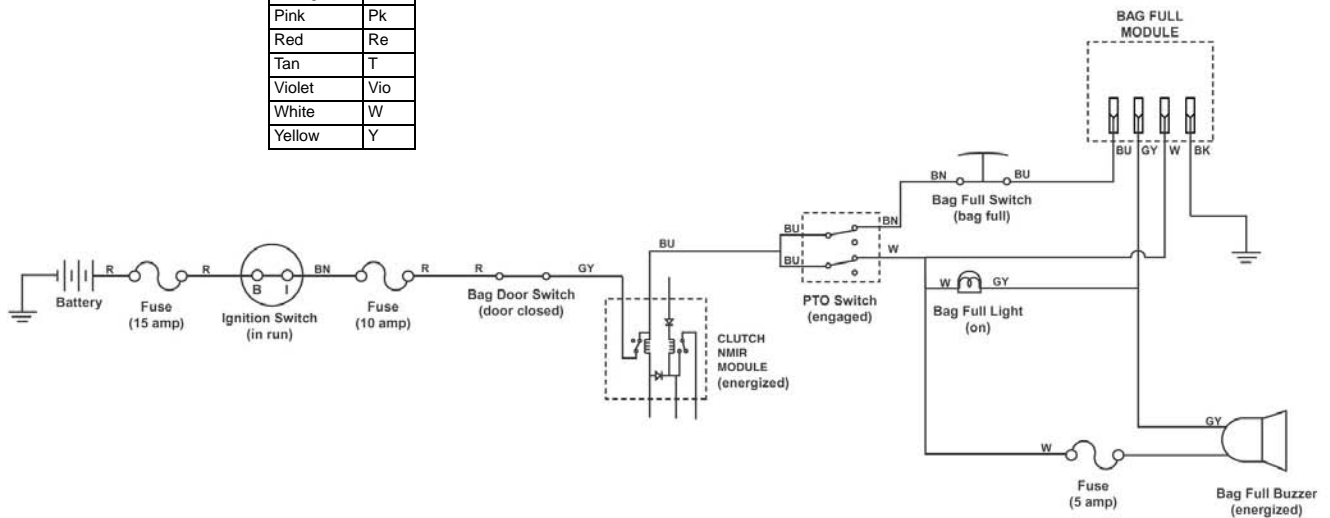

**Circuits**

**This page intentionally left blank**



**190-D International Information List (2002 - 2003)**

Wiring Diagram . . . . . 24-2 & 24-3  
Circuit Diagrams  
  Starter Motor Circuit . . . . . 24-4  
  Spark Circuits . . . . . 24-4  
  Reverse Operating System Circuits . . 24-6 - 24-10  
  Charging Circuit . . . . . 24-10  
  Light Circuit . . . . . 24-11  
  Hourmeter Circuit . . . . . 24-11  
  Bag Full Circuit . . . . . 24-11  
  Cruise Control Circuit . . . . . 24-12

Wiring Diagram

Wiring Diagram

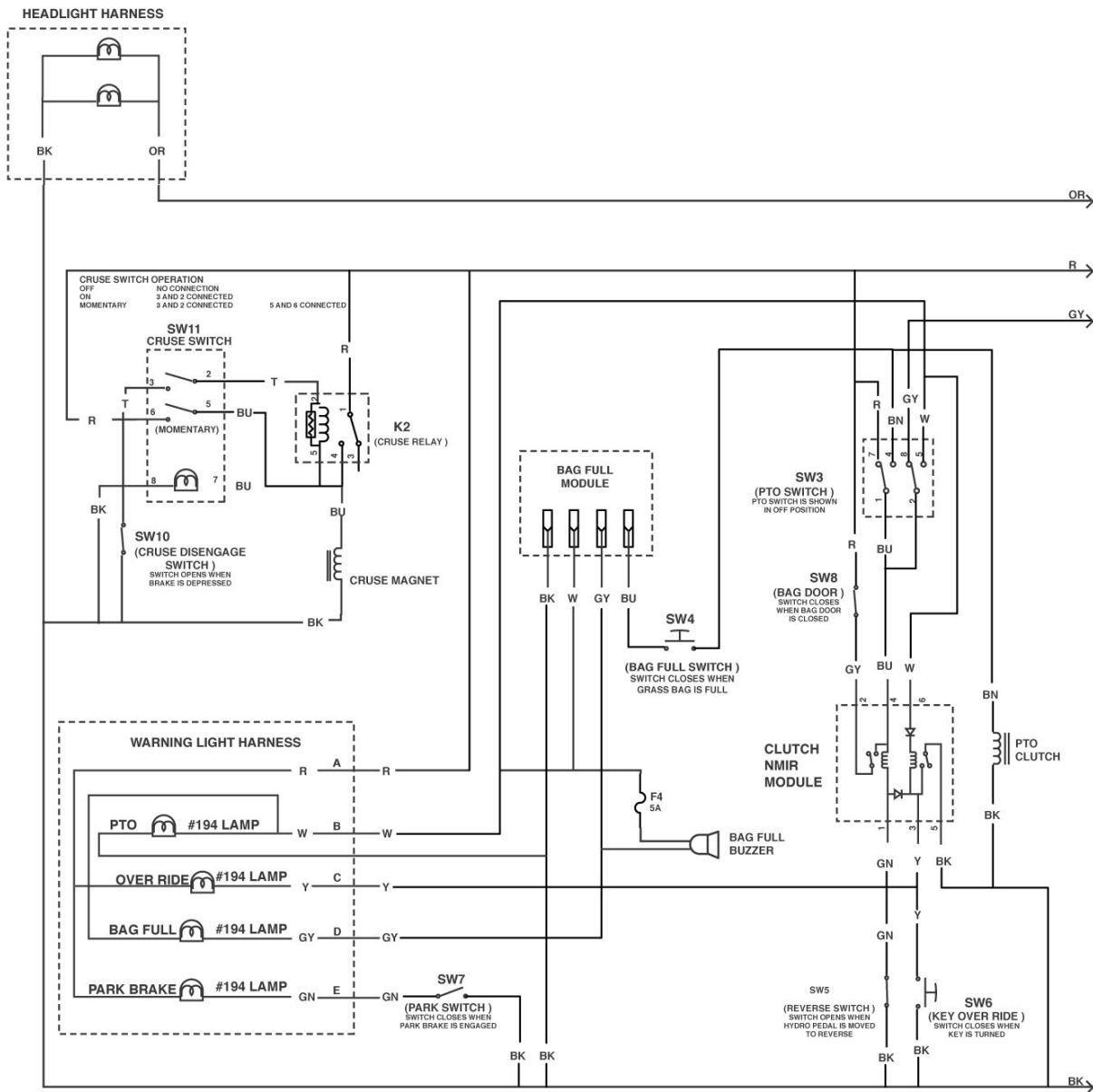



Wiring Diagram

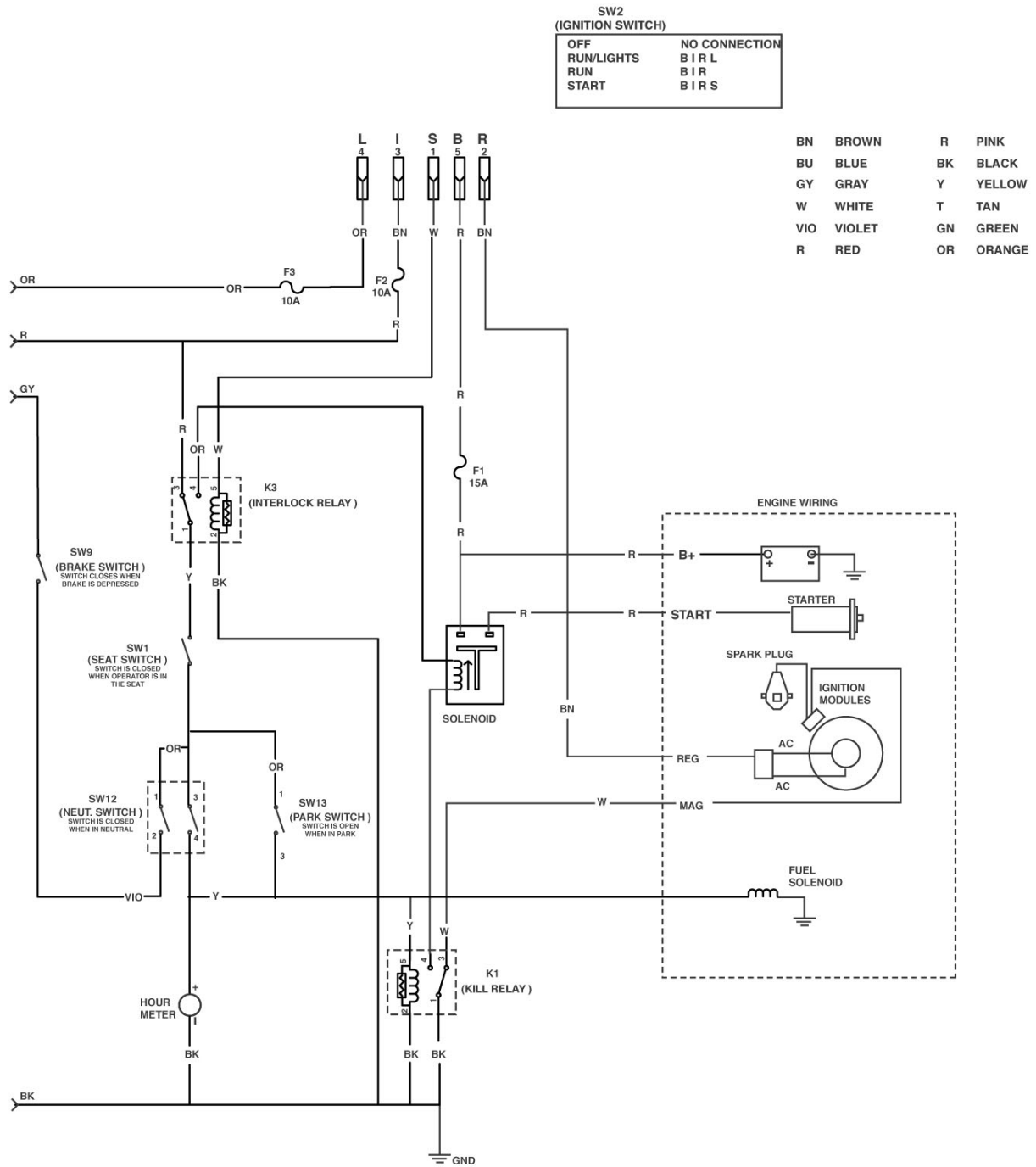

Wiring Diagram

## Starter Motor Circuit (ignition switch in "start")

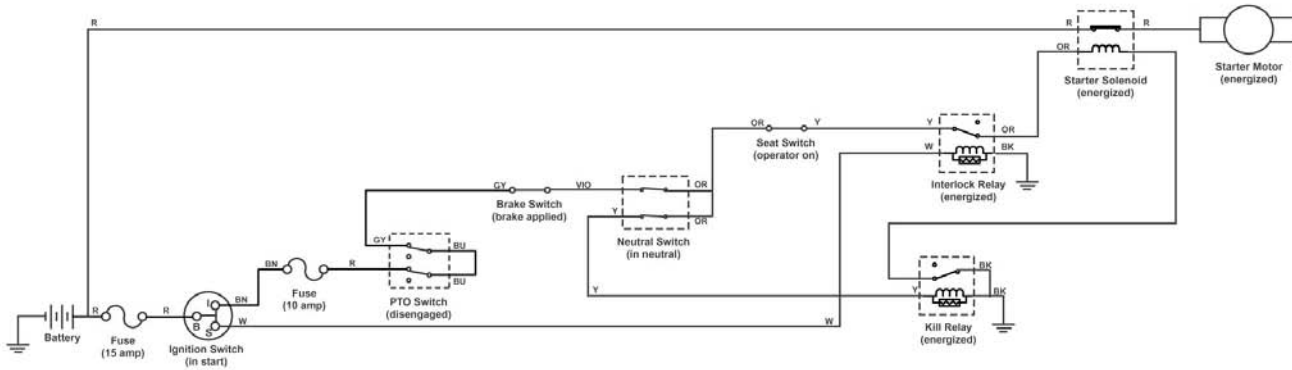

## Spark Circuit (ignition switch in "start" position)

Legend	
Black	Bk
Blue	Bu
Brown	Bn
Green	Gn
Grey	Gy
Orange	Or
Pink	Pk
Red	Re
Tan	T
Violet	Vio
White	W
Yellow	Y

Dashed lines do not carry current

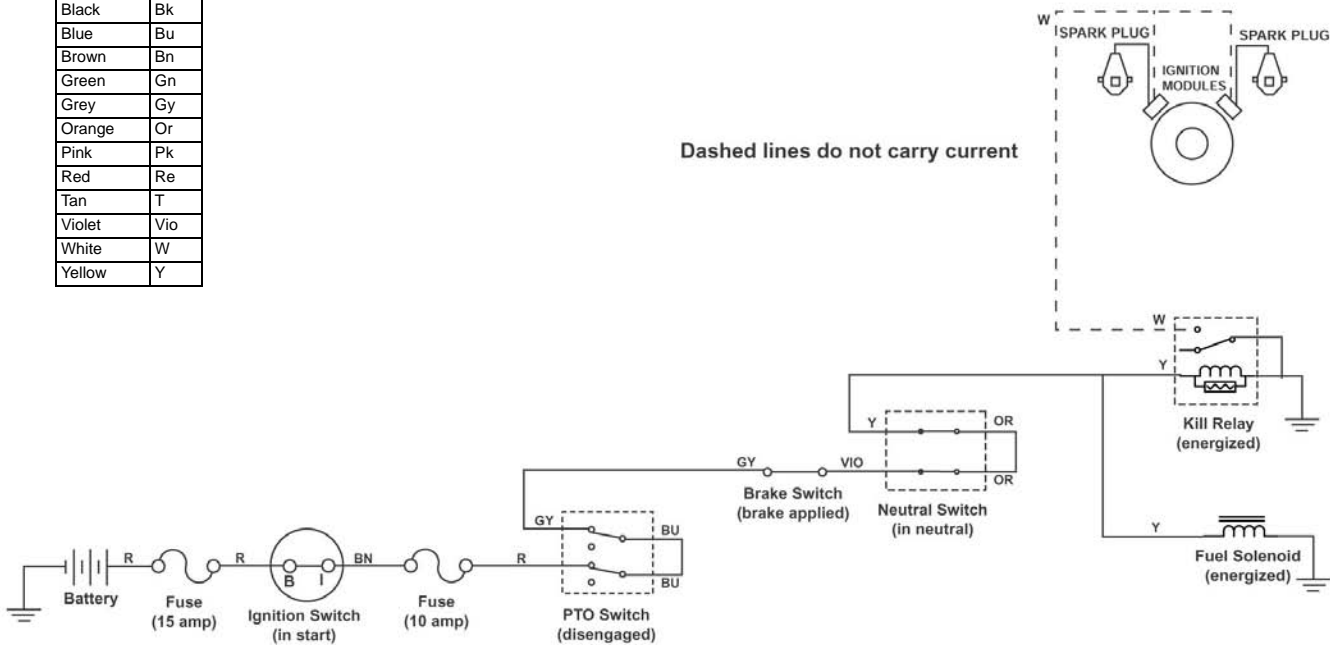

**Spark Circuit**  
(ignition switch in "run")

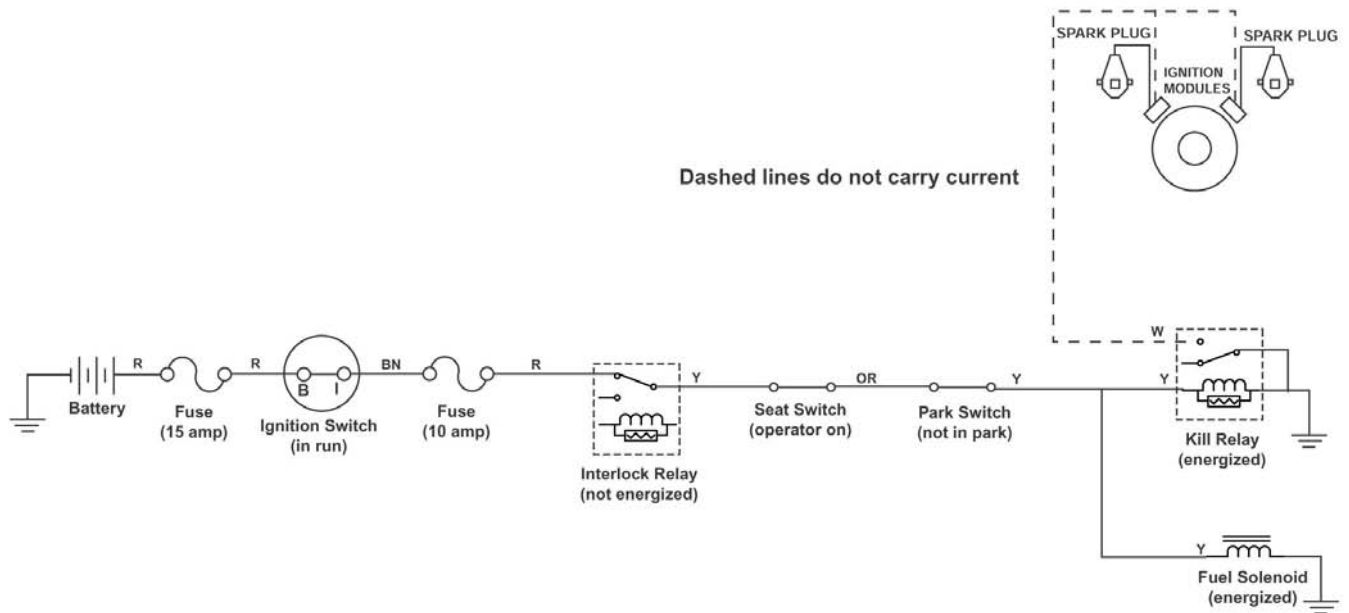

Legend	
Black	Bk
Blue	Bu
Brown	Bn
Green	Gn
Grey	Gy
Orange	Or
Pink	Pk
Red	Re
Tan	T
Violet	Vio
White	W
Yellow	Y

**Reverse Operating System Circuit**

(PTO "off", in forward)

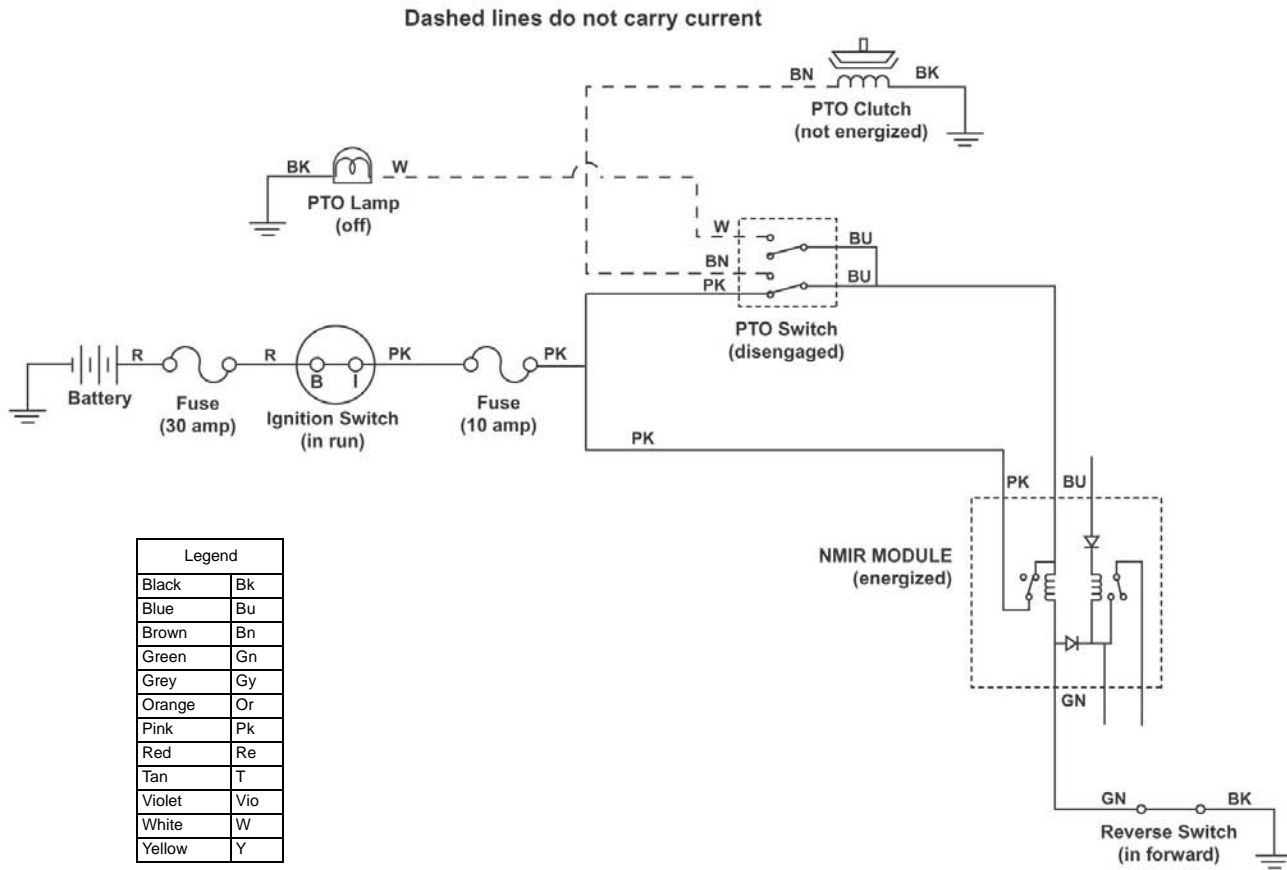

**Circuits**

**Reverse Operating System Circuit**  
(PTO "on", in forward)

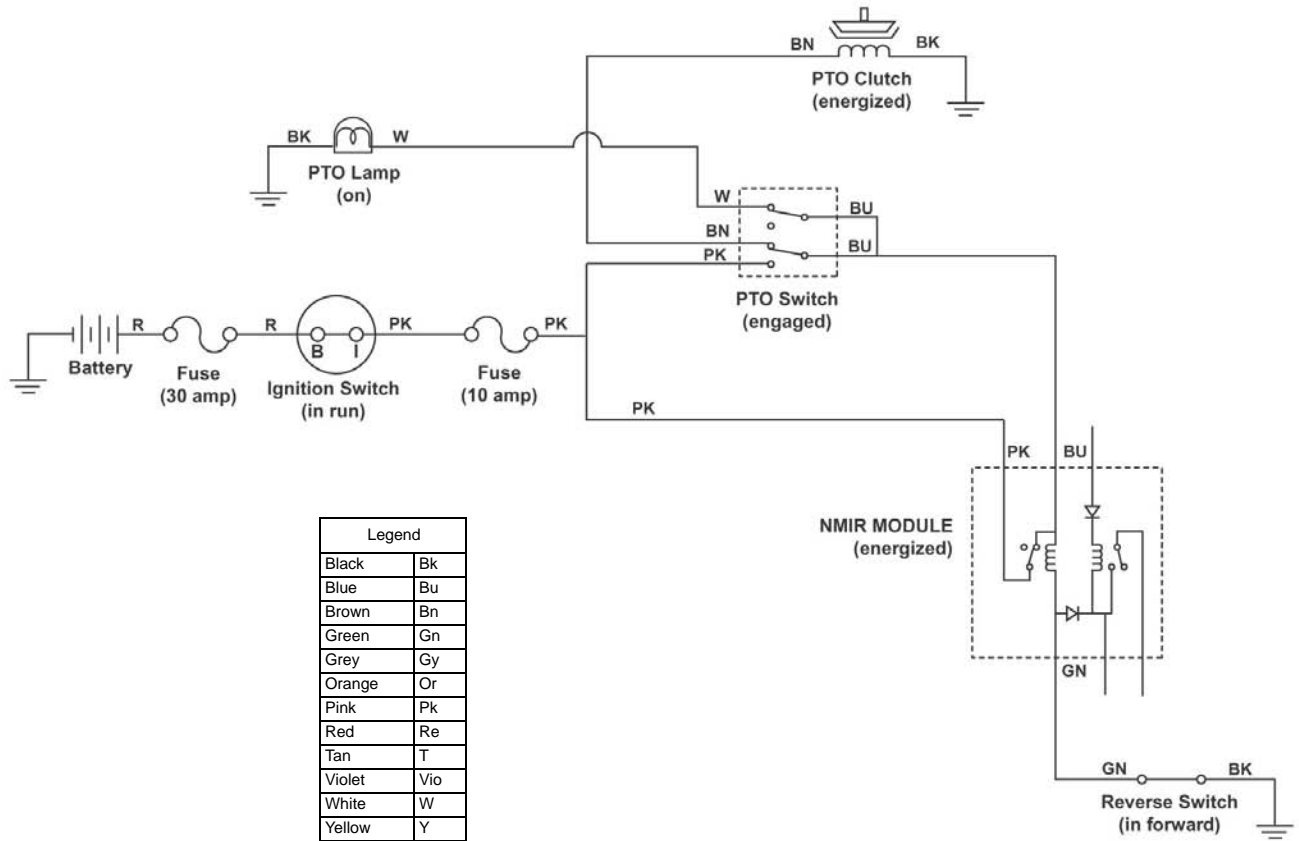

Legend	
Black	Bk
Blue	Bu
Brown	Bn
Green	Gn
Grey	Gy
Orange	Or
Pink	Pk
Red	Re
Tan	T
Violet	Vio
White	W
Yellow	Y

## Reverse Operating System Circuit

(PTO "on", in reverse)

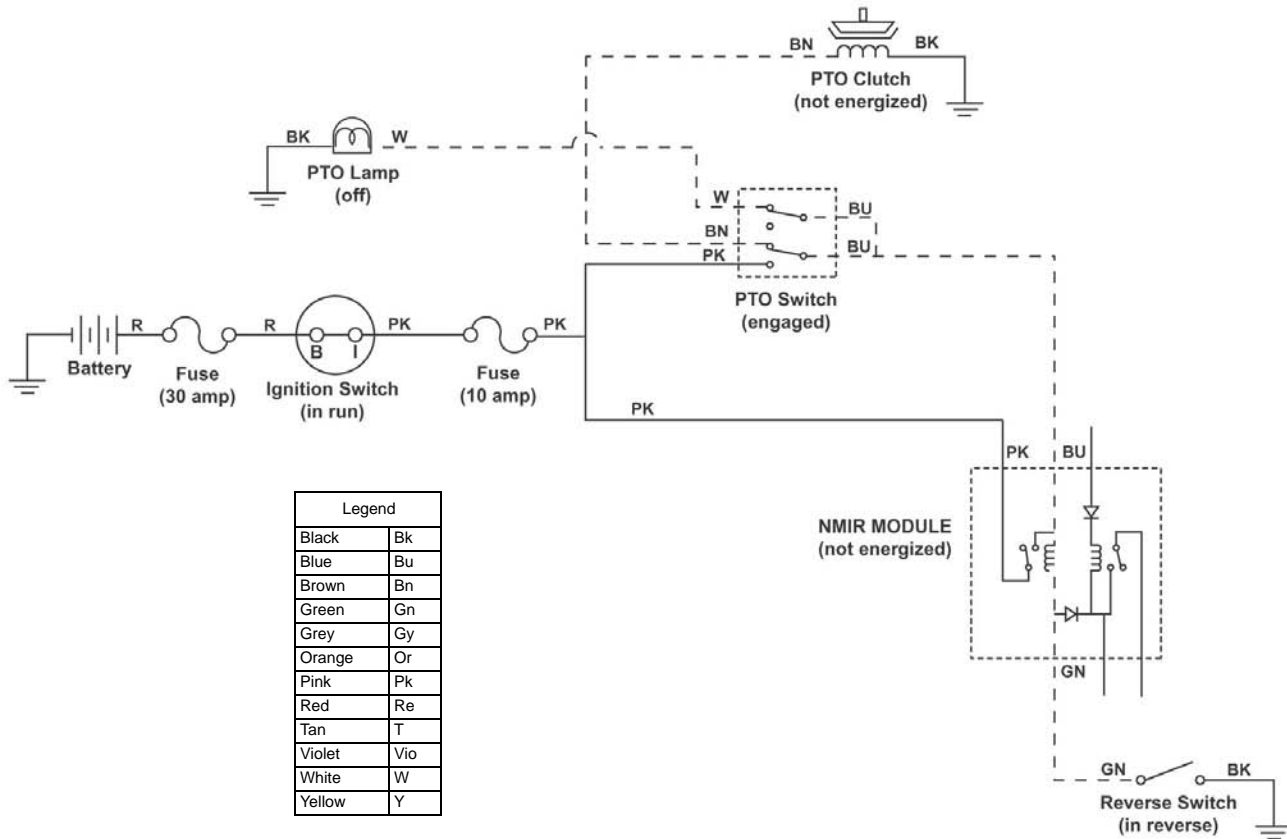

**Reverse Operating System Circuit**  
*(Override key switch "activated")*

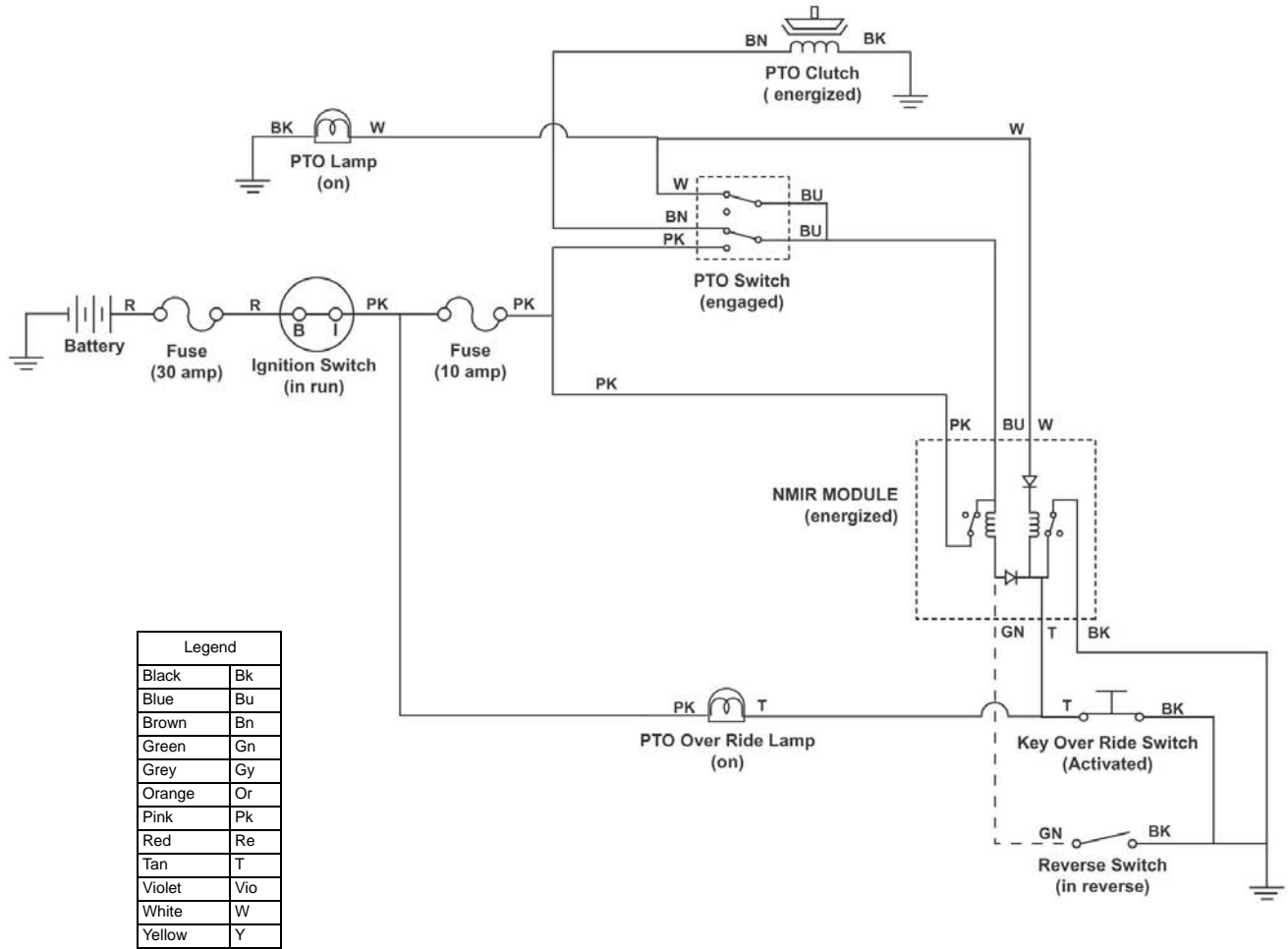

**Circuits**

**Reverse Operating System Circuit**

(PTO "on", in reverse, override mode)

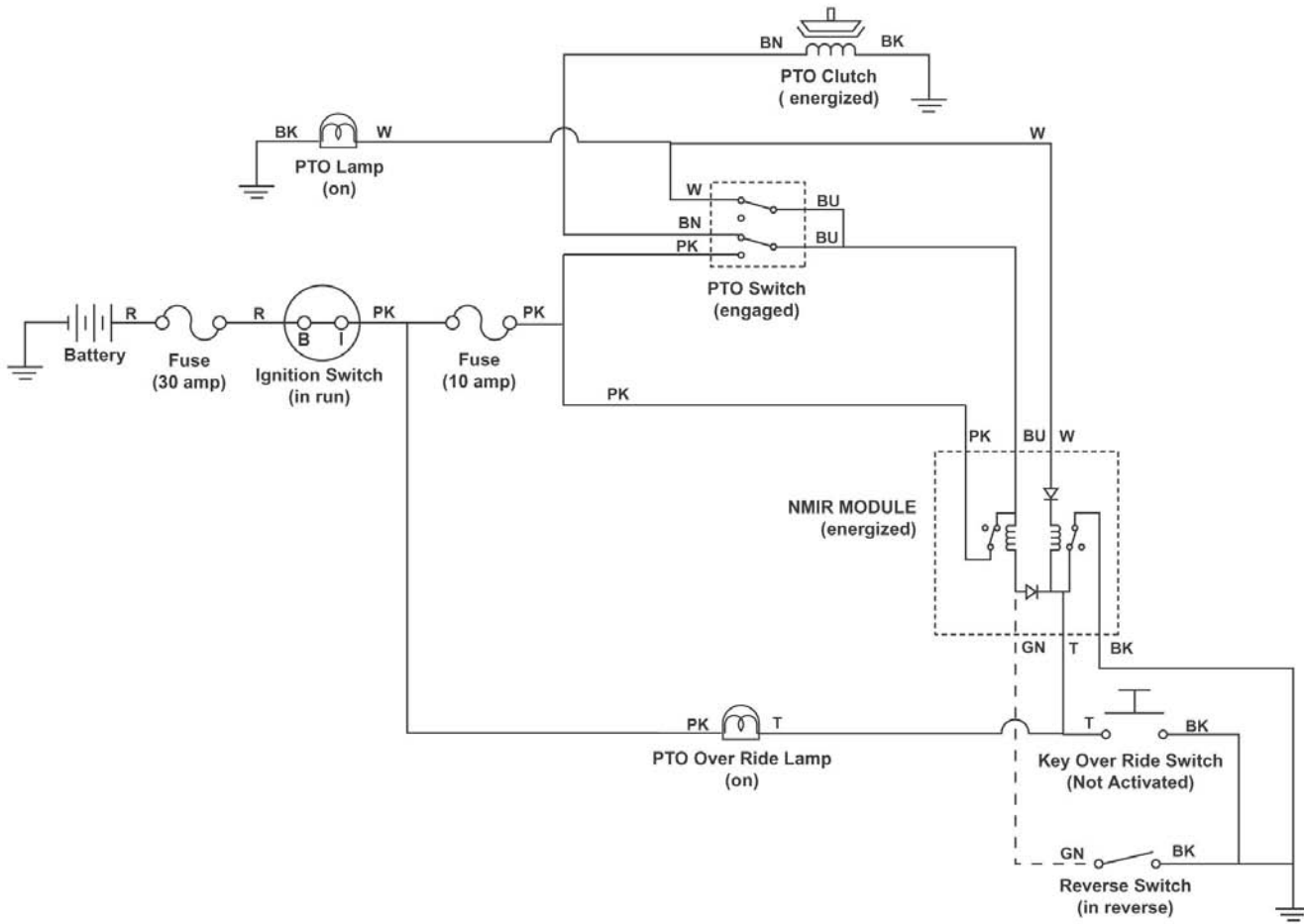

**Charging Circuit**

(ignition switch in "run")

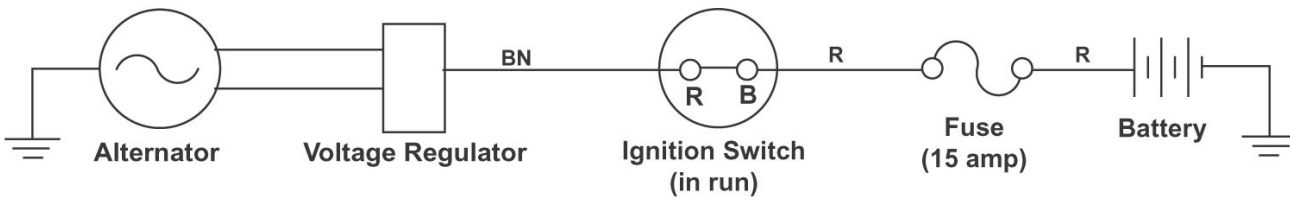

Legend	
Black	Bk
Blue	Bu
Brown	Bn
Green	Gn
Grey	Gy
Orange	Or
Pink	Pk
Red	Re
Tan	T
Violet	Vio
White	W
Yellow	Y



**Light Circuit**

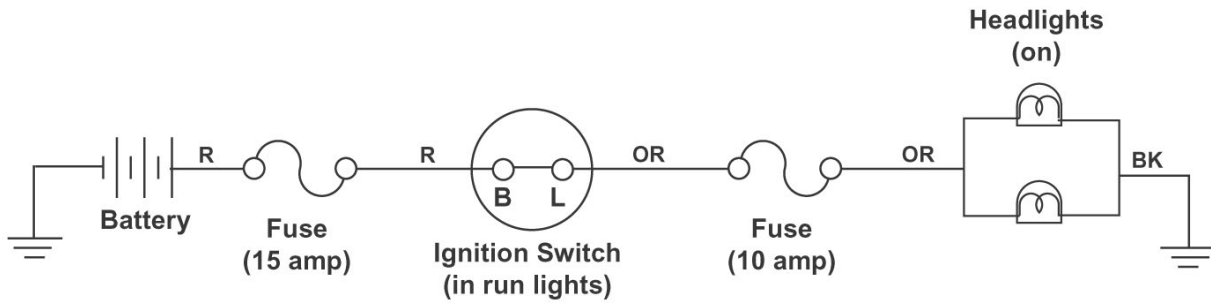

**Hourmeter Circuit**

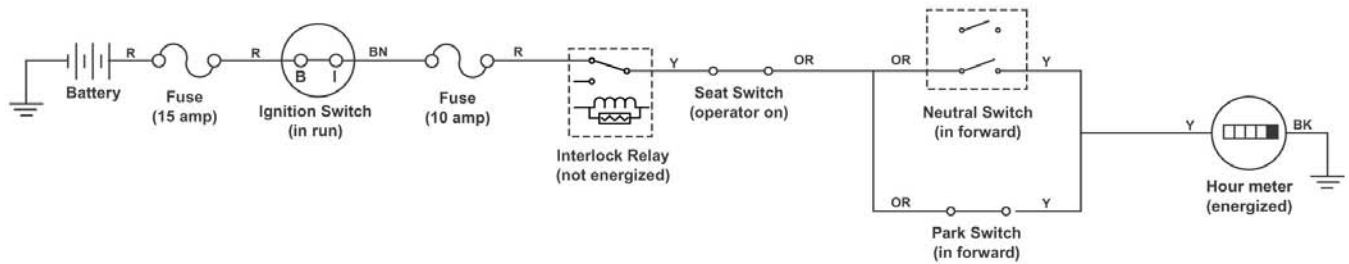

**Bag Full Circuit**

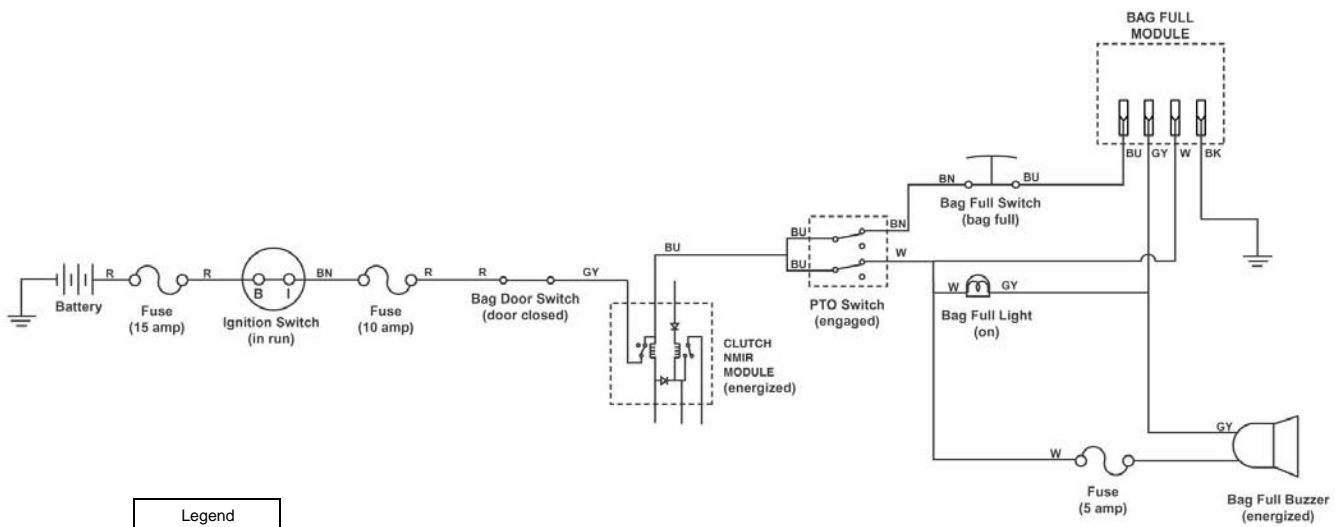

Legend	
Black	Bk
Blue	Bu
Brown	Bn
Green	Gn
Grey	Gy
Orange	Or
Pink	Pk
Red	Re
Tan	T
Violet	Vio
White	W
Yellow	Y

## Cruise Control Circuit (ignition switch in "run")

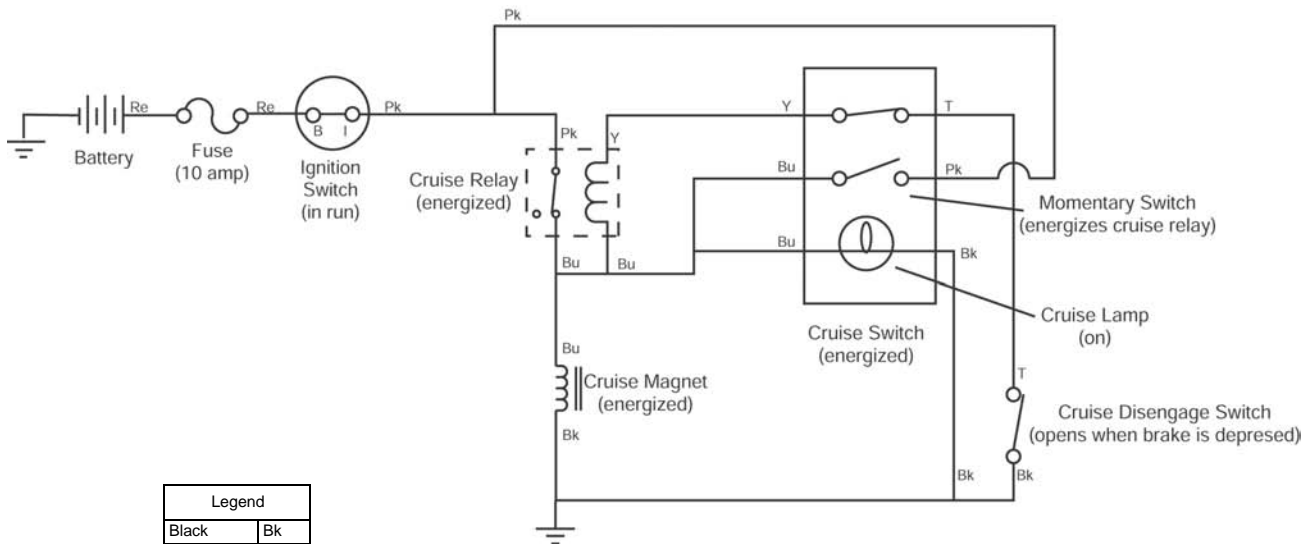

Legend	
Black	Bk
Blue	Bu
Brown	Bn
Green	Gn
Grey	Cy
Orange	Or
Pink	Pk
Red	Re
Tan	T
Violet	Vio
White	W
Yellow	Y