



MODEL NO. 41355 & 41356

OPERATOR'S
MANUAL

ENCLOSED BOOM

for the MULTI-PRO® 1100 VEHICLE

To assure maximum safety, optimum performance, and to gain knowledge of the product, it is essential that you or any other operator of this equipment read and understand the contents of this manual before the vehicle engine is ever started. Pay particular attention to the SAFETY INSTRUCTIONS highlighted by the triangular safety alert symbol.

 The safety alert symbol means CAUTION, WARNING, or DANGER — personal safety instruction. Failure to comply with the instruction may result in personal injury.

FOREWORD

You have purchased a product from the industry leader in maintenance excellence. Its future performance and dependability are of prime importance. TORO is also concerned about future use of the product and of safety to the user. Therefore, this manual must be read by you and those involved with the ENCLOSED BOOM to assure that safety, proper set-up, operation and maintenance procedures are followed at all times. The major sections of the manual are:

1. SAFETY INSTRUCTIONS
2. OPERATING INSTRUCTIONS
3. BEFORE SPRAYING
4. MAINTENANCE AND STORAGE

Safety, mechanical and some general information in this manual are emphasized. DANGER, WARNING and CAUTION identify safety messages. Whenever the triangular safety symbol appears, it is followed by a safety message that must be read and understood. For more details concerning safety, read the Safety Instructions on this page and page 2.

IMPORTANT identifies special mechanical information and NOTE identifies general information worthy of special attention. These instructions are provided as a guide for the safe operation and maintenance of this equipment. However, the operator's personal safety, as well as the persons in the work area, will depend on the careful actions and good judgement of the operator. To reduce the potential for injury or death, comply with the following safety instructions.

SAFETY INSTRUCTIONS

Keep this Operator's Manual in the plastic tube behind the operator seat.

It is very important that all persons operating this equipment have easy access to these instructions at all times!

Carefully read and follow the "Set-up" Instructions that are provided with this equipment and the Safety Instructions in the MULTI-PRO® Operators Manual and Spray System Operators Manual.

BEFORE OPERATING:

1. Operate this machine only after reading and understanding the contents of this manual. A replacement manual is available by sending complete model and serial number to:

Hahn Equipment Co., A subsidiary of The Toro Company, 1625 N. Garvin, Evansville, IN 47711

2. Learn how to operate the Sprayer and how to use the controls properly. DO NOT let anyone operate this equipment without first receiving thorough instructions.

SAFETY INSTRUCTIONS

3. Keep all shields, safety devices and decals in place. If a shield, safety device or decal is malfunctioning, illegible or damaged, repair or replace it before operating the machine.
4. Chemicals can injure persons, animals, plants, soils or other property. To eliminate environmental damage and personal injury:
 - A. Select the proper chemical for the job.
 - B. Follow manufacturer's instructions on chemical container labels. Apply and handle chemicals as recommended.
 - C. Handle and apply chemicals with care. Wear goggles and other necessary protective equipment. Handle chemicals in well ventilated areas. Never smoke while handling chemicals.
 - D. Properly dispose of chemical container and unused chemicals.
5. Drive the Vehicle slowly.

WHILE OPERATING:

1. **DO NOT OVERLOAD THE VEHICLE.** Failure to position loads carefully can result in their shifting or tipping over. Distribute loads evenly, keeping them as low as possible to prevent them from becoming too top-heavy.
2. Make certain everyone is clear of the machine before starting the engine to move the vehicle or to engage the sprayer pump drive.
3. This attachment adds extra height to the vehicle when the booms are in the raised position. Drive the vehicle safely:
 - A. Always SLOW the vehicle when approaching and while making a turn.
 - B. Always SLOW the Vehicle when driving in unfamiliar areas or over rough terrain.
 - C. Always SLOW the Vehicle when changing direction of travel or preparing to stop.
 - D. When turning or driving on slopes, always SLOW the Vehicle, then turn the Vehicle to prevent loss of control and possible upset.
 - E. **DO NOT** make sudden or sharp turns. **DO NOT** suddenly change direction of travel on an incline, ramp, grade, slope or similar surface.

- F. Always adjust the vehicle speed to allow for existing conditions such as wet, slick surfaces, low visibility, etc.
 - G. Be especially careful when driving a heavily loaded vehicle down an incline or slope. Drive the vehicle **UP** and **DOWN** the face of the slopes, inclines or grades. whenever possible. **DO NOT DRIVE** across the face if at all possible. There is a risk of upsetting the vehicle, which can result in serious injury or death.
4. Before backing up, look to the rear and assure no one is behind. Back up slowly.
 5. Watch out for traffic when near or crossing roads. Always yield the right of way to pedestrians and other vehicles.
 6. If equipment begins to vibrate abnormally, stop immediately. Shut off the vehicle engine and disengage all power. Repair all damage before commencing operation.
 7. Before servicing or making any adjustments to the Sprayer:
 - A. Stop the vehicle and set the parking brake.
 - B. Shut off the vehicle's engine and remove key from ignition.
 - C. Disengage all power and wait until all moving parts have stopped.
 - D. In order to avoid electric shock, inspect the area overhead for wires before raising booms.
 - E. Always use caution while operating the booms near low clearance areas.

8. Keep all nuts, bolts and other fasteners tightened securely. Replace any shields removed during servicing or adjustments.
9. To assure optimum performance and continued safety of this product, always use genuine TORO replacement parts and accessories. Replacement parts and accessories made by other manufacturers may affect the product's operation, performance or durability. Such use could also void the warranty of The Toro Company.

SAFETY AND INSTRUCTION DECALS

**ELECTRIC
BRAKE
CONTROL**



! WARNING

- BRAKE FAILURE CAN OCCUR IF THE BRAKES ARE NOT TESTED AND SERVICED REGULARLY TO ENSURE PROPER OPERATION.
- BRAKE FAILURE CAN CAUSE LOSS OF CONTROL AND RESULT IN SERIOUS INJURY OR DEATH.
- BOTH OF THE INDICATOR LAMPS MUST BE LIT WHEN THE BRAKE PEDAL IS DEPRESSED. IF ONE OR BOTH LAMPS DOES NOT LIGHT THE BRAKES SHOULD BE SERVICED IMMEDIATELY.
- THE AUXILIARY ELECTRIC BRAKES ARE NOT SELF-ADJUSTING AND SHOULD BE SERVICED EVERY 40 HOURS OF OPERATION.
- REFER TO OPERATORS MANUAL FOR SERVICING INFORMATION.

94-8727

Part No. 94-8727
Located on the Electric Brake Control.

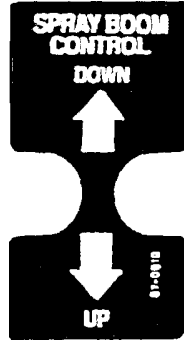

Part No. 87-0610
Located on the Top Panel - L.H.
to the left of the seat.

! CAUTION

IMPROPER LIFTING PROCEDURE WHEN FORWARD FOLDING THE BOOM EXTENSION COULD RESULT IN PERSONAL INJURY.

FOLLOW THE FORWARD FOLD INSTRUCTIONS DECAL LOCATED NEAR THE END OF THE BOOM EXTENSION.

ALSO READ AND UNDERSTAND THE INSTRUCTIONS IN OPERATORS MANUAL.

94-8703

Part No. 94-8703 Located on Boom Extension Hoods



! WARNING

**PINCH
POINT**

94-8701

Part No. 94-8701 Located on Center Section Ends and on Boom Extension Hoods near Actuator Link.

FORWARD FOLD INSTRUCTIONS.
NOTE: ACTUATOR MUST BE FULLY EXTENDED TO FORWARD FOLD EXTENSION BOOM

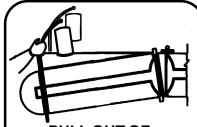

PULL OUT OF
BREAKAWAY LATCH



ROTATE BACK TO
STOP



STAND UP HOLDING
BOOM AT CHEST
HEIGHT

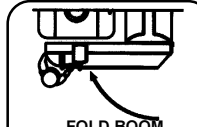

FOLD BOOM
PARALLEL TO
SPRAYER



INSERT RED PIN INTO
RED RECEPTACLE AND
FASTEN SAFETY LOCK.

94-8702

Part No. 94-8702 Located on Boom Extension curved Castor Wheel Mount

OPERATING INSTRUCTIONS

OPERATION

BOOM EXTENSION BREAKAWAY:

1. The breakaway latch is spring loaded to provide the required tension to keep the extension rigid until severe impact dislodges it.
2. If the boom extension releases too easily the tension can be increased by tightening the nut. See FIG. 1

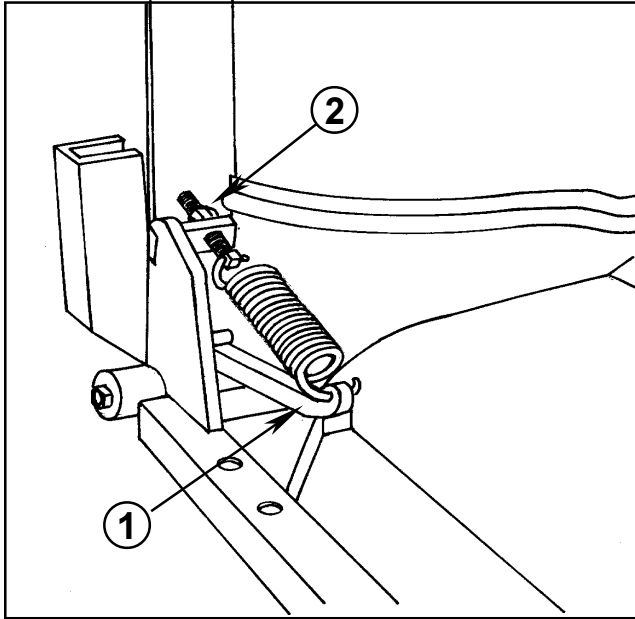

FIG 1.

1. Breakaway Latch 2. Tension Adjuster

TRANSPORTING BOOM IN VERTICAL POSITION:

1. Use the Up/Down switches to raise or lower the right or left booms.



CAUTION

- Improper Boom Extension lifting or lowering procedure could cause personal injury or death to the operator or a bystander.
- When lifting the Boom Extensions, always be aware of your surroundings. Do NOT operate near bystanders or other equipment. Be aware of overhead power lines which could cause electrical shock.
- On slopes the Boom Extensions should only be lowered with the vehicle facing up or down the slope
- Do not attempt to lower Boom Extensions on a slope with the Enclosed Boom oriented parallel to slope (vehicle perpendicular) for they can drop suddenly.

BOOM EXTENSION FORWARD FOLD:



CAUTION

- Use proper lifting procedures when lifting the Extension Boom into the forward fold position.
- Failure to follow proper lifting procedures could result in personal injury.
- Follow the Forward Fold Instructions Decal located near the end of the Boom Extension.
- Also read and understand the instructions in the OPERATORS MANUAL.



CAUTION

- Chemical residue may be on the Boom Extension.
- Chemicals are hazardous and can cause personal injury.
- Wear appropriate safety equipment when forward folding Boom Extension.

NOTE: The actuators must be fully extended for the booms to fold forward.

1. Stand at the end of the boom facing the center of the machine. Grasp the Castor Arm and give a pull towards the rear. This will release the breakaway.
2. Grasp the Castor Arm and lift to rotate back to stop.
3. Use your other hand to grasp the bottom of the shroud and lift the boom to chest height.
4. Walk with the boom towards the sprayer. Insert the transport pin into the receiver. Be sure to secure the safety clip to the forward loop. See FIG. 2.

⚠ WARNING

- Failure to attach the Safety Clip to the Safety Clip Anchor while transporting the Extension Booms in forward fold could allow the Boom Extension transport pin to come out of the pin receiver and the Boom Extension to be unsecured.
- An unsecured Boom Extension could cause personal injury or death to a bystander or other machine operator.
- Ensure that the Safety Clip is attached to the Safety Clip Anchor.

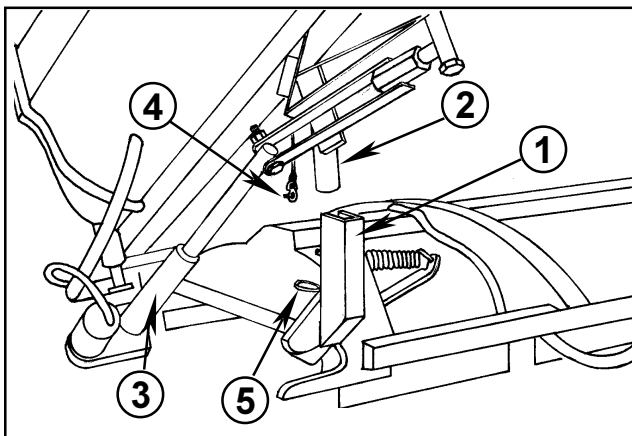

FIG 2.

- | | |
|------------------|-----------------------|
| 1. Pin Receiver | 4. Safety Clip |
| 2. Transport Pin | 5. Safety Clip Anchor |
| 3. Actuator | |

NOTE: A pictorial Forward Fold instruction Decal is located on the Boom Extension Castor Arm Mount.

FLOW MONITOR:

1. Each boom section has a flow monitor mounted in the operator's view. The monitor has four sight tubes; each tube contains a weighted ball that floats when there is flow to the corresponding nozzle.
2. When there is flow, all the floating balls should be at the same level. If a ball is lower than the others, this indicates a clogged spray nozzle tip. See FIG. 3.

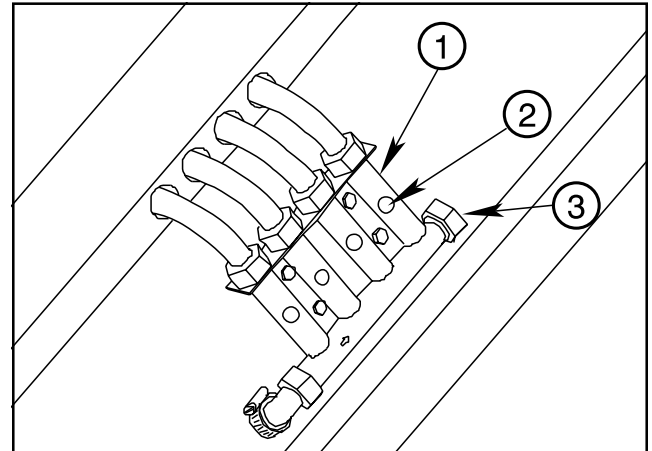

FIG 3.

- | | |
|-------------------------|---------------|
| 1. Flow Monitor | 3. Swivel Nut |
| 2. Stainless Steel Ball | |

3. The center boom section monitor contains only three floating balls and one sight tube is blocked off that is not in use.

4. If all the balls cannot be made to come up to the same level, check the flow in the lines to see if the flow is equal in all lines.

IMPORTANT: Freezing temperatures will damage the monitors if the water is not drained completely!

5. To drain the Flow Monitor remove the Swivel Nut on the capped end of the Flow Monitor.

ELECTRIC BRAKE OPERATION FOR MULTIPRO® 1100:

⚠ WARNING

- Brake failure can occur if the brakes are not tested and serviced regularly to ensure proper operation.
- Brake failure can cause loss of control and result in serious injury or death.
- Both of the indicator lamps must be lit when the brake pedal is depressed. If one or both lamps does not light the brakes should be serviced immediately.

1. The electric brakes are operational when both the left and right indicator lights are illuminated when the brake pedal is depressed. See FIG. 4.

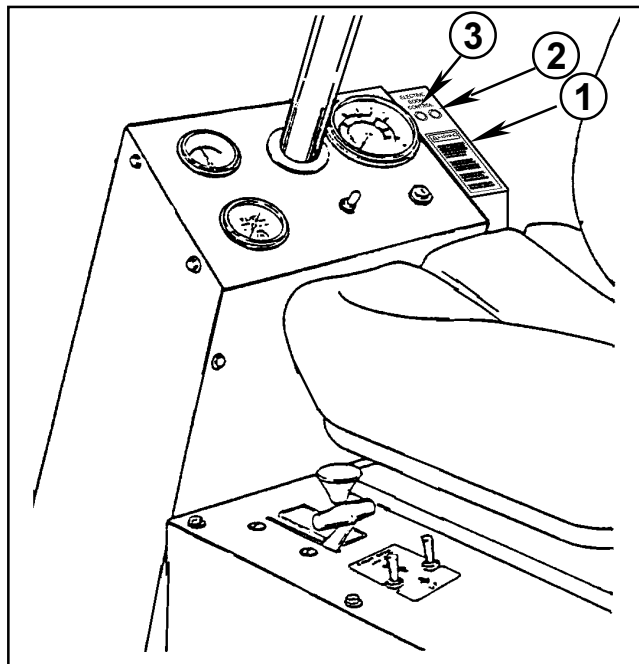

FIG. 4.

- 1. Electric Brake Controller
- 2. Right Brake Indicator Light
- 3. Left Brake Indicator Light

MAINTENANCE

BRAKE ADJUSTMENT:



WARNING

- Brake failure can occur if the brakes are not tested and serviced regularly to ensure proper operation.
- Brake failure can cause loss of control and result in serious injury or death.
- The Auxiliary Electric Brakes are not self-adjusting and should be serviced every 40 hours of operation.
- Refer to OPERATORS MANUAL for Brake Test and Adjustment Procedures.

To adjust the electric brakes, proceed as follows:

1. Remove the Access Slot Plug and use a jack stand, with the capacity necessary to lift the Vehicle to raise the tire clear of the ground surface.
2. Use a brake tool inserted through the slot in the drum to turn the adjusting star wheel, to expand the brake shoes within the drum. See FIG 5.

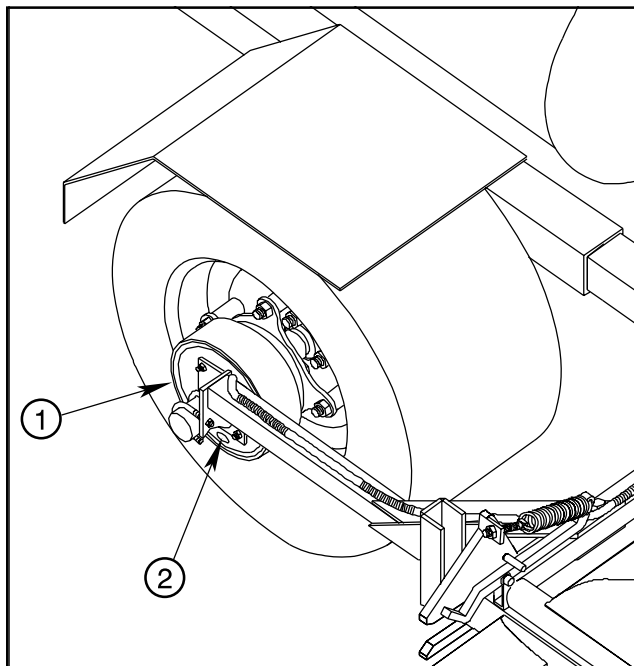

FIG. 5

- 1. Brake Drum
- 2. Access Slot

3. Engage one end of the tool in the star wheel teeth and pry **up** to tighten the right hand brake shoe. Pry **down** to tighten the left hand brake shoe.

4. Turn the adjusting screw until a heavy drag is felt while rotating the drum. Then back off the adjusting screw until the brake is just free of drag. Replace the Access Slot Plug.

BRAKE TEST PROCEDURE:

1. After every 40 hours of operation a brake operational test should be performed to confirm that the brakes are functioning properly.
2. Brake operation can be tested by depressing the brake pedal 1/8" - 1/4". Both lights on the Electric Brake Controller should be lit and the brakes should engage.
3. If the Brakes do not engage properly the Brake Switch can be adjusted by loosening the hex hd screws on the Brake Switch Mounting Bracket and rotating the Bracket. Re-tighten the screws after the Switch is correctly positioned.

BOOM EXTENSION ADJUSTMENT:

After every 200 operating hours, or annually, check movement of Extension Boom while in vertical transport position.

IMPORTANT: The Electric Boom Extension Lifts must be properly adjusted to operate correctly. Improper adjustment could damage the Boom.



CAUTION

- The adjustment of the Electric Boom Extension Lifts requires that the Actuator be separated from the Actuator Adjustment Link which leaves the Boom Extension unsupported.
- An unsupported Boom Extension could fall and cause personal injury or death.
- Use additional support for the Boom Extension when adjusting the Electric Boom Extension Actuator.
- It is recommended that the Boom Extension Electric Lift adjustments be done with two people.

1. Use the Up/Down switches to raise the Boom Extension to the upright position until the Stop on the front corner of the Boom Extension just makes contact with the contact pad on the Center Boom.

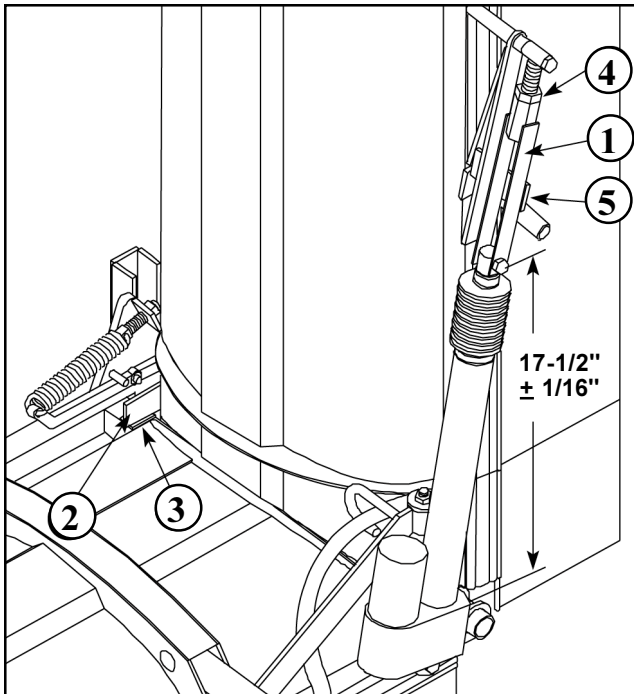

FIG 6

- | | |
|-----------------------------|-----------------------|
| 1. Actuator Adjustment Link | 4. Jam Nut |
| 2. Stop | 5. Actuator Link Stop |
| 3. Contact Pad | |

2. Measure the length of the Actuator. It should measure 17-1/2" \pm 1/16" from the face of the Actuator Front Housing to the center of the cap screw. (FIG. 6)

3. If the measurement is incorrect, remove the hex hd screw that attaches the Actuator Link to the Actuator, loosen the Jam Nut and rotate the Actuator

Link to change the length to the specification. Replace the hex hd screw and nut ensuring that the link can pivot freely. Re-tighten the Jam Nut, ensuring that the Actuator Link rests squarely on the Actuator Link Stop in the raised position.

NOTE: If the Actuator has more than the above specification this will bend the frame of the Extension Boom when the Actuator is fully contracted. Less than specification will cause excessive movement during vertical transport.

4. Re-torque the wing retainer lock nuts to 25 ft. lbs.

WHEEL AND BRAKE NUT TIGHTENING:

IMPORTANT: Check and maintain the Wheel Mount nuts at the specified torque found in this manual and the MULTI-PRO® 1100 OPERATORS MANUAL.



CAUTION

- Wheel or Brake Mount failure could occur if proper nut torque is not maintained.
- Wheel or Brake Mount failure could result in serious injury or death.
- Torque nuts as per the specifications given in the OPERATORS MANUAL.

The Wheel and Mount nuts should be torqued to the following values:

- MULTI-PRO® 1100 Rear Wheel Nuts - 75 ft. lbs. (100 N-m)
- Retainer Bolt Nuts - Adaptor Plate (Left Wheel) - 90 ft. lbs. (120 N-m)
- Carriage Bolt Nuts - Adaptor Plate (Right Wheel) - 90 ft. lbs. (120 N-m)
- Electric Brake - Adaptor Plate Nuts - 90 ft. lbs. (120 N-m)

At the following intervals:

- When the Enclosed Boom is installed.
- After the first 10 hours of operation.
- Every 200 hours, or annually, thereafter.

HOSE CLAMPS:



CAUTION

- **Chemicals are hazardous and can cause personal injury!**
- **Securely tighten all sprayer hose clamp connections at regular intervals to prevent leaks and hose blow-offs while spraying system is in operation.**

1. Tighten Hose Clamps every 200 hours, or annually.

GENERAL MAINTENANCE:

DAILY: Grease fittings on Boom Mount, Castor Mounts and Castor Wheels.

STORAGE

FLUSH BOOM AFTER USE:

1. Flush the entire system with a solution that will chemically neutralize the liquid in the monitors. Mix according to manufacturers directions. This will dissolve most residue remaining in the monitor.

NOTE: The flow monitors will discolor if proper flushing procedures are not adhered to.

2. The flow monitor is susceptible to discoloration if exposed to direct sunlight for several years. To reduce the effect of sunlight, store the monitor indoors or cover when not in use.

IMPORTANT: Freezing temperatures will damage the monitors if the water is not drained completely. See **FLOW MONITOR Operating Instructions** for draining procedure.

NOTES:

NOTES:

BEFORE SPRAYING

IMPORTANT: The Enclosed Boom nozzle bar is fixed at 15" height and 20 inch spacing. Use only Flat Fan 110° tips to maintain proper calibration.

NOZZLE SELECTION

See the SPRAY NOZZLE SELECTION CHART to be sure that your spray nozzles have the capacity necessary to achieve the application rate selected.

To select the proper nozzle, you need to know:

1. Recommended chemical application rate in gallons per acre, gallons per 1000 sq. ft. or liters per hectare.
2. Average Vehicle speed in Miles per hour or kilometers per hour.
3. Nozzle spacing (20 inches or 50 centimeters.)

With this information you can calculate the volume per minute per nozzle, using the formulas below.

US FORMULA:

$$\text{G.P.M. (Per Nozzle)} = \frac{\text{G.P.A} \times \text{M.P.H.} \times 20 \text{ ins.}}{5940}$$

TU (Turf) FORMULA:

$$\text{G.P.M. (Per Nozzle)} = \frac{\text{G.P.K} \times \text{M.P.H.} \times 20 \text{ ins.}}{137}$$

SI (METRIC) FORMULA:

$$\text{lit/min (Per Nozzle)} = \frac{\text{lit/ha} \times \text{km/h} \times 50 \text{ cm}}{60,000}$$

Use G.P.M. (lit/min) and Pressure to select appropriate nozzle from chart on page 9.

EXAMPLE (US FORMULA)

Application Rate = 75 Gallons/Acre
Vehicle Speed = 4 M.P.H.
Nozzle Spacing = 20 inches

$$\frac{75 \text{ G.P.A.} \times 4 \text{ M.P.H.} \times 20}{5940} = 1.00 \text{ G.P.M. (per nozzle)}$$

With 1.00 G.P.M. and a pressure of 40 P.S.I. you would select Nozzle No. 94-8718

EXAMPLE (TU FORMULA)

Application Rate = 1.70 Gal./1000 sq. ft.
Vehicle Speed = 4 M.P.H.
Nozzle Spacing = 20 inches

$$\frac{1.70 \text{ G.P.K.} \times 4 \text{ M.P.H.} \times 20}{137} = 1.00 \text{ G.P.M. (per nozzle)}$$

EXAMPLE (SI FORMULA)

Application Rate = 907 lit/hectare
Vehicle Speed = 5 km/h
Nozzle Spacing = 50 cm

$$\frac{907 \text{ lit/ha} \times 5 \text{ km/h} \times 50}{60,000} = 3.78 \text{ lit/min. (per nozzle)}$$

With 3.78 G.P.M. and a pressure at 275 kPa you would select nozzle No. 94-8718

SYMBOL DEFINITIONS:

GPM	- Gallons per minute
lit/min	- Liters per minute
dl/min	- Deciliter per minute
PSI	- Pounds per square inch
kPa	- Kilopascal
GPA	- Gallons per acre
lit/ha	- Liters per hectare
ml/ha	- Milliliter per hectare
GPK	- Gallons per 1,000 sq. ft.
mm	- Millimeters
cm	- Centimeters
dm	- Decimeters
m	- Meter
MPH	- Miles per hour
km	- Kilometers
km/h	- Kilometers per hour
US	- Volume per ACRE
SI	- Volume per HECTARE
TU	- Volume per 1,000 sq. ft.

LIQUID CONVERSIONS:

U.S. Gallons x128 = Fluid Ounces
U.S. Gallons x 3.785 = Liters
U.S. Gallons x 0.83267 = Imperial Gallons
U.S. Gallons x 8.34 = Pounds (Water)

LENGTH:

1 millimeter (mm) = 0.039 inch
1 centimeter (cm) = 0.393 inch
1 meter (m) = 3.281 feet
1 kilometer (km) = 0.621 mile
1 inch = 25.4 millimeters; 2.54 centimeters
1 mile = 1.609 kilometers

PRESSURE:

1 psi = 6.89 kPa

AREA:

1 square meter = 10.764 sq. feet
1 hectare (ha) = 2.471 acres; 10,000 sq. meters
1 acre = 0.405 hectare; 43,560 sq. ft.
1 sq. mile = 640 acres; 258.9 hectares

SPRAY NOZZLE SELECTION CHART

TORO Part No.	Nozzle Number Color-Code	Pressure (PSIG)	Capacity 1-Nozzle (GPM)	APPLICATION RATES FOR NOZZLES 20" SPACING							
				GALLONS PER ACRE				GALLONS PER 1000 SQ. FT.			
				3 MPH	4 MPH	5 MPH	6 MPH	3 MPH	4 MPH	5 MPH	6 MPH
94-8714	XR11004VS 110° Red	20	.28	28	21	17	14	0.64	0.48	0.39	0.32
		30	.35	34	26	20	17	0.78	0.60	0.46	0.39
		40	.40	40	30	24	20	0.92	0.69	0.55	0.46
		50	.45	44	33	27	22	1.01	0.76	0.62	0.51
94-8715	XR11005VS 110° Brown	20	.36	35	26	21	17.5	0.80	0.60	0.48	0.40
		30	.44	42	32	26	21	0.96	0.73	0.60	0.48
		40	.50	50	37	30	25	1.15	0.85	0.69	0.57
		50	.56	56	42	33	28	1.29	0.96	0.76	0.64
94-8716	XR11006VS 110° Gray	20	.43	42	32	25	21	0.96	0.73	0.57	0.48
		30	.52	52	39	31	26	1.19	0.90	0.71	0.60
		40	.60	60	45	36	30	1.38	1.03	0.83	0.69
		50	.67	66	50	40	33	1.52	1.15	0.92	0.76
94-8717	XR11008VS 110° White	20	.57	56	42	34	28	1.29	0.96	0.78	0.64
		30	.70	68	51	41	34	1.56	1.17	0.94	0.78
		40	.80	80	59	48	40	1.84	1.35	1.10	0.92
		50	.90	88	66	53	44	2.02	1.52	1.22	1.01
94-8718	XR11010SS 110° Stainless	20	.71	70	53	42	35	1.61	1.22	0.96	0.80
		30	.87	86	64	51	43	1.97	1.47	1.17	0.99
		40	1.0	100	74	59	50	2.30	1.70	1.35	1.15
		50	1.1	110	83	66	55	2.53	1.91	1.52	1.26
94-8719	XR11015SS 110° Stainless	20	1.1	106	79	63	53	2.43	1.81	1.45	1.22
		30	1.3	128	96	77	64	2.94	2.20	1.77	1.47
		40	1.5	148	111	89	74	3.40	2.55	2.04	1.70
		50	1.7	166	125	100	83	3.81	2.87	2.30	1.91

TORO Part No.	Nozzle Number Color-Code	Pressure (kPa)	Capacity 1-Nozzle (L/min)	APPLICATION RATES FOR NOZZLES 50 cm SPACING			
				LITERS PER HECTAREE			
				5 km/h	6 km/h	8 km/h	10 km/h
94-8714	XR11004VS 110° Red	150	0.56	134	112	84	67
		200	0.64	155	129	97	77
		275	0.76	181	151	113	91
		350	0.85	205	171	128	102
94-8715	XR11005VS 110° Brown	150	1.40	335	279	209	167
		200	1.61	387	322	242	193
		275	1.89	453	378	283	227
		350	2.13	512	426	320	256
94-8716	XR11006VS 110° Gray	150	1.67	402	335	251	201
		200	1.93	464	387	290	232
		275	2.27	544	453	340	272
		350	2.56	614	512	384	307
94-8717	XR11008VS 110° White	150	2.23	536	447	335	268
		200	2.58	619	516	387	309
		275	3.02	726	605	453	363
		350	3.41	819	682	512	409
94-8718	XR11010SS 110° Stainless	150	2.79	670	558	419	335
		200	3.22	773	645	483	387
		275	3.78	907	756	567	453
		350	4.26	1023	853	640	512
94-8719	XR11015SS 110° Stainless	150	4.18	1008	840	630	504
		200	4.84	1176	980	735	588
		275	5.67	1368	1140	855	684
		350	6.40	1536	1280	960	768

NOTE: If drift control is the primary concern operate at lower pressures (25-30 psi) and use a larger nozzle size. This will result in a larger overall droplet size which is less likely to drift.

**The Toro Promise
A One Year Limited Warranty**

The Toro Company promises to repair your Model 41355 ENCLOSED BOOM for the MULTI PRO® 1100 Vehicle if defective in materials or workmanship. The following time periods from the date of purchase apply special warranty terms, on certain components, may be offered through The Toro Company by the component manufacturers:

Commercial Products.....1 Year

The cost of parts, labor and transportation are included.

If you feel your TORO Product is defective and wish to rely on The Toro Promise, the following procedure is recommended:

1. Contact your Authorized TORO Distributor or Commercial Dealer (the Yellow Pages of your telephone directory is a good reference source).
2. The TORO Distributor or Commercial Dealer will advise you on the arrangements that can be made to inspect and repair your product.
3. The TORO Distributor or Commercial Dealer will inspect the product and advise you whether the product is defective and, if so, make all repairs necessary to correct the defect without an extra charge to you.

If for any reason you are dissatisfied with the distributor's analysis of the defect or the service performed, you may contact us.

Write:

TORO Commercial Products Service Department
8111 Lyndale Avenue South
Bloomington, MN 55420-1196

The above remedy of product defects through repair by an Authorized TORO Distributor or Commercial Dealer is the purchaser's sole remedy for any defect.

THERE IS NO OTHER EXPRESS WARRANTY. ALL IMPLIED WARRANTIES OF MERCHANTABILITY AND FITNESS FOR USE ARE LIMITED TO THE DURATION OF THE EXPRESS WARRANTY.

Some states do not allow limitations on how long an implied warranty lasts, so the above limitation may not apply to you.

This Warranty applies only to parts or components which are defective and does not cover repairs necessary due to normal wear, misuse, accidents, or lack of proper maintenance. Regular, routine maintenance of the unit to keep it in proper operating condition is the responsibility of the owner.

All warranty repairs reimbursable under The Toro Promise must be performed by an Authorized Toro Commercial Dealer or Distributor using Toro approved replacement parts.

Repairs or attempted repairs by anyone other than an Authorized TORO Distributor or Commercial Dealer are not reimbursable under The TORO Promise. In addition, these unauthorized repair attempts may result in additional malfunctions, the correction of which is not covered by warranty.

THE TORO COMPANY IS NOT LIABLE FOR INDIRECT, INCIDENTAL OR CONSEQUENTIAL DAMAGES IN CONNECTION WITH THE USE OF THE PRODUCT INCLUDING ANY COST OR EXPENSE OF PROVIDING SUBSTITUTE EQUIPMENT OR SERVICE DURING PERIODS OF MALFUNCTION OR NON-USE.

Some states do not allow the exclusion of incidental or consequential damages, so the above exclusion may not apply to you.

This warranty gives you specific legal rights, and you may also have other rights which vary from state to state.

COUNTRIES OTHER THAN THE UNITED STATES OR CANADA

Customers who have purchased TORO products exported from the United States or Canada should contact their TORO Distributor (Dealer) to obtain guarantee policies for your country, province, or state. If for any reason you are dissatisfied with your Distributor's service or have difficulty obtaining guarantee information, contact the TORO importer. If all other remedies fail, you may contact us at The Toro Company.