



**Count on it.**

**Operator's Manual**

**8-Blade, 11-Blade, or 14-Blade  
EdgeSeries™ DPA Cutting Unit  
Greensmaster® 3150 or 3250-D Series  
Traction Unit**

Model No. 04652—Serial No. 408000000 and Up

Model No. 04654—Serial No. 408000000 and Up

Model No. 04656—Serial No. 408000000 and Up

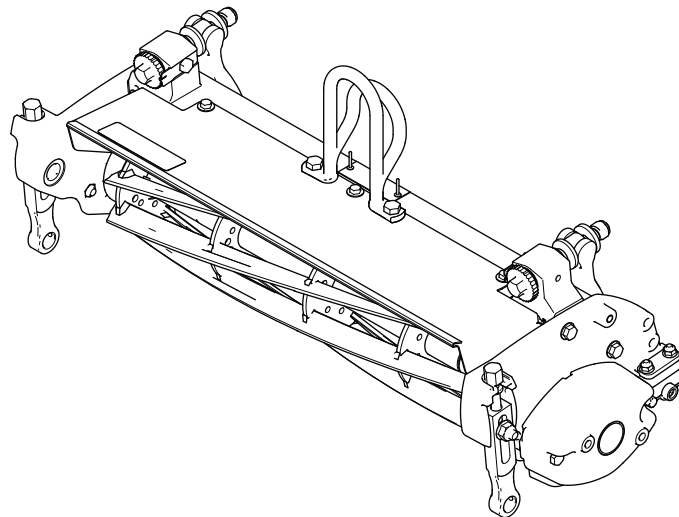

This product complies with all relevant European directives. For details, please see the Declaration of Incorporation (DOI) at the back of this publication.

# Introduction

This cutting unit is designed for cutting turf on greens and small fairways of golf courses. Using this product for purposes other than its intended use could prove dangerous to you and bystanders.

Read this information carefully to learn how to operate and maintain your product properly and to avoid injury and product damage. You are responsible for operating the product properly and safely.

Visit [www.Toro.com](http://www.Toro.com) for product safety and operation training materials, accessory information, help finding a dealer, or to register your product.

Whenever you need service, genuine the manufacturer parts, or additional information, contact an Authorized Service Dealer or the manufacturer Customer Service and have the model and serial numbers of your product ready. **Figure 1** identifies the location of the model and serial numbers on the product. Write the numbers in the space provided.

**Important:** With your mobile device, you can scan the QR code on the serial number plate (if equipped) to access warranty, parts, and other product information.

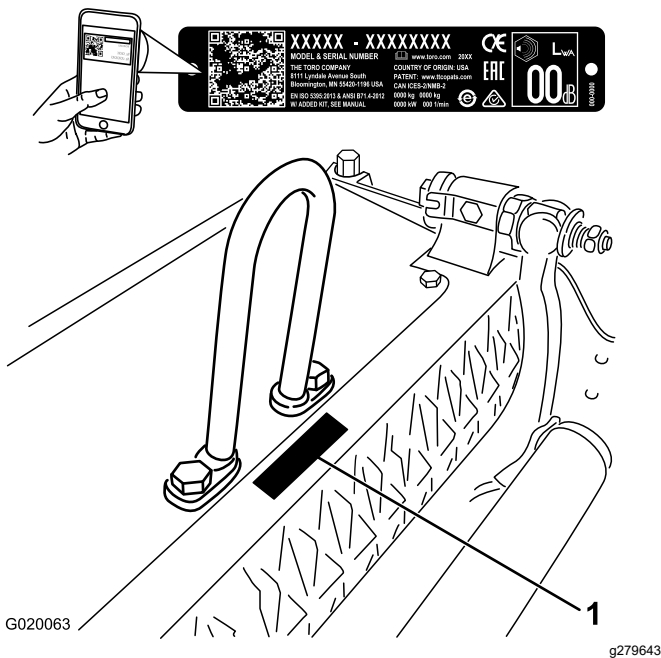

**Figure 1**

1. Location of the model and serial numbers

Model No. _____
Serial No. _____

This manual identifies potential hazards and has safety messages identified by the safety-alert symbol (**Figure 2**), which signals a hazard that may cause serious injury or death if you do not follow the recommended precautions.



**Figure 2**  
Safety-alert symbol

g000502

This manual uses 2 words to highlight information. **Important** calls attention to special mechanical information and **Note** emphasizes general information worthy of special attention.

# Contents

Safety .....	3
General Safety .....	3
Cutting Unit Safety .....	3
Blade Safety .....	3
Safety and Instructional Decals .....	4
Setup .....	5
1 Installing the Front Roller .....	5
2 Installing the Ball Studs .....	5
3 Installing the Hoop Link, Offset Link, or Chain Link .....	6
4 Repositioning the Counter Weights .....	7
5 Adjusting the Cutting Unit .....	7
Product Overview .....	8
Specifications .....	8
Attachments/Accessories .....	8
Operation .....	8
Adjusting the Cutting Unit .....	8
Adjusting the Height of Cut .....	11
Height-of-Cut and Bedknife Selection Charts .....	12
Maintenance .....	13
Supporting the Cutting Unit .....	13
Servicing the Bedbar .....	13
Bedknife Specifications .....	15
Reel Specifications .....	17
Backlapping the Cutting Unit .....	17

# Safety

## General Safety

This product is capable of amputating hands and feet. Always follow all safety instructions to avoid serious personal injury.

- Read and understand the contents of this *Operator's Manual* before starting the machine.
- Use your full attention while operating the machine. Do not engage in any activity that causes distractions; otherwise, injury or property damage may occur.
- Do not put your hands or feet near moving components of the machine.
- Do not operate the machine without all guards and other safety protective devices in place and functioning properly on the machine.
- Keep clear of any discharge opening.
- Keep bystanders and children out of the operating area. Never allow children to operate the machine.
- Before you leave the operator's position, do the following:
  - Park the machine on a level surface.
  - Lower the cutting unit(s).
  - Disengage the drives.
  - Engage the parking brake (if equipped).
  - Shut off the engine and remove the key (if equipped).
  - Wait for all movement to stop.

Improperly using or maintaining this machine can result in injury. To reduce the potential for injury, comply with these safety instructions and always pay attention to the safety-alert symbol▲, which means Caution, Warning, or Danger—personal safety instruction. Failure to comply with these instructions may result in personal injury or death.

## Cutting Unit Safety

- The cutting unit is only a complete machine when installed on a traction unit. Read the traction unit *Operator's Manual* carefully for complete instructions on the safe use of the machine.
- Stop the machine, remove the key (if equipped), and wait for all movement to stop before inspecting the attachment after striking an object or if there is an abnormal vibration in the machine. Make all necessary repairs before resuming operation.
- Keep all parts in good working condition and all hardware tightened. Replace all worn or damaged decals.
- Use only accessories, attachments, and replacement parts approved by the manufacturer.

## Blade Safety

A worn or damaged blade can break, and a piece of the blade could be thrown toward you or bystanders, resulting in serious personal injury or death.

- Inspect the blade periodically for wear or damage.
- Use care when checking the blades. Wrap the blades or wear gloves, and use caution when servicing the blades. Only replace or sharpen the blades; never straighten or weld them.
- On multi-bladed machines, take care as rotating 1 blade can cause other blades to rotate.

# Safety and Instructional Decals



Safety decals and instructions are easily visible to the operator and are located near any area of potential danger. Replace any decal that is damaged or missing.

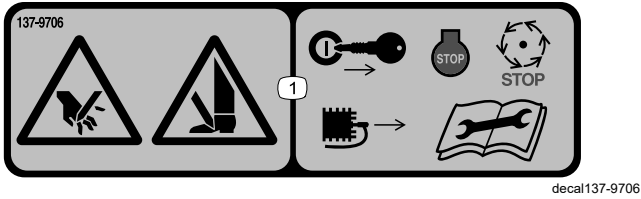

**137-9706**

1. Cutting hazard of the hand or foot—shut off the engine, remove the key or disconnect the spark plug, wait for all moving parts to stop, and read the *Operator's Manual* before performing maintenance.

# Setup

## Media and Additional Parts

Description	Qty.	Use
Ball stud	2	Mount this to the roller.
Operator's Manual	1	Read before installing and operating the cutting unit.

# 1

## Installing the Front Roller

### No Parts Required

### Procedure

The cutting unit is shipped without a front roller. Obtain a roller from your authorized Toro distributor and install it on the cutting unit, as follows:

1. Remove the plow bolt and flange locknut securing one of the height-of-cut arms to the cutting unit side plate (Figure 3).

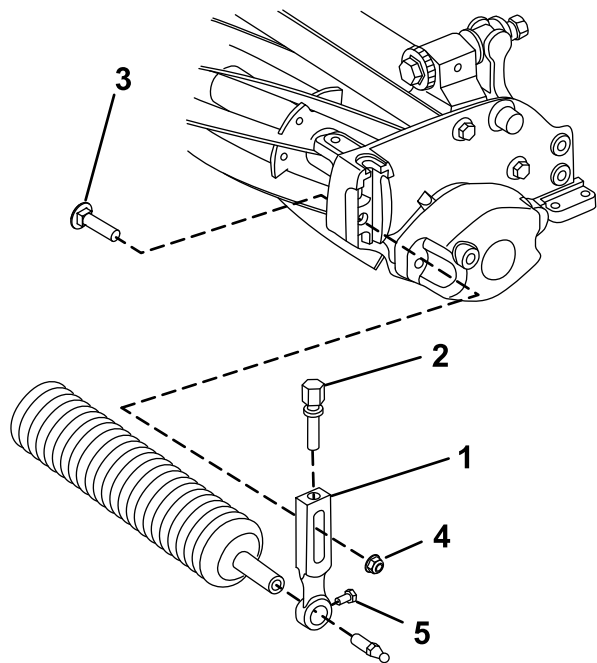

Figure 3

g278288

1. Height-of-cut arm
2. Adjusting screw
3. Plow bolt
4. Flange locknut
5. Roller-mounting screw

3. Slide the roller shaft into the height-of-cut arm on the opposite end of the cutting unit (Figure 3).
4. Slide the height-of-cut arm onto the roller shaft (Figure 3).
5. Loosely secure the roller to the cutting unit with the height-of-cut arm and fasteners previously removed (Figure 3).
6. Center the roller between the height-of-cut arms.
7. Tighten the roller-mounting screws (Figure 3).
8. Adjust to the desired height-of-cut and tighten the height-of-cut arm mounting fasteners.

# 2

## Installing the Ball Studs

### No Parts Required

### Procedure

Install a ball stud on each end of the front roller (Figure 4).

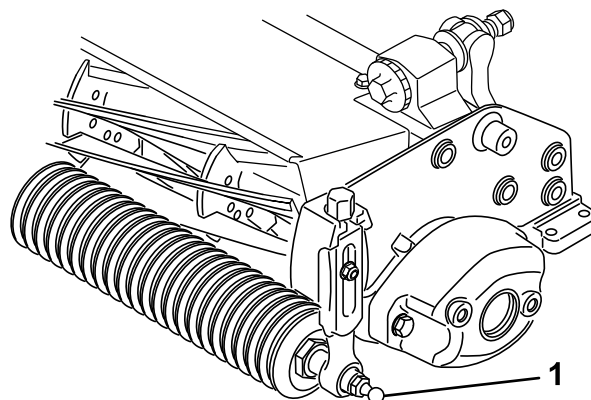

Figure 4

g279642

1. Ball stud

2. Loosen the roller-mounting screws in the height-of-cut arms (Figure 3).

# 3

## Installing the Hoop Link, Offset Link, or Chain Link

No Parts Required

### Procedure

For cutting units mounting on a traction unit with a serial number prior to 240000001, obtain and install the proper lift link as follows:

**Note:** The 2 bolts used to mount the lift link are shipped installed on the cutting unit.

- For Greensmaster 3120 and 3150 traction units, install the hoop link supplied with the traction unit.

Install the hoop link (Part No. 105-5740) to the top of the cutting unit with 2 bolts. Torque the bolts to 34 to 40 N·m (25 to 30 ft-lb) (Figure 5).

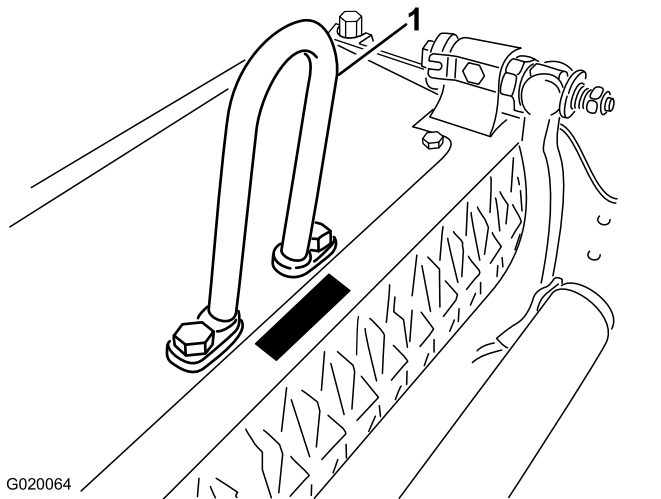

**Figure 5**

- Hoop link (Part No. 105-5740)

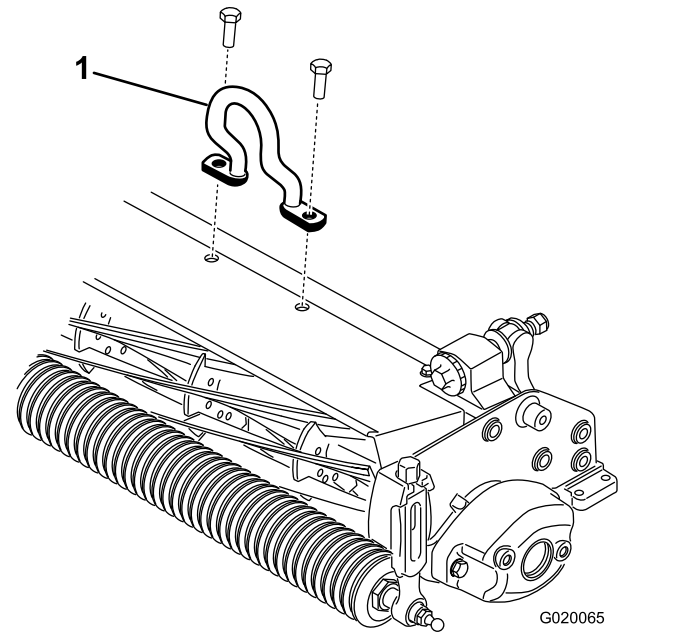

**Figure 6**

- Offset link (Part No. 110-2397)

- For the Greensmaster 3250-D traction units, install the offset link (Part No. 110-2397) supplied with the traction unit.

Install the offset link (Figure 6) to the top of the cutting unit with 2 bolts. Torque the bolts to 34 to 40 N·m (25 to 30 ft-lb).

**Important:** Position the lift hook offset toward the front of the cutting unit.

# 4

## Repositioning the Counter Weights

No Parts Required

### Procedure

The cutting units are shipped with the counter weight mounted to the left end and the motor mount to the right end of the cutting unit. To change the cutting unit to different positions, proceed as follows:

**Important:** Whenever you need to tip the cutting unit on its side, ensure that you prop it up to avoid damaging the bedbar-adjusting bolts; refer to [Supporting the Cutting Unit \(page 13\)](#)

1. Remove the 2 bolts securing the counter weight to the left end of the cutting unit. Remove the counter weight ([Figure 8](#)).
2. Remove the 2 Allen head bolts securing the motor mount to the left end of the cutting unit. Remove the motor mount ([Figure 7](#)).
3. Apply grease to the inside diameter of the drive spline ([Figure 7](#)).
4. On the left end of the cutting unit, apply a light coating of oil to the O-ring and install the motor mount with the 2 Allen head bolts previously removed ([Figure 7](#)). Torque the bolts to 16 to 20 N·m (12 to 15 ft-lb).

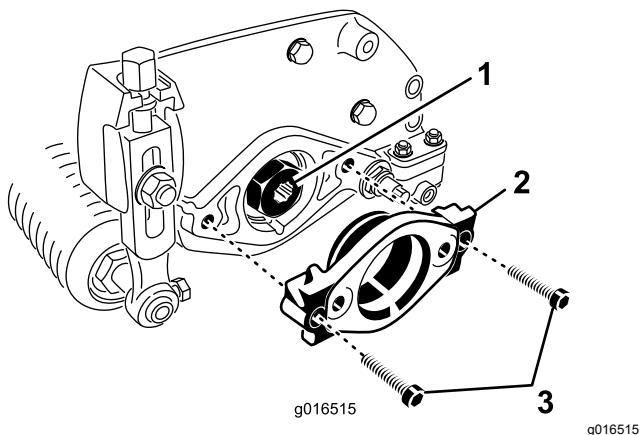

Figure 7

1. Drive spline
2. Motor mount
3. Allen head bolts

weight with the bolts previously removed ([Figure 8](#)). Torque the bolts to 16 to 20 N·m (12 to 15 ft-lb).

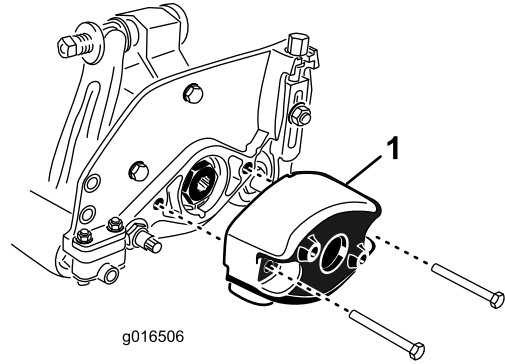

Figure 8

1. Counter weight

# 5

## Adjusting the Cutting Unit

No Parts Required

### Procedure

1. Support the cutting unit; refer to [Supporting the Cutting Unit \(page 13\)](#).
2. Adjust the cut-off bar.
3. Adjust the bedknife-to-reel contact.
4. Adjust the rear roller height.
5. Adjust the height of cut.

Refer to [Adjusting the Cutting Unit \(page 8\)](#) for complete instructions for performing these adjustments.

5. On the right end of the cutting unit, apply a light coating of oil to the O-ring and install the counter

# Product Overview

## Specifications

Model Number	Weight
04652	30 kg (65 lb)
04654	31 kg (68 lb)
04656	32 kg (71 lb)

## Attachments/Accessories

A selection of Toro approved attachments and accessories is available for use with the machine to enhance and expand its capabilities. Contact your Authorized Service Dealer or authorized Toro distributor or go to [www.Toro.com](http://www.Toro.com) for a list of all approved attachments and accessories.

To ensure optimum performance and continued safety certification of the machine, use only genuine Toro replacement parts and accessories. Replacement parts and accessories made by other manufacturers could be dangerous, and such use could void the product warranty.

# Operation

Refer to your traction unit *Operator's Manual* for detailed operation instructions. Before using the cutting unit each day, adjust the bedknife; refer to [Adjusting the Bedknife-to-Reel Contact \(page 9\)](#). Test the quality of cut by cutting a test swath before using the cutting unit to ensure that the finished cut is correct.

## Adjusting the Cutting Unit

### Adjusting the Cut-Off Bar

Adjust the cut-off bar to ensure that the clippings are cleanly discharged from the reel area, as follows:

**Note:** The bar is adjustable to compensate for changes in turf conditions. Adjust the bar closer to the reel when the turf is extremely dry. By contrast, adjust the bar further away from the reel when the turf conditions are wet. The bar should be parallel to the reel to ensure optimum performance. Adjust it whenever you sharpen the reel.

1. Loosen the bolts securing the top bar ([Figure 9](#)) to the cutting unit.

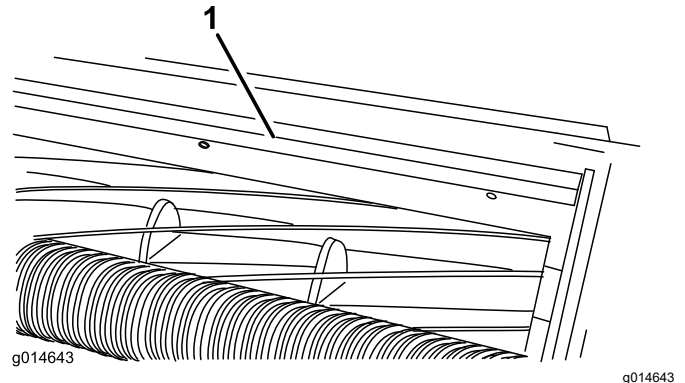

**Figure 9**

1. Cut-off bar

2. Insert a 1.5 mm (0.060 inch) feeler gauge between the top of the reel and the bar then tighten the bolts.

**Important:** Ensure that the bar and reel are equal distance apart across the complete reel.

**Note:** Adjust the gap as needed for your turf conditions.



# Adjusting the Bedknife-to-Reel Contact

## Adjusting the Bedknife Daily

Prior to mowing each day, or as required, verify proper bedknife-to-reel contact. **Perform this procedure even though the quality of cut is acceptable.**

1. Lower the cutting units onto a hard surface, shut off the engine, and remove the ignition key.
2. Slowly rotate the reel in a reverse direction, listening for reel-to-bedknife contact.
  - If no contact is evident, adjust the bedknife as follows:
    - A. Turn the bedbar adjusting screws clockwise ([Figure 10](#)), 1 click at a time, until you feel and hear light contact.

**Note:** The bedbar adjusting screws have detents corresponding to 0.018 mm (0.0007 inch) bedknife movement for each indexed position.

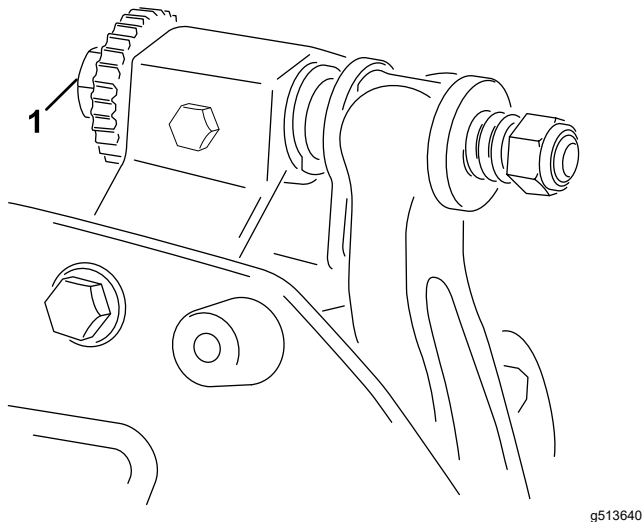

**Figure 10**

1. Bedbar adjusting screw (2)

B. Insert a long strip of cutting performance paper between the reel and bedknife, perpendicular to the bedknife ([Figure 11](#)), then **slowly** rotate the reel forward; it should cut the paper; if not, repeat steps [A](#) and [B](#) until it does.

- If excessive contact/reel drag is evident, backlap, reface the front of the bedknife, or grind the cutting unit to achieve the sharp edges needed for precision cutting (Refer to the *Toro Manual for Sharpening Reel and Rotary Mowers*, Form No. 09168SL).

**Important:** Light contact is preferred at all times. If you do not maintain light contact,

the bedknife/reel edges do not sufficiently self-sharpen, resulting in dull cutting edges after a short period of operation. If you maintain excessive contact, bedknife/reel wear is accelerated, uneven wear can result, and the quality of cut may decline.

**Note:** As the reel blades continue to run against the bedknife, a slight burr will appear on the front cutting edge surface along the full length of the bedknife. Occasionally run a file across the front edge to remove this burr to improve cutting. After extended running, a ridge will eventually develop at both ends of the bedknife. Round off these notches or file them flush with the cutting edge of the bedknife to ensure smooth operation.

## Adjusting the Bedknife to the Reel

Use this procedure during initial cutting-unit setup and after grinding, backlapping, or disassembling the reel. This is not a daily adjustment.

1. Position the cutting unit on a flat, level work surface.
2. Tip the cutting unit to expose the bedknife and reel.

**Note:** Ensure that the nuts on the back of the bedbar adjusting bolts are not resting on the work surface ([Figure 16](#)).

3. Rotate the reel so that 1 of the blades crosses the bedknife edge between the first and second bedknife bolt heads located on the right side of the cutting unit.
4. Make an identifying mark on the blade where it crosses the bedknife edge.

**Note:** This makes later adjustments easier.

5. Insert a 0.05 mm (0.002 inch) shim (Toro Part No. 140-5531) between the blade and the bedknife edge at the point marked in step 4.
6. Turn the right bedbar adjusting bolt ([Figure 10](#)) until you feel light pressure on the shim when sliding it side-to-side. Remove the shim.
7. For the left side of the cutting unit, slowly rotate the reel so that the closest blade crosses the bedknife edge between the first and second bolt heads.
8. Repeat steps 4 through 6 for the left side of the cutting unit and left bedbar adjusting bolt.
9. Repeat steps 5 and 6 until there is light pressure at the contact points on both the left and right sides of the cutting unit.
10. To obtain light contact between the reel and bedknife, turn each bedbar adjusting bolt clockwise 3 clicks.

**Note:** Each click on the bedbar adjusting bolt moves the bedknife 0.018 mm (0.0007 inches).

**Do not overtighten the adjusting bolts.**

Turning the adjusting bolt clockwise moves the bedknife edge closer to the reel. Turning the adjusting bolt counterclockwise moves the bedknife edge away from the reel.

11. Insert a long strip of cutting performance paper (Toro Part No. 125-5610) between the reel and bedknife, perpendicular to the bedknife (Figure 11), then **slowly** rotate the reel forward; it should cut the paper; if not, turn each bedbar adjusting bolt clockwise 1 click and repeat this step until it cuts the paper.

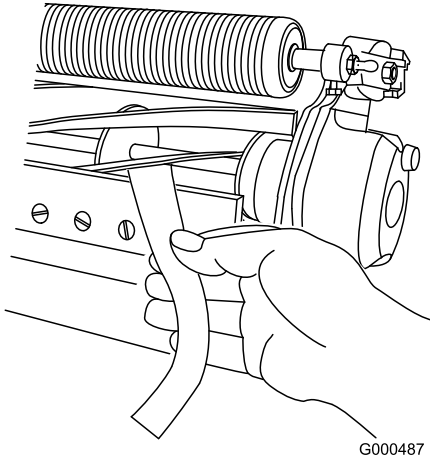
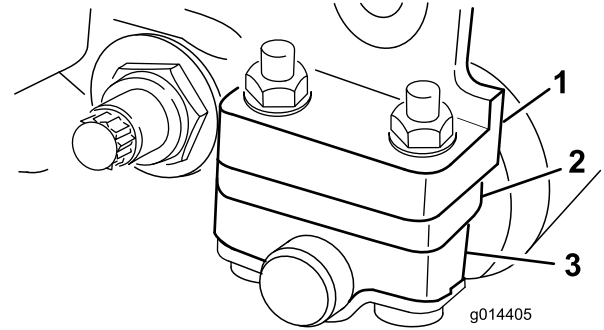

**Figure 11**

**Note:** If excessive contact/reel drag is evident, backlap, reface the front of the bedknife, or grind the cutting unit to achieve the sharp edges needed for precision cutting (Refer to the *Toro Manual for Sharpening Reel and Rotary Mowers*, Form No. 09168SL).

## Adjusting the Rear-Roller Height

1. Adjust the rear roller brackets to the desired height-of-cut range by positioning the required amount of spacers below the sideplate-mounting flange (Figure 12) per the [Height-of-Cut and Bedknife Selection Charts](#) (page 12).



**Figure 12**

1. Sideplate-mounting flange
2. Spacer
3. Roller bracket

2. Raise the rear of the cutting unit and place a block under the bedknife.
3. Remove the 2 nuts securing each roller bracket and spacer(s) to each sideplate-mounting flange.
4. Lower the roller bracket and bolts from the sideplate-mounting flanges and spacers.
5. Place the spacers onto the bolts on the roller brackets.
6. Secure the roller bracket and spacers to the underside of the mounting flanges with the nuts previously removed.

**Note:** Place unused spacers on top of the sideplate-mounting flange for later use.

**Note:** The position of the rear roller to the reel is controlled by the machining tolerances of the assembled components and paralleling is not required.

# Adjusting the Height of Cut

Set the height of cut to the desired height using a height-of-cut gauge, and ensure that your cutting unit is equipped with a bedknife that is best suited for your desired height of cut; refer to [Height-of-Cut and Bedknife Selection Charts](#) (page 12).

## Adjusting the Height-of-Cut Gauge

Before adjusting the height of cut, set the height-of-cut gauge as follows:

1. Loosen the nut on the gauge bar and set the adjusting bolt to the desired height of cut ([Figure 13](#)).

**Note:** The distance between the bottom of the bolt head and the face of bar is the height of cut.

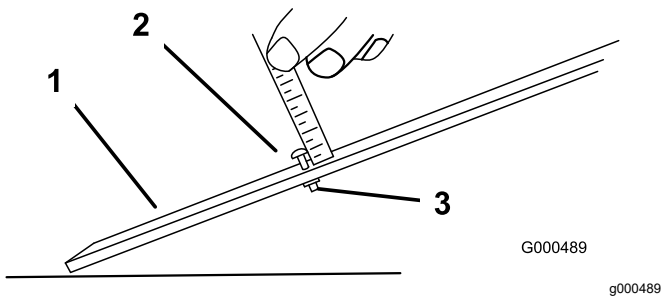

Figure 13

1. Gauge bar
2. Height-adjusting bolt
3. Nut

2. Tighten the nut.

## Adjusting the Height of Cut

1. Loosen the locknuts securing the height-of-cut arms to the cutting-unit side plates ([Figure 14](#)).

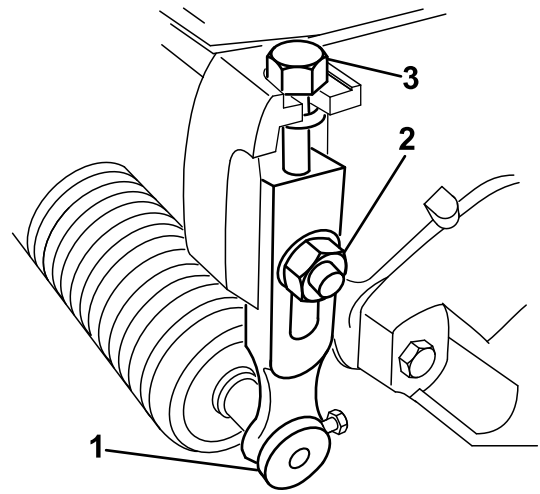

Figure 14

1. Height-of-cut arm
2. Locknut
3. Adjusting bolt

2. Hook the bolt head of the height-of-cut gauge onto the right side of the cutting edge of the bedknife and rest the rear end of the bar onto the rear of the roller ([Figure 15](#)).

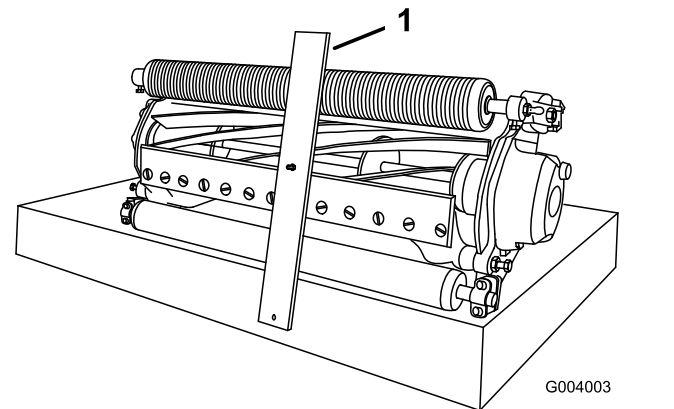

Figure 15

1. Gauge bar
  3. Rotate the adjusting bolt until the roller contacts the front of the gauge bar.
  4. Repeat steps 2 and 3 for the left side.
  5. Adjust both ends of the roller until the entire roller is parallel to the bedknife.
- Important:** When set properly, the rear and front rollers contact the gauge bar and the bolt is snug against the bedknife. This ensures that the height of cut is identical at both ends of the bedknife.
6. Tighten the nuts to secure the adjustment enough to remove play from the washer.
  7. Verify that the height-of-cut setting is correct; repeat this procedure if necessary.

# Height-of-Cut and Bedknife Selection Charts

Height-of-Cut Chart			
Height of Cut (mm)	Height of Cut (inches)	No. of Rear Spacers	Universal Groomer
1.5	0.060	0	Y
3.2	0.125	0	Y
4.8	0.188	0	Y
6.4	0.250	0	Y
6.4	0.250	1	Y
9.5	0.375	0	Y
9.5	0.375	1	Y
12.7	0.500	1	N
12.7	0.500	2*	Y**
15.9	0.625	2*	N
15.9	0.625	3*	Y**
19.1	0.750	3*	N
19.1	0.750	4*	Y**
22.2	0.875	4*	N
25.4	1.000	4*	N

\* 2 or more rear spacers requires the High HOC Kit (Part No. 120-9600).  
 \*\* 2 or more rear spacers for the Universal Groomer requires the High HOC Kit (Part No. 133-9110).

Use the following chart to determine which bedknife is best suited for the desired height of cut.

Bedknife/Height-of-Cut Selection Chart			
Bedknife	Part No.	Height of Cut	Top Grind Angle
EdgeMax Micro-cut (Standard 04652, 04654, 04656)	115-1880	1.5 to 4.7 mm (0.062 to 0.188 inch)	3°
Micro-cut (Optional)	93-4262	1.5 to 4.7 mm (0.062 to 0.188 inch)	3°
Micro-cut Extended (Optional)	108-4303	1.5 to 4.7 mm (0.062 to 0.188 inch)	7°
EdgeMax Micro-cut Short (Optional)	139-4320	1.5 to 4.7 mm (0.062 to 0.188 inch)	3°
EdgeMax Tournament (Optional)	115-1881	3.1 to 12.7 mm (0.125 to 0.500 inch)	3°
Tournament (Optional)	93-4263	3.1 to 12.7 mm (0.125 to 0.500 inch)	3°
Tournament Extended (Optional)	108-4302	3.1 to 12.7 mm (0.125 to 0.500 inch)	7°
EdgeMax Tournament Short (Optional)	139-4321	3.1 to 12.7 mm (0.125 to 0.500 inch)	3°
Low-cut (Optional)	93-4264	4.7 to 25.4 mm (0.188 to 1.00 inch)	3°
High-cut (Optional)	94-6392	7.9 to 25.4 mm (0.312 to 1.00 inch)	3°
EdgeMax Fairway (Optional)	137-6092	9.5 to 25.4 mm (0.375 to 1.00 inch)	10°
Fairway (Optional)	137-6097	9.5 to 25.4 mm (0.375 to 1.00 inch)	10°

**Note:** Use extended or short bedknives for less or more aggressive cut.

# Maintenance

**Note:** Determine the left and right sides of the machine from the normal operating position.

## Supporting the Cutting Unit

Whenever you need to tip the cutting unit to expose the bedknife/reel, prop up the rear of the cutting unit to ensure that the nuts on the back end of the bedbar-adjusting bolts are not resting on the work surface (Figure 16).

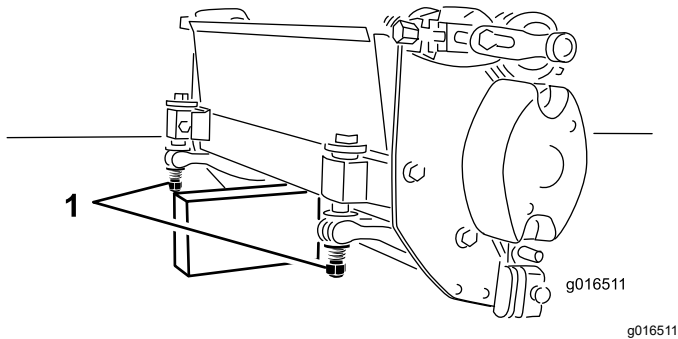

**Figure 16**

1. Bedbar-adjusting-screw nut (2)

## Servicing the Bedbar

Only a properly trained mechanic should service the bedbar and bedknife to prevent damage to the reel, bedbar, or bedknife. Ideally, take the cutting unit to your authorized manufacturer distributor for service. Refer to the *Service Manual* for your traction unit for complete instructions, special tools, and diagrams for servicing the bedknife. Should you ever need to remove or assemble the bedbar yourself, instructions are provided below, as are the specifications for servicing the bedknife.

**Important:** Always follow the bedknife procedures detailed in your *Service Manual* when servicing the bedknife. Failure to install and grind the bed knife correctly can lead to damage to the reel, bedbar, or bedknife.

## Removing the Bedbar

1. Turn the bedbar adjusting screw, counterclockwise, to back the bedknife away from the reel (Figure 17).

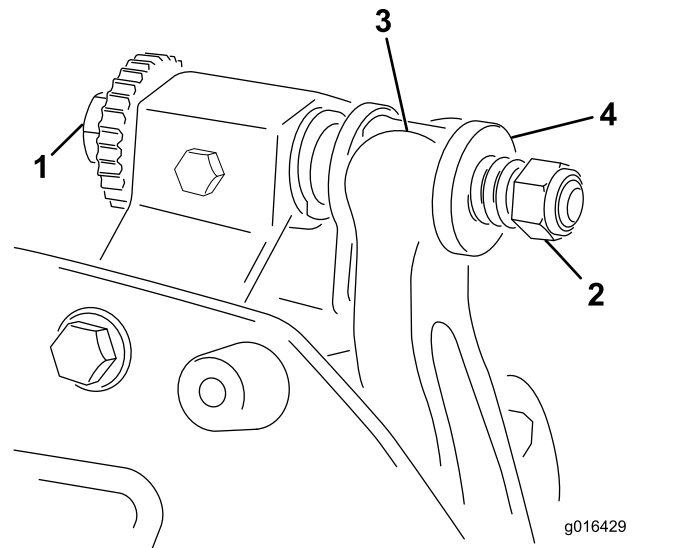

**Figure 17**

- |                           |           |
|---------------------------|-----------|
| 1. Bedbar-adjusting screw | 3. Bedbar |
| 2. Spring-tension nut     | 4. Washer |

2. Back out the spring-tension nut until the washer is no longer tensioned against the bedbar (Figure 17).
3. On each side of the machine, loosen the locknut securing the bedbar bolt (Figure 18).

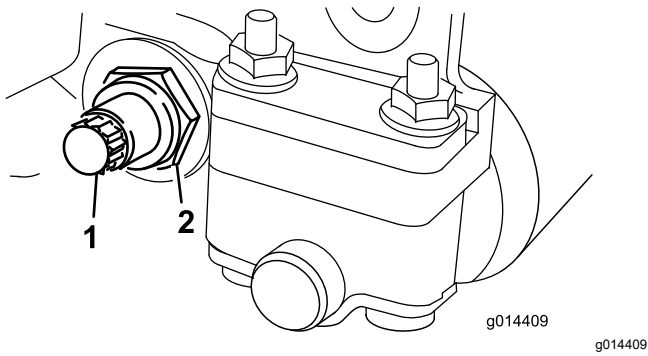
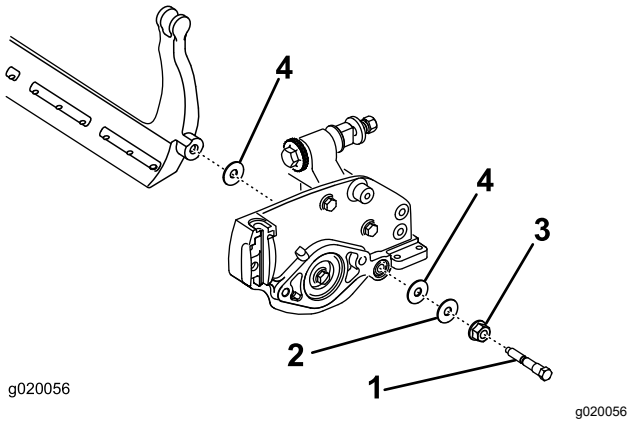

**Figure 18**

- |                |            |
|----------------|------------|
| 1. Bedbar bolt | 2. Locknut |
|----------------|------------|

- 
4. Remove each bedbar bolt allowing the bedbar to be pulled downward and removed from the cutting unit (Figure 18).

Account for the 2 nylon washers and 1 steel washer on each end of the bedbar (Figure 19).



**Figure 19**

- |                 |                 |
|-----------------|-----------------|
| 1. Bedbar bolt  | 3. Nut          |
| 2. Steel washer | 4. Nylon washer |

## Assembling the Bedbar

1. Install the bedbar, positioning the mounting ears between the washers and the bedbar-adjusting screw (Figure 17).

**Important:** Center the DPA adjusters in the bedbar ears as shown in Figure 20.

If DPA adjusters are installed against the bedbar ears, this may negatively affect the bedknife-to-reel contact.

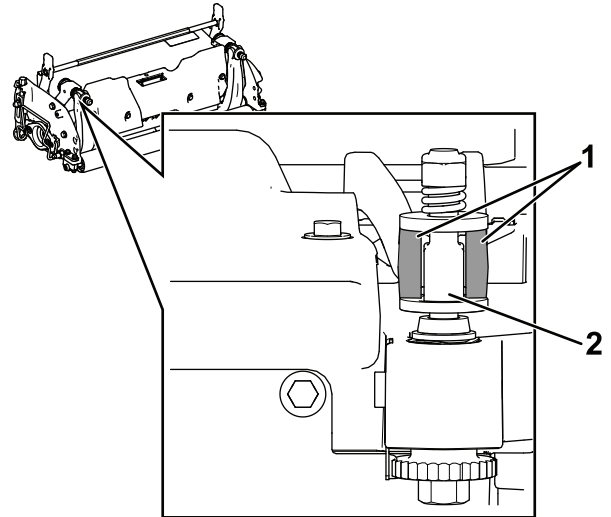

**Figure 20**

- |                |                 |
|----------------|-----------------|
| 1. Bedbar ears | 2. DPA adjuster |
|----------------|-----------------|

- 
2. Secure the bedbar to each side plate with the bedbar bolts (nuts on bolts) and 3 washers (6 total).
  3. Position a nylon washer on each side of the side-plate boss. Place a steel washer outside each of the nylon washers (Figure 19).
  4. Torque the bedbar bolts to 27 to 36 N·m (240 to 320 inch-lb).
  5. Tighten the locknuts until you remove the end play from steel washers, but you are able to rotate them by hand. The washers on the inside may have a gap.

**Important:** Do not overtighten the locknuts or they will deflect the side plates.

6. Tighten the spring tension nut until the spring is collapsed, then back it off 1/2 turn (Figure 21).

# Bedknife Specifications

## Installing the Bedknife

1. Remove the rust, scale, and corrosion from the bedbar surface and apply a thin layer of oil to the bedbar surface.
2. Clean the screw threads.
3. Apply never-seize compound to the screws and install the bedknife to the bedbar.

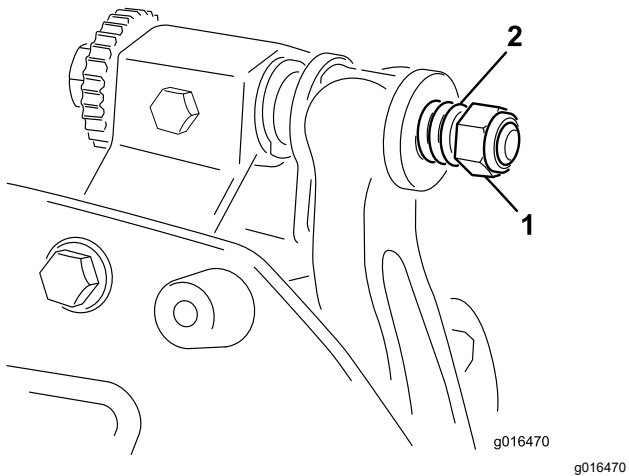

**Figure 21**

1. Spring-tension nut
2. Spring

- 
7. Adjust the bedknife to the reel; refer to [Adjusting the Bedknife to the Reel \(page 9\)](#).

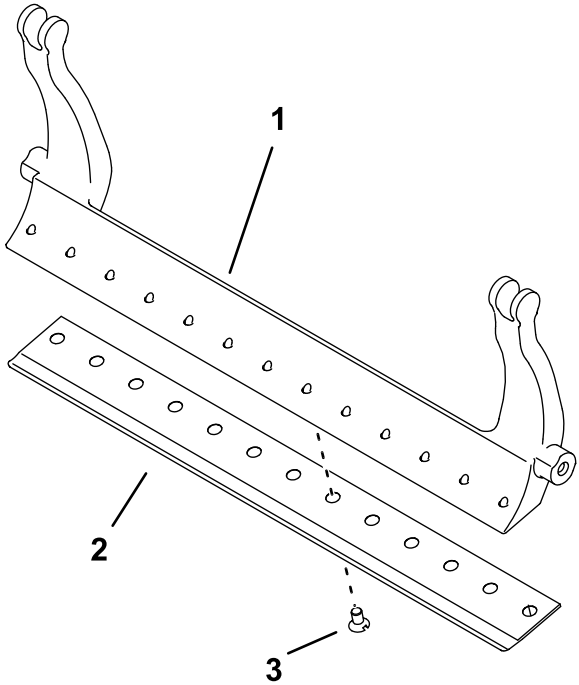
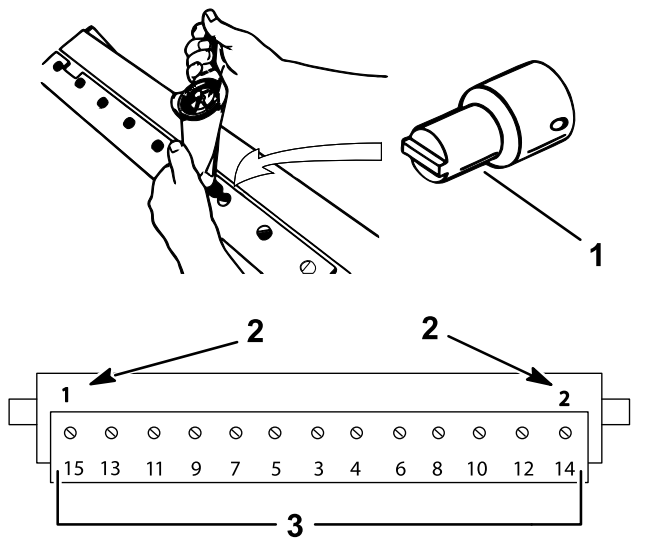

**Figure 22**

1. Bedbar
2. Bedknife
3. Screw

- 
4. Torque the 2 outer screws to 1 N·m (10 in-lb).
  5. Working from the center of the bedknife, torque the screws to 23 to 28 N·m (200 to 250 in-lb).





**Figure 23**

g255046

1. Bedknife screw tool
2. Install and torque these first to 1 N·m (10 in-lb).
3. Torque to 23 to 28 N·m (200 to 250 in-lb).

6. Grind the bedknife.

## Bedknife Grinding Specifications

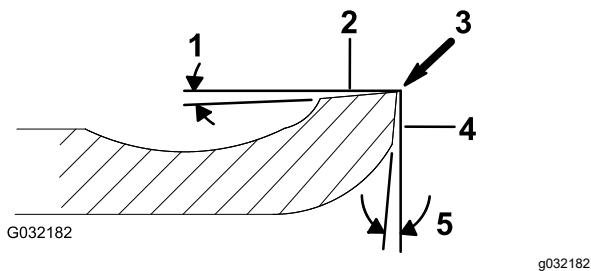

**Figure 24**

g032182

1. Relief angle
2. Top face
3. Remove burr
4. Front face
5. Front angle

Bedknife Relief (Top) Angle	Refer to <a href="#">Height-of-Cut and Bedknife Selection Charts</a> (page 12).
Front Angle Range	13° to 17°
Fairway Bedknife Front Angle	10°

## Checking the Top Grind Angle

The angle that you use to grind your bedknives is very important.

Use the angle indicator (Toro Part No. 131-6828) and the angle-indicator mount (Toro Part No. 131-6829) to check the angle that your grinder produces and then correct for any grinder inaccuracy.

1. Place the angle indicator on the bottom side of the bedknife as shown in [Figure 25](#).

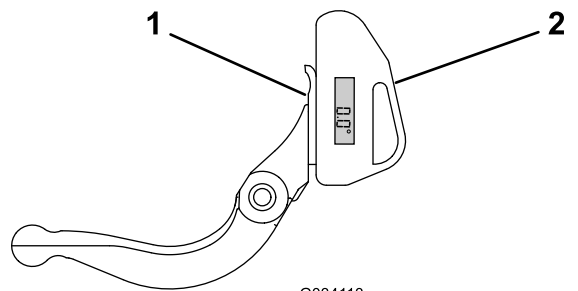

G034113

g034113

**Figure 25**

1. Bedknife (vertical)
2. Angle indicator

2. Press the Alt Zero button on the angle indicator.
3. Place the angle-indicator mount on the edge of the bedknife so that the edge of the magnet mates with the edge of the bedknife ([Figure 26](#)).

**Note:** The digital display should be visible from the same side during this step as it was in step 1.

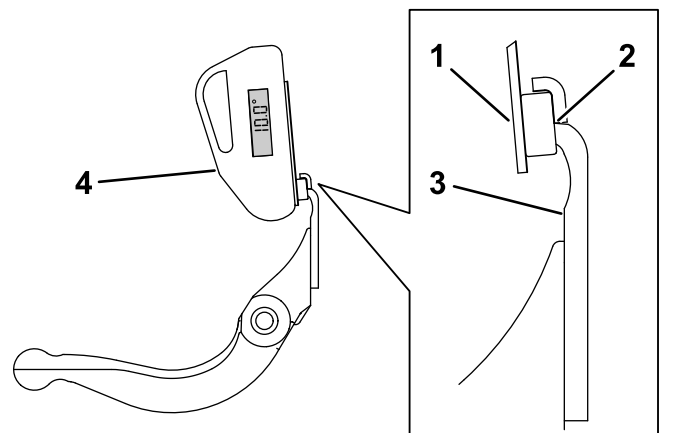

G034114

g034114

**Figure 26**

1. Angle-indicator mount
2. Edge of the magnet mated with the edge of the bedknife
3. Bedknife
4. Angle indicator

4. Place the angle indicator on the mount as shown in [Figure 26](#).

**Note:** This is the angle that your grinder produces, and should be within 2 degrees of the recommended top grind angle.



# Reel Specifications

## Preparing the Reel for Grinding

1. Ensure that all cutting unit components are in good condition and correct any issues before grinding.
2. Follow the reel grinder manufacturer's instructions to grind the cutting reel to the following specifications.

Reel Grinding Specifications	
New Reel Diameter	128.5 mm (5.06 inches)
Reel Diameter Service Limit	114.3 mm (4.50 inches)
Blade Relief Angle	30° ± 5°
Blade Land Width Range	0.8 to 1.2 mm (0.03 to 0.05 inches)
Reel Diameter Taper Service Limit	0.25 mm (0.010 inch)

## Relief-Grinding the Reel

The new reel has a land width of 0.8 to 1.2 mm (0.03 to 0.05 inches) and a 30° relief grind.

When the land width gets larger than 3 mm (0.120 inch) wide, do the following:

1. Apply a 30° relief grind on all reel blades until the land width is 0.8 mm (0.03 inches) wide (Figure 27).

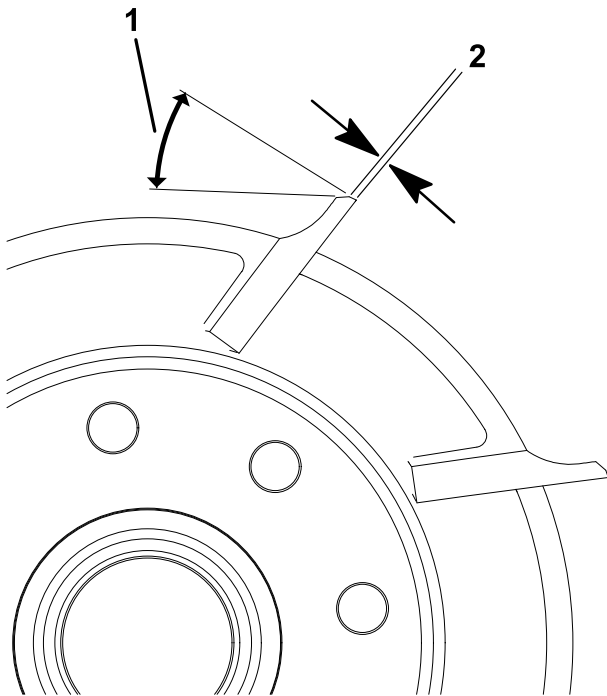

Figure 27

g278332

1. 30°
2. 0.8 mm (0.03 inches)

2. Spin grind the reel to achieve <0.025 mm (0.001 inch) reel run-out.

**Note:** This causes the land width to grow slightly.

3. Adjust the cutting unit; refer to your cutting unit *Operator's Manual*.

**Note:** To extend the longevity of the sharpness of the edge of the reel and the bedknife—after grinding the reel and/or the bedknife—check the reel to bedknife contact again after cutting 2 greens, as any burrs will be removed. Burrs may create improper reel to bedknife clearance, which can accelerate wear.

## Backlapping the Cutting Unit

### ⚠ DANGER

Contact with the reel or other moving parts can result in personal injury.

Keep your fingers, hands, and clothing away from the reels or other moving parts.

- Stay away from the reel while backlapping.
- Never use a short-handled paint brush for backlapping. Long-handled brushes are available from your local authorized Toro distributor.

1. Position the machine on a clean, level surface, lower the cutting units, stop the engine, engage the parking brake, and remove the ignition key.
2. Remove the reel motors from the cutting units and disconnect and remove the cutting units from the lift arms.
3. Connect the backlapping machine to the cutting unit by inserting a piece of 3/8 inch square stock into the splined coupling in the end of the cutting unit.

**Note:** Additional instructions and procedures on Backlapping are available in your traction unit *Operator's Manual* and the *Toro Sharpening Reel and Rotary Mowers Manual*, Form Number 80-300PT.

**Note:** For a better cutting edge, run a file across the front face of the bedknife and reel when the lapping operation is completed. This will remove any burrs or rough edges that may have built up on the cutting edge.

# Declaration of Incorporation

The Toro Company, 8111 Lyndale Ave. South, Bloomington, MN, USA declares that the following unit(s) conform(s) to the directives listed, when installed in accordance with the accompanying instructions onto certain Toro models as indicated on the relevant Declarations of Conformity.

Model No.	Serial No.	Product Description	Invoice Description	General Description	Directive
04652	408000000 and Up	8-Blade DPA Reel Mower	8 BLADE CUTTING UNIT NG DPA	8-Blade DPA Reel Mower	2006/42/EC, 2000/14/EC
04654	408000000 and Up	11-Blade DPA Reel Mower	11 BLADE CUTTING UNIT NG DPA	11-Blade DPA Reel Mower	2006/42/EC, 2000/14/EC
04656	408000000 and Up	14-Blade DPA Reel Mower	14 BLADE CUTTING UNIT NG DPA	14-Blade DPA Reel Mower	2006/42/EC, 2000/14/EC

Relevant technical documentation has been compiled as required per Part B of Annex VII of 2006/42/EC.

We will undertake to transmit, in response to requests by national authorities, relevant information on this partly completed machinery. The method of transmission shall be electronic transmittal.

This machinery shall not be put into service until incorporated into approved Toro models as indicated on the associated Declaration of Conformity and in accordance with all instructions, whereby it can be declared in conformity with all relevant Directives.

Certified:



Tom Langworthy  
Engineering Director  
8111 Lyndale Ave. South  
Bloomington, MN 55420, USA  
November 19, 2024

Authorized Representative:

Marcel Dutrieux  
Manager European Product Integrity  
Toro Europe NV  
Nijverheidsstraat 5  
2260 Oevel  
Belgium

# UK Declaration of Incorporation

The Toro Company, 8111 Lyndale Ave. South, Bloomington, MN, USA declares that the following unit(s) conform(s) to the directives listed, when installed in accordance with the accompanying instructions onto certain Toro models as indicated on the relevant Declarations of Conformity.

Model No.	Serial No.	Product Description	Invoice Description	General Description	Regulation
04652	408000000 and Up	8-Blade DPA Reel Mower	8 BLADE CUTTING UNIT NG DPA	8-Blade DPA Reel Mower	S.I. 2008 No. 1597, S.I. 2001 No. 1701
04654	408000000 and Up	11-Blade DPA Reel Mower	11 BLADE CUTTING UNIT NG DPA	11-Blade DPA Reel Mower	S.I. 2008 No. 1597, S.I. 2001 No. 1701
04656	408000000 and Up	14-Blade DPA Reel Mower	14 BLADE CUTTING UNIT NG DPA	14-Blade DPA Reel Mower	S.I. 2008 No. 1597, S.I. 2001 No. 1701

Relevant technical documentation has been compiled as required per Schedule 10 of S.I. 2008 No. 1597.

We will undertake to transmit, in response to requests by national authorities, relevant information on this partly completed machinery. The method of transmission shall be electronic transmittal.

This machinery shall not be put into service until incorporated into approved Toro models as indicated on the associated Declaration of Conformity and in accordance with all instructions, whereby it can be declared in conformity with all relevant Regulations.

This declaration has been issued under the sole responsibility of the manufacturer.  
The object of the declaration is in conformity with relevant UK legislation.



Tom Langworthy  
Engineering Director  
8111 Lyndale Ave. South  
Bloomington, MN 55420, USA  
November 19, 2024

Authorized Representative:

Marcel Dutrieux  
Manager European Product Integrity  
Toro U.K. Limited  
Spellbrook Lane West  
Bishop's Stortford  
CM23 4BU  
United Kingdom



# The Toro Warranty

Two-Year or 1,500 Hours Limited Warranty

## Conditions and Products Covered

The Toro Company warrants your Toro Commercial product ("Product") to be free from defects in materials or workmanship for 2 years or 1,500 operational hours\*, whichever occurs first. This warranty is applicable to all products with the exception of Aerators (refer to separate warranty statements for these products). Where a warrantable condition exists, we will repair the Product at no cost to you including diagnostics, labor, parts, and transportation. This warranty begins on the date the Product is delivered to the original retail purchaser.

\* Product equipped with an hour meter.

## Instructions for Obtaining Warranty Service

You are responsible for notifying the Commercial Products Distributor or Authorized Commercial Products Dealer from whom you purchased the Product as soon as you believe a warrantable condition exists. If you need help locating a Commercial Products Distributor or Authorized Dealer, or if you have questions regarding your warranty rights or responsibilities, you may contact us at:

Toro Commercial Products Service Department  
8111 Lyndale Avenue South  
Bloomington, MN 55420-1196

952-888-8801 or 800-952-2740  
E-mail: [commercial.warranty@toro.com](mailto:commercial.warranty@toro.com)

## Owner Responsibilities

As the product owner, you are responsible for required maintenance and adjustments stated in your *Operator's Manual*. Repairs for product issues caused by failure to perform required maintenance and adjustments are not covered under this warranty.

## Items and Conditions Not Covered

Not all product failures or malfunctions that occur during the warranty period are defects in materials or workmanship. This warranty does not cover the following:

- Product failures which result from the use of non-Toro replacement parts, or from installation and use of add-on, or modified non-Toro branded accessories and products.
- Product failures which result from failure to perform recommended maintenance and/or adjustments.
- Product failures which result from operating the Product in an abusive, negligent, or reckless manner.
- Parts consumed through use that are not defective. Examples of parts which are consumed, or used up, during normal Product operation include, but are not limited to, brake pads and linings, clutch linings, blades, reels, rollers and bearings (sealed or greasable), bed knives, spark plugs, castor wheels and bearings, tires, filters, belts, and certain sprayer components such as diaphragms, nozzles, flow meters, and check valves.
- Failures caused by outside influence, including, but not limited to, weather, storage practices, contamination, use of unapproved fuels, coolants, lubricants, additives, fertilizers, water, or chemicals.
- Failure or performance issues due to the use of fuels (e.g. gasoline, diesel, or biodiesel) that do not conform to their respective industry standards.
- Normal noise, vibration, wear and tear, and deterioration. Normal "wear and tear" includes, but is not limited to, damage to seats due to wear or abrasion, worn painted surfaces, scratched decals or windows.

## Countries Other than the United States or Canada

Customers who have purchased Toro products exported from the United States or Canada should contact their Toro Distributor (Dealer) to obtain guarantee policies for your country, province, or state. If for any reason you are dissatisfied with your Distributor's service or have difficulty obtaining guarantee information, contact your Authorized Toro Service Center.

## Parts

Parts scheduled for replacement as required maintenance are warranted for the period of time up to the scheduled replacement time for that part. Parts replaced under this warranty are covered for the duration of the original product warranty and become the property of Toro. Toro will make the final decision whether to repair any existing part or assembly or replace it. Toro may use remanufactured parts for warranty repairs.

## Deep Cycle and Lithium-Ion Battery Warranty

Deep cycle and Lithium-Ion batteries have a specified total number of kilowatt-hours they can deliver during their lifetime. Operating, recharging, and maintenance techniques can extend or reduce total battery life. As the batteries in this product are consumed, the amount of useful work between charging intervals will slowly decrease until the battery is completely worn out. Replacement of worn out batteries, due to normal consumption, is the responsibility of the product owner. Note: (Lithium-Ion battery only): Refer to the battery warranty for additional information.

## Lifetime Crankshaft Warranty (ProStripe 02657 Model Only)

The Prostripe which is fitted with a genuine Toro Friction Disc and Crank-Safe Blade Brake Clutch (integrated Blade Brake Clutch (BBC) + Friction Disc assembly) as original equipment and used by the original purchaser in accordance with recommended operating and maintenance procedures, are covered by a Lifetime Warranty against engine crankshaft bending. Machines fitted with friction washers, Blade Brake Clutch (BBC) units and other such devices are not covered by the Lifetime Crankshaft Warranty.

## Maintenance is at Owner's Expense

Engine tune-up, lubrication, cleaning and polishing, replacement of filters, coolant, and completing recommended maintenance are some of the normal services Toro products require that are at the owner's expense.

## General Conditions

Repair by an Authorized Toro Distributor or Dealer is your sole remedy under this warranty.

**The Toro Company is not liable for indirect, incidental or consequential damages in connection with the use of the Toro Products covered by this warranty, including any cost or expense of providing substitute equipment or service during reasonable periods of malfunction or non-use pending completion of repairs under this warranty. Except for the Emissions warranty referenced below, if applicable, there is no other express warranty. All implied warranties of merchantability and fitness for use are limited to the duration of this express warranty.**

Some states do not allow exclusions of incidental or consequential damages, or limitations on how long an implied warranty lasts, so the above exclusions and limitations may not apply to you. This warranty gives you specific legal rights, and you may also have other rights which vary from state to state.

## Note Regarding Emissions Warranty

The Emissions Control System on your Product may be covered by a separate warranty meeting requirements established by the U.S. Environmental Protection Agency (EPA) and/or the California Air Resources Board (CARB). The hour limitations set forth above do not apply to the Emissions Control System Warranty. Refer to the Engine Emission Control Warranty Statement supplied with your product or contained in the engine manufacturer's documentation.