



Count on it.

Parts Catalog

30in Stand-On Aerator

Model No. 39521—Serial No. 40000000 and Up



Ordering Replacement Parts

To order replacement parts, please supply the part number, the quantity, and the description of each part desired.

Understanding Reference Numbers

Each identified part in an illustration has a reference number. The reference number for a part also appears in the parts list, along with other information about the part.

This catalog uses two special reference number formats, one to indicate parts in a service assembly and another to indicate the quantity of a given part in an illustration.

Service Assembly Reference Numbers

Parts in service assemblies have reference numbers in the form a:b. The a represents the reference number of the entire service assembly and the b represents a sequential number unique to each part within the service assembly.

For example, a wheel assembly might be identified by reference number 6, the tire by 6:1, the valve by 6:2, and the wheel by 6:3. When you order the assembly identified by reference number 6, you receive all parts identified by reference numbers 6:1, 6:2, and 6:3. However, you may also order any part individually. Reference numbers of this type appear in illustration and in parts lists.

Reference Numbers Indicating Quantity

In an illustration, if a reference number indicates more than one part, the reference number has the form nX y. The n represents the quantity of the part, the X is the multiplication symbol, and the y represents the reference number.

For example, in an illustration, the reference number 2X 37 means that two of the parts identified by reference number 37 are indicated.

Contents

Main Frame Assembly	4
Main Frame Decal Assembly No. 135-5938	6
Caster Wheel and Fork Assembly	8
Platform Assembly No. 116-9135	10
Tower Assembly	12
Ground Drive Assembly	14
Idler Arm Assembly No. 116-9307	16
RH Transaxle Assembly No. 135-1050	18
LH Transaxle Assembly No. 135-1051	20
Axle and Bearing Assembly No. 116-9545	22
Tine Assembly	24
RH Tine Wheel Assembly No. 135-2507	26
LH Tine Wheel Assembly No. 135-2510	28
Fuel Assembly	30
Motion Control Assembly	32
Electrical Assembly	34
Auxiliary Hydraulic Assembly	36
Hydraulic Cylinder Assembly No. 116-6969	38
Hydraulic Pump Assembly No. 116-9129	40
Engine Assembly	42
Attachments and Accessories	44

Main Frame Assembly (continued)

<i>Ref.</i>	<i>Part Number</i>	<i>Qty.</i>	<i>Description</i>	<i>Ref.</i>	<i>Part Number</i>	<i>Qty.</i>	<i>Description</i>
1	135-5938	1	Main Frame ASM	14	3234-40	4	Screw-HF
2		2	Front Caster ASM ●	18	104-8301	6	Nut-HF, NI
3	116-6536-01	1	Weight	19	3256-24	4	Washer-Plain
4	116-9135	1	Platform W/Rocker ASM	21	135-4629	2	Screw-Sems (3/8-16 X 1)
5	116-7300	1	Access Cover ASM	22	614672	2	Screw-Shoulder, HWH
5:2	121-6163	1	Decal-Operation, Tine Ground (CE)	23	1-811010	2	Plug
6	116-8258	1	Muffler Guard ASM	24	3256-6	2	Washer-Flat
6:2	115-2047	2	Decal-Surface, Hot	28	107-1865	2	R-Clamp
8	99-5107	4	Nut-Lock	29	32144-10	2	Screw-HWH
9	126-0015	2	Grommet	30	104-7050	1	Tube-Manual
10	116-6612-01	1	Guard-Chain, RH	31	104-7048	1	Cap-Housing
11	116-6611-01	1	Guard-Chain, LH	33	133-8062	1	Decal-Spark Arrestor
				35	323-6	4	Screw-HH

● Not serviced separately

Main Frame Decal Assembly No. 135-5938

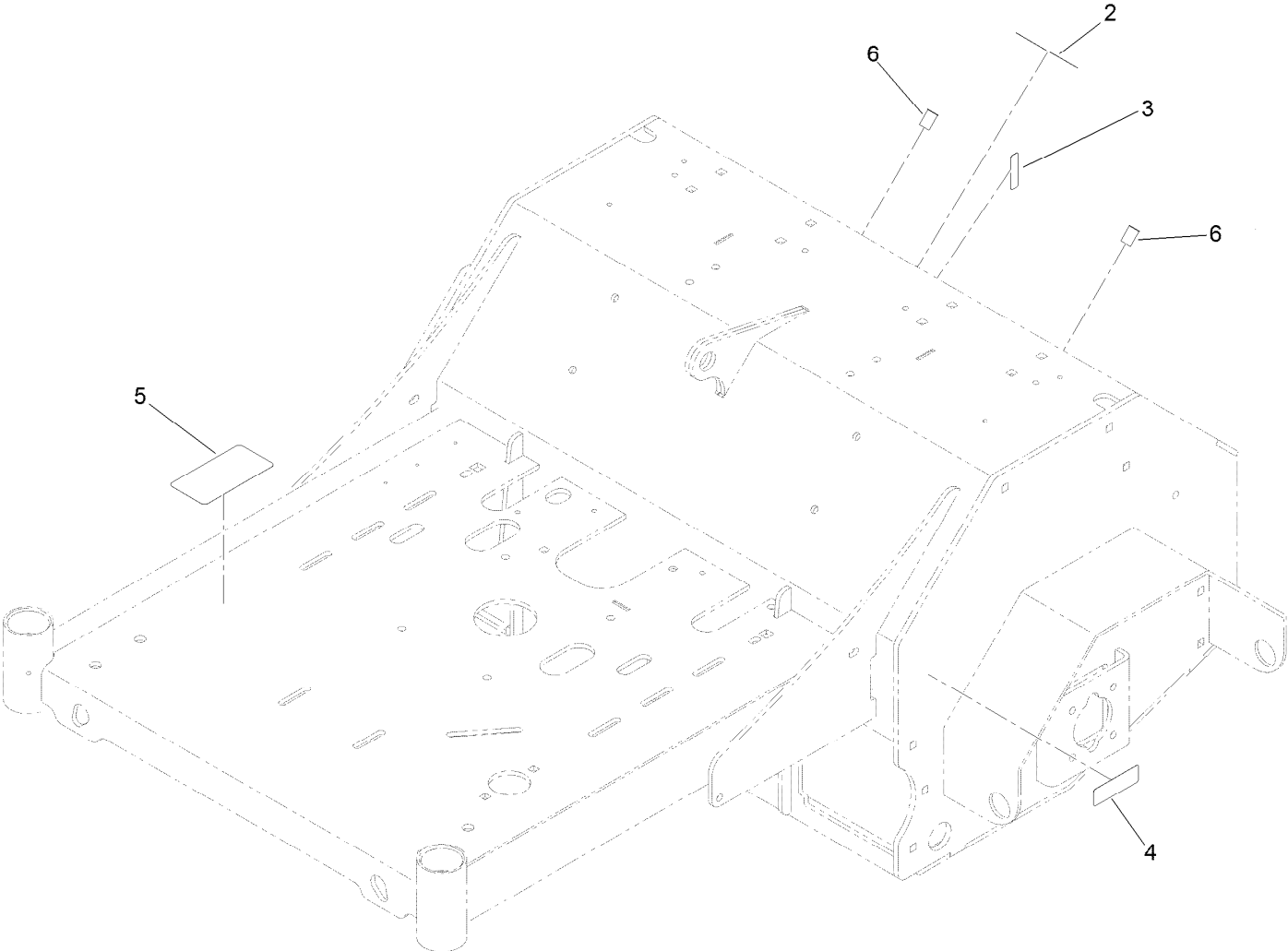

Main Frame Decal Assembly No. 135-5938 (continued)

<i>Ref.</i>	<i>Part Number</i>	<i>Qty.</i>	<i>Description</i>	<i>Ref.</i>	<i>Part Number</i>	<i>Qty.</i>	<i>Description</i>
2	121-6150	1	Decal-Warning	5	116-9391	1	Decal-Routing, Belt
3	120-9570	1	Decal-Warning	6	32148-10	2	Nut-Clinch
4	121-6161	2	Decal-Danger				

Caster Wheel and Fork Assembly

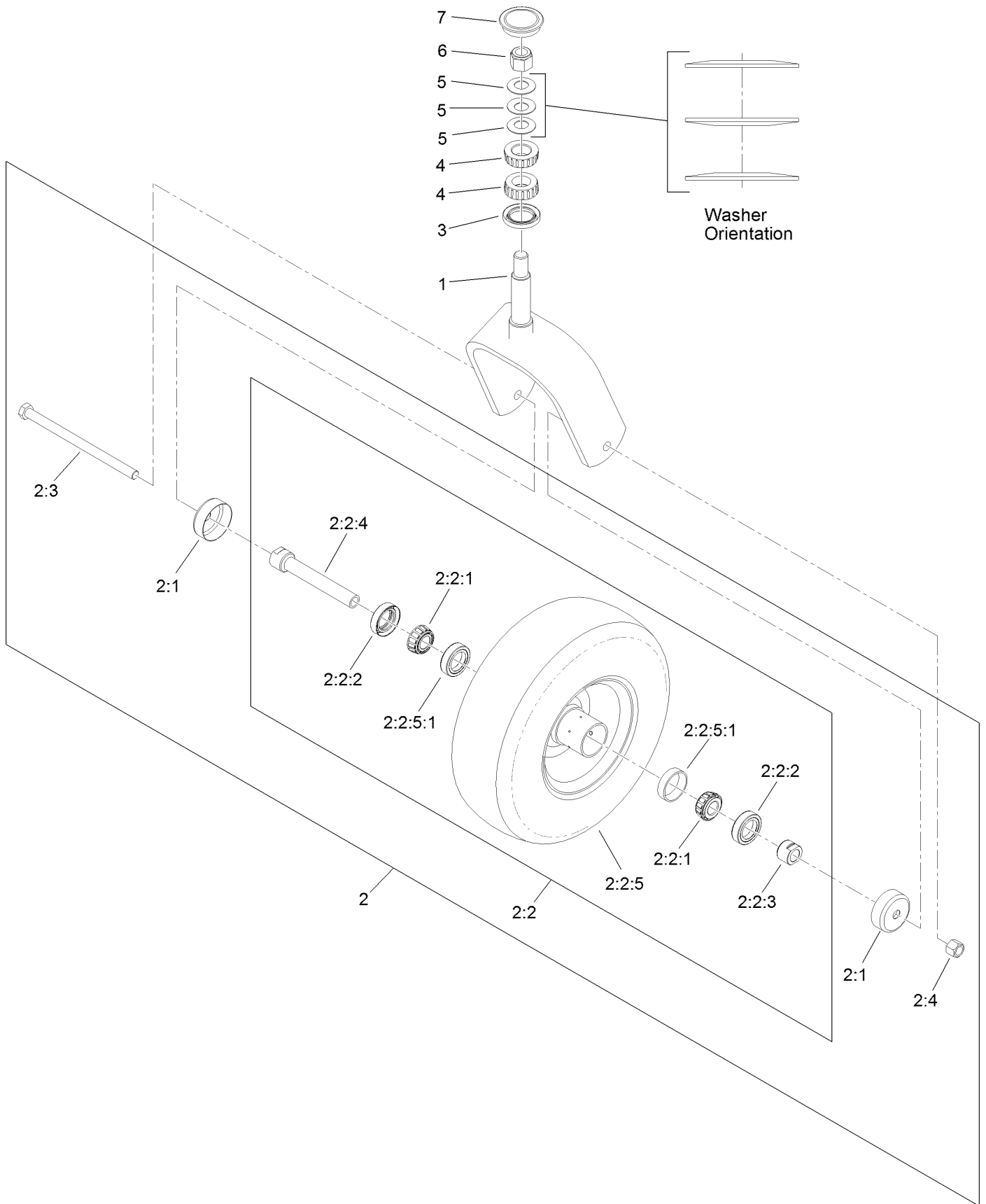

Caster Wheel and Fork Assembly (continued)

<i>Ref.</i>	<i>Part Number</i>	<i>Qty.</i>	<i>Description</i>	<i>Ref.</i>	<i>Part Number</i>	<i>Qty.</i>	<i>Description</i>
1	116-6704-01	1	Caster	2:2:5:1	1-633584	2	Bearing-Cup
2	127-9531	1	Wheel And Axle ASM	2:3	325-42	1	Screw-HH
2:1	103-2768	2	Guard-Seal	2:4	3296-23	1	Nut-Lock, NI
2:2		1	Wheel And Bearing ASM ●	3	116-5647	1	Seal-Grease
2:2:1	1-633585	2	Bearing-Cone, Taper	4	1-543509	2	Bearing-Roller, Tapered
2:2:2	103-0063	2	Seal-Caster	5	1-633508	3	Washer-Bellville
2:2:3	103-3051	1	Spacer-Nut ■	6	3296-51	1	Nut-Lock, NI
2:2:4	126-5360	1	Axle-Caster	7	103-4882	1	Cap-Grease
2:2:5		1	Wheel And Tire ASM ●				

● Not serviced separately

■ Use Pro-Lock, Nut Type (P/N 1-840022, .5ml tube) on threads.

Platform Assembly No. 116-9135

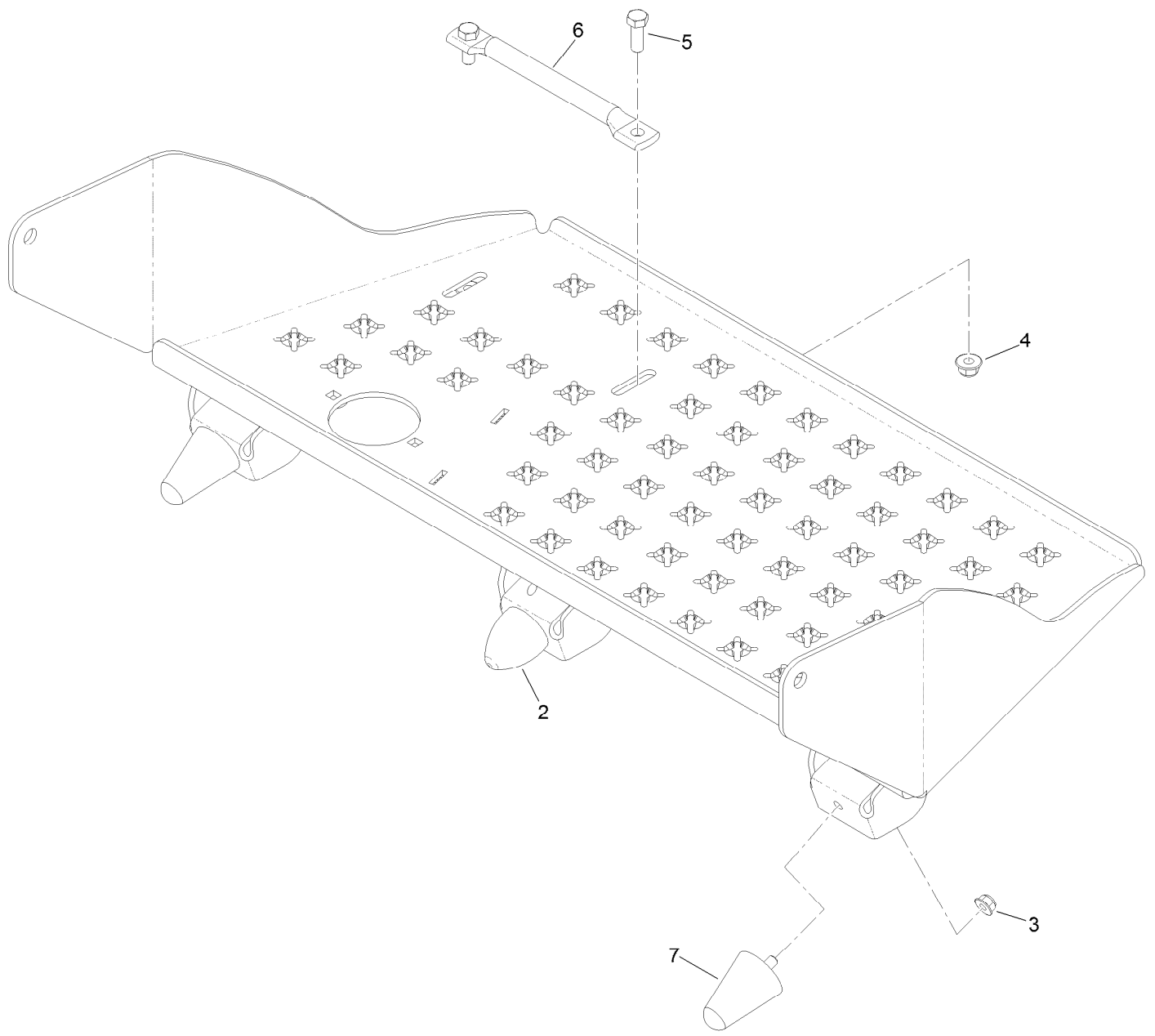

Platform Assembly No. 116-9135 (continued)

<i>Ref.</i>	<i>Part Number</i>	<i>Qty.</i>	<i>Description</i>
2	114-1926	1	Bumper-Rubber
3	104-8300	3	Nut-HF, NI
4	104-8301	2	Nut-HF, NI

<i>Ref.</i>	<i>Part Number</i>	<i>Qty.</i>	<i>Description</i>
5	323-6	2	Screw-HH
6	116-8950-01	1	Rocker-Pedal, Foot
7	114-1925	2	Bumper-Rubber

Tower Assembly

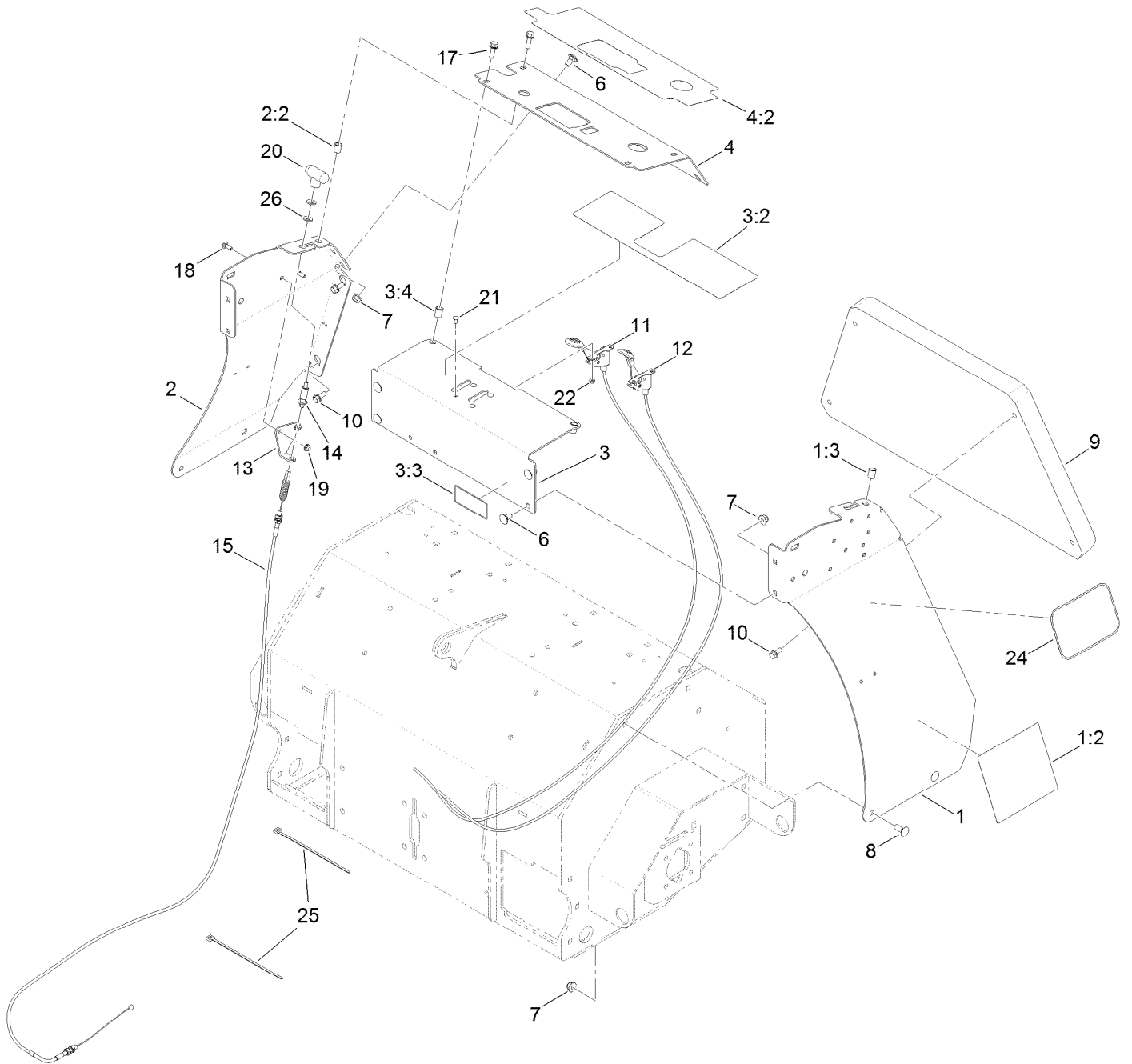

Tower Assembly (continued)

<i>Ref.</i>	<i>Part Number</i>	<i>Qty.</i>	<i>Description</i>	<i>Ref.</i>	<i>Part Number</i>	<i>Qty.</i>	<i>Description</i>
1	135-5949	1	LH Side Panel ASM	10	3234-5	4	Screw-HHF
1:2	116-9392	1	Decal-Service Aid (CE)	11	109-9147	1	Control-Choke
1:3	32148-7	1	Nut-Clinch	12	109-3958	1	Control-Throttle
2	116-7657	1	RH Side Panel ASM	13	116-6630	1	Bracket-Cable, Brake
2:2	32148-7	1	Nut-Clinch	14	116-7504	1	Link-Cable, Brake
3	135-6293	1	Front Console Plate ASM	15	116-7503	1	Cable-Brake
3:2	121-6164	1	Decal-Warning, Control Panel	17	3234-29	4	Screw-HHF
3:3	121-6162	1	Decal-Warning, Tines	18	3229-1	2	Screw-CARR
3:4	32148-7	2	Nut-Clinch	19	104-7201	2	Nut-HF, NI
4	135-5951	1	Console ASM	20	116-7607	1	Knob-Tee
4:2	135-5948	1	Decal-Panel, Control	21	1-807513	4	Bolt-CARR
6	3231-1	6	Screw-CARR	22	3296-2	4	Nut-Lock, NI
7	104-8301	10	Nut-HF, NI	24	62-5550	2	Decal
8	3231-2	4	Bolt-CARR	25	1-303335	2	Tie-Plastic
9	116-6959	1	Cushion-Black	26	3256-2	2	Washer-Flat

Ground Drive Assembly

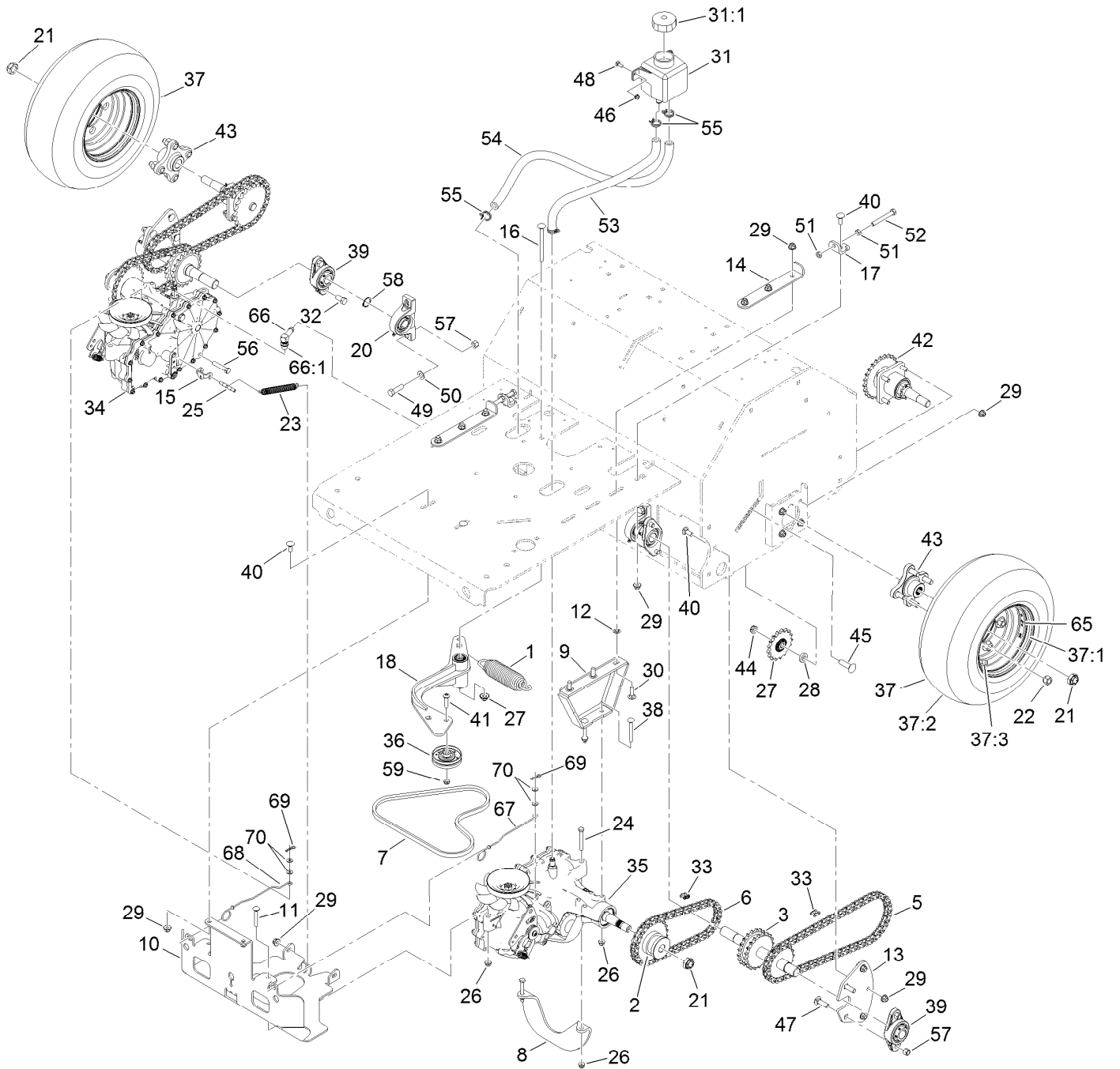

Ground Drive Assembly (continued)

<i>Ref.</i>	<i>Part Number</i>	<i>Qty.</i>	<i>Description</i>	<i>Ref.</i>	<i>Part Number</i>	<i>Qty.</i>	<i>Description</i>
1	116-6317	1	Spring-Extension	36	116-9715	1	Pulley-Idler
2	116-9305	2	Hub-Drive, Chain	37	126-4267	2	Wheel And Tire ASM
3	126-5625	2	Jackshaft	37:1	126-4266	1	Rim-Gray
5	126-8808	2	Chain-Roller	37:2	116-6978	1	Tire
6	126-8807	2	Chain-Roller	37:3	232-27	1	Stem-Valve
7	116-8874	1	Belt-4L Section	38	3230-9	4	Screw-CARR
8	135-5051-03	1	Brace-Angle	39	116-6777	4	Bearing-Flange, 2 Bolt
9	116-9710-03	2	Mount-Transmission	40	3231-2	10	Bolt-CARR
10	126-5495-03	1	Guard-Transmission	41	116-9927	1	Screw-HSBH
11	3230-7	2	Bolt-CARR	42	116-9545	2	Axle And Bearing ASM
12	107-3154	6	Nut-Push	43	116-3872	2	Hub-Offset
13	116-6596-01	2	Plate-Jackshaft	44	3296-45	2	Nut-Hex
14	116-6619	2	Plate-Adjustment, Transmission	45	3233-14	2	Screw-CARR
15	116-7597	1	Yoke-Brake, Park	46	104-7201	2	Nut-HF, NI
16	9000779	1	Bolt-CARR	47	3232-3	4	Bolt-CARR
17	116-6723	2	Bracket-Hydro, Adjust	48	3229-1	2	Screw-CARR
18	116-9307	1	Idler Arm ASM	49	324-6	4	Screw-HH
20	116-6756	2	Bearing-Pillow Block	50	3256-25	4	Washer-Flat
21	116-2839	4	Nut-Lock	51	3217-7	4	Nut-Hex
22	242-50	8	Nut-Lug	52	99-8664	2	Screw-HH
23	76-4660	1	Spring-Door	53	116-6775	1	Hose-Hydraulic
24	322-12	2	Screw-HH	54	116-6776	1	Hose-Hydraulic
25	116-7596	1	Pin-Brake, Park	55	109-3322	4	Clamp-Hose
26	104-8300	8	Nut-HF, NI	56	323-10	2	Screw-HH
27	126-9108	2	Sprocket-Idler, 15T	57	3296-48	8	Nut-Hex
28	104-8417	2	Washer	58	32151-29	2	Ring-Retaining
29	104-8301	27	Nut-HF, NI	59	3296-59	1	Nut-Lock, NI
30	3231-25	6	Bolt-CARR	65	126-2054	2	Decal-Hub, Wheel
31	109-2250	1	Tank-HYD	66	109-6449	1	Fitting-Elbow, 90
31:1	109-3320	1	Cap-Reservoir, HYD	66:1	237-42	1	O-Ring
32	116-7109	4	Screw-HH	67	135-0685	1	Rod-Bypass, RH
33	116-6897	4	Link-Connecting	68	135-0683	1	Rod-Bypass, LH
34	135-1050	1	RH Transaxle ASM (W/Pin)	69	1-806003	2	Pin-Cotter
35	135-1051	1	LH Transaxle ASM (W/Pin)	70	119-8952	4	Washer-Spcl

Idler Arm Assembly No. 116-9307

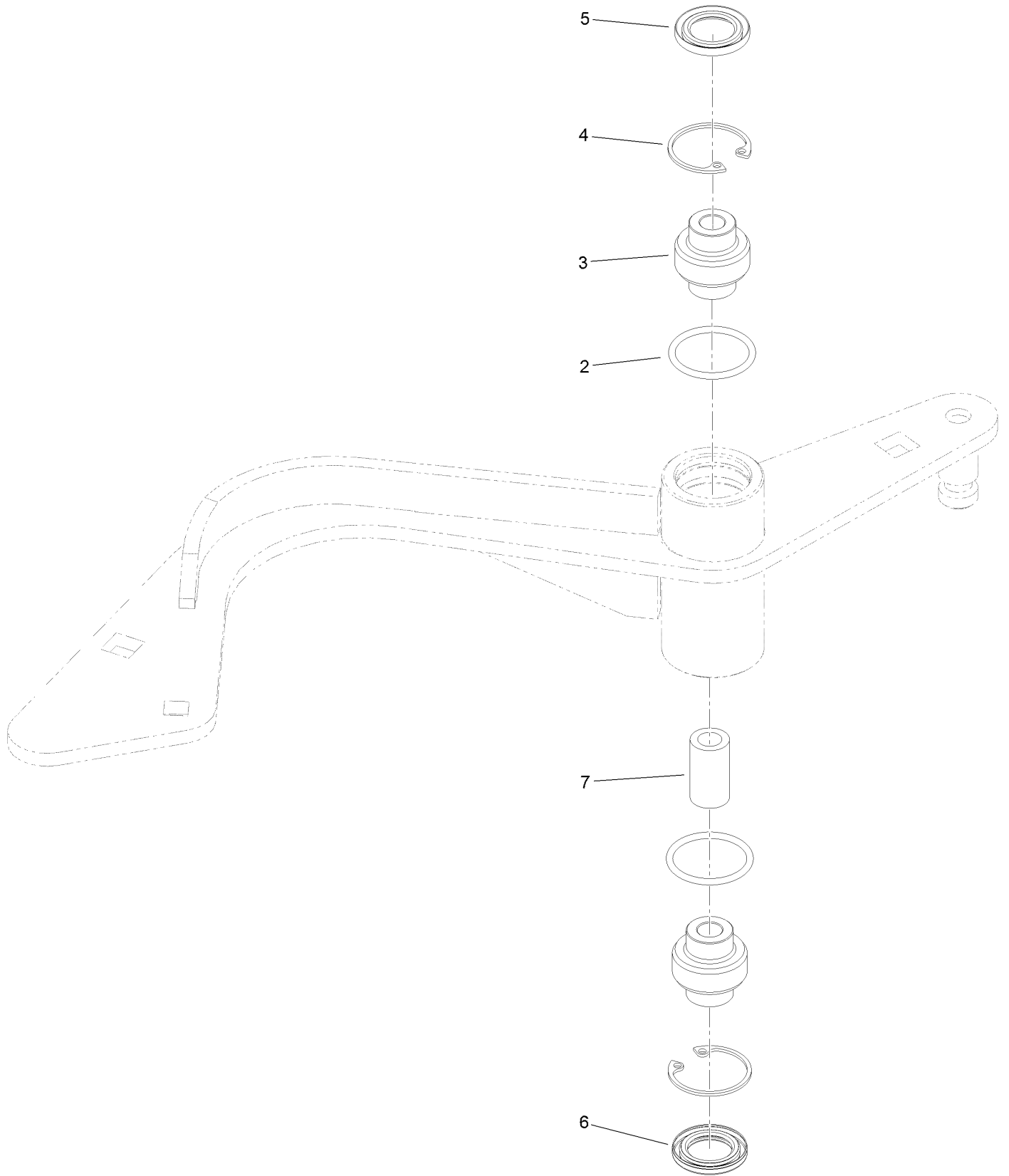

Idler Arm Assembly No. 116-9307 (continued)

<i>Ref.</i>	<i>Part Number</i>	<i>Qty.</i>	<i>Description</i>	<i>Ref.</i>	<i>Part Number</i>	<i>Qty.</i>	<i>Description</i>
2	106-7159	2	O-Ring	5	103-3506	1	Seal-Lip, Single
3	103-3504	2	Bearing-Spherical	6	103-3505	1	Seal-Lip, Double
4	32120-10	2	Ring-Snap	7	1-603401	1	Spacer

RH Transaxle Assembly No. 135-1050

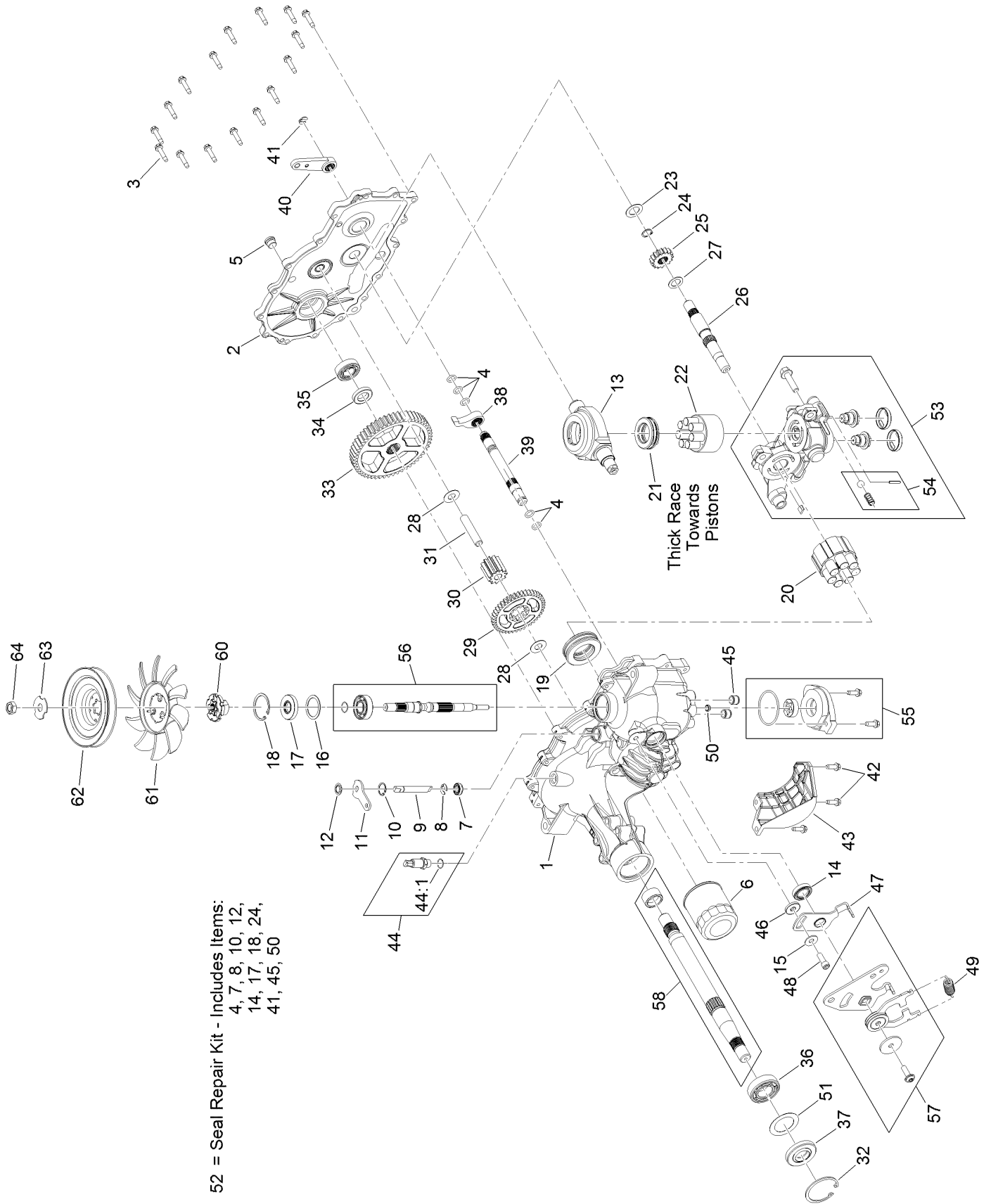

52 = Seal Repair Kit - Includes Items:
 4, 7, 8, 10, 12,
 14, 17, 18, 24,
 41, 45, 50

RH Transaxle Assembly No. 135-1050 (continued)

<i>Ref.</i>	<i>Part Number</i>	<i>Qty.</i>	<i>Description</i>	<i>Ref.</i>	<i>Part Number</i>	<i>Qty.</i>	<i>Description</i>
1	114-1676	1	Main Housing Kit	34	120-7975	1	Spacer
2	117-5358	1	RH Housing Side Kit	35	135-1361	1	Bearing-Ball
3	117-5359	16	Screw-HHF	36	120-7976	1	Bearing-Ball
4	114-1678	5	O-Ring	37	104-2144	1	Seal
5	135-1140	1	Plug-Straight	38	114-1697	1	Pawl-Brake
6	109-3321	1	Element-Oil Filter, HYD	39	114-1698	1	Shaft-Brake, Inboard
7	106-8676	1	Seal-Lip	40	125-0021	1	Handle-Brake
8	106-8677	1	Ring-Retaining, External	41	131-0906	1	Ring-Retaining, EXT
9	114-1685	1	Rod-Bypass	42	104-2120	3	Screw
10	106-8679	1	Ring-Retaining, Internal	43	120-7981	1	Guard-Filter, RH
11	106-8680	1	Arm-Bypass	44	109-3278	1	Adapter-Straight
12	106-8681	1	Ring-Retaining, External	44:1	237-42	1	O-Ring
13	104-5304	1	Swashplate-Trunnion	45	126-3251	2	Tube-Charge
14	104-5313	1	Seal-Lip	46	114-8458	1	Spacer
15	114-8491	1	Washer	47	114-8459	1	Arm-Neutral, Right
16	104-5308	1	Spacer	48	106-8682	1	Screw-Sh
17	104-5310	1	Seal-Lip	49	115-8307	1	Spring-Extension
18	104-5309	1	Ring-Retaining	50	131-0908	1	Seal-Gerotor
19	109-2865	1	Bearing-Thrust	51	121-5745	1	Spacer
20	114-1689	1	Motor Cylinder Block Kit	52	109-3537	1	Seal Kit
21	94-6922	1	Bearing-Thrust	53	120-7982	1	RH Center Section Charge Kit
22	110-8561	1	Pump Block ASM	54	114-8464	1	Charge Relief Kit
23	104-5339	1	Washer-Flat	55	114-8465	1	Charge Kit
24	104-5340	1	Ring-Retaining	56	117-5361	1	Input Shaft Kit
25	126-0788	1	Gear-16T	57	126-2291	1	Control Arm Kit
26	114-1691	1	Shaft-Motor	58	114-8470	1	Axle Shaft Kit
27	104-5360	1	Washer	60	116-9705	1	Hub-Pulley
28	94-1933	2	Washer	61	116-9706	1	Fan
29	125-0000	1	Gear-43T	62	116-9707	1	Pulley
30	120-7974	1	Gear-11T	63	116-9708	1	Washer-Slotted
31	104-5329	1	Pin-Jackshaft	64	116-9714	1	Nut-HJ
32	104-2169	1	Ring-Retaining	99	135-3604	1	Brake Shaft Seal Kit ●
33	114-1694	1	Gear-54T				

● Not illustrated

LH Transaxle Assembly No. 135-1051

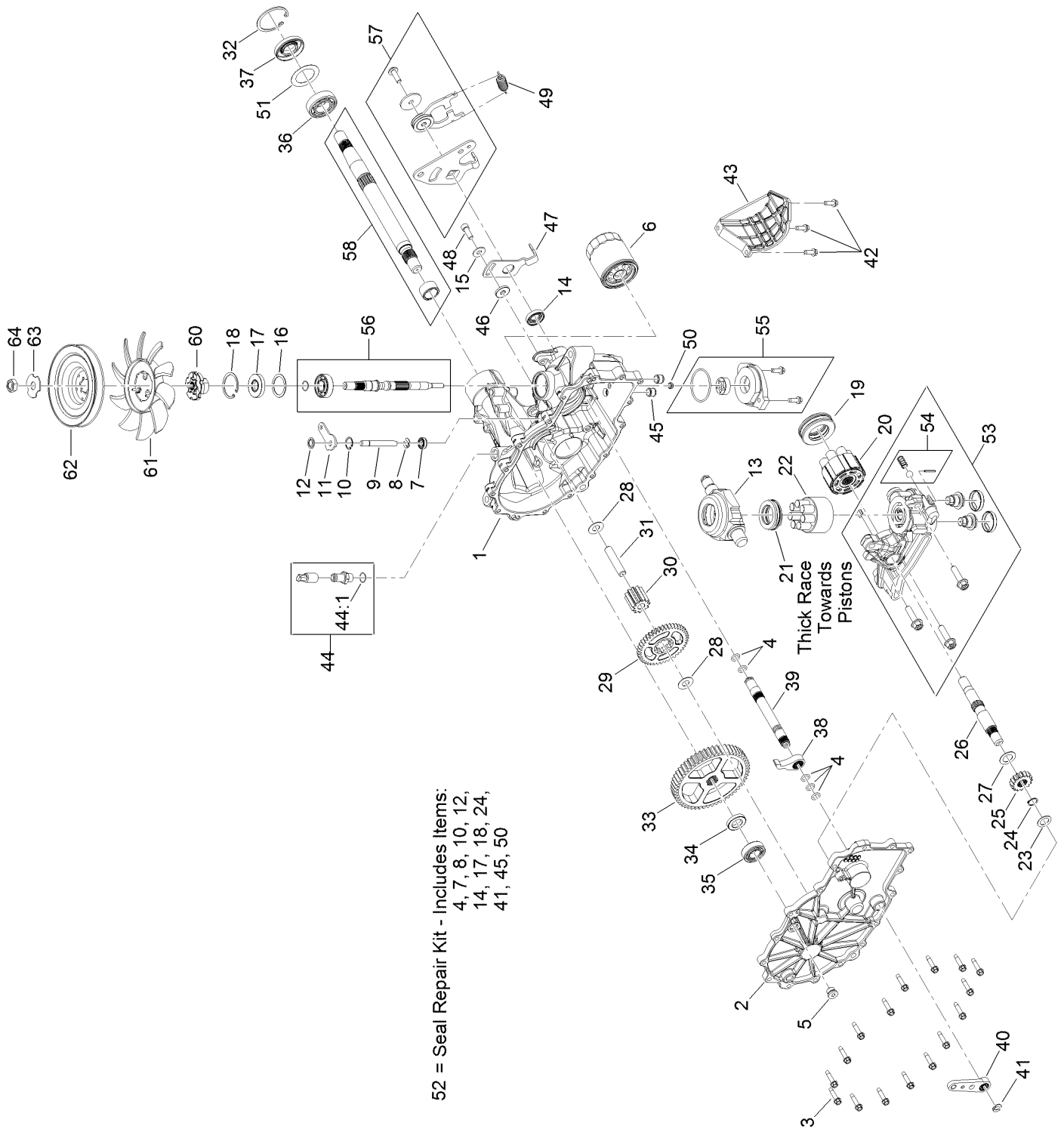

LH Transaxle Assembly No. 135-1051 (continued)

<i>Ref.</i>	<i>Part Number</i>	<i>Qty.</i>	<i>Description</i>	<i>Ref.</i>	<i>Part Number</i>	<i>Qty.</i>	<i>Description</i>
1	114-1676	1	Main Housing Kit	34	120-7975	1	Spacer
2	117-5358	1	RH Housing Side Kit	35	135-1361	1	Bearing-Ball
3	117-5359	16	Screw-HHF	36	120-7976	1	Bearing-Ball
4	114-1678	5	O-Ring	37	104-2144	1	Seal
5	135-1140	1	Plug-Straight	38	114-1697	1	Pawl-Brake
6	109-3321	1	Element-Oil Filter, HYD	39	114-1698	1	Shaft-Brake, Inboard
7	106-8676	1	Seal-Lip	40	125-0021	1	Handle-Brake
8	106-8677	1	Ring-Retaining, External	41	131-0906	1	Ring-Retaining, EXT
9	114-1685	1	Rod-Bypass	42	104-2120	3	Screw
10	106-8679	1	Ring-Retaining, Internal	43	120-7981	1	Guard-Filter, RH
11	106-8680	1	Arm-Bypass	44	109-3278	1	Adapter-Straight
12	106-8681	1	Ring-Retaining, External	44:1	237-42	1	O-Ring
13	104-5304	1	Swashplate-Trunnion	45	126-3251	2	Tube-Charge
14	104-5313	1	Seal-Lip	46	114-8458	1	Spacer
15	114-8491	1	Washer	47	114-8459	1	Arm-Neutral, Right
16	104-5308	1	Spacer	48	106-8682	1	Screw-Sh
17	104-5310	1	Seal-Lip	49	115-8307	1	Spring-Extension
18	104-5309	1	Ring-Retaining	50	131-0908	1	Seal-Gerotor
19	109-2865	1	Bearing-Thrust	51	121-5745	1	Spacer
20	114-1689	1	Motor Cylinder Block Kit	52	109-3537	1	Seal Kit
21	94-6922	1	Bearing-Thrust	53	120-7982	1	RH Center Section Charge Kit
22	110-8561	1	Pump Block ASM	54	114-8464	1	Charge Relief Kit
23	104-5339	1	Washer-Flat	55	114-8465	1	Charge Kit
24	104-5340	1	Ring-Retaining	56	117-5361	1	Input Shaft Kit
25	126-0788	1	Gear-16T	57	126-2291	1	Control Arm Kit
26	114-1691	1	Shaft-Motor	58	114-8470	1	Axle Shaft Kit
27	104-5360	1	Washer	60	116-9705	1	Hub-Pulley
28	94-1933	2	Washer	61	116-9706	1	Fan
29	125-0000	1	Gear-43T	62	116-9707	1	Pulley
30	120-7974	1	Gear-11T	63	116-9708	1	Washer-Slotted
31	104-5329	1	Pin-Jackshaft	64	116-9714	1	Nut-HJ
32	104-2169	1	Ring-Retaining	99	135-3604	1	Brake Shaft Seal Kit ●
33	114-1694	1	Gear-54T				

● Not illustrated

Axle and Bearing Assembly No. 116-9545

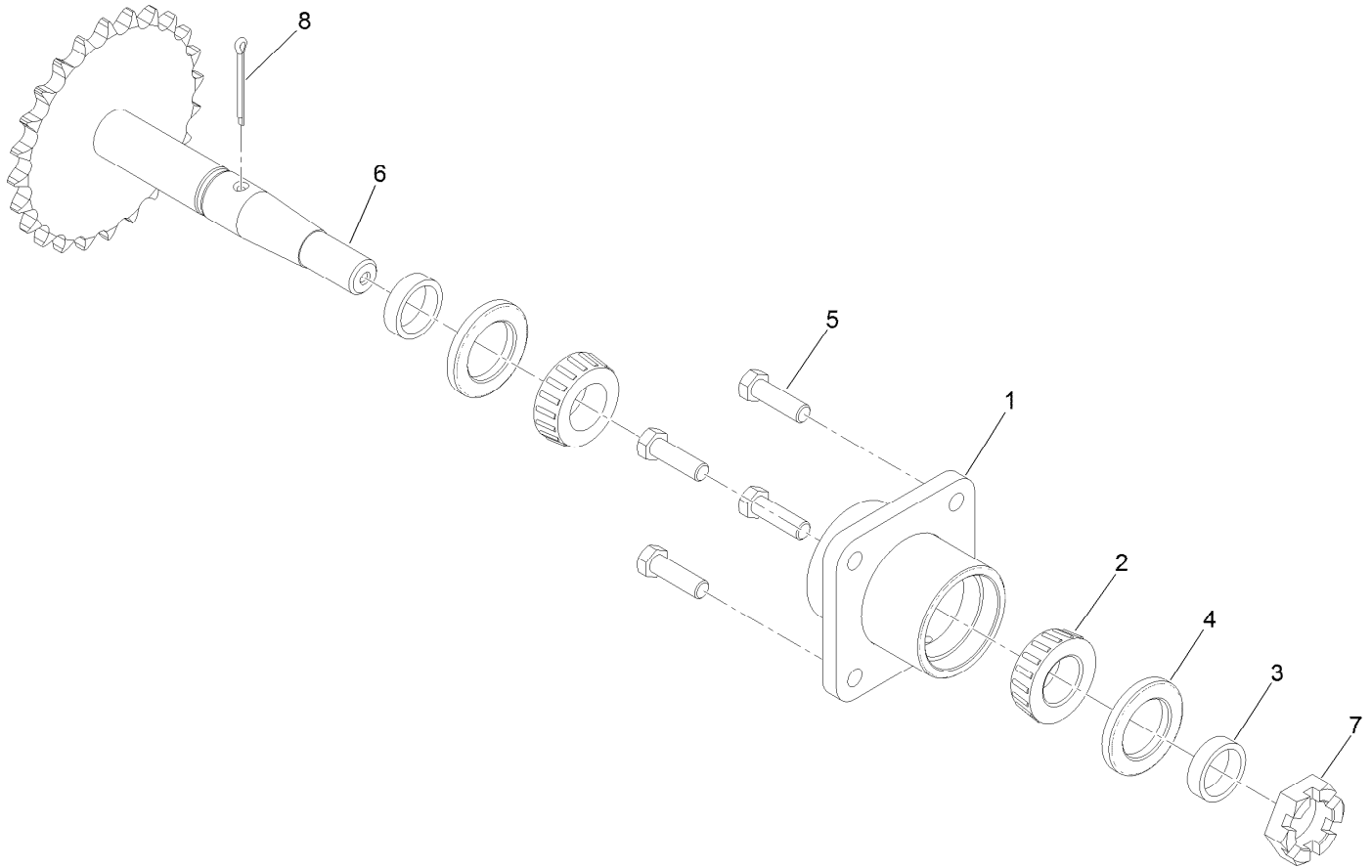

Axle and Bearing Assembly No. 116-9545 (continued)

<i>Ref.</i>	<i>Part Number</i>	<i>Qty.</i>	<i>Description</i>	<i>Ref.</i>	<i>Part Number</i>	<i>Qty.</i>	<i>Description</i>
1	116-6746-01	1	Mount-Bearing, Wheel	5	323-7	4	Screw-HH
2	1-543509	2	Bearing-Roller, Tapered	6	126-0459	1	Axle
3	116-6758	2	Spacer	7	99-3139	1	Nut-Slotted
4	1-543511	2	Seal-Grease	8	1-806800	1	Pin-Cotter

Tine Assembly

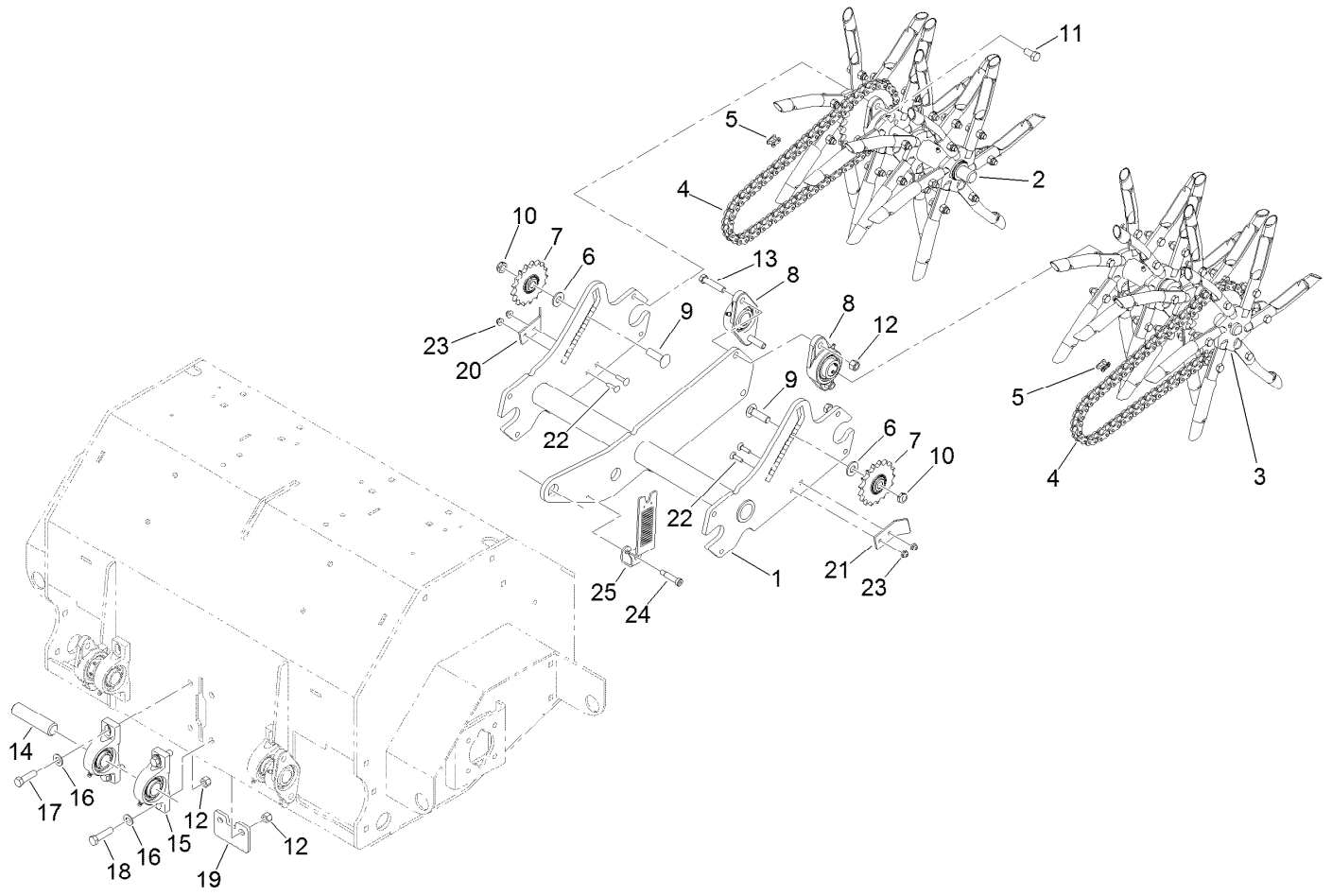

Tine Assembly (continued)

<i>Ref.</i>	<i>Part Number</i>	<i>Qty.</i>	<i>Description</i>	<i>Ref.</i>	<i>Part Number</i>	<i>Qty.</i>	<i>Description</i>
1	135-5952-03	1	Arm-Trail	14	116-6629	1	Shaft
2	135-2507	1	RH Tine Wheel ASM	15	116-6756	2	Bearing-Pillow Block ●
3	135-2510	1	LH Tine Wheel ASM	16	3256-25	4	Washer-Flat
4	126-8808	2	Chain-Roller	17	324-6	2	Screw-HH
5	116-6897	2	Link-Connecting	18	324-7	2	Screw-HH
6	87-7270	2	Washer-Thrust	19	116-7327-01	1	Plate-Downstop
7	126-9108	2	Sprocket-Idler, 15T	20	126-4192-03	1	Guard-Chain, RH
8	116-6777	2	Bearing-Flange, 2 Bolt	21	126-4193-03	1	Guard-Chain, LH
9	3233-14	2	Screw-CARR	22	3229-30	4	Screw-CARR
10	3296-45	2	Nut-Hex	23	104-7201	4	Nut-HF, NI
11	116-7109	4	Screw-HH ●	24	114-0239	1	Screw-HSH
12	3296-48	6	Nut-Hex	25	135-5109	1	Bracket-Control, Depth
13	324-8	2	Screw-HH				

● Use Pro-Lock, Nut Type (P/N 1-840022, .5ml tube) on threads.

RH Tine Wheel Assembly No. 135-2507

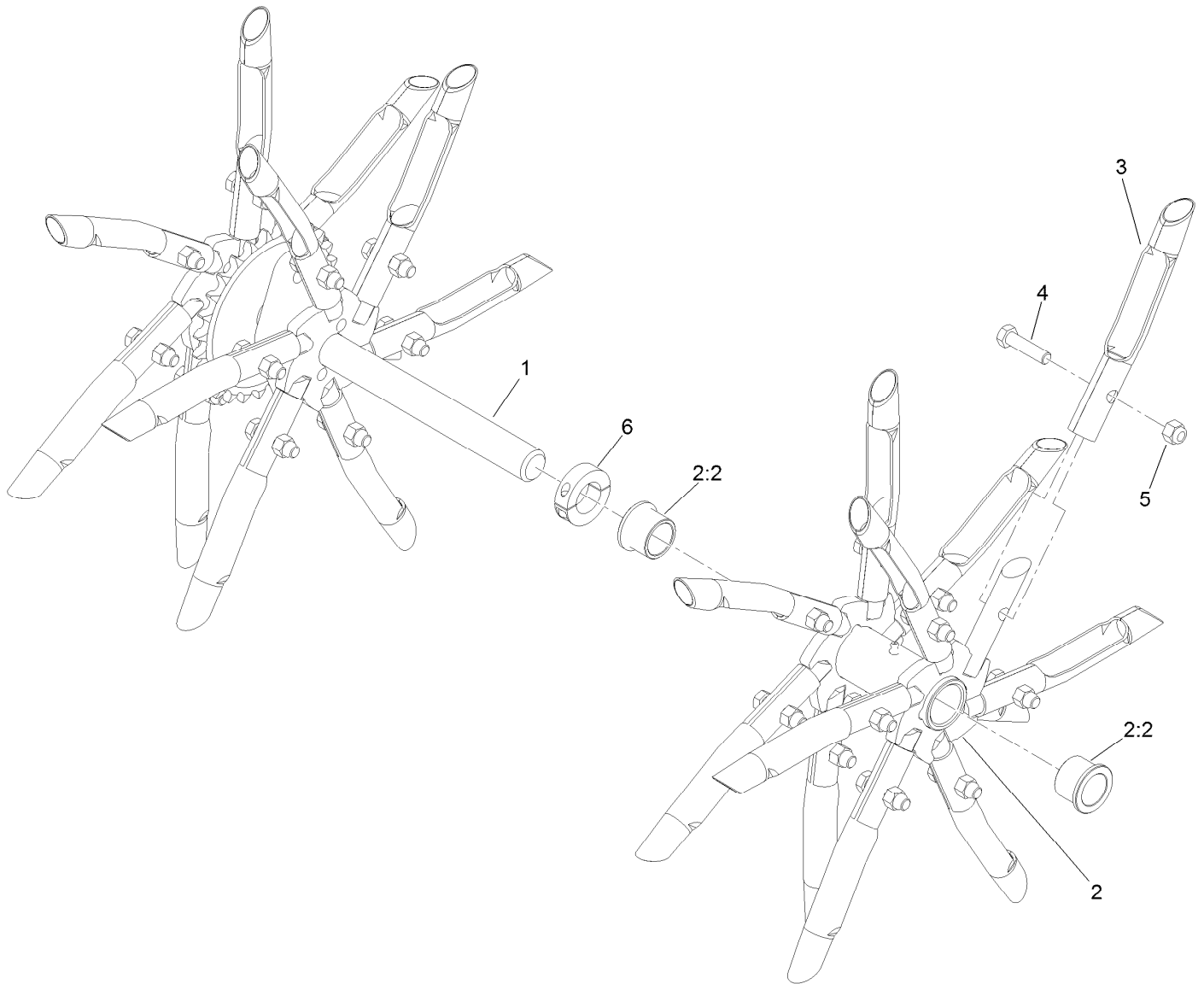

RH Tine Wheel Assembly No. 135-2507 (continued)

<i>Ref.</i>	<i>Part Number</i>	<i>Qty.</i>	<i>Description</i>	<i>Ref.</i>	<i>Part Number</i>	<i>Qty.</i>	<i>Description</i>
1	135-4341	1	Shaft-Tine, RH	4	323-8	24	Screw-HH
2	135-4342	1	Tine Shaft Float ASM	5	3296-39	24	Nut-Lock, NI
2:2	94-8949	2	Bushing-Flange	6	116-7271	1	Collar-Shaft, Split
3	126-2143	24	Tine-Coring (3/4 Inch)				

LH Tine Wheel Assembly No. 135-2510

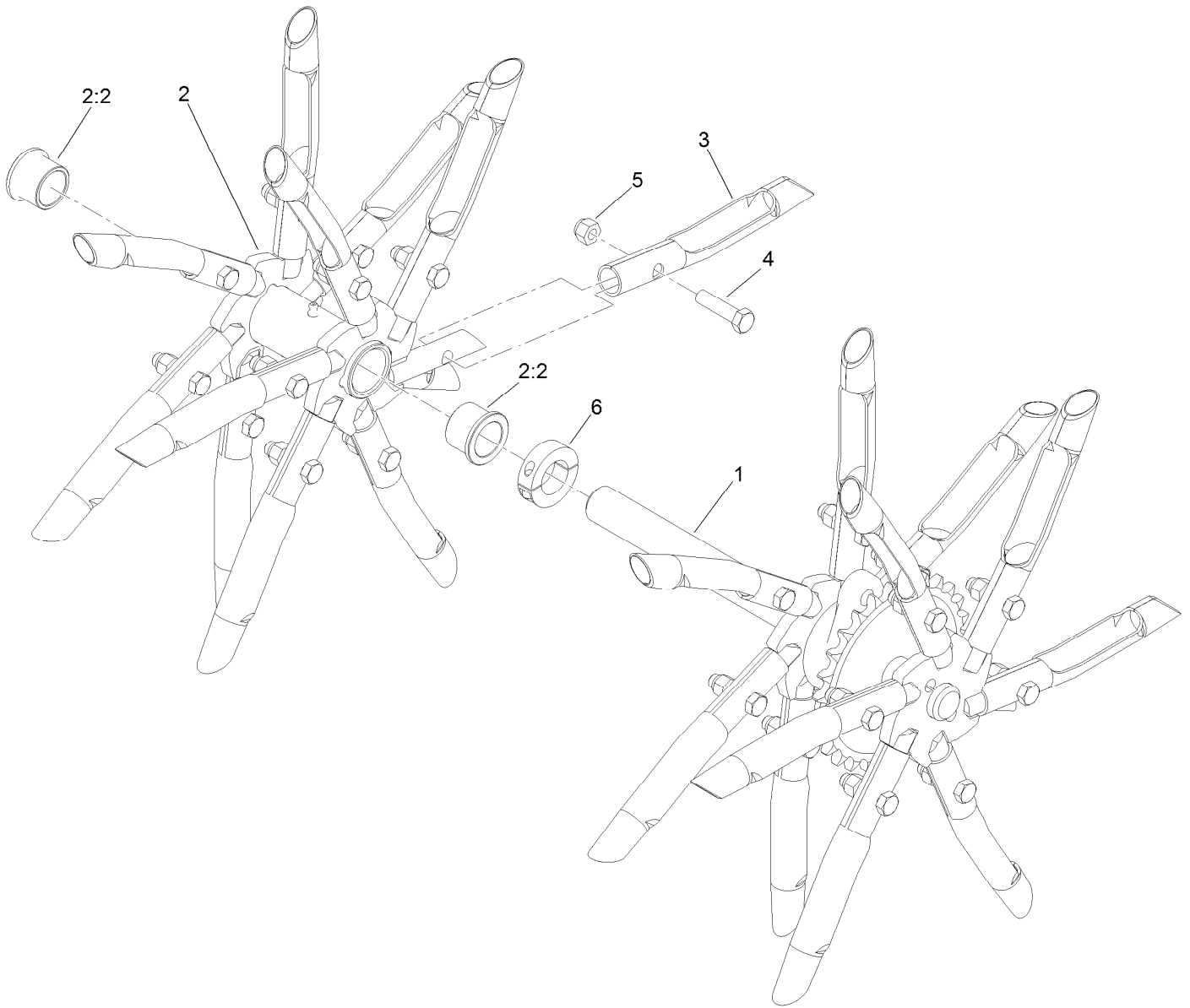

LH Tine Wheel Assembly No. 135-2510 (continued)

<i>Ref.</i>	<i>Part Number</i>	<i>Qty.</i>	<i>Description</i>
1	135-4343	1	Shaft-Tine, LH
2	135-4342	1	Tine Shaft Float ASM
2:2	94-8949	2	Bushing-Flange
3	126-2143	24	Tine-Coring (3/4 Inch)

<i>Ref.</i>	<i>Part Number</i>	<i>Qty.</i>	<i>Description</i>
4	323-8	24	Screw-HH
5	3296-39	24	Nut-Lock, NI
6	116-7271	1	Collar-Shaft, Split ●

● Use Loctite® 243 on threads.

Fuel Assembly

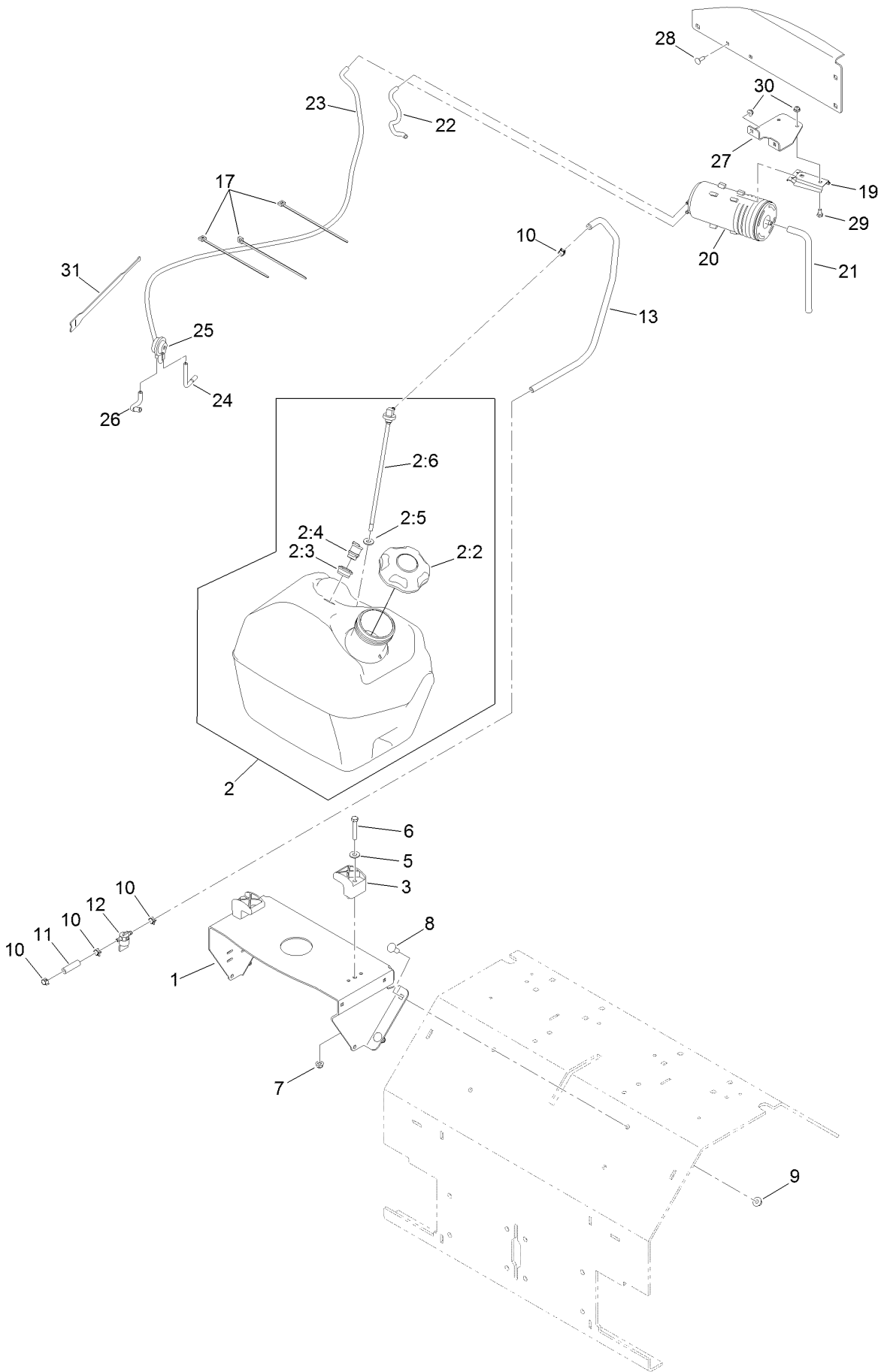

Fuel Assembly (continued)

<i>Ref.</i>	<i>Part Number</i>	<i>Qty.</i>	<i>Description</i>	<i>Ref.</i>	<i>Part Number</i>	<i>Qty.</i>	<i>Description</i>
1	116-9541-01	1	Support-Tank, Fuel	12	1-603770	1	Valve-Fuel
2	137-9502	1	Fuel Tank ASM	13	135-0494	1	Hose-Fuel
2:2	137-4119	1	Cap-Fuel, Ratcheting	17	1-303335	3	Tie-Plastic
2:3	114-0284	1	Grommet	19	114-0292	1	Bracket-Canister, Carbon
2:4	119-3547	1	Valve-Vent, Fuel	20	117-1221	1	Canister-Carbon, 800Cc
2:5	46-6560	1	Bushing	21	115-0962	1	Hose-Vent, Canister
2:6	109-9364	1	Fitting-Fuel (W/Line And Screen)	22	135-0986	1	Hose-Emissions
3	107-4543	2	Clamp	23	126-4179	1	Hose-Vent, Formed
5	3256-3	2	Washer-Flat	24	119-8501	1	Hose-Vent, Formed
6	322-10	2	Screw-HH	25	116-2232	1	Valve-Control, Vacuum
7	104-8300	2	Nut-HF, NI	26	119-8502	1	Hose-Vent, Formed
8	3231-22	4	Screw-CARR	27	126-2991-03	1	Bracket-Mounting, Canister
9	104-8301	4	Nut-HF, NI	28	3229-1	2	Screw-CARR
10	2412-98	4	Clamp-Hose	29	321-2	2	Screw-HH
11	119-7856	1	Hose-Fuel	30	104-7201	4	Nut-HF, NI
				31	116-2469	1	Strap-Velcro, Cable Tie

Motion Control Assembly

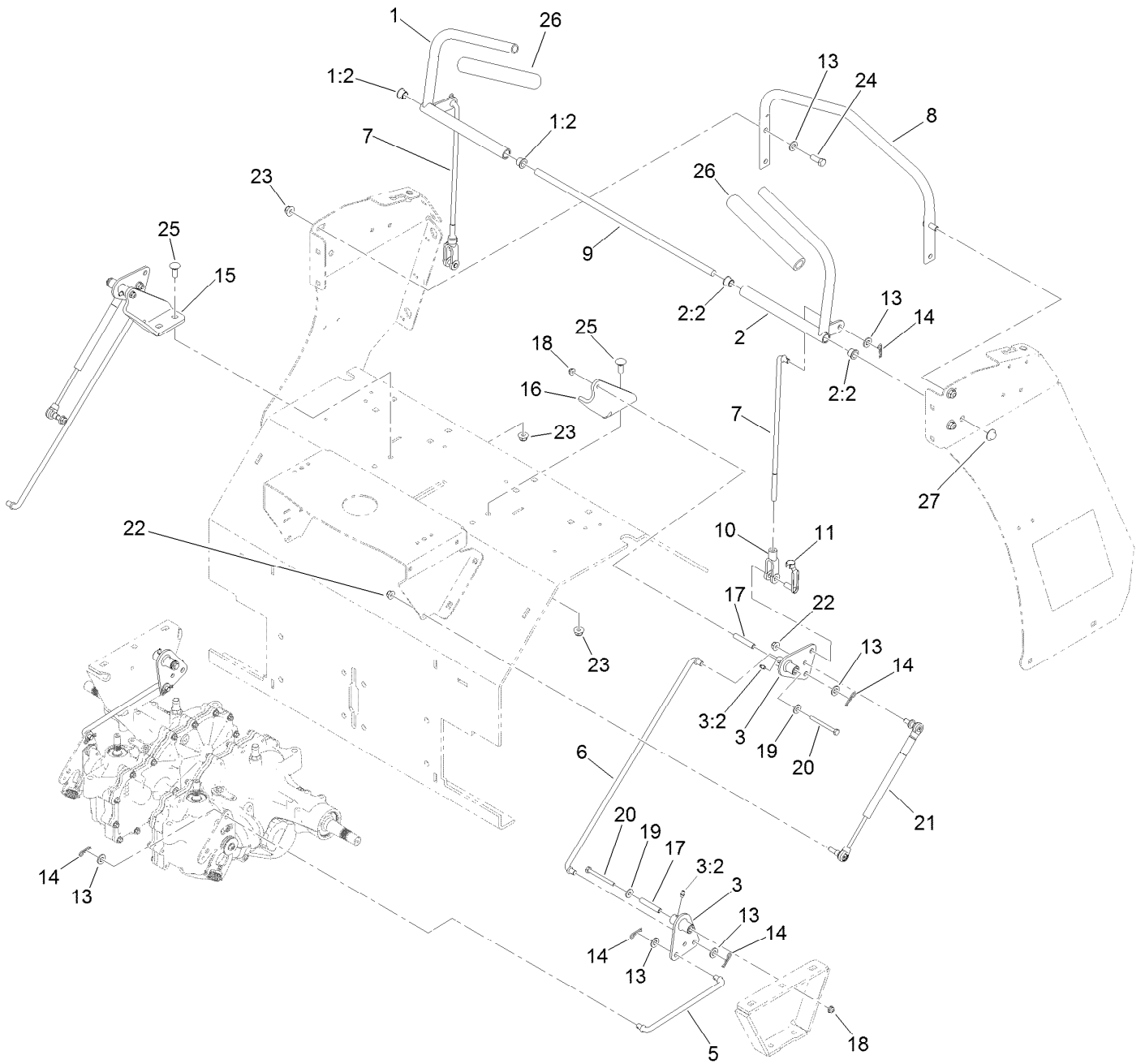

Motion Control Assembly (continued)

<i>Ref.</i>	<i>Part Number</i>	<i>Qty.</i>	<i>Description</i>	<i>Ref.</i>	<i>Part Number</i>	<i>Qty.</i>	<i>Description</i>
1	116-6567	1	RH Control Handle ASM	14	1-806003	10	Pin-Cotter
1:2	116-4279	2	Bearing-Flange	15	116-6576-03	1	Bracket-Pivot, RH
2	116-6566	1	LH Control Handle ASM	16	116-6577-03	1	Bracket-Pivot, LH
2:2	116-4279	2	Bearing-Flange	17	116-7224	4	Spacer
3	126-0340	4	Crank-Bell	18	104-7201	4	Nut-HF, NI
3:2	302-19	1	Fitting-Grease	19	3256-2	4	Washer-Flat
5	116-6722	2	Link-Control, Hydro	20	321-14	4	Screw-HH
6	116-9298	2	Link-Control, Bell Crank	21	116-0027	2	Damper-Control, Motion
7	116-6730	2	Link-Control, Bell Crank	22	104-8300	4	Nut-HF, NI
8	116-6608-03	1	Bar-Reference	23	104-8301	8	Nut-HF, NI
9	116-6607	1	Shaft-Pivot, Control	24	323-6	4	Screw-HH
10	1-633131	2	Yoke-Linkage, Brake	25	3231-2	4	Bolt-CARR
11	103-2399	2	Pin-Spring, Clevis	26	103-8153	2	Grip-Lever, Control
13	3256-24	14	Washer-Plain	27	32112-14	2	Nut-Push

Electrical Assembly

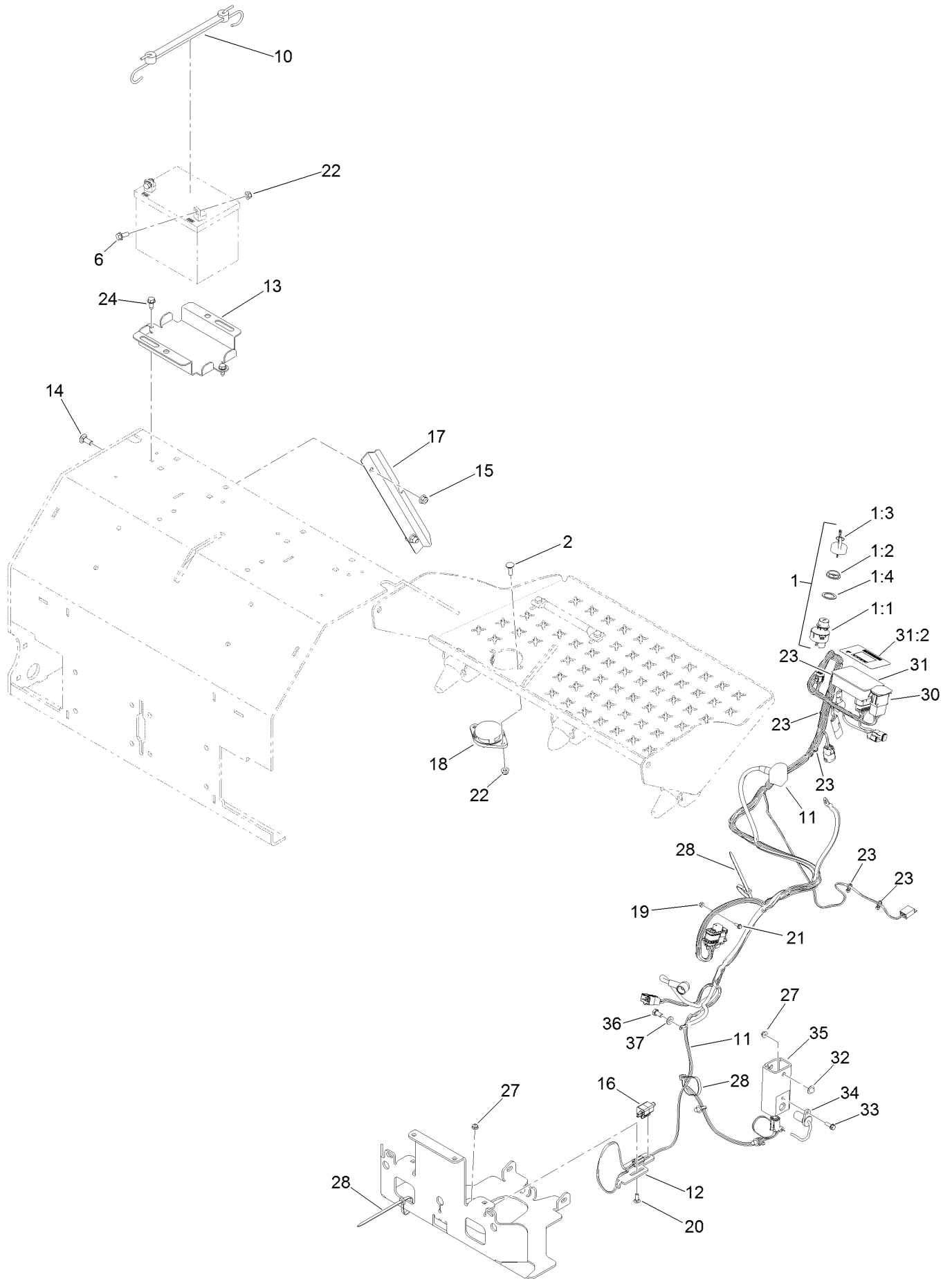

Electrical Assembly (continued)

<i>Ref.</i>	<i>Part Number</i>	<i>Qty.</i>	<i>Description</i>	<i>Ref.</i>	<i>Part Number</i>	<i>Qty.</i>	<i>Description</i>
1	126-6285	1	Ignition Switch ASM	20	3229-1	1	Screw-CARR
1:1		1	Switch-Ignition ●	21	3290-321	2	Screw-HWH
1:2	108-8660	1	Nut-Mounting	22	104-8300	4	Nut-HF, NI
1:3	106-5270	1	Ignition Key Set	23	1-303287	5	Tie-Cable
1:4	108-8659	1	Washer-Backup	24	32144-70	2	Screw-HWHTF
2	3230-2	2	Bolt-CARR	27	104-7201	2	Nut-HF, NI
6	3234-5	2	Screw-HHF	28	1-303335	5	Tie-Plastic
10	104-2466	1	Holddown-Battery	30	100-1535	1	Switch-Rocker, (On)-Off-(On)
11	135-5919	1	Harness-Wire ■	31	135-2500	1	Hour Meter ASM
12	116-7589	1	Mount-Switch	31:2	135-1854	1	Decal-Meter, Hour
13	116-9383-03	1	Bracket-Battery	32	3290-320	1	Nut-Push
14	3231-2	2	Bolt-CARR	33	32105-15	1	Screw-HWH
15	104-8301	2	Nut-HF, NI	34	135-4381	1	Sensor, Quadrature
16	110-6765	1	Switch	35	135-6609	1	Housing-Depth Control 30
17	116-9394-03	1	Guard-Harness	36	33114-016	1	Screw-HH
18	92-6282	1	Switch-Seat	37	33094-00	1	Washer-Plain
19	3296-2	2	Nut-Lock, NI				

● Not serviced separately

■ Use dielectric grease on all unsealed connectors and terminals only. Do not apply in sealed connectors.

Auxiliary Hydraulic Assembly

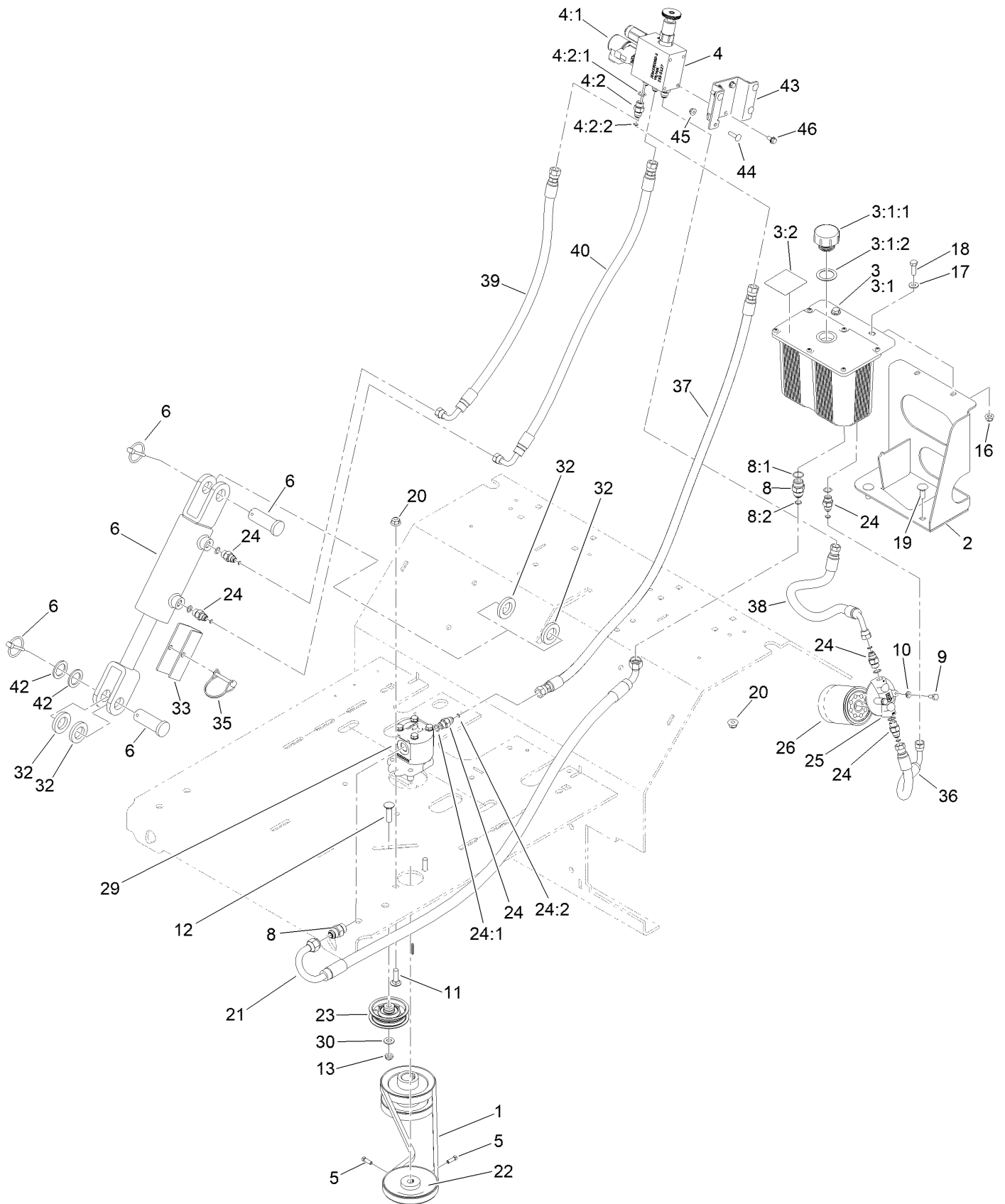

Auxiliary Hydraulic Assembly (continued)

<i>Ref.</i>	<i>Part Number</i>	<i>Qty.</i>	<i>Description</i>	<i>Ref.</i>	<i>Part Number</i>	<i>Qty.</i>	<i>Description</i>
1	116-8874	1	Belt-4L Section	20	104-8301	6	Nut-HF, NI
2	116-6618-03	1	Bracket-Tank, Hydraulic	21	116-9309	1	Hose-Hydraulic
3	116-7557	1	Reservoir ASM	22	116-6667	1	Pulley
3:1		1	Tank-Hydraulic ●	23	116-6760	1	Pulley-Idler, Flat
3:1:1	103-1948	1	Cap-Reservoir, HYD	24	103-2156	6	Fitting-Straight
3:1:2	103-1949	1	Gasket-Cap	24:1	1-603921	1	O-Ring
3:2	115-4212	1	Decal-Warning	24:2	103-1020	1	O-Ring
4	135-5127	1	Manifold ASM	25	104-7836	1	Head-Filter
4:1	112-0197	2	E Coil-12V DC	26	1-633750	1	Filter-Oil, HYD
4:2	103-2156	4	Fitting-Straight	29	116-9129	1	Hydraulic Pump ASM
4:2:1	1-603921	1	O-Ring	30	3256-24	1	Washer-Plain
4:2:2	103-1020	1	O-Ring	32	116-6781	4	Spacer
5	3241-6	2	Screw-SQH ■	33	116-7307-01	1	Stop-Cylinder
6	116-6969	1	HYD Cylinder ASM	35	100-1663	1	Pin-Hitch
8	1-603990	2	Fitting-Straight	36	116-6675	1	Hose-Hydraulic, LP
8:1	1-603920	1	O-Ring	37	116-8151	1	Hose-Hydraulic
8:2	1-603992	1	O-Ring	38	116-9308	1	Hose-Hydraulic
9	321-3	2	Screw-HH	39	116-6677	1	Hose-Hydraulic
10	1-805004	2	Washer-Lock	40	135-5973	1	Hydraulic Hose ASM
11	3231-25	2	Bolt-CARR	42	3-8514	2	Washer-Thrust
12	3231-4	1	Screw-CARR	43	135-3603-03	1	Bracket-Sensor, Control (Depth)
13	3296-59	1	Nut-Lock, NI	44	3229-1	4	Screw-CARR
16	104-8300	2	Nut-HF, NI	45	104-7201	4	Nut-HF, NI
17	3256-2	2	Washer-Flat	46	119-1065	4	Screw-Lock, HF
18	322-5	2	Screw-HH				
19	3231-2	4	Bolt-CARR				

● Not serviced separately

■ Use Pro-Lock, Nut Type (P/N 1-840022, .5ml tube) on threads.

Hydraulic Cylinder Assembly No. 116-6969

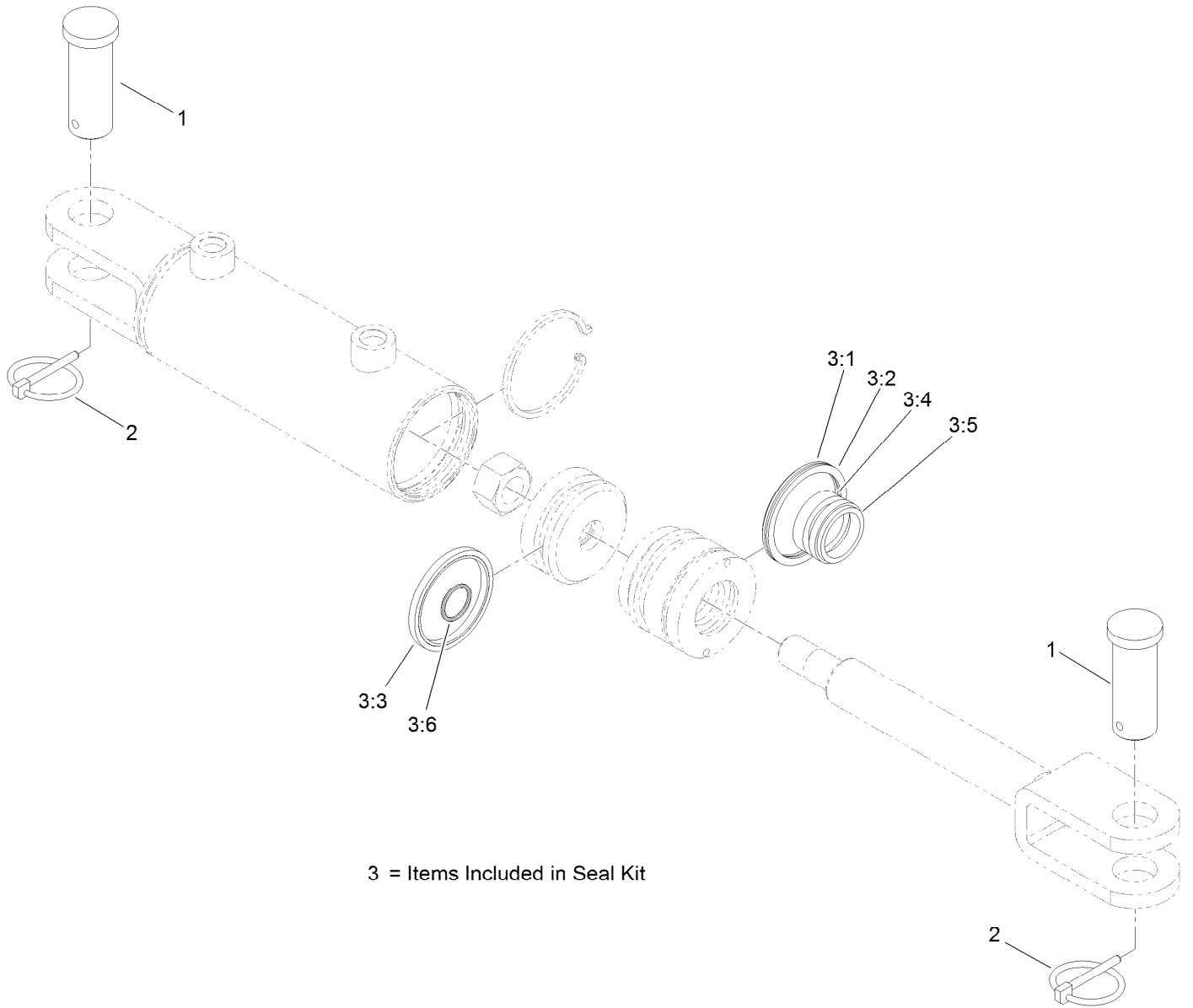

3 = Items Included in Seal Kit

Hydraulic Cylinder Assembly No. 116-6969 (continued)

<i>Ref.</i>	<i>Part Number</i>	<i>Qty.</i>	<i>Description</i>	<i>Ref.</i>	<i>Part Number</i>	<i>Qty.</i>	<i>Description</i>
1	116-7290	2	Pin-Clevis	3:3		1	Psp Seal ●
2	92-1298	2	Pin-Lynch	3:4		1	Bs Seal ●
3	127-3234	1	Seal Kit	3:5		1	Dust Seal ●
3:1		1	O-Ring ●	3:6		1	O-Ring ●
3:2		1	Backup Ring ●				

● Not serviced separately

Hydraulic Pump Assembly No. 116-9129

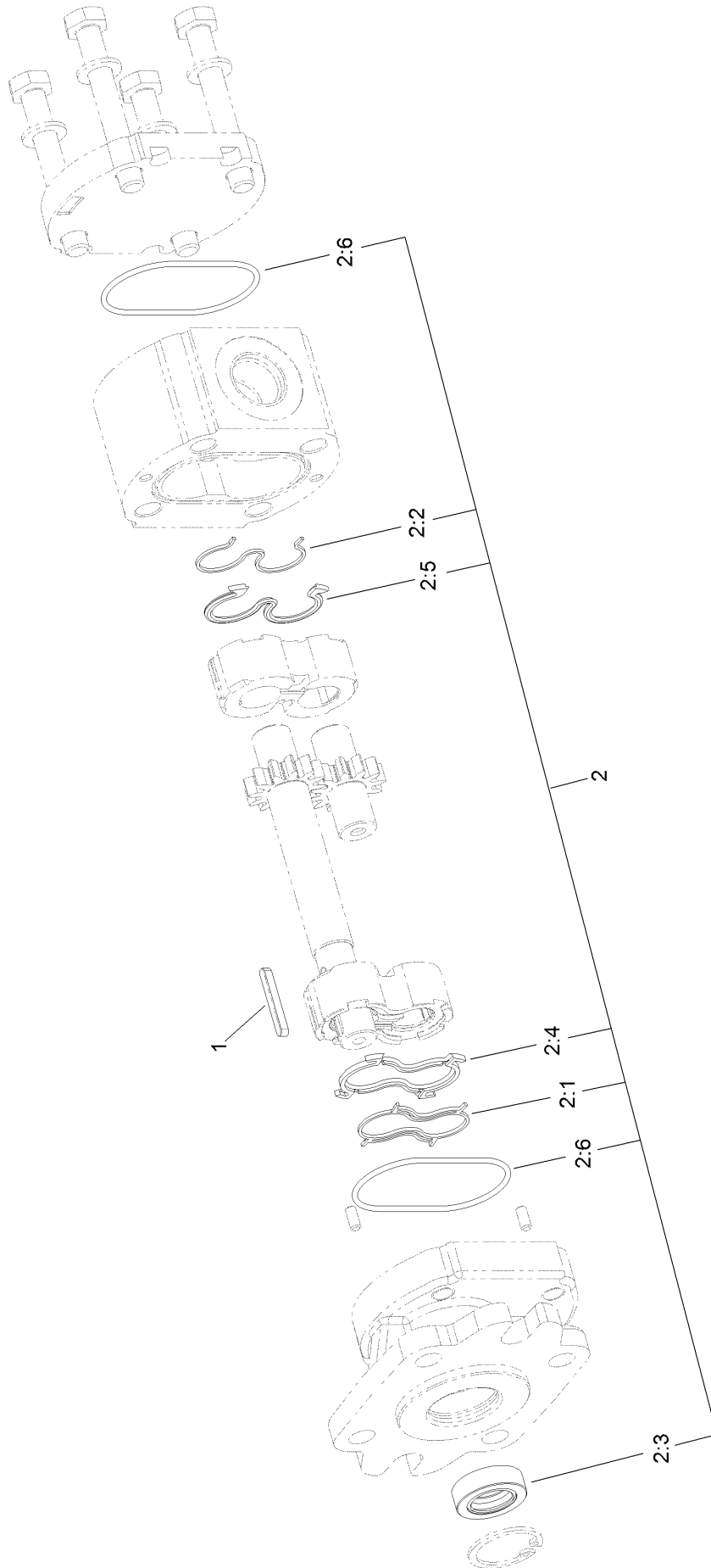

Hydraulic Pump Assembly No. 116-9129 (continued)

<i>Ref.</i>	<i>Part Number</i>	<i>Qty.</i>	<i>Description</i>	<i>Ref.</i>	<i>Part Number</i>	<i>Qty.</i>	<i>Description</i>
1	115-7855	1	Key-Square	2:3		1	Seal-Shaft ●
2	112-0199	1	Seal Kit	2:4		1	Seal-Upper ●
2:1		1	Seal-Anti Extrusion ●	2:5		1	Seal ●
2:2		1	Seal-Anti Extrusion ●	2:6		2	O-Ring ●

● Not serviced separately

Engine Assembly

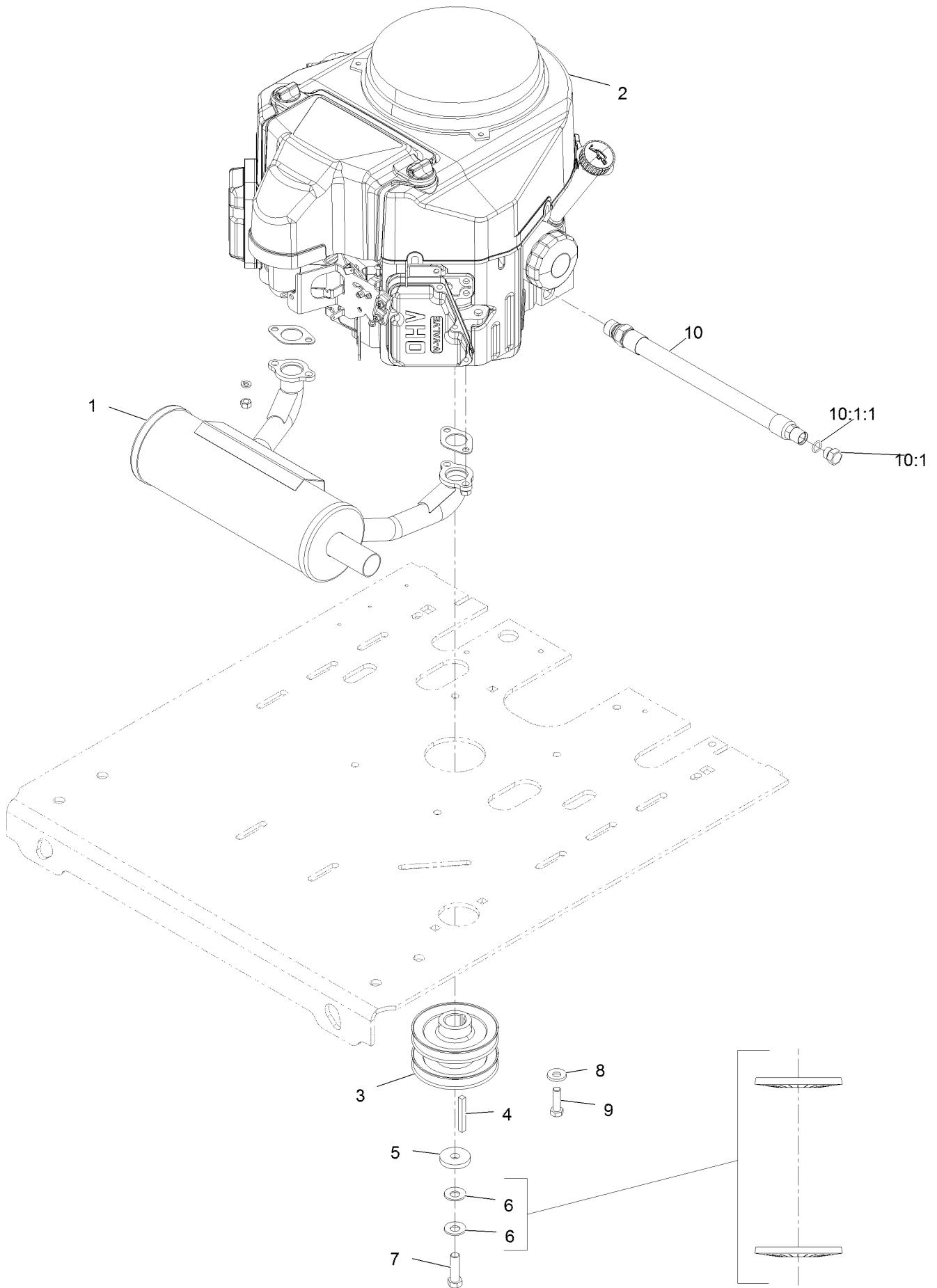

Engine Assembly (continued)

<i>Ref.</i>	<i>Part Number</i>	<i>Qty.</i>	<i>Description</i>	<i>Ref.</i>	<i>Part Number</i>	<i>Qty.</i>	<i>Description</i>
1	116-3735	1	Muffler-Horizontal	8	98-5975	4	Washer-Belleville
2		1	Engine-Kawasaki, Fs541 ■▲	9	323-7	4	Screw-HH
3	116-9709	1	Pulley	10	116-4924	1	Engine Oil Drain Hose ASM
4	103-4177	1	Key				◆
5	1-543610	1	Washer-Flat	10:1	353-508	1	Plug-HH ●
6	1-603610	2	Washer-Spring	10:1:1	237-42	1	O-Ring
7	109-9761	1	Screw-HH □				

● Torque to 24-26 ft-lb

▲ Obtain parts from www.kawpower.com

◆ Use a Teflon Pipe Sealant or equivalent on threads.

□ Use Pro-Lock, Nut Type (P/N 1-840022, .5ml tube) on threads.

■ Not serviced separately

Attachments and Accessories

For 39521 30in Stand-On Aerator

Product Name

Model/Part

Spreader Hopper ASM 33525

Notes:

Notes:

Notes:



Count on it.