



MODEL NO. 41107-210000101 and UP

**OPERATOR'S &
SETUP
MANUAL**
**MULTI PRO® 1200
TURF SPRAYER**

To assure maximum safety, optimum performance, and to gain knowledge of the product, it is essential that you or any other operator of this vehicle read and understand the contents of this manual before the engine is ever started. Pay particular attention to the **SAFETY INSTRUCTIONS** highlighted by the triangular safety alert symbol.

 The safety alert symbol means **CAUTION, WARNING, or DANGER** - personal safety instruction. Failure to comply with the instruction may result in personal injury.



IDENTIFICATION AND ORDERING

VEHICLE:

The MULTI PRO® 1200 has two identification numbers: a model number and a serial number. These numbers are stamped into a plate located on floor board of the vehicle. In any correspondence concerning the unit, supply the model number and serial number to ensure correct information and replacement parts are obtained. Record your Vehicle Identification numbers on the illustration below for future reference.

MOD.	
SER.	
THE TORO CO. MINNEAPOLIS, MN. 55420	

ENGINE:

The engine has three identification numbers: a model number, a specification number and a serial number. These numbers appear on a decal affixed to the engine shrouding. When ordering parts or in any communication involving the engine, it will be necessary to supply the engine manufacturer with these numbers, to ensure correct information and replacement parts are obtained. Record the engine identification numbers on the illustration below for future reference.

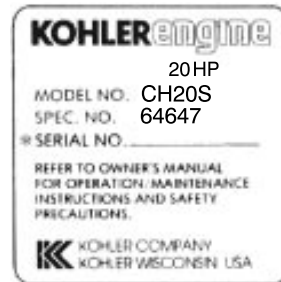

1506

DATE PURCHASED: _____

This vehicle is not a motor vehicle as defined by the National Traffic Motor Vehicle Safety Act. **It is not designed or manufactured for use on roads, streets, or highways, and is not to be licensed as a motor vehicle.**

▲ WARNING
The engine exhaust from this product contains chemicals known to the State of California to cause cancer, birth defects, or other reproductive harm.

FOREWORD

You have purchased a vehicle from the industry leader in maintenance excellence. Its future performance and dependability are of prime importance. TORO is also concerned about future use of the vehicle and safety of the user. Therefore, this manual must be read by you and those involved with the MULTI PRO® 1200 to assure that safety, proper setup, operation, and maintenance procedures are followed at all times. The major sections of the manual are:

1. SAFETY INSTRUCTIONS
2. SETUP INSTRUCTIONS
3. BEFORE OPERATING
4. OPERATING INSTRUCTIONS
5. MAINTENANCE
6. SPRAYING SYSTEM

Safety, mechanical, and some general information in this manual are emphasized. **DANGER, WARNING, and CAUTION** identify safety messages. Whenever the triangle safety symbol appears, it is followed by a safety message that must be read and understood. For more details concerning safety, read the safety instructions on pages 4 through 6. **IMPORTANT** identifies special mechanical information and **NOTE** identifies general information worthy of special attention.

SPARK ARRESTER

In some places a Spark Arrester muffler must be used because of local, state, or federal regulations. The Spark Arrester available from your local TORO Distributor is approved by the United States Department of Agriculture and the United States Forest Service.

When the machine is used or operated on any California forest, brush, or grass covered land, a properly operating Spark Arrester must be obtained and installed to the Muffler. The operator is violating state law, Section 4442 Public Resources Code if a Spark Arrester is not used.

All information, illustrations and specifications in this manual are based on the latest product information available at the time of publication. The right is reserved to make any changes at any time without notice.

TABLE OF CONTENTS

DESCRIPTION	PAGE
SAFETY INSTRUCTIONS	5-6
SUPERVISOR'S RESPONSIBILITIES.....	5
BEFORE OPERATING.....	5-6
WHILE OPERATING.....	6-7
SAFETY AND INSTRUCTIONS	7
MAINTENANCE.....	7
SAFETY AND INSTRUCTION DECALS	8-9
SPECIFICATIONS	10
SETUP INSTRUCTIONS	11-14
ACTIVATE AND CHARGE BATTERY.....	11
SPRAY SYSTEM.....	12-14
BEFORE OPERATING	15-19
CHECK ENGINE CRANKCASE OIL.....	15
FILL FUEL TANK.....	16
CHECK AIR CLEANER/AIR INTAKE.....	17
CHECK TRANSAXLE/HYDRAULIC FLUID.....	18
CHECK BRAKE FLUID/MASTER CYLINDER.....	18
CHECK TORQUE OF WHEEL NUTS.....	19
CHECK TIRE PRESSURE.....	19
INSPECT TIRES.....	19
NEUTRAL SWITCH.....	19
VEHICLE CONTROLS	20-21
OPERATING INSTRUCTIONS	22-25
PRE-STARTING CHECKS.....	22
STARTING ENGINE.....	22
DRIVING VEHICLE.....	22
STOPPING VEHICLE.....	23
NEW VEHICLE BREAK-IN.....	23
OPERATING CHARACTERISTICS.....	23-24
SPEED.....	24
TURNING.....	24
BRAKING.....	24
TIPOVERS.....	24
HILLS.....	25
TOWING VEHICLE.....	25
MAINTENANCE	26
SERVICE INTERVAL CHART.....	26
DAILY MAINTENANCE SCHEDULE.....	27
MAINTENANCE SCHEDULE.....	28
JACKING VEHICLE.....	29
NEUTRAL SWITCH.....	29-30
LUBRICATION	31-32
AIR CLEANER MAINTENANCE	33
ENGINE MAINTENANCE	34-37
AIR INTAKE/COOLING AREAS.....	34
ENGINE CRANKCASE OIL.....	34
OIL FILTER.....	35
IGNITION SYSTEM.....	35
SPARK PLUG.....	36
IN-LINE FUEL FILTER.....	37
CLUTCH SYSTEM AND CVT BELT.....	38
STEERING PUMP BELT TENSION.....	38

TABLE OF CONTENTS

DESCRIPTION	PAGE
HYDRAULIC SYSTEM MAINTENANCE	39-40
CHANGING TRANSAXLE/HYDRAULIC FLUID.....	39
REPLACING TRANSAXLE/HYDRAULIC FILTER.....	39
CHECKING HYDRAULIC LINES AND HOSES.....	40
CLEANING TRANSAXLE/HYDRAULIC STRAINER.....	40
PRESSURE SETTINGS.....	40
TRANSAXLE MAINTENANCE	41
HYDRAULIC SYSTEM DIAGRAM	41
TIRE & BRAKE MAINTENANCE	42
ELECTRICAL MAINTENANCE	43-44
JUMP STARTING PROCEDURE.....	43
FUSES.....	43
BATTERY CARE & STORAGE.....	44
VEHICLE ELECTRICAL DIAGRAM	45
SPRAYING SYSTEM	47
CONTROLS AND OPERATION	48-49
QUICK START SPRAY GUIDE.....	49
BEFORE SPRAYING	50-58
SPRAY PRO™ CONSOLE FUNCTIONS	59
SPRAY PRO™ SET-UP	60-62
SPRAY PRO™ CALIBRATION	61
SPRAYER CALIBRATION	63
SPRAYER OPERATION	64
PREVENTIVE MAINTENANCE	65
SUCTION STRAINER.....	65
AFTER SPRAYING.....	65
FLUSH PUMP AFTER USE.....	65
PUMP MAINTENANCE	66
CHANGING OF VALVES AND DIAPHRAGMS.....	66
VALVES.....	66
DIAPHRAGM.....	66
PUMP LUBRICATION.....	66
SUCTION AND PRESSURE DAMPENER MAINTENANCE.....	66
MAINTENANCE	67-68
BOOM BYPASS VALVE.....	67
FLOWMETER.....	68
BOOM CONTROL VALVE.....	68
SPRAY SYSTEM FLOW & ELECTRICAL DIAGRAM	69-70
TROUBLESHOOTING	71-73
STORAGE	74
PERFORMANCE VERIFICATION	75
SET-UP SPRAY SYSTEM	75
RATE CHECK	75-76
CALCULATE RANGE	76
TORO® WARRANTY	BACK COVER

SAFETY INSTRUCTIONS

The MULTI PRO® 1200 Turf Sprayer was designed and tested to offer safe service when operated and maintained properly. Although hazard control and accident prevention partially are dependent upon the design and configuration of the vehicle, these factors are also dependent upon the awareness, concern, and proper training of the personnel involved in the operation, maintenance, and storage of the vehicle. Improper use or maintenance of the vehicle can result in injury or death.

This is a specialized Turf Sprayer designed for off road use. Its ride and handling will have a different feel than what drivers experience with passenger cars or trucks. So take time to become familiar with your MULTI PRO® 1200. The attachments that adapt to the MULTI PRO® 1200 are not covered in this manual. See the specific Operator's Manual provided with the attachment for additional safety instructions. **READ THESE MANUALS.**

TO REDUCE THE POTENTIAL FOR INJURY OR DEATH, COMPLY WITH THE FOLLOWING SAFETY INSTRUCTIONS:

SUPERVISOR'S RESPONSIBILITIES:

1. Make sure operators are thoroughly trained and familiar with the Operator's Manual and all labels on the vehicle.
2. Be sure to establish your own special procedures and work rules for unusual operating conditions (e.g. slopes too steep for vehicle operation).

BEFORE OPERATING:

3. Operate the vehicle only after reading and understanding the contents of this manual. A replacement manual is available by sending complete model and serial number to: **Hahn Equipment Co.**, A subsidiary of The TORO Company, 1625 N. Garvin, Evansville, Indiana 47711-4596.

Read and understand the Engine Manufacturer's Operator's Manual. Follow the safety alert messages.

4. **Never** allow children to operate the vehicle or adults to operate it without proper instructions. Only trained and authorized persons should operate this vehicle. Anyone who operates the vehicle should have a motor vehicle license.

5. This vehicle is designed to carry **Only You, the Operator**. **Never** carry passengers on the vehicle.

6. **Never** operate the vehicle when under the influence of drugs or alcohol.

7. Become familiar with the controls and know how to stop the engine quickly.

8. Keep all shields, safety devices, and decals in place. If a shield, safety device, or decal is malfunctioning, illegible, or damaged, repair or replace it before operating the vehicle.

9. Always wear substantial shoes. Do not operate vehicle while wearing sandals, tennis shoes, or sneakers. Do not wear loose fitting clothing or jewelry which could get caught in moving parts and cause personal injury.

10. Wearing safety glasses, safety shoes, long pants, and a helmet is advisable and required by some local safety and insurance regulations.

11. Keep everyone, especially children and pets, away from the areas of operation.

12. Before operating the vehicle, always check all parts of the vehicle and any attachments. If something is wrong, **stop using the vehicle**. Make sure the problem is corrected before vehicle or attachment is operated again.

13. Since gasoline is highly flammable, handle it carefully.

A. Use an approved gasoline container.

B. Do not remove cap from fuel tank when engine is hot or running.

C. Do not smoke while handling gasoline.

D. Fill fuel tank outdoors and to approximately one inch below top of tank, (bottom of filler neck). Do not overfill.

SAFETY INSTRUCTIONS

E. Wipe up any spilled gasoline.

14. The MULTI PRO® 1200 is equipped with a Neutral Switch. The purpose of this switch is to insure that the vehicle will **not** start unless the Range Selector is in the NEUTRAL position and/or the Neutral Accelerator Lock will not engage unless the Range Selector is in the neutral position. Should any of the following occur:

A. Vehicle will not start with Range Selector in neutral.

B. Vehicle will start with Range Selector in gear.

C. Neutral Accelerator Lock will engage with Range Selector in gear.

D. Neutral Accelerator Lock will not engage with Range Selector in neutral.

See the Maintenance section for the Neutral Switch, page 29.

WHILE OPERATING:

WARNING: Do not run engine in a confined area without adequate ventilation. Exhaust fumes are hazardous, and could possibly be deadly.

15. Operator should remain seated whenever the vehicle is in motion. Operator should keep both hands on steering wheel whenever possible. Keep arms and legs within the vehicle body at all times.

16. Sit on seat when starting and operating the vehicle.

17. When starting the engine:

A. Engage the Parking Brake.

B. Turn Key Switch to the "ON" position.

C. Apply Service Brake.

D. Put the Range Selector in the Neutral Position and start the engine.

E. After engine is started, select the appropriate range.

F. Release the Parking Brake.

18. Operator must be skilled and trained in how to drive on hillsides. Failure to use caution on slopes or hills may cause loss of control and vehicle to tip or roll, possibly resulting in personal injury or death.

19. The vehicle is designed with safety in mind. This vehicle is not a passenger car. It is a Turf Sprayer and is not designed for use on roadways. Above all, use good judgement when operating this vehicle. Failure to operate vehicle safely may result in an accident, tip over of vehicle and serious injury or death. Drive carefully. To prevent tipping or loss of control:

A. Use extreme caution, reduce speed and maintain a safe distance around sand traps, ditches, creeks, ramps, and any unfamiliar areas, or other hazards.

B. Watch for holes or other hidden hazards.

C. Always reduce speed before starting up or down a hill. Do not start or stop suddenly when traveling uphill or downhill. Do not operate vehicle on a **steep** slope. Travel straight up and down normal slopes. Avoid turning on hillsides whenever possible. Reduce speed when making sharp turns or when turning on hillsides.

D. If engine stalls or loses power and cannot make it to the top of a slope, apply brakes and do not turn vehicle around. Always back slowly straight down the slope.

E. Use extra caution when operating vehicle on wet surfaces, at higher speeds or with a full load. Stopping time will increase with a full load.

F. Operate vehicle with extra caution when handling off-center loads that cannot be centered.

G. Avoid sudden starts and stops. Do not go from reverse to forward or forward to reverse without first coming to a complete stop.

H. Do not attempt sharp turns or abrupt maneuvers or other unsafe driving actions that may cause a loss of vehicle control.

I. Before backing up, be sure no one is behind the vehicle. Back up slowly.

J. Watch out for traffic when near or crossing roads. Always yield the right of way to pedestrians and other vehicles. This vehicle is **not** designed for use on streets or highways. Always signal your turns and stops early enough to let other people know what you plan to do. Obey all traffic rules and regulations.

K. Never operate vehicle in or near an area where dust or fumes, which are explosive, are in the air. The electrical and exhaust systems of the vehicle can produce sparks capable of igniting explosive materials.

SAFETY AND INSTRUCTIONS

L. Watch out for and avoid low overhangs such as tree limbs, door jambs, overhead walkways, etc. Make sure there is enough room overhead to easily clear the vehicle and your head.

M. If ever unsure about safe operation, STOP WORK and ask your supervisor.

20. Do not touch Engine, Muffler, or Muffler Shield while engine is running or soon after it has stopped because these areas may be hot enough to cause burns.

21. If the vehicle ever vibrates abnormally, stop immediately, turn off engine, wait for all motion to stop, and inspect for damage. Repair all damage before commencing operation.

22. Before getting off the seat:

A. Stop movement of the vehicle.

B. While braking, set Parking Brake and place range selector in the Neutral position.

C. Shut engine off and wait for all movement to stop.

D. Remove Key from Ignition Switch.

E. Do not park on slopes unless wheels are chocked or blocked.

MAINTENANCE:

23. Before servicing, lubricating or making adjustments to the vehicle, stop engine, set Parking Brake and remove Key from Ignition Switch to prevent someone from accidentally starting the engine.

24. Make sure the vehicle is in safe operating condition, keeping all nuts, bolts, and screws tight.

25. To reduce potential fire hazard, keep the engine area free of excessive grease, grass, leaves, and accumulation of dirt. Do not wash a warm engine or electrical components.

26. Make sure all hydraulic line connectors are tight, and all hydraulic hoses and lines are in good condition before applying pressure to the system.

27. Keep body and hands away from any pin hole leaks in hydraulic lines that may eject high pressure transaxle fluid. Use cardboard or paper to find hydraulic leaks. Transaxle fluid escaping under pressure can penetrate skin and cause injury. Fluid accidentally injected into the skin must be surgically removed within a few hours by a doctor familiar with this form of injury, or gangrene may result.

28. Before disconnecting or performing any work on the hydraulic system, all pressure in the system must be relieved by stopping the engine.

29. If major repairs are ever needed or assistance is required, contact an Authorized TORO Distributor.

30. Disconnect battery before servicing the vehicle. If battery voltage is required for troubleshooting, temporarily connect the battery.

31. If the engine must be running to perform maintenance, or an adjustment, keep hands, feet, clothing, and any parts of the body away from the engine and any moving parts. Keep everyone away.

32. Do not over-speed engine by changing Governor settings. Maximum engine speed is 3350 no-load rpm. To assure safety and accuracy, have an Authorized TORO Distributor check maximum engine speed with a tachometer.

33. Shut engine off before checking or adding oil to the crankcase.

34. To assure optimum performance and continued safety of the vehicle, always use genuine TORO replacement parts and accessories. Replacement parts and accessories made by other manufacturers could be dangerous. Altering this vehicle in any manner may affect the vehicle's operation, performance, durability, or its use may result in injury or death. Such use could also void the product warranty of the TORO Company.

35. This vehicle should not be modified without The TORO Company's authorization. Direct any inquiries to:

Hahn Equipment Co.

A subsidiary of The TORO Company
1625 N. Garvin Street
Evansville, IN 47711-4596

⚠ SAFETY AND INSTRUCTION DECALS

The following safety and instruction decals are installed on the vehicle. If any become damaged or illegible, replace them. Decal part numbers are listed below and in the parts catalog. Order replacements from your Authorized TORO Distributor.



Part No. 36-3400: One Located on Right Front Fender, one on Left Front Fender and one on Battery Box.



Part No. 65-3090: Located on Left Side of Dash Panel.

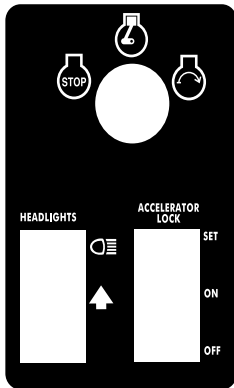

Part No. 100-8470: Located on Upper Left Console.

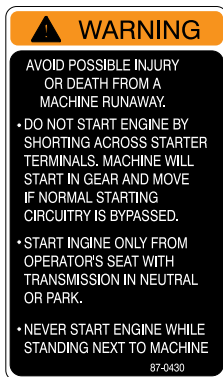

Part No. 87-0430: Located on Rear of Left Fender.



Part No. 104-8750: Located on Lower Front of Front Console.



Part No. 93-0688: Located on Spray Tank Lid.



Part No. 87-0570: Located on Rear Tank Band.

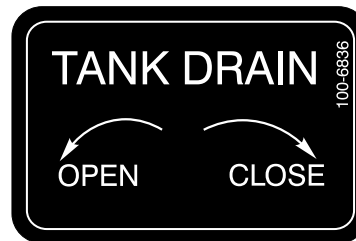

Part No. 100-6836: Located on Tank by Tank Drain Handle.



Part No. 100-8621: Located on Dash Panel.

SAFETY AND INSTRUCTION DECALS

The following safety and instruction decals are installed on the vehicle. If any become damaged or illegible, replace them. Decal part numbers are listed below and in the parts catalog. Order replacements from your Authorized TORO Distributor.



Part No. 62-5550: Located on Front of Front Console.



Part No. 100-8577: Located on Agitation Valve



Part No. 100-6775: Located on Top of Fuel Tank.

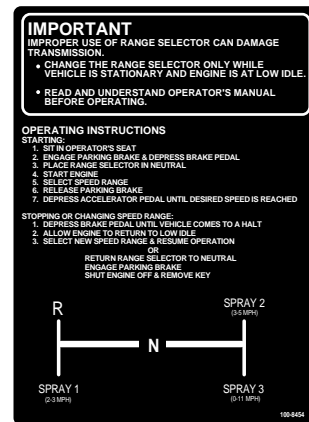

Part No. 100-8454: Located on Lower Left Console.

MULTI PRO® 1200/1250 SERVICE AID

CHECK/SERVICE

1. ENGINE OIL LEVEL (DIPSTICK)
2. ENGINE OIL FILTER
3. TRANSAXLE/HYDRAULIC FLUID LEVEL (DIP STICK)
4. TRANSAXLE HYD. FILTER
5. HYDRAULIC STRAINER
6. GEAR BOX FLUID LEVEL
7. BRAKE FLUID (DOT-3)
8. BELTS (POWER STEERING, CLUTCH)
9. FUEL (UNLEADED ONLY)
10. FUEL FILTER
11. BATTERY
12. AIR CLEANER
13. GREASE (35) POINTS
 — 100 HRS
14. TIRE PRESSURE MAXIMUM
 FRONT: 18 PSI (18" TIRES)
 REAR: 18 PSI (24" TIRES)
15. FUSES (LIGHTS 10 AMP, ACCELERATOR-LOCK 5 AMP, MAIN VEHICLE 30 AMP, SPRAY SYSTEM 10 AMP)
16. PUMP

FLUID SPECIFICATIONS/CHANGE INTERVALS

SEE OPERATORS MANUAL FOR INITIAL CHANGES	FLUID TYPE	CAPACITY		CHANGES/INTERVALS		FILTER PART NO.
		L	QT	FLUID	FILTER	
ENGINE OIL 10°C TO 40°C (50°F TO 104°F)	SAE 10W-30 CD	1.9	2.0	100 HRS	800 HRS	52-050 02-S (9)
TRANSAXLE/HYDRAULIC FLUID	DEXRON II ATF	7.1	7.5	800 HRS	800 HRS	54-0110 (8)
AIR CLEANER	CLEAN EVERY 50 HOURS			200 HRS	400 HRS	47-083 03-S (6)
FUEL/FUEL FILTER	UNLEADED	20	5.3 GAL			24-050 02-S (10)
HYDRAULIC STRAINER				CLEAN 800 HRS		
GEAR BOX	MOBIL SHC 634	.5	16 OZ	400 HRS		

FOR HEAVY DUTY OPERATION, MAINTENANCE SHOULD BE PERFORMED TWICE AS FREQUENTLY.

Part No. 100-8620: Located On Seat Mount Panel.

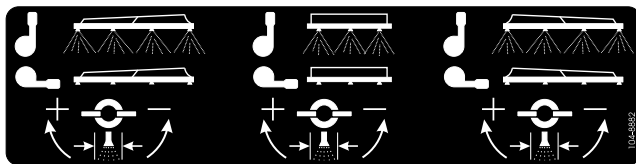

Part No. 104-8882: Located On Spray Valve Console Top

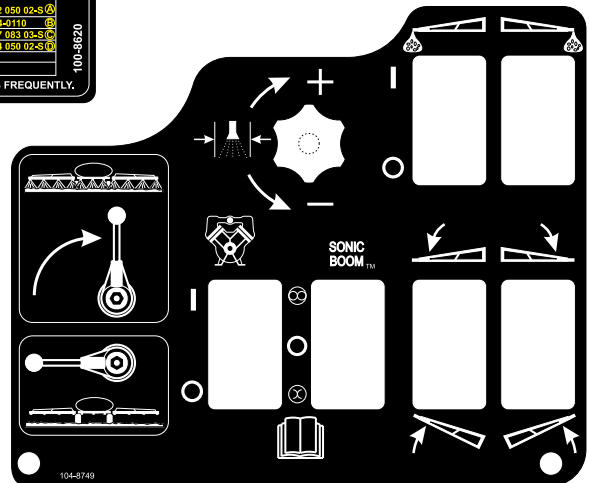

Part No. 104-8749: Located On Spray Valve Console Panel

SPECIFICATIONS

Operator Ear Sound Level Measurement:
83.0 dBA

Vehicle: 4 Wheel, rear wheel drive, front steer, single operator turf sprayer.

Engine: 20HP Kohler V Twin horizontal shaft governed to 3350 rpm, w/30 amp alternator, accel. pump carburetor.

Battery: 12 volt with 360 cold cranking amps @ 0° F.

Fuel Capacity: 5 gallon.

Front Suspension: Full independent rubber torsion swingarm.

Rear Suspension: Rigid.

Steering: Hydraulic power, center pivot linkage.

Tires:

Front: 18 x 9.5-8 slick.
Rear: 24 x 13-12 Multi Trac.

Brakes: 4 wheel hydraulic with dual chamber master cylinder.

ROPS: 2 Post Rollover Protection Structure with Lap Safety Belt (optional).

Lights: Twin halogen headlights.

Transmission:

Integrated transaxle with 3 forward speed ranges and reverse.

Ground Speed:

1st range: 0-3.1 mph
2nd range: 0-5.0 mph
3rd range: 0-11.0 mph

Clutch: Centrifugally engaged variable belt drive (CVT).

Sprayer Tank: 160 gallon tank, Inductive Agitation, polyethylene material, large sump, top controlled drain valve.

Spray Pump: Diaphragm pump, proportional ground speed control system. 30 GPM @ 0 psi, dry crankcase, can operate dry, self priming polyurethane diaphragms.

Pressure Relief: Poppet style, 220 psi max

Suction Filter: Top mounted for easy access, 50 mesh stainless steel.

Control Valve: Manual rate adjustment, volumetric control for constant application rate.

Boom Control Valves: Manual ON/OFF, constant application rate with individual sections off.

Agitation Control: Active agitation or return to pump suction.

Spray Applications Rate: Fast and accurate response to ground speed changes.

General Specifications (approx.):

Base Weight: Base unit 1260lbs.

With standard spray sys.
without operator: dry 1610lbs.
full 2900lbs.

Maximum Gross Vehicle Weight: 3,500lbs.

Measurements with spray system:

Overall Width: 56"
Overall Length: 120" with spray system
Height: Top of Tank 43"
Top of Boom "X" Pattern 74"
Ground Clearance: 4.5"
Wheel Base: 62"
Inside Rear Tire Turning Diameter: 96"

SETUP INSTRUCTIONS

ACTIVATE AND CHARGE BATTERY:

⚠ CAUTION

Electrolyte gases are explosive and can cause serious injury to eyes, lungs and skin. Nausea may result if the gases are inhaled.

- **Wear safety goggles and rubber gloves when working with electrolyte or battery.**
- **Charge the Battery in a well ventilated place so gases produced while charging can dissipate.**
- **Unplug charger from electrical outlet before connecting to or disconnecting charger leads from battery posts.**
- **Since the gases are explosive, keep open flames and electrical sparks away from the battery; DO NOT SMOKE!**

Battery will be preactivated prior to shipment. If battery is not activated or filled with electrolyte, it must be removed from vehicle, filled with electrolyte and charged. Bulk electrolyte with 1.260 specific gravity can be purchased from a local battery supply outlet.

1. Loosen knobs securing battery cover to battery base and slide cover off (See FIG. 1).
2. Remove capscrew, washers and locknut securing battery hold down to battery base. Remove hold down and slide battery out of battery base.
3. Remove filler caps from battery and slowly fill each cell until electrolyte is just above the plates.
4. Replace filler caps and connect a 3 to 4 amp battery charger to the battery posts. Charge the battery at a rate of 3 to 4 amperes for 4 to 8 hours.
5. When battery is charged, disconnect charger from electrical outlet and battery posts.
6. Remove filler caps. Slowly add electrolyte to each cell unit up to fill ring. Install filler caps.

IMPORTANT: Do not overfill battery. Electrolyte will overflow onto other parts of the vehicle and severe corrosion and deterioration will result.

7. Slide battery into battery base so battery terminals are toward the front of the vehicle.

8. Install the positive cable (red) to the positive (+) terminal and the negative cable (black) to the negative (-) terminal of the battery and secure with capscrews and nuts. Slide the rubber boot over the positive terminal to prevent possible short-out from occurring.

⚠ WARNING

Connecting cables to the wrong terminal could cause the battery to explode, resulting in personal injury and damage to the electrical system.

- **Make sure Battery Cables do not interfere or rub on any moving or hot parts.**

9. Install battery hold down and secure to base with capscrew, washers and locknut.

10. Reinstall battery cover to battery base and tighten knobs.

Note: For Battery Maintenance, see Electrical Maintenance, page 44.

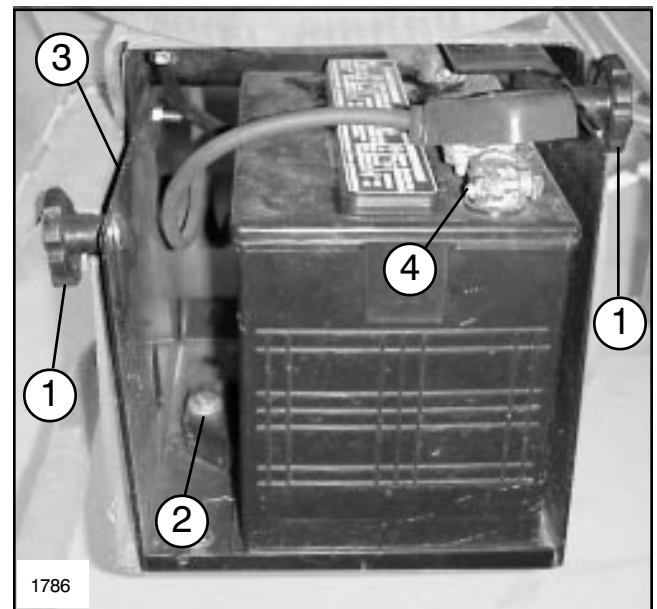

FIG. 1

- | | |
|--------------|-----------------------|
| 1. Knob | 3. Battery Base |
| 2. Hold Down | 4. Positive (+) Cable |

SETUP INSTRUCTIONS

⚠ CAUTION

Chemicals are hazardous and can cause personal injury!

- Securely tighten all sprayer hose clamp connections during initial set-up to prevent leaks and hose blow-offs while spraying system is in operation.

SPRAY SYSTEM:

Note: In the following instructions, "sealer", refers to the Teflon Thread Tape.

NOTE: If optional Hose Reel is to be installed on unit; install Hose Reel before installing Boom. See Set-Up and Parts Manual supplied with Hose Reel.

1. Remove Stop Pins in Boom Mount Assemblies. Apply a heavy coating of grease to the tubes of the two (2) Boom Mount Assemblies and insert them into the Vehicle Frame until Angled Gusset bottoms out against Vehicle Frame. (See FIG. 1)

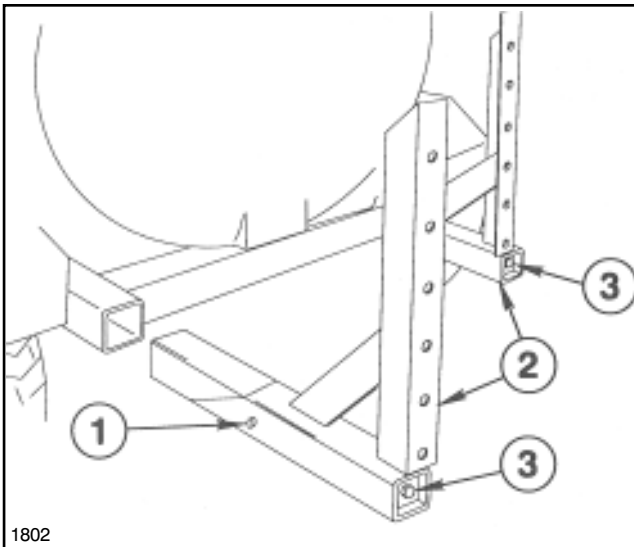

FIG. 1

1. Stop Pin
2. Boom Mount ASM
3. 1/2" x 18" screws

NOTE: If installing the "Enclosed Boom" option in place of the Standard Boom, skip steps 2-20 - See Enclosed Boom Instructions.

2. Install the two (2) Boom Hold-In Assemblies to the top of the Boom Mount uprights as shown in FIG. 2, using four (4) 1/2" x 1-1/4" cap screws, and flange nuts.

3. Attach the two (2) "U"-shaped Boom Mounting Brackets to the third and fourth holes from the top of the Boom Mount uprights with four (4) 1/2" x 1-1/4" cap screws, and flange nuts. Torque to 75 ft-lbs (102 N-m).

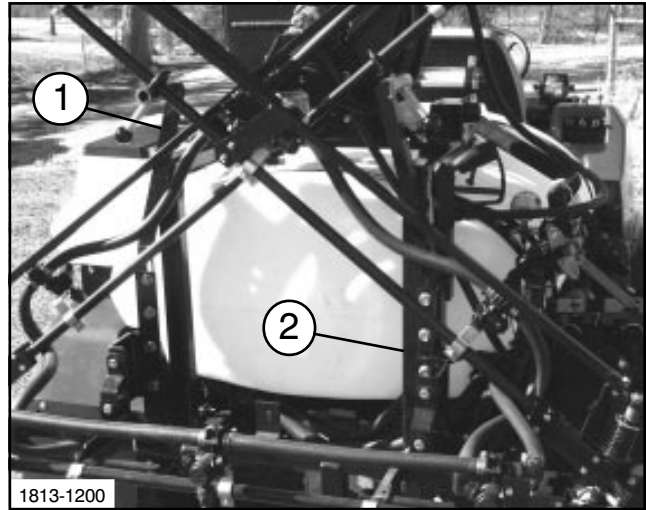

FIG. 2

1. Boom Hold-In ASM 2. Boom Mount Uprights

4. Position a Spacer Tube between the lugs on each side of the Main Frame tube. Insert a 1/2" x 2-3/4" Grade 8 cap screw through the lugs and spacers. Secure the Main Frame to the Boom Mounting Brackets with flange nuts. Torque to 105 ft lbs. (142 N-m) (See FIG. 3)

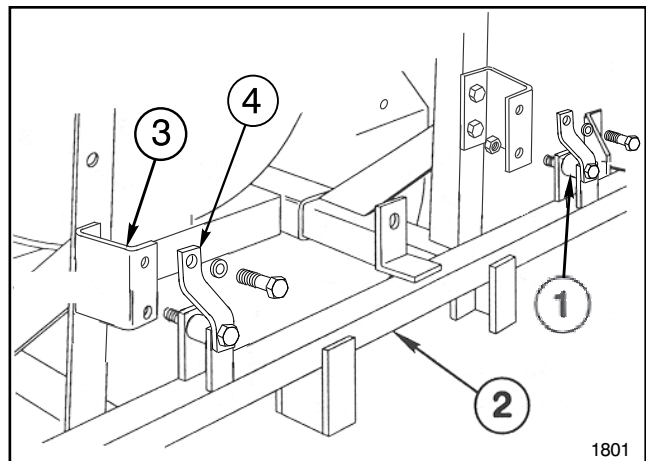

FIG. 3

1. Spacer Tube 3. Boom Mounting Brackets
2. Main Frame Tube 4. Boom Support Strap

5. Using a torque wrench, tighten the 1/2" x 18" screw that joins the Wedges to the Boom Mounts. Tighten to 50 ft. lbs (68 N-m).

6. Position the two (2) Center Boom angles on the Main Frame and secure them to the Main Frame Tube with two (2) square U-bolts, four (4) flat washers and hex nuts. (See FIG. 4, page 13)

SETUP INSTRUCTIONS

7. Center and attach the Center Boom Pipe to the two (2) Center Boom Angle with two (2) clamps, (2) 3/8" x 1" cap screws, flat washers and lock nuts. Once mounted the Center Boom Pipe should be approx. 20" from ground.

8. Loosely attach the Double Barb Turret Body with the Turret Body Clamp in the approximate center of the Center Boom Pipe. For the most uniform spray coverage position all Nozzles level as shown in FIG. 4.

9. Loosely attach a Single Barb Turret Body with the Turret Body Clamp to LH end of the Center Boom Pipe. Loosely attach a threaded Turret Body with the Turret Body Clamp to RH end of the Center Boom Pipe.

10. Place two (2) Hose Clamps on two (2) 3/4" x 19" Jumper Hoses and connect the two (2) "end" Turret Bodies to the Double Barb Turret Body. Space nozzles 20" apart and tighten fasteners securely. Apply thread sealer and install 90° 3/4" Hose Barb on the Threaded Turret Body. (See FIG. 4, page 13)

11. Attach the two (2) Strut Assemblies to the two (2) adjustable clevises found on each side of the Main Frame tube with (2) 1/2" x 2" clevis pins and two (2) 1/8" x 1" cotter pins. (See FIG. 4, page 13)

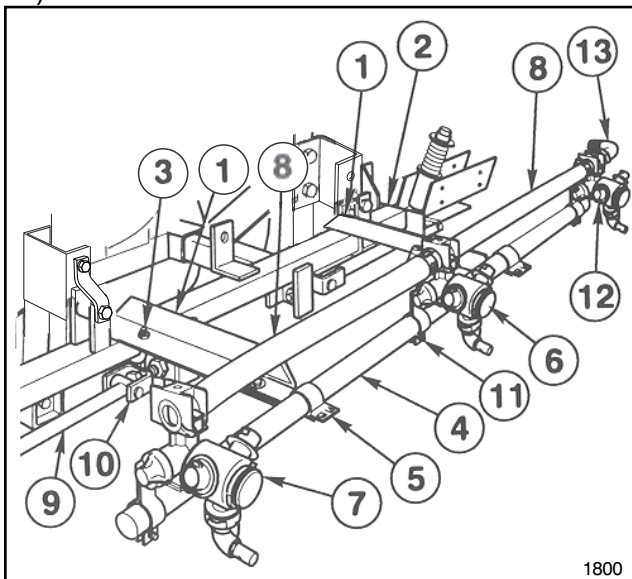

FIG. 4

- | | |
|-----------------------|--------------------------|
| 1. Center Boom Angle | 8. Jumper Hose |
| 2. Main Frame | 9. Strut ASM |
| 3. U-bolt | 10. Adjustable Clevis |
| 4. Center Boom Pipe | 11. Turret Body Clamp |
| 5. Boom Clamp | 12. Threaded Barb Turret |
| 6. Double Barb Turret | 13. 90° Hose Barb |
| 7. Single Barb Turret | |

NOTE: If the optional "Foam Marker Kit" is to be installed, refer to the instructions furnished with that kit before proceeding to Step 12.

IMPORTANT! DO NOT over-tighten the nuts in Steps 12 and 14. The clamping action could crush the Boom Pipe.

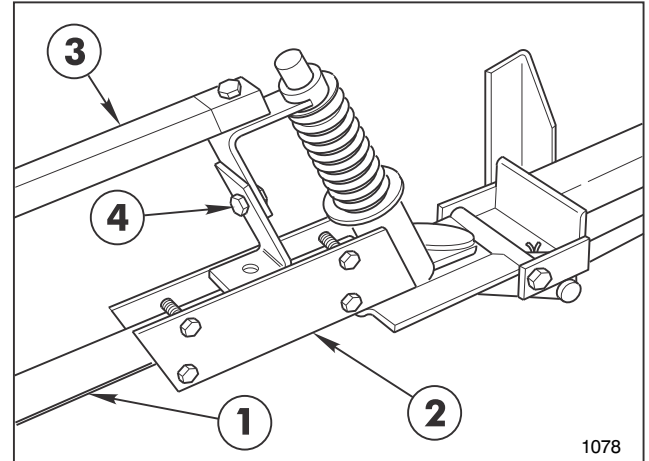

FIG. 5

- | | |
|------------------------|----------------------|
| 1. Extension Boom Pipe | 3. Boom Support ASM |
| 2. Pivot ASM | 4. Height Adjustment |

12. Insert the plugged end of an Extension Boom Pipe into the Pivot Assembly and secure with four (4) 1/4" x 1-1/4" cap screws and lock nuts (See FIG. 5). Repeat on the opposite side to assemble the other Extension Boom.

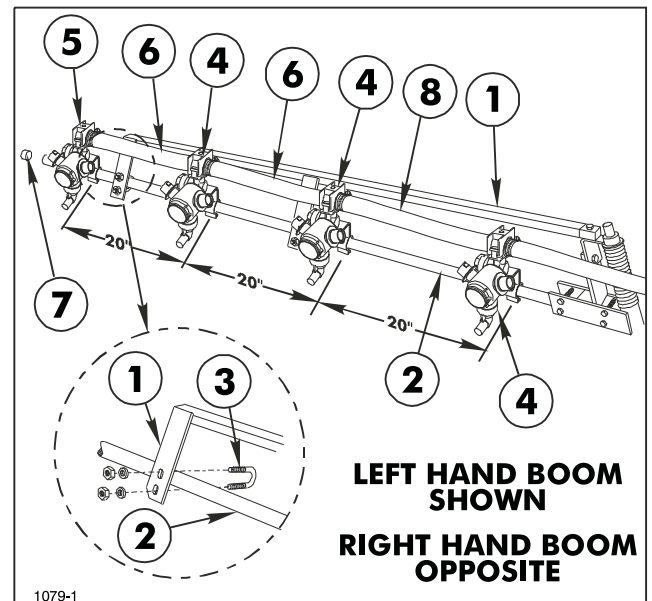

FIG. 6

- | | |
|------------------------|---------------------------|
| 1. Boom Support ASM | 5. Single Barb Turret |
| 2. Extension Boom Pipe | 6. Jumper Hose 3/4" x 19" |
| 3. U-bolt | 7. Boom Cap |
| 4. Double Barb Turret | 8. Jumper Hose 3/4" x 21" |

SETUP INSTRUCTIONS

13. Attach the LH Boom Support Assembly to the Pivot Assembly, using a 5/16" x 1-1/2" cap screw and lock nut. (See FIG. 5 & 6, page 13)

14. Secure the two (2) plates of the Boom Support Assembly to the Extension Boom Pipe, using two (2) 1/4" U-bolts, four (4) lock nuts and flat washers. (See FIG. 6, page 13)

15. Assemble the RH Boom Support Assembly to the other Extension Boom Pipe.

16. Adjust the Booms to a level position by adjusting the jam nuts on the adjustable clevis assemblies (See FIG. 4, page 13) to the desired position, then tighten the nuts against the Main Frame plate.

17. Attach three (3) Double Barb Turret Bodies and one (1) Single Barb Turret Body with Clamp Assemblies on each Extension Boom Pipe as shown in FIG. 6, page 13.

18. Level Nozzles and space 20" apart. Connect the Turret Body Assemblies with 3/4" x 19" Jumper Hoses and a 3/4" x 21" Jumper Hose. Secure with hose clamps. (See FIG. 6, page 13)

19. Place a hose clamp on the center Boom Feeder Hose and attach it to the 90° Hose Barb at the RH end of Center Boom Pipe.

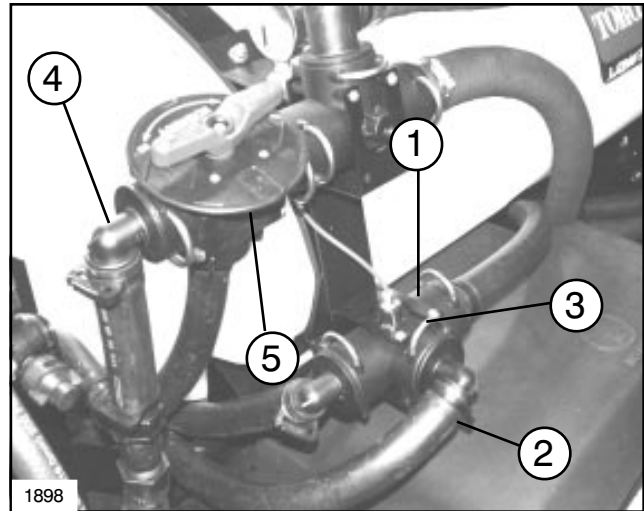

FIG. 7

- | | |
|--------------------------------|---------------------------|
| 1. Pressure Tee | 4. Agitation Hose |
| 2. Pressure Supply Hose | 5. Agitation Valve |
| 3. U-Shaped Fork | |

20. Place a hose clamp on the right and left Boom Feeder Hose and attach them to the Double Barb Nozzles on the right and left Boom Pipes.

NOTES:

BEFORE OPERATING

⚠ CAUTION

Servicing the vehicle while the engine is running or vehicle is not properly secured could result in personal injury or death.

- Before servicing or making adjustments to the vehicle, stop engine, set parking brake, and remove key from the switch.

CHECK ENGINE CRANKCASE OIL:

The engine is shipped with approximately 2 quarts, 1.89 liters, (w/ filter) of oil in the crankcase; however, level of oil **must be checked before and after the engine is first started.**

1. Position vehicle on a level surface. Set Parking Brake. Tilt seat forward to gain access to the engine compartment. (See FIG. 1)

2. Remove dipstick and wipe oil off with a clean cloth. Insert dipstick into tube making sure dipstick is seated fully, remove dipstick and check level of oil. If oil level is low, remove filler cap and add enough oil to raise level up to, but not over, the "F" mark on the dipstick. **Never** operate with the oil level **below** the "L" mark or **over** the "F" mark on the dipstick. Add the oil slowly and check the level often during this process. (See FIG. 2)

3. The engine uses any high-quality detergent oil having the American Petroleum Institute - API - "service classification" SF or SG. See viscosity chart for recommended weight to use.

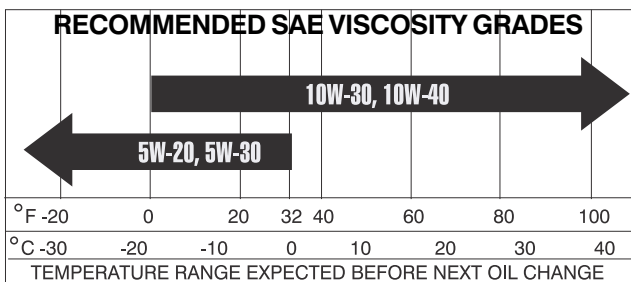

1539

IMPORTANT! Check level of oil BEFORE EACH USE, while engine is cool so the oil has had some time to drain into the sump.

4. Install the dipstick firmly in place and install the oil fill cap.

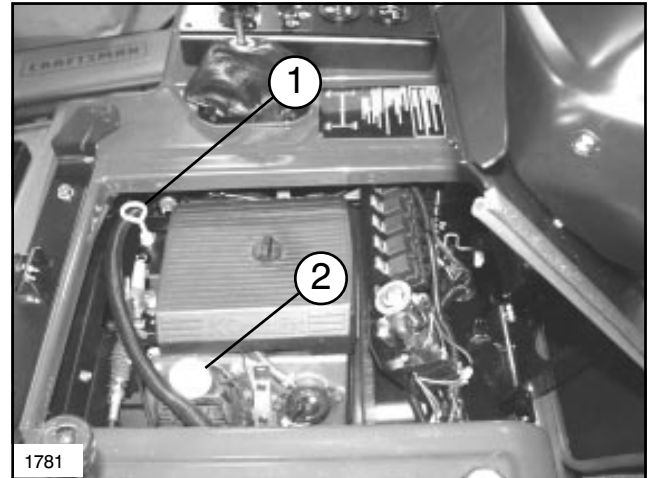

FIG. 1

1. Dipstick 2. Oil Filler Cap

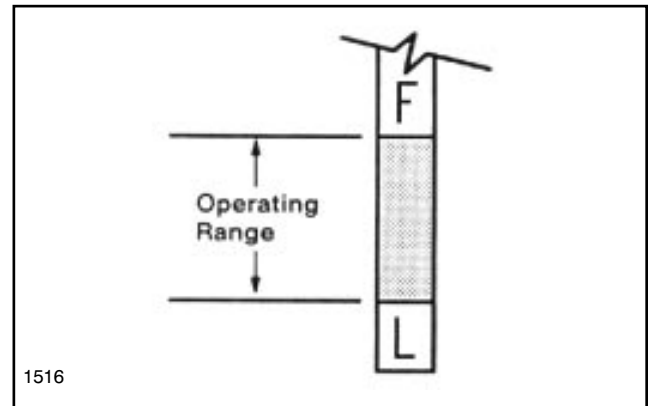

FIG. 2

Change oil and filter after the first 5 hours of operation, thereafter, change oil and filter after every 100 hours of operation. However, change oil more frequently when engine is operated in extremely dusty or dirty conditions.

NOTE: To change the Engine Crankcase Oil and the Oil Filter, see Engine Maintenance, page 34.

BEFORE OPERATING

FILL FUEL TANK:

Fuel tank capacity is 5 gallons (19 liters).

THE TORO COMPANY STRONGLY RECOMMENDS THE USE OF FRESH, CLEAN **UNLEADED** REGULAR GRADE GASOLINE IN TORO GASOLINE POWERED PRODUCTS. UNLEADED GASOLINE BURNS CLEANER, EXTENDS ENGINE LIFE, AND PROMOTES GOOD STARTING BY REDUCING THE BUILDUP OF COMBUSTION CHAMBER DEPOSITS. MINIMUM OCTANE RATING OF 87.

IMPORTANT! California Emissions Regulations REQUIRE the use of UNLEADED GASOLINE ONLY!

1. Clean area around fuel tank cap. (See FIG. 3)

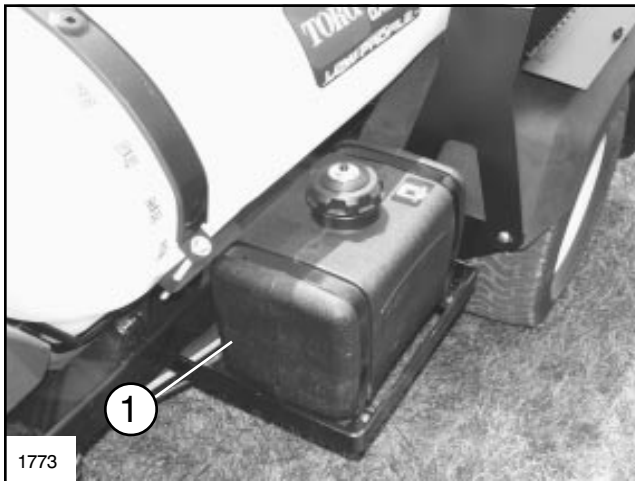

FIG. 3

1. Fuel Tank



FIG. 4

1. Fuel Tank Cap

2. Remove fuel tank cap.

3. Fill tank to about one inch below top of tank (bottom of filler neck). **DO NOT OVERFILL.** Then install cap.

4. Wipe up any fuel that may have spilled to prevent a fire hazard.

FUEL GAUGE: The Fuel Tank Cap shows amount of fuel in Tank. (See FIG. 4)



DANGER

Because gasoline is flammable, caution must be used when storing or handling it.

- Do not fill fuel tank while engine is running, hot, or when vehicle is in an enclosed area. Vapors may build up and be ignited by a spark or flame source many feet away.
- **DO NOT SMOKE** while filling the fuel tank to prevent the possibility of an explosion. Always fill fuel tank outside and wipe up any spilled gasoline before starting the engine. Use a funnel or spout to prevent spilling gasoline, and fill tank no higher than one inch below top of tank, (bottom of filler neck). **DO NOT OVER FILL.**
- Store gasoline in a clean safety approved container and keep the cap on the container. Keep gasoline in a cool, well ventilated place; never in an enclosed area such as a hot storage shed.
- To assure volatility, do not buy more than a 30 day supply of gasoline.
- Gasoline is a fuel for internal combustion engines; therefore, do not use it for any other purpose. Since many children like the smell of gas, keep gas out of their reach; the fumes are explosive and dangerous to inhale.

BEFORE OPERATING



DANGER

To avoid the possibility of a static charge igniting gasoling vapors, the National Highway Traffic Safety Administration recommends the following:

- Purchase and store gasoline only in an approved container.
- Always place gasoline containers on the ground away from your vehicle before filling.
- Do not fill gasoline containers inside a vehicle or on a truck or trailer bed because interior carpets or plastic truck bed liners may insulate the container and slow the loss of any static charge.
- When practical, remove gas-powered equipment from the truck or trailer and refuel the equipment with its wheels on the ground.
- If this is not possible, then refuel such equipment on a truck or trailer from a portable container, rather than from a gasoline dispenser nozzle.
- If a gasoline dispenser nozzle must be used, keep the nozzle in contact with the rim of the fuel tank or container opening at all times until fueling is complete.

CHECK AIR CLEANER/AIR INTAKE:

1. Check the Air Cleaner for any loose or damaged components. (See FIG. 5)

NOTE: Operating the engine with loose or damaged Air Cleaner components could allow unfiltered air into the engine causing premature wear and failure.

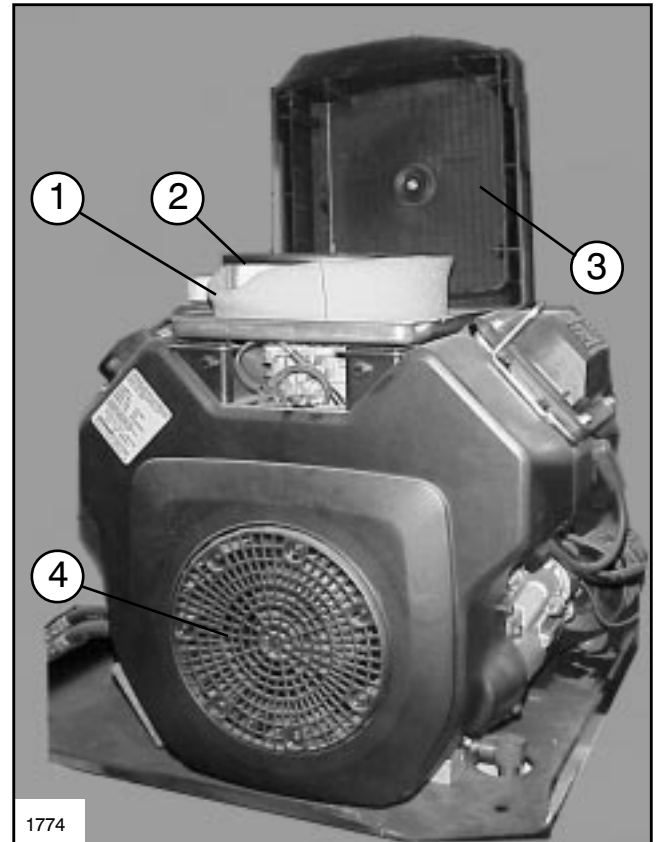

FIG. 5

- | | |
|----------------|---------------|
| 1. Air Cleaner | 3. Cover |
| 2. Air Filter | 4. Air Intake |

2. Check cooling air intake areas and external surfaces of engine. (See FIG. 5) Operating the engine with a blocked screen, dirty or plugged cooling fins, and/or cooling shrouds removed, will cause engine damage due to overheating.

Note: For Air Cleaner & Air Intake Maintenance, see page 33.

BEFORE OPERATING

CHECK TRANSAXLE/HYDRAULIC FLUID:

The transaxle reservoir is filled with Dexron III ATF. Check level before engine is first started and every 8 hours or daily, thereafter. Capacity of system is 7.5 qt. (7.1 liters).

1. Position the vehicle on a level surface. Set Parking Brake.
2. Clean area around dipstick. (See FIG. 6)
3. Unscrew dipstick from top of transaxle and wipe with a clean cloth.
4. Screw dipstick into transaxle making sure it is seated fully, unscrew dipstick and check fluid level. Fluid should be up to top of flat portion of dipstick. If level is low, add enough fluid to achieve the proper level.

IMPORTANT! ALWAYS USE CAUTION WHEN FILLING THE RESERVOIR OR CHECKING THE LEVEL OF THE HYDRAULIC FLUID. KEEP THE SYSTEM FREE OF CONTAMINANTS.

Note: For Transaxle/Hydraulic Maintenance, see page 39-41.

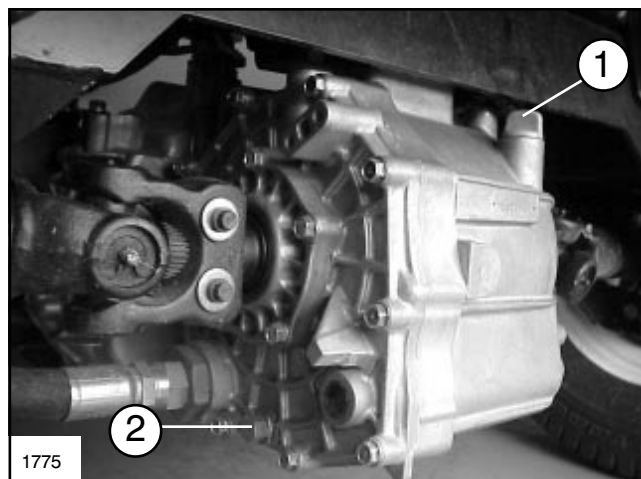

FIG. 6

1. Dipstick
2. Drain plug

CHECK BRAKE FLUID/MASTER CYLINDER:

⚠ DANGER

Operating the vehicle with worn brakes can result in serious injury or death.

The brake fluid reservoir is shipped from the factory filled with "DOT 3" brake fluid. Check level before engine is first started and every 8 hours or daily thereafter.

1. Park machine on a level surface. Set Parking Brake. Tilt seat forward to gain access to the master cylinder and the brake fluid reservoir. (See FIG. 7)

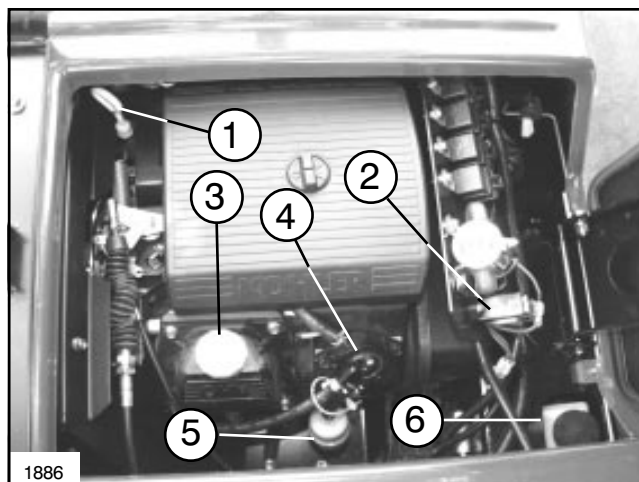

FIG. 7

1. Oil Dipstick
2. Fuse Block
3. Oil Fill
4. Fuel Pump
5. In-Line Filter
6. Brake Reservoir

2. Fluid level should be up to MAX line on reservoir. (See FIG. 8)

3. If fluid level is low, clean area around cap, remove reservoir cap and fill to proper level. **DO NOT OVERFILL.**

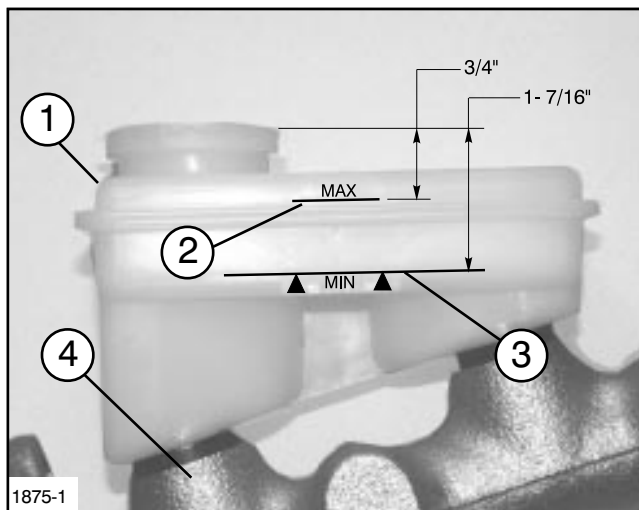

FIG. 8

1. Brake Fluid Reservoir
2. Max. Line
3. Min. Line
4. Master Cylinder

BEFORE OPERATING

Note: Your MULTI PRO® 1200 is supplied with self-adjusting brakes. Replace brakes when worn. See the 104-8754 MULTI PRO® 1200 Parts Manual for replacement. For Emergency/Parking Brake Maintenance, see page 42.

⚠ WARNING
Brake failure can cause loss of control and result in serious injury or death.
• Test Brake function and correct <u>before</u> operation.

CHECK TORQUE OF WHEEL NUTS:

⚠ WARNING
Failure to maintain proper torque could result in failure or loss of wheel and may result in personal injury.
Torque front wheel nuts to 55-65 ft-lb (75-88N-m) and rear wheel nuts or bolts to 45-65 ft-lb (61 TO 88 N-m) after 1-4 hours of operation and again after 10 hours of operation and every 200 hours thereafter.

IMPORTANT! After the "initial run-in" (approximately one to two hours), check all the MULTI PRO® 1200 wheel fasteners for tightness.

CHECK TIRE PRESSURE:

Check tire pressure every 8 hours or daily to assure proper levels. **Maximum** air pressure in both front and rear tires is 18 psi.

The air pressure needed is determined by the payload carried. Once the desired pressure has been ascertained, it is to be used and maintained as a factor in the computer programming to insure the accuracy of the spraying system.

INSPECT TIRES:

Check tire condition for wear or damage. Operating accidents, such as hitting curbs, can damage a tire or rim and also disrupt wheel alignment; so inspect tire condition after any accident.

NEUTRAL SWITCH:

The Multi Pro® 1200 is equipped with a Neutral Switch. The purpose of this switch is to ensure that the vehicle will not start and the Accelerator Lock will not engage unless the Range Selector is in the NEUTRAL position.

The Neutral Switch is located underneath the Left Control Panel and is accessed by removing the Air Cleaner Cover. (See FIG. 9)

Check and maintain the Neutral Switch in a position that prevents the engine from starting unless the range selector is in the neutral position.

⚠ WARNING
If the engine can be started or the Accelerator Lock can be set without the Range Selector in the Neutral Position, the Neutral Switch circuit is faulty. DO NOT OPERATE THE VEHICLE!

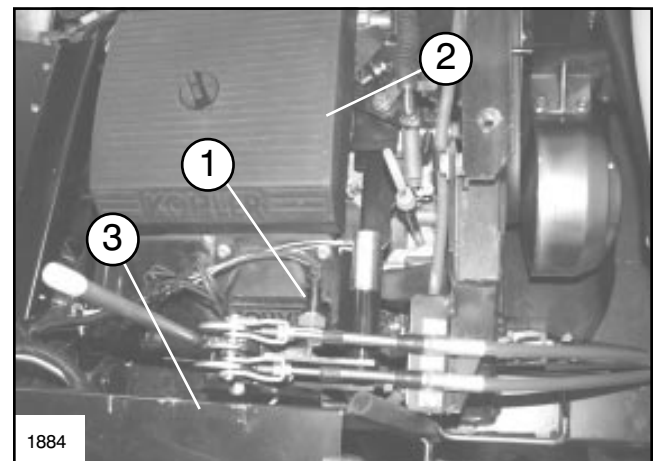

FIG. 9

- | | |
|-------------------|----------------------|
| 1. Neutral Switch | 3. Shield Panel L.H. |
| 2. Air Filter | |

Note: For Neutral Switch Maintenance, see Maintenance, page 29.

VEHICLE CONTROLS

Familiarize yourself with the controls and recommended operating procedures before operating the MULTI PRO® 1200.

1. ACCELERATOR PEDAL:

The accelerator pedal gives the operator the ability to vary engine and ground speed of the vehicle when the transmission is in gear. Depressing the accelerator pedal increases engine RPM, then clutch is engaged, and ground speed is increased. Releasing pedal will decrease engine RPM, clutch is disengaged, and ground speed decreases. (See FIG. 3) For Driving Vehicle, see Operating Instructions, page 22.

2. MANUAL CHOKE:

Pull OUT Choke when starting cold engine. After successfully starting engine, gradually push Choke IN to adjust engine to best running speed. Once engine warms to normal operating temperature, Choke should not be needed. (See FIG. 4, page 21) For Starting Engine, see Operating Instructions, page 22.

3. IGNITION SWITCH:

The ignition switch, used to start and stop the engine, has three positions; OFF, RUN and START. Rotate key clockwise - START position - to engage starter motor. Release key when engine starts. The key will move automatically to the ON position. To shut engine off, rotate key counterclockwise to OFF position. (See FIG. 3) For Electrical Diagram, see Electrical Maintenance, page 45. For Starting Engine, see Operating Instructions, page 22.

4. HOUR METER:

Indicates the total hours of machine operation. The hour meter starts to function whenever the key switch is rotated to "ON" position. (See FIG. 3) For Electrical Diagram see page 45.

5. VOLTMETER:

Indicates the amount of current flow at the Battery. The indicator will register near the center of the dial when the Battery is fully charged. When the engine is running, the indicator should register on the right hand (charge) side of the dial. When the indicator is on the left side, Battery is discharging. (See FIG. 3) For Electrical Diagram, see Electrical Maintenance, page 45.

6. BRAKE PEDAL:

The brake pedal is used to apply service brake to stop or slow vehicle. (See FIG. 3) For Stopping Vehicle, see Operating Instructions, page 23.

 DANGER
Operating the vehicle with worn brakes can result in serious injury or death.

7. EMERGENCY/PARKING BRAKE:

Whenever the engine is shut off, the parking brake must be engaged to prevent accidental movement of the vehicle. To engage the Emergency/Parking Brake, pull back on lever. To disengage, push lever forward. Make sure Emergency/Parking Brake is released before moving vehicle. If vehicle is parked on a steep grade, make sure parking brake is applied. Place chocks at the down hill side of wheels, (see page 25). For Emergency/Parking Brake adjustment, see Emergency/Parking Brake Maintenance, See page 42.

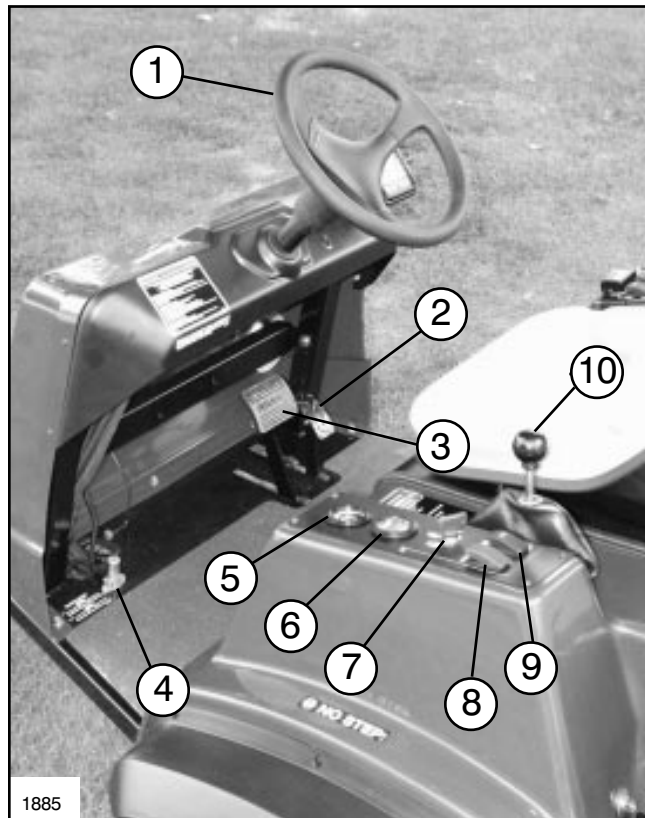

FIG. 3

- | | |
|---------------------------|-----------------------------|
| 1. Steering Wheel | 6. Hour Meter |
| 2. Accelerator Pedal | 7. Ignition Switch |
| 3. Brake Pedal | 8. Headlamp Switch |
| 4. Master On/Off Foot Sw. | 9. Neutral Accelerator Lock |
| 5. Voltmeter | 10. Range Selector |

VEHICLE CONTROLS

8. RANGE SELECTOR:

The Range Selector allows the operator to select a different gear ratio in the transaxle which changes the maximum possible ground speed. Multi Pro® 1200 **is not designed to shift while the vehicle is in motion.** By braking to a complete stop before selecting the new desired range, ground speed stops the transaxle's inertia.

IMPORTANT: Changing the range while vehicle is in motion can damage the transaxle.

Available Ground Speeds:

- 1st range: 0-3.1 mph
- 2nd range: 0-5.0 mph
- 3rd range: 0-11.0 mph

A diagram of the range shift pattern is indicated below. (For location of Range Selector see FIG. 3, page 21)

RANGE SHIFT PATTERN

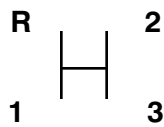

For Adjusting Shift Cables, see Transmission Maintenance, page 41.

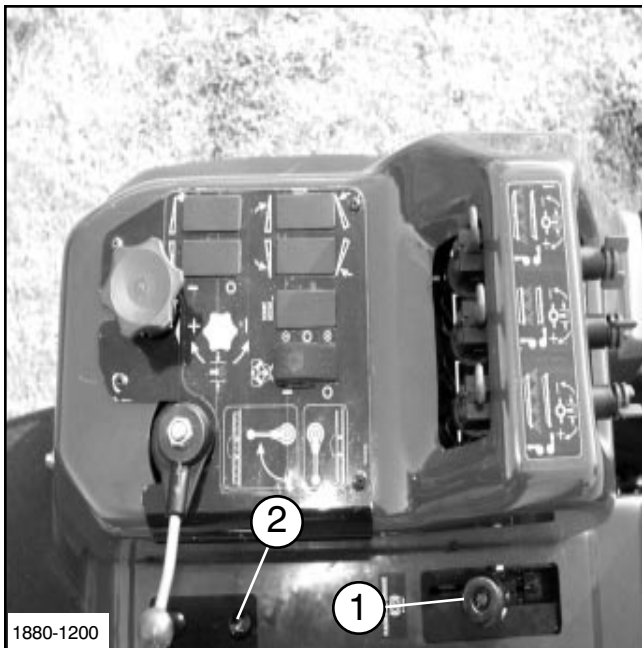

FIG. 4

- 1. Emergency/Parking Brake
- 2. Manual Choke

9. SHIFT LIMITER:

The MULTI PRO® 1200 is equipped with an interlock between the Brake Pedal and the Range Selector. The Brake Pedal must be depressed to allow shifts from neutral or to any other range.

10. NEUTRAL ACCELERATOR LOCK:

The Neutral Accelerator Lock is designed to allow a fixed engine speed when the Range Selector is in the Neutral position. This allows for pump operation, agitation and hand sprayer operation while the Multi Pro® 1200 is stationary. After starting the vehicle with the Range Selector in the Neutral position, increase engine speed to approximately half throttle. Push the Neutral Accelerator Lock rocker switch forward to the "SET" position and release pressure to engage the Throttle Lock. To change Engine Speed, push the Neutral Accelerator Lock rocker switch backward to the "OFF" position. Increase to desired pressure/engine speed. Push the Neutral Accelerator Lock rocker switch forward to the "SET" position and release to engage the Throttle Lock. (See FIG. 3, page 20) For related maintenance, see Neutral Switch Maintenance, page 29.

11. STEERING WHEEL:

Turns vehicle. If engine stalls or power assist fails due to a malfunction, vehicle steering will require greater effort. (See FIG. 3, page 20)

12. HEADLAMP SWITCH:

Turns Headlamps ON and OFF. (See FIG. 3, page 20) For Electrical Diagram, see Electrical Maintenance, page 45.

OPERATING INSTRUCTIONS

PRE-STARTING CHECKS:

Safe operation begins before taking the vehicle out for a day's work. You should check these items each time:

1. Check tire pressure. See Before Operating, page 18.

NOTE: Turf tires require less pressure than car tires; they require less pressure to minimize turf compaction and damage.

2. Check all fluid levels and add the appropriate amount of TORO specified fluids if any are found to be low. See Maintenance section starting on page 26.

3. Check Brake operation. See Vehicle Controls, page 20, and Emergency/Parking Brake Maintenance, page 42.

4. Check to see that the lights are working. See Vehicle Controls, Headlamp Switch, page 21, and Electrical Maintenance, pages 43-45.

5. Check for oil leaks, loose parts, or any other noticeable malfunctions. Make sure engine is off and all moving parts have stopped before checking for oil leaks, loose parts, and/or other malfunctions.

If any of the above items are not correct, notify your mechanic or check with your supervisor before taking the vehicle out for the day. Your supervisor may want you to check other items on a daily basis, so ask what your responsibilities are.

STARTING ENGINE:

WARNING

Engine exhaust gases contain poisonous carbon monoxide.

- **Carbon monoxide is odorless, colorless and can cause death if inhaled.**
- **Avoid inhaling exhaust fumes and never run the engine in a closed building or confined area.**

1. Sit on Operator's Seat and engage Emergency/Parking Brake. See Vehicle Controls, page 20.

2. Make sure the Range Selector is in NEUTRAL position. See Vehicle Controls, page 21.

3. Make sure the Pump ON/OFF Switch is in the "OFF" position. See Spraying System, Controls and Operation, FIG. 2, page 48.

4. Pull the Manual Choke out to full choke position, if cold starting engine. See Vehicle Controls, page 20.

5. Insert Key into Ignition Switch and rotate it clockwise to start engine. Release Key when engine starts. See Vehicle Controls, page 20.

IMPORTANT! Do not hold Key in starting position longer than 10 seconds at one time. If the engine does not start, wait at least 60 seconds before attempting to start again. Continuous cranking will burn out the Starter motor. If the engine develops sufficient speed to disengage the Starter, but fails to continue running, the engine must come to a complete stop before attempting to restart the engine. If the Starter is engaged while the Flywheel is still rotating, the Starter Pinion and Flywheel ring gear may clash, resulting in damage to the Starter. If the Starter does not turn the engine over, shut off the engine immediately and do not attempt to start the engine until the condition has been corrected. Do not "jump-start" using another, larger battery.

NOTE: Starter motors are pre-lubricated. Brushes normally require servicing only after extended use.

6. Gradually push the choke in to the OFF position after the engine is running.

7. Turn Steering Wheel to the left and right to check steering response.

DRIVING VEHICLE:

1. While depressing Brake Pedal, select speed range. For ground speeds see Vehicle Specifications, page 10.

2. Release Parking Brake.

3. Depress Accelerator Pedal to engage clutch and accelerate to desired ground speed.

NOTE: Leaving ignition switch in the "ON" position for long periods of time without running engine will discharge the Battery.

IMPORTANT! Do not attempt to push or tow the vehicle to start Engine. For Jump Starting Procedures, see page 43.

OPERATING INSTRUCTIONS

STOPPING VEHICLE:

1. To stop the vehicle, remove foot from the accelerator pedal and depress BRAKE pedal. For Brake Pedal, see Vehicle Controls, page 20.

STOPPING ENGINE:

1. To stop engine, rotate ignition key to "OFF" and engage Parking Brake. Remove key from switch to prevent accidental starting. For Ignition Switch, see Vehicle Controls, page 20.

NEW VEHICLE BREAK-IN:

Your MULTI PRO® 1200 is ready for work. To provide the longest vehicle life, follow these guidelines for the first 100 operating hours.

1. Check the fluid and engine oil levels regularly and be alert for indications of overheating in any component of the vehicle.
2. After starting a cold engine, allow engine to warm for approximately 15 seconds before accelerating.
3. Avoid racing the engine.
4. Avoid situations requiring hard stops, especially when hauling heavy loads or carrying attachments. It is necessary to fully break-in a new set of brake linings to achieve full braking performance. Follow these guidelines whenever new linings are installed.
5. Vary vehicle speeds during operation. Avoid excessive idling. Avoid fast starts and quick stops.
6. A "break-in" oil for the engine is not required. Original engine oil is the same type specified for regular oil changes.
7. Refer to the Maintenance section, pages 26-28, of this Manual for any special low hour checks.

OPERATING CHARACTERISTICS:

The vehicle is designed with safety in mind. It has four wheels for added stability. It uses familiar automotive style controls, including the steering wheel and brake pedal. It is important to remember, however, that this vehicle is not a passenger car. It is a Turf Sprayer and not designed for use on roadways. Above all, use good judgement when operating this vehicle.

The vehicle has Ultra-Trac tires, low gear ratios, and other features that give it superior gradeability. These features add to the versatility of the vehicle but, they can also get you into dangerous situations. You must keep in mind that the vehicle is not a recreation vehicle. It is not an all terrain vehicle. And, it is definitely not meant for "stunt driving" or "horsing around". It is a Turf Sprayer, not a play vehicle. Children should not be allowed to operate the vehicle or ride as a passenger on the vehicle. Anyone who operates the vehicle should have a motor vehicle license.

If you are not experienced at driving the vehicle, practice driving in a safe area away from other people. Be sure you are familiar with all the vehicle controls, particularly those used for braking, steering, and shifting. Learn how your vehicle handles on different surfaces. Your operating skills will improve with experience, but as with operating any vehicle, take it easy as you begin. Be sure you know how to stop quickly in an emergency. If you need help ask your supervisor for assistance.

Many factors contribute to accidents. You have control over several of the most important. Your actions such as driving too fast, turning too sharply, and combinations of these are frequent causes of accidents.

One of the major causes of accidents is fatigue. Be sure to take occasional breaks. It is very important that you stay alert at all times.

Never operate the vehicle or any equipment if you are under the influence of alcohol or other drugs. Even prescription drugs and cold medicines can cause drowsiness. Read the label on the medicine or check with your doctor or pharmacist if you are unsure about a certain medication.

One of the most important rules to follow is to go slower in unfamiliar areas. It is surprising how much damage and injury common things can cause. Tree branches, fences, wires, other vehicles, tree stumps, ditches, sand traps, streams, and other things found in most parks and golf courses can be hazardous to the operator.

Avoid driving when it is dark, especially in unfamiliar areas. If you must drive when it's dark, be sure to drive cautiously, using the headlights.

You should remain seated at all times, keeping arms and legs inside the vehicle. The operator should keep both hands on the steering wheel, whenever possible.

OPERATING INSTRUCTIONS

There should never be passengers on or around any part of the vehicle. The vehicle is meant to carry a driver only.

Use of this vehicle for purposes other than what are defined by this manual could expose the operator and/or others to serious injury or death.

SPEED:

Speed is one of the most important variables leading to accidents. Driving too fast for the conditions can cause you to lose control and have an accident. Speed can also make a minor accident worse. Driving head-on into a tree at slow speed can cause injury and damage, but driving into a tree at high speed can destroy the vehicle and kill you.

Never drive too fast for the conditions. If there is any doubt about how fast to drive, slow down.

When using heavy attachments (more than 1000 pounds) such as sprayers, top dressers, or spreaders, etc., operating speeds should be reduced.

TURNING:

Turning is another important variable leading to accidents. Turning too sharply for the conditions can cause the vehicle to lose traction and skid, or even tip over.

Wet, sandy, and slippery surfaces make turning more difficult and risky. The faster you are going, the worse this situation becomes so, slow down before turning.

During a sharp turn at higher speeds, the inside rear wheel may lift off the ground. This is not a flaw in the design, it happens with most four wheel vehicles including passenger cars. If this happens, you are turning too sharply for the speed at which you are traveling. Slow down!

BRAKING:

It is good practice to slow down before approaching an obstacle. This gives you extra time to stop or turn away. Hitting an obstacle can damage the vehicle and its contents. More importantly, it can injure you.

Gross vehicle weight has a major impact on your ability to stop and/or turn. Heavier loads and heavier attachments make a vehicle harder to stop or turn. The heavier the load, the longer it takes to stop.

The braking characteristics also change with attachments on the vehicle. Fast stops may cause the wheels to lock up, which may affect the control of the vehicle. Its a good idea to decrease the vehicle speed with attachments.

Turf and pavement are much more slippery when wet. It can take 2 to 4 times as long to stop on wet surfaces as on dry surfaces.

If you drive through standing water deep enough to get the brakes wet they will not work well until they are dry. After driving through water you should test the brakes to make sure they work properly. If they do not, drive slowly in first gear while putting light pressure on the brake pedal. This will dry the brakes out.

NOTE: Heavy loads and turf conditions affect your vehicle's brake performance and ability to turn quickly without tipping over.

TIPOVERS:

The best way to prevent accidents involving the Multi Pro® 1200 is through continuous supervision and training of operators, and paying constant attention to the area in which the vehicle is being operated.

The best way for operators to prevent serious injury or death to themselves or others is to familiarize themselves with the proper operation of the Muti Pro® 1200, to stay alert and to avoid action or conditions which could result in an accident. In the event of a tip over, the risk of serious injury or even death will be reduced if the operator and all involved follow the instructions provided.

Use of this vehicle for purposes other than what are defined by this manual could expose the operator and/or others to serious injury or death.

The Multi Pro® 1200 is designed to provide safe operation when common sense and good judgement are exercised. An optional system for additional protection is a Rollover Protection Structure (ROPS). A ROPS system will reduce the risk of serious or fatal injury in the unlikely event of a tipover, although the system cannot protect the operator from all possible injuries. When using the ROPS system, a seat belt should **always** be used.

Replace a damaged ROPS. Do not repair or revise. Any alteration of ROPS must be approved by manufacturer.

OPERATING INSTRUCTIONS

DANGER

Tipping or rolling the vehicle on a hill will cause serious personal injury or death.

- **If engine stalls or you lose momentum on a hill, never attempt to turn vehicle around.**
- **Always back straight down a hill in reverse gear.**
- **Never back down in neutral using only the brakes.**
- **Never drive across a steep hill; always drive straight up or down.**
- **Avoid turning on a hill.**

Don't slam on the brakes. Sudden speed change can initiate tipover.

HILLS:

Use extra care when on hills. Never go on hills that are extremely steep. Stopping while going down a hill will take longer than on level ground. Turning while going up or down a hill is more dangerous than turning on the level. Turning while going down hill, especially with the brakes on, and turning up hill while traversing a hill, are particularly dangerous. Even at a slow speed and without a load tipovers are more likely if you turn on a hill.

Do not accelerate while climbing or descending a hill. If you have to turn while on a hill, do it as slowly and cautiously as possible. Never make sharp or fast turns on a hill.

When the vehicle's engine is at low idle and the vehicle has enough momentum to crest over a hill, the vehicle could be prone to coasting/free-wheeling situation. When this situation arises, depress the brakes to slow the vehicle.

If Vehicle stalls or begins to lose headway while climbing a hill, apply the brakes, engage parking brake, place the Range Selector in the Neutral position, restart the engine, and place the Range Selector in the 3rd forward range position. At idle speed, engine and transaxle drag will aid the brakes in controlling the vehicle on the hill and help you back down the hill more safely.

TOWING VEHICLE:

In an emergency, the MULTI PRO® 1200 can be towed a short distance. However, TORO does not recommend this as a standard procedure.

IMPORTANT! Do not tow the vehicle faster than 5 mph (8.05 km/hr) because internal transmission damage may occur. If the vehicle must be moved a considerable distance, transport it on a truck or trailer.

NOTE: When the engine is not running, the power steering will not function, making it difficult (increased effort) to steer.

CAUTION

Towing at excessive speeds could cause vehicle to lose steering control.

- **Never tow vehicle faster than 5 MPH.**

Towing the vehicle is a two person job. Affix a tow line to the frame. **Place the Range Selector in the Neutral position and release the Parking Brake.** If the vehicle must be moved a considerable distance, transport it on a truck or trailer.

MAINTENANCE

⚠ WARNING

Servicing the vehicle while the engine is running or vehicle is not properly secured could result in personal injury or death.

- Before servicing or making adjustments to the vehicle, set parking brake, stop engine, and remove Ignition Key from the switch.

Establish a regular schedule of lubrication to assure trouble free performance.

For a vehicle operated under normal conditions, check and service at the intervals indicated in the chart on the following page. When operating in extremely cold, hot, or dusty conditions, check and service more frequently. For additional engine maintenance information, refer to the Engine Operator's Manual supplied with the vehicle.

SERVICE INTERVAL CHART

MULTI PRO® 1200/1250 SERVICE AID

CHECK/SERVICE

<ol style="list-style-type: none"> 1. ENGINE OIL LEVEL (DIPSTICK) 2. ENGINE OIL FILTER 3. TRANSAXLE/HYDRAULIC FLUID LEVEL (DIP STICK) 4. TRANSAXLE HYD. FILTER 5. HYDRAULIC STRAINER 6. GEAR BOX FLUID LEVEL 7. BRAKE FLUID (DOT-3) 8. BELTS (POWER STEERING, CLUTCH) 9. FUEL (UNLEADED ONLY) 10. FUEL FILTER 	<ol style="list-style-type: none"> 11. BATTERY 12. AIR CLEANER 13. GREASE (35) POINTS → 100 HRS 14. TIRE PRESSURE MAXIMUM FRONT: 18 PSI (18" TIRES) REAR: 18 PSI (24" TIRES) 15. FUSES (LIGHTS 10 AMP, ACCELERATOR-LOCK 5 AMP, MAIN VEHICLE 30 AMP, SPRAY SYSTEM 10 AMP) 16. PUMP
---	---

FLUID SPECIFICATIONS/CHANGE INTERVALS

SEE OPERATORS MANUAL FOR INITIAL CHANGES	FLUID TYPE	CAPACITY		CHANGES/INTERVALS		FILTER PART NO
		L	QT	FLUID	FILTER	
ENGINE OIL 10°C TO 40°C/ 14°F TO 104°F	SAE 10W-30 CD	1.9	2.0	100 HRS	100 HRS	52 050 02-S (A)
TRANS/HYDRAULIC FLUID	DEXRON III ATF	7.1	7.5	800 HRS	800 HRS	54-0110 (B)
AIR CLEANER	CLEAN EVERY 50 HOURS				200 HRS	47 083 03-S (C)
FUEL/FUEL FILTER	UNLEADED	20	5.3 GAL		400 HRS	24 050 02-S (D)
HYDRAULIC STRAINER				CLEAN 800 HRS		
GEAR BOX	MOBIL SHC 634	.5	16 OZ	400 HRS		

FOR HEAVY DUTY OPERATION, MAINTENANCE SHOULD BE PERFORMED TWICE AS FREQUENTLY.

100-8620

DAILY MAINTENANCE SCHEDULE

Daily Maintenance: (duplicate this page for routine use)
Check proper section of Operator's Manual for fluid specifications.

Maintenance Check Item	Daily Maintenance Check For Week Of _____						
	MON	TUES	WED	THURS	FRI	SAT	SUN
✓Neutral Switch							
✓Emergency/Parking Brake							
✓Brake Function							
✓Master Cylinder/Brake Fluid							
✓Engine Oil and Fuel Level							
✓Air Cleaner/Air Intake							
✓Unusual Operating Noises							
✓Unusual Engine Noises							
✓Transaxle/Hydraulic Fluids							
✓Hydraulic Hoses for Damage							
✓Fluid Leaks							
✓Tire Pressure/Tire Wear							
✓Instrument Operation							
✓Diaphragm Pump							
✓Boom Control Valve							
✓Suction Strainer/Filter							
✓Sprayer Hose Clamp Connections							
Lubricate All Grease Fittings*							
Touch-up Damaged Paint							

* Perform immediately after every washing, regardless of the interval listed.

Notation for areas of concern: Inspection performed by _____

Item	Date	Information
1		
2		
3		
4		
5		
6		
7		
8		
9		
10		

Check proper section of Operator's Manual for fluid specifications.

MAINTENANCE SCHEDULE

Minimum Recommended Maintenance Intervals:

Maintenance Procedure	Maintenance Interval & Service													
<div style="border: 1px solid black; padding: 5px;"> <table style="width: 100%; border-collapse: collapse;"> <tr> <td style="width: 50%; padding: 5px;"> Clean and Oil Air Pre-Cleaner Clean Air Intake Check Battery Electrolyte Level Check Battery Cable Connections </td> <td style="width: 12.5%; text-align: center; padding: 5px;">Every 50 hrs.</td> <td style="width: 12.5%; text-align: center; padding: 5px;">Every 100 hrs.</td> <td style="width: 12.5%; text-align: center; padding: 5px;">Every 200 hrs.</td> <td style="width: 12.5%; text-align: center; padding: 5px;">Every 400 hrs.</td> </tr> <tr> <td style="padding: 5px;"></td> <td style="text-align: center; padding: 5px;">"A" Level Service</td> <td></td> <td></td> <td></td> </tr> </table> </div>	Clean and Oil Air Pre-Cleaner Clean Air Intake Check Battery Electrolyte Level Check Battery Cable Connections	Every 50 hrs.	Every 100 hrs.	Every 200 hrs.	Every 400 hrs.		"A" Level Service							
Clean and Oil Air Pre-Cleaner Clean Air Intake Check Battery Electrolyte Level Check Battery Cable Connections	Every 50 hrs.	Every 100 hrs.	Every 200 hrs.	Every 400 hrs.										
	"A" Level Service													
Lubricate All Grease Fittings ⁴ Replace Engine Oil and Filter ² Service Spark Plug Service CVT and Steering Pump Belts			"B" Level Service											
Inspect Tires Torque Wheel Lug Nuts ¹ Boom Control Valve Maintenance Adjust Emergency/Parking Brake Adjust Shift Cables Replace Air Filter				"C" Level Service										
Change Gear Box Gear Lube ⁵ Replace Fuel Filter Replace Spark Plugs Inspect Fuel Lines and Connections Check Front Wheel Toe-In ³				"D" Level Service										
¹ Initial break-in at 10 hours ² Initial break-in at 5 hours ³ Initial break-in at 200 hours ⁴ Immediately after every washing, regardless of the interval listed. ⁵ Initial break-in at 50 hours														
Recommendations: Items listed are recommended every 800 hours or 2 years, which ever occurs first.	Replace Safety Switches Change Transaxle/Hydraulic Fluid and Filter ¹ Clean Transaxle/Hydraulic Strainer Replace Hyd. Oil Filter													

MAINTENANCE

JACKING VEHICLE:

1. Do not start engine while vehicle is on jack because engine vibration or wheel movement could cause vehicle to slip off jack.
2. Do not work under vehicle without jack stands supporting it. The vehicle could slip off the jack injuring anyone beneath it.
3. The jacking points at the front of the vehicle are under the A-arms. (Fig. 1)
4. The rear jacking points are on the rear-most frame support between the angle welds. (Fig. 2)
5. Always chock or block wheels opposite the side which is being jacked.



FIG. 1

1. Front Jacking Points

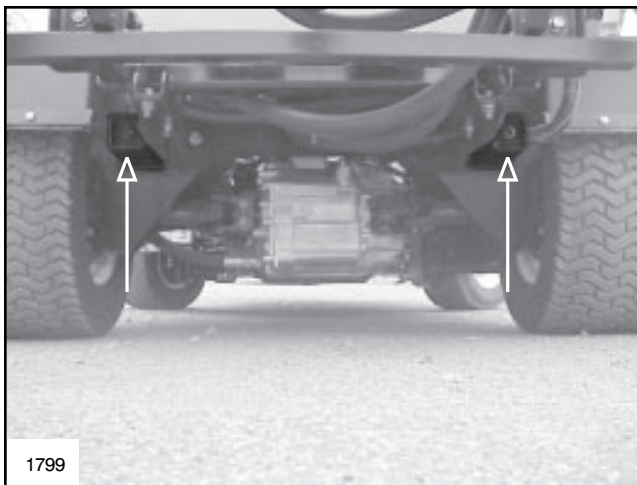

FIG. 2

1. Rear Jacking Points

NEUTRAL SWITCH:

⚠WARNING

If the engine can be started or the Neutral Accelerator Lock can be set without the Range Selector in the Neutral Position, the Neutral Switch circuit is faulty. DO NOT OPERATE THE VEHICLE!

The Multi Pro® 1200 is equipped with a Neutral Switch. The purpose of this switch is to insure that the vehicle will not start and the Accelerator Lock will not engage unless the Range Selector is in the NEUTRAL position.

The Neutral Switch is located underneath the Shifter Boot and is accessed by removing the Air Cleaner Cover.

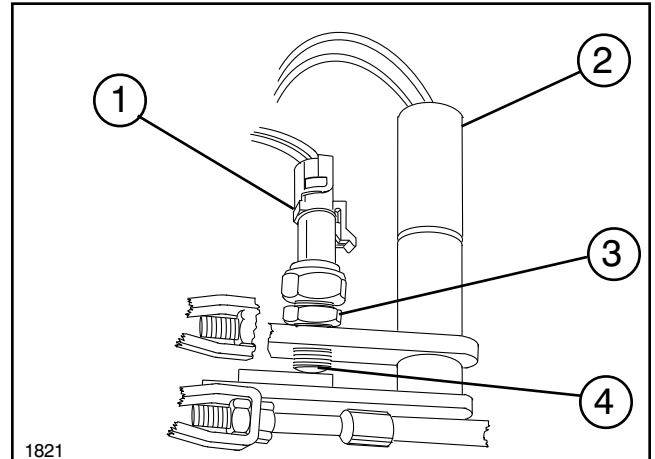

FIG. 3

- | | |
|-------------------|----------------|
| 1. Neutral Switch | 3. Jam Nut |
| 2. Solenoid | 4. Switch Ball |

The Neutral Start mechanism is designed to enable the engine start circuit and Accelerator Lock circuit only when the Range Selector is in Neutral. Proper adjustment of the Neutral Switch must be maintained to ensure this condition.

To adjust the Neutral Switch, follow the steps below:

1. Place the Range Selector in Neutral, stop engine and remove key from the ignition.
2. Remove Air Cleaner Cover.
3. Remove Shifter Ball and jam nut from the Range Selector Handle. Remove six (6) Screws and nuts securing Shift Boot and lift the Boot from Seat Base. This allows a view of the Neutral Switch.

MAINTENANCE

4. Loosen jam nut on Neutral Switch. (See Fig. 3, page 29)
5. Rotate Neutral Switch (toward or away from Actuator) to the position where the Switch Ball is engaged just enough to close the circuit of the Switch. The Neutral Switch circuit should be closed only while the selector is in Neutral. An easy way to verify this condition is to disconnect the Neutral Switch plug and connect an electrical ohm meter to the two terminals inside. Switch the meter to ohms selection and check for continuity while changing gear selections. **The circuit should never have continuity when the range selector is in any driving gear.**
6. When the Neutral Switch is properly positioned, tighten the jam nut.
7. Replace the Shifter Boot, reinstall fasteners and tighten securely. Reinstall jam nut and Shifter Ball.
8. Reinstall Air Cleaner Cover and tighten securely.

NOTE: For inspection of Neutral Switch, see Before Operating, page 18.

PUMP DRIVE GEAR BOX:

1. Change the fluid in the Pump Drive Gear Box after the first 50 hours of operation. Use part number 104-8772 (1 QT.) or Mobil SHC 634 Synthetic Lubricant.

IMPORTANT: Do Not use mineral based gear oil in the Gear Box. Long term damage will occur to the internal components.

2. Drain the fluid and fill to the plug located on the left-hand side of the Gear Box. Capacity is approx. .5 quart.
3. Change the fluid every 400 hours, thereafter or annually, whichever ever comes first.

NOTES:

MAINTENANCE

LUBRICATION:

⚠ WARNING

Servicing the vehicle while the engine is running or vehicle is not properly secured, could result in personal injury or death.

- **Before servicing or making adjustments to the vehicle, set parking brake, stop engine, and remove key from the switch.**

The MULTI PRO® 1200 has 37 grease fittings that must be lubricated regularly with No. 2 General Purpose Lithium Base Grease. If the machine is operated under normal conditions, lubricate all bearings and bushings every 100 hours of operation. More frequent lubrication is required if used for heavy duty vehicle operations.

The grease fitting locations and quantities are: The Front Suspension, which includes Spindle (2) (each side), Tie Rod (2) (each side), Center Steering Pivot (1), Steering Cylinder Tie Rod Ends (2). The Diaphragm Pump(1), Transaxle input Shaft (1), Universal Joints (2), Rear Axle (9) (each side) and Boom Hinges (2) are additional locations.

1. Wipe grease fitting clean so foreign matter cannot be forced into the bearing or bushing.
2. Pump grease into the bearing or bushing.
3. Wipe off excess grease.

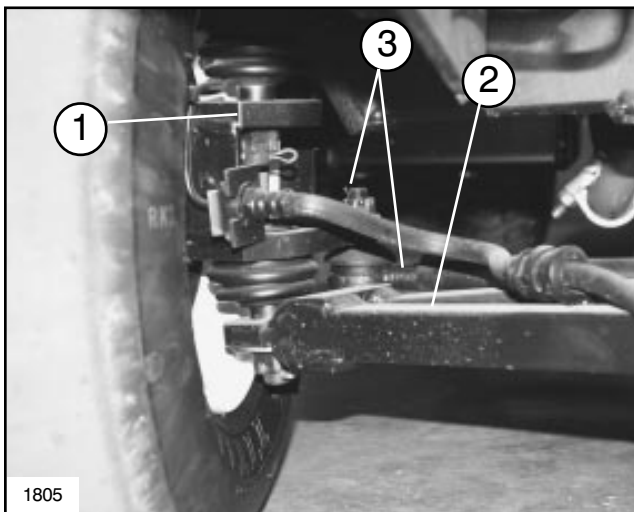

FIG. 4

1. Spindle
2. A-Arm
3. Tie Rod

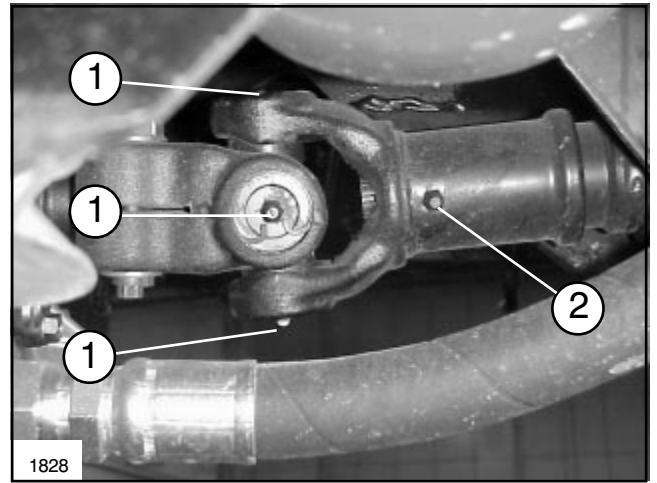

FIG. 5

1. Rear Axle (4 total)
2. Output Drive Shaft Zerk

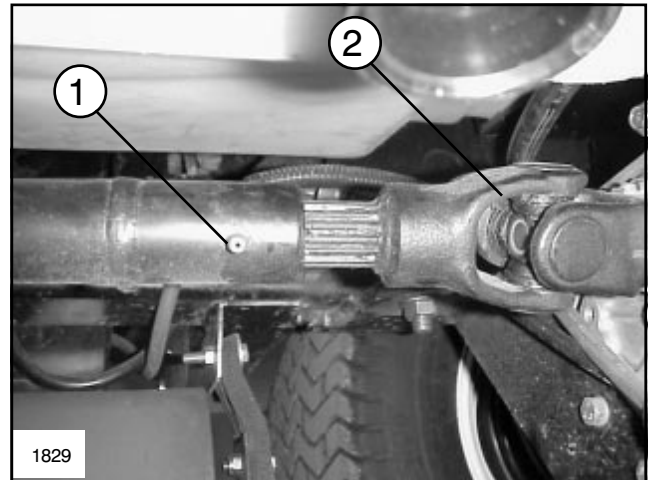

FIG. 6

1. Transaxle Input Shaft
2. Universal Joint

LUBRICATION

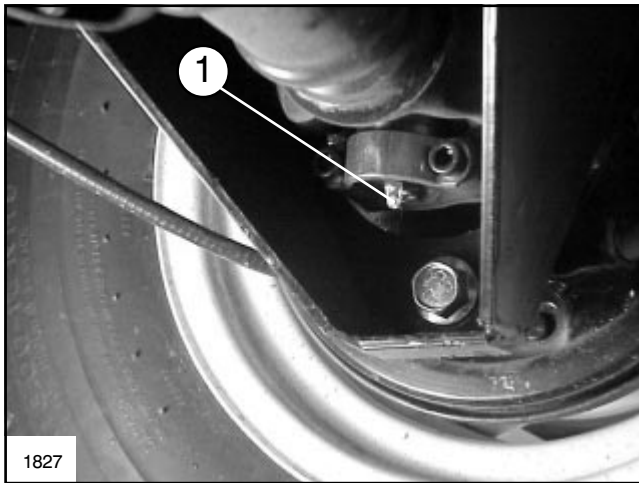

FIG. 7

1. Universal Joint on Rear Axle

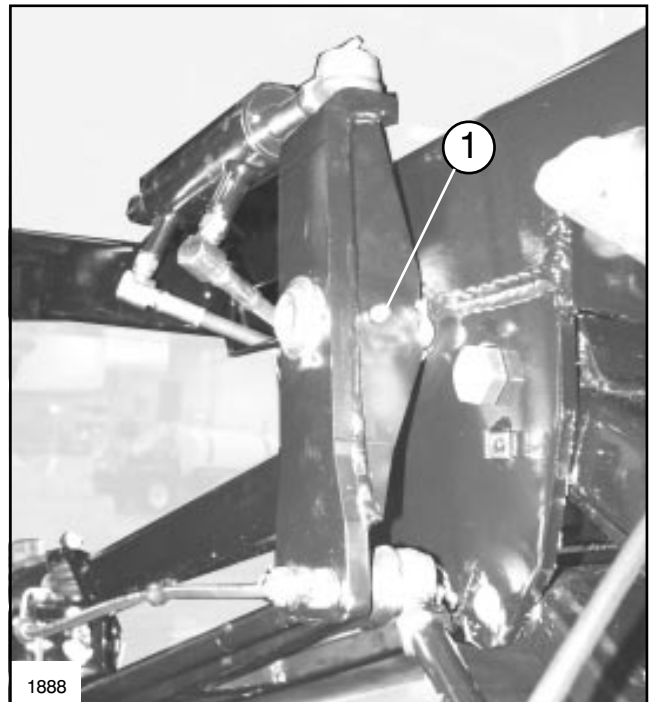

FIG. 10

1. Center Steering Pivot

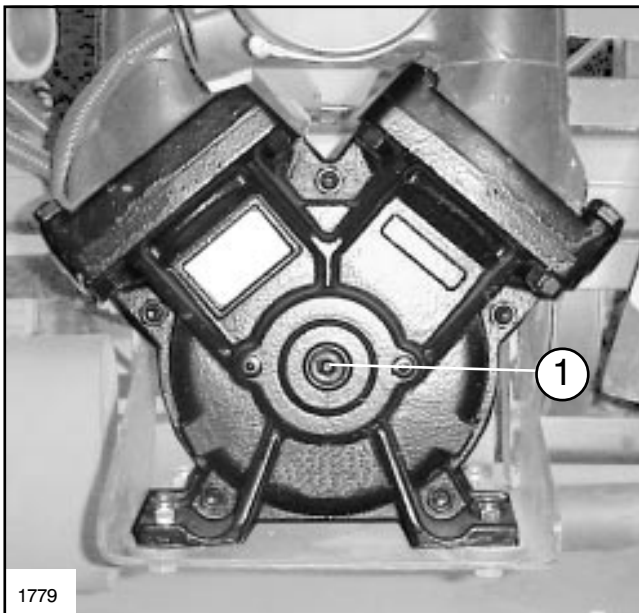

FIG. 8

1. Lubrication Point on Pump

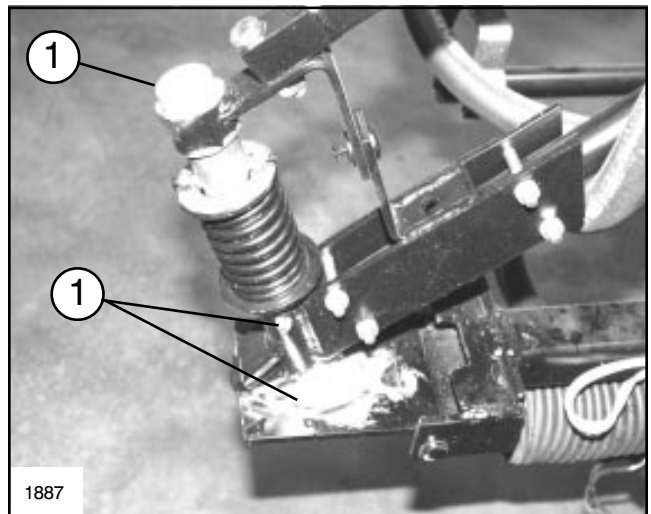

FIG. 11

1. Boom Hinge

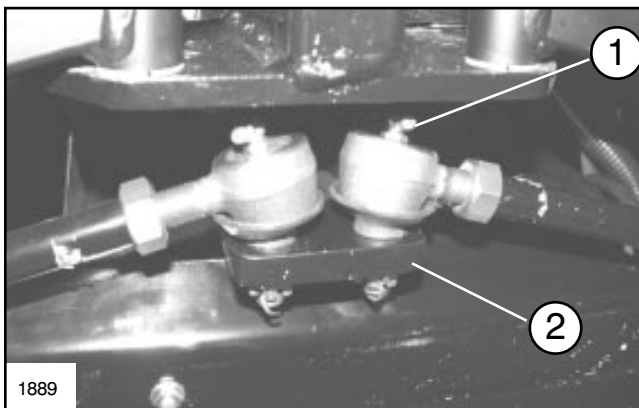

FIG. 9

1. Tie Rod
2. Center Steering Pivot (Ref)

AIR CLEANER MAINTENANCE

AIR CLEANER:

Check the Air Cleaner daily or before starting the engine. Check for and correct buildup of dirt, debris, and loose or damaged components.

IMPORTANT: Operating the engine with loose or damaged air cleaner components could allow unfiltered air into the engine causing premature wear and failure.

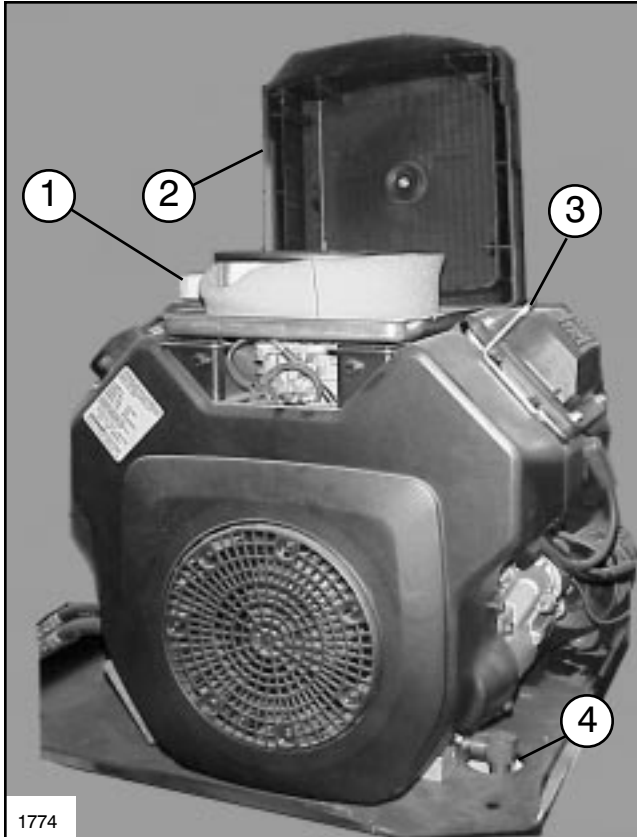

FIG. 12

- | | |
|----------------------|-----------------|
| 1. Oil Fill Cap | 3. Oil Dipstick |
| 2. Air Cleaner Cover | 4. Oil Drain |

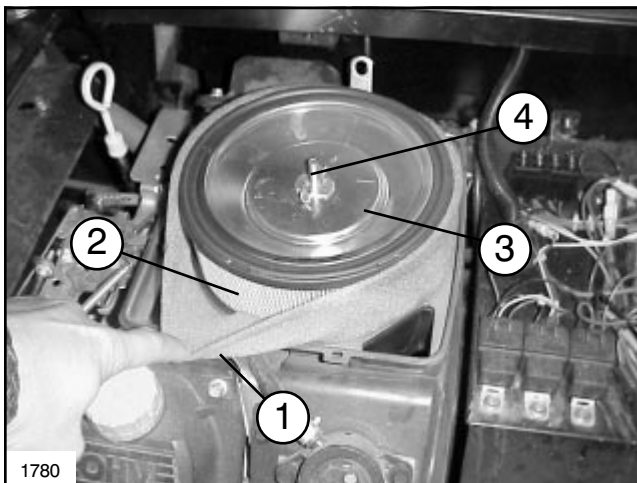

FIG.13

- | | |
|------------------|-----------------------|
| 1. Precleaner | 3. Element Cover |
| 2. Paper Element | 4. Element Cover Seat |

Wash and re-oil the pre-cleaner every 50 hours of operation (more often under extremely dusty or dirty conditions).

1. Remove wing nut and Air Cleaner Cover. (See FIG. 12)

2. Remove the pre-cleaner (FIG. 13) from the paper element and wash in warm water with detergent. Rinse the pre-cleaner thoroughly until all traces of detergent are eliminated. Squeeze out excess water (do not wring). Allow the pre-cleaner to air-dry.

3. Saturate the pre-cleaner with new engine oil. Squeeze out all excess oil (do not wring).

4. Reinstall the pre-cleaner over the paper element.

5. Reinstall the Air Cleaner Cover. Secure Cover with wing nut.

Every 200 hours of operation (more often under extremely dusty or dirty conditions), **check the paper element.** Replace the element as necessary.

1. Remove the Air Cleaner Cover. (See FIG. 12) Remove the element cover nut washer, element cover and paper element with pre-cleaner. (See FIG. 13)

2. Remove the pre-cleaner from the paper element.

3. Do not wash the paper element or use **pressured air**, as this will damage the element. **Replace** a dirty, bent, or damaged element. Handle new elements carefully; **do not** use if the sealing surfaces are bent or damaged.

4. When servicing the air cleaner check the air cleaner base. Make sure it is secured and not bent or damaged. Also check the element cover for damage or improper fit. Replace all damaged air cleaner components.

5. Reinstall the paper element with pre-cleaner, element cover, washer, element cover nut and air cleaner cover. Secure cover with the wing nut.

ENGINE MAINTENANCE

AIR INTAKE/COOLING AREAS:

To ensure proper cooling, make sure the grass screen, cooling fins, and other external surfaces of the engine are kept clean **at all times**.

Every 100 hours of operation (more often under extremely dusty, dirty conditions), remove the blower housing and other cooling shrouds. Clean the cooling fins and external surfaces as necessary. Make sure the cooling shrouds are reinstalled.

IMPORTANT! Operating the engine with a blocked grass screen, dirty or plugged cooling fins, and/or cooling shroud removed, will cause engine damage due to overheating.

NOTE: To check the Air Intake, see Before Operating, page 17.

⚠ WARNING

Servicing the vehicle while the engine is running or vehicle is not properly secured, could result in personal injury or death.

- Before servicing or making adjustments to the vehicle, set parking brake, stop engine, and remove key from the switch.

ENGINE CRANKCASE OIL:

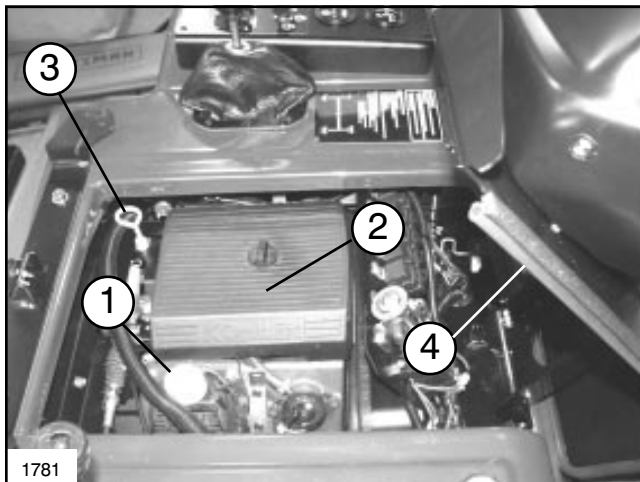

FIG. 14

1. Oil Fill Cap
2. Air Filter
3. Oil Dipstick
4. Raised Operator's Seat

Check the oil level daily or before each use as follows:

1. Have the machine on a level surface with the engine OFF. Tilt seat forward to gain access to the engine compartment. (See FIG. 14)
2. Add oil if necessary to bring the level up to, but not over, the "F" mark on the dipstick (See FIG. 15). For detailed instructions see BEFORE OPERATING, CHECK ENGINE CRANKCASE OIL ON page 15.

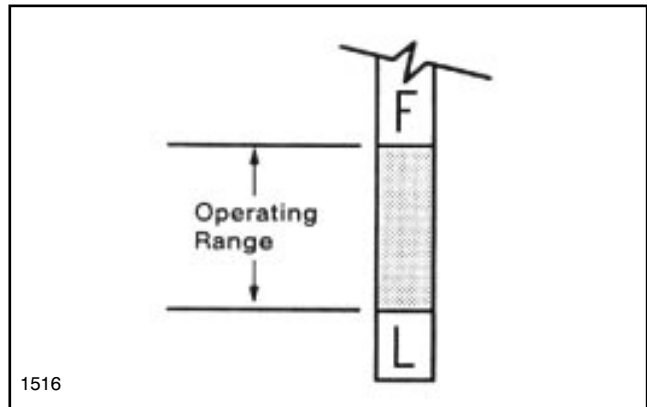

FIG. 15

⚠ WARNING

Continuous contact with used motor oil has caused skin cancer in laboratory mice.

- Do not handle a hot oil filter with bare hands.
- Protect your skin by washing with soap and water.

IMPORTANT! Do not operate the engine with oil level **below** the "L" mark or **over** the "F" mark on the dipstick. Keep the area around the fill tube clean to prevent dirt from falling into the engine.

3. Make sure the oil drain plug is tightened to 10 ft. lbs. (13.6 N.m).
4. Refill the crankcase with new oil of the proper type, through the Fill Cap opening, using a screened funnel. Refer to oil type on page 9. The oil capacity is approximately 2 quarts (1.9 liters), including filter.
5. Check the level with the dipstick while adding oil.
6. Reinstall the oil fill cap and tighten securely. Reinstall the dipstick.

ENGINE MAINTENANCE

OIL & OIL FILTER:

Replace the Oil Filter with each oil change (every 100 hours) as follows:

1. Drain the oil from the engine crankcase. For Oil Drain location see FIG. 17 this page, or FIG. 12, page 33.
2. Allow the Oil Filter to drain.
3. Remove the old Filter (See FIG. 16) and wipe off the Filter Adapter with a clean cloth.
4. Apply a thin coating of new oil to the rubber gasket on the replacement Oil Filter.
5. Reinstall the replacement oil filter to the filter adapter. Turn the oil filter clockwise until the rubber gasket contacts the filter adapter. Then tighten the filter an additional **1/2 turn. DO NOT OVER TIGHTEN!**
6. Reinstall the drain plug. Make sure it is tightened to **10 ft. lb. (13.6 N.m)** torque.
7. Fill the crankcase with new oil of the proper type to the "F" mark on the dipstick. See FIG. 15, page 34.
8. Start the engine and check for oil leaks. Correct any leaks before placing the engine into service. Check oil level to be sure it is up to but not over the "F" mark. For detailed instructions see **BEFORE OPERATING, CHECK ENGINE CRANKCASE OIL**, page 14

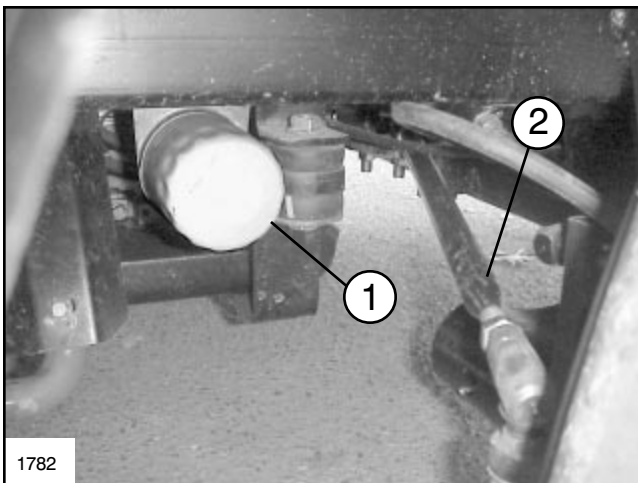

FIG. 16

1. Oil Filter

2. Tie Rod

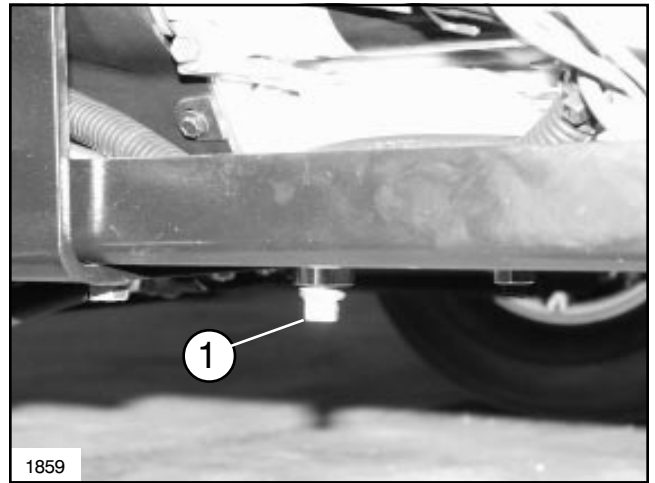

FIG. 17

1. Oil Drain

⚠ WARNING

Servicing the vehicle while the engine is running or vehicle is not properly secured, could result in personal injury or death.

- **Before servicing or making adjustments to the vehicle, set parking brake, stop engine, and remove key from the switch.**

IMPORTANT! Check fuel lines and connections every 400 hours. Inspect for deterioration, damage or loose connections.

IGNITION SYSTEM:

This engine is equipped with an electronic CD (Captive Discharge) ignition system. Other than periodically checking/replacing the spark plugs, no maintenance, timing, or adjustments are necessary or possible with this system.

In the event starting problems should occur, which are not corrected by replacing the spark plugs, see your Kohler Engine Service Dealer for trouble analysis.

ENGINE MAINTENANCE

SPARK PLUG:

Every 100 hours of operation remove the spark plug (See FIG. 18), check condition and reset the gap (See FIG. 19), or replace with a new plug, as necessary. Replace spark plugs after every 400 operating hours to assure proper engine performance. Use a Champion® type RC12YC (or equivalent) spark plug.

IMPORTANT! Equipment to be operated in Canada must use a resistor type spark plug in compliance with Canadian Government regulations.

1. Before removing the spark plug clean the area around the base of the plug to keep dirt and debris out of the engine.

2. Remove the plug and check its condition. Replace the plug if worn, or reuse is questionable.

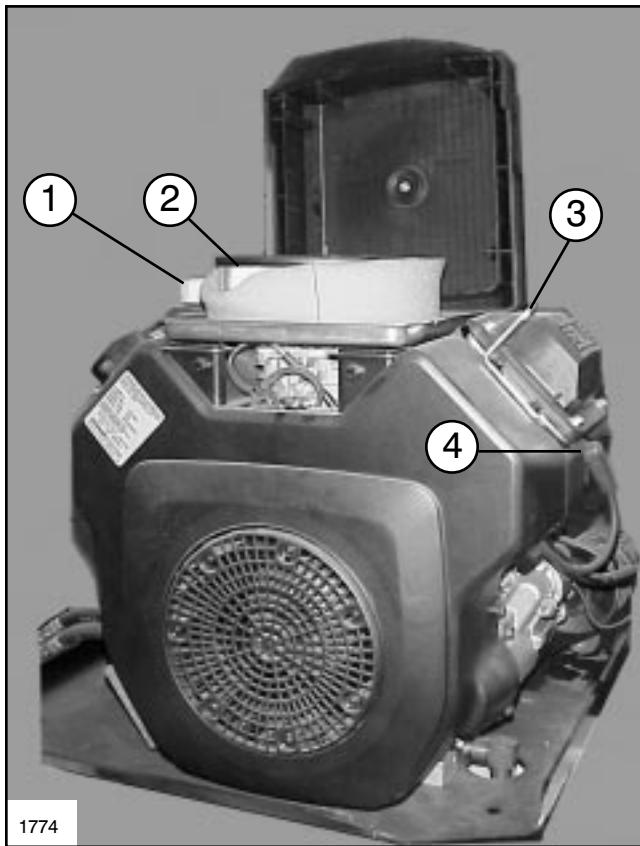

FIG. 18

- | | |
|-----------------|-----------------|
| 1. Oil Fill Cap | 3. Oil Dipstick |
| 2. Air Filter | 4. Spark Plug |

IMPORTANT: A cracked, fouled, dirty or otherwise malfunctioning spark plug must be replaced. Do not sandblast, scrape, or clean electrodes by using a wire brush, because grit may eventually release from the plug and fall into the cylinder. The result is usually a damaged engine.

3. Check the gap using a wire feeler gauge. Adjust the gap to .040 in. (1.02mm) by carefully bending the ground electrode. (See FIG. 19)

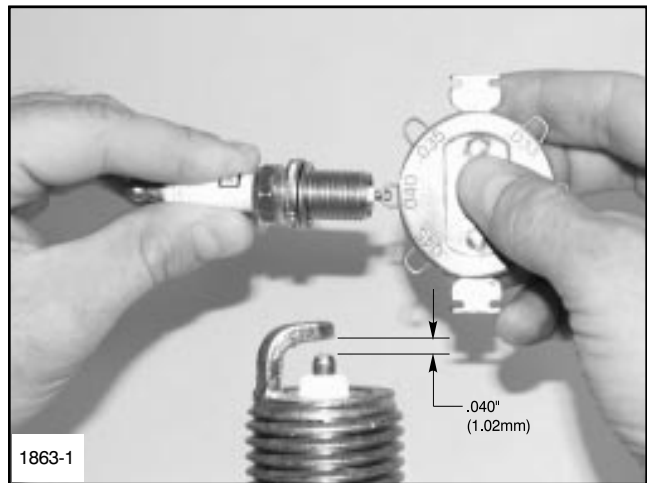

FIG. 19

NOTE: Good operating conditions are indicated if plug has light coating of gray or tan deposit. A dead white, blistered coating could indicate overheating. A black (carbon) coating may indicate an "over-rich" fuel mixture caused by a clogged air cleaner or improper carburetor adjustment.

4. Reinstall the spark plug into the cylinder head. Torque the spark plug to 18-22 ft. lbs. (24.4-29.8 N.m).

NOTE: Do not overtighten plug. The gap may change considerably due to the distortion of the plug outer shell.

ENGINE MAINTENANCE

IN-LINE FUEL FILTER:

The Multi Pro® 1200 is equipped with an in-line type fuel filter located between the fuel tank and the fuel pump. Visually inspect the in-line Fuel Filter periodically and replace when dirty. Replace Filter every 200 hours of use. Replace the filter as follows:

1. Lift Operator's Seat to gain access to the In-Line Fuel Filter (See FIG. 20).
2. Remove the inlet and outlet hose clamps (See FIG. 21).
2. Disconnect the hoses and discard the filter.

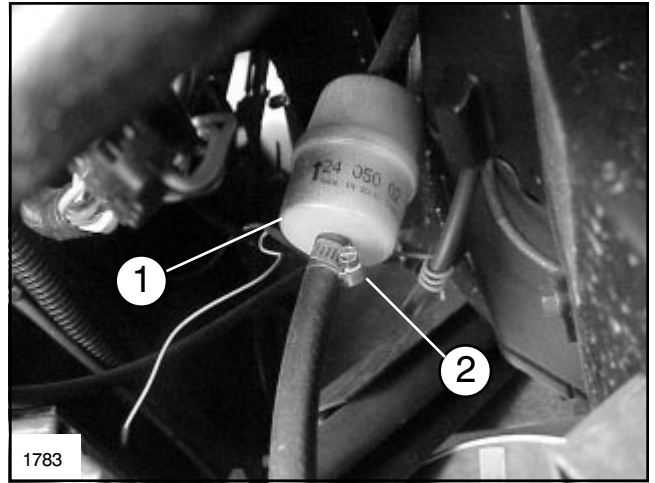

FIG. 21

- 1. In-Line Filter 2. Hose Clamp**

3. Install new filter by connecting the hose from the fuel tank to the inlet side and the hose from the fuel pump to the outlet side.
4. Position the hose clamps and tighten.

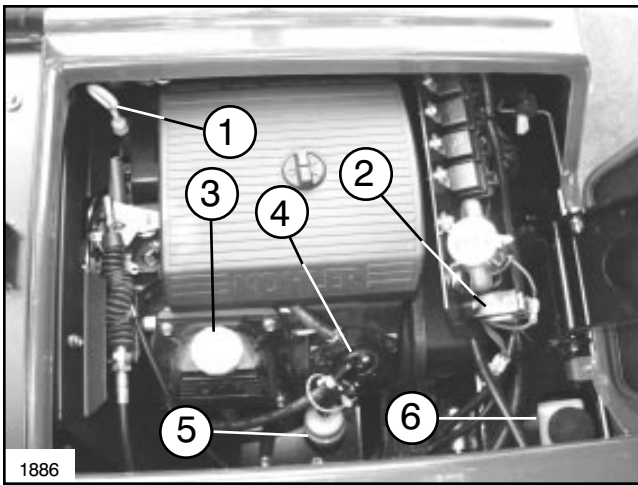

FIG. 20

- | | |
|------------------------|---------------------------|
| 1. Oil Dipstick | 4. Fuel Pump |
| 2. Fuse Block | 5. In-Line Filter |
| 3. Oil Fill | 6. Brake Reservoir |

ENGINE MAINTENANCE

ENGINE TROUBLESHOOTING	Problem	Dirt		Dirty		Incorrect		Engine		Dirty		Faulty	
		No Fuel	Improper Fuel	In Fuel	Air Screen	Oil Level	Over-Loaded	Filter Element	Spark Plug				
When a problem occurs, do not overlook the simple causes. For example, starting problems could be caused by an empty fuel tank. The table lists some common causes of troubles. Do not attempt to service or replace major items or any items that call for special timing or adjustment procedures (governor, valves, etc.). Have this work done by your Kohler Engine Service Dealer.	Will not start	X		X				X	X	X			
	Hard Starting	X	X	X				X	X	X			
	Stops Suddenly	X		X	X	X		X	X	X			
	Lacks Power		X	X	X	X		X	X	X			
	Operates erratically		X	X	X			X	X	X			
	Knocks or pings		X		X			X					
	Skips or misfires		X	X					X	X	X		
	Backfires			X				X	X	X			
	Overheats			X	X	X		X	X				
	High fuel consumption										X	X	

MAINTENANCE

⚠ DANGER

Rotating Pulleys and Belts can cause serious injury.

- Keep hands, feet, and clothing clear while engine is running.
- Stop engine before attempting any belt adjustment.

CLUTCH SYSTEM AND CVT BELT:

1. Proper Operation of Clutch:

- A. Idle - 1000 - 1100 RPM Driven Pulley stationary; Belt not moving.
- B. Accelerate - Clutch Drive Clamps Belt and Driven Pulley Rotates.

2. Critical Factors:

- A. Idle RPM 1000 - 1100.
- B. Belt Guide - Guide should be a distance of 1/8" from Driven Pulley edge. (See FIG. 22)
- C. Belt Condition - Any Belt that has operated for 10 minutes is considered a used Belt.
- D. Wear marks, cracks in Belt.
- E. **CVT BELT SHOULD NEVER NEED ADJUSTING.**

3. Trouble Shooting:

- A. Idle too high - adjust Engine idle.
- B. Belt Guides loose or mislocated - adjust per FIG. 22.
- C. Clutch Components worn - replace components as needed.
- D. Belt - replace as needed.

STEERING PUMP BELT TENSION:

The optimal tension for a V-Belt drive is the lowest tension at which the Belts will not slip under the highest load condition. Too much tension shortens Belt and Bearing life.

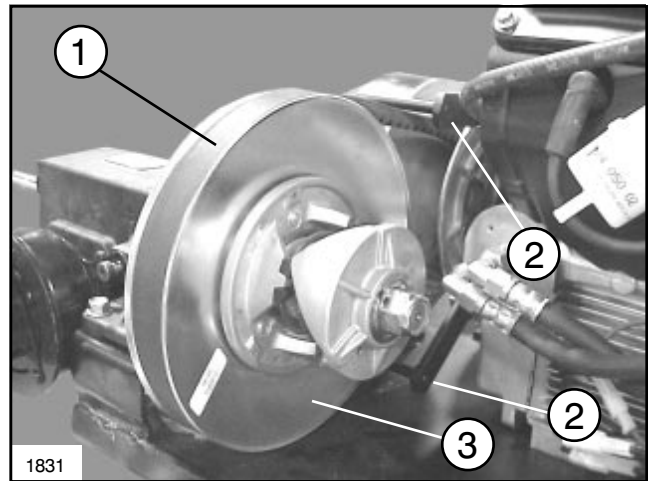

FIG. 22

1. CVT Belt
2. Belt Guide
3. Driven Pulley

1. Check tension by depressing belt at mid span of pump and engine shaft pulleys with 5 lbs. of force. A new belt should deflect .19 - .25 inch. A used belt should deflect .25 - .31 inch. If deflection is incorrect, proceed to next step. If deflection is correct, continue operation.

Check tension and wear of all belts initially after the first day of operation and every 100 hours thereafter.

2. TO ADJUST BELT TENSION:

- A. Loosen Pump Bracket Screws at Engine Mounting Plate.
- B. Slide Pump Bracket to increase tension and tighten screw. Tighten screw closest to engine crankshaft first.

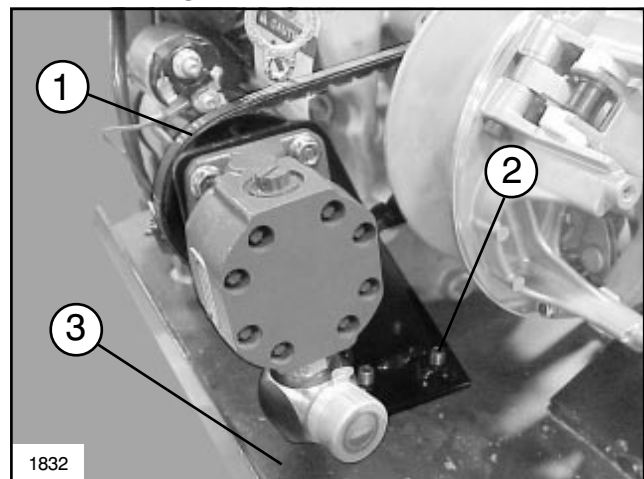

FIG. 23

1. Steering Pump Belt
2. Pump Bracket Screw
3. Engine Mtg Plate

HYDRAULIC SYSTEM MAINTENANCE

CHANGING TRANSAXLE/HYDRAULIC FLUID:

Change Transaxle/Hydraulic Fluid, filter and clean strainer every 800 operating hours, in normal conditions. If fluid becomes contaminated, contact your local TORO distributor because the system must be flushed. Contaminated fluid looks milky or black when compared to clean fluid.

1. Park vehicle on a level surface, set the parking brake, shut engine off, and remove key from ignition switch. Block the two rear wheels.
2. Clean area around transaxle/hydraulic fluid drain plug and remove drain plug from side of reservoir (See FIG. 24), and let transaxle/hydraulic fluid flow into drain pan. Reinstall and tighten plug when hydraulic fluid stops draining.

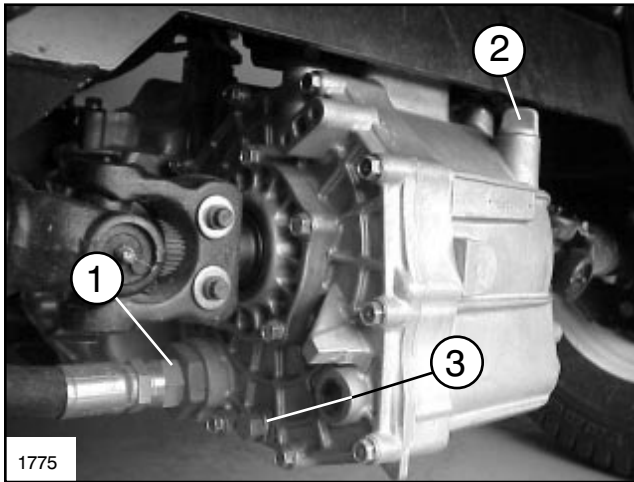

FIG. 24

- | | |
|-------------|---------------|
| 1. Strainer | 3. Drain plug |
| 2. Dipstick | |

3. Fill reservoir through Dipstick opening with approximately 7.5 qt. (7.1 liters) of Dexron III ATF. To check the Transaxle/Hydraulic Fluid, see BEFORE OPERATING, page 18.

4. Start engine and operate to fill hydraulic system. Recheck fluid level and replenish, if required.

IMPORTANT! Use only hydraulic fluids specified. Other fluids could cause system damage.

REPLACING TRANSAXLE/HYDRAULIC FILTER:

Initially, replace the Transaxle/Hydraulic Filter after 10 operating hours, thereafter, replace filter every 800 operating hours.

Use the TORO replacement filter (Part No. 54-0110).

IMPORTANT! Use of any other filter may void the warranty on some components.

IMPORTANT! Keeping the Transaxle/Hydraulic system clean is essential. Servicing the Transaxle/Hydraulic Filter is critical to the life of the hydraulic system.

1. Park vehicle on a level surface, stop vehicle, engage parking brake, turn engine off, and remove key from ignition switch.
2. Clean area around filter mounting area. Place drain pan under filter and remove filter. (See FIG. 25)

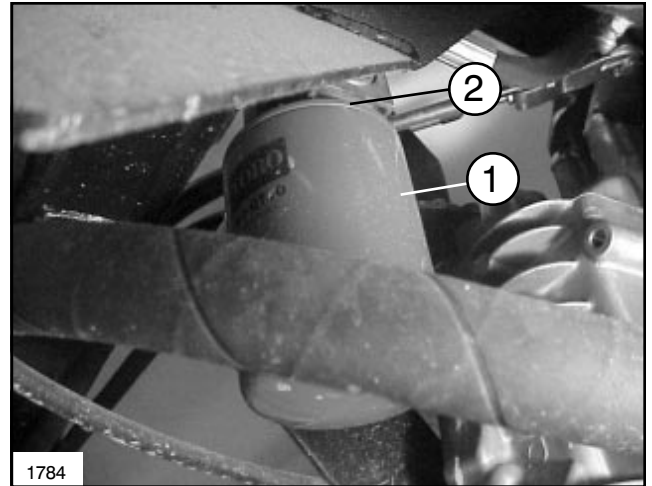

FIG. 25

- | | |
|---------------------|------------------|
| 1. Transaxle Filter | 2. Filter Gasket |
|---------------------|------------------|

3. Lubricate new filter gasket, and **fill the filter with recommended Transaxle/Hydraulic Fluid.**

4. Make sure filter mounting area is clean. Screw filter on until gasket contacts mounting plate. Then tighten filter 1/2 to 2/3 turn.

5. Start engine and let run for about two minutes to purge air from the system. Stop the engine, check the Transaxle/Hydraulic Fluid level, and check for leaks.

HYDRAULIC SYSTEM MAINTENANCE

CHECKING HYDRAULIC LINES AND HOSES:

⚠ CAUTION

Pin hole leaks can eject high pressure hydraulic fluid. Hydraulic fluid escaping under pressure can penetrate skin and cause injury.

Fluid accidentally injected into the skin must be surgically removed within a few hours by a doctor familiar with this form of injury or gangrene may result.

- **Wear gloves and use cardboard or paper to find hydraulic leaks. Never use your hands.**

Inspect hydraulic lines and hoses daily for leaks, kinked lines, loose mounting supports, wear, loose fittings, weather deterioration, and chemical deterioration. Make all necessary repairs before operating.

CLEANING TRANSAXLE/HYDRAULIC STRAINER:

Clean Transaxle/Hydraulic Strainer every 800 operating hours.

1. Park the vehicle on a level surface, stop engine, engage the parking brake and remove key from ignition switch.
2. Remove drain plug from side of reservoir and let Transaxle/Hydraulic Fluid flow into drain pan. (See FIG. 26)
3. Note orientation of hydraulic hose and fitting. Remove transaxle/hydraulic hose and fitting.
4. Remove strainer and clean by back flushing with a clean degreaser. Allow to air dry before reinstalling.

5. Reinstall strainer.

6. Reinstall transaxle/hydraulic hose and fitting to strainer in same orientation.

7. Reinstall and tighten drain plug.

8. Fill reservoir with approximately 7.5 qt. of Dexron III ATF. To check the Transaxle/Hydraulic Fluid see Before Operating, page 18.

PRESSURE SETTINGS:

The pressure relief valve used in the MULTI PRO® 1200 are all factory preset at 1000 psi and cannot be readjusted.

NOTE: To check the Transaxle/Hydraulic Fluid, see Before Operating, page 18.

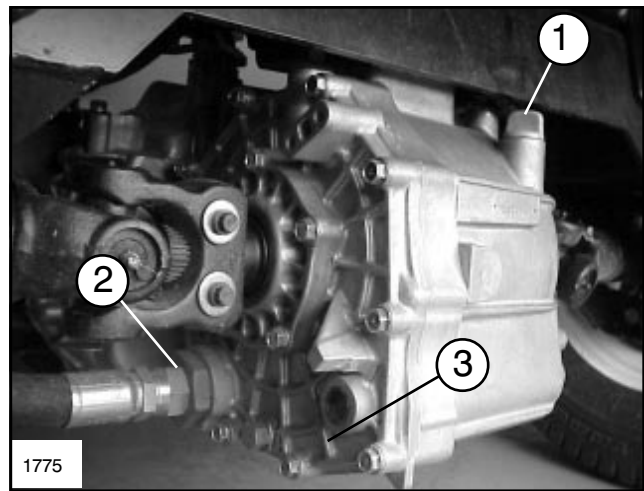

FIG. 26

1. Dipstick
2. Strainer

3. Drain Plug

TRANSAXLE MAINTENANCE

ADJUSTING SHIFT CABLES:

Check adjustment every 200 hours.

1. Place Range Selector in the Neutral position.
2. Remove clevis pins securing shift cables to transaxle shift arms.
3. Loosen clevis jam nuts and adjust each clevis so cable free play is equal forward and backward relative to hole in transaxle shift arm (With transaxle lever free play taken up in same direction).
4. Reinstall clevis pins and tighten jam nuts after adjustments have been attained.

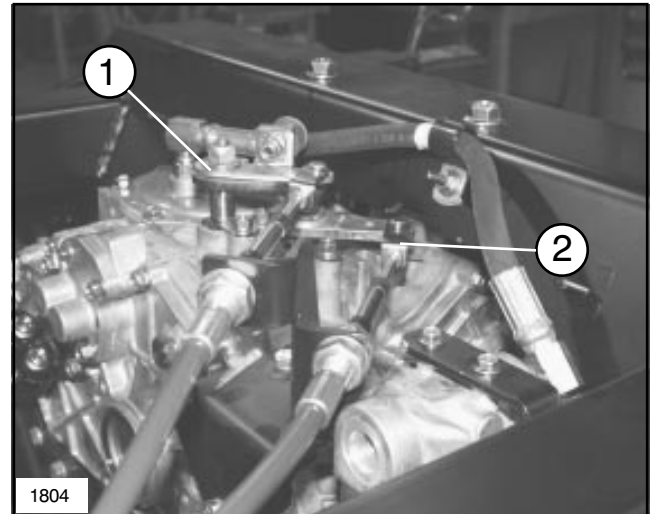
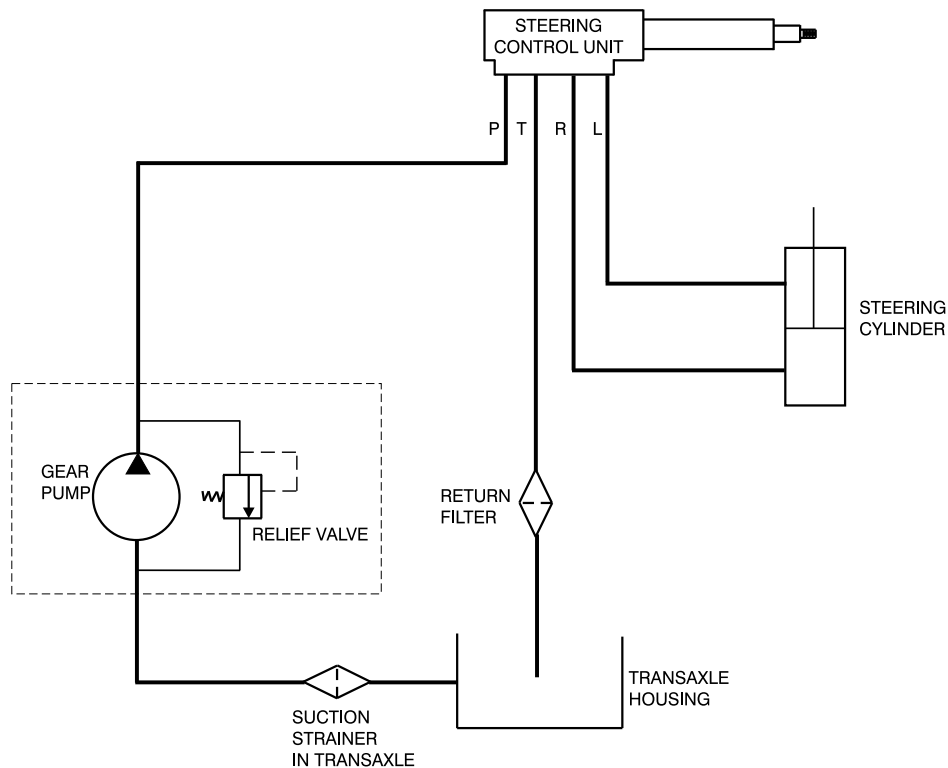

FIG. 27

1. Shift Arm (2nd - 3rd)
2. Shift Arm (1st - Reverse)

HYDRAULIC SYSTEM DIAGRAM



1698

T = TANK
L = WORKING PRESSURE
R = WORKING PRESSURE
P = PRESSURE

MAINTENANCE

INSPECT TIRES:

Check tire condition at least every 200 hours of operation. Operating accidents such as hitting curbs can damage a tire or rim and also disrupt wheel alignment, so inspect tire condition after an accident. To check Tire Pressure, see Before Operating, page 19.

FRONT WHEEL TOE-IN:

After every 400 operating hours or annually, check front wheel toe-in.

1. While the vehicle is unloaded measure center-to-center distance (axle height) at front and rear of steering tires. Front measurement must be equal to the rear measurement plus zero minus 1/8 inch. (FIG. 28)

NOTE: Steering angle should be same in both directions.

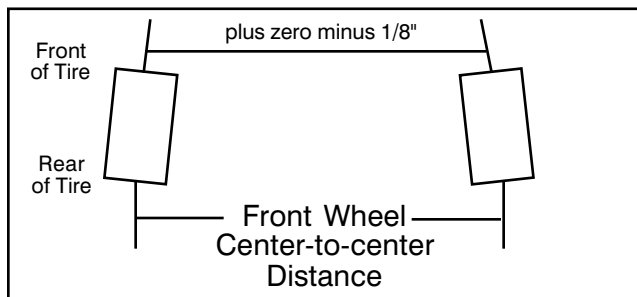

FIG. 28

2. To adjust, loosen jam nuts at both ends of the Tie Rod (FIG. 29).

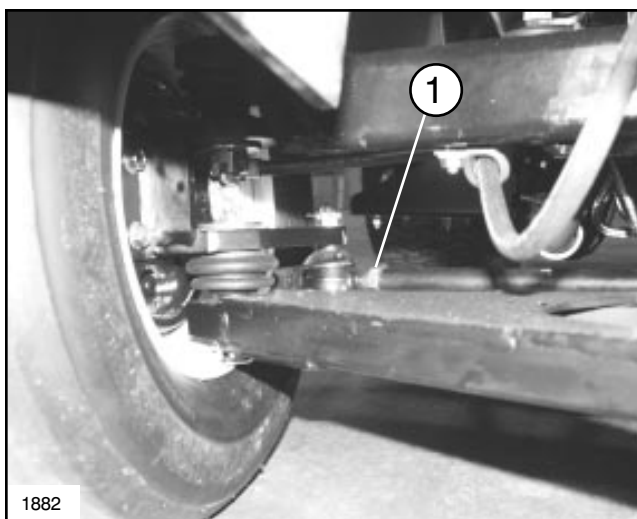

FIG. 29

1. Tie Rod (one nut on each end)

3. Rotate Tie Rod to move front of tire inward or outward.

4. Tighten Tie Rod jam nuts when adjustment is correct.

EMERGENCY/PARKING BRAKE MAINTENANCE:

⚠ WARNING

Brake failure can cause loss of control and result in serious injury or death.

- Test Brake function and correct **before** operation.

Check adjustment of the Emergency/Parking Brake every 200 hours.

1. Loosen set screw securing the Adjustment Knob to Emergency/Parking Brake Lever. Rotate the Adjustment Knob on the end of the Lever. Turn it clockwise to increase brake force, counterclockwise to decrease brake force. (See FIG. 30)

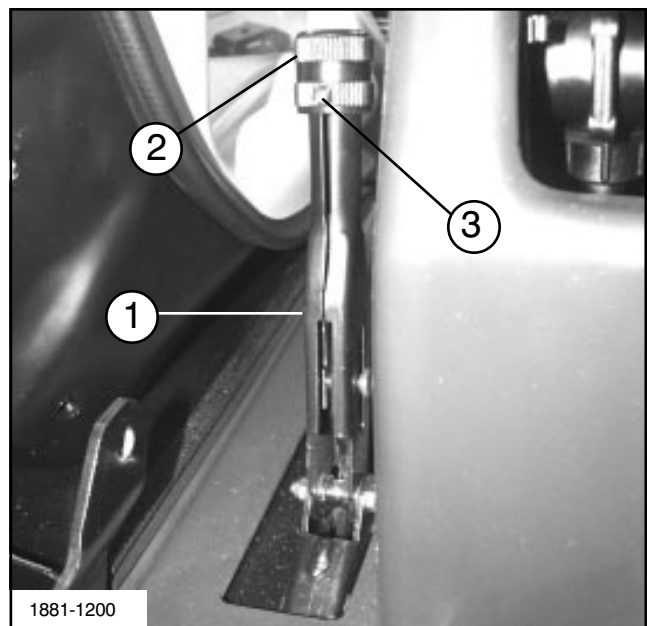

FIG. 30

1. Brake Lever 3. Set Screw
2. Adjustment Knob

2. Rotate knob until a force of 35-45 lbs is required to actuate lever.

3. Tighten set screw after adjustment has been attained.

INSPECT BRAKES:

Visually inspect brakes for worn brake shoes after every 600 hours of operation. The brake fluid reservoir is shipped from the factory filled with "DOT 3" brake fluid. Check level before engine is first started and every 8 hours or daily thereafter. To Check Brake Fluid/Master Cylinder, see Before Operating, page 18.

ELECTRICAL MAINTENANCE

JUMP STARTING PROCEDURE

1. Connect a jumper cable between the positive (+) battery terminals of the two batteries. The positive posts may be identified by a "+" sign on the top of the battery covers.
2. Connect one end of the other jumper cable to the negative (-) terminal of the battery in the other vehicle. The negative terminal has a "-" sign or NEG on the battery cover. DO NOT connect the other end of the jumper cable to the negative (-) post of the discharged MULTI PRO® 1200 battery. Connect it to the engine. DO NOT connect the jumper cable to the fuel system.
3. Start the engine of the vehicle providing the jump start. Let it run for a few minutes, then start the MULTI PRO® 1200 engine.
4. Remove the negative (-) jumper cable first from the MULTI PRO® 1200 engine, then from the battery in the other vehicle.
5. Finally, remove the remaining cable from both batteries.

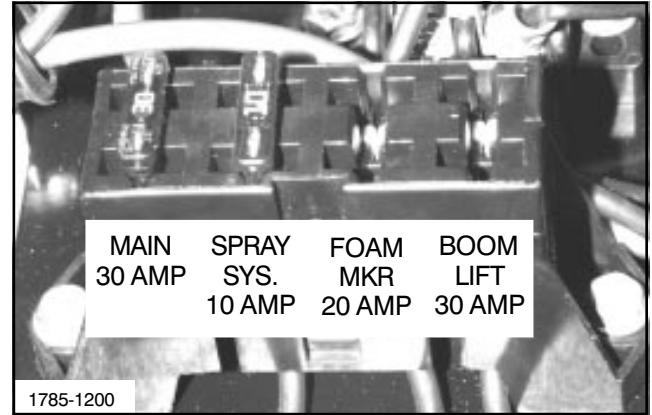

FIG. 31

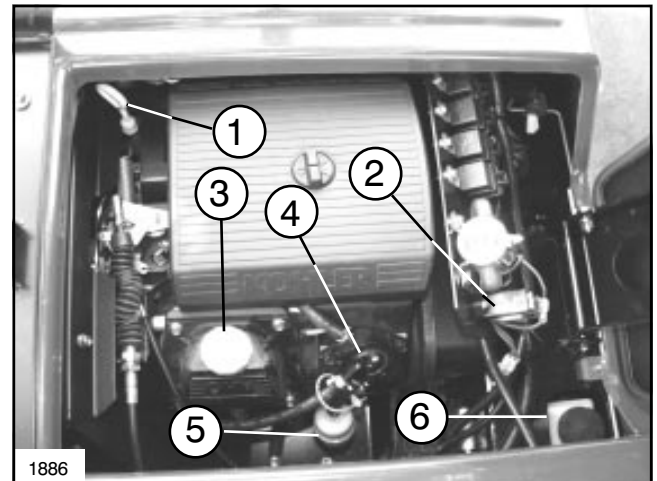

FIG. 32

- | | |
|-----------------|--------------------|
| 1. Oil Dipstick | 4. Fuel Pump |
| 2. Fuse Block | 5. In-Line Filter |
| 3. Oil Fill | 6. Brake Reservoir |

⚠ WARNING

Jump starting can be dangerous. To avoid personal injury or damage to electrical components in vehicle, observe the following warnings:

- Never jump start with a voltage source greater than 15 volts D.C. This will damage the electrical system.
- Never attempt to jump start a discharged battery that is frozen. It could rupture or explode during jump starting.
- Observe all battery warnings while jump starting your vehicle.
- Be sure your vehicle is not touching the jump start vehicle.
- Connecting cables to the wrong post could result in personal injury and/or damage to the electrical system.

FUSES (FIG. 31)

There is one (1) 30 amp and one (1) 10 amp used in the vehicle's electrical system. The fuse box is located under the operators seat. (See FIG. 32)

The 5 amp in-line fuse for the Neutral Accelerator Lock feature, 10 amp in-line fuse for the headlights, and 2 amp in-line fuse for the Shift Limiter are located under the operator seat.

⚠ CAUTION

Electrolyte gases are explosive and can cause serious injury to eyes, lungs and skin. Nausea may result if the gases are inhaled.

- Wear safety goggles and rubber gloves when working with electrolyte or battery.
- Charge the Battery in a well ventilated place so gases produced while charging can dissipate.
- Unplug charger from electrical outlet before connecting to or disconnecting charger leads from battery terminals.
- Since the gases are explosive, keep open flames and electrical spark away from the battery; **DO NOT SMOKE!**

ELECTRICAL MAINTENANCE

BATTERY CARE (FIG. 33):

1. Battery electrolyte level must be properly maintained and the top of the battery kept clean. If the vehicle is stored in a location where temperatures are extremely high, the battery will run down more rapidly than if the vehicle is stored in a location where temperatures are cool.

2. Keep top of battery clean by washing periodically with a brush dipped in ammonia or bicarbonate of soda solution. Flush the top surface with water after cleaning. Do not remove fill cap while cleaning.

3. Battery cables must be tight on terminals to provide good electrical contact.

4. If corrosion occurs at terminals. Remove battery cover, disconnect cables, negative (-) cables first and scrape clamps and terminals separately. Reconnect cables positive (+) cable first and coat terminals with petroleum jelly.

5. Check the electrolyte level every 50 operating hours, or if machine is in storage every 30 days.

6. Maintain cell level with distilled or demineralized water. Do not fill cells above the bottom of the ring inside each cell.

To Activate, Charge and Install the Battery, see Setup instructions, page 11.

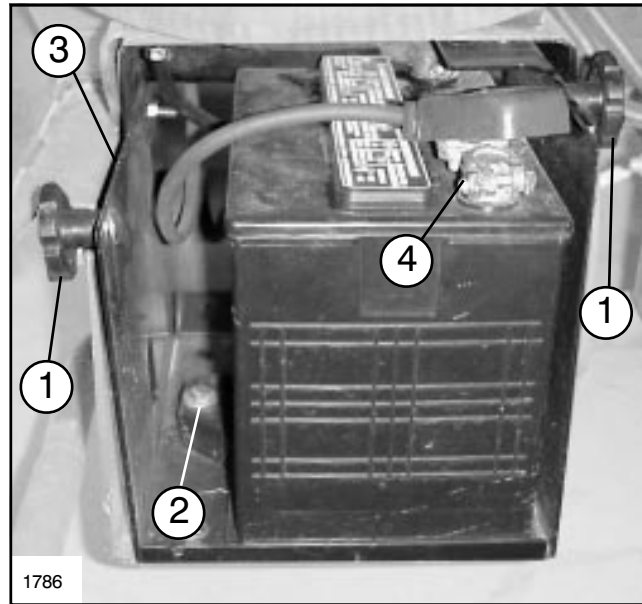

FIG. 33

- | | |
|--------------|-----------------------|
| 1. Knob | 3. Battery Base |
| 2. Hold Down | 4. Positive (+) Cable |

BATTERY STORAGE:

If the vehicle is be stored for more than 30 days, remove the Battery. Store the Battery fully charged on the shelf or on the vehicle; leave the cables disconnected if stored on the vehicle. Store the battery in a cool atmosphere to avoid quick deterioration of the charge. Make sure Battery is fully charged to prevent battery from freezing. The specific gravity of a fully charged battery is 1.250.

WARNING

- **Battery posts, terminals, and related accessories contain lead and lead compounds, chemicals known to the State of California to cause cancer and reproductive harm.**
- **WASH HANDS AFTER HANDLING.**

VEHICLE ELECTRICAL DIAGRAM

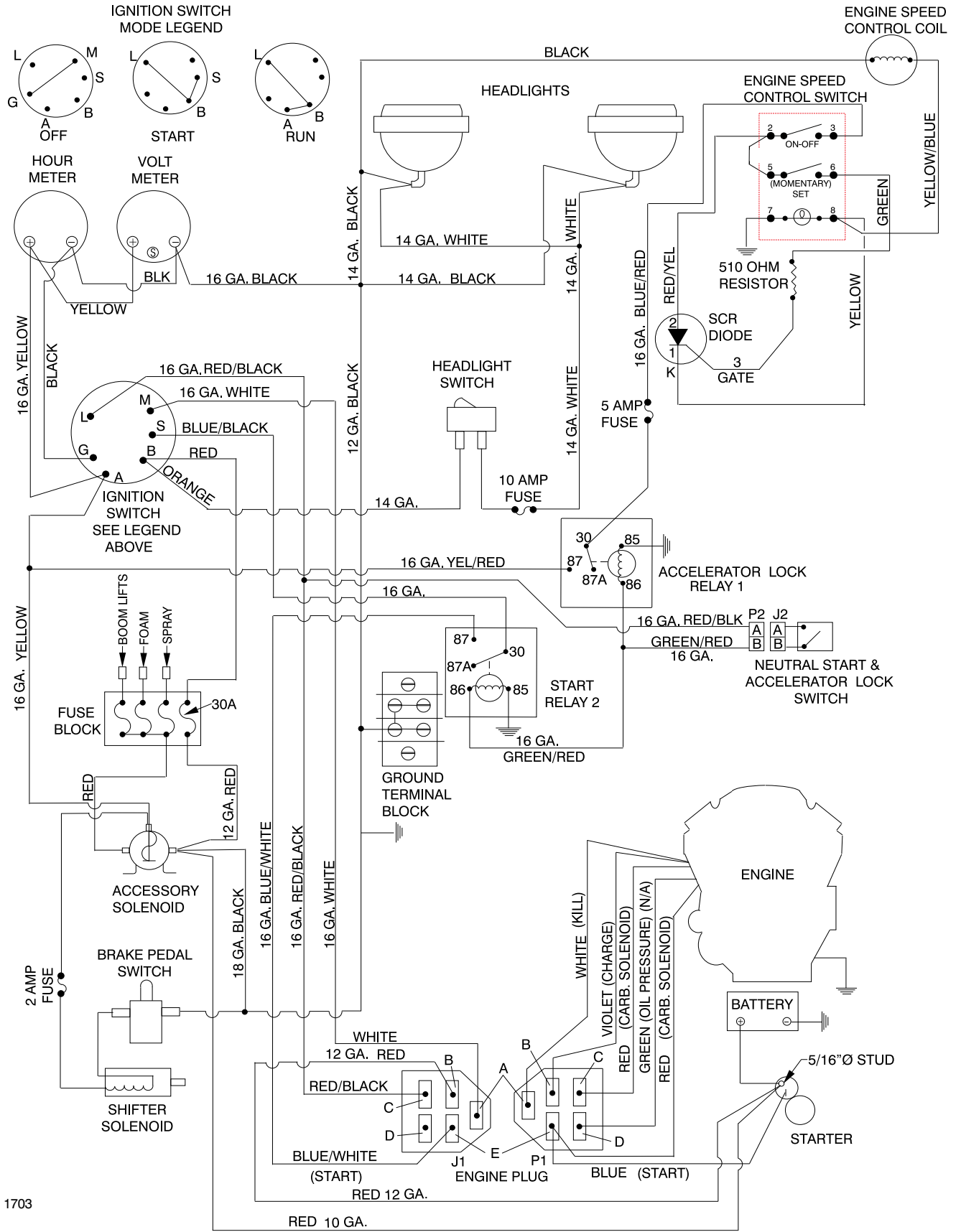

1703

NOTES:

SPRAYING SYSTEM

The MULTI PRO® 1200 Turf Sprayer is primarily a dedicated spray application vehicle with optional Hose Reel, Foam Marker, Sonic Boom, Respirator, PA 17 spreader, Hand Sprayer, and Roll Over Protection Structure (ROPS) feature. Equipped with a positive displacement pump which has speed proportional to ground speed, pump flow is automatically adjusted as ground speed changes. As a result, the application rate remains constant over a wide speed range. The system includes a Master Boom Valve, Individual Boom Valves and a Pressure Control Valve located on the operator's right console, and a Neutral Speed Control on the operator's left console for use with the Hand Sprayer and during filling and mixing. The Spray System itself consists of a Diaphragm Spray Pump, a 160 gallon tank, Spray Pro application monitor and calibration system, and three Boom sections for even application of material. This unit is specially designed to improve the accuracy and uniformity of spray applications.

1. Learn how to operate the Sprayer and how to use the controls properly. DO NOT let anyone operate this equipment without first receiving thorough instructions.

2. Keep all shields, safety devices, and decals in place. If a shield, safety device or decal is malfunctioning, illegible or damaged, repair or replace it before operating the machine.

3. Chemicals can injure persons, animals, plants, soils or other property. To eliminate environmental damage and personal injury:

A. Select the proper chemical for the job.

B. Carefully read the directions printed on the chemical manufacturer's labels before handling chemicals. Instructions on chemical manufacturer's container labels, regarding mixing proportions, should be read and strictly followed.

C. Keep spray material away from skin. If spray material comes in contact with body, wash it off immediately with clean water and detergent.

D. Always wear goggles and other protective equipment as recommended by the Chemical Manufacturer.

E. Properly dispose of chemical container and unused chemicals.

MAINTENANCE:

4. Before servicing or making any adjustments to the Sprayer:

A. Stop the vehicle and set the parking brake.

B. Shut off the vehicle's engine and remove the key from ignition.

C. Disengage all power and wait until all moving parts have stopped.

5. Keep all nuts, bolts, and other fasteners tightened securely. Replace any shields removed during servicing or adjustments.

6. To be sure of optimum performance and safety, always purchase genuine TORO replacement parts. Accessories made by other manufacturer's could be dangerous. Altering this equipment in any other manner may affect the machine's operation, performance, and durability, or its use may result in injury or death. Such use could void the product warranty of The Toro Company.

CONTROLS AND OPERATION

CONSOLE (FIG. 1):

1. INDIVIDUAL BOOM VALVES: Allows individual selection of Boom sections and controls the flow of spray solution to left, center, and right Booms and works in series with Master Boom Valve. When the lever is in the down position the Boom Section Valve is on. When "OFF", flow is directed back to the tank.

2. PRESSURE CONTROL VALVE: Determines application rate by regulating amount of fluid that is bypassed to tank or pump suction. Turn clockwise to INCREASE or counter clockwise to DECREASE spraying pressure and application rate to the desired level.

3. MASTER BOOM VALVE: Directs spray flow to Flowmeter and Individual Boom Valves in "ON" position and to agitation in "OFF" position.

4. BOOM BYPASS VALVES: Manual adjustment to equalize restriction of the particular Boom Section when a section is turned "OFF." See FIG. 1.

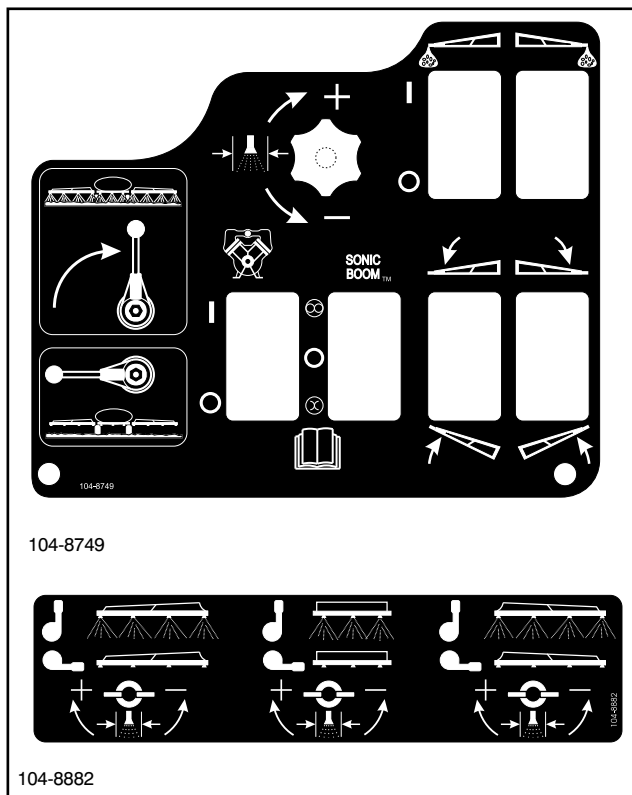

FIG. 2

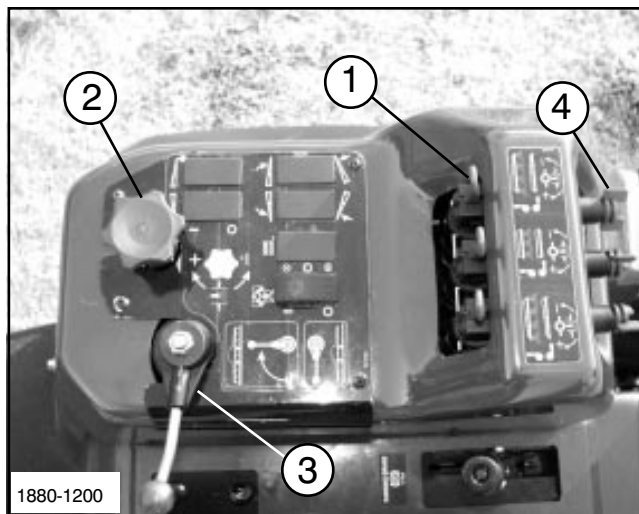

FIG. 1

- 1. Individual Boom Valves
- 2. Pressure Control Valve
- 3. Master Boom Valve
- 4. Boom Bypass Valve "OFF" Position

5. PUMP ON/OFF SWITCH: Move to "ON" position to engage the Diaphragm Pump. Move to "OFF" position to disengage Diaphragm Pump. See FIG. 2 on this page and Operating Instructions, page 22.

6. FLOWMETER: Measures amount of fluid flowing to Boom Control Valves. See FIG. 3.

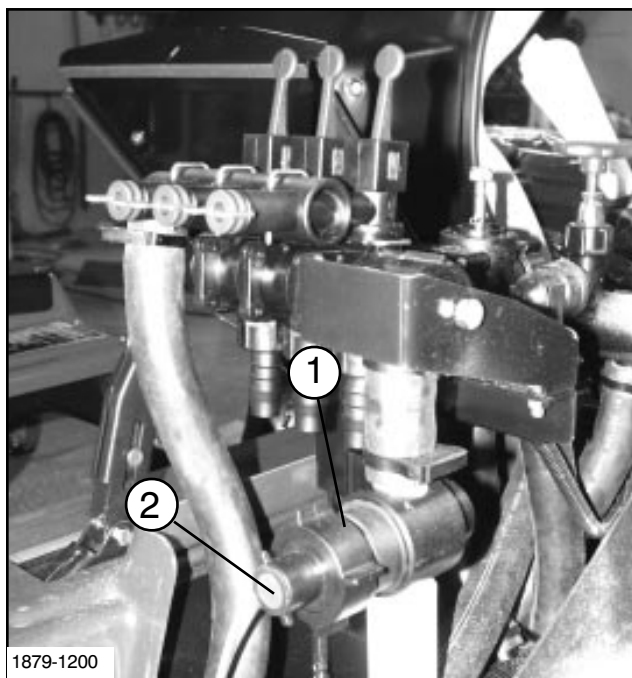

FIG. 3

- 1. Flowmeter
- 2. Indicator Light

CONTROLS AND OPERATION

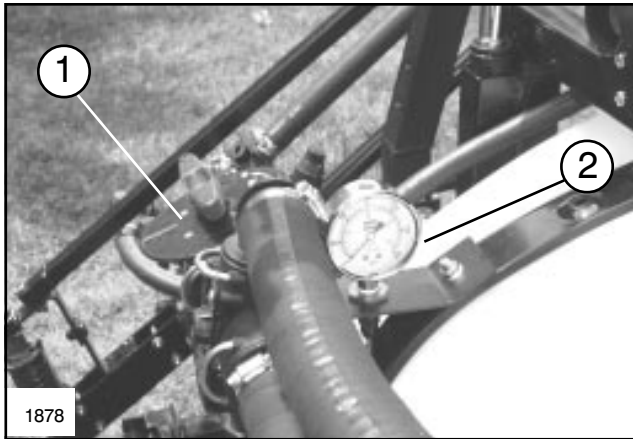

FIG. 4

1. Agitation Control Valve 2. Pressure Gauge

7. AGITATION CONTROL VALVE: Directs fluid bypassed from Pressure Control Valve to Tank Agitation or Pump Suction with minimal affect on application rate. See FIG 4.

8. PRESSURE DAMPENER: Smooths pressure pulsation in spray system. See FIG. 5.

9. SUCTION DAMPENER: Prevents Pump cavitation. See FIG. 5.

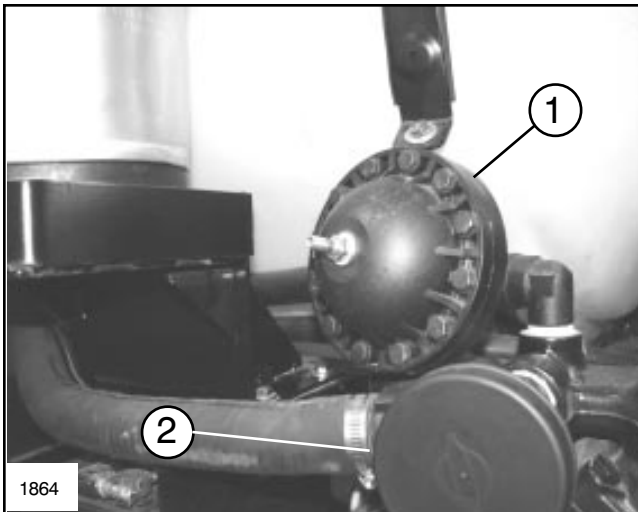

FIG. 5

1. Pressure Dampener 2. Suction Dampener

⚠ CAUTION

Chemicals can be hazardous to the environment and cause personal injury.

- Use tank drain only in a confined area.
- Follow chemical manufacturer's label and local and state regulations regarding safe disposal of tank rinsate.

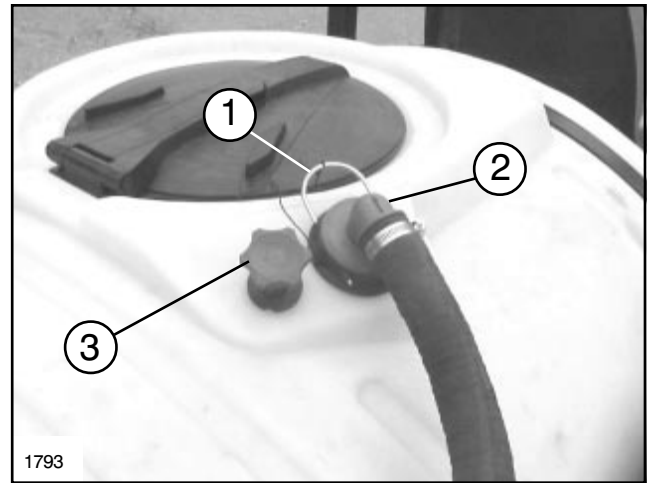

FIG. 6

1. Fork 3. Tank Drain Control Knob
2. Red Elbow

10. TANK DRAIN CONTROL: Turn knob counterclockwise to open drain valve in bottom of tank. Turn clockwise to close valve. See FIG. 6.

QUICK START SPRAY GUIDE:

1. Choose nozzle based on desired application rate and spray speed (Note: Refer to "Nozzle Selection" Section of Operator's Manual, if required).

⚠ CAUTION

In order to avoid potential for an accident or injury, choose a wide open area without obstructions to perform the following mobile spray calibration process.

2. Fill spray tank with water and drive in the speed range that will be used for spraying (Note: It is not necessary to drive at exact spraying speed).

3. Turn Spray Pump and Spray Boom "ON" to begin spraying with all three boom sections on.

4. Use the Rate Control Valve on the spray control panel to reach desired application rate on the monitor. (Note: Monitor must be in Application Rate position).

5. Turn 1 of the 3 boom sections off with Individual Boom Valves and adjust Boom Bypass Valve, if required, to maintain the application rate from step 4. (Boom Bypass Valves are located directly behind the Individual Boom Valves).

6. Repeat step 5 for remaining 2 boom sections. (This allows accurate application rate when individual boom sections are turned off)

BEFORE SPRAYING

NOZZLE SELECTION GPA/GAL/1000 FT²

See the nozzle chart on pages 52-55 to be sure that your spray nozzles have the capacity necessary to achieve the application rate selected.

To select the proper nozzle, you need to know:

1. Recommended chemical application rate in gallons per acre or gallons per 1000 sq. ft.
2. Average Vehicle speed in Miles per hour.
3. Nozzle spacing (20 inches or 50 centimeters).

With this information you can calculate the volume per minute per nozzle using the formulas to the right. Then select the proper nozzle from the following charts.

EXAMPLE (GPA FORMULA)

Application Rate = 44.6 Gallons/Acre
Vehicle Speed = 4 M.P.H.
Nozzle Spacing = 20 inches

$$\frac{44.6 \text{ G.P.A.} \times 4 \text{ M.P.H.} \times 20}{5940} = .60 \text{ G.P.M. (per nozzle)}$$

With .60 G.P.M. and a pressure of 40 psi you would select Nozzle No. 95-9224.

EXAMPLE (GAL/1000 FT² FORMULA):

Application Rate = 1.02 Gal./1000 sq. ft.
Vehicle Speed = 4 M.P.H.
Nozzle Spacing = 20 inches

$$\frac{1.02 \text{ GAL/1000 FT}^2 \times 4 \text{ M.P.H.} \times 20}{137} = .60 \text{ G.P.M. (per nozzle)}$$

With .60 GPM and a pressure of 40 psi, you would select nozzle no. 95-9224.

BEFORE SPRAYING

NOZZLE SELECTION L/HA

See the nozzle chart on pages 56 & 57 to be sure that your spray nozzles have the capacity necessary to achieve the application rate selected.

To select the proper nozzle, you need to know:

1. Recommended chemical application rate in liters per hectare.
2. Average Vehicle speed in kilometers per hour.
3. Nozzle spacing (20 inches or 50 centimeters).

With this information you can calculate the volume per minute per nozzle, using the formulas to the right.

L/HA (METRIC) FORMULA:

$$\frac{\text{L/min}}{\text{(Per nozzle)}} = \frac{\text{L/ha} \times \text{km/h} \times 50 \text{ cm}}{60,000}$$

Use L/min and Pressure to select appropriate nozzle from chart below .

EXAMPLE (L/HA FORMULA):

Application Rate = 907 L/hectare
Vehicle Speed = 5 km/h
Nozzle Spacing = 50 cm

$$\frac{907 \text{ L/ha} \times 5 \text{ km/h} \times 50}{60,000} = 3.78 \text{ L/min. (per nozzle)}$$

With 3.78 L/min and a pressure at 275 kPa you would select nozzle No. 95-9188.

BEFORE SPRAYING

SYMBOL DEFINITIONS AND CONVERSIONS

SYMBOL DEFINITIONS:

GPM	- Gallons per minute
L/min	- Liters per minute
dl/min	- Deciliter per minute
psi	- Pounds per square inch
kPa	- Kilopascal
GPA	- Gallons per acre
L/ha	- Liter per hectare
ml/ha	- Milliliter per hectare
GAL/1000 FT ²	- Gallons per 1,000 sq. ft.
mm	- Millimeters
cm	- Centimeters
dm	- Decimeters
m	- Meter
MPH	- Miles per hour
km	- Kilometers
km/h	- Kilometers per hour
US	- Volume per ACRE
SI	- Volume per HECTARE
TU	- Volume per 1,000 sq. ft.

LIQUID CONVERSIONS:

U.S. Gallons x 128 = Fluid Ounces
U.S. Gallons x 3.785 = Liters
U.S. Gallons x 0.83267 = Imperial Gallons
U.S. Gallons x 8.34 = Pounds (Water)

AREA:

1 Acre = 43,560 sq. feet
1 square meter = 10.764 sq. feet
1 hectare (ha) = 2.471 acres; 10,000 sq.meters

LENGTH:

1 millimeter (mm) = 0.039 inch
1 centimeter (cm) = 0.393 inch
1 meter (m) = 3.281 feet
1 kilometer (km) = 0.621 mile
1 inch = 25.4 millimeters; 2.54 centimeters
1 mile = 1.609 kilometers

PRESSURE:

1 psi = 6.89 kPa
1 Bar = 100 kPa

Formulas:

$$\text{Speed (mph)} = \frac{\text{Distance (ft.)} \times 60}{\text{Time (seconds)} \times 88}$$

$$\text{GPM per nozzle} = \frac{\text{GPA} \times \text{mph} \times w^*}{5,940}$$

$$\text{GPM per nozzle} = \frac{\text{Gal/1000ft}^2 \times \text{mph} \times w^*}{136}$$

$$\text{GPA} = \frac{5,940 \times \text{GPM (per nozzle)}}{\text{mph} \times w^*}$$

$$\text{Gal/1000ft.} = \frac{136 \times \text{GPM (per nozzle)}}{\text{mph} \times w^*}$$

* w= Nozzle spacing in inches.

BEFORE SPRAYING NOZZLE SELECTION CHART

Gallons Per Acre Application Rates												
Toro Part No.	Nozzle Number Color Code	Pressure (PSI)	Capacity 1 Nozzle (GPM)	Gallons per Acre at 20" Spacings								
				FIRST		SECOND			THIRD			
				2.5 MPH	3 MPH	3.5 MPH	4 MPH	4.5 MPH	5 MPH	5.5 MPH	6 MPH	
95-9221	1/4TTJ02-VS Yellow	20	0.14	16.6	13.9	11.9	10.4	9.2	8.3	7.6	6.9	
		30	0.17	20.2	16.8	14.4	12.6	11.2	10.1	9.2	8.4	
		40	0.20	23.8	19.8	17.0	14.9	13.2	11.9	10.8	9.9	
		50	0.22	26.1	21.8	18.7	16.3	14.5	13.1	11.9	10.9	
		60	0.24	28.8	24.0	20.6	18.0	16.0	14.4	13.1	12.0	
		70	0.26	31.1	25.9	22.2	19.4	17.3	15.6	14.1	13.0	
		80	0.28	33.3	27.7	23.8	20.8	18.5	16.6	15.1	13.9	
		90	0.30	35.3	29.4	25.2	22.1	19.6	17.6	16.0	14.7	
		100	0.31	37.2	31.0	26.6	23.2	20.7	18.6	16.9	15.5	
		110	0.33	39.0	32.5	27.9	24.4	21.7	19.5	17.7	16.3	
		120	0.34	40.7	33.9	29.1	25.5	22.6	20.4	18.5	17.0	
		130	0.36	42.4	35.3	30.3	26.5	23.6	21.2	19.3	17.7	
		140	0.37	44.0	36.7	31.4	27.5	24.4	22.0	20.0	18.3	
		150	0.38	45.5	38.0	32.5	28.5	25.3	22.8	20.7	19.0	
95-9222	1/4TTJ04-VS Red	20	0.28	33.3	27.7	23.8	20.8	18.5	16.6	15.1	13.9	
		30	0.35	41.6	34.7	29.7	26.0	23.1	20.8	18.9	17.3	
		40	0.40	47.5	39.6	33.9	29.7	26.4	23.8	21.6	19.8	
		50	0.45	53.5	44.6	38.2	33.4	29.7	26.7	24.3	22.3	
		60	0.48	57.6	48.0	41.2	36.0	32.0	28.8	26.2	24.0	
		70	0.52	62.2	51.9	44.5	38.9	34.6	31.1	28.3	25.9	
		80	0.56	66.5	55.4	47.5	41.6	37.0	33.3	30.2	27.7	
		90	0.59	70.6	58.8	50.4	44.1	39.2	35.3	32.1	29.4	
		100	0.63	74.4	62.0	53.1	46.5	41.3	37.2	33.8	31.0	
		110	0.66	78.0	65.0	55.7	48.8	43.3	39.0	35.5	32.5	
		120	0.69	81.5	67.9	58.2	50.9	45.3	40.7	37.0	33.9	
		130	0.71	84.8	70.7	60.6	53.0	47.1	42.4	38.5	35.3	
		140	0.74	88.0	73.3	62.9	55.0	48.9	44.0	40.0	36.7	
		150	0.77	91.1	75.9	65.1	56.9	50.6	45.5	41.4	38.0	
95-9223	1/4TTJ05-VS Brown	20	0.35	41.6	34.7	29.7	26.0	23.1	20.8	18.9	17.3	
		30	0.43	51.1	42.6	36.5	31.9	28.4	25.5	23.2	21.3	
		40	0.50	59.4	49.5	42.4	37.1	33.0	29.7	27.0	24.8	
		50	0.56	66.5	55.4	47.5	41.6	37.0	33.3	30.2	27.7	
		60	0.61	72.0	60.0	51.4	45.0	40.0	36.0	32.7	30.0	
		70	0.65	77.8	64.8	55.6	48.6	43.2	38.9	35.4	32.4	
		80	0.70	83.2	69.3	59.4	52.0	46.2	41.6	37.8	34.7	
		90	0.74	88.2	73.5	63.0	55.1	49.0	44.1	40.1	36.8	
		100	0.78	93.0	77.5	66.4	58.1	51.7	46.5	42.3	38.7	
		110	0.82	97.5	81.3	69.7	60.9	54.2	48.8	44.3	40.6	
		120	0.86	101.8	84.9	72.7	63.7	56.6	50.9	46.3	42.4	
		130	0.89	106.0	88.3	75.7	66.3	58.9	53.0	48.2	44.2	
		140	0.93	110.0	91.7	78.6	68.8	61.1	55.0	50.0	45.8	
		150	0.96	113.9	94.9	81.3	71.2	63.3	56.9	51.8	47.4	
95-9224	1/4TTJ06-VS Gray	20	0.42	49.9	41.6	35.6	31.2	27.7	24.9	22.7	20.8	
		30	0.52	61.8	51.5	44.1	38.6	34.3	30.9	28.1	25.7	
		40	0.60	71.3	59.4	50.9	44.6	39.6	35.6	32.4	29.7	
		50	0.67	79.6	66.3	56.9	49.7	44.2	39.8	36.2	33.2	
		60	0.73	86.4	72.0	61.7	54.0	48.0	43.2	39.3	36.0	
		70	0.79	93.3	77.8	66.7	58.3	51.9	46.7	42.4	38.9	
		80	0.84	99.8	83.2	71.3	62.4	55.4	49.9	45.4	41.6	
		90	0.89	105.8	88.2	75.6	66.2	58.8	52.9	48.1	44.1	
		100	0.94	111.6	93.0	79.7	69.7	62.0	55.8	50.7	46.5	
		110	0.98	117.0	97.5	83.6	73.1	65.0	58.5	53.2	48.8	
		120	1.03	122.2	101.8	87.3	76.4	67.9	61.1	55.6	50.9	
		130	1.07	127.2	106.0	90.9	79.5	70.7	63.6	57.8	53.0	
		140	1.11	132.0	110.0	94.3	82.5	73.3	66.0	60.0	55.0	
		150	1.15	136.6	113.9	97.6	85.4	75.9	68.3	---	56.9	

BEFORE SPRAYING

NOZZLE SELECTION CHART

Gallons Per Acre Application Rates											
Toro Part No.	Nozzle Number	Pressure (PSI)	Capacity 1 Nozzle (GPM)	Gallons per Acre at 20" Spacings							
	Color Code			FIRST		SECOND			THIRD		
				2.5 MPH	3 MPH	3.5 MPH	4 MPH	4.5 MPH	5 MPH	5.5 MPH	6 MPH
95-9225	1/4TTJ08-VS White	20	0.57	67.7	56.4	48.4	42.3	37.6	33.9	30.8	28.2
		30	0.69	82.0	68.3	58.6	51.2	45.5	41.0	37.3	34.2
		40	0.80	95.0	79.2	67.9	59.4	52.8	47.5	43.2	39.6
		50	0.89	105.7	88.1	75.5	66.1	58.7	52.9	48.1	44.1
		60	0.99	117.3	97.7	83.8	73.3	65.2	58.6	53.3	48.9
		70	1.07	126.7	105.6	90.5	79.2	70.4	63.3	57.6	52.8
		80	1.14	135.4	112.9	96.7	84.6	75.2	67.7	---	56.4
		90	1.21	143.6	119.7	102.6	89.8	79.8	71.8	---	59.9
		100	1.27	151.4	126.2	108.2	94.6	84.1	75.7	---	---
		110	1.34	158.8	132.3	113.4	99.3	88.2	79.4	---	---
		120	1.40	165.9	138.2	---	103.7	92.1	82.9	---	---
		130	1.45	172.6	143.9	---	107.9	95.9	86.3	---	---
		140	1.51	179.2	149.3	---	112.0	99.5	89.6	---	---
		150	1.56	185.4	154.5	---	115.9	103.0	92.7	---	---
		95-9188	1/4TTJ10-VS Light Blue	20	0.71	84.3	70.3	60.2	52.7	46.9	42.2
30	0.87			103.4	86.1	73.8	64.6	57.4	51.7	47.0	43.1
40	1.00			118.8	99.0	84.9	74.3	66.0	59.4	54.0	49.5
50	1.12			133.1	110.9	95.0	83.2	73.9	66.5	60.5	55.4
60	1.23			146.1	121.7	104.4	91.3	81.2	73.0	---	60.9
70	1.33			157.8	131.5	112.7	98.6	87.7	78.9	---	---
80	1.42			168.7	140.6	---	105.4	93.7	84.3	---	---
90	1.51			178.9	149.1	---	111.8	99.4	89.5	---	---
100	1.59			---	157.2	---	---	104.8	94.3	---	---
110	1.67			---	164.8	---	---	109.9	98.9	---	---
120	1.74			---	172.2	---	---	114.8	103.3	---	---
130	1.81			---	179.2	---	---	---	107.5	---	---
140	1.88			---	186.0	---	---	---	111.6	---	---
150	1.94			---	---	---	---	---	115.5	---	---
95-9226	1/4TTJ15-VS Light Green			20	1.06	125.9	104.9	89.9	78.7	70.0	63.0
		30	1.30	154.4	128.7	110.3	96.5	85.8	77.2	---	---
		40	1.50	178.2	148.5	---	111.4	99.0	89.1	---	---
		50	1.68	199.6	166.3	---	---	110.9	99.8	---	---
		60	1.84	---	181.8	---	---	---	109.1	---	---
		70	1.98	---	196.3	---	---	---	117.8	---	---
		80	2.12	---	---	---	---	---	---	---	---
		90	2.25	---	---	---	---	---	---	---	---
		100	2.37	---	---	---	---	---	---	---	---
		110	2.49	---	---	---	---	---	---	---	---
		120	2.60	---	---	---	---	---	---	---	---
		130	2.70	---	---	---	---	---	---	---	---
		140	2.80	---	---	---	---	---	---	---	---
		150	2.90	---	---	---	---	---	---	---	---

BEFORE SPRAYING NOZZLE SELECTION CHART

Gallons Per 1000 Sq. Ft. Application Rates											
Toro Part No.	Nozzle Number Color Code	Pressure (PSI)	Capacity 1 Nozzle (GPM)	Gallons per 1000 Sq. Ft. at 20" Spacings							
				FIRST		SECOND			THIRD		
				2.5 MPH	3 MPH	3.5 MPH	4 MPH	4.5 MPH	5 MPH	5.5 MPH	6 MPH
95-9221	1/4TTJ02-VS Yellow	20	0.14	0.38	0.32	0.27	0.24	0.21	0.19	0.17	0.16
		30	0.17	0.46	0.39	0.33	0.29	0.26	0.23	0.21	0.19
		40	0.20	0.54	0.45	0.39	0.34	0.30	0.27	0.25	0.23
		50	0.22	0.60	0.50	0.43	0.37	0.33	0.30	0.27	0.25
		60	0.24	0.66	0.55	0.47	0.41	0.37	0.33	0.30	0.27
		70	0.26	0.71	0.59	0.51	0.45	0.40	0.36	0.32	0.30
		80	0.28	0.76	0.63	0.54	0.48	0.42	0.38	0.35	0.32
		90	0.30	0.81	0.67	0.58	0.50	0.45	0.40	0.37	0.34
		100	0.31	0.85	0.71	0.61	0.53	0.47	0.43	0.39	0.35
		110	0.33	0.89	0.74	0.64	0.56	0.50	0.45	0.41	0.37
		120	0.34	0.93	0.78	0.67	0.58	0.52	0.47	0.42	0.39
		130	0.36	0.97	0.81	0.69	0.61	0.54	0.49	0.44	0.40
		140	0.37	1.01	0.84	0.72	0.63	0.56	0.50	0.46	0.42
		150	0.38	1.04	0.87	0.74	0.65	0.58	0.52	0.47	0.43
		95-9222	1/4TTJ04-VS Red	20	0.28	0.76	0.63	0.54	0.48	0.42	0.38
30	0.35			0.95	0.79	0.68	0.60	0.53	0.48	0.43	0.40
40	0.40			1.09	0.91	0.78	0.68	0.60	0.54	0.49	0.45
50	0.45			1.22	1.02	0.87	0.77	0.68	0.61	0.56	0.51
60	0.48			1.32	1.10	0.94	0.82	0.73	0.66	0.60	0.55
70	0.52			1.42	1.19	1.02	0.89	0.79	0.71	0.65	0.59
80	0.56			1.52	1.27	1.09	0.95	0.85	0.76	0.69	0.63
90	0.59			1.62	1.35	1.15	1.01	0.90	0.81	0.73	0.67
100	0.63			1.70	1.42	1.22	1.06	0.95	0.85	0.77	0.71
110	0.66			1.79	1.49	1.28	1.12	0.99	0.89	0.81	0.74
120	0.69			1.87	1.55	1.33	1.17	1.04	0.93	0.85	0.78
130	0.71			1.94	1.62	1.39	1.21	1.08	0.97	0.88	0.81
140	0.74			2.02	1.68	1.44	1.26	1.12	1.01	0.92	0.84
150	0.77			2.09	1.74	1.49	1.30	1.16	1.04	0.95	0.87
95-9223	1/4TTJ05-VS Brown			20	0.35	0.95	0.79	0.68	0.60	0.53	0.48
		30	0.43	1.17	0.97	0.84	0.73	0.65	0.58	0.53	0.49
		40	0.50	1.36	1.13	0.97	0.85	0.76	0.68	0.62	0.57
		50	0.56	1.52	1.27	1.09	0.95	0.85	0.76	0.69	0.63
		60	0.61	1.65	1.37	1.18	1.03	0.92	0.82	0.75	0.69
		70	0.65	1.78	1.48	1.27	1.11	0.99	0.89	0.81	0.74
		80	0.70	1.90	1.59	1.36	1.19	1.06	0.95	0.87	0.79
		90	0.74	2.02	1.68	1.44	1.26	1.12	1.01	0.92	0.84
		100	0.78	2.13	1.77	1.52	1.33	1.18	1.06	0.97	0.89
		110	0.82	2.23	1.86	1.59	1.40	1.24	1.12	1.01	0.93
		120	0.86	2.33	1.94	1.67	1.46	1.30	1.17	1.06	0.97
		130	0.89	2.43	2.02	1.73	1.52	1.35	1.21	1.10	1.01
		140	0.93	2.52	2.10	1.80	1.57	1.40	1.26	1.14	1.05
		150	0.96	2.61	2.17	1.86	1.63	1.45	1.30	1.19	1.09
		95-9224	1/4TTJ06-VS Gray	20	0.42	1.14	0.95	0.82	0.71	0.63	0.57
30	0.52			1.41	1.18	1.01	0.88	0.79	0.71	0.64	0.59
40	0.60			1.63	1.36	1.17	1.02	0.91	0.82	0.74	0.68
50	0.67			1.82	1.52	1.30	1.14	1.01	0.91	0.83	0.76
60	0.73			1.98	1.65	1.41	1.24	1.10	0.99	0.90	0.82
70	0.79			2.14	1.78	1.53	1.34	1.19	1.07	0.97	0.89
80	0.84			2.28	1.90	1.63	1.43	1.27	1.14	1.04	0.95
90	0.89			2.42	2.02	1.73	1.51	1.35	1.21	1.10	1.01
100	0.94			2.55	2.13	1.82	1.60	1.42	1.28	1.16	1.06
110	0.98			2.68	2.23	1.91	1.67	1.49	1.34	1.22	1.12
120	1.03			2.80	2.33	2.00	1.75	1.55	1.40	1.27	1.17
130	1.07			2.91	2.43	2.08	1.82	1.62	1.46	1.32	1.21
140	1.11			3.02	2.52	2.16	1.89	1.68	1.51	1.37	1.26
150	1.15			3.13	2.61	2.23	1.96	1.74	1.56	---	1.30

BEFORE SPRAYING NOZZLE SELECTION CHART

Gallons Per 1000 Sq. Ft. Application Rates											
Toro Part No.	Nozzle Number Color Code	Pressure (PSI)	Capacity 1 Nozzle (GPM)	Gallons per 1000 Sq. Ft. at 20" Spacings							
				FIRST		SECOND				THIRD	
				2.5 MPH	3 MPH	3.5 MPH	4 MPH	4.5 MPH	5 MPH	5.5 MPH	6 MPH
95-9225	1/4TTJ08-VS White	20	0.57	1.55	1.29	1.11	0.97	0.86	0.78	0.70	0.65
		30	0.69	1.88	1.56	1.34	1.17	1.04	0.94	0.85	0.78
		40	0.80	2.18	1.81	1.55	1.36	1.21	1.09	0.99	0.91
		50	0.89	2.42	2.02	1.73	1.51	1.34	1.21	1.10	1.01
		60	0.99	2.69	2.24	1.92	1.68	1.49	1.34	1.22	1.12
		70	1.07	2.90	2.42	2.07	1.81	1.61	1.45	1.32	1.21
		80	1.14	3.10	2.58	2.21	1.94	1.72	1.55	---	1.29
		90	1.21	3.29	2.74	2.35	2.06	1.83	1.64	---	1.37
		100	1.27	3.47	2.89	2.48	2.17	1.93	1.73	---	---
		110	1.34	3.64	3.03	2.60	2.27	2.02	1.82	---	---
		120	1.40	3.80	3.16	---	2.37	2.11	1.90	---	---
		130	1.45	3.95	3.29	---	2.47	2.20	1.98	---	---
		140	1.51	4.10	3.42	---	2.56	2.28	2.05	---	---
		150	1.56	4.25	3.54	---	2.65	2.36	2.12	---	---
		95-9188	1/4TTJ10-VS Light Blue	20	0.71	1.93	1.61	1.38	1.21	1.07	0.97
30	0.87			2.37	1.97	1.69	1.48	1.31	1.18	1.08	0.99
40	1.00			2.72	2.27	1.94	1.70	1.51	1.36	1.24	1.13
50	1.12			3.05	2.54	2.18	1.90	1.69	1.52	1.38	1.27
60	1.23			3.34	2.79	2.39	2.09	1.86	1.67	---	1.39
70	1.33			3.61	3.01	2.58	2.26	2.01	1.81	---	---
80	1.42			3.86	3.22	---	2.41	2.15	1.93	---	---
90	1.51			4.10	3.41	---	2.56	2.28	2.05	---	---
100	1.59			---	3.60	---	---	2.40	2.16	---	---
110	1.67			---	3.77	---	---	2.52	2.26	---	---
120	1.74			---	3.94	---	---	2.63	2.37	---	---
130	1.81			---	4.10	---	---	---	2.46	---	---
140	1.88			---	4.26	---	---	---	2.55	---	---
150	1.94			---	---	---	---	---	2.64	---	---
95-9226	1/4TTJ15-VS Light Green			20	1.06	2.88	2.40	2.06	1.80	1.60	1.44
		30	1.30	3.54	2.95	2.53	2.21	1.96	1.77	---	---
		40	1.50	4.08	3.40	---	2.55	2.27	2.04	---	---
		50	1.68	4.57	3.81	---	---	2.54	2.28	---	---
		60	1.84	---	4.16	---	---	---	2.50	---	---
		70	1.98	---	4.49	---	---	---	2.70	---	---
		80	2.12	---	---	---	---	---	---	---	---
		90	2.25	---	---	---	---	---	---	---	---
		100	2.37	---	---	---	---	---	---	---	---
		110	2.49	---	---	---	---	---	---	---	---
		120	2.60	---	---	---	---	---	---	---	---
		130	2.70	---	---	---	---	---	---	---	---
		140	2.80	---	---	---	---	---	---	---	---
		150	2.90	---	---	---	---	---	---	---	---

BEFORE SPRAYING

NOZZLE SELECTION CHART

Liters Per Hectare Application Rates											
TORO Part No.	Nozzle Number	Pressure (kPa)	Capacity 1 Nozzle (L/min)	Liters per Hectare at 50 cm Spacings							
	Color Code			FIRST		SECOND			THIRD		
				4 km/h	5 km/h	6 km/h	7 km/h	8 km/h	9 km/h	10 km/h	11 km/h
95-9221	1/4TTJ02-VS Yellow	150	0.56	168	135	112	96	84	75	67	61
		200	0.65	194	156	130	111	97	86	78	71
		275	0.76	228	182	152	130	114	101	91	83
		350	0.86	257	206	171	147	129	114	103	94
		415	0.93	280	224	187	160	140	124	112	102
		480	1.00	301	241	201	172	151	134	120	110
		555	1.08	324	259	216	185	162	144	130	118
		630	1.15	345	276	230	197	173	153	138	125
		705	1.22	365	292	243	209	183	162	146	133
		780	1.28	384	307	256	219	192	171	154	140
		855	1.34	402	322	268	230	201	179	161	146
		930	1.40	419	335	280	240	210	186	168	152
1005	1.45	436	349	291	249	218	194	174	158		
1080	1.51	452	361	301	258	226	201	181	164		
95-2222	1/4TTJ04-VS Red	150	1.12	335	268	223	191	167	149	134	122
		200	1.29	386	309	258	221	193	172	155	140
		275	1.51	453	362	302	259	227	201	181	165
		350	1.70	511	409	341	292	256	227	204	186
		415	1.85	556	445	371	318	278	247	223	202
		480	1.99	598	479	399	342	299	266	239	218
		555	2.15	644	515	429	368	322	286	257	234
		630	2.29	686	549	457	392	343	305	274	249
		705	2.42	725	580	484	414	363	322	290	264
		780	2.54	763	610	509	436	381	339	305	277
		855	2.66	799	639	533	456	399	355	320	290
		930	2.78	833	666	555	476	417	370	333	303
1005	2.89	866	693	577	495	433	385	346	315		
1080	2.99	898	718	598	513	449	399	359	326		
95-2223	1/4TTJ05-VS Brown	150	1.12	335	268	223	191	167	149	134	122
		200	1.29	386	309	258	221	193	172	155	140
		275	1.87	561	449	374	321	281	249	224	204
		350	2.11	633	506	422	362	316	281	253	230
		415	2.30	689	551	459	394	345	306	276	251
		480	2.47	741	593	494	424	371	329	296	270
		555	2.66	797	638	531	455	398	354	319	290
		630	2.83	849	679	566	485	425	377	340	309
		705	2.99	898	719	599	513	449	399	359	327
		780	3.15	945	756	630	540	472	420	378	344
		855	3.30	989	791	659	565	495	440	396	360
		930	3.44	1032	825	688	590	516	459	413	375
1005	3.57	1072	858	715	613	536	477	429	390		
1080	3.71	1112	889	741	635	556	494	445	404		
95-2224	1/4TTJ06-VS Gray	150	1.68	503	402	335	287	251	224	201	183
		200	1.94	581	465	387	332	290	258	232	211
		275	2.27	681	545	454	389	341	303	272	248
		350	2.56	768	615	512	439	384	341	307	279
		415	2.79	837	669	558	478	418	372	335	304
		480	3.00	900	720	600	514	450	400	360	327
		555	3.22	967	774	645	553	484	430	387	352
		630	3.44	1031	825	687	589	515	458	412	375
		705	3.63	1090	872	727	623	545	485	436	396
		780	3.82	1147	918	765	655	573	510	459	417
		855	4.00	1201	961	801	686	600	534	480	437
		930	4.17	1252	1002	835	716	626	557	501	455
1005	4.34	1302	1041	868	744	651	579	521	473		
1080	4.50	1350	1080	900	771	675	600	---	491		

BEFORE SPRAYING NOZZLE SELECTION CHART

Liters Per Hectare Application Rates											
TORO Part No.	Nozzle Number Color Code	Pressure (kPa)	Capacity 1 Nozzle (L/min)	Liters per Hectare at 50 cm Spacings							
				FIRST		SECOND			THIRD		
				4 km/h	5 km/h	6 km/h	7 km/h	8 km/h	9 km/h	10 km/h	11 km/h
95-2225	1/4TTJ08-VS White	150	2.23	669	535	446	382	335	297	268	243
		200	2.58	773	618	515	442	386	343	309	281
		275	3.02	906	725	604	518	453	403	362	329
		350	3.41	1022	818	681	584	511	454	409	372
		415	3.71	1113	890	742	636	556	495	445	405
		480	3.99	1197	958	798	684	598	---	479	435
		555	4.29	1287	1030	858	735	644	---	515	468
		630	4.57	1371	1097	914	784	686	---	---	499
		705	4.84	1451	1161	967	829	725	---	---	---
		780	5.09	1526	1221	1017	872	763	---	---	---
		855	5.33	1598	1278	---	913	799	---	---	---
		930	5.55	1666	1333	---	952	833	---	---	---
		1005	5.77	1732	1386	---	990	866	---	---	---
1080	5.98	---	1436	---	1026	898	---	---	---		
95-9188	1/4TTJ10-VS Light Blue	150	2.79	838	670	558	479	419	372	335	305
		200	3.22	967	774	645	553	484	430	387	352
		275	3.78	1134	907	756	648	567	504	454	412
		350	4.26	1279	1023	853	731	640	---	512	465
		415	4.64	1393	1114	929	796	697	---	---	507
		480	4.99	1498	1199	999	856	749	---	---	---
		555	5.37	1611	1289	---	921	805	---	---	---
		630	5.72	1716	1373	---	981	858	---	---	---
		705	6.05	---	1453	---	---	908	---	---	---
		780	6.37	---	1528	---	---	955	---	---	---
		855	6.67	---	1600	---	---	1000	---	---	---
		930	6.95	---	1668	---	---	---	---	---	---
		1005	7.23	---	1734	---	---	---	---	---	---
1080	7.49	---	---	---	---	---	---	---	---		
95-9226	1/4TTJ15-VS Light Green	150	4.19	1256	1005	838	718	628	---	503	457
		200	4.84	1451	1160	967	829	725	---	---	---
		275	5.67	1701	1361	---	972	851	---	---	---
		350	6.40	---	1535	---	---	959	---	---	---
		415	6.97	---	1672	---	---	1045	---	---	---
		480	7.49	---	---	---	---	---	---	---	---
		555	8.05	---	---	---	---	---	---	---	---
		630	8.58	---	---	---	---	---	---	---	---
		705	9.08	---	---	---	---	---	---	---	---
		780	9.55	---	---	---	---	---	---	---	---
		855	10.00	---	---	---	---	---	---	---	---
		930	10.43	---	---	---	---	---	---	---	---
		1005	10.84	---	---	---	---	---	---	---	---
1080	11.24	---	---	---	---	---	---	---	---		

BEFORE SPRAYING

FILL FRESH WATER WASH TANK (See FIG. 1):

In case of chemical contact with skin or eyes, a fresh water wash tank has been installed on the left side of the vehicle. Refer to the Chemical Manufacturer's label for instructions on seeking medical attention.

NOTE: Fill Fresh Water Wash Tank each day of operation with clean water only. Check to assure tank is full before each operation.



FIG. 1

1. Fresh Water Tank

2. Spigot

1. Turn Tank Spigot to on position.

2. Hold contaminated area directly in water stream. Flush thoroughly.

FILLING THE SOLUTION TANK:



CAUTION

CHEMICALS ARE HAZARDOUS AND CAN CAUSE PERSONAL INJURY!

- Carefully read the directions printed on the chemical manufacturer's labels before handling chemicals. Instructions on chemical manufacturer's container labels, regarding mixing proportions, should be read and strictly followed.
- Keep spray material away from skin. If spray material comes in contact with body, wash it off immediately with clean water and detergent.
- Always wear goggles and other protective equipment as recommended by the Chemical Manufacturer.

IMPORTANT: Follow the chemical manufacturer's instructions for mixing spray solution to obtain desired application rate. Do not add chemical to Tank until just before use. The concentrate should not be poured into an empty Tank: Fill tank about 3/4 full with clean clear water. With agitation ON, add chemical concentrate slowly and finish filling Tank with water.

NOTE: When using water-soluble bags; Fill chemical tank 1/2 full of clean, clear water, then place water-soluble bags in Tank Strainer and use anti-siphon device to finish filling tank through tank strainer.

DO NOT PLACE WATER-SOLUBLE BAGS DIRECTLY INTO TANK.

Premix wettable powders in one or two 5-gallon containers, then slowly add premix to 3/4 tank of clean clear water with agitation ON.

SPRAY PRO™ CONSOLE FUNCTIONS

The Spray Pro™ features a large easy-to-read liquid crystal display, lighted selection dial and lighted panel for night use.

NOTE: The Spray Pro™ is preprogrammed with values for speed, flow, and width calibrations. The initial measurement units are US gallons per acre, which can be changed.

SPEED: Displays ground speed in miles per hour (kilometers per hour).

TEST SPEED: Used to simulate ground speed for pre-field checkout.

APPLICATION RATE: Displays gallons (liters) of liquid applied per acre (hectare).

CALIBRATION FLOW: Displays total number of gallons (liters) passed through the flowmeter while in Run Mode. Primarily used in flowmeter fine-tuning. May be reset.

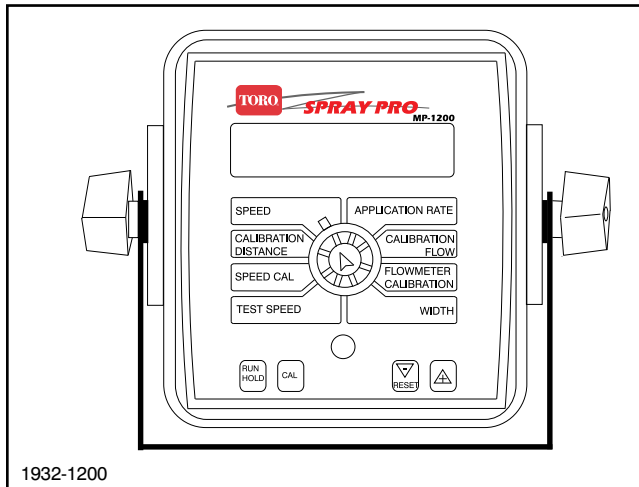

FIG. 1

WIDTH: Used in calibration mode to enter the working width of your sprayer.

CALIBRATION DISTANCE: Displays distance traveled in feet (meters), while in Run Mode. May be reset.

SPEED CAL: Used in calibration mode to enter the speed calibration value.

FLOWMETER CAL: Used to enter the calibration value for the flowmeter.

KEY FUNCTIONS:

RUN/HOLD: Key for manual operation of Spray Pro™. Changes status from Run to Hold.

CAL: This key is used to enter and exit the Calibration Mode.

PROGRAM KEYS: Used to calibrate the system.

- **RESET** clears the selected counter when held for three seconds.

- The "+" key increases the figure displayed in the readout, while "-" decreases it when in CAL.

WARNING LIGHT: When in CAL mode, light should be constant.

SPRAY PRO™ SET-UP

US, METRIC, OR TURF UNITS:

Spray Pro™ is capable of displaying information in US (gallons per acre), METRIC (liters per hectare), or TURF (gallons per 1000 sq. ft.) measurement. The initial setting is for US measurement.

To activate the US mode, if the mode has been changed, turn the ignition switch "OFF" and place the rotary switch at "SPEED." Hold down both the "CAL" and "-" keys and turn the ignition switch "ON." The console will display US measurements. Once powered up, release the two keys. To "lock-in" US mode you must enter calibration. Press and HOLD the CAL key until "CAL" lights on the display. The console is now in calibration and US mode is locked-in. Exit CAL by pressing and holding the "CAL" key until CAL disappears from the display (approximately 3 seconds).

To activate the Metric mode, turn ignition switch "OFF" and place the rotary switch at "APPLICATION RATE." Hold down both the "CAL" and "-" keys and turn power ON (See FIG. 2). The console will display Metric measurements. Once powered up, release the two keys. To "lock-in" Metric mode you must enter calibration. Press and HOLD the CAL key until "CAL" lights on the display. The console is now in calibration and Metric mode is locked-in. Exit CAL by pressing and holding the "CAL" key until CAL disappears from the display (approximately 3 seconds).

NOTE: In metric, the width will have a decimal point, in US there is no decimal point. Also, changing from US to Metric mode may change or alter any previously entered calibration values. After switching measurement modes, confirm that all calibration values are correct.

To activate the Turf mode, turn the ignition switch "OFF" and place the rotary switch at "CALIBRATION FLOW." Hold down both the "CAL" and "-" Keys and turn the ignition switch "ON." The console will display Turf measurement. Once powered up, release the two Keys. To "lock-in" Turf mode you must enter calibration. Press and HOLD the CAL Key until "CAL" light on the display. The console is now in calibration and Turf mode is locked-in. Exit CAL by pressing and holding the "CAL" Key until CAL disappears from the display (approximately 3 seconds).

In All Calibration Operations:

1. Place the console in HOLD by using the Run/Hold Key.
2. Press and hold the "CAL" key for three seconds to select the calibration mode. The console display will read "CAL" (See FIG. 2), and the red warning light will turn on.

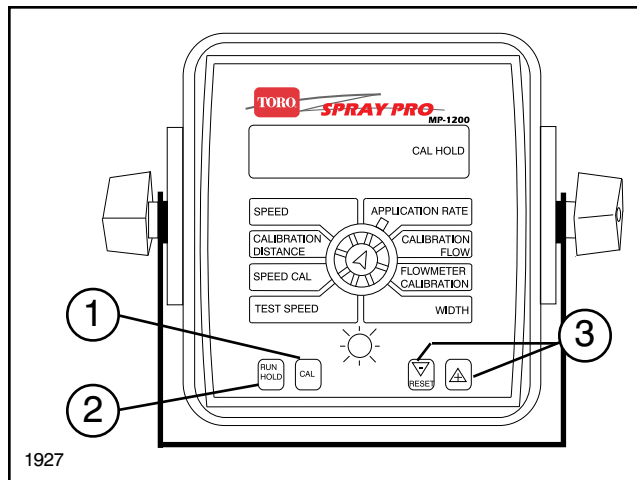

FIG. 2

1. Calibration Mode
2. Run/Hold
3. Program Keys

3. Turn the rotary dial to the desired "CAL" position. Then use the "+" and "-" keys to adjust the displayed value up or down as needed.

4. Hold the "CAL" key again for three seconds to exit calibration. "CAL" will disappear from the display.

NOTE: The display will flash alternately between Calibration distance and speed calibration when in the SPEED CALIBRATION position, or calibration flow and flowmeter calibration when in the FLOWMETER CALIBRATION position. When "+" or "-" is pressed, the display will "hold" the item that was displayed when that key was pressed. The display will resume alternation after 64 seconds of no key being depressed. Please refer to calibration section for details.

CALIBRATION VALUES:

The Spray Pro™ comes programmed with values for speed, flow, and width calibrations. However the Flowmeter and speed sensor calibrations should be fine-tuned for optimum performance.

WIDTH:

The Boom Width is preprogrammed for 220" (11 nozzles at 20" spacing). This value does not need to be changed unless nozzles are added or disabled. The value can be changed by placing the console in Hold with the Run/Hold key, enter the calibration mode, then turn the dial to the WIDTH position and use the "+" and "-" keys to adjust the Boom Width. Pressing the "CAL" key again will exit the calibration mode.

SPRAY PRO™ CALIBRATION

FINE TUNING FLOWMETER SET-UP:

This procedure is used to verify and fine-tune the flowmeter calibration. This procedure would be repeated when the flowmeter installation has been altered.

PROCEDURE:

1. Put enough water in the sprayer tank to perform this test. (Preferably 100 gallons or more. The larger the volume of water used, the more accurate will be the calibration.)

2. Start sprayer pump and turn on booms. Run enough water to purge all air from lines. Turn off booms but leave pump running.

3. Place monitor in Hold mode and turn console rotary selector to the CALIBRATION FLOW position. Press and hold the RESET button until the display reads 0 (about 3 seconds).

4. Switch the monitor to Run Mode and turn on booms and run a known amount* of water (preferable 100 gallons or more) through the flowmeter and out the nozzles.

5. Turn off booms and switch the monitor to Hold mode. Compare the console's CALIBRATION FLOW reading with the known amount of water run. If the two amounts are the same, no fine tuning is required. If the two amounts are different, continue with the next step.

6. With the console in the FLOWMETER CALIBRATION position, enter calibration (console in HOLD, hold CAL until red light comes on; about three seconds). The display will alternate (at about three second intervals) between the flowmeter calibration value and the CALIBRATION FLOW value. (To tell which is which, watch for the word "CAL" on display. It will be present with the flowmeter calibration value but not with the CALIBRATION FLOW value).

7. When the CALIBRATION FLOW value is displayed, use the "+" or "-" button to adjust the value to match the amount of water run.

8. Once the display again begins alternating, you will notice that the flowmeter calibration value has changed. If the CALIBRATION FLOW value is correct, write down the new flowmeter calibration value. This is your "fine tuned" calibration value. Keep it for future reference.

9. Exit calibration by holding "CAL" until the console's red light goes out (about three seconds).

*The most accurate method to measure the volume of water run is to place a container under EVERY nozzle and add together the amount from each nozzle. This assures that 100 percent of the water is collected and that all nozzles are spraying equally. It is important to perform this procedure at a flow rate similar to that which will be used in the field.

FINE TUNING SPEED SENSOR SET-UP:

1. Verify proper tire pressure, fill the spray tank half full with clear water and fill the fresh water tank.

2. Select a straight tract of ground that is similar to your actual turf conditions and as level as possible. Mark a distance of at least 500 feet with clear indicators at the beginning and end of the course.

3. Turn the Pump ON/OFF Switch to OFF. Place the monitor in HOLD mode with the RUN/HOLD button. Turn the rotary dial to the CALIBRATION DISTANCE position. Push and hold the RESET button for 3 seconds to verify that the distance counter is set to zero.

4. Drive the vehicle through the measured distance using the RUN/HOLD Button to start and stop the distance counter at the beginning and end of the course. The displayed number on the monitor should begin increasing when the monitor goes to RUN mode. Begin driving the course well ahead of the start point and drive past the end point. Stop in a level and safe area to continue with this procedure.

5. Compare the monitor's distance reading with the actual distance driven (course distance). If the two amounts are the same, no fine-tuning is required. If the two amounts are different, continue with the next step.

6. Space the monitor to the SPEED CAL position and enter calibration mode (monitor in hold, hold CAL until red light comes on; about three seconds). The display will alternate (at about three second intervals) between the SPEED CAL value and the CALIBRATION DISTANCE value. (When the words CAL and HOLD appear, the number displayed is the SPEED CAL value. When only the word HOLD appears, that is the CALIBRATION DISTANCE value.)

7. When the CALIBRATION DISTANCE value is displayed, use the "+" and "-" keys to adjust the value to match the actual distance driven.

8. Once the display again begins alternating (after 64 seconds of not pushing any keys), you will notice that the SPEED CAL value has changed. If the calibration distance value is correct, write down the new SPEED CAL value. This is your "fine tuned" calibration value. Keep it for future reference.

9. Exit calibration by holding CAL until the red light goes out (about three seconds).

SPRAY PRO™ SET-UP

OPERATION:

The Spray Pro™ monitor features a large easy-to-read liquid crystal display with lighted display, and panel lighting for night use. To get a readout of any of the monitored functions, simply turn the rotary selector to the desired item. The console gives a continuous readout of the function selected until another one is chosen.

EXAMPLES (See FIG. 4):

To display your speed in miles per hour (kilometers per hour), turn the dial to SPEED.

To measure distance in feet (meters), turn the dial to CALIBRATION DISTANCE.

To monitor gallons applied per acre (liters per hectare), turn the dial to APPLICATION RATE.

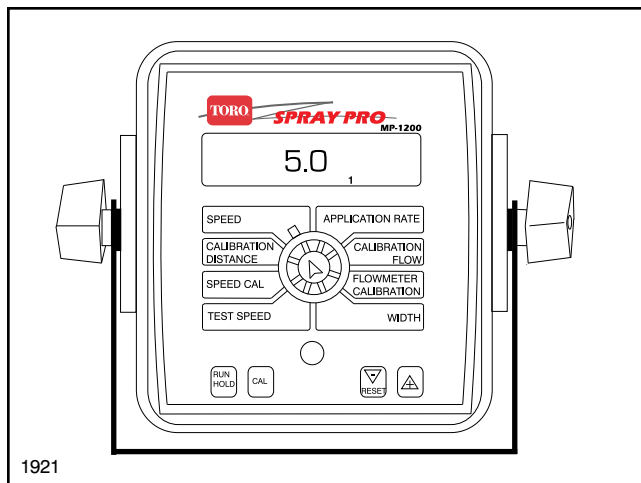

FIG. 4

OVERFLOW MESSAGE:

If the display message "OFL" appears during calibration distance or calibration flow measurement, it indicates that the readout's capacity to display information has been exceeded, and the affected function must be reset to "0" to continue counting.

RESETTING COUNTERS:

To reset the CALIBRATION DISTANCE or CALIBRATION FLOW counter, first put system in hold. Turn the dial to the appropriate item and press the "RESET" key for approximately three seconds, until the display's read out automatically returns to zero.

RUN/HOLD KEY:

The Spray Pro™ Monitor should usually be left in Run Mode while spraying (see Figure 4). SPEED and APPLICATION RATE will be active in Run Mode. Use HOLD mode for calibrating the sprayer and fine-tuning the FLOWMETER.

TEST SPEED:

Test speed is a built-in ground speed simulator that is used in performing pre-spraying checks. When a typical operating speed is entered, Spray Pro™ will respond as if you were actually driving that speed. It allows you to simulate your spraying application with plain water, while remaining stationary, to make certain that all of the equipment is operating properly and that your sprayer can actually perform the intended application.

To enter a test speed, place the console in TEST SPEED position, enter calibration, and use the "+" and "-" keys to enter the desired speed. Turn the Master and Individual Boom Valves on, and place the Spray Pro™ in Run Mode to begin spraying. APPLICATION RATE can be selected as normally. Test speed is automatically overridden when real motion is detected by the speed sensor.

SPRAYER CALIBRATION

IMPORTANT: INSPECT AND CLEAN ALL SYSTEM COMPONENTS BEFORE SPRAYING, INCLUDING THE TANK, STRAINER, PUMP, BOOM, PRESSURE CONTROL VALVE, AND NOZZLES, IN YOUR INSPECTION

CAUTION

In order to avoid potential for an accident or injury, choose a wide open area without obstructions to perform the following mobile spray calibration process.

1. Attach Supply Hose to Anti-siphon device and fill the Tank half full with clean clear water.
2. Follow the nozzle selection method on page 50 to select the proper nozzle for the desired application rate, operating pressure and target speed.
3. Drive the Vehicle in the desired Shift Range and at the target operating speed with the Pump and all Boom Sections on. Use the Pressure Control Valve to obtain the desired application rate on the Spray Pro™. When the desired rate is obtained, verify that the spray pressure is within the operating range for the nozzle being used. Continue with boom bypass valve adjustment if never performed or nozzles have been changed.

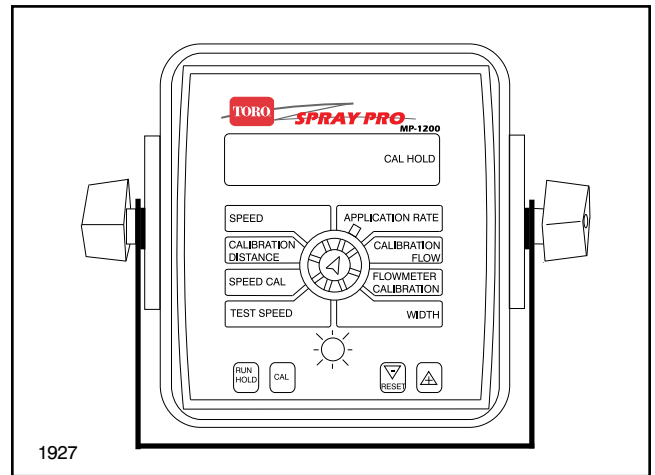

FIG. 6

4. While continuing to drive the vehicle and spraying with the monitor in the APPLICATION RATE position (see FIG 6), turn 1 of the 3 boom sections off with Individual Boom Valves and adjust Boom Bypass Valve, if required, to maintain the application rate from step 3 above. Boom Bypass Valves are located directly behind the Individual Boom Valves.
5. Repeat Step 1 for remaining 2 boom sections (this allows accurate application rate when Individual Boom Sections are turned off).

NOTES:

SPRAYER OPERATION

USING THE SPRAYER:

1. With Spray Pump switch "ON" and Master Boom Valve "OFF"; drive the vehicle to the area to be sprayed.
2. With spray system calibrated as described in Sprayer Calibration, page 61-63, operate the machine at the target speed and use the Master Boom Valve to control the spray. Use the Individual Boom Valves to control individual boom sections.
3. Variations in speed will automatically be compensated to keep the application rate constant.
4. Use the Agitation Control Valve to turn the Agitation Jets on or off. If foaming in the tank is a problem as the solution level gets low, the agitation jets can be turned off to reduce foaming. Use the pressure control valve to compensate for a slight change in application rate with the agitation jets turned off.
5. Switching the agitation off will also allow the pump to empty the tank more completely.

WHILE OPERATING THE SPRAYER:

- Do not overlap areas that have been sprayed previously.
- Watch for plugged Nozzles. Replace all worn Nozzles or those producing streaks or uneven patterns
- In general, stop the spray flow before stopping the vehicle. In a panic stop, the spray will stop automatically when the vehicle is stopped.
- Best results will be obtained if the vehicle is moving before the spray flow is turned on.
- For close quarters operation, use first gear and accelerate quickly before turning the spray flow on.



WARNING

CHEMICALS ARE HAZARDOUS AND CAN CAUSE PERSONAL INJURY!

- **Carefully read the directions printed on the chemical manufacturer's labels before handling chemicals. Instructions on chemical manufacturer's container labels regarding mixing proportions should be read and strictly followed.**
- **Keep spray material from skin. If spray material comes in contact with body, wash it off immediately with clean water and detergent.**
- **Always wear goggles and other protective equipment as recommended by the Chemical Manufacturer.**

PREVENTIVE MAINTENANCE

Preventive maintenance is most important to assure long life of the Spray System. Preventive maintenance will pay off many times over in peak performance and effective operation. The following maintenance procedures should be followed on a regular basis:

1. Flush the entire spraying system after each use. Failure to clean the system can result in a chemical residue which can plug the Hoses and/or Nozzle Tips, Pressure Control Valve, or Individual Boom Valves.
2. Wash spray nozzles thoroughly with water. Using compressed air, blow out orifice clean and dry. If orifice remains clogged, clean it with a soft bristled brush. Never use a metal object.
3. Check all of the nozzles frequently to spot any inconsistencies in the spray pattern. Worn nozzle orifices which allow a greater volume of spray material to flow through the nozzle can cause an expensive loss in chemical and/or turf damage.

SUCTION STRAINER:

Remove fork in red elbow at top of the tank. (See FIG. 1) Pull elbow out of filter housing. Remove the strainer (See FIG. 2) and clean daily when spraying wetttable powders; after every 50 hours when using liquid chemical.

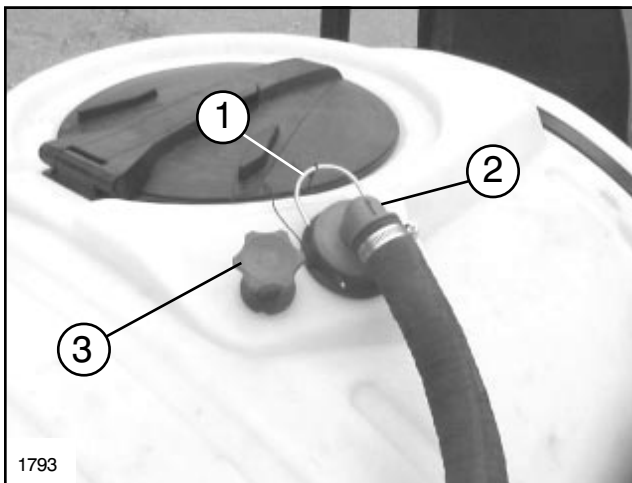

FIG. 1

1. Fork
2. Red Elbow
3. Tank Drain Control Knob

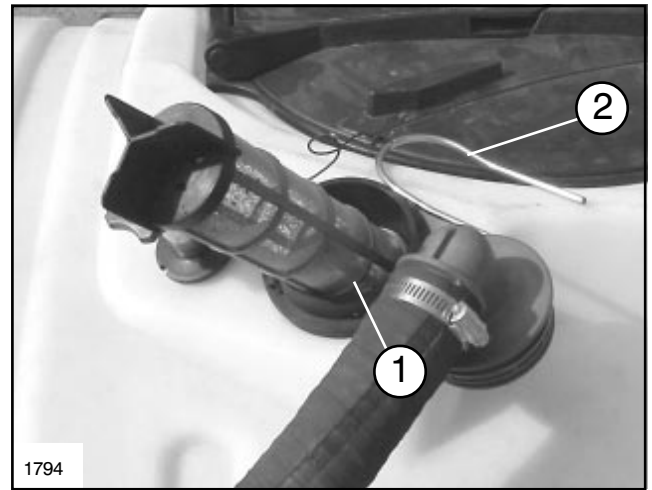

FIG. 2

1. Strainer
2. Fork

AFTER SPRAYING:

It is extremely important to carefully wash and clean the Sprayer after **every** use. The Tank, Pump, Hoses, Nozzles, Screens, Controls, Accessories, and the exterior of the Sprayer should all be cleaned.

Clean sprayer ensuring all metal parts are thoroughly clean. In some cases, use of a neutralizing agent is recommended. Recoat unpainted metal parts with a rust inhibitor. Lubricate the sprayer. Periodically check the sprayer for corrosion and treat when necessary.

FLUSH PUMP AFTER USE:

One of the most common causes for faulty pump performance is "gumming" or corrosion inside the pump. Flush the Pump and entire system with a Tank cleaning agent. Mix according to the manufacturer's directions. This will dissolve most residue remaining in the pump, leaving the inside of the pump clean for the next use.

A **minimum** of three 50 gallon rinses are usually required for all components of the Sprayer. The addition of a detergent cleaner may be advisable.

PUMP MAINTENANCE



WARNING

Fluids under high pressure can penetrate the human skin and can cause severe injury, possibly resulting in amputation or death.

- Hot liquids and chemicals can also cause burns or injury.
- DO NOT at any time place hand or any other part of the body in front of spray stream.
- If any part of the body comes in contact with the spray stream, immediately consult a physician.

CHANGING OF VALVES AND DIAPHRAGMS:

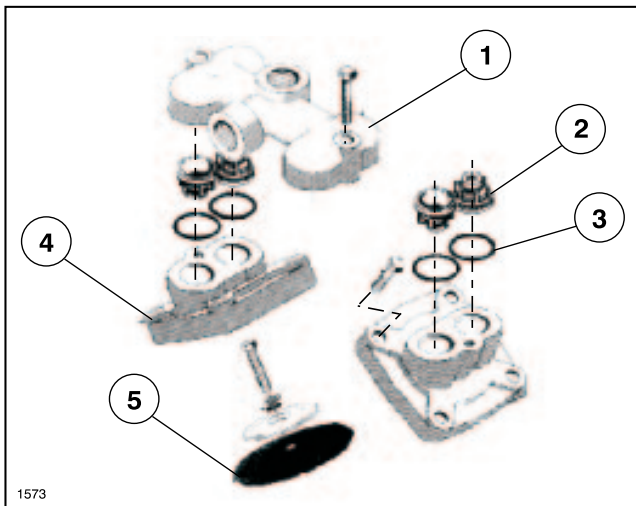

FIG. 3

- | | |
|----------------------|--------------------|
| 1. Valve Compartment | 4. Diaphragm Cover |
| 2. Valves | 5. Diaphragm |
| 3. Gaskets | |



WARNING

- BOLTS SECURING THE VALVE COMPARTMENT ARE WHITWORTH THREAD TYPE. DO NOT SUBSTITUTE ENGLISH OR METRIC THREAD BOLTS.

VALVES:

Dismantle valve compartment. Before changing the valves, note the orientation of the valves so that they may be replaced correctly. It is recommended to use new gaskets when changing or checking valves, and tighten bolts securely.

DIAPHRAGM:

If fluid is seen coming-out of the Weep Hole at the bottom of the Pump, a Diaphragm has ruptured and must be replaced.

Remove the Diaphragm cover after having dismantled the valve compartment as indicated in FIG. 3. The diaphragm may then be changed. If fluids have reached the crankcase it is strongly recommended to lubricate the entire pump with ample amount of grease.

PUMP LUBRICATION:

Once or twice during the season, depending on how often the sprayer is used, it is recommended to lubricate the pump with 2-3 pumps from a grease gun of a high quality multipurpose grease. (See FIG. 4)

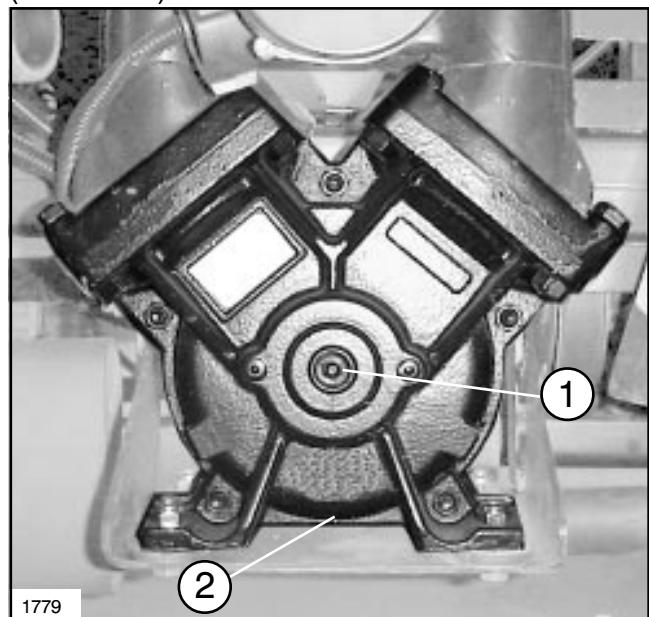

FIG. 4

- | |
|------------------------------|
| 1. Lubrication Point on Pump |
| 2. Weep Hole |

SUCTION AND PRESSURE DAMPENER MAINTENANCE:

It is normal for the Suction Dampener to move when fluid is being pumped. A tear or rupture in the Dampener can cause a suction leak. The Pump will not operate properly in this condition. Replace the Dampener if it's ruptured.

MAINTENANCE

BOOM BYPASS VALVE:

REPLACE O-RING:

IMPORTANT: Before performing any maintenance, make sure line pressure is relieved and engine is shut off.

1. Unscrew the Adjustment Knob. Replace O-Ring.
2. Replace Adjustment Knob.

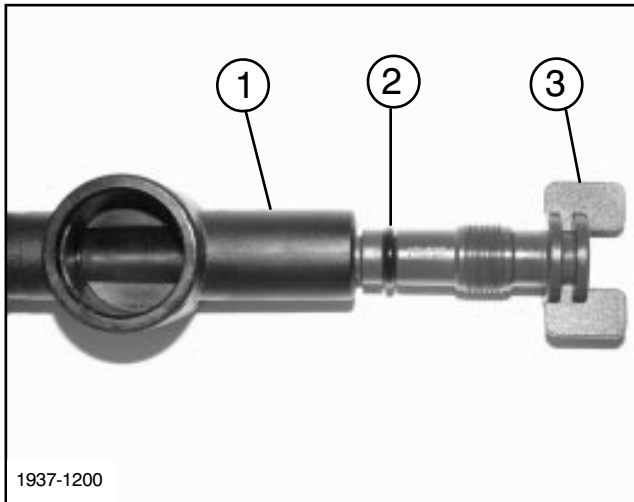

FIG. 5

1. Distribution Valve Assembly
2. O-Ring
3. Adjustment Knob

PRESSURE DAMPENER (SEE FIG. 6):

1. Dampener operates most effectively with 0 psi precharge.
2. If fluid is present when Air Pressure is checked, the Diaphragm has ruptured.
3. Diaphragm in Dampener can be changed by removing the bolts holding the Dampener halves together, replacing the Diaphragm, and reassembling.

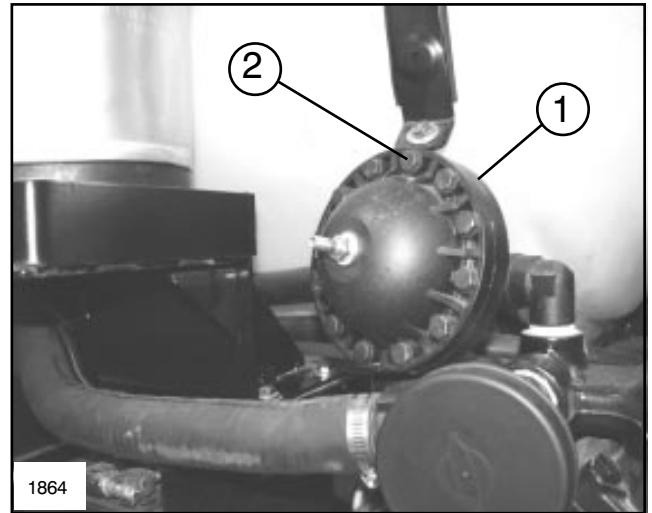

FIG. 6

1. Pressure Dampener
2. Bolts

MAINTENANCE

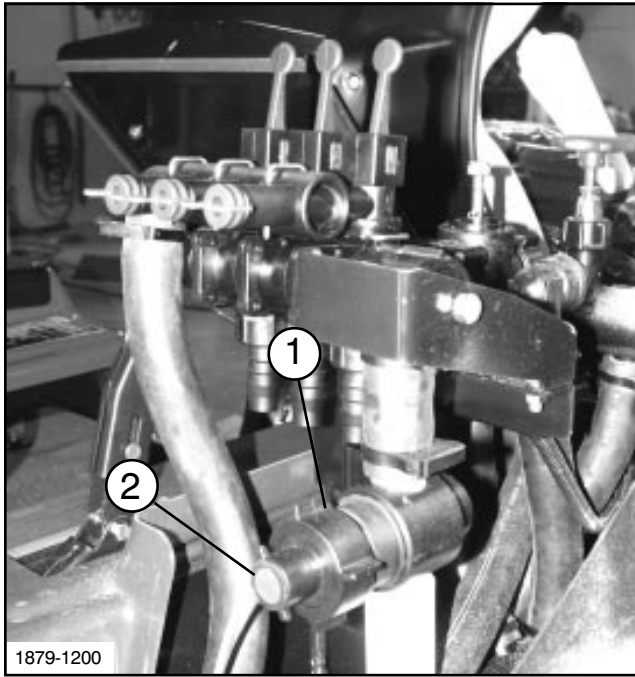

FIG. 7

- 1. Flowmeter
- 2. Indicator Light

FLOWMETER (SEE FIG. 7):

The Flowmeter may need to be disassembled for periodic cleaning or to remove an obstruction. Disconnect the signal wire and remove the retaining cap by unscrewing it from the body. Pull the Paddle Wheel assembly from the housing.

Once disassembled, use warm water and if necessary, a mild detergent and soft bristled brush to clean all parts. **DO NOT USE SOLVENTS OR DIESEL FUEL TO CLEAN THE FLOWMETER.** A magnet should work well for removing fine metallic particles from the turbine. Inspect all parts. Check for excessive bearing or shaft wear.

- Keep all electrical connections clean at all times.
- A protective coating may be applied to the completed electrical connections, if desired.

SPRAY PRO™ MONITOR:

Store the monitor in a cool dry location if it will not be used for an extended period of time, such as during the off-season.

BOOM CONTROL VALVE:

IMPORTANT: Before performing any maintenance, make sure line pressure is relieved.

INSPECT VALVE CONE AND O-RING'S:

See parts drawing (FIG. 8) for reference.

1. Flush the sprayer with clean water and open all Boom Control Valves. Shut sprayer engine off.
2. Remove fork and remove hose for the Boom Bypass valves. When the housing is drained make sure everything is clear from the hose.
3. Start the sprayer. There should not be any flow of liquid through the Boom Bypass passage. If there is any leakage, the valve O-Ring's must be changed. Shut sprayer engine off.

REPLACE VALVE O-RING'S:

1. Remove long fork and pull the valve assembly off the valve housing.
2. Remove screw from end of valve stem and pin from handle to replace the valve O-Ring's. There is one (1) at each end of the spool, one (1) on the bypass valve, two (2) on the valve body, and three (3) on the valve stem.
3. Reassemble in opposite sequence.
4. Retest, per inspection procedure.

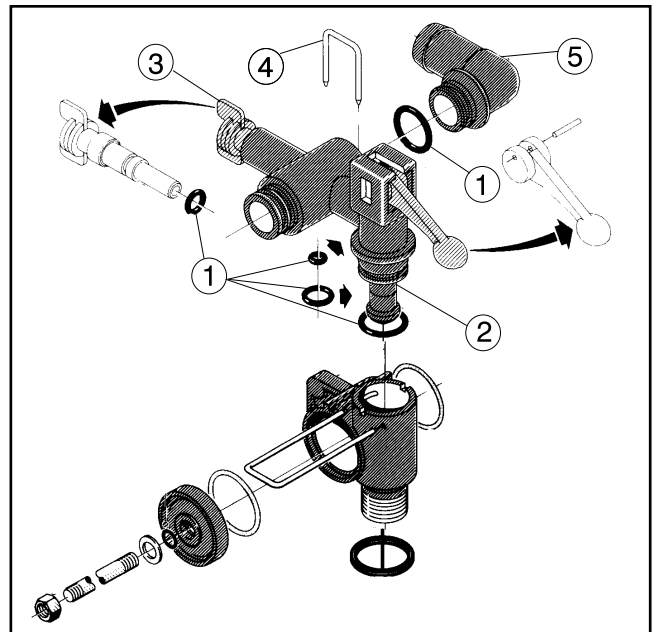
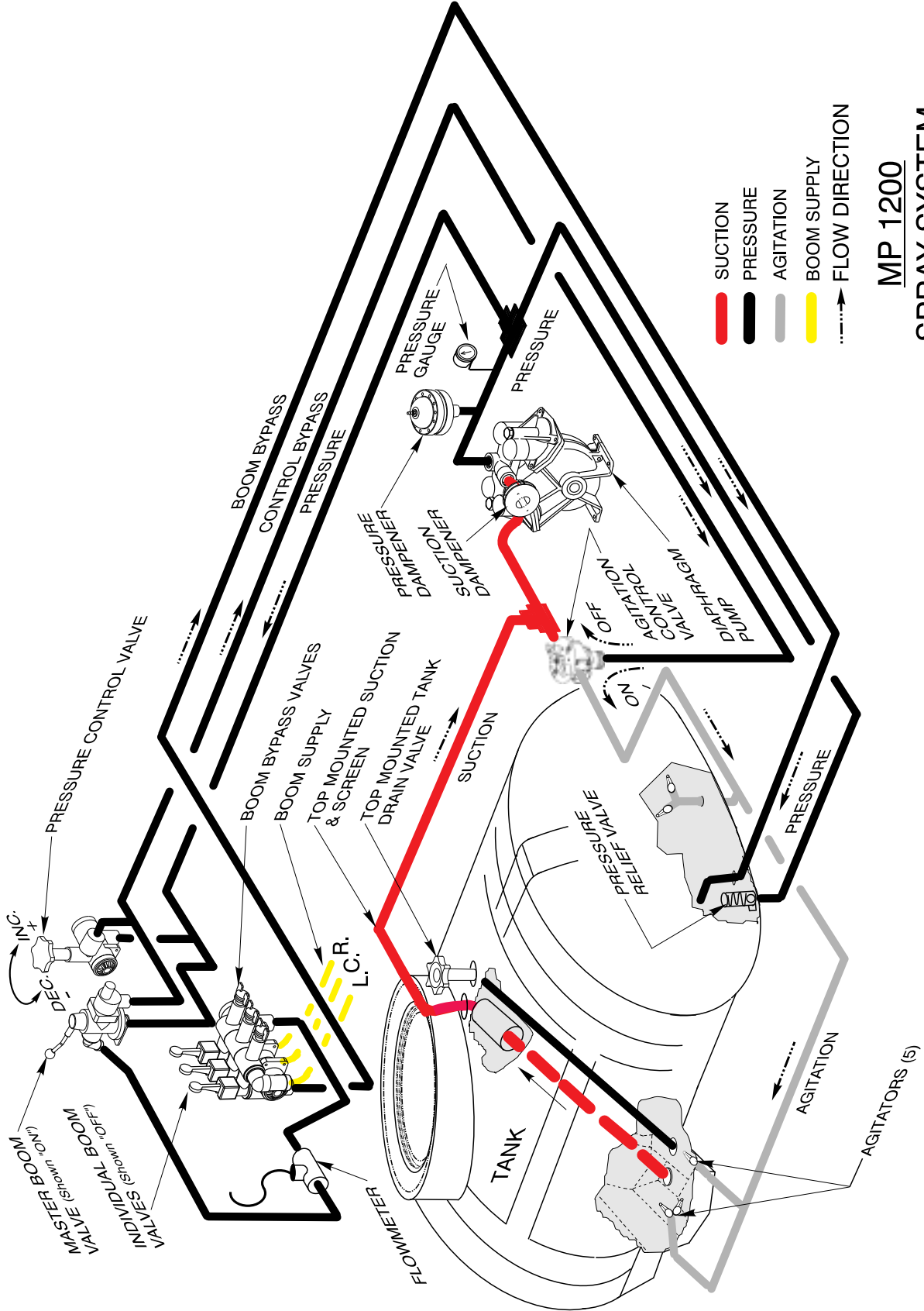
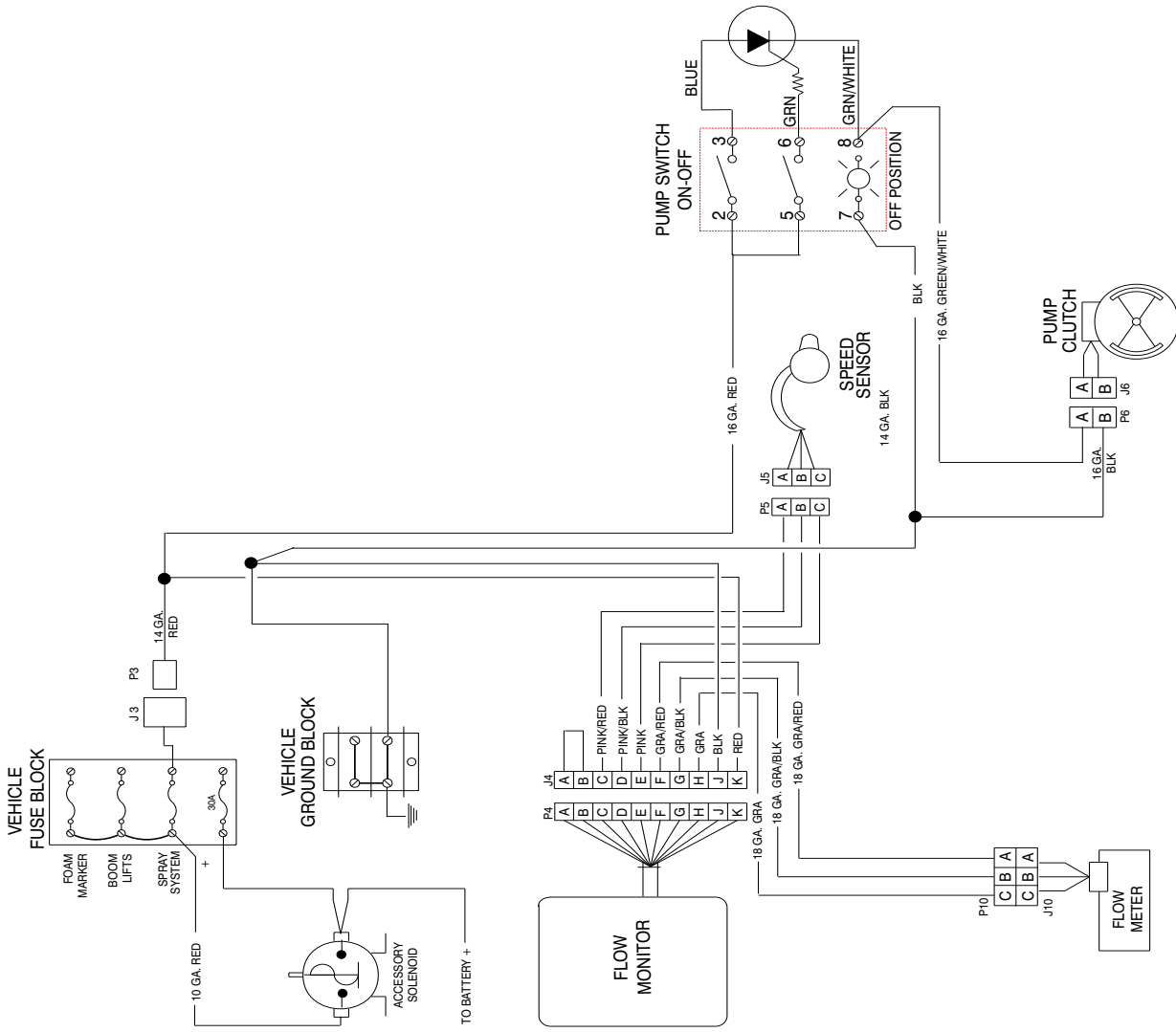

FIG. 8

- 1. O-Ring's
- 2. Distribution Valve ASM
- 3. Adjustment Knob
- 4. Boom Bypass Fork
- 5. Boom Bypass Hose Elbow

SPRAY SYSTEM FLOW DIAGRAM





SPRAY SYSTEM ELECTRICAL DIAGRAM

MAINTENANCE

TROUBLESHOOTING THE CONTROL VALVES

CONDITION	POSSIBLE CAUSES	REPAIR
<p>1. Individual Boom or Master Boom Valve won't open. Pressure control valve difficult to turn.</p>	<p>Debris in valve</p>	<ul style="list-style-type: none"> - Flush system with water and neutralizing agent. - Disassemble valve, clean thoroughly and replace O-Ring's and seals as necessary.
<p>2. Individual Boom Valve won't shut off.</p>	<p>Valve O-Ring's deteriorated</p>	<p>Pull fork under Individual Boom Valve. Inspect and make repairs as necessary.</p>
<p>3. Leakage around Master or Individual Boom Valves.</p>	<p>O-Ring deteriorated</p>	<p>Disassemble valve and replace O-Ring's.</p>
<p>4. Valve operating properly, but pressure drop too high.</p>	<p>Obstruction in valve body</p>	<p>Remove inlet and outlet connections and inspect body.</p>
<p>5. Master Boom Valve won't shut off.</p>	<p>Ball or seat in Master Valve defective.</p>	<p>Remove hose from front of valve and replace ball and seat.</p>

SPRAY PRO™ - TROUBLESHOOTING

All Spray Pro™ consoles are tested prior to packaging, so unless there has been damage in shipment you can be confident that everything will be operational when you receive it.

However, if you do encounter a problem that appears to be related to equipment failure, PLEASE DO NOT OPEN THE CONSOLE. Your system is protected by a warranty and TORO will correct any defect.

CONSOLE APPEARS DEAD:

Using a test light, check for 12 volts at the power source. Also check for damaged power cable. (Console requires 12 volts for proper operation).

SPEED IS ALWAYS ZERO OR ERRATIC:

Check for properly established SPEED CAL. The default "SPEED CAL" number is .91. Check cable for breaks or incomplete connection.

For more suggestions on solutions to speed problems, see "Checking Individual Components" section this page.

CALIBRATION DISTANCE COUNT IS INACCURATE:

SPEED CAL was incorrectly measured or entered. The default calibration is .91, review calibration, readjust and test.

NO READOUT OF APP. RATE OR CALIBRATION FLOW:

Check to see that the sprayer pump and equipment are operating properly. If liquid is moving through the flowmeter, check that the flowmeter diagnostic light is flashing. For details, see "Flowmeter Maintenance" section, page 68.

Check to see that a FLOWMETER CAL number has been entered. Also check cable for breaks or incomplete connection.

If the flowmeter has not been used for a long period of time, the rotor may be sticky. Flushing the system out with water should make the rotor spin freely.

Flow rate may be too low to register a reading, or foreign material may be lodged in the flowmeter.

CALIBRATION FLOW IS INACCURATE:

This may result from an incorrectly-entered "FLOWMETER CAL" value. The default "FLOW CAL" number is 919. This number should be fine tuned as described in the "Fine Tuning Flowmeter Calibration" section, see page 61-62. Other causes may be a flow rate too low to register, or foreign material lodged in the flowmeter.

6553.5 MESSAGE DISPLAYED IN THE RATE MODE:

If this message appears when you are in motion with the sprayer on, it indicates that speed sensor impulses have been lost.

CONSOLE IS ERRATIC IN OPERATION:

If you have a two-way radio, it may be mounted too close to the console. Keep all Spray Pro™ cables, antenna and power cable away from the radio.

DISPLAYED MEASUREMENTS DO NOT MAKE SENSE:

The console may be in the incorrect measurement mode (US or metric).

DISPLAY READS "OFL":

CALIBRATION DISTANCE and CALIBRATION FLOW will read OFL when they have exceeded their maximum count. Reset to zero to resume counting. All counters will read OFL if total width calibration is greater than 65535.

SPRAY PRO™ - TROUBLESHOOTING

CHECKING INDIVIDUAL COMPONENTS:

CONSOLE:

The only way to field test a monitor is to connect it to a harness on a vehicle with a known working console.

HARNESS:

The harness can be checked using an ohmmeter or continuity tester. The wiring diagram below (See FIG. 1) shows the pin out of all connectors. Simply check for continuity between connected pins and for no continuity between unconnected pins.

POWER:

The Spray Pro™ cable has a ten-pin connector labeled A-K. (See FIG. 1) Check between J-K with a volt meter or test light. If there is no power, trace cable toward battery looking for breaks. Also check fuses that supply power to the monitor.

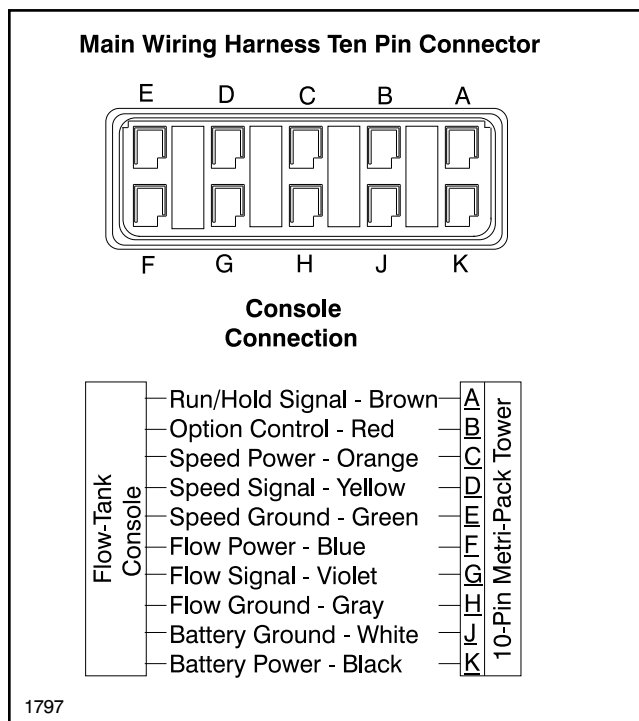

FIG. 1

1. Pinout Locations

SPEED SENSOR AND FLOWMETER POWER:

The Speed Sensor and Flowmeter both have a 12 volt power supply. Check for 12 volts between pins A and C in the connector at the sensors. If power is not present, make sure the sensor power wire is not open or shorted to ground or to another wire. If this wire has a problem, the console may exhibit erratic behavior or not function at all.

MAGNETIC HALL – EFFECT SPEED AND FLOW SENSORS:

Caution: Improper connection or voltage could damage the Hall-effect sensor.

SPEED SENSOR:

Remove sensor from transaxle. Ground pin C and connect clean 12 volts to pin A of the Speed Sensor connector. Connect the positive lead (red) of an ohmmeter or continuity tester to pin B and the negative lead (black) of the ohmmeter or continuity tester to pin C of the Speed Sensor connector.

Holding the tip for sensor in open air should result in a very high resistance (infinite), while holding the tip of the sensor to within 1/16" of steel material should result in a very low resistance (near zero).

SPEED INPUT:

Turn rotary switch to speed position and disconnect speed sensor from the main harness. Using a clip lead or other jumper wire (such as a paper clip bent in a "U"), several times rapidly short together pins B and C of the 3-pin connector (See FIG. 2). The console should respond with some speed reading.

FLOWMETER:

The Flowmeter has an indicating light on the top for diagnostics. As fluid flows through the meter, or if the Rotor is spun by hand, the light should flash with a frequency proportional to the speed of the Rotor. No light at all indicates no power to the meter. A steady light indicates a faulty meter.

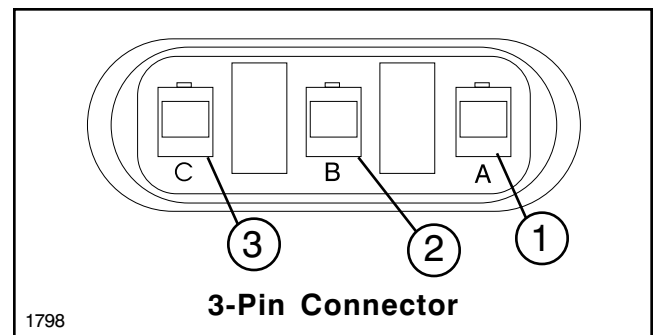

FIG. 2

1. Pin A- 12V Pos.

2. Pin B- Signal

3. Pin C- 12V Neg.

STORAGE

Check the machine thoroughly for any replacement parts required. In the event parts are needed, place your order with your TORO distributor in the fall or winter to avoid the delays caused by the usual spring rush. When ordering parts please specify the MODEL NUMBER and the SERIAL NUMBER of the MULTI PRO® 1200 Turf Sprayer.

TRACTION UNIT:

1. Thoroughly clean the traction unit and engine.
2. Check the tire pressure. Inflate all tires to 18-20 psi.
3. Check all fasteners for looseness; tighten as necessary.
4. Grease or oil all grease fittings and pivot points. Wipe up any excess lubricant.
5. Lightly sand and use touch up paint on painted areas that are scratched, chipped or rusted.
6. Service the battery and cables as follows:
 - A. Remove the battery terminals from the battery posts.
 - B. Clean the battery, terminals, and posts with a wire brush and baking soda solution.
 - C. Coat the cable terminals and battery posts with Grafo 112x skin-over grease (TORO Part No. 505-47) or petroleum jelly to prevent corrosion.
 - D. Slowly recharge the battery every 60 days for 24 hours to prevent lead sulfurizing of the battery.
 - E. Maintain Battery fluid level. (See page 44)

ENGINE:

1. Drain the crankcase completely, and refill with recommended engine oil (S.A.E. 10) or equivalent.
2. Run engine until completely out of gasoline, then restart and run on unleaded gasoline mixed with stabilizer for at least 10 minutes.
3. While the engine is still running and at completion of above run, treat upper cylinders by spraying one to two ounces of recommended engine oil into carburetor air intake for about 10 to 15 seconds. Open throttle for short bursts of speed, shut off ignition and allow engine to come to a stop while continuing to spray recommended engine oil into the air intake.

4. Disconnect and remove battery.
5. Clean exterior surface of engine.
6. Leave spark plugs in holes or seal spark plug holes with suitable threaded metal plugs.
7. Seal all openings in engine and accessories with weatherproof tape. Mask off all areas used for electrical contact.
8. Make sure all surfaces are dry, including ignition wiring, and all exterior surfaces of engine.
9. Thoroughly clean and service the air cleaner assembly.
10. Seal the air cleaner inlet, the exhaust outlet, and the crankcase breather with weatherproof tape.
11. Check the oil filler cap and gas cap to ensure they are all securely in place.

SPRAYING SYSTEM:

1. Flush pump and entire spraying system with water and tank cleaning agent. Drain pump and spray system completely.
2. Add a rust inhibiting biodegradable antifreeze solution to the pump and recirculate through the system, coating the pump interior. Drain solution completely.
3. Check condition of spray hoses. Tighten all hose connections securely.
4. Lubricate boom pivot grease fittings and pivot points.

CAUTION

If the vehicle is stored in proximity to flames or sparks, explosive fumes may accumulate and ignite; causing injury or death.

- **Never store a vehicle with gasoline in the tank.**
- **Never store a vehicle where fumes may reach an open flame or spark.**
- **Allow engine to cool before storing in any enclosure.**

PERFORMANCE VERIFICATION

Refer to the preceding information in this manual for complete and detailed instructions.
Follow all Safety Instructions.

Gallons Per Acre:

Determine Desired Application Rate From Manufacturers Labeling _____ G.P.A.

Determine a Vehicle Application Speed _____ M.P.H.

Verify Nozzle Spacing is 20".

Determine Gallons Per Minute _____ G.P.M. (See **Nozzle Chart on Page 52 & 53**) and Use The Following Formula to verify.

$$\frac{\text{G.P.A.} \times \text{M.P.H.} \times 20''}{5940}$$

$$\frac{\text{_____} \times \text{_____} \times 20}{5940} = \frac{\text{_____}}{5940} = \text{_____ G.P.M.}$$

Select Nozzle Size (See **Nozzle Chart on Page 52 & 53**) _____ based on G.P.M.

Determine Application Pressure _____ psi (See **Nozzle Chart on Page 52 & 53**).

Gallons Per 1,000 sq. ft.:

Determine Desired Application Rate From Manufacturers Labeling _____ G.P. 1,000sq. ft.

Determine a Vehicle Application Speed _____ M.P.H.

Verify Nozzle Spacing is 20"

Determine Gallons Per Minute _____ G.P.M. (See **Nozzle Chart on Page 52 & 53**) and Use The Following Formula to verify

$$\frac{\text{G.P. 1,000 sq. ft.} \times \text{M.P.H.} \times 20''}{136}$$

$$\frac{\text{_____} \times \text{_____} \times 20}{136} = \frac{\text{_____}}{136} = \text{_____ G.P.M.}$$

Select Nozzle Size (See **Nozzle Chart on Page 52 & 53**) _____ based on G.P.M.

Determine Application Pressure _____ psi (See **Nozzle Chart on Page 52 & 53**)

SETUP SPRAY SYSTEM

Fine tune Flowmeter

Set Parking Brake.

Fill tank ½ full with water **DO NOT** add Chemical at this time.

Install Correct Nozzles.

Turn Pump ON/OFF Switch on.

Turn Master Boom Valve on.

Turn Individual Boom Valves on.

Set engine speed and lock in position.

Program test speed in Spray Pro™.

Set App. Rate to _____ GPA.

Visually Inspect The Output Of All Nozzles.

Turn Booms and Pump Off.

Perform Rate Check.

RATE CHECK

Verify G.P.A. application rate via **1/128th Acre Method**

Mark off a test course in a flat area at 204 feet.

Drive the Sprayer with a ½ full tank of water at selected **application speed** and record the time it takes to drive 204 feet. _____ seconds. **NOTE: It is important to maintain your application speed during test.**

Rate Check (Cont'd)

Park Vehicle. **SET PARKING BRAKE.**

Turn on pump and all booms and maintain _____ GPA with Test Speed (predetermined).

Hold a graduated cylinder under the far left nozzle on the left boom. Collect the output for the same amount of time that it took to travel 204 ft.

Each ounce of fluid collected equals a 1 gallon per acre application rate.

Repeat collection test twice for each nozzle record amount collected each test below.

Proceed through each column separately and completely.

Each Nozzle Should Be Within ± 5% Of The Average Of All Nozzles

Replace Each Nozzle Not ± 5% Of The GPA Average Range

Replace All Nozzles If Two or More Are Not Within The ± 5% GPA Range

#1		oz/GPA
#2		oz/GPA
#3		oz/GPA
#4		oz/GPA
#5		oz/GPA
#6		oz/GPA
#7		oz/GPA
#8		oz/GPA
#9		oz/GPA
#10		oz/GPA
#11		oz/GPA
Total		
	÷ 11	
Average 1		GPA

#1		oz/GPA
#2		oz/GPA
#3		oz/GPA
#4		oz/GPA
#5		oz/GPA
#6		oz/GPA
#7		oz/GPA
#8		oz/GPA
#9		oz/GPA
#10		oz/GPA
#11		oz/GPA
Total		
	÷ 11	
Average 1		GPA

Both Averages Should Be Within 5% Of Each Other

CALCULATE RANGE

Gallons Per Acre:

$$\text{Average 1} \quad \underline{\hspace{1cm}} \quad \times \quad .95 = \boxed{\hspace{1cm}} = -5\%$$

$$\text{Average 1} \quad \underline{\hspace{1cm}} \quad \times \quad 1.05 = \boxed{\hspace{1cm}} = +5\%$$

(GPA Range)

Your GPA Application Rate must fall within the GPA Range

Gallons Per 1,000 sq. ft.

$$\text{Average 1} \quad \underline{\hspace{1cm}} \quad \times \quad .95 = \boxed{\hspace{1cm}} \div 43.56 = \boxed{\hspace{1cm}} = -5\% \text{ G.P. 1,000 sq. ft.}$$

$$\text{Average 1} \quad \underline{\hspace{1cm}} \quad \times \quad 1.05 = \boxed{\hspace{1cm}} \div 43.56 = \boxed{\hspace{1cm}} = +5\% \text{ G.P. 1,000 sq. ft.}$$

(GPA Range)

(GP 1,000 sq. ft. Range)

Your GP 1,000 sq. ft. Application Rate must fall within the GP 1,000 sq. ft. Range

NOTES:

NOTES:

NOTES:

The Toro General Commercial Products Warranty

A Two-Year Limited Warranty

Conditions and Products Covered

The Toro Company and its affiliate, Toro Warranty Company, pursuant to an agreement between them, jointly warrant your 1996 or newer Toro Commercial Product ("Product") purchased after January 1, 1997, to be free from defects in materials or workmanship for two years or 1500 operational hours*, whichever occurs first. Where a warrantable condition exists, we will repair the Product at no cost to you including diagnosis, labor, parts, and transportation. This warranty begins on the date the Product is delivered to the original retail purchaser.

* Product equipped with hour meter

Instructions for Obtaining Warranty Service

You are responsible for notifying the Commercial Products Distributor or Authorized Commercial Products Dealer from whom you purchased the Product as soon as you believe a warrantable condition exists.

Toro Commercial Products Service Department
Toro Warranty Company
8111 Lyndale Avenue South
Bloomington, MN 55420-1196
612-888-8801
800-982-2740
E-mail: commercial.service@toro.com

Owner Responsibilities

As the Product owner, you are responsible for required maintenance and adjustments stated in your operator's manual. Failure to perform required maintenance and adjustments can be grounds for disallowing a warranty claim

Items and Conditions Not Covered

Not all product failures or malfunctions that occur during the warranty period are defects in materials or workmanship. This express warranty does not cover:

- Product failures which result from the use of non-Toro replacement parts, or from installation and use of add-on, modified, or unapproved accessories.
- Product failures which result from failure to perform required maintenance and/or adjustments.
- Product failures which result from operating the Product in an abusive, negligent or reckless manner.
- Parts subject to consumption through use unless found to be defective. Examples of parts which are consumer, or used up, during normal Product operation include, but are not limited to, blades, reels, bedknives, tines, spark plugs, castor wheels, tires, filters, belts, etc.

- Failures caused by outside influence, items considered to be outside influence include, but are not limited to, weather storage practices, contamination, use of unapproved coolants, lubricants, additives, or chemicals, etc.

- Normal "wear and tear" items. Normal "wear and tear" includes, but is not limited to, damage to seats due to wear or abrasion, worn painted surfaces, scratched decals or windows, etc.

Parts

Parts scheduled for replacement as required maintenance are warranted for the period of time up to the scheduled replacement time for that part.

Parts replaced under this warranty become the property of Toro. Toro will make the final decision whether to repair any existing part or assembly or replace it. Toro may use factory remanufactured parts rather than new parts for some warranty repairs.

General Conditions

Repair by an Authorized Toro Distributor or Dealer is your sole remedy under this warranty.

Neither The Toro Company nor Toro Warranty Company is liable for indirect, incidental or consequential damages in connection with the use of the Toro Products covered by this warranty, including any cost or expense of providing substitute equipment or service during reasonable periods of malfunction or non-use pending completion of repairs under this warranty. Except for the Emissions warranty referenced below, if applicable, there is no other express warranty. All implied warranties of merchantability and fitness for use are limited to the duration of this express warranty.

Some states do not allow exclusions of incidental or consequential damages, or limitations on how long an implied warranty lasts, so the above, exclusions and limitations may not apply to you.

This warranty gives you specific legal rights, and you may also have other rights which vary from state to state.

Note regarding engine warranty: The Emissions Control System on your Product may be covered by a separate warranty meeting requirements established by the U. S. Environmental Protection Agency (EPA) and/or the California Air Resources Board (CARB). The hour limitations set forth above do not apply to the Emissions Control System Warranty. Refer to the Engine Emission Control Warranty Statement printed in your operator's manual or contained in the engine manufacturer's documentation for details.

Countries Other than the United States or Canada

Customers who have purchased Toro products exported from the United States or Canada should contact their Toro Distributor (Dealer) to obtain guarantee policies for your country, province, or state. If for any reason you are dissatisfied with your Distributor's service or have difficulty obtaining guarantee information, contact the Toro importer. If all other remedies fail, you may contact us at Toro Warranty Company.