



Count on it.

Parts Catalog

**TimeCutter® 50in
Riding Mower**

Model No. 77501—Serial No. 40000000 and Up



Ordering Replacement Parts

To order replacement parts, please supply the part number, the quantity, and the description of each part desired.

Understanding Reference Numbers

Each identified part in an illustration has a reference number. The reference number for a part also appears in the parts list, along with other information about the part.

This catalog uses two special reference number formats, one to indicate parts in a service assembly and another to indicate the quantity of a given part in an illustration.

Service Assembly Reference Numbers

Parts in service assemblies have reference numbers in the form a:b. The a represents the reference number of the entire service assembly and the b represents a sequential number unique to each part within the service assembly.

For example, a wheel assembly might be identified by reference number 6, the tire by 6:1, the valve by 6:2, and the wheel by 6:3. When you order the assembly identified by reference number 6, you receive all parts identified by reference numbers 6:1, 6:2, and 6:3. However, you may also order any part individually. Reference numbers of this type appear in illustration and in parts lists.

Reference Numbers Indicating Quantity

In an illustration, if a reference number indicates more than one part, the reference number has the form nX y. The n represents the quantity of the part, the X is the multiplication symbol, and the y represents the reference number.

For example, in an illustration, the reference number 2X 37 means that two of the parts identified by reference number 37 are indicated.

Contents

Frame Assembly	4
Decklift Assembly	6
Caster Wheel Assembly	8
Traction Drive Assembly	10
LH Transaxle Assembly No. 139-7470	12
RH Transaxle Assembly No. 139-7471	14
Brake Assembly	16
Tire Assembly	18
Seat Pan Assembly	20
Motion Control Assembly	22
Engine and Muffler Assembly	24
Fuel Pod Assembly	26
Electrical Assembly	28
50in Deck and Decal Assembly	30
Frame Decal Assembly	32
Clutch Assembly	34
Attachments and Accessories	36

Frame Assembly

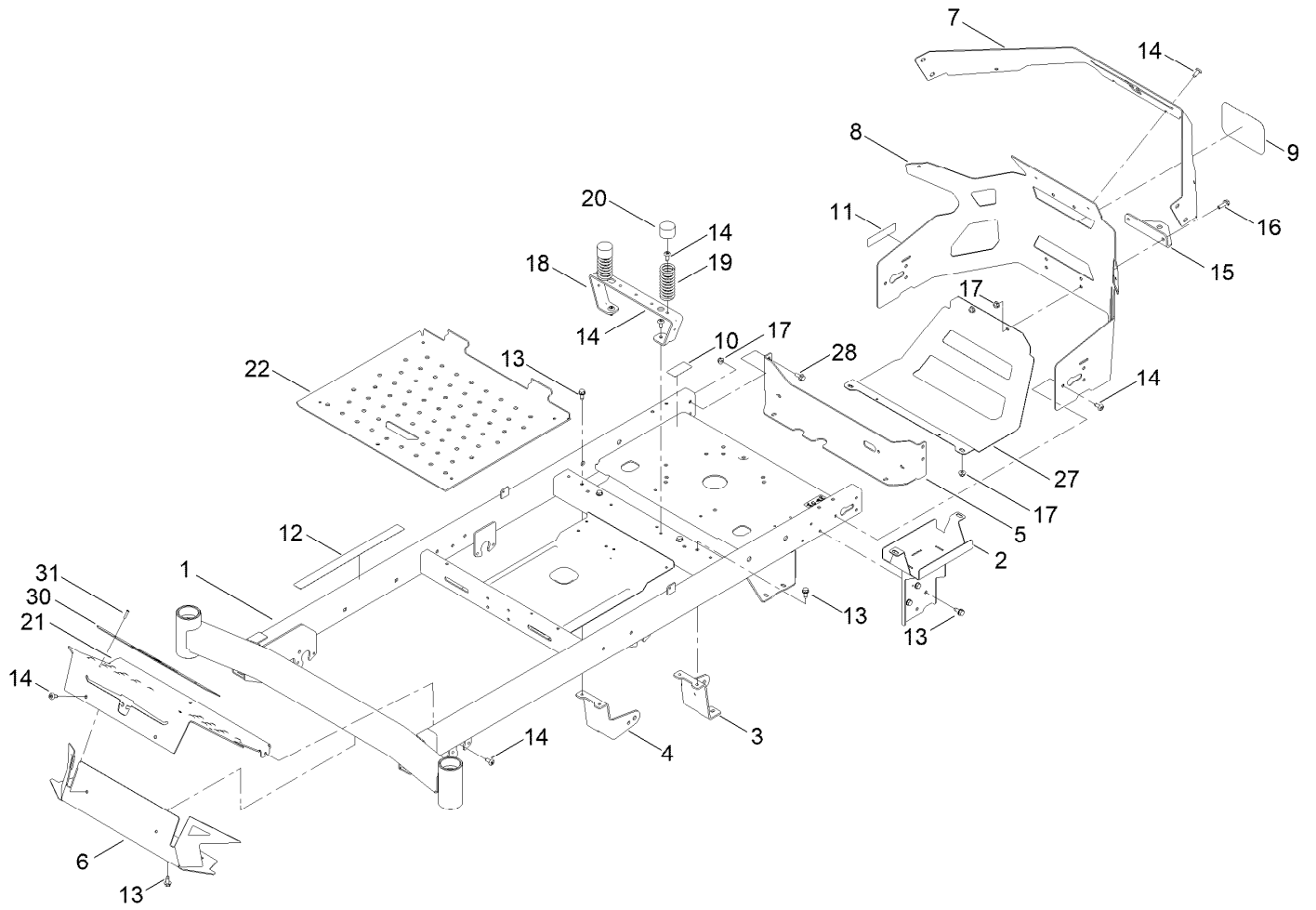

Frame Assembly (continued)

<i>Ref.</i>	<i>Part Number</i>	<i>Qty.</i>	<i>Description</i>	<i>Ref.</i>	<i>Part Number</i>	<i>Qty.</i>	<i>Description</i>
1	147-8723	1	Service ASM-Frame, Tc	14	138-9753	18	Screw
2	145-6283-01	1	Wa-Battery Mount	15	117-1232-03	1	Bracket-Hitch
3	145-6306-01	1	Mount-Drive, LH	16	139-2596	2	Screw-HHF
4	145-6307-01	1	Mount-Drive, RH	17	119-4041	8	Nut-HF
5	147-8709-03	1	Plate-Mount	18	145-6315-03	1	Support-Seat
6	147-2966-03	1	Footrest-Top	19	138-2548	2	Spring-Compression
7	147-2995-01	1	Plate-Rear Cladding Tc	20	701178	2	Cap-Protector
8	147-2994-03	1	Guard-Engine Tc	21	145-6368-01	1	Plate-Kick
9	99-4693	1	Decal	22	145-6370-01	1	Pan-Floor
10	161-6207	2	Decal-Bypass	27	147-7717-03	1	Guard-Muffler [black]
11	142-5864	1	Decal-Spark Arrester	28	139-2598	4	Screw-HHF
12	144-5288	1	Decal-Warning	30	147-8716-05	1	Plate- Toeboard
13	32144-70	9	Screw-HWHTF	31	130-8451	2	Rivet-Trifold

Decklift Assembly

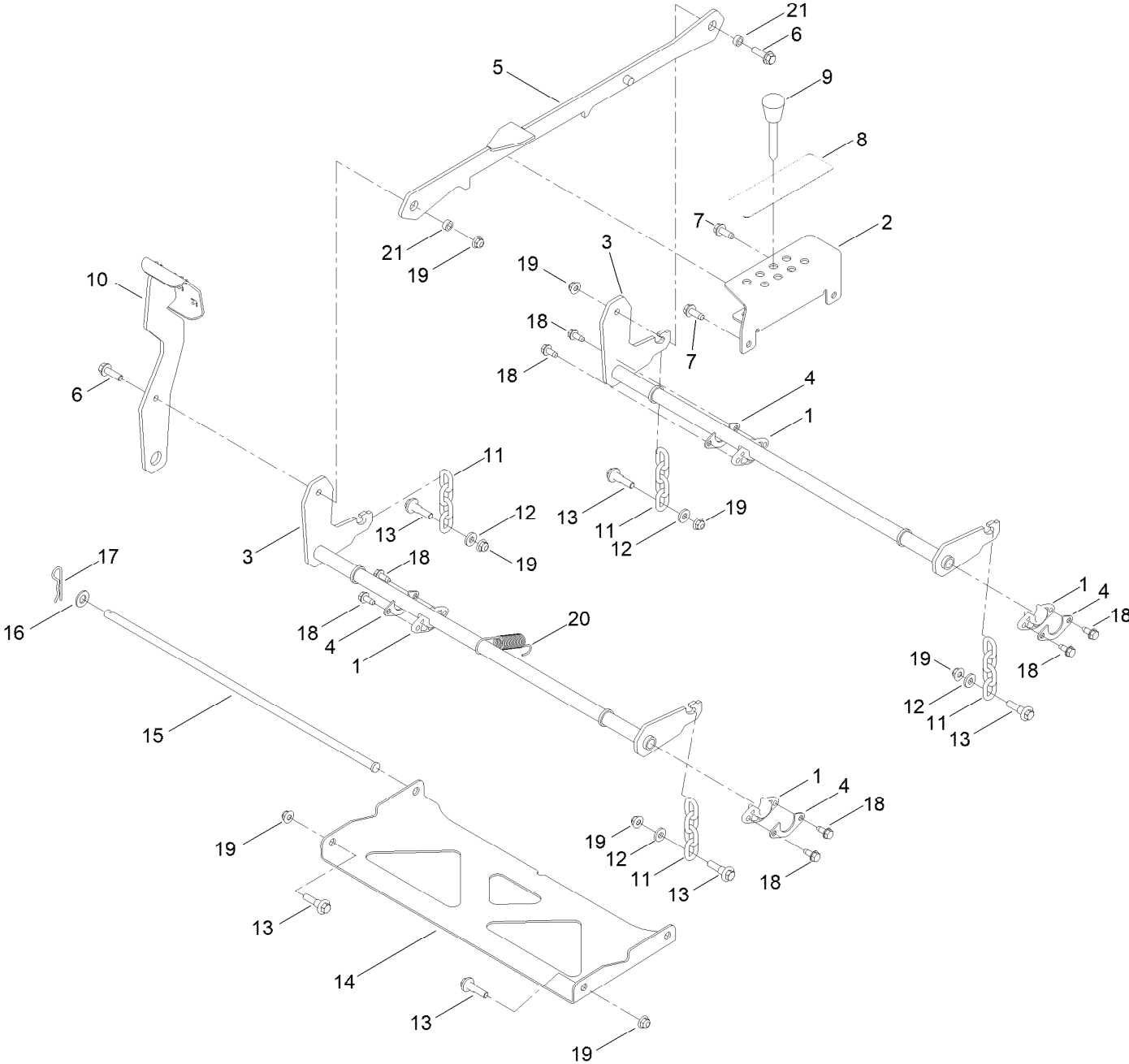

Decklift Assembly (continued)

<i>Ref.</i>	<i>Part Number</i>	<i>Qty.</i>	<i>Description</i>	<i>Ref.</i>	<i>Part Number</i>	<i>Qty.</i>	<i>Description</i>
1	139-5872	4	Bearing-Flange	12	138-7207	4	Spacer-Hub, Blower
2	145-6257-01	1	Bracket-HOC	13	130-0742	6	Bolt-Shoulder
3	145-4645-01	2	Pivot ASM-Decklift [red]	14	145-6248-03	1	Pan-Deck Pivot
4	138-7204	4	Gusset-Deck Lift	15	145-6288	1	Pin-Deck
5	145-0557-01	1	Link ASM-HOC [red]	16	139-2611	1	Washer-Flat
6	119-4061	2	Screw-HHF	17	139-2562	1	Pin-Hair
7	139-2428	2	Screw-HWH	18	32144-70	8	Screw-HWHTF
8	147-2866	1	Decal-HOC, Tc	19	119-4042	8	Nut-HF, NI
9	140-2146	1	HOC Pin ASM	20	138-7206	1	Spring-Extension
10	145-6278-01	1	Pedal ASM [red]	21	140-2093	2	Spacer
11	138-7205	4	Chain-Decklift, 4-Link				

Caster Wheel Assembly

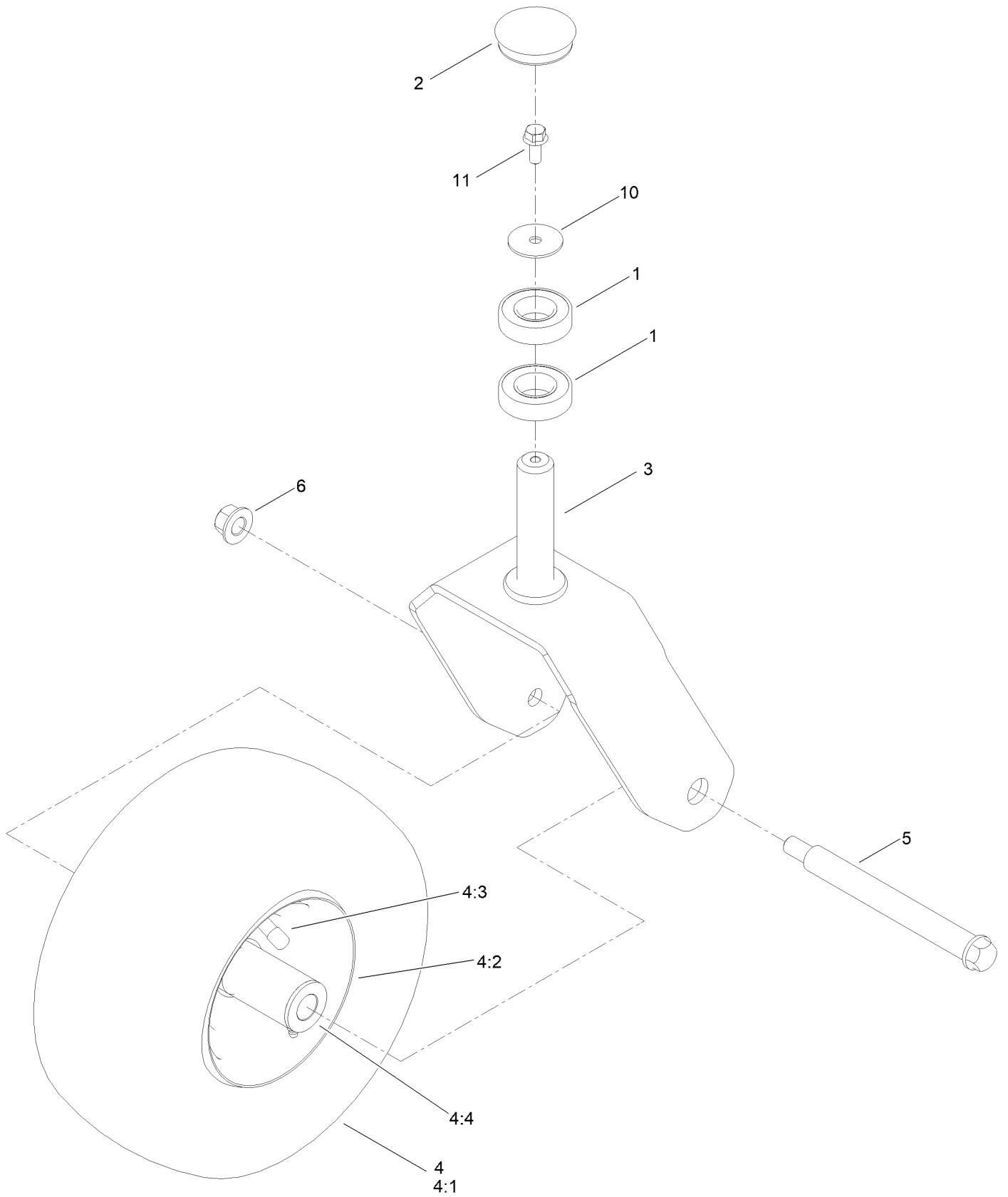

Caster Wheel Assembly (continued)

<i>Ref.</i>	<i>Part Number</i>	<i>Qty.</i>	<i>Description</i>	<i>Ref.</i>	<i>Part Number</i>	<i>Qty.</i>	<i>Description</i>
1	109-3678	4	Bearing-Ball	4:3	232-27	1	Stem-Valve
2	144-0375	2	Cap, Grease	4:4	114-1640	2	Bushing-Flange
3	145-4674-01	2	Fork	5	145-4649	2	Screw-Shoulder HHF
4	145-4692	2	Wheel ASM - Caster 12X6-5	6	99-5107	2	Nut-Lock
4:1	145-4672	1	Tire 12X6-5	10	115-1151	2	Washer-Flat
4:2	145-4673	1	Wheel (W/ Zerk And Bushings)	11	100-1668	2	Screw-HHF

Traction Drive Assembly

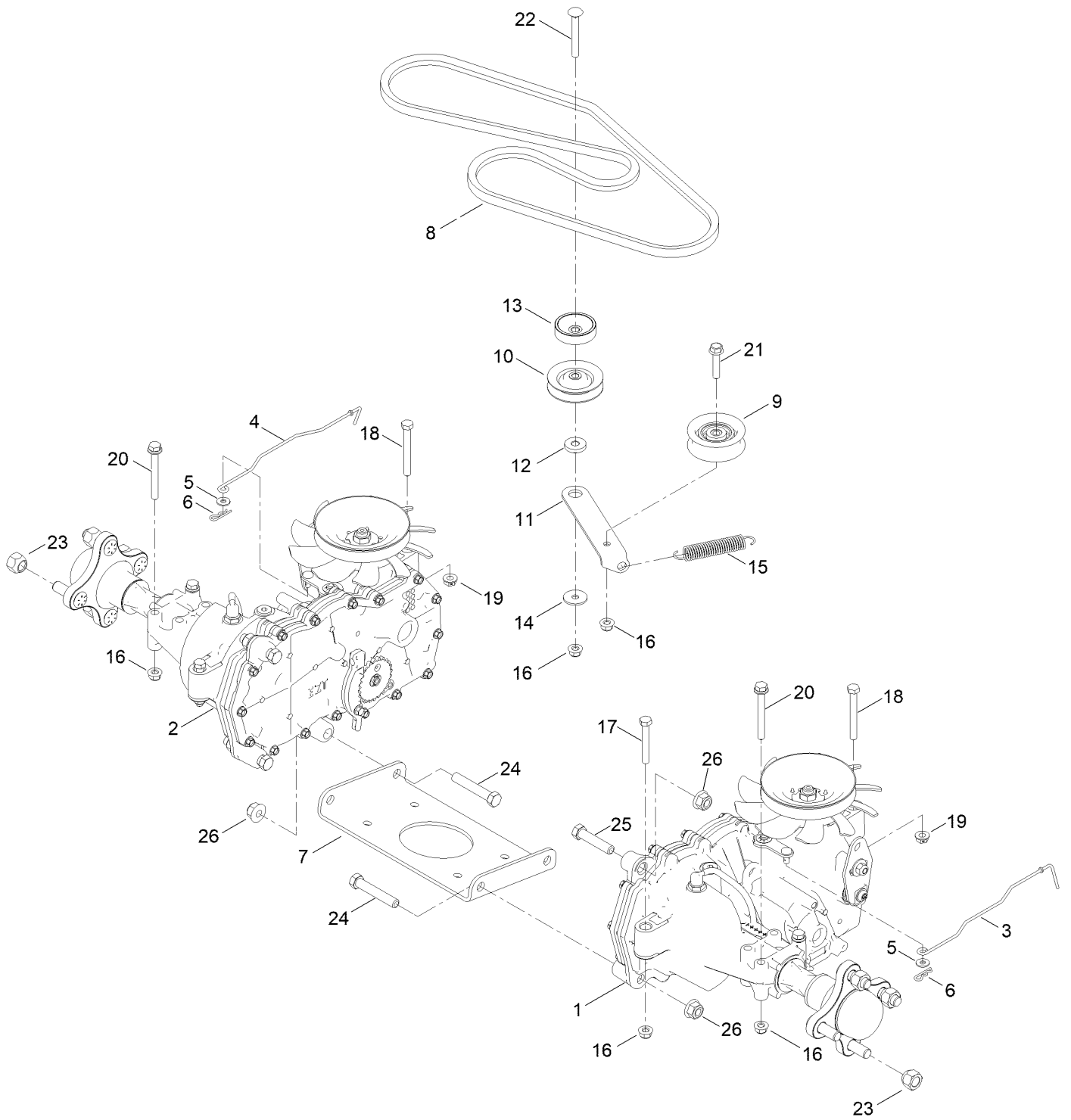

Traction Drive Assembly (continued)

<i>Ref.</i>	<i>Part Number</i>	<i>Qty.</i>	<i>Description</i>	<i>Ref.</i>	<i>Part Number</i>	<i>Qty.</i>	<i>Description</i>
1	139-7470	1	LH Hydro Transaxle ASM	14	5-4460	1	Washer-Pivot
2	139-7471	1	RH Hydro Transaxle ASM	15	137-7040	1	Spring-Return, Pedal
3	147-2988	1	Rod-Bypass, LH	16	104-8300	8	Nut-HF, NI
4	147-2989	1	Rod-Bypass, RH	17	322-11	2	Screw-HH
5	119-8952	2	Washer-Spcl	18	145-6388	2	Screw-HH Spcl
6	3290-307	2	Pin-Cotter	19	139-2574	2	Nut-HF
7	145-6390-03	1	Plate-Cross Hydro	20	138-7590	4	Screw-HHF
8	145-6361	1	V-Belt (A Sec 63.8 EI)	21	115-1794	1	Screw-HHF
9	138-7597	1	Pulley-Idler, Flat	22	3230-8	1	Screw-CARR
10	68-0030	1	Idler	23	242-50	8	Nut-Lug
11	147-2925	1	Arm-Idler	24	324-10	4	Screw-HH
12	138-7277	1	Spacer-Arm, Idler	25	324-8	2	Screw-HH
13	138-9809	1	Spacer	26	114-8417	6	Nut-HF, NI

LH Transaxle Assembly No. 139-7470

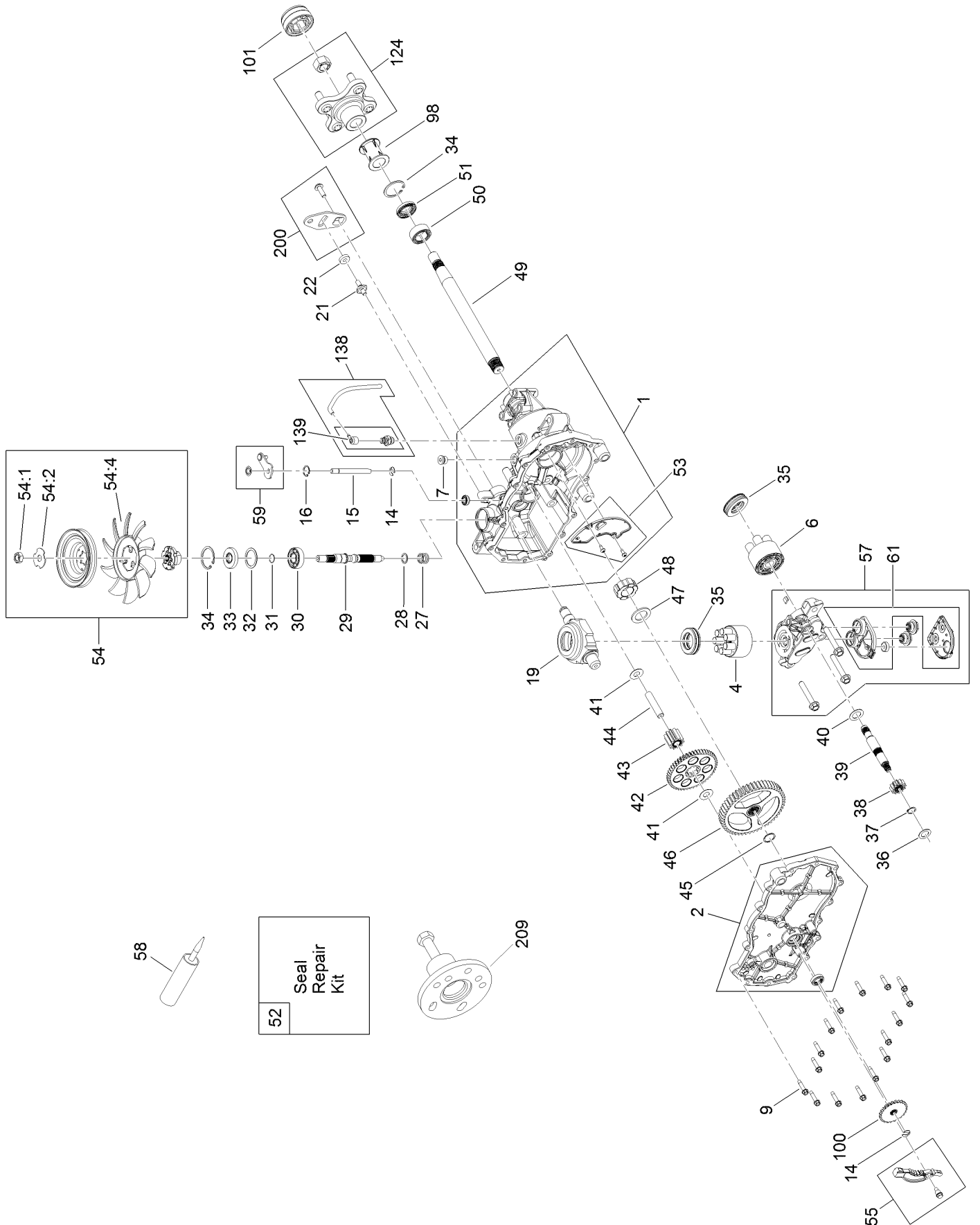

LH Transaxle Assembly No. 139-7470 (continued)

<i>Ref.</i>	<i>Part Number</i>	<i>Qty.</i>	<i>Description</i>	<i>Ref.</i>	<i>Part Number</i>	<i>Qty.</i>	<i>Description</i>
1	106-8695	1	Main Housing ASM	41	94-1933	2	Washer
2	106-8696	1	Side ASM	42	132-0911	1	Gear-49T
4	110-8561	1	Pump Block ASM	43	104-5318	1	Gear-Jackshaft, 10T
6	103-2666	1	Cylinder Block Kit	44	104-5329	1	Pin-Jackshaft
7	104-2189	1	Plug-Thread, Straight	45	112-9854	1	Ring-Spiral, Retaining
9	117-5359	16	Screw-HHF	46	112-9855	1	Gear-52T, Bull
14	106-8677	2	Ring-Retaining, External	47	112-9856	1	Washer
15	106-8678	1	Rod-Bypass	48	112-9857	1	Bearing-Sleeve
16	106-8679	1	Ring-Retaining, Internal	49	120-7104	1	Shaft-Axle
19	104-5304	1	Swashplate-Trunnion	50	112-9859	1	Bushing-Axle
21	104-2116	1	Stud	51	112-9860	1	Seal-Lip
22	112-9853	1	Puck-Friction	52	106-8686	1	Seal Kit
27	94-1936	1	Spring-Block	53	106-8697	1	Expansion Plate Kit
28	94-1937	1	Washer-Thrust	54	135-7349	1	Fan And Pulley Kit
29	104-5306	1	Shaft-Input	55	106-8688	1	Brake Arm Kit
30	104-5311	1	Bearing-Ball	57	112-9861	1	Center Section Filter Kit
31	104-5307	1	Ring-Retaining	59	120-5549	1	Bypass Kit
32	104-5308	1	Spacer	61	114-1634	1	Filter Kit
33	104-5310	1	Seal-Lip	98	120-7109	1	Tube-Axle
34	104-5309	2	Ring-Retaining	100	106-8694	1	Disc-Brake, Cog
35	94-6922	2	Bearing-Thrust	101	115-5057	1	Cover-Nut, Axle
36	104-5339	1	Washer-Flat	124	109-5939	1	Hub Kit
37	104-5340	1	Ring-Retaining	138	112-9866	1	Breather Kit
38	132-0912	1	Gear-12T	139	114-1635	1	Breather ASM
39	106-8683	1	Shaft-Motor	200	117-5362	1	Control Arm Kit
40	104-5360	1	Washer	209	114-8467	1	Puller-Hub, 4 Bolt

RH Transaxle Assembly No. 139-7471 (continued)

<i>Ref.</i>	<i>Part Number</i>	<i>Qty.</i>	<i>Description</i>	<i>Ref.</i>	<i>Part Number</i>	<i>Qty.</i>	<i>Description</i>
1	106-8674	1	Main Housing ASM	41	94-1933	2	Washer
2	106-8675	1	Side ASM	42	132-0911	1	Gear-49T
4	110-8561	1	Pump Block ASM	43	104-5318	1	Gear-Jackshaft, 10T
6	103-2666	1	Cylinder Block Kit	44	104-5329	1	Pin-Jackshaft
7	104-2189	1	Plug-Thread, Straight	45	112-9854	1	Ring-Spiral, Retaining
9	117-5359	16	Screw-HHF	46	112-9855	1	Gear-52T, Bull
14	106-8677	2	Ring-Retaining, External	47	112-9856	1	Washer
15	106-8678	1	Rod-Bypass	48	112-9857	1	Bearing-Sleeve
16	106-8679	1	Ring-Retaining, Internal	49	120-7104	1	Shaft-Axle
19	104-5304	1	Swashplate-Trunnion	50	112-9859	1	Bushing-Axle
21	104-2116	1	Stud	51	112-9860	1	Seal-Lip
22	112-9853	1	Puck-Friction	52	106-8686	1	Seal Kit
27	94-1936	1	Spring-Block	53	106-8687	1	Expansion Plate Kit
28	94-1937	1	Washer-Thrust	54	135-7349	1	Fan And Pulley Kit
29	104-5306	1	Shaft-Input	55	106-8688	1	Brake Arm Kit
30	104-5311	1	Bearing-Ball	57	112-9862	1	Center Section Filter Kit
31	104-5307	1	Ring-Retaining	59	107-2489	1	Bypass Arm Kit
32	104-5308	1	Spacer	61	114-1634	1	Filter Kit
33	104-5310	1	Seal-Lip	98	120-7109	1	Tube-Axle
34	104-5309	2	Ring-Retaining	100	106-8694	1	Disc-Brake, Cog
35	94-6922	2	Bearing-Thrust	101	115-5057	1	Cover-Nut, Axle
36	104-5339	1	Washer-Flat	124	109-5939	1	Hub Kit
37	104-5340	1	Ring-Retaining	138	112-9866	1	Breather Kit
38	132-0912	1	Gear-12T	139	114-1635	1	Breather ASM
39	106-8683	1	Shaft-Motor	200	117-5362	1	Control Arm Kit
40	104-5360	1	Washer	209	114-8467	1	Puller-Hub, 4 Bolt

Brake Assembly

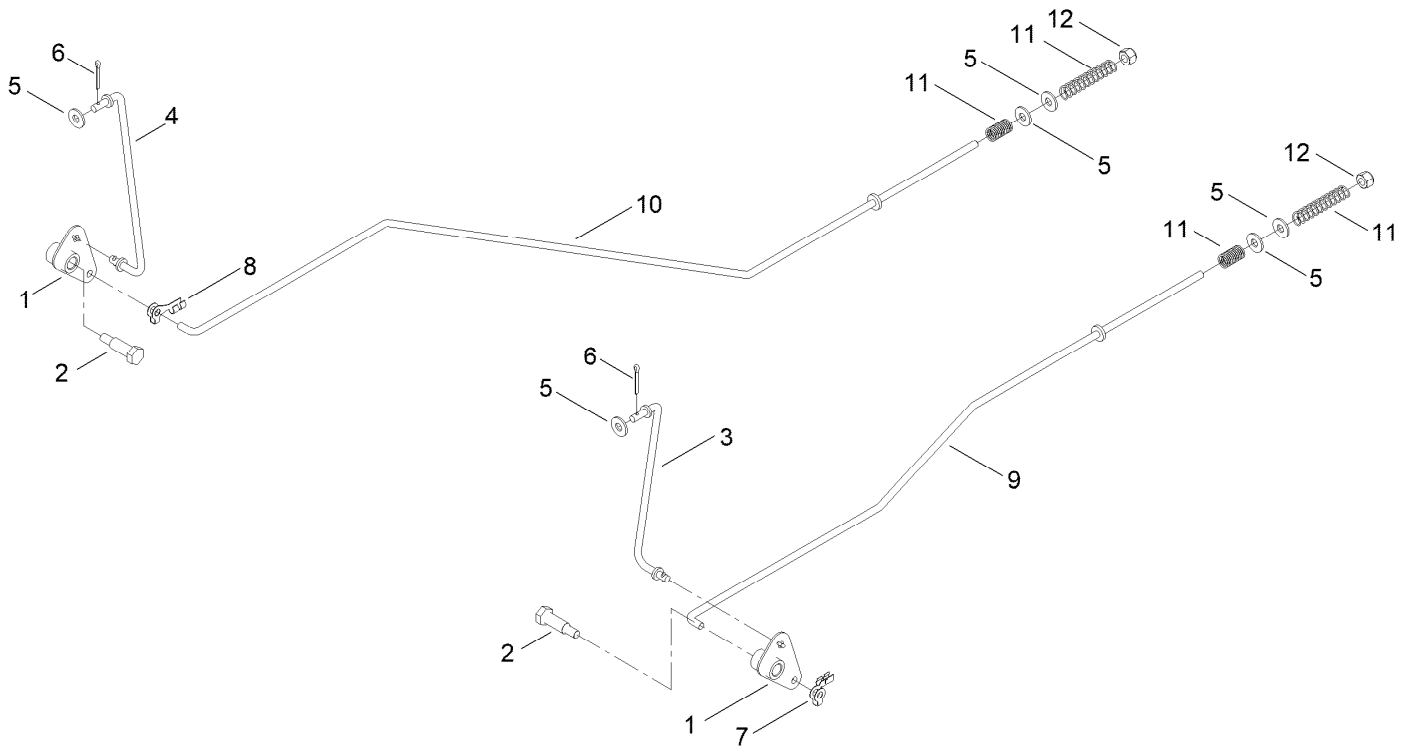

Brake Assembly (continued)

<i>Ref.</i>	<i>Part Number</i>	<i>Qty.</i>	<i>Description</i>	<i>Ref.</i>	<i>Part Number</i>	<i>Qty.</i>	<i>Description</i>
1	144-1858	2	Bellcrank	7	144-1816	1	Clip-Rod, LH (7L, 1/4In)
2	145-6364	2	Bolt-Shoulder	8	144-1815	1	Clip-Rod, RH (7R, 1/4In)
3	145-4607	1	Link-Brake, LH	9	144-1860	1	Rod-Brake, LH
4	145-6238	1	Link-Brake, RH	10	144-1851	1	Rod-Brake, RH
5	119-8952	6	Washer-Spcl	11	117-1169	4	Spring-Compression
6	120-9716	2	Pin-Cotter	12	3296-42	2	Nut-Lock, NI

Tire Assembly

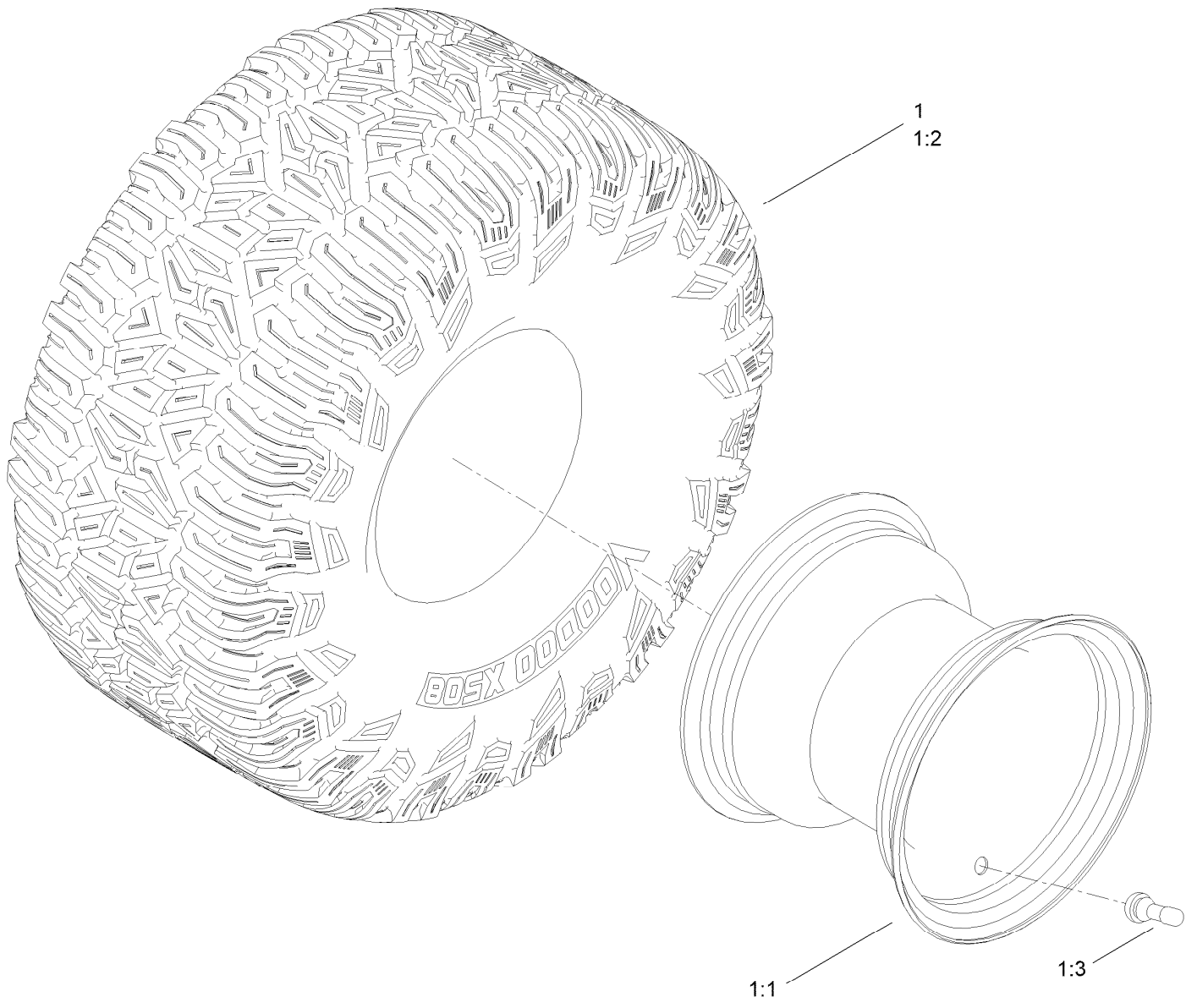

Tire Assembly (continued)

<i>Ref.</i>	<i>Part Number</i>	<i>Qty.</i>	<i>Description</i>	<i>Ref.</i>	<i>Part Number</i>	<i>Qty.</i>	<i>Description</i>
1	145-6391	2	Tire ASM	1:2	147-5179	1	Tire
1:1	147-5180	1	Rim	1:3	232-27	1	Stem-Valve

Seat Pan Assembly

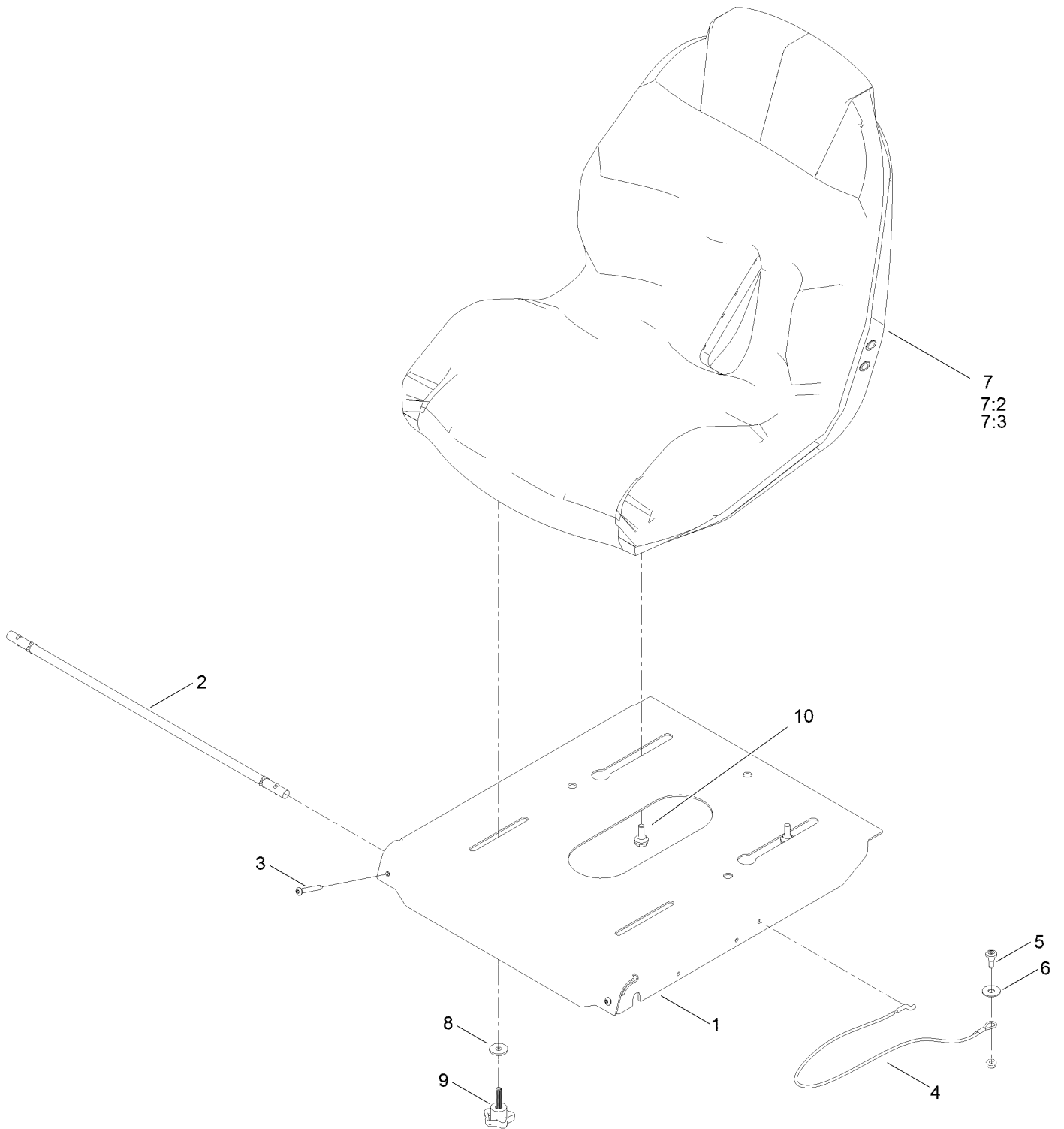

Seat Pan Assembly (continued)

<i>Ref.</i>	<i>Part Number</i>	<i>Qty.</i>	<i>Description</i>	<i>Ref.</i>	<i>Part Number</i>	<i>Qty.</i>	<i>Description</i>
1	147-3002-03	1	Pan-Seat	7	147-8732	1	Seat ASM - Seat King Sk130
2	147-5169	1	Rod-Pivot	7:2	147-8752	1	Cover-Seat
3	147-5175	2	Screw-Tbh,Thd Roll	7:3	82-2190	1	Switch-Bail
4	161-4452	1	Cable-Lanyard, 26.75In	8	1-603716	2	Washer-Friction
5	135-2015	1	Screw-Shoulder	9	139-2401	2	Knob
6	147-5287	1	Washer-Flat	10	147-5174	2	Bolt-Shoulder,Hfh

Motion Control Assembly

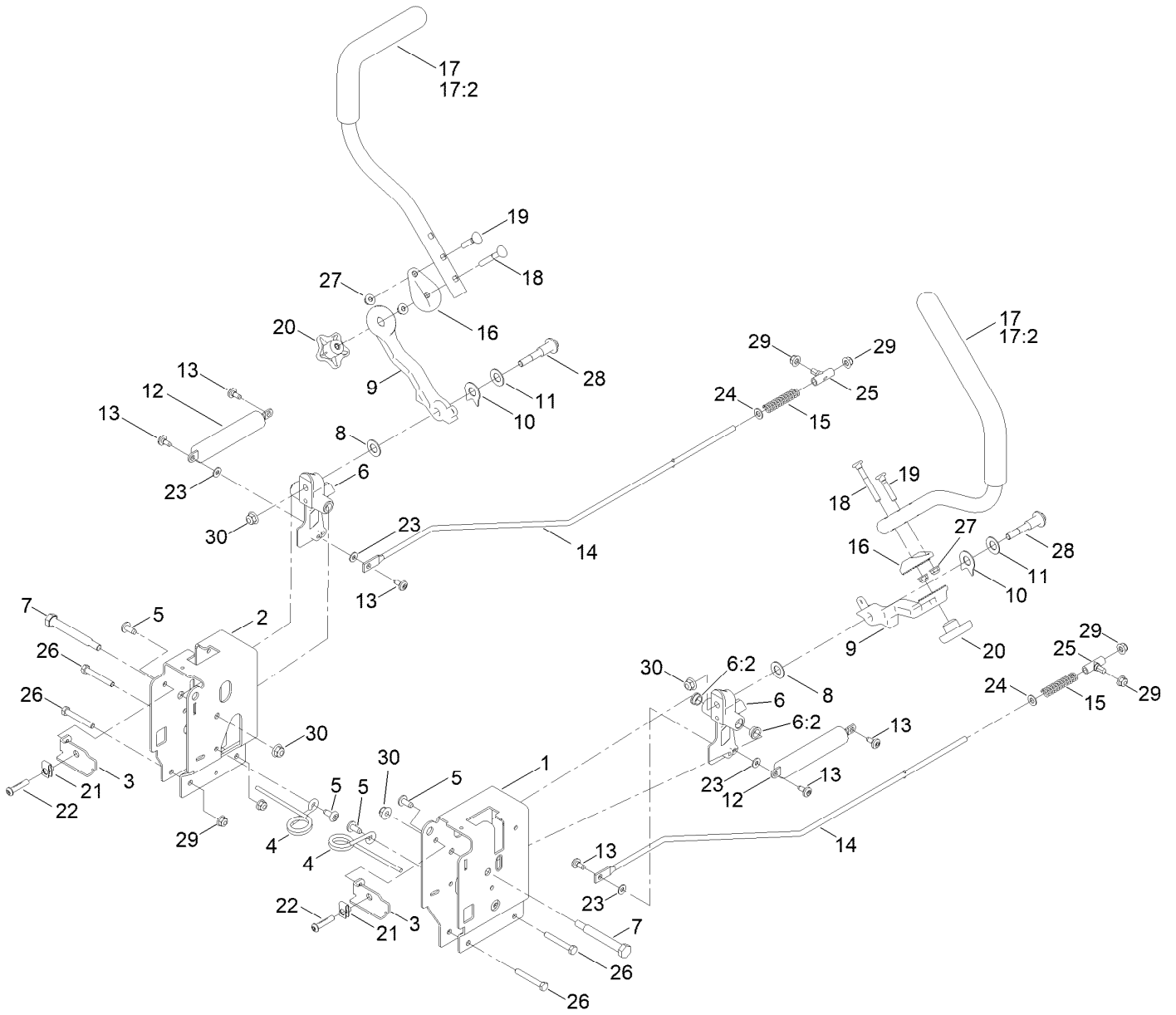

Motion Control Assembly (continued)

<i>Ref.</i>	<i>Part Number</i>	<i>Qty.</i>	<i>Description</i>	<i>Ref.</i>	<i>Part Number</i>	<i>Qty.</i>	<i>Description</i>
1	145-4615-03	1	Control Box - LH G7	16	147-5192-05	2	Disc-Adjustment Handle, 32 Teeth
2	145-4647-03	1	Control Box - RH G7	17	145-6327	2	Handle-Control,
3	147-7580-03	2	Adjustment Plate-Control Box	17:2	147-3029	1	Grip
4	145-6253	2	Spring-Torsion	18	145-6366	2	Screw-Handle
5	138-9753	4	Screw	19	137-3008	2	Screw-Handle
6	145-4648	2	Pivot Arm ASM	20	117-5976	2	Knob-Handle
6:2	256-156	2	Bushing-Flange	21	112-3306	2	Nut
7	115-5099	2	Bolt-Pivot	22	126-4299	2	Screw-HSBH
8	120-2273	2	Washer-Nylon	23	119-8952	4	Washer-Spcl
9	147-5191-05	2	Arm-Control, 32 Teeth	24	120-9683	2	Washer-Plain
10	142-8478	2	Spacer, Anti-Rotation	25	138-7218	2	Mount-Rod, Hydro
11	119-8925	2	Washer-Belleville	26	120-9738	4	Screw-HH
12	132-6853	2	Damper-Non Cavitating	27	138-8401	4	Nut-HF
13	120-7950	6	Screw-Torx	28	117-1198	2	Bolt-Pivot
14	145-4699	2	Rod - Hydro, LH	29	104-8300	8	Nut-HF, NI
15	138-7252	2	Spring-Compression	30	104-8301	4	Nut-HF, NI

Engine and Muffler Assembly

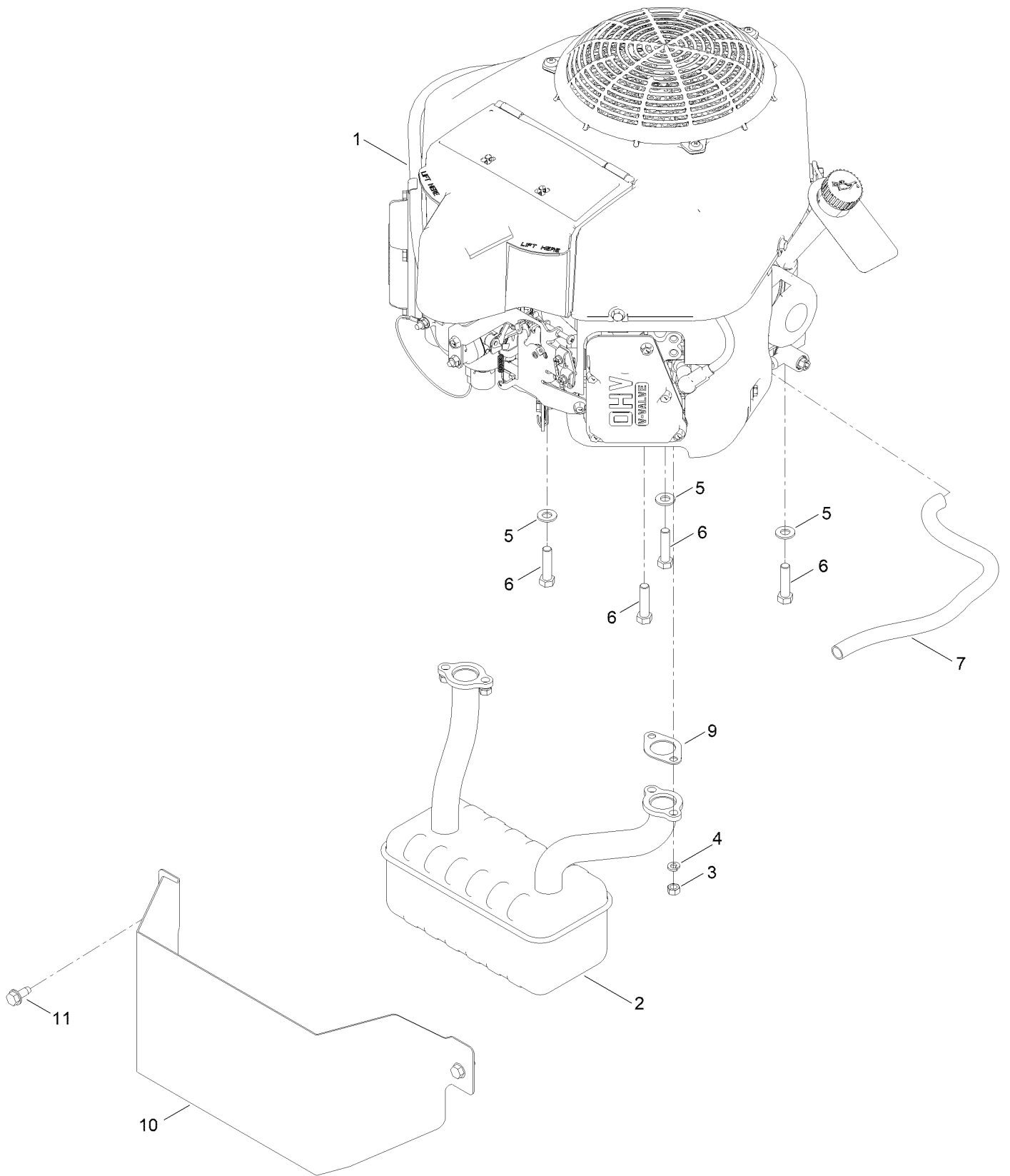

Engine and Muffler Assembly (continued)

<i>Ref.</i>	<i>Part Number</i>	<i>Qty.</i>	<i>Description</i>	<i>Ref.</i>	<i>Part Number</i>	<i>Qty.</i>	<i>Description</i>
1		1	Engine-Kawasaki, Fr691V-_s07-R ●■	6	323-50	4	Bolt-HH
2	139-5867	1	Muffler	7	106-7022	1	Tube-Drain, Oil
3	114-3549	4	Nut	9	1-653313	2	Gasket-Exhaust
4	114-3550	4	Washer-Lock	10	161-6221-03	1	Heat Shield-Muffler
5	3256-24	3	Washer-Plain	11	32144-70	2	Screw-HWHTF

● Not serviced separately

■ Obtain parts from www.kawpower.com

Fuel Pod Assembly (continued)

<i>Ref.</i>	<i>Part Number</i>	<i>Qty.</i>	<i>Description</i>	<i>Ref.</i>	<i>Part Number</i>	<i>Qty.</i>	<i>Description</i>
1	145-6304	1	Fuel Tank ASM	20	2412-80	1	Clamp-Hose
1:2	46-6560	2	Bushing	21	2412-98	2	Clamp-Hose
1:3	144-5302	1	Fitting-Elbow 90	22	147-2975-03	1	Mount-Pod Bracket RH
1:4	147-2934	1	Fitting-Pickup, Fuel	23	147-5170-03	1	Plate-Kick
2	147-7657	1	Neck-Filler, Fuel	24	147-2977-03	1	Mount-Pod Bracket RH
3	137-4119	1	Cap-Fuel, Ratcheting	25	147-8742	1	Pod ASM - RH W/Decals
4	145-4698	1	Hose-Filler, Fuel	25:2	139-2394	1	Decal-Control Lever, RH
5	2412-130	2	Clamp-Hose	27	107069	1	Clip
6	147-2973-01	1	Cast-Tube, RH [red]	28	147-2990-03	1	Panel-Control
7	147-2972-01	1	Cast-Tube, LH [red]	29	147-8753	1	Decal - Control Panel W/Out Hour Meter
8	147-2974-03	1	Mount-Pod Bracket LH	30	32105-15	1	Screw-HWH
9	120-7950	10	Screw-Torx	32	140-4956	1	Hose-Fuel
10	32144-70	6	Screw-HWHTF	33	109-0275	1	Hose-Fuel
11	147-8741	1	Pod ASM - LH W/Decals	34	32180-030	1	Clip-Tie
11:2	139-2395	1	Decal-Control Lever, LH	35	144-1983	1	Adapter Orifice
11:3	147-2399	1	Decal-Fuel Fill	36	108-6344	1	Hose-Fuel
12	32144-41	4	Screw-Taptite	37	614249	2	Tie-Cable
14	147-5176	1	Rod-Hold Down	38	139-2403	1	Cable-Throttle
15	32144-4	2	Screw-HWH	39	139-2402	1	Cable-Choke
16	147-2978	1	Fender-Time Cutter, LH	43	147-7712	1	Ring-Retaining
17	147-2979	1	Fender-Time Cutter, RH	45	161-4609-03	1	Bracket-Alignment, Pod LH
18	147-2976-03	1	Bracket-Rear Pod, LH	46	161-4610-03	1	Bracket-Alignment, Pod RH
19	138-9753	4	Screw				

Electrical Assembly

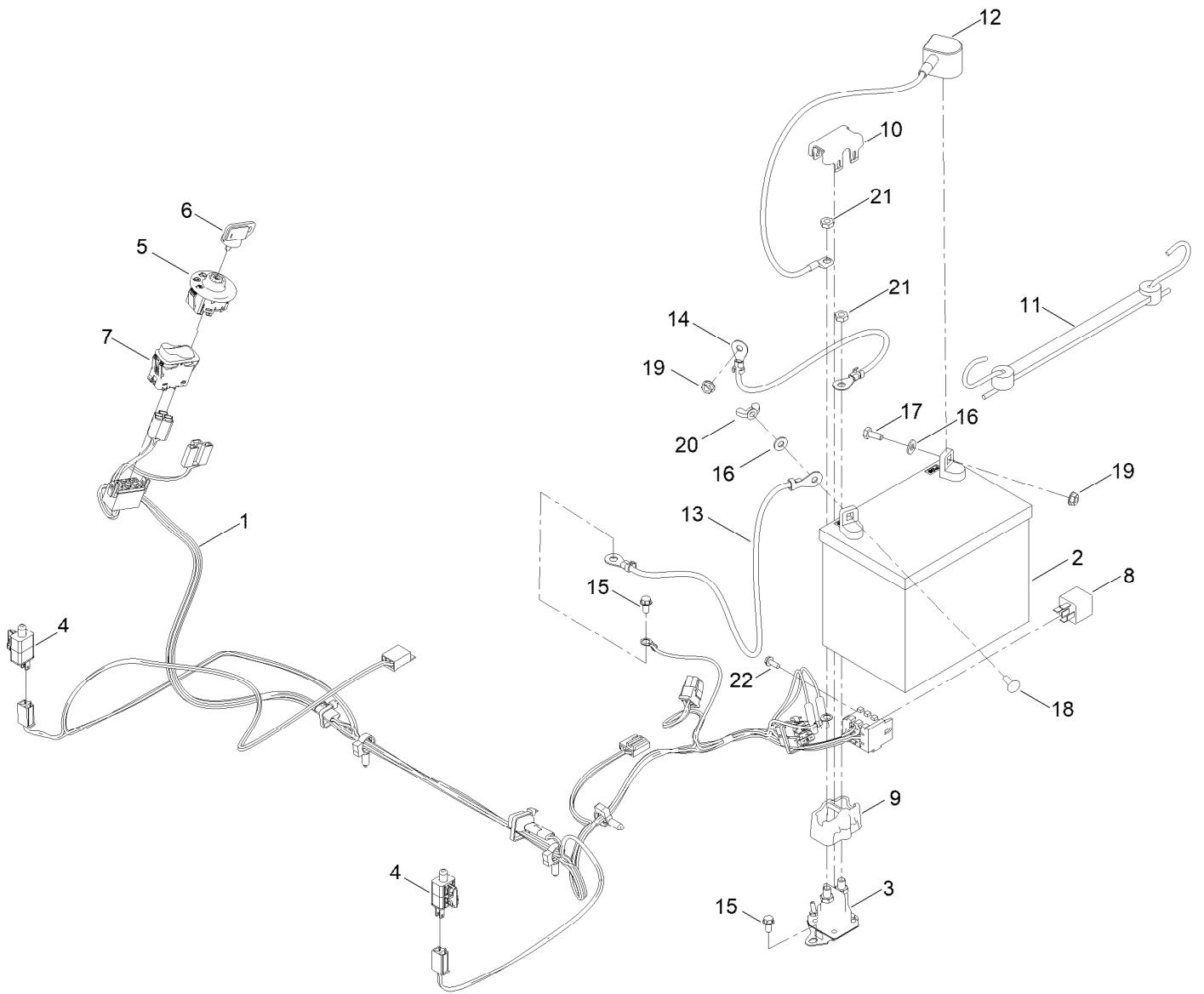

Electrical Assembly (continued)

<i>Ref.</i>	<i>Part Number</i>	<i>Qty.</i>	<i>Description</i>	<i>Ref.</i>	<i>Part Number</i>	<i>Qty.</i>	<i>Description</i>
1	145-6382	1	Harness-Wire, Main	12	147-2941	1	Cable-Battery,Red
2	140-2076	1	Battery - Wet	13	119-8899	1	Cable-Battery, Black
3	117-1197	1	Solenoid	14	121-0711	1	Cable-Battery, Positive
4	110-6765	2	Switch	15	32144-4	2	Screw-HWH
5	137-4100	1	Switch-Ignition	16	3256-22	2	Washer-Flat
6	63-8360	1	Key-Ignition	17	321-3	1	Screw-HH
7	139-6368	1	Switch-Rocker, On-None-On	18	3229-1	1	Screw-CARR
8	1-643275	1	Relay	19	32128-33	2	Nut-HF
9	140-2080	1	Cover-Solenoid	20	32103-22	1	Nut-Wing
10	140-2081	1	Cap-Solenoid	21	3220-2	2	Nut-Jam
11	104-2466	1	Holddown-Battery	22	139-1713	1	Screw-Thd Roll

50in Deck and Decal Assembly

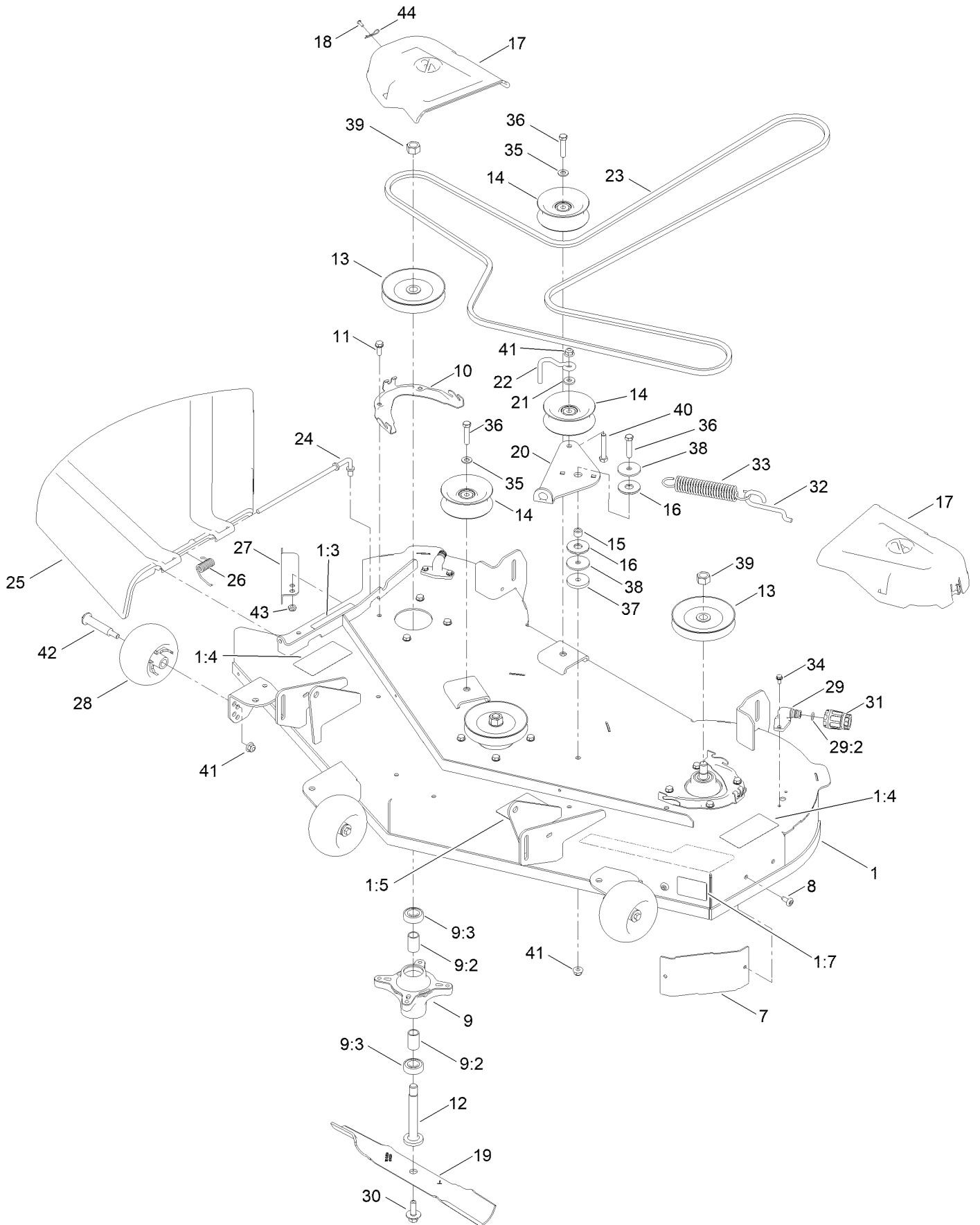

50in Deck and Decal Assembly (continued)

<i>Ref.</i>	<i>Part Number</i>	<i>Qty.</i>	<i>Description</i>	<i>Ref.</i>	<i>Part Number</i>	<i>Qty.</i>	<i>Description</i>
1	147-8745	1	50 In Deck & Decal ASM	23	147-2909	1	V Belt (A Sec 142.06 EI)
1:3	130-0731	1	Decal-Danger	24	137-2019	1	Rod-Pivot
1:4	132-0872	2	Decal-Danger, Deck	25	138-7502	1	Deflector-Discharge
1:5	99-3943	1	Decal-Routing, Belt	26	138-7268	1	Spring-Torsion
1:7	112-9840	1	Decal-Scalp, Anti	27	138-9800-03	1	Baffle-Cutoff
7	139-2448-03	1	Baffle-Corner	28	1-603299	3	Roller-Scalp, Anti
8	138-9753	2	Screw	29	133-9289	2	Fitting-Washout
9	139-3214	3	Spindle ASM	29:2	133-9290	1	O-Ring
9:2	120-7935	2	Spacer	30	145-0411	3	Bolt-Blade, Sems
9:3	138-9770	2	Bearing-Ball	31	95-3270	1	Connector-Hose
10	139-3272-03	2	Bracket-Cover, Belt	32	138-7266	1	Spring-Return, Hook
11	32144-41	12	Screw-Taptite	33	138-7264	1	Spring-Extension
12	117-7268	3	Shaft-Spindle	34	32144-4	4	Screw-HWH
13	139-7454	3	Pulley	35	3256-24	2	Washer-Plain
14	132-9420	3	Pulley-Idler, Flat	36	323-9	3	Screw-HH
15	115-4986	1	Spacer	37	110-9981	1	Washer-Plain
16	114-0463	2	Washer-Friction, Composite	38	63-7400	2	Washer-Rebound
17	144-1906	2	Cover-Belt	39	3219-6	3	Nut-Hex
18	94-6961	2	Screw	40	323-11	1	Screw-HH
19	115-5059-03	3	Blade-Hi Lift	41	104-8301	5	Nut-HF, NI
20	138-7262	1	Arm-Idler	42	112-3977	3	Bolt-Shoulder
21	138-7207	1	Spacer-Hub, Blower	43	3296-59	1	Nut-Lock, NI
22	138-7270	1	Guide-Belt, Idler	44	144-1944	2	Pin-Hair

Frame Decal Assembly

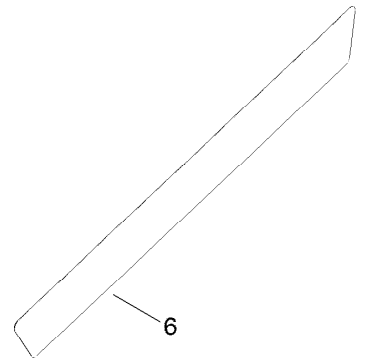
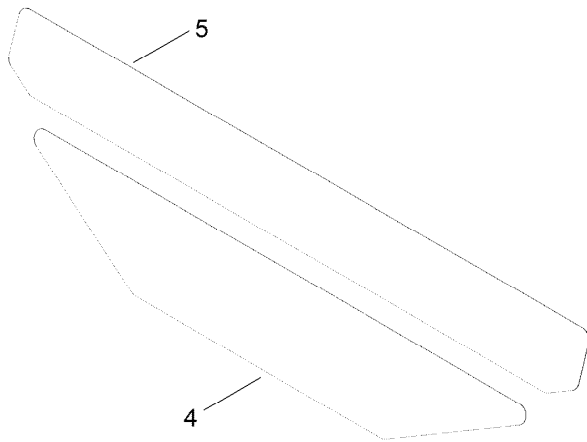
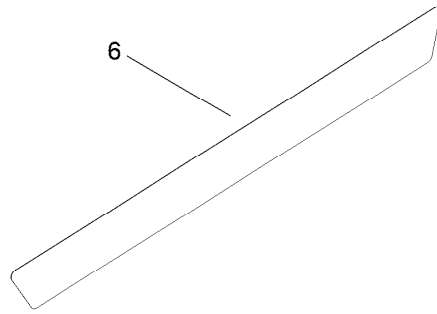

Frame Decal Assembly (continued)

<i>Ref.</i>	<i>Part Number</i>	<i>Qty.</i>	<i>Description</i>
4	147-7573	1	Decal-Max
5	147-7561	1	Decal-Timecutter
6	147-7560	2	Decal-Timecutter

Clutch Assembly

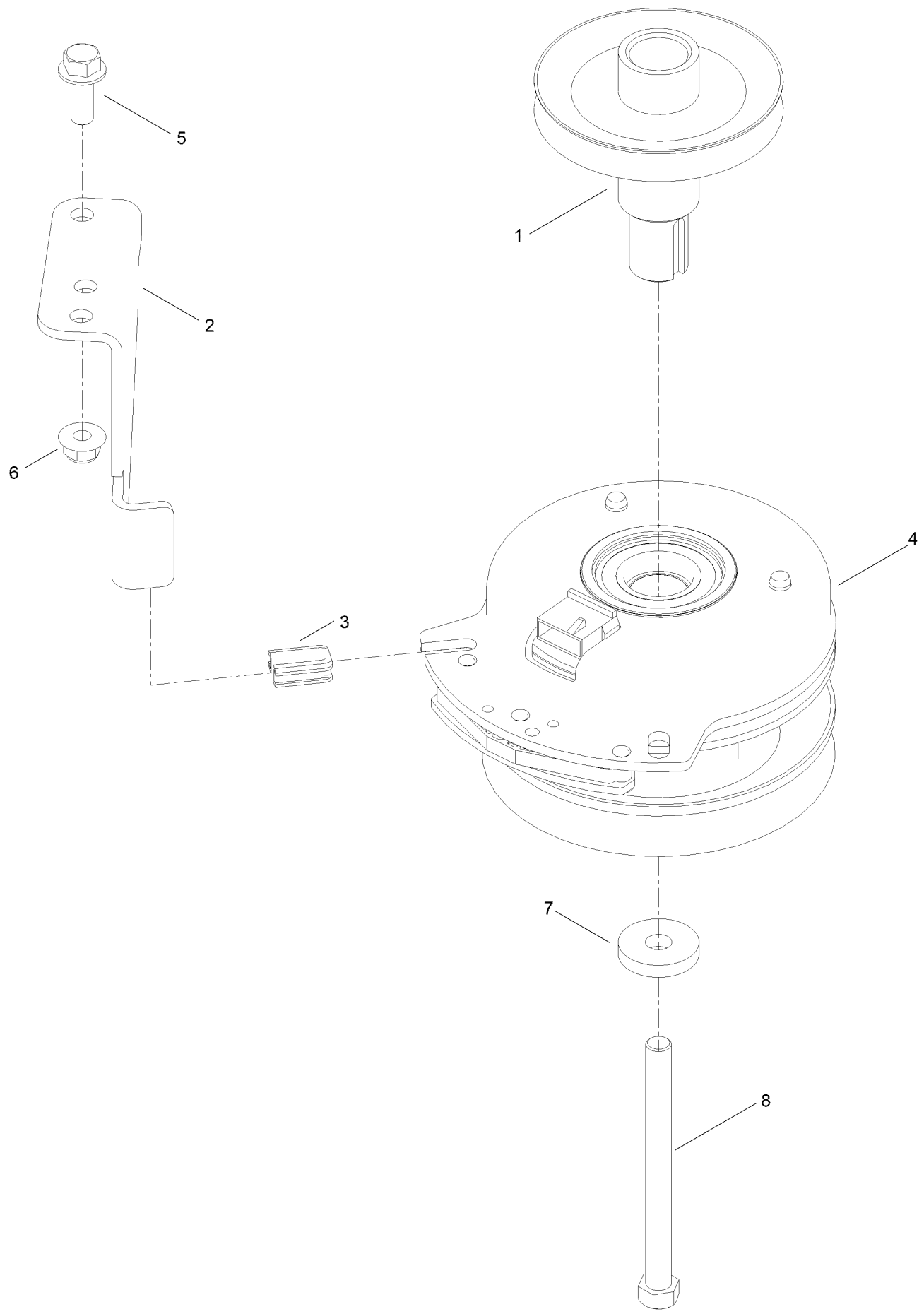

Clutch Assembly (continued)

<i>Ref.</i>	<i>Part Number</i>	<i>Qty.</i>	<i>Description</i>	<i>Ref.</i>	<i>Part Number</i>	<i>Qty.</i>	<i>Description</i>
1	138-9792	1	Pulley-Engine	5	3234-42	1	Screw-HHF
2	137-7000	1	Stop-Clutch (Wide)	6	104-8301	1	Nut-HF, NI
3	120-2217	1	Isolator-Clutch	7	112843	1	Washer
4	127-3410	1	Clutch-PTO	8	3212-19	1	Screw-HH

Attachments and Accessories

For 77501 TimeCutter 50in Riding Mower

Product Name	Model/Part
4-Cycle Fuel, Snow And Lawn 32oz Can	131-3823
Toro Premium Fuel Treatment 12oz Bottle	131-6572
Oil-30/10W-30 Synthetic (Quart).....	138-6053
50 Inch Recycler Kit.....	139-3240
50 Inch Bagging Enhancement Kit.....	139-7459
Led Light Kit.....	147-8757
Floormat Kit	147-8765
Kit-Caster Wheel	147-8772
Arm Rest Kit.....	147-8774
Kit-Striping, 50".....	147-8779
Kit, Hour Meter.....	147-8791
Kit, Jack TC	147-8835
Assist Bar Kit	161-4450
Transport Lock Kit.....	161-4510
10W30 4-Cycle Engine Oil (32oz Bottle).....	38280
Toro 4-Cycle SAE 30 Oil (32oz Bottle)	38903
Toro Deluxe Rider Cover.....	490-7319
Belt-Deck, 50 TCSS.....	79006
ROPS Kit	79487
Kit-Slope Sensor.....	79489
Residential Z Max 50in Bagger	79501

Notes:

Notes:

Notes:



Count on it.