



**Count on it.**

**Parts Catalog**

**Power Max<sup>®</sup> e26 60V  
Snowthrower**

Model No. 39926—Serial No. 416500000 and Up



# Ordering Replacement Parts

To order replacement parts, please supply the part number, the quantity, and the description of each part desired.

## Understanding Reference Numbers

Each identified part in an illustration has a reference number. The reference number for a part also appears in the parts list, along with other information about the part.

This catalog uses two special reference number formats, one to indicate parts in a service assembly and another to indicate the quantity of a given part in an illustration.

## Service Assembly Reference Numbers

Parts in service assemblies have reference numbers in the form a:b. The a represents the reference number of the entire service assembly and the b represents a sequential number unique to each part within the service assembly.

For example, a wheel assembly might be identified by reference number 6, the tire by 6:1, the valve by 6:2, and the wheel by 6:3. When you order the assembly identified by reference number 6, you receive all parts identified by reference numbers 6:1, 6:2, and 6:3. However, you may also order any part individually. Reference numbers of this type appear in illustration and in parts lists.

## Reference Numbers Indicating Quantity

In an illustration, if a reference number indicates more than one part, the reference number has the form nX y. The n represents the quantity of the part, the X is the multiplication symbol, and the y represents the reference number.

For example, in an illustration, the reference number 2X 37 means that two of the parts identified by reference number 37 are indicated.

# Contents

Main Frame and Auger Housing Assembly .....	4
Pulley and Bellcrank Assembly .....	6
Impeller Drive Assembly .....	8
Drive Assembly .....	10
Tire and Drive Assembly .....	12
Gearbox, Auger and Impeller Assembly .....	14
26 Inch Auger Gearcase Assembly No. 119-7641 .....	16
Impeller Assembly .....	18
Powerhead, Pulley and Belt Assembly .....	20
60 Volt Powerhead Assembly No. 139-5315 .....	22
Chute Assembly .....	24
Chute Control Assembly .....	26
Handle Assembly .....	28
Attachments and Accessories .....	30

# Main Frame and Auger Housing Assembly

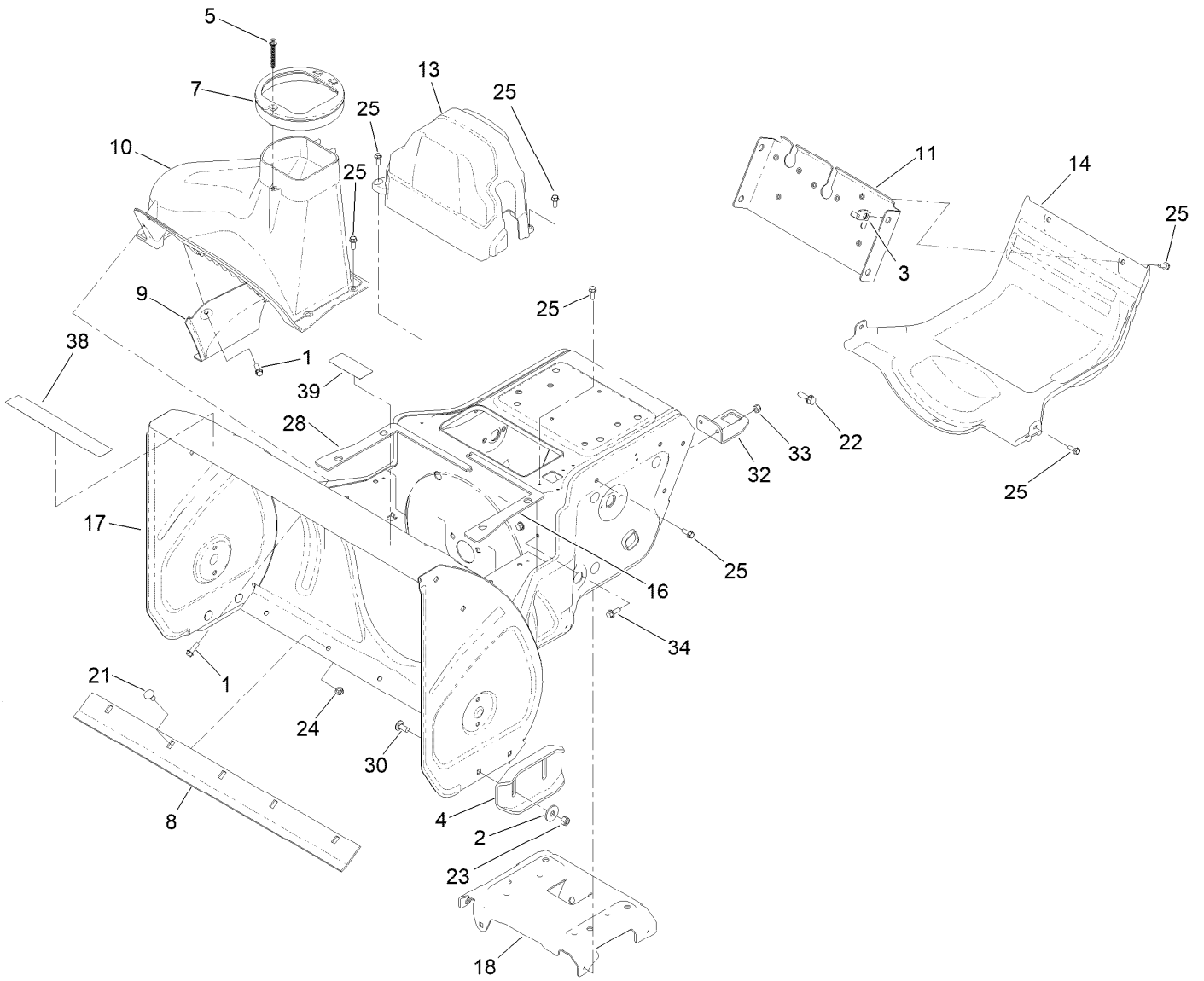

## Main Frame and Auger Housing Assembly (continued)

<i>Ref.</i>	<i>Part Number</i>	<i>Qty.</i>	<i>Description</i>	<i>Ref.</i>	<i>Part Number</i>	<i>Qty.</i>	<i>Description</i>
1	46-8091	6	Screw-HWH	18	139-5270	1	Brace-Frame
2	52-2861	4	Washer	21	3230-18	5	Screw-CARR
3	94-2413	4	Nut-U	22	3234-29	4	Screw-HHF
4	106-4588-01	2	Skid	23	3296-29	4	Nut-Lock, NI
5	114-3751	1	Screw-HWH, Plastite	24	3296-47	5	Nut-Lock,NI
7	138-3608	1	Guide-Chute	25	32144-85	17	Screw-HWH Thd Form
8	120-3872-01	1	Scraper-26 Inch	28	121-6841	1	Seal-Housing, RH
9	120-7158-01	1	Cover-Liner	30	3230-23	4	Bolt-CARR
10	120-7159	1	Cover	32	137-3410-03	1	Bracket-Post, Chute
11	120-7161-01	1	Brace-Frame	33	120-9678	2	Screw-HHF
13	120-7177	1	Cover-Belt	34	137-3094	2	Nut-Hex
14	120-7178	1	Cover-Lower	38	161-6032	1	Decal - Hardened Gears
16	120-7181	1	Seal-Housing, LH	39	161-6037	1	Decal - Compact 26
17	147-9471	1	Frame ASM				

# Pulley and Bellcrank Assembly

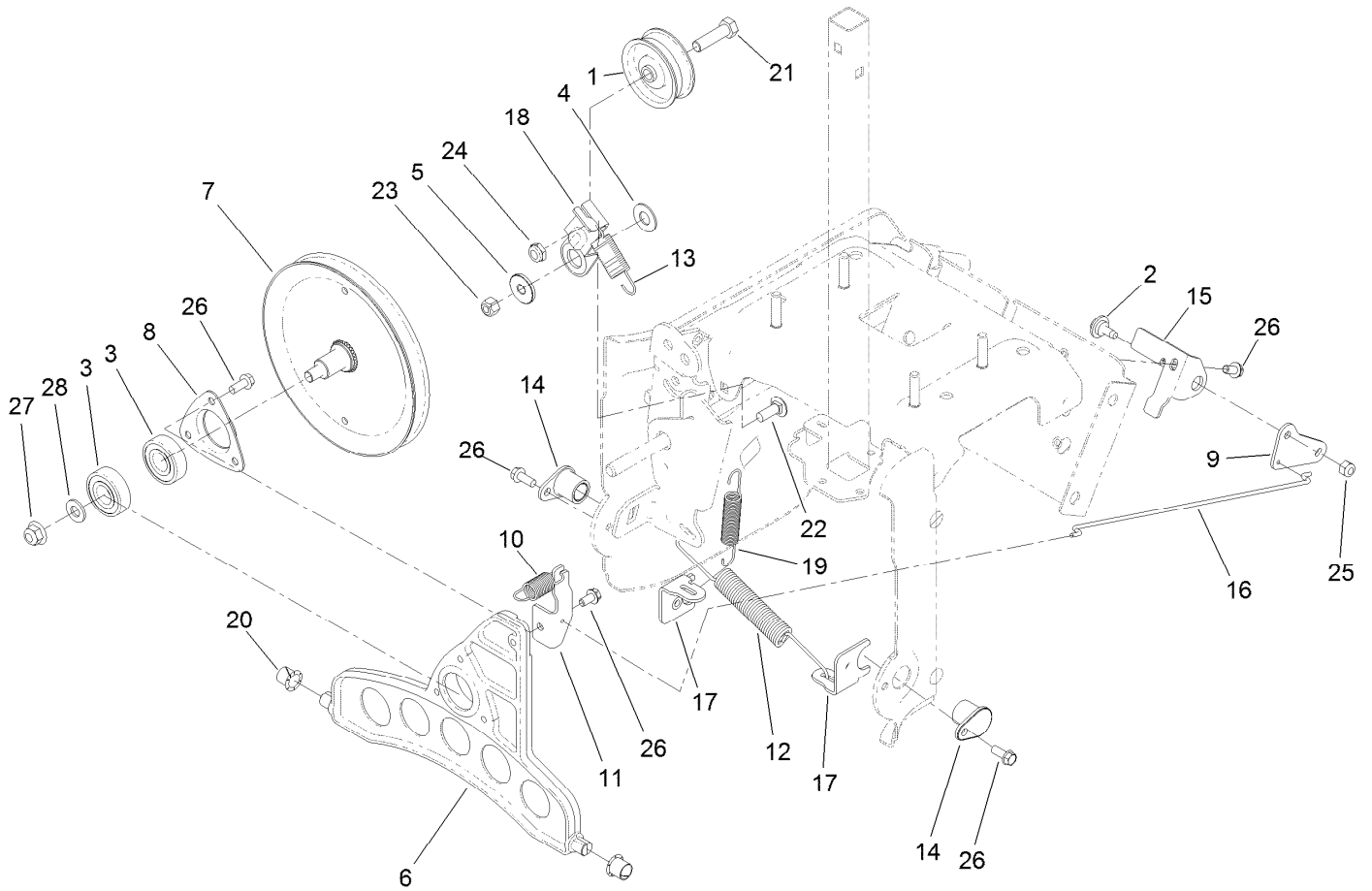

## Pulley and Bellcrank Assembly (continued)

<i>Ref.</i>	<i>Part Number</i>	<i>Qty.</i>	<i>Description</i>	<i>Ref.</i>	<i>Part Number</i>	<i>Qty.</i>	<i>Description</i>
1	3-4244	1	Pulley-Idler	15	120-7165-03	1	Bracket-Bellcrank
2	92-9698	1	Screw-Shoulder	16	136-7155	1	Link-Drive
3	38-7820	2	Bearing-Ball	17	120-9271	2	Bracket-Anchor, Spring
4	25-5640	1	Washer	18	136-7159	1	Arm-Idler, Traction
5	117-7711	1	Bushing-Idler	19	120-9275	1	Spring-Extension
6	119-7645	1	Plate-Wheel, Friction	20	256-257	2	Bushing-Nyliner
7	136-7152	1	Traction Pulley ASM	21	323-29	1	Screw-HH
8	136-7124	1	Retainer-Bearing	22	3230-10	1	Bolt-CARR
9	119-7670-03	1	Bellcrank-Drive	23	3296-29	1	Nut-Lock, NI
10	136-7153	1	Spring-Extension	24	3296-59	1	Nut-Lock, NI
11	119-7679	1	Bracket-Plate, Traction	25	3296-73	1	Nut-Lock, NI
12	120-3883	1	Spring-Extension	26	32144-85	7	Screw-HWH Thd Form
13	137-3435	1	Spring-Extension	27	104-8301	1	Nut-HF, NI
14	120-7156	2	Bushing-Plate, Traction	28	3256-24	1	Washer-Plain

# Impeller Drive Assembly

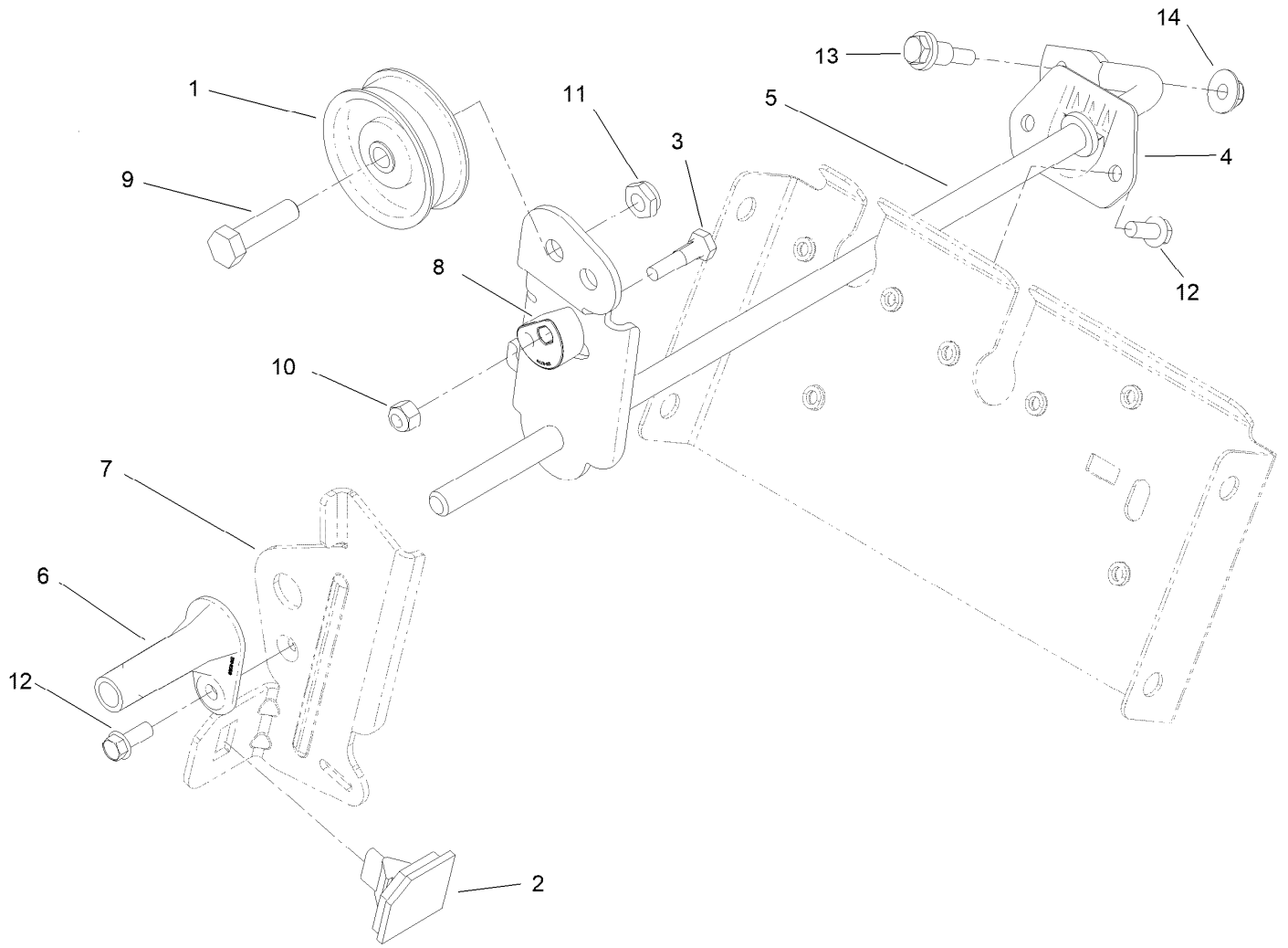



## Impeller Drive Assembly (continued)

<i>Ref.</i>	<i>Part Number</i>	<i>Qty.</i>	<i>Description</i>	<i>Ref.</i>	<i>Part Number</i>	<i>Qty.</i>	<i>Description</i>
1	3-4244	1	Pulley-Idler	8	120-9276	1	Eccentric-Brake, Impeller
2	66-8060	1	Pad-Brake	9	323-29	1	Screw-HH
3	136-8674	1	Bolt-Pivot, Eccentric	10	3296-42	1	Nut-Lock, NI
4	120-7167	1	Bushing-Rod, Clutch	11	3296-59	1	Nut-Lock, NI
5	120-9254-03	1	Impeller Clutch ASM	12	32144-85	3	Screw-HWH Thd Form
6	120-9256	1	Pivot-Brake, Impeller	13	104-0858	1	Bolt-Shoulder
7	120-9257-03	1	Arm-Brake, Impeller	14	137-3016	1	Nut-HF

# Drive Assembly

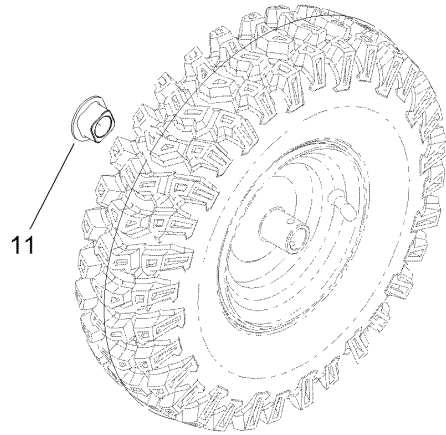
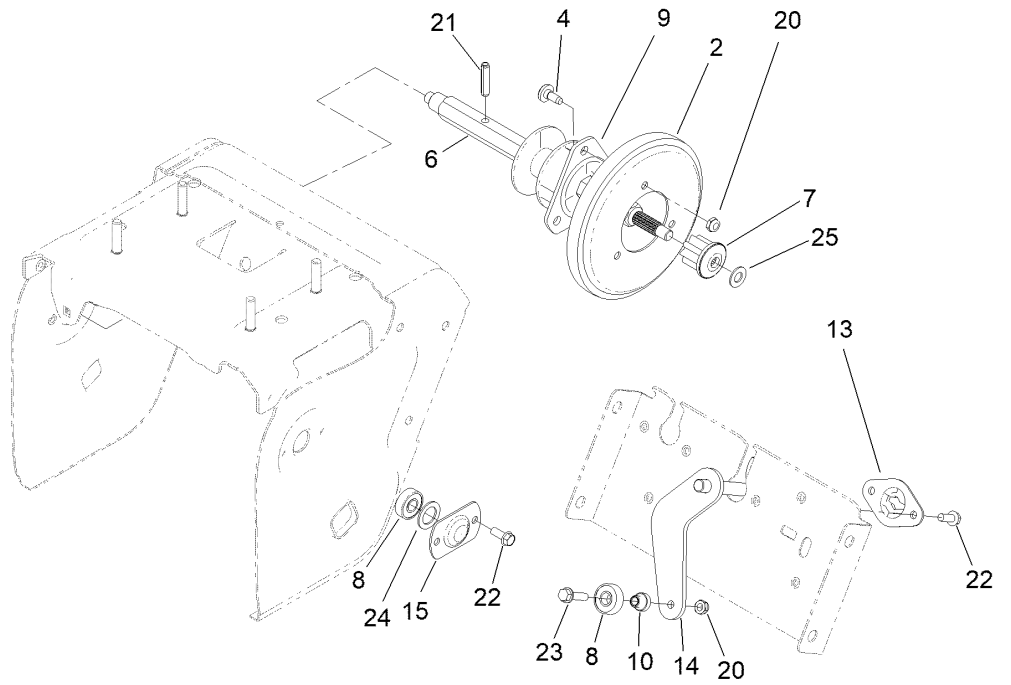
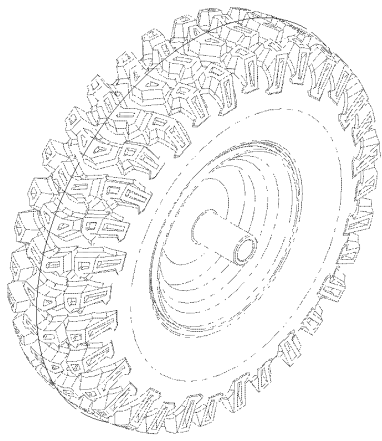

## Drive Assembly (continued)

<i>Ref.</i>	<i>Part Number</i>	<i>Qty.</i>	<i>Description</i>	<i>Ref.</i>	<i>Part Number</i>	<i>Qty.</i>	<i>Description</i>
2	119-1567	1	Wheel-Friction	14	120-7193-03	1	Shift Plate ASM
4	120-7950	3	Screw-Torx	15	136-7158	2	Retainer-Bearing
6	140-3745	1	Shaft-Hex	20	3296-56	4	Nut-Lock, NI
7	119-7616	1	Gear-Pinion, 8 Tooth	21	32121-9	1	Pin-Roll, Slotted
8	121-6835	3	Bearing-Ball	22	32144-85	6	Screw-HWH Thd Form
9	119-7630	1	Trunnion	23	32144-86	1	Screw-HWHTF
10	119-7684	1	Spacer-Plate, Shift	24	121-6840	2	Washer-Rubber
11	120-7162	2	Bushing-Axle	25	145-0743	1	Washer-Flat
13	120-7191	1	Retainer-Plate, Shift				

# Tire and Drive Assembly

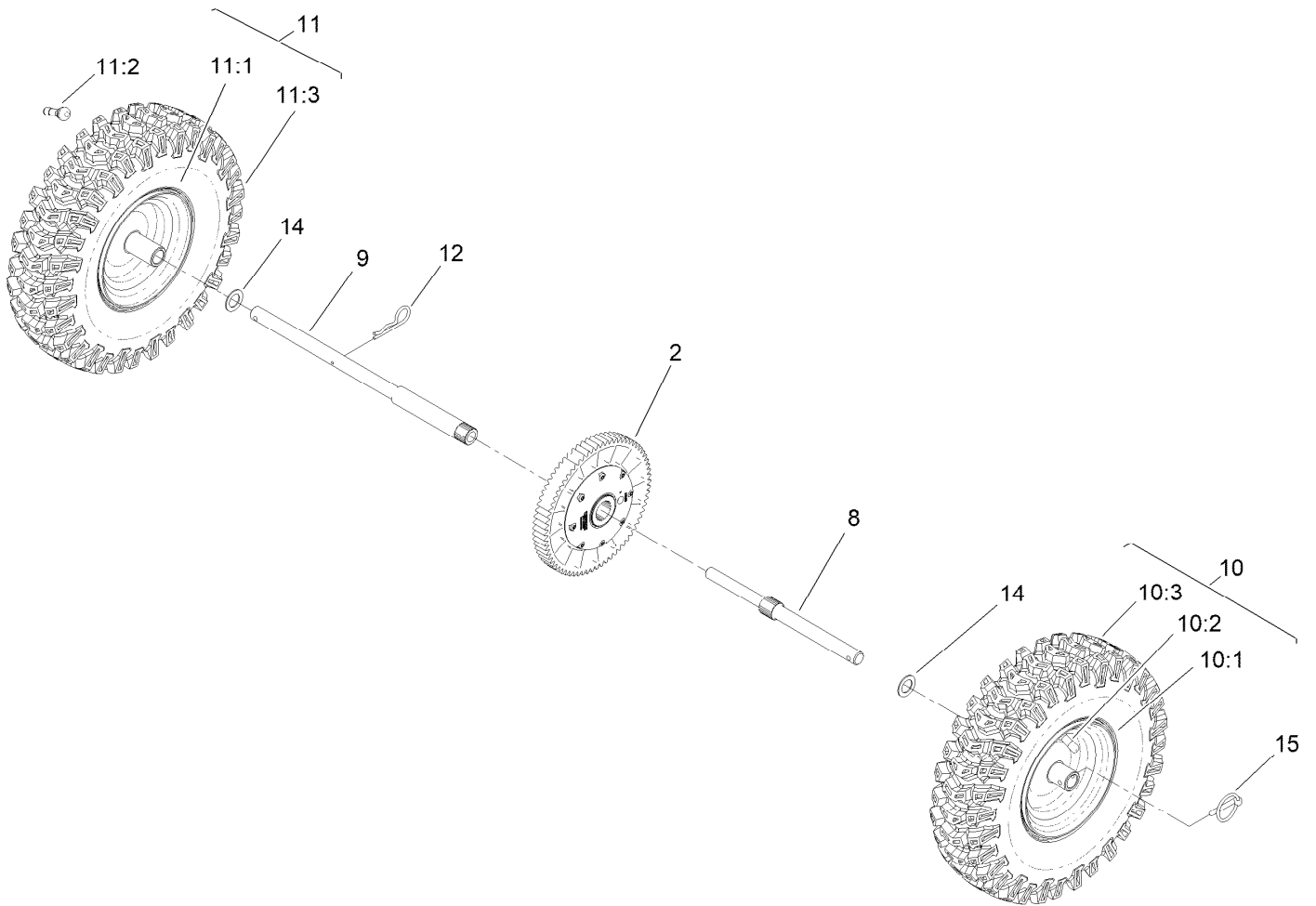

## Tire and Drive Assembly (continued)

<i>Ref.</i>	<i>Part Number</i>	<i>Qty.</i>	<i>Description</i>	<i>Ref.</i>	<i>Part Number</i>	<i>Qty.</i>	<i>Description</i>
2	140-3747	1	Transmission-Gt, Di200	11	138-3659	1	RH Wheel And Tire ASM
8	140-3746	1	Axle-Lt, Cts	11:1	138-3669	1	Wheel (15X4 Tire)
9	140-3742	1	Axle-Rt, Cts	11:2	232-27	1	Stem-Valve
10	138-3660	1	LH Wheel And Tire ASM	11:3	138-3668	1	Tire
10:1	138-3669	1	Wheel (15X4 Tire)	12	3290-343	1	Pin-Hair
10:2	232-27	1	Stem-Valve	14	3-8664	2	Washer-Thrust
10:3	138-3668	1	Tire	15	107-3039	2	Pin-Lynch

# Gearbox, Auger and Impeller Assembly

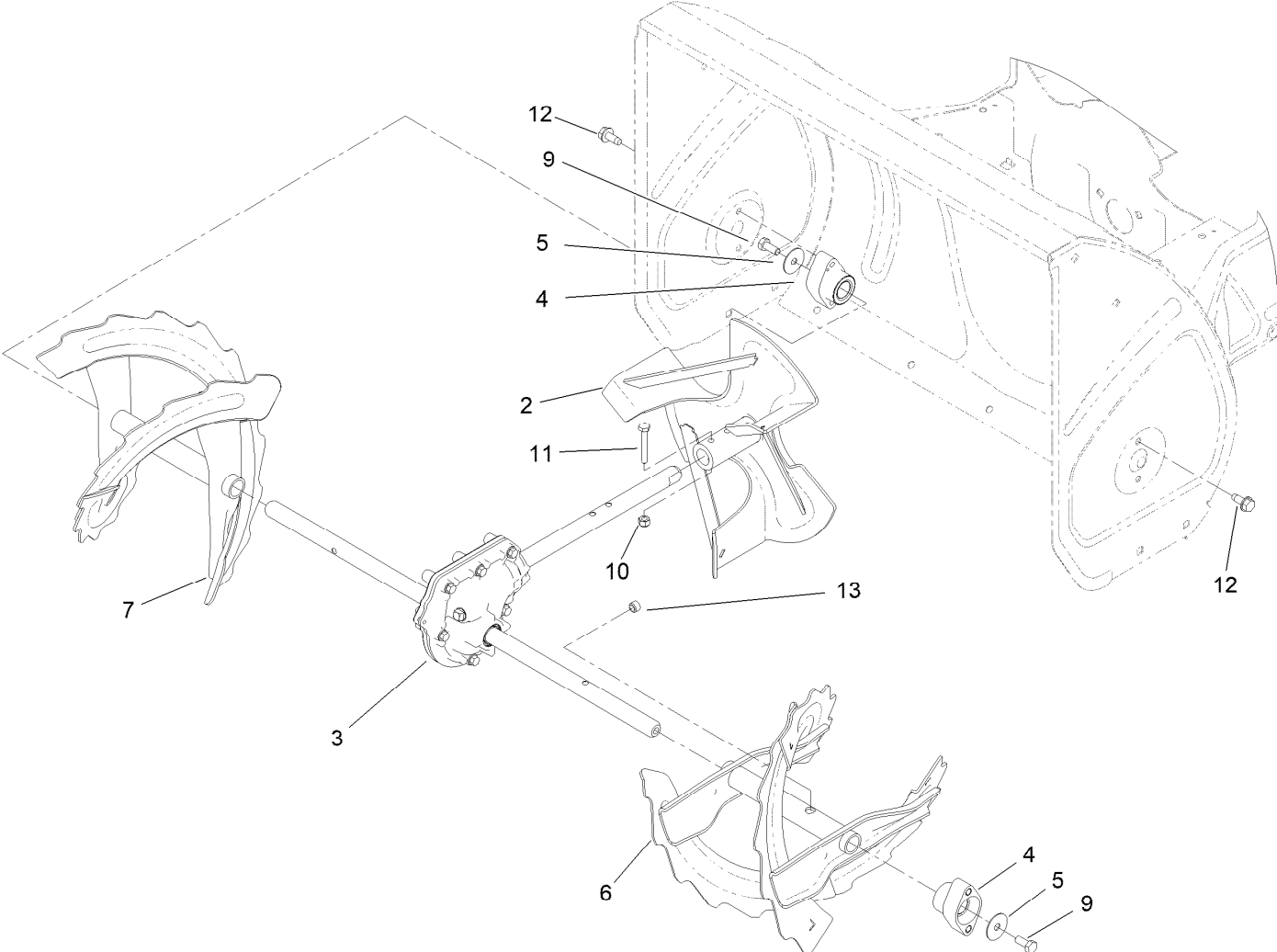

## Gearbox, Auger and Impeller Assembly (continued)

<i>Ref.</i>	<i>Part Number</i>	<i>Qty.</i>	<i>Description</i>	<i>Ref.</i>	<i>Part Number</i>	<i>Qty.</i>	<i>Description</i>
2	119-7612-03	1	Impeller ASM	9	322-3	2	Screw-HH
3	119-7641	1	Gearcase ASM	10	3296-42	4	Nut-Lock, NI
4	120-3860	2	Bearing-Augur	11	321-10	4	Screw-HH
5	120-3862	2	Washer-Thrust	12	32144-70	4	Screw-HWHTF
6	161-3927-03	1	Auger ASM, LH (Weldment)	13	55-9370	2	Spacer-Blade, Rotor
7	161-3926-03	1	Auger ASM, RH (Weldment)				

# 26 Inch Auger Gearcase Assembly No. 119-7641

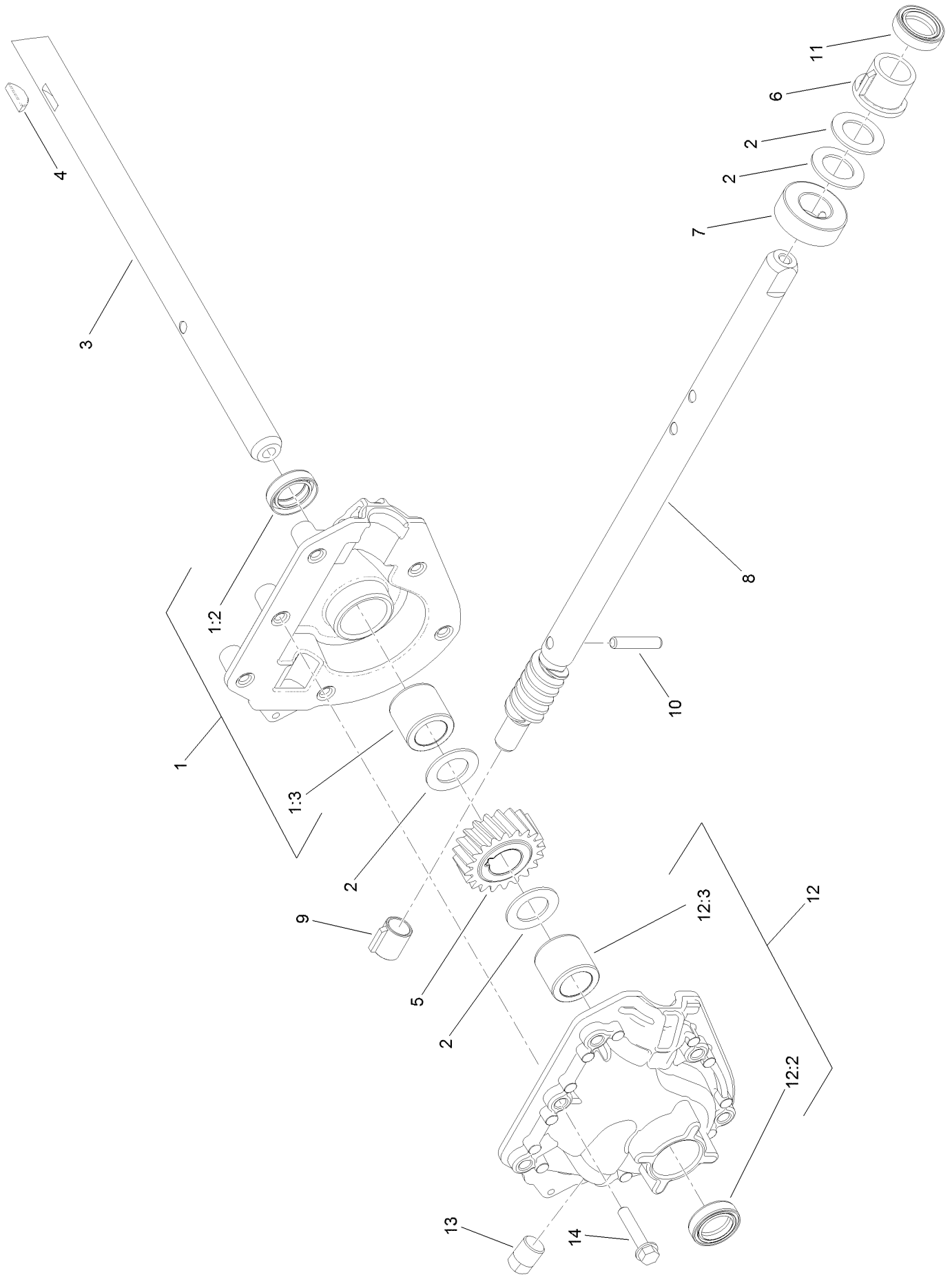



## 26 Inch Auger Gearcase Assembly No. 119-7641 (continued)

<i>Ref.</i>	<i>Part Number</i>	<i>Qty.</i>	<i>Description</i>	<i>Ref.</i>	<i>Part Number</i>	<i>Qty.</i>	<i>Description</i>
1	121-1209	1	RH Auger Gearcase ASM	8	121-1234	1	Shaft-Impeller, Rolled
1:2	121-6634	1	Seal-Shaft	9	62-1150	1	Bushing-Worm
1:3	120-9269	1	Bushing-Sleeve	10	107-8899	1	Pin-Dowel
2	119-7640	4	Washer-Thrust	11	121-6634	1	Seal-Shaft
3	119-7639	1	Shaft-Output, Auger	12	121-1210	1	LH Auger Gearcase ASM
4	3257-5	1	Key-Woodruff	12:2	121-6634	1	Seal-Shaft
5	119-1576	1	Gear-Helical, 20 Tooth	12:3	120-9269	1	Bushing-Sleeve
6	119-7635	1	Bushing-Input	13	121-6832	1	Plug-Pipe, SQH
7	119-7636	1	Collar-Thrust	14	108-4862	6	Screw-HWH Thd Roll

# Impeller Assembly

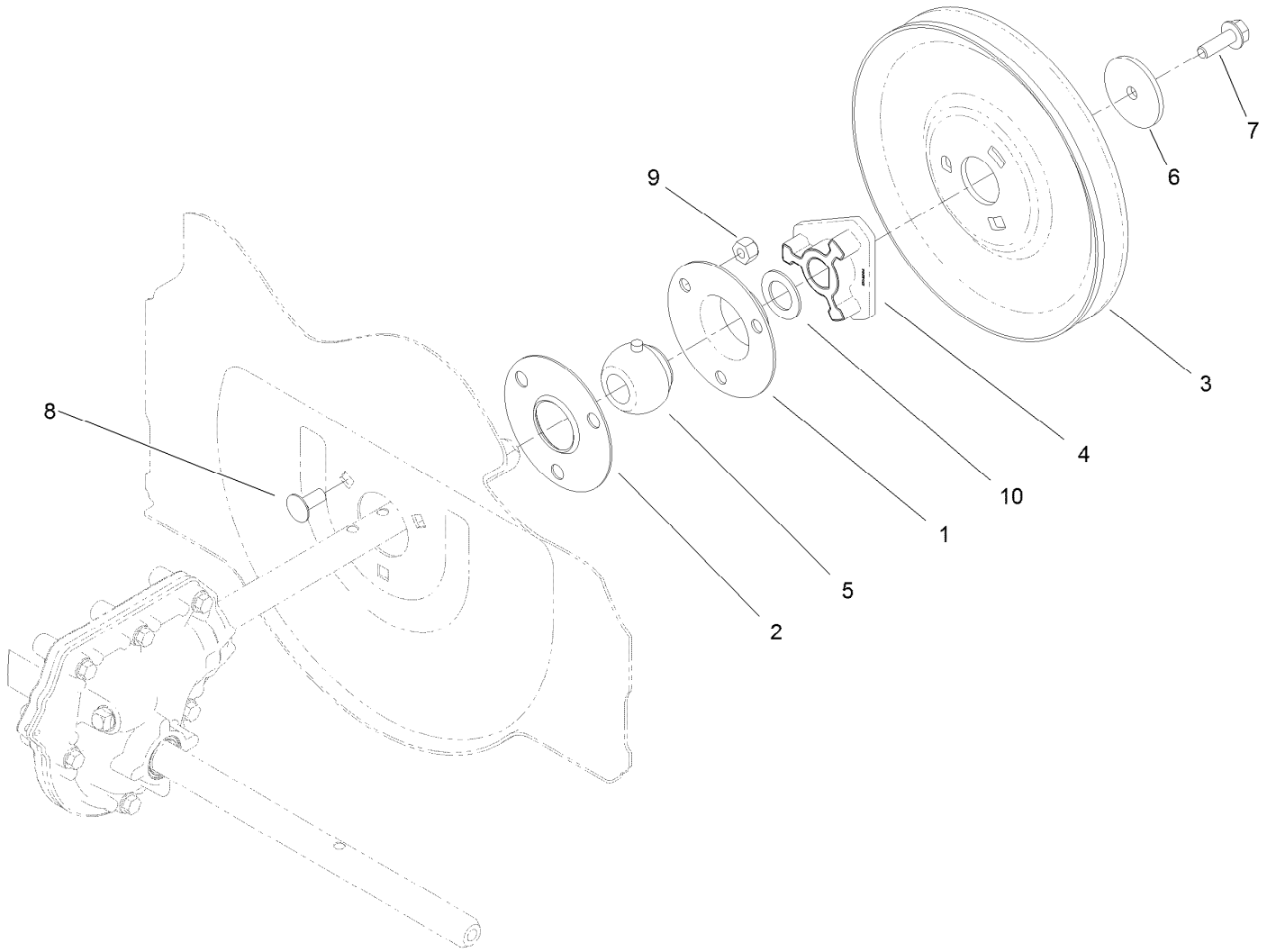

## Impeller Assembly (continued)

<i>Ref.</i>	<i>Part Number</i>	<i>Qty.</i>	<i>Description</i>	<i>Ref.</i>	<i>Part Number</i>	<i>Qty.</i>	<i>Description</i>
1	26-6110	1	Flange-Cup, Bearing	6	121-1230	1	Washer-Plain
2	26-6120	1	Flange-Cup, Bearing	7	115-5142	1	Screw-HHF
3	136-7157	1	Pulley-Impeller	8	3230-23	3	Bolt-CARR
4	120-9264	1	Hub-Impeller, Pulley	9	3296-29	3	Nut-Lock, NI
5	120-9272	1	Bearing	10	119-7640	1	Washer-Thrust

# Powerhead, Pulley and Belt Assembly

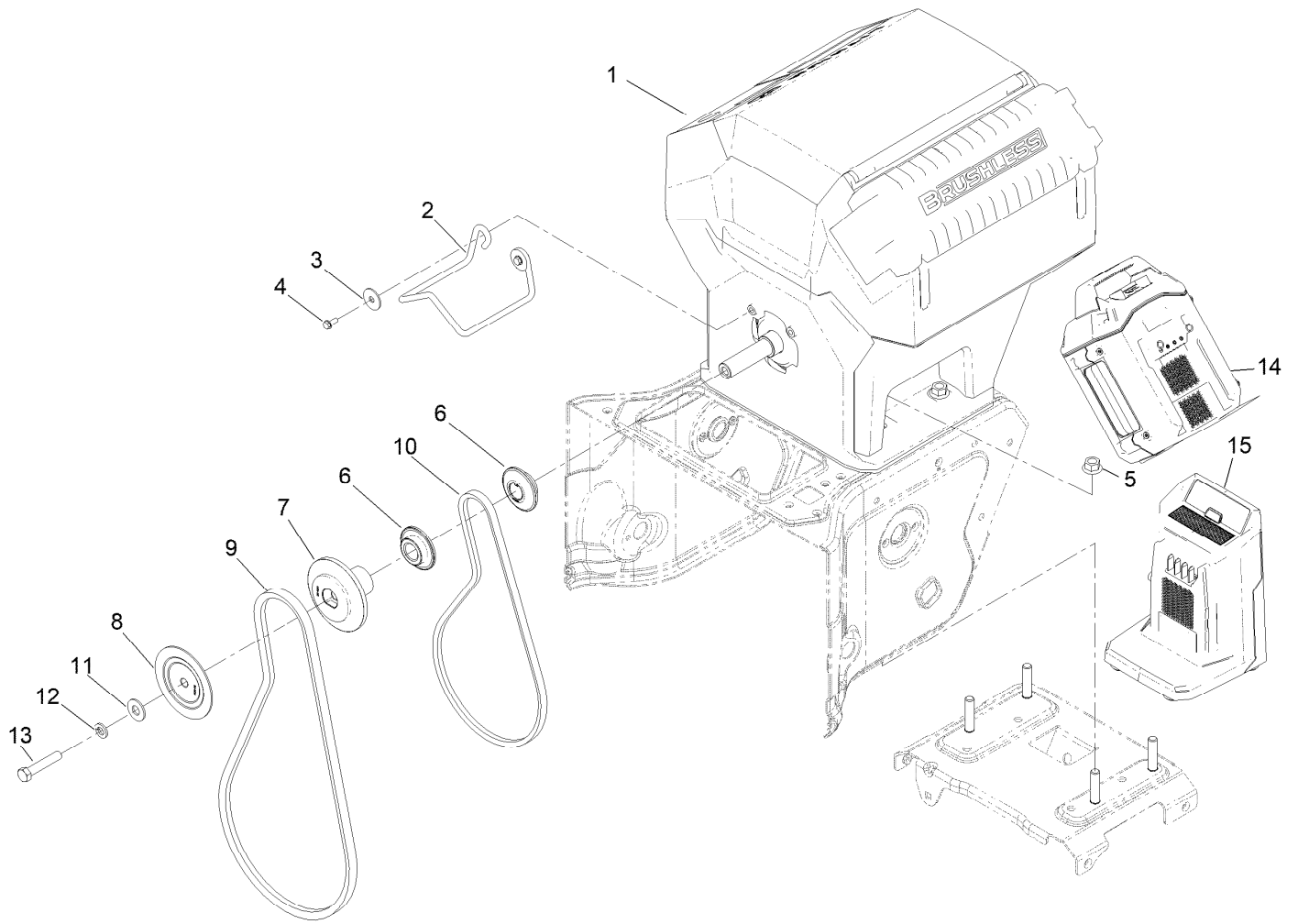

## Powerhead, Pulley and Belt Assembly (continued)

<i>Ref.</i>	<i>Part Number</i>	<i>Qty.</i>	<i>Description</i>	<i>Ref.</i>	<i>Part Number</i>	<i>Qty.</i>	<i>Description</i>
1	139-5315	1	Powerhead-60V	9	147-9462	1	Belt-V
2	139-5299	1	Guide-Belt	10	120-3893	1	Belt-V
3	114-9049	2	Washer-Flat,Fender	11	3256-4	1	Washer-Flat
4	139-1700	2	Screw-HWH, Thd Roll	12	3253-21	1	Washer-Lock
5	136-8683	4	Nut-Lock	13	120-2302	1	Screw-HH
6	137-3400	2	Pulley-Engine, Traction	14	88675	2	Battery-Li-Ion, 60V 7.5Ah, 405Wh,Dom
7	120-9283	1	Pulley-Auger, Rear	15	88602	2	Charger-Battery, 60V 2 Amp
8	120-9284	1	Pulley-Auger, Front				

# 60 Volt Powerhead Assembly No. 139-5315

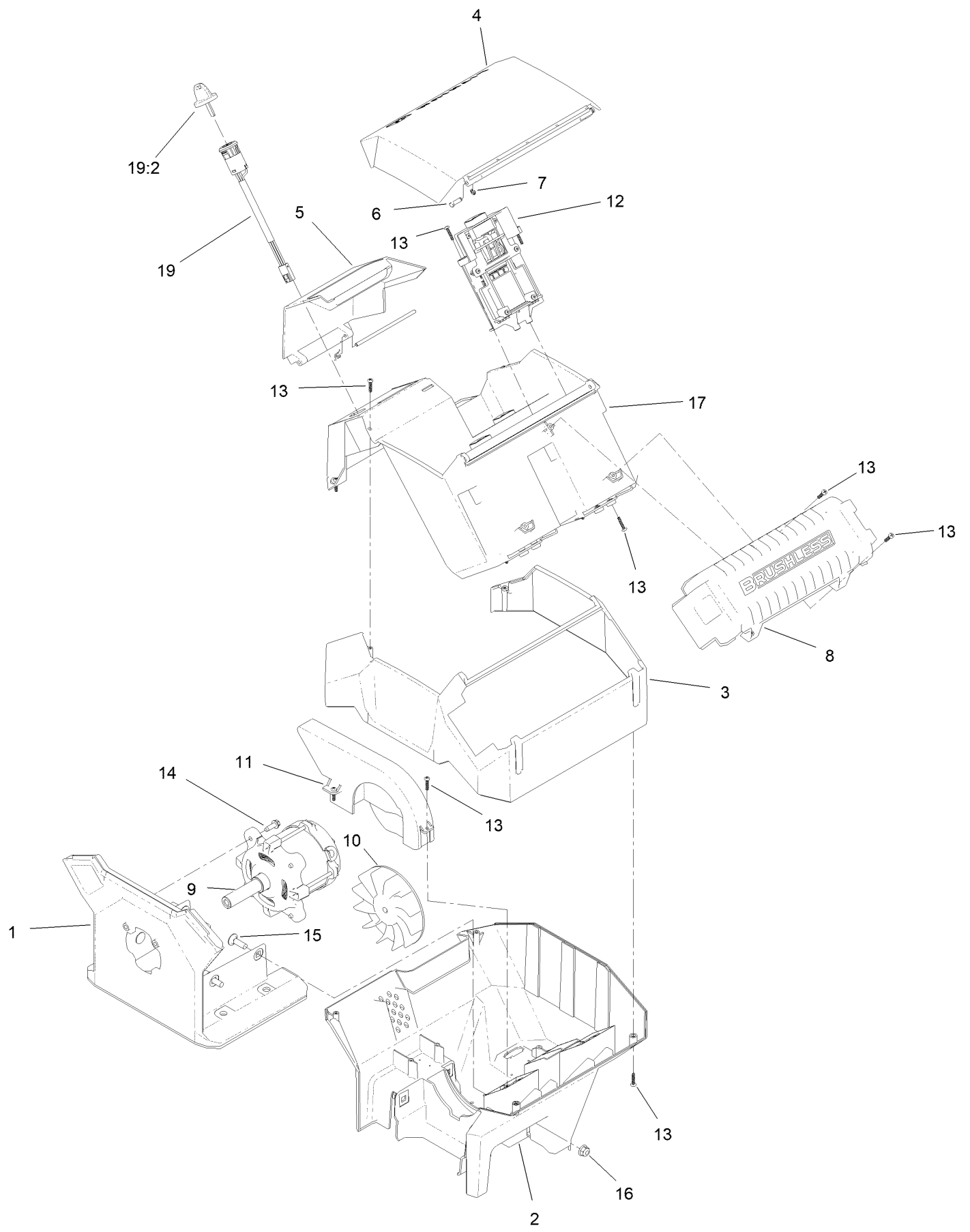

## 60 Volt Powerhead Assembly No. 139-5315 (continued)

<i>Ref.</i>	<i>Part Number</i>	<i>Qty.</i>	<i>Description</i>	<i>Ref.</i>	<i>Part Number</i>	<i>Qty.</i>	<i>Description</i>
1	139-5316	1	Motor Mount	11	139-5269	1	Cover-Fan
2	139-5317	1	Housing-Motor	12	137-9435	3	Battery Track Assembly
3	139-5318	1	Cover-Controller	13	94-4496	27	Screw-PPH
4	139-5320	1	Door-Top	14	49-2040	4	Screw-HWHTF
5	139-5321	1	Door-Bottom	15	3230-2	4	Bolt-CARR
6	144-4121	2	Pin-Battery Cover	16	104-8300	4	Nut-HF, NI
7	110-1758	2	Ring-Retaining	17	139-5319	1	Bucket-Battery
8	147-9461	1	Motor Controller ASM-Powerhead	19	161-5981	1	Ignition ASM-Powerhead
9	139-5289	1	Motor-60V, 2 Stage	19:2	147-1755	1	Key-60V 2 Stage Power Head
10	139-5322	1	Fan-Fc				

# Chute Assembly

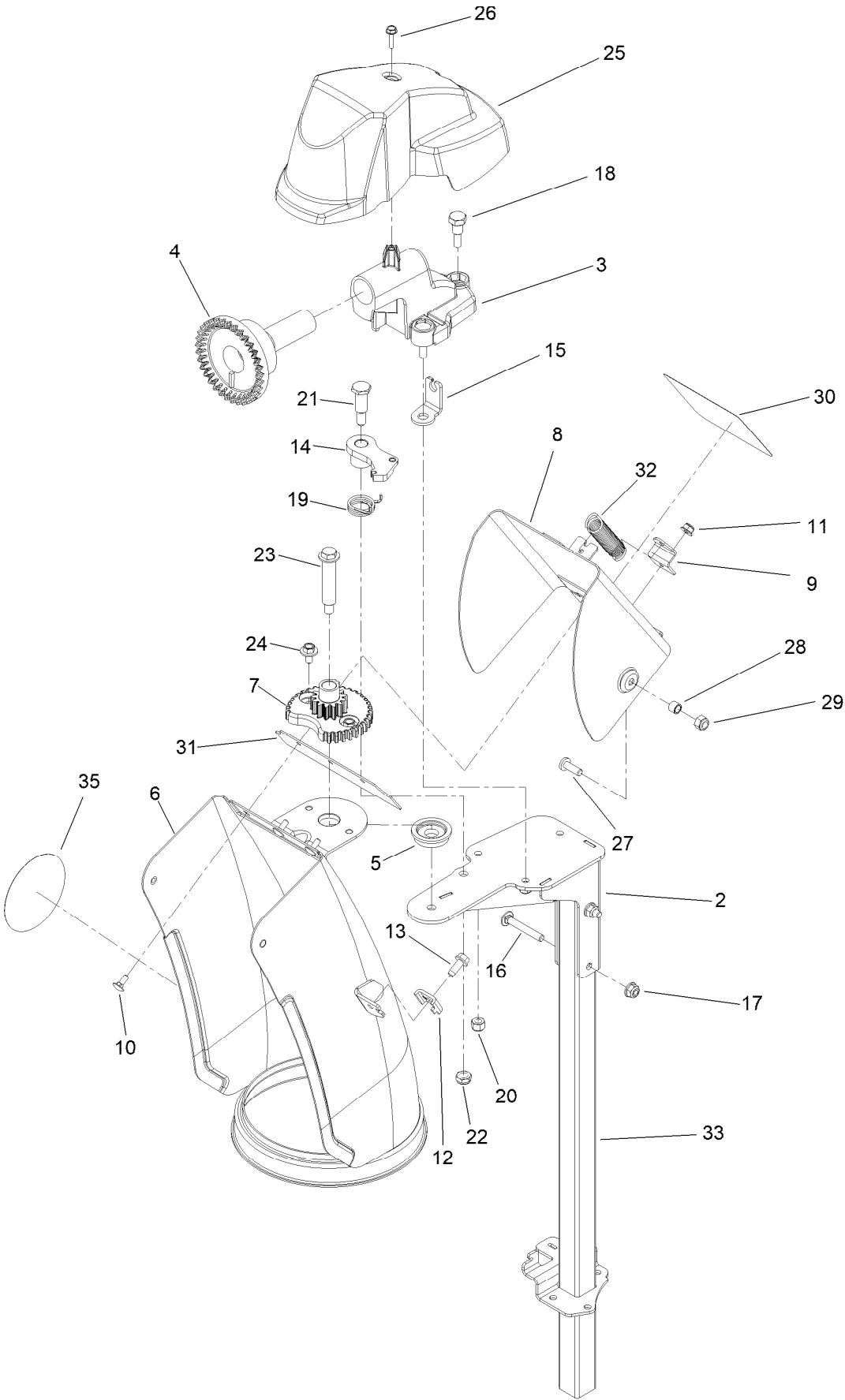



## Chute Assembly (continued)

<i>Ref.</i>	<i>Part Number</i>	<i>Qty.</i>	<i>Description</i>	<i>Ref.</i>	<i>Part Number</i>	<i>Qty.</i>	<i>Description</i>
2	144-1640-03	1	Support-Chute Weld ASM, Upper	18	136-7197	3	Screw-Shoulder
3	138-3606	1	Mount-Gear, Face	19	108-7315	1	Spring-Torsion
4	106-4471	1	Gear-Face	20	137-3088	3	Nut-Hex
5	106-4422	1	Spacer-Chute	21	137-3103	1	Screw-Shoulder, HH
6	138-3611-01	1	Chute	22	137-3089	3	Nut-Hex
7	106-4472	1	Gear-Chute	23	136-7199	1	Bolt-Shoulder
8	138-3615-01	1	Deflector	24	32144-4	2	Screw-HWH
9	138-3612-01	1	Bracket-Spring	25	138-3627	1	Cover-Chute, Gear
10	135-1929	3	Bolt-CARR	26	98-1375	1	Screw-HWH
11	138-0719	3	Nut-HF	27	138-0689	1	Screw-PH
12	136-7191	1	Clamp-Cable	28	138-3678	1	Spacer
13	137-3043	1	Screw-HWH	29	137-3094	1	Nut-Hex
14	106-4476	1	Latch-Chute	30	137-6198	1	Decal-Danger
15	138-3607	1	Anchor-Cable	31	138-3671	1	Gasket-Deflector
16	120-9698	2	Bolt-CARR	32	138-8493	1	Spring-Chute, Upper
17	119-4040	2	Nut-HF, NI	33	144-1642-03	1	Chute Support ASM [black]
				35	161-6031	1	Decal - Anti-Clog

# Chute Control Assembly

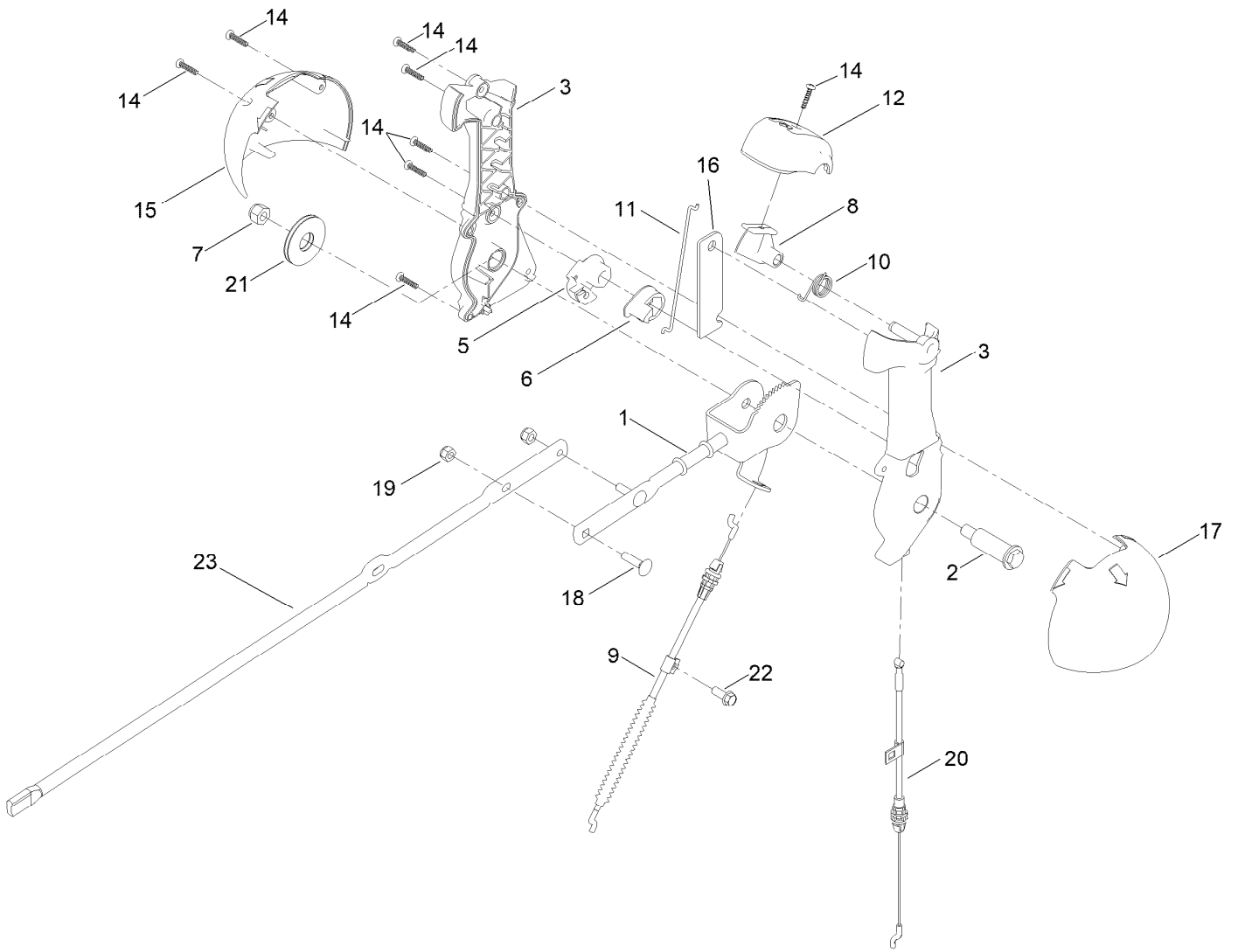

## Chute Control Assembly (continued)

<i>Ref.</i>	<i>Part Number</i>	<i>Qty.</i>	<i>Description</i>	<i>Ref.</i>	<i>Part Number</i>	<i>Qty.</i>	<i>Description</i>
1	138-0662	1	Rod-Control, Chute	14	94-4496	8	Screw-PPH
2	138-0659	1	Screw-Shoulder, HWH	15	136-6677	1	Globe-Quickstick, RH
3	139-1552	1	Chute Control Lever ASM	16	136-6632	1	Plate-Stiffner
5	105-9988	1	Lever-Cable, Deflector	17	136-6678	1	Globe-Quickstick, LH
6	106-7310	1	Pawl-Latch	18	137-3056	3	Bolt-CARR
7	137-3087	1	Nut-Hex	19	137-3094	3	Nut-Hex
8	137-6238	1	Trigger-Latch	20	144-1237	1	Cable-Rotation, Chute
9	138-3672	1	Cable-Control, Deflector	21	138-0744	1	Washer-Friction, Composite
10	105-9982	1	Spring-Torsion	22	32144-85	1	Screw-HWH Thd Form
11	138-0688	1	Link-Latch	23	144-1236	1	Rod-Chute
12	137-6239	1	Cap-Lever				

# Handle Assembly

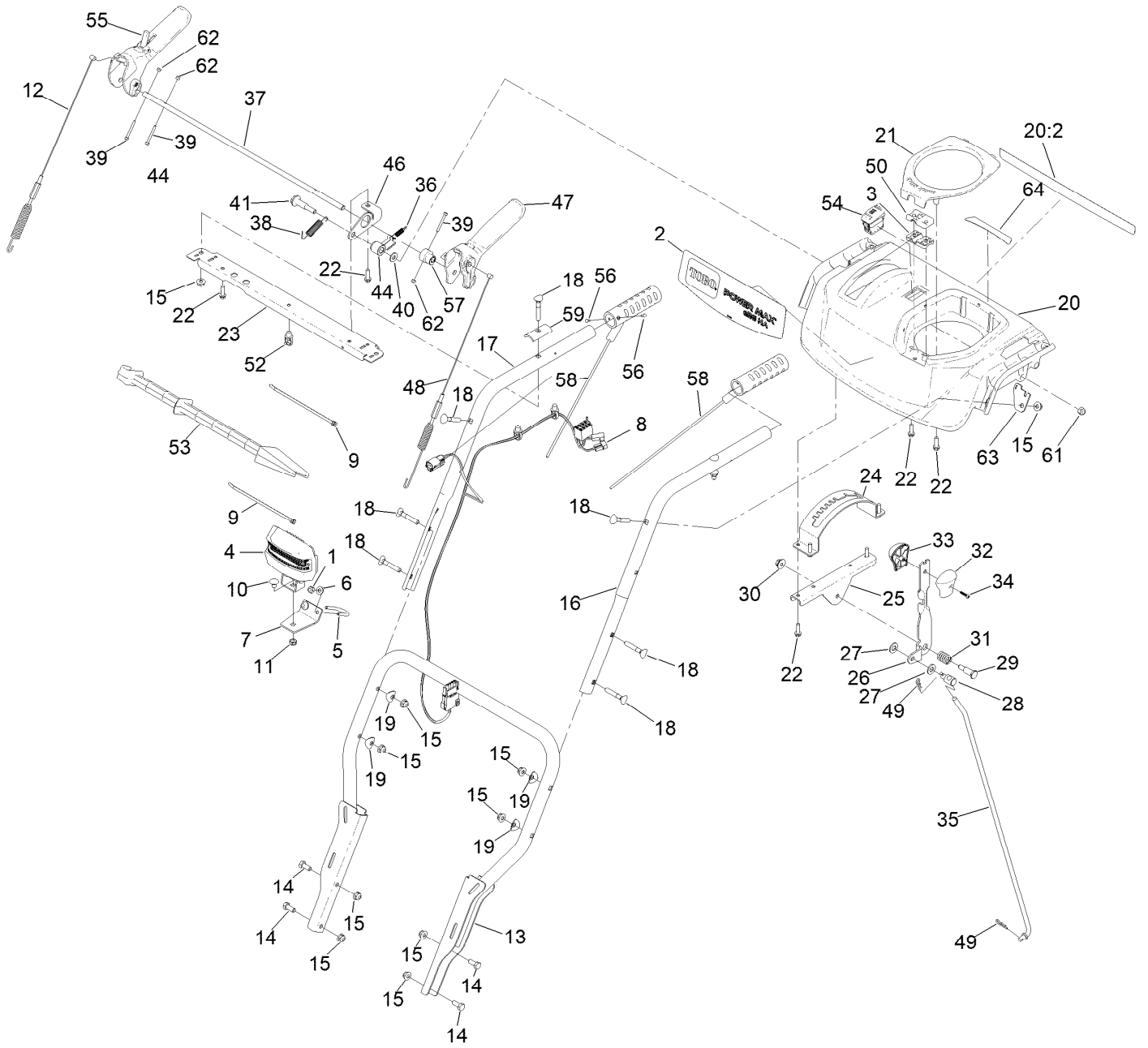

## Handle Assembly (continued)

<i>Ref.</i>	<i>Part Number</i>	<i>Qty.</i>	<i>Description</i>	<i>Ref.</i>	<i>Part Number</i>	<i>Qty.</i>	<i>Description</i>
1	137-3094	2	Nut-Hex	30	137-3038	1	Nut-HF
2	145-0852	1	Decal - Consol	31	136-7121	1	Spring-Compression
3	139-3587	1	Support-Rod, Lower	32	105-9999	1	Knob-Shift, LH
4	138-0670	1	LED Light ASM	33	106-4423	1	Knob-Shift, RH
5	136-7120	1	Clamp-Light	34	94-4496	1	Screw-PPH
6	139-1699	2	Washer-Flat	35	145-0696	1	Rod-Shift
7	127-5961-03	1	Bracket-Light	36	136-7161	1	Spring-Lockout, Handle
8	145-0899	1	Harness-Wire, LED And Hand Warmers	37	144-1343	1	Rod-Lockout
9	614249	3	Tie-Cable	38	136-7162	1	Spring-Return, Lever
10	3230-19	1	Bolt-CARR	39	145-0660	3	Screw-HSH,Spl
11	137-3089	1	Nut-Hex	40	98-3499	1	Washer-Flat
12	161-0972	1	Cable-Auger	41	145-0687	1	Screw-Shoulder
13	147-7549-03	1	Handle-Lower	44	144-1342	1	Latch, Lockout
14	137-3052	4	Screw-HH	46	145-0677-03	1	Bracket-Interlock
15	138-8401	12	Nut-HF	47	144-1347	1	Lever-Control
16	137-6206-03	1	Handle-Upper, LH	48	161-0988	1	Cable-Traction
17	137-6207-03	1	Handle-Upper, RH	49	137-3083	2	Pin-Hair
18	137-3107	8	Screw-Handle	50	139-3588	1	Support-Rod, Upper
19	137-3009	4	Washer-Cup	52	32180-030	1	Clip-Tie
20	145-0665	1	Control Panel Assembly	53	110-3408	1	Stick-Cleanout
20:2	137-6249	1	Decal-Safety	54	122-1124	1	Switch-Rocker, On-None-Off (Heater)
21	137-6178	1	Cover-Quickstick	55	145-0871	1	Auger Control ASM
22	137-3099	8	Screw-Plastite, HWH	56	3290-271	4	Rivet-Pop
23	145-4075-01	1	Brace-Console	57	144-1341	1	Cam-Lockout
24	137-6187-03	1	Gate-Shift	58	144-1604	2	Grip-Heated
25	137-6188-03	1	Bracket-Shift	59	147-7548	1	Saddle-Handle
26	144-2827-03	1	Selector-Speed	61	137-3093	1	Nut-Hex
27	115-1166	2	Washer-Plain	62	140-3749	3	Nut-Lock Rohs
28	136-7193	1	Trunnion-Rod	63	144-1345	1	Plate-Spring
29	137-3103	1	Screw-Shoulder, HH	64	161-6030	1	Decal - Quick Stick

# Attachments and Accessories

## For 39926 Power Max e26 60V Snowthrower

<b>Product Name</b>	<b>Model/Part</b>
Weight Kit .....	107-3815
Snow Cab Kit.....	127-5960
Non-Marking Skid Kit.....	38211
Heavy-Duty Skid Kit.....	38212
Drift Breaker Kit .....	38213
Toro 2-Stage Cover.....	490-7466
Plain 2-Stage Cover.....	490-7467
60V LI-ION Battery 10.0 AH .....	66810
60V Battery Charger 2 AMP .....	88602
60V Rapid Battery Charger 5.4 AMP .....	88605
60V LI-ION Battery 6.0 AH.....	88660
60V LI-ION Battery 7.5 AH.....	88675

**Notes:**



**Count on it.**